

FCC PART 15.407

TEST REPORT

For

Huawei Technologies Co., Ltd

Administration Building, Headquarters of Huawei Technologies Co.,Ltd., Bantian,Longgang District, Shenzhen, 518129, P.R.C

FCC ID: QISAP2030DN

Report Type: Original Report	Product Type: Wireless LAN Access Point
Test Engineer: Edison Hu	<i>Edison.hu</i>
Report Number: RKS161113002-00E	
Report Date: 2016-11-20	
Reviewed By: EMC Engineer	<i>Jesse.Huang</i>
Test Laboratory:	Bay Area Compliance Laboratories Corp. (Kunshan) No.248 Chenghu Road,Kunshan, Jiangsu province,China Tel: +86-0512-86175000 Fax: +86-0512-88934268 www.baclcorp.com.cn

Note: This test report is prepared for the customer shown above and for the device described herein. It may not be duplicated or used in part without prior written consent from Bay Area Compliance Laboratories Corp. (Kunshan). This report is valid only with a valid digital signature. The digital signature may be available only under the Adobe software above version 7.0.

TABLE OF CONTENTS

GENERAL INFORMATION.....	4
PRODUCT DESCRIPTION FOR EQUIPMENT UNDER TEST (EUT)	4
ANTENNA INFORMATION	4
OBJECTIVE	4
RELATED SUBMITTAL(S)/GRANT(S)	4
TEST METHODOLOGY	5
TEST FACILITY	5
SYSTEM TEST CONFIGURATION.....	6
DESCRIPTION OF TEST CONFIGURATION	6
EUT EXERCISE SOFTWARE	6
EQUIPMENT MODIFICATIONS	10
SUPPORT EQUIPMENT LIST AND DETAILS	10
EXTERNAL I/O CABLE	10
BLOCK DIAGRAM OF TEST SETUP	11
SUMMARY OF TEST RESULTS	12
FCC §15.407(f) & §1.1310 & §2.1091- MAXIMUM PERMISSIBLE.....	13
EXPOSURE (MPE).....	13
APPLICABLE STANDARD	13
FCC §15.203 – ANTENNA REQUIREMENT	15
APPLICABLE STANDARD	15
ANTENNA CONNECTOR CONSTRUCTION	15
FCC §15.407 (b) (6) §15.207 (a) –AC Power Line Conducted Emissions	16
APPLICABLE STANDARD	16
MEASUREMENT UNCERTAINTY	16
EUT SETUP	16
EMI TEST RECEIVER SETUP.....	17
CORRECTED AMPLITUDE & MARGIN CALCULATION	17
TEST EQUIPMENT LIST AND DETAILS.....	17
TEST PROCEDURE	18
TEST RESULTS SUMMARY	18
TEST DATA	18
§15.205 & §15.209 & §15.407(B) (1),(6),(7) – UNDESIRABLE EMISSION & RESTRICTED BANDS.....	21
APPLICABLE STANDARD	21
MEASUREMENT UNCERTAINTY	21
EUT SETUP	22
EMI TEST RECEIVER & SPECTRUM ANALYZER SETUP	23
TEST PROCEDURE	23
CORRECTED AMPLITUDE & MARGIN CALCULATION	23
TEST EQUIPMENT LIST AND DETAILS.....	24
TEST RESULTS SUMMARY	24
TEST DATA	24
FCC §15.407(b) (1) (2) (3) (4) –BAND EDGE	33
APPLICABLE STANDARD	33
TEST PROCEDURE	33
TEST EQUIPMENT LIST AND DETAILS.....	33

TEST DATA	34
FCC §15.407(a) & §15.407(e)–EMISSION BANDWIDTH.....	43
APPLICABLE STANDARD	43
TEST EQUIPMENT LIST AND DETAILS.....	43
TEST PROCEDURE	43
TEST DATA	44
FCC §15.407(a) (1) – CONDUCTED TRANSMITTER OUTPUT POWER.....	50
APPLICABLE STANDARD	50
TEST EQUIPMENT LIST AND DETAILS.....	50
TEST PROCEDURE	50
TEST DATA	51
FCC §15.407(a) - POWER SPECTRAL DENSITY	53
APPLICABLE STANDARD	53
TEST PROCEDURE	53
TEST EQUIPMENT LIST AND DETAILS.....	54
TEST DATA	54

GENERAL INFORMATION

Product Description for Equipment under Test (EUT)

The Huawei Technologies Co., Ltd 's product, model number: AP2030DN (FCC ID: QISAP2030DN) or the "EUT" in this report was a Wireless LAN Access Point, rated input voltage: DC voltage supplied From Adapter or PoE.

Adapter information:

Brand :HUAWEI

Model:HUAWEI/HW-120200U1W

AC INPUT: 100-240V, 0.8A,50-60Hz

DC OUTPUT: 12V, 2.0A

Manufacture information:

Huawei Technologies Co., Ltd / administration Building ,Headquarters of Huawei Technologies Co., Ltd ., Bantian,longgang District,Shenzhen,518129,P.R.C,China

**All measurement and test data in this report was gathered from production sample serial number: 20161018001. (Assigned by the BACL. The EUT supplied by the applicant was received on 2016-10-18)*

Antenna information

Chain	Antenna Type	Max. Antenna Gain
0	PCB Antenna	5.3dBi
1	PCB Antenna	5.2dBi

Objective

This type approval report is prepared on behalf of Huawei Technologies Co., Ltd in accordance with Part 2-Subpart J, Part 15-Subparts A, B and E of the Federal Communication Commissions rules.

The tests were performed in order to determine compliance with FCC Part 15, Subpart E, section 15.203, 15.205, 15.207, 15.209 and 15.407 rules.

Related Submittal(s)/Grant(s)

FCC Part 15B JBP and FCC Part 15.247 DTS and submission with FCC ID: QISAP2030DN.

Test Methodology

All measurements contained in this report were conducted with ANSI C63.10-2013, American National Standard of Procedures for Compliance Testing of Unlicensed Wireless Devices, and:

KDB 789033 D02 General UNII Test Procedures New Rules v01r03

662911 D01 Multiple Transmitter Output v02r01

ANSI C63.10-2013

All emissions measurement was performed and Bay Area Compliance Laboratories Corp. (Kunshan).

Test Facility

The test site used by Bay Area Compliance Laboratories Corp. (Kunshan) to collect test data is located on No.248 Chenghu Road, Kunshan, Jiangsu province, China

Test site at Bay Area Compliance Laboratories Corp. (Kunshan) has been fully described in reports submitted to the Federal Communication Commission (FCC). The details of these reports have been found to be in compliance with the requirements of Section 2.948 of the FCC Rules on November 06, 2014. The facility also complies with the radiated and AC line conducted test site criteria set forth in ANSI C63.4.

The Federal Communications Commission has the reports on file and is listed under FCC Registration No.: 815570. The test site has been approved by the FCC for public use and is listed in the FCC Public Access Link (PAL) database.

SYSTEM TEST CONFIGURATION

Description of Test Configuration

The EUT was configured for testing in an engineering mode which was provided by the manufacturer.

The system support 802.11a/n ht20/n ht40/ac vht20/ac vht40/ac vht80, the vh20/vht40 were reduced since the identical parameters with 802.11n ht20 and ht40. 802.11n and 802.11ac supports both beamforming and non-beamforming modes.

For 5725~5850MHz band, 8 channels are provided to testing:

Channel	Frequency (MHz)	Channel	Frequency (MHz)
149	5745	157	5785
151	5755	159	5795
153	5765	161	5805
155	5775	165	5825

The worst-case data rates are determined to be as follows for each mode based upon investigations by measuring the average power and PSD across all data rates bandwidths, and modulations. Preliminary tests were performed in difference data rate and all the possible configurations, the worst cases as below table and shown in the report.

Configurations	Test Mode	Data Rate	Channel	Antenna Chain
SISO	802.11a	6Mbps	149, 157, 165	0, 1
	802.11n ht20	MCS0	149, 157, 165	0, 1
	802.11n ht40	MCS0	151, 159	0, 1
	802.11ac 80	MNSS 0	155	0, 1
2*2 MIMO Non-Beamforming	802.11a	6Mbps	149, 157, 165	0+1
	802.11n ht20	MCS0_20	149, 157, 165	0+1
	802.11n ht40	MCS0_40	151, 159	0+1
	802.11ac 80	MNSS 0	155	0+1
2*2 MIMO Beamforming	802.11n ht20	MCS0	149, 157, 165	0+1
	802.11n ht40	MCS0	151, 159	0+1
	802.11ac 80	MNSS 0	155	0+1

EUT Exercise Software

The IPOR&QSPR was used for testing, and the commands were provided by manufacturer. The maximum power and duty cycle was set by commands as following table:

1TX:

Software and version				IPOR&QSPR		
UNII Band	Mode	Channel	Frequency (MHz)	Data Rate (Mbps)	Power Level	
					Chain 0	Chain 1
5725-5850MHz	802.11 a	Low	5745	6	17	17
		Middle	5785	6	17	17
		High	5825	6	17	17
	802.11 n20	Low	5745	MCS0_20	16	16
		Middle	5785	MCS0_20	16	16
		High	5825	MCS0_20	16	16
	802.11 n40	Low	5755	MCS0_40	16	16
		High	5795	MCS0_40	16	16
	802.11 ac80	Middle	5775	AC-MCS0_80	15	15

2TX Non-beamforming:

Software and version				IPOR&QSPR		
UNII Band	Mode	Channel	Frequency (MHz)	Data Rate (Mbps)	Power Level	
					Chain 0&Chain 1	
5725-5850MHz	802.11 a	Low	5745	6	17	
		Middle	5785	6	17	
		High	5825	6	17	
	802.11 n20	Low	5745	MCS0_20	16	16
		Middle	5785	MCS0_20	16	16
		High	5825	MCS0_20	16	16
	802.11 n40	Low	5755	MCS0_40	16	16
		High	5795	MCS0_40	16	16
	802.11 ac80	Middle	5775	AC-MCS0_80	15	15

2TX with beamforming:

Software and version				IPOR&QSPR		
UNII Band	Mode	Channel	Frequency (MHz)	Data Rate (Mbps)	Power Level	
					Chain 0&Chain 1	
5725-5850MHz	802.11 n20	Low	5745	MCS0_20	16	
		Middle	5785	MCS0_20	16	
		High	5825	MCS0_20	16	
	802.11 n40	Low	5755	MCS0_40	16	16
		High	5795	MCS0_40	16	16
	802.11 ac80	Middle	5775	AC-MCS0_80	15	15

The duty cycle as below:

UNII Band	Mode	T _{on} (ms)	T _{on+off} (ms)	Duty Cycle (%)	Minimum Transmission Duration (T) (ms)
5725-5850MHz	802.11a	2.07	2.13	97	2.07
	802.11n ht20	1.92	1.99	96	1.92
	802.11n ht40	0.948	1.004	94	0.948
	802.11 ac80	0.465	0.522	89	0.465

802.11a

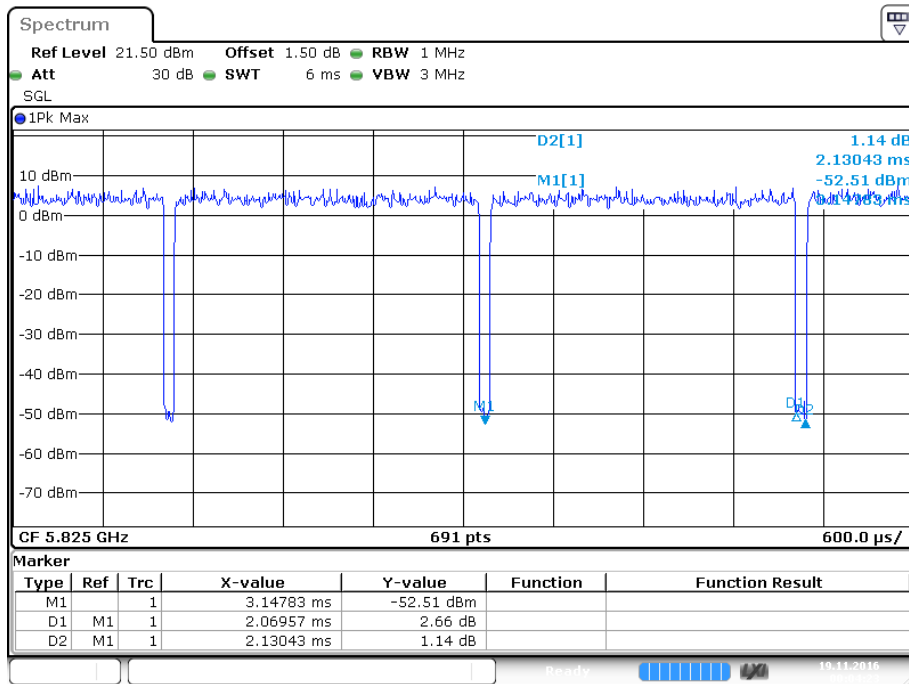

802.11n ht20

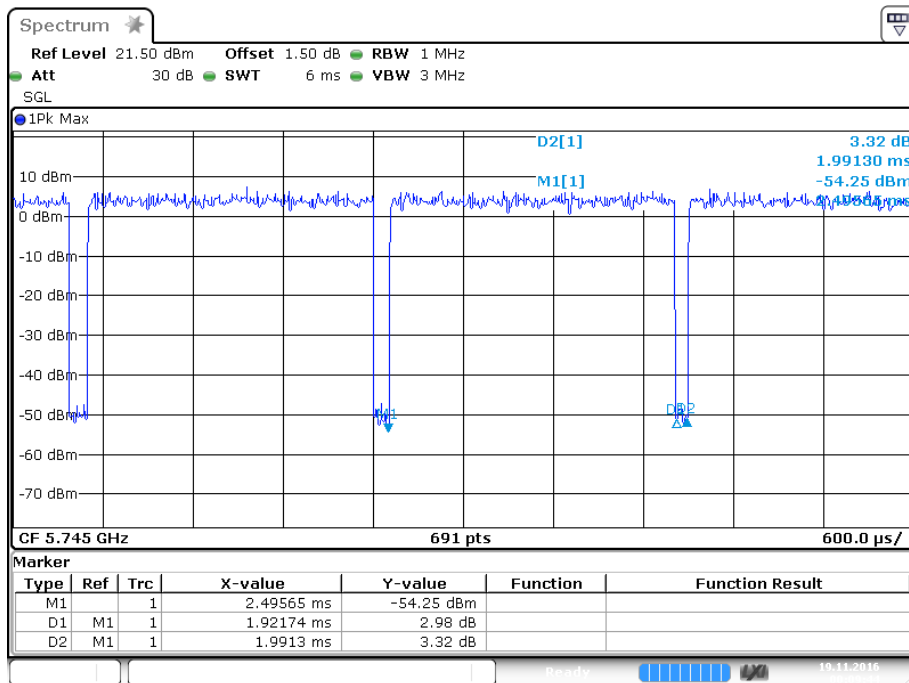

802.11n ht40

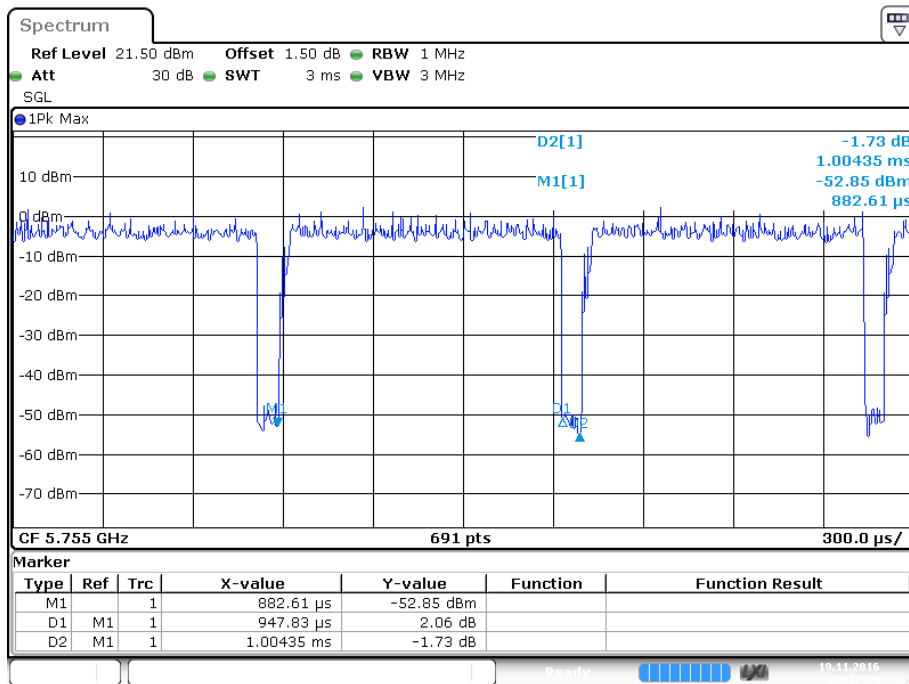

Date: 19.NOV.2016 00:17:24

802.11ac80

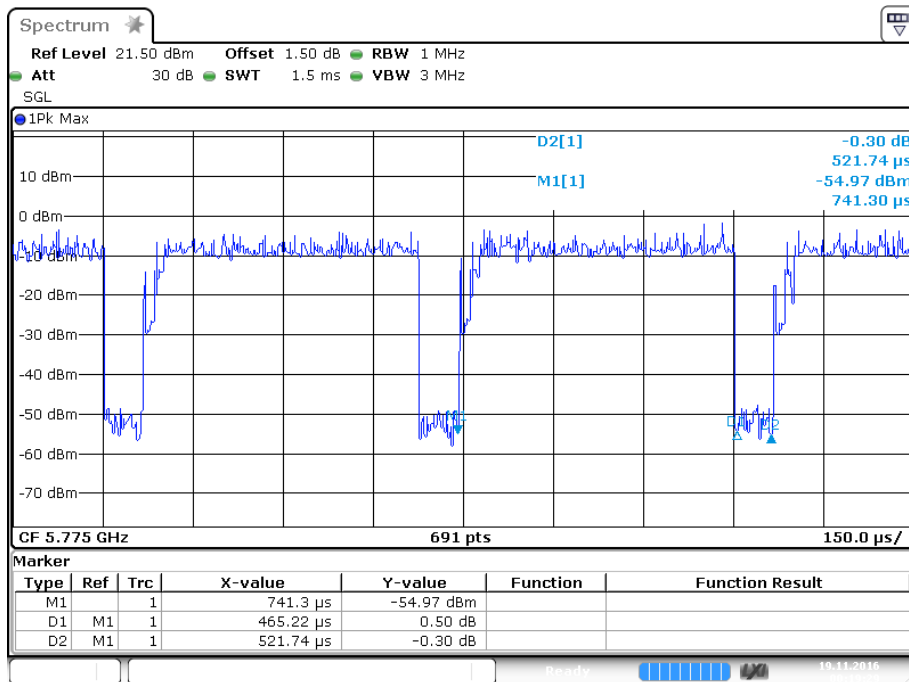

Date: 19.NOV.2016 00:19:28

Equipment Modifications

N/A.

Support Equipment List and Details

Manufacturer	Description	Model	Serial Number
HP	Laptop 1	5600U	5CG6240ZH1
DELL	Laptop 2	D420	0002530
N/A	Load	N/A	N/A
AVAYA	Phone	6408D+	041611141185

External I/O Cable

Cable Description	Length (m)	From/Port	To
Un-shielding RJ 45 Cable	1.8	EUT	Laptop 1
Un-shielding RJ 45 Cable	1.0	EUT POE Port	POE Adapter
Un-shielding DC Cable	0.8	Adapter	EUT
Un-shielding RJ 11Cable	1.8	EUT	Phone
Un-shielding RJ 45 Cable*3	0.8	EUT	Load

Block Diagram of Test Setup

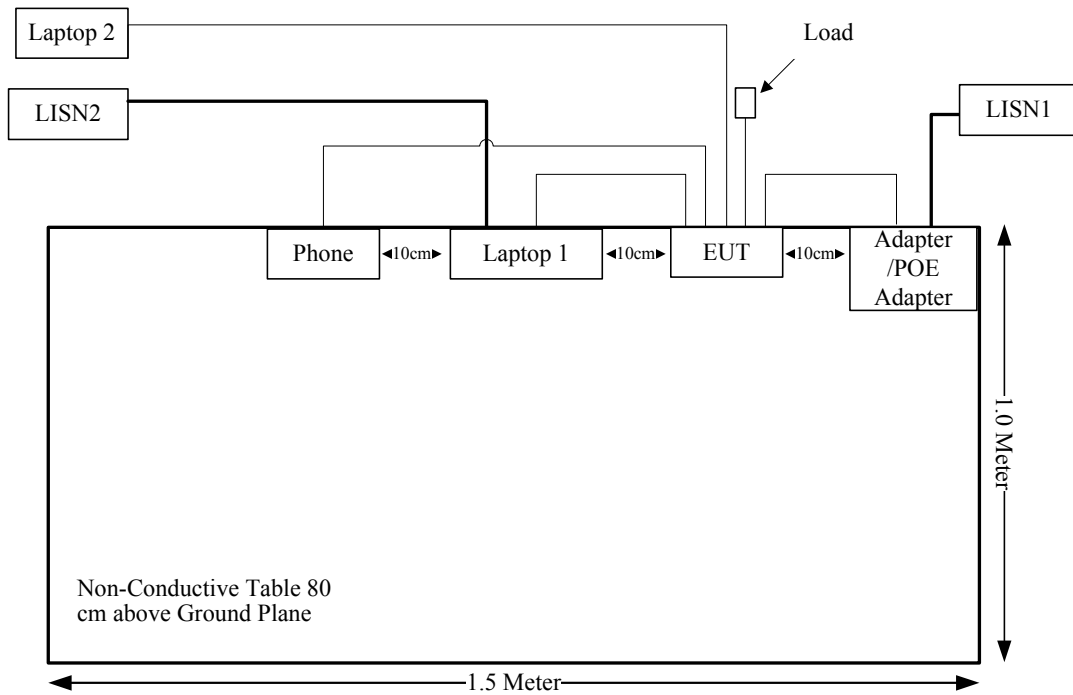

SUMMARY OF TEST RESULTS

FCC Rules	Description of Test	Result
§15.407(f) & §2.1091	MAXIMUM PERMISSIBLE EXPOSURE (MPE)	Compliance
§15.203	Antenna Requirement	Compliance
FCC §15.207 & §15.407(b) (6)	AC Power Line Conducted Emissions	Compliance
§ 15.205 & §15.209 & §15.407(b)	undesirable emission & restricted bands	Compliance
§15.407(b)	BAND EDGE	Compliance
§15.407(a) & §15.407 (e)	Emission Bandwidth	Compliance
§15.407 (a)	Conducted Transmitter Output Power	Compliance
§15.407 (a)	Power Spectral Density	Compliance

FCC §15.407(f) & §1.1310 & §2.1091- MAXIMUM PERMISSIBLE EXPOSURE (MPE)

Applicable Standard

According to §15.247(i) and §1.1310, systems operating under the provisions of this section shall be operated in a manner that ensure that the public is not exposed to radio frequency energy level in excess of the Commission’s guideline.

Limits for Maximum Permissible Exposure (MPE) (§1.1310, §2.1091)

(B) Limits for General Population/Uncontrolled Exposure				
Frequency Range (MHz)	Electric Field Strength (V/m)	Magnetic Field Strength (A/m)	Power Density (mW/cm²)	Averaging Time (minutes)
0.3–1.34	614	1.63	*(100)	30
1.34–30	824/f	2.19/f	*(180/f ²)	30
30–300	27.5	0.073	0.2	30
300–1500	/	/	f/1500	30
1500–100,000	/	/	1.0	30

f = frequency in MHz; * = Plane-wave equivalent power density;

According to §1.1310 and §2.1091 RF exposure is calculated.

Calculated Formulary:

Predication of MPE limit at a given distance

S = PG/4 π R² = power density (in appropriate units, e.g. mW/cm²);

P = power input to the antenna (in appropriate units, e.g., mW);

G = power gain of the antenna in the direction of interest relative to an isotropic radiator, the power gain factor, is normally numeric gain;

R = distance to the center of radiation of the antenna (appropriate units, e.g., cm);

For simultaneously transmit system, the calculated power density should comply with:

$$\sum_i \frac{S_i}{S_{Limit,i}} \leq 1$$

Calculated Data:

Frequency Band	Maximum Directional Gain		Maximum power including turn-up tolerance		Evaluation Distance (cm)	Power Density (mW/cm ²)	MPE Limit (mW/cm ²)
	(dBi)	(numeric)	(dBm)	(mW)			
2.4GHz	6.56	4.53	22	158.49	20.00	0.1429	1
5.8GHz	8.26	6.70	20	100.00	20.00	0.1333	1

Note: the antenna gain is Maximum Directional Gain, please refer to the conducted output power test section for detail.

The 2.4GHz and 5GHz band can transmit simultaneously:

$$\sum_i \frac{S_i}{S_{Limit,i}}$$

$$=S_{2.4}/S_{limit-2.4} + S_5/S_{limit-5}$$

$$=0.14/1+0.13/1$$

$$=0.27$$

$$< 1.0$$

Result: Compliance, The device meets MPE requirement for Devices Used by the General Public (Uncontrolled Environment) at distance ≥ 20 cm.

FCC §15.203 – ANTENNA REQUIREMENT

Applicable Standard

According to § 15.203, an intentional radiator shall be designed to ensure that no antenna other than that furnished by the responsible party shall be used with the device. The use of a permanently attached antenna or of an antenna that uses a unique coupling to the intentional radiator shall be considered sufficient to comply with the provisions of this section. The manufacturer may design the unit so that a broken antenna can be replaced by the user, but the user of a standard antenna jack or electrical connector is prohibited. The structure and application of the EUT were analyzed to determine compliance with section §15.203 of the rules. §15.203 state that the subject device must meet the following criteria:

- a. Antenna must be permanently attached to the unit.
- b. Antenna must use a unique type of connector to attach to the EUT.

Unit must be professionally installed, and installer shall be responsible for verifying that the correct antenna is employed with the unit.

And according to FCC 47 CFR section 15.247 (b), if the transmitting antennas of directional gain greater than 6 dBi are used, the power shall be reduced by the amount in dB that the directional gain of the antenna exceeds 6 dBi.

Antenna Connector Construction

The EUT has two PCB antenna arrangement for wifi, the antenna gain are 5.3dBi and 5.2 dBi@5GHz band, fulfill the requirement of this section. Please refer to the EUT photos.

Result: Compliance.

FCC §15.407 (b) (6) §15.207 (a) –AC Power Line Conducted Emissions

Applicable Standard

FCC §15.207, §15.407(b) (6)

Measurement Uncertainty

Compliance or non-compliance with a disturbance limit shall be determined in the following manner:

If U_{lab} is less than or equal to U_{cispr} of Table 1, then:

- compliance is deemed to occur if no measured disturbance level exceeds the disturbance limit;
- non-compliance is deemed to occur if any measured disturbance level exceeds the disturbance limit.

If U_{lab} is greater than U_{cispr} of Table 1, then:

- compliance is deemed to occur if no measured disturbance level, increased by $(U_{lab} - U_{cispr})$, exceeds the disturbance limit;
- non-compliance is deemed to occur if any measured disturbance level, increased by $(U_{lab} - U_{cispr})$, exceeds the disturbance limit.

Based on CISPR 16-4-2: 2011, measurement uncertainty of conducted disturbance at mains port using AMN at Bay Area Compliance Laboratories Corp. (Kunshan) is 3.46 dB (150 kHz to 30 MHz).

Table 1 – Values of U_{cispr}

Measurement	U_{cispr}
Conducted disturbance at mains port using AMN (150 kHz to 30 MHz)	3.4 dB

EUT Setup

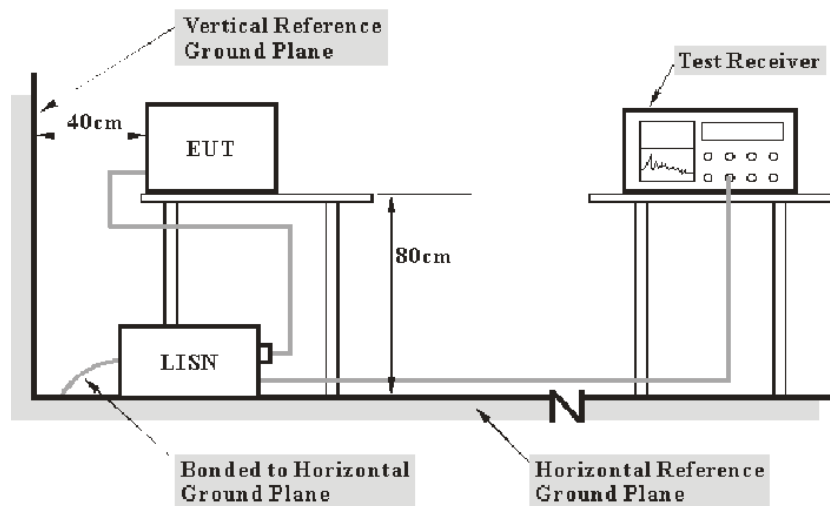

- Note: 1. Support units were connected to second LISN.
 2. Both of LISNs (AMN) 80 cm from EUT and at the least 80 cm from other units and other metal planes support units.

The setup of EUT is according with per ANSI C63.10-2013 measurement procedure. The specification used was with the FCC Part 15.207 limits.

The spacing between the peripherals was 10 cm.

The adapter was connected to a 120VAC/60 Hz power source.

EMI Test Receiver Setup

The EMI test receiver was set to investigate the spectrum from 150 kHz to 30 MHz

During the conducted emission test, the EMI test receiver was set with the following configurations:

Frequency Range	IF B/W
150 kHz – 30 MHz	9 kHz

Corrected Amplitude & Margin Calculation

The basic equation is as follows:

$$V_C = V_R + A_C + VDF$$

$$C_f = A_C + VDF$$

Herein,

V_C (cord. Reading): corrected voltage amplitude

V_R : reading voltage amplitude

A_C : attenuation caused by cable loss

VDF: voltage division factor of AMN

C_f : Correction Factor

The “**Margin**” column of the following data tables indicates the degree of compliance within the applicable limit. For example, a margin of 7dB means the emission is 7dB below the maximum limit. The equation for margin calculation is as follows:

$$\text{Margin} = \text{Limit} - \text{Corrected Amplitude}$$

Test Equipment List and Details

Manufacturer	Description	Model	Serial Number	Calibration Date	Calibration Due Date
Rohde & Schwarz	EMI Test Receiver	ESCS30	934115/007	2015-11-12	2016-11-11
Rohde & Schwarz	LISN	ESH3-Z5	862770/011	2015-11-12	2016-11-11
Rohde & Schwarz	LISN	ESH3-Z5	892239/018	2016-07-04	2017-07-03
Rohde & Schwarz	Pulse limiter	ESH3-Z2	879940/0058	2016-06-19	2017-06-18
HP	Current probe	8710-1744	636	2016-07-04	2017-07-03
FCC	ISN	FCC-TLISN-T8-02	20376	2016-06-23	2017-06-22
MICRO-COAX	Coaxial line	UFB-293B-1-0480-50X50	97F0173	2016-09-08	2017-09-08
Rohde & Schwarz	CE Test software	EMC 32	V 09.10.0	--	--

* **Statement of Traceability:** Bay Area Compliance Laboratories Corp. (Kunshan) attests that all calibrations have been performed, traceable to National Primary Standards and International System of Units (SI).

Test Procedure

During the conducted emission test, the adapter was connected to the first LISN and the other support equipments were connected to the outlet of the second LISN.

Maximizing procedure was performed on the six (6) highest emissions of the EUT.

All data was recorded in the Quasi-peak and average detection mode.

Test Results Summary

According to the recorded data in following table, the EUT complied with the FCC Part 15.207, with the worst margin reading of:

17.43dB at **0.455000** MHz in the N Line conducted mode

Test Data

Environmental Conditions

Temperature:	23.5 °C
Relative Humidity:	55 %
ATM Pressure:	100.3 kPa

The testing was performed by Edison Hu on 2016-10-24.

Test Mode: Transmitting

AC 120V/60 Hz, Line

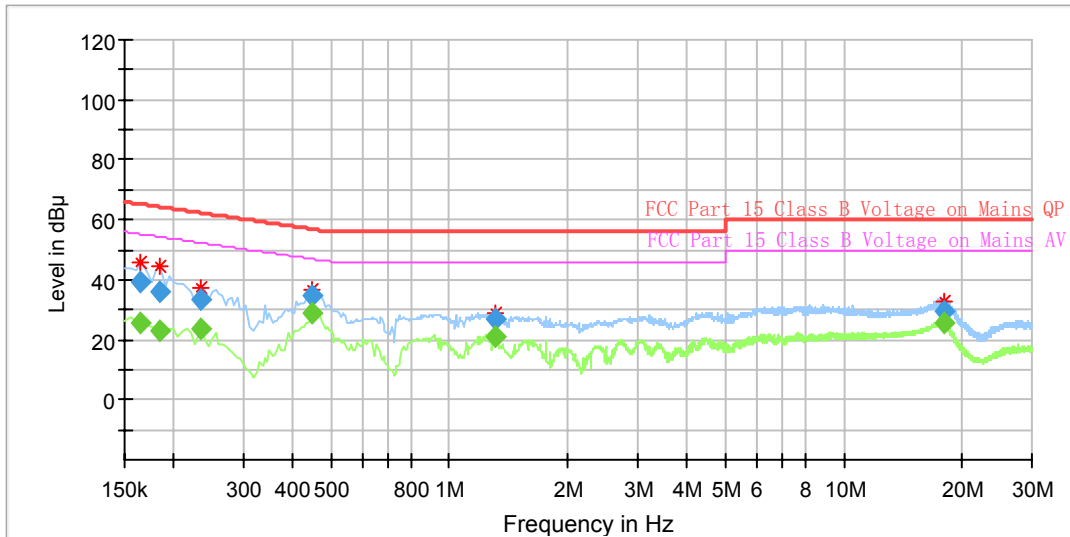

Frequency (MHz)	QuasiPeak (dBµV)	Average (dBµV)	Bandwidth (kHz)	Line	Corr. (dB)	Margin (dB)	Limit (dBµV)	Comment
0.165000	---	25.46	9.000	L1	10.3	29.75	55.21	Compliance
0.165000	39.36	---	9.000	L1	10.3	25.85	65.21	Compliance
0.185000	---	22.98	9.000	L1	10.3	31.28	54.26	Compliance
0.185000	36.23	---	9.000	L1	10.3	28.03	64.26	Compliance
0.235000	---	23.46	9.000	L1	10.3	28.81	52.27	Compliance
0.235000	33.68	---	9.000	L1	10.3	28.59	62.27	Compliance
0.450000	---	28.73	9.000	L1	10.3	18.15	46.88	Compliance
0.450000	34.41	---	9.000	L1	10.3	22.47	56.88	Compliance
1.300000	---	21.04	9.000	L1	10.3	24.96	46.00	Compliance
1.300000	26.60	---	9.000	L1	10.3	29.40	56.00	Compliance
17.900000	---	25.66	9.000	L1	10.5	24.34	50.00	Compliance
17.900000	29.62	---	9.000	L1	10.5	30.38	60.00	Compliance

AC 120V/60 Hz, Neutral

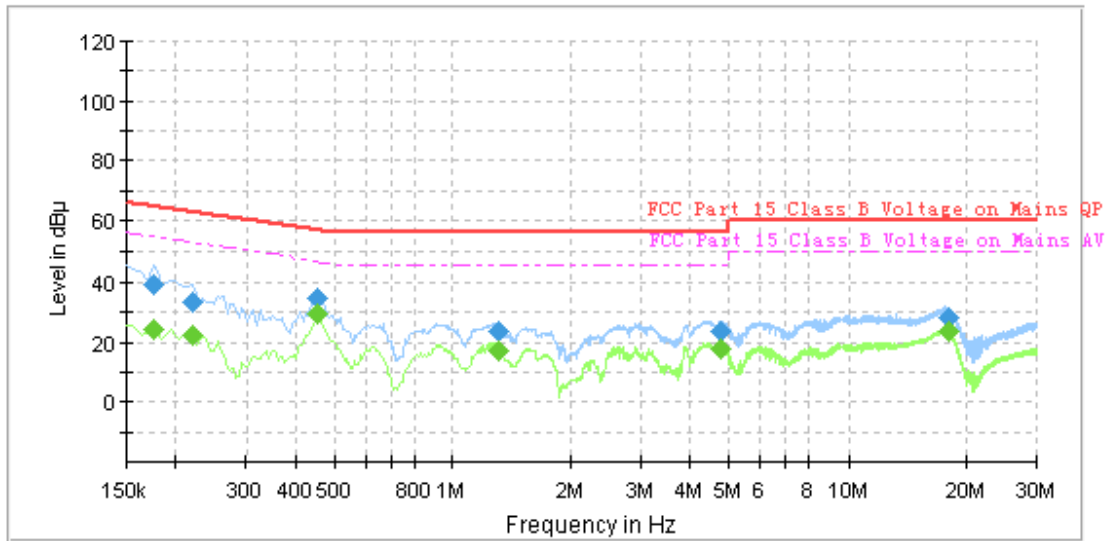

Frequency (MHz)	QuasiPeak (dBµV)	Average (dBµV)	Bandwidth (kHz)	Line	Corr. (dB)	Margin (dB)	Limit (dBµV)	Comment
0.175000	---	24.34	9.000	N	10.3	30.38	54.72	Compliance
0.175000	39.00	---	9.000	N	10.3	25.72	64.72	Compliance
0.220000	---	22.63	9.000	N	10.3	30.19	52.82	Compliance
0.220000	33.18	---	9.000	N	10.3	29.64	62.82	Compliance
0.455000	---	29.35	9.000	N	10.3	17.43	46.78	Compliance
0.455000	34.57	---	9.000	N	10.3	22.21	56.78	Compliance
1.310000	---	16.81	9.000	N	10.3	29.19	46.00	Compliance
1.310000	23.45	---	9.000	N	10.3	32.55	56.00	Compliance
4.780000	---	17.91	9.000	N	10.6	28.09	46.00	Compliance
4.780000	23.31	---	9.000	N	10.6	32.69	56.00	Compliance
17.905000	---	23.83	9.000	N	10.5	26.17	50.00	Compliance
17.905000	28.22	---	9.000	N	10.5	31.78	60.00	Compliance

- Note:**
 1) Corr.=LISN VDF (Voltage Division Factor) + Cable Loss
 2) Corrected Amplitude = Reading + Corr.
 3) Margin = Limit –Corrected Amplitude

§15.205 & §15.209 & §15.407(B) (1),(6),(7) – UNDESIRABLE EMISSION & RESTRICTED BANDS

Applicable Standard

FCC §15.407 (b); §15.209; §15.205;

For transmitters operating in the 5.15–5.25 GHz band: all emissions outside of the 5.15–5.35 GHz band shall not exceed an EIRP of –27dBm/MHz

For transmitters operating in the 5.25–5.35 GHz band: all emissions outside of the 5.15–5.35 GHz band shall not exceed an EIRP of –27 dBm/MHz. Devices operating in the 5.25–5.35 GHz band that generate emissions in the 5.15–5.25 GHz band must meet all applicable technical requirements for operation in the 5.15–5.25 GHz band (including indoor use) or alternatively meet an out-of-band emission EIRP limit of –27 dBm/MHz in the 5.15–5.25 GHz band.

For transmitters operating in the 5.47–5.725 GHz band: all emissions outside of the 5.47–5.725 GHz band shall not exceed an EIRP of –27 dBm/MHz.

For transmitters operating in the 5.725-5.85 GHz band: All emissions shall be limited to a level of –27 dBm/MHz at 75 MHz or more above or below the band edge increasing linearly to 10 dBm/MHz at 25 MHz above or below the band edge, and from 25 MHz above or below the band edge increasing linearly to a level of 15.6 dBm/MHz at 5 MHz above or below the band edge, and from 5 MHz above or below the band edge increasing linearly to a level of 27 dBm/MHz at the band edge.

As per FCC §15.35(d): Unless otherwise specified, on any frequency or frequencies above 1000MHz, the radiated emission limits are based on the use of measurement instrumentation employing an average detector function. Unless otherwise specified, measurements above 1000MHz shall be performed using a minimum resolution bandwidth of 1MHz.

According to KDB 789033 D02 General UNII Test Procedures New Rules v01, emission shall be computed as: $E [dB\mu V/m] = EIRP[dBm] + 95.2$, for $d = 3$ meters.

Measurement Uncertainty

Compliance or non-compliance with a disturbance limit shall be determined in the following manner:

If U_{lab} is less than or equal to U_{cispr} of Table 1, then:

- compliance is deemed to occur if no measured disturbance level exceeds the disturbance limit;
- non-compliance is deemed to occur if any measured disturbance level exceeds the disturbance limit.

If U_{lab} is greater than U_{cispr} of Table 1, then:

- compliance is deemed to occur if no measured disturbance level, increased by $(U_{lab} - U_{cispr})$, exceeds the disturbance limit;
- non-compliance is deemed to occur if any measured disturbance level, increased by $(U_{lab} - U_{cispr})$, exceeds the disturbance limit.

Based on CISPR 16-4-2: 2011, measurement uncertainty of radiated emission at a distance of 3m at Bay Area Compliance Laboratories Corp. (Kunshan) is:

30M~200MHz: 5.0 dB

200M~1GHz: 6.2 dB

1G~6GHz: 4.45 dB

6G~18GHz: 5.23 dB

Table 1 – Values of U_{cispr}

Measurement	U_{cispr}
Radiated disturbance (electric field strength at an OATS or in a SAC) (30 MHz to 1000 MHz)	6.3 dB
Radiated disturbance (electric field strength in a FAR) (1 GHz to 6 GHz)	5.2 dB
Radiated disturbance (electric field strength in a FAR) (6 GHz to 18 GHz)	5.5 dB

EUT Setup

Below 1 G:

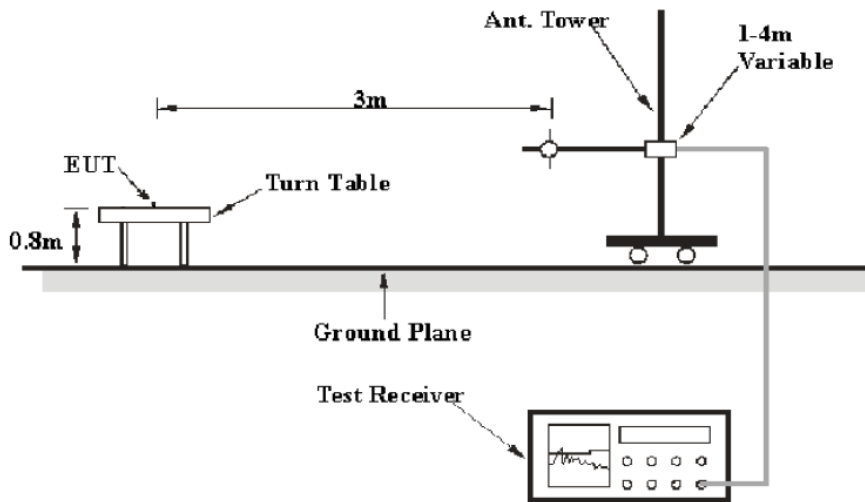

Above 1 G:

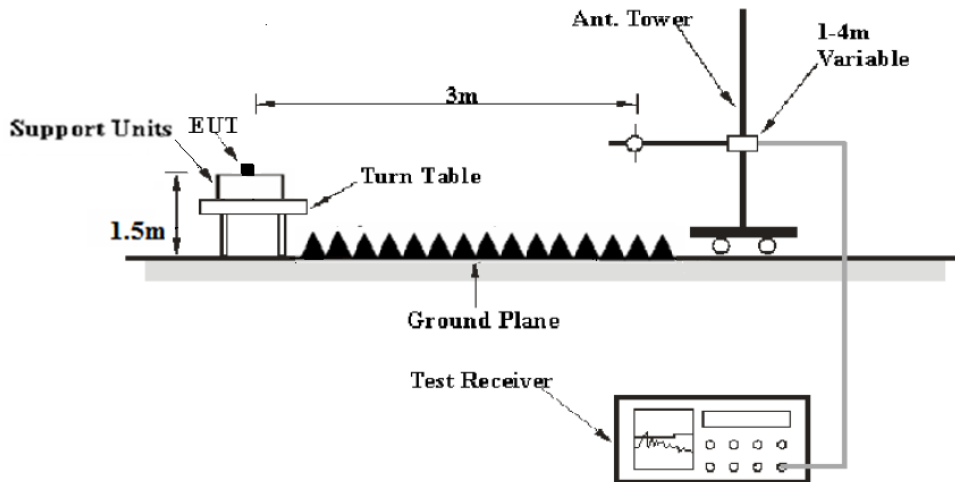

The setup of EUT is according with per ANSI C63.10-2013 measurement procedure. The specification used was with the FCC 15.209 and FCC 15.407 limits.

The external I/O cables were draped along the test table and formed a bundle 30 to 40 cm long in the middle.

The spacing between the peripherals was 10 cm.

The adapter was connected to a 120 VAC/60 Hz power source.

EMI Test Receiver & Spectrum Analyzer Setup

The system was investigated from 30 MHz to 40 GHz.

During the radiated emission test, the EMI test receiver & Spectrum Analyzer Setup were set with the following configurations:
30-1000MHz:

Frequency Range	RBW	Video B/W	IF B/W	Detector
30 MHz – 1000 MHz	120 kHz	300 kHz	120 kHz	QP

1GHz- 40GHz:

Detector	Duty cycle	RBW	Video B/W
PK	Any	1MHz	3 MHz
Ave.	>98%	1MHz	10 Hz
	<98%	1MHz	1/T

Test Procedure

During the radiated emission test, the adapter was connected to the first AC floor outlet and the other support equipments were connected to the second AC floor outlet.

Maximizing procedure was performed on the highest emissions to ensure that the EUT complied with all installation combinations.

Data was recorded in Quasi-peak detection mode for frequency range of 30 MHz-1GHz, peak and Average detection modes for frequencies above 1GHz.

The Radiated measurements was performed, The EIRP converted to field strength as follows:

According to C63.4, the above 1G test result shall be extrapolated to the specified distance using an extrapolation factor of 20dB/decade from 3m to 1.5m

Distance extrapolation factor = $20 \log(\text{specific distance [3m]}/\text{test distance [1.5m]})$ dB

Extrapolation result = Corrected Amplitude (dBμV/m) - distance extrapolation factor (6dB)

or Limit line = Specific limits(dBμV) + distance extrapolation factor (6dB)

Corrected Amplitude & Margin Calculation

The Corrected Amplitude is calculated by adding the Antenna Loss and Cable Loss, and subtracting the Amplifier Gain from the Meter Reading. The basic equation is as follows:

$$\text{Corrected Amplitude} = \text{Meter Reading} + \text{Antenna Loss} + \text{Cable Loss} - \text{Amplifier Gain}$$

The “**Margin**” column of the following data tables indicates the degree of compliance with the applicable limit. For example, a margin of 7dB means the emission is 7dB below the limit. The equation for margin calculation is as follows:

$$\text{Margin} = \text{Limit} - \text{Extrapolation result}$$

Test Equipment List and Details

Manufacturer	Description	Model	Serial Number	Calibration Date	Calibration Due Date
Sonoma Instrument	Amplifier	330	171377	2016-09-16	2017-09-16
Rohde & Schwarz	EMI Test Receiver	ESCI	100195	2015-11-12	2016-11-11
Sunol Sciences	Broadband Antenna	JB3	A090314-2	2015-11-07	2016-11-06
ETS	Horn Antenna	3115	6229	2015-11-07	2016-11-06
EMCO	Horn Antenna	3116	9510-2384	2015-11-07	2016-11-06
Rohde & Schwarz	SIGNALANALYZER	FSV40	101116	2016-07-04	2017-07-03
Rohde & Schwarz	Signal Analyzer	FSIQ26	100048	2015-11-12	2016-11-11
Mini	Pre-amplifier	ZVA-183-S+	857001418	2016-09-16	2017-09-16
DUCOMMUN	Pre-amplifier	ALN-22093530-01	990147	2016-09-16	2017-09-16
champrotek	Chamber	Chamber A	1#	2016-09-17	2017-09-17
R&S	Auto test Software	EMC32	V 09.10.0	-	-
BACL	RF cable	KS-LAB-012	KS-LAB-012	2015-12-16	2016-12-15
BACL	RF cable	KS-LAB-010	KS-LAB-010	2015-12-16	2016-12-15

* **Statement of Traceability:** Bay Area Compliance Laboratories Corp. (Kunshan) attests that all calibrations have been performed, traceable to National Primary Standards and International System of Units (SI).

Test Results Summary

According to the recorded data in following table, the EUT complied with the FCC Title 47, Part 15, Subpart C, Section 15.205, 15.209 and 15.407

Test Data**Environmental Conditions**

Temperature:	23.5 °C
Relative Humidity:	62 %
ATM Pressure:	99.9 kPa

The testing was performed by Edison Hu on 2016-11-6.

Mode: Transmitting

Note: For above 1GHz, the test distance is 1.5m.

Operation mode: Transmitting

30 MHz-1 GHz(2.4GHz band 802.11n ht40 2437MHz+5.8GHz band 802.11ac80 5775MHz was worst):

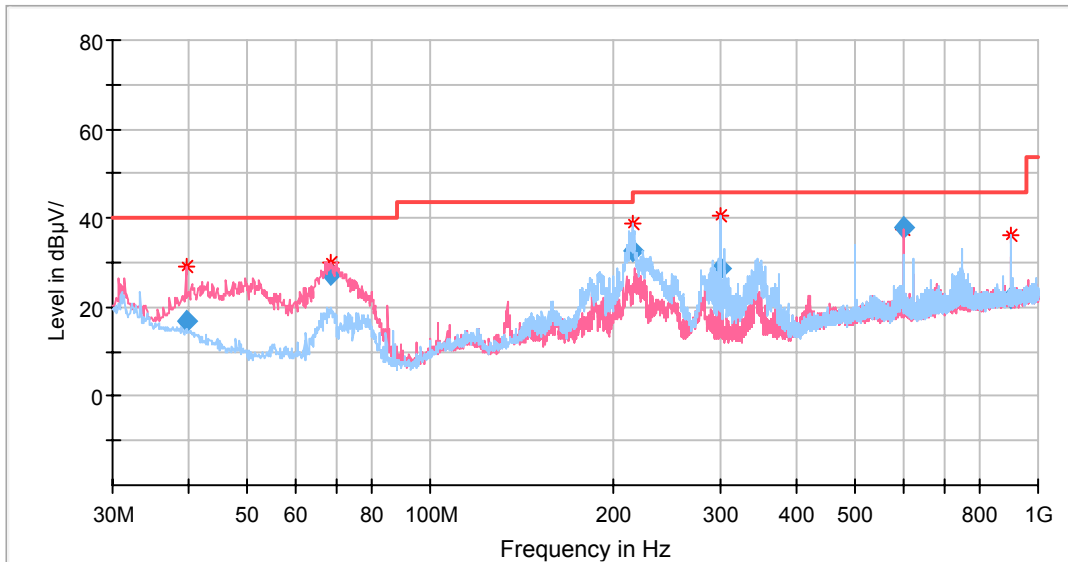

Frequency (MHz)	Receiver		Turntable Degree	Rx Antenna		Corrected Factor (dB)	Corrected Amplitude (dBµV/m)	FCC Part 15.209	
	Reading (dBµV)	Detector (PK/QP/Ave.)		Height (cm)	Polar (H/V)			Limit (dBµV/m)	Margin (dB)
33.459	30.62	QP	48	100	V	-6.9	23.72	40.0	16.28
81.9162	45.03	QP	148	100	V	-17	28.03	40.0	11.97
125.00505	52.33	QP	176	199	H	-14	38.33	43.5	5.17
250.00005	43.89	QP	15	199	H	-11.9	31.99	46.0	14.01
499.9998	44.73	QP	163	100	V	-5.6	39.13	46.0	6.87
749.9921	39.53	QP	31	100	V	-2.2	37.33	46.0	8.67

1~40GHz:
 Non-beamforming 802.11a Mode, (MIMO was the worst)

Frequency (MHz)	Receiver		Turntable Degree	Rx Antenna		Corrected Factor (dB)	Corrected Amplitude (dBµV/m)	Extrapolation result (dBµV/m)	Limit (dBµV/m)	Margin (dB)
	Reading (dBµV)	Detector (PK/QP/AV)		Height (cm)	Polar (H/V)					
Low Channel:5745 MHz										
5745.0	103.76	PK	155	200	H	10.3	114.06	108.06	/	/
5745.0	98.61	AV	155	200	H	10.3	108.91	102.91	/	/
5745.0	99.91	PK	155	200	V	10.3	110.21	104.21	/	/
5745.0	95.40	AV	155	200	V	10.3	105.70	99.70	/	/
5725.0	36.20	PK	160	150	H	10.3	46.50	40.50	74	33.50
5725.0	31.64	AV	160	150	H	10.3	41.94	35.94	54	18.06
11490.0	29.78	PK	0	100	V	21.1	50.88	44.88	74	29.12
11490.0	24.75	AV	0	100	V	21.1	45.85	39.85	54	14.15
17235.0	27.01	PK	120	200	H	30.8	57.81	51.81	74	22.19
17235.0	14.84	AV	120	200	H	30.8	45.64	39.64	54	14.36
6650.0	31.21	PK	123	300	V	14.1	45.31	39.31	74	34.69
6650.0	23.28	AV	123	300	V	14.1	37.38	31.38	54	22.62
Middle Channel:5785MHz										
5785.0	102.41	PK	155	200	H	10.3	112.71	106.71	/	/
5785.0	96.99	AV	155	200	H	10.3	107.29	101.29	/	/
5785.0	98.81	PK	155	200	V	10.3	109.11	103.11	/	/
5785.0	94.65	AV	155	200	V	10.3	104.95	98.95	/	/
11570.0	39.14	PK	160	150	H	21.1	60.24	54.24	74	19.76
11570.0	27.29	AV	160	150	H	21.1	48.39	42.39	54	11.61
17355.0	28.44	PK	0	100	V	30.8	59.24	53.24	74	20.76
17355.0	17.30	AV	0	100	V	30.8	48.10	42.10	54	11.90
6662.0	32.89	PK	120	200	H	14.1	46.99	40.99	74	33.01
6662.0	25.87	AV	120	200	H	14.1	39.97	33.97	54	20.03
7551.0	33.13	PK	123	300	V	17.2	50.33	44.33	74	29.67
7551.0	26.32	AV	123	300	V	17.2	43.52	37.52	54	16.48
High Channel:5825MHz										
5825.0	103.13	PK	155	200	H	10.3	113.43	107.43	/	/
5825.0	97.79	AV	155	200	H	10.3	108.09	102.09	/	/
5825.0	100.31	PK	155	200	V	10.3	110.61	104.61	/	/
5825.0	96.70	AV	155	200	V	10.3	107.00	101.00	/	/
5850.0	36.58	PK	160	150	H	10.3	46.88	40.88	74	33.12
5850.0	31.71	AV	160	150	H	10.3	42.01	36.01	54	17.99
11650.0	29.94	PK	0	100	V	21.1	51.04	45.04	74	28.96
11650.0	23.72	AV	0	100	V	21.1	44.82	38.82	54	15.18
17475.0	28.61	PK	120	200	H	30.8	59.41	53.41	74	20.59
17475.0	17.20	AV	120	200	H	30.8	48.00	42.00	54	12.00
6659.0	32.85	PK	123	300	V	14.1	46.95	40.95	74	33.05
6659.0	25.32	AV	123	300	V	14.1	39.42	33.42	54	20.58

Non-beamforming 802.11n ht20 Mode, (MIMO was the worst)

Frequency (MHz)	Receiver		Turntable Degree	Rx Antenna		Corrected Factor (dB)	Corrected Amplitude (dBµV/m)	Extrapolation result (dBµV/m)	Limit (dBµV/m)	Margin (dB)
	Reading (dBµV)	Detector (PK/QP/AV)		Height (cm)	Polar (H/V)					
Low Channel:5745 MHz										
5745.0	103.44	PK	143	200	H	10.3	113.74	107.74	/	/
5745.0	98.47	AV	143	200	H	10.3	108.77	102.77	/	/
5745.0	99.85	PK	166	200	V	10.3	110.15	104.15	/	/
5745.0	95.17	AV	166	200	V	10.3	105.47	99.47	/	/
5725.0	36.94	PK	160	150	H	10.3	47.24	41.24	74	32.76
5725.0	32.66	AV	160	150	H	10.3	42.96	36.96	54	17.04
11490.0	29.60	PK	40	100	V	21.1	50.70	44.70	74	29.30
11490.0	23.27	AV	40	100	V	21.1	44.37	38.37	54	15.63
17235.0	27.48	PK	120	200	H	30.8	58.28	52.28	74	21.72
17235.0	17.45	AV	120	200	H	30.8	48.25	42.25	54	11.75
6410.0	31.65	PK	123	300	V	14.1	45.75	39.75	74	34.25
6410.0	25.56	AV	123	300	V	14.1	39.66	33.66	54	20.34
Middle Channel:5785MHz										
5785.0	103.11	PK	143	200	H	10.3	113.41	107.41	/	/
5785.0	97.16	AV	143	200	H	10.3	107.46	101.46	/	/
5785.0	99.23	PK	166	200	V	10.3	109.53	103.53	/	/
5785.0	95.25	AV	166	200	V	10.3	105.55	99.55	/	/
11570.0	36.65	PK	160	150	H	21.1	57.75	51.75	74	22.25
11570.0	32.16	AV	160	150	H	21.1	53.26	47.26	54	6.74
17355.0	29.94	PK	40	100	V	30.8	60.74	54.74	74	19.26
17355.0	18.82	AV	40	100	V	30.8	49.62	43.62	54	10.38
6410.0	30.37	PK	120	200	H	14.1	44.47	38.47	74	35.53
6410.0	22.13	AV	120	200	H	14.1	36.23	30.23	54	23.77
7321.0	35.19	PK	123	300	V	17.2	52.39	46.39	74	27.61
7321.0	29.54	AV	123	300	V	17.2	46.74	40.74	54	13.26
High Channel:5825MHz										
5825.0	103.47	PK	143	200	H	10.3	113.77	107.77	/	/
5825.0	99.34	AV	143	200	H	10.3	109.64	103.64	/	/
5825.0	100.09	PK	166	200	V	10.3	110.39	104.39	/	/
5825.0	95.59	AV	166	200	V	10.3	105.89	99.89	/	/
5850.0	38.26	PK	160	150	H	10.3	48.56	42.56	74	31.44
5850.0	34.84	AV	160	150	H	10.3	45.14	39.14	54	14.86
11650.0	30.06	PK	40	100	V	21.1	51.16	45.16	74	28.84
11650.0	23.90	AV	40	100	V	21.1	45.00	39.00	54	15.00
17475.0	28.72	PK	120	200	H	30.8	59.52	53.52	74	20.48
17475.0	15.56	AV	120	200	H	30.8	46.36	40.36	54	13.64
6410.0	32.55	PK	123	300	V	14.1	46.65	40.65	74	33.35
6410.0	24.87	AV	123	300	V	14.1	38.97	32.97	54	21.03

Non-beamforming 802.11n ht40 Mode, (MIMO was the worst)

Frequency (MHz)	Receiver		Turntable Degree	Rx Antenna		Corrected Factor (dB)	Corrected Amplitude (dBµV/m)	Extrapolation result (dBµV/m)	Limit (dBµV/m)	Margin (dB)
	Reading (dBµV)	Detector (PK/QP/AV)		Height (cm)	Polar (H/V)					
Low Channel:5755 MHz										
5755.0	103.50	PK	140	200	H	10.3	113.80	107.80	/	/
5755.0	99.44	AV	140	200	H	10.3	109.74	103.74	/	/
5755.0	99.96	PK	166	200	V	10.3	110.26	104.26	/	/
5755.0	96.13	AV	166	200	V	10.3	106.43	100.43	/	/
5725.0	38.12	PK	160	150	H	10.3	48.42	42.42	74	31.58
5725.0	34.81	AV	160	150	H	10.3	45.11	39.11	54	14.89
11490.0	32.21	PK	40	100	V	21.1	53.31	47.31	74	26.69
11490.0	27.00	AV	40	100	V	21.1	48.10	42.10	54	11.90
17235.0	27.75	PK	110	200	H	30.8	58.55	52.55	74	21.45
17235.0	17.71	AV	110	200	H	30.8	48.51	42.51	54	11.49
6120.0	32.37	PK	123	300	V	14.1	46.47	40.47	74	33.53
6120.0	24.37	AV	123	300	V	14.1	38.47	32.47	54	21.53
High Channel:5795MHz										
5795.0	104.39	PK	140	200	H	10.3	114.69	108.69	/	/
5795.0	99.75	AV	140	200	H	10.3	110.05	104.05	/	/
5795.0	101.68	PK	166	200	V	10.3	111.98	105.98	/	/
5795.0	97.98	AV	166	200	V	10.3	108.28	102.28	/	/
5850.0	38.23	PK	160	150	H	10.3	48.53	42.53	74	31.47
5850.0	34.98	AV	160	150	H	10.3	45.28	39.28	54	14.72
11650.0	31.87	PK	40	100	V	21.1	52.97	46.97	74	27.03
11650.0	26.56	AV	40	100	V	21.1	47.66	41.66	54	12.34
17475.0	28.43	PK	110	200	H	30.8	59.23	53.23	74	20.77
17475.0	15.35	AV	110	200	H	30.8	46.15	40.15	54	13.85
6120.0	30.85	PK	123	300	V	14.1	44.95	38.95	74	35.05
6120.0	25.01	AV	123	300	V	14.1	39.11	33.11	54	20.89

Non-beamforming 802.11ac80 Mode, (MIMO was the worst):

Frequency (MHz)	Receiver		Turntable Degree	Rx Antenna		Corrected Factor (dB)	Corrected Amplitude (dBµV/m)	Extrapolation result (dBµV/m)	Limit (dBµV/m)	Margin (dB)
	Reading (dBµV)	Detector (PK/QP/AV)		Height (cm)	Polar (H/V)					
5775MHz										
5775.0	101.70	PK	120	150	H	10.3	112.00	106.00	/	/
5775.0	97.08	AV	120	150	H	10.3	107.38	101.38	/	/
5775.0	99.24	PK	66	200	V	10.3	109.54	103.54	/	/
5775.0	95.42	AV	66	200	V	10.3	105.72	99.72	/	/
5725.0	39.47	PK	161	150	H	10.3	49.77	43.77	74	30.23
5725.0	35.96	AV	161	150	H	10.3	46.26	40.26	54	13.74
5850.0	37.25	PK	212	150	H	21.1	58.35	52.35	74	21.65
5850.0	26.22	AV	212	150	H	21.1	47.32	41.32	54	12.68
11550.0	31.17	PK	76	150	V	30.8	61.97	55.97	74	18.03
11550.0	18.74	AV	76	150	V	30.8	49.54	43.54	54	10.46
17325.0	28.29	PK	0	200	H	14.1	42.39	36.39	74	37.61
17325.0	21.83	AV	0	200	H	14.1	35.93	29.93	54	24.07
6700.0	32.05	PK	310	150	V	17.2	49.25	43.25	74	30.75
6700.0	24.24	AV	310	150	V	17.2	41.44	35.44	54	18.56

beamforming 802.11n20 Mode:

Frequency (MHz)	Receiver		Turntable Degree	Rx Antenna		Corrected Factor (dB)	Corrected	Extrapolation	Limit (dBµV/m)	Margin (dB)
	Reading (dBµV)	Detector (PK/QP/AV)		Amplitude (dBµV/m)	result (dBµV/m)					
Low Channel:5745 MHz										
5745.0	103.69	PK	140	200	H	10.3	113.99	107.99	/	/
5745.0	99.57	AV	140	200	H	10.3	109.87	103.87	/	/
5745.0	100.70	PK	166	200	V	10.3	111.00	105.00	/	/
5745.0	96.32	AV	166	200	V	10.3	106.62	100.62	/	/
5725.0	38.42	PK	161	150	H	10.3	48.72	42.72	74	31.28
5725.0	34.37	AV	161	150	H	10.3	44.67	38.67	54	15.33
11490.0	32.63	PK	40	100	V	21.1	53.73	47.73	74	26.27
11490.0	26.81	AV	40	100	V	21.1	47.91	41.91	54	12.09
17235.0	27.76	PK	100	200	H	30.8	58.56	52.56	74	21.44
17235.0	20.01	AV	100	200	H	30.8	50.81	44.81	54	9.19
6416.0	31.05	PK	123	300	V	14.1	45.15	39.15	74	34.85
6416.0	25.94	AV	123	300	V	14.1	40.04	34.04	54	19.96
Middle Channel:5785MHz										
5785.0	102.31	PK	140	200	H	10.3	112.61	106.61	/	/
5785.0	96.71	AV	140	200	H	10.3	107.01	101.01	/	/
5785.0	98.80	PK	166	200	V	10.3	109.10	103.10	/	/
5785.0	95.66	AV	166	200	V	10.3	105.96	99.96	/	/
11570.0	36.03	PK	161	150	H	21.1	57.13	51.13	74	22.87
11570.0	27.44	AV	161	150	H	21.1	48.54	42.54	54	11.46
17355.0	27.51	PK	40	100	V	30.8	58.31	52.31	74	21.69
17355.0	17.67	AV	40	100	V	30.8	48.47	42.47	54	11.53
6416.0	31.37	PK	100	200	H	14.1	45.47	39.47	74	34.53
6416.0	24.06	AV	100	200	H	14.1	38.16	32.16	54	21.84
7380.0	30.15	PK	123	300	V	17.2	47.35	41.35	74	32.65
7380.0	23.66	AV	123	300	V	17.2	40.86	34.86	54	19.14
High Channel:5825MHz										
5825.0	103.67	PK	140	200	H	10.3	113.97	107.97	/	/
5825.0	98.91	AV	140	200	H	10.3	109.21	103.21	/	/
5825.0	100.95	PK	166	200	V	10.3	111.25	105.25	/	/
5825.0	96.33	AV	166	200	V	10.3	106.63	100.63	/	/
5850.0	37.65	PK	161	150	H	10.3	47.95	41.95	74	32.05
5850.0	32.51	AV	161	150	H	10.3	42.81	36.81	54	17.19
11650.0	29.18	PK	40	100	V	21.1	50.28	44.28	74	29.72
11650.0	22.88	AV	40	100	V	21.1	43.98	37.98	54	16.02
17475.0	29.83	PK	100	200	H	30.8	60.63	54.63	74	19.37
17475.0	16.98	AV	100	200	H	30.8	47.78	41.78	54	12.22
6416.0	31.13	PK	123	300	V	14.1	45.23	39.23	74	34.77
6416.0	25.29	AV	123	300	V	14.1	39.39	33.39	54	20.61

Beamforming 802.11n40 Mode

Frequency (MHz)	Receiver		Turntable Degree	Rx Antenna		Corrected Factor (dB)	Corrected Amplitude (dBµV/m)	Extrapolation result (dBµV/m)	Limit (dBµV/m)	Margin (dB)
	Reading (dBµV)	Detector (PK/QP/AV)		Height (cm)	Polar (H/V)					
	Low Channel:5755 MHz									
5755.0	101.88	PK	140	200	H	10.3	112.18	106.18	/	/
5755.0	96.93	AV	140	200	H	10.3	107.23	101.23	/	/
5755.0	99.13	PK	166	200	V	10.3	109.43	103.43	/	/
5755.0	95.35	AV	166	200	V	10.3	105.65	99.65	/	/
5725.0	38.54	PK	161	150	H	10.3	48.84	42.84	74	31.16
5725.0	33.79	AV	161	150	H	10.3	44.09	38.09	54	15.91
11490.0	29.32	PK	40	100	V	21.1	50.42	44.42	74	29.58
11490.0	22.83	AV	40	100	V	21.1	43.93	37.93	54	16.07
17235.0	27.02	PK	109	200	H	30.8	57.82	51.82	74	22.18
17235.0	17.62	AV	109	200	H	30.8	48.42	42.42	54	11.58
6230.0	30.11	PK	123	300	V	14.1	44.21	38.21	74	35.79
6230.0	23.60	AV	123	300	V	14.1	37.70	31.70	54	22.30
High Channel:5795MHz										
5795.0	102.14	PK	140	200	H	10.3	112.44	106.44	/	/
5795.0	96.96	AV	140	200	H	10.3	107.26	101.26	/	/
5795.0	99.20	PK	166	200	V	10.3	109.50	103.50	/	/
5795.0	95.07	AV	166	200	V	10.3	105.37	99.37	/	/
5850.0	39.78	PK	161	150	H	10.3	50.08	44.08	74	29.92
5850.0	34.80	AV	161	150	H	10.3	45.10	39.10	54	14.90
11650.0	31.70	PK	40	100	V	21.1	52.80	46.80	74	27.20
11650.0	26.28	AV	40	100	V	21.1	47.38	41.38	54	12.62
17475.0	28.81	PK	109	200	H	30.8	59.61	53.61	74	20.39
17475.0	17.31	AV	109	200	H	30.8	48.11	42.11	54	11.89
6230.0	31.11	PK	123	300	V	14.1	45.21	39.21	74	34.79
6230.0	22.45	AV	123	300	V	14.1	36.55	30.55	54	23.45

Beamforming 802.11ac80 Mode

Frequency (MHz)	Receiver		Turntable Degree	Rx Antenna		Corrected Factor (dB)	Corrected Amplitude (dBµV/m)	Extrapolation result (dBµV/m)	Limit (dBµV/m)	Margin (dB)
	Reading (dBµV)	Detector (PK/QP/AV)		Height (cm)	Polar (H/V)					
Low Channel:5775 MHz										
5775.0	102.74	PK	120	150	H	10.3	113.04	107.04	/	/
5775.0	98.27	AV	120	150	H	10.3	108.57	102.57	/	/
5775.0	100.24	PK	66	200	V	10.3	110.54	104.54	/	/
5775.0	95.72	AV	66	200	V	10.3	106.02	100.02	/	/
5725.0	40.54	PK	161	150	H	10.3	50.84	44.84	74	29.16
5725.0	36.14	AV	161	150	H	10.3	46.44	40.44	54	13.56
5850.0	38.95	PK	212	150	H	21.1	60.05	54.05	74	19.95
5850.0	26.46	AV	212	150	H	21.1	47.56	41.56	54	12.44
11550.0	32.54	PK	76	150	V	30.8	63.34	57.34	74	16.66
11550.0	19.33	AV	76	150	V	30.8	50.13	44.13	54	9.87
17325.0	28.53	PK	0	200	H	14.1	42.63	36.63	74	37.37
17325.0	20.45	AV	0	200	H	14.1	34.55	28.55	54	25.45
6700.0	31.21	PK	310	150	V	17.2	48.41	42.41	74	31.59
6700.0	23.95	AV	310	150	V	17.2	41.15	35.15	54	18.85

Co-location(Test at 3m distance):

Frequency (MHz)	Receiver		Turntable Degree	Rx Antenna		Corrected Factor (dB)	Corrected Amplitude (dBµV/m)	Limit (dBµV/m)	Margin (dB)
(MHz)	Reading (dBµV)	Detector (PK/QP/Ave.)	Degree	Height (cm)	Polar (H/V)	(dB)	(dBµV/m)	(dBµV/m)	(dB)
2.4GHz band 802.11n ht40 2437MHz+5.8GHz band 802.11ac80 5775MHz Beamforming was worst									
4874.0	33.57	PK	83	172	V	7.3	40.87	74	33.13
4874.0	26.63	Ave	83	172	V	7.3	33.93	54	20.07
6677.0	29.85	PK	275	154	H	13.8	43.65	74	30.35
6677.0	22.12	Ave	275	154	H	13.8	35.92	54	18.08
7311.0	28.77	PK	149	248	H	16.3	45.07	74	28.93
7311.0	23.65	Ave	149	248	H	16.3	39.95	54	14.05
11570.0	39.14	PK	160	150	H	21.1	60.24	74	13.76
11570.0	27.29	AV	160	150	H	21.1	48.39	54	5.61
17355.0	28.44	PK	0	100	V	30.8	59.24	74	14.76
17355.0	17.30	AV	0	100	V	30.8	48.10	54	5.9
6662.0	32.89	PK	120	200	H	14.1	46.99	74	27.01
6662.0	25.87	AV	120	200	H	14.1	39.97	54	14.03
7551.0	33.13	PK	123	300	V	17.2	50.33	74	23.67
7551.0	26.32	AV	123	300	V	17.2	43.52	54	10.48

FCC §15.407(b) (1) (2) (3) (4) –BAND EDGE

Applicable Standard

FCC §15.407 (b) (1), (2), (3), (4);

For transmitters operating in the 5.15–5.25 GHz band: all emissions outside of the 5.15–5.35 GHz band shall not exceed an EIRP of -27dBm/MHz

For transmitters operating in the 5.25–5.35 GHz band: all emissions outside of the 5.15–5.35 GHz band shall not exceed an EIRP of -27 dBm/MHz. Devices operating in the 5.25–5.35 GHz band that generate emissions in the 5.15–5.25 GHz band must meet all applicable technical requirements for operation in the 5.15–5.25 GHz band (including indoor use) or alternatively meet an out-of-band emission EIRP limit of -27 dBm/MHz in the 5.15–5.25 GHz band.

For transmitters operating in the 5.47–5.725 GHz band: all emissions outside of the 5.47–5.725 GHz band shall not exceed an EIRP of -27 dBm/MHz.

For transmitters operating in the 5.725–5.850 GHz band: all emissions shall be limited to a level of -27 dBm/MHz at 75 MHz or more above or below the band edge increasing linearly to 10 dBm/MHz at 25 MHz above or below the band edge, and from 25 MHz above or below the band edge increasing linearly to a level of 15.6 dBm/MHz at 5 MHz above or below the band edge, and from 5 MHz above or below the band edge increasing linearly to a level of 27 dBm/MHz at the band edge.

Test Procedure

1. Check the calibration of the measuring instrument using either an internal calibration or a known signal from an external generator.
2. Position the EUT without connection to measurement instrument. Turn on the EUT and connect its antenna terminal to measurement instrument via a low loss cable. Then set it to any one measured frequency within its operating range, and make sure the instrument is operated in its linear range.
3. Set RBW to 1 MHz and VBW to 3MHz of spectrum analyzer. Offset the cable loss.
4. Measure the highest amplitude appearing on spectral display and set it as a reference level. Plot the graph with marking the highest point and edge frequency.
5. Repeat above procedures until all measured frequencies were complete.

Test Equipment List and Details

Manufacturer	Description	Model	Serial Number	Calibration Date	Calibration Due Date
Rohde & Schwarz	SIGNALANALYZER	FSV40	101116	2016-07-04	2017-07-03
BACL	RF cable	KS-LAB-012	KS-LAB-012	2015-12-16	2016-12-15

* **Statement of Traceability:** Bay Area Compliance Laboratories Corp. (Kunshan) attests that all calibrations have been performed, traceable to National Primary Standards and International System of Units (SI).

Test Data**Environmental Conditions**

Temperature:	23.5 °C
Relative Humidity:	60 %
ATM Pressure:	99.9 kPa

The testing was performed by Edison Hu on 2016-10-26 to 2016-11-08.

Please refer to the following plots.

Test Mode: Transmitting(SISO mode was tested)

Test Result: Pass. SISO mode was the worst mode since maximum output power per chain, all emissions below the limits more than 12dBc, so combined two chains meet the requirements also.

Note: The antenna gain is 8.3 dBi.

802.11a Chain0 Band Edge, Left Side

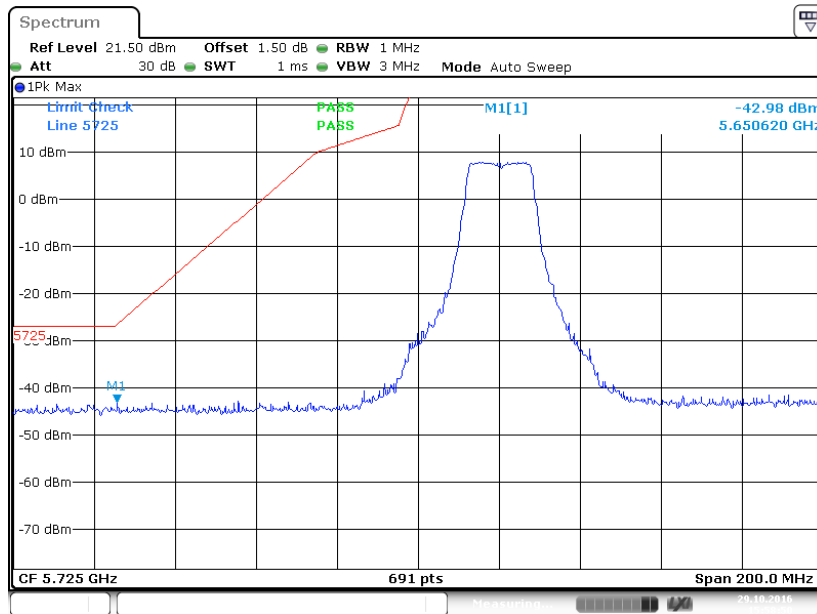

802.11a Chain0 Band Edge, Right Side

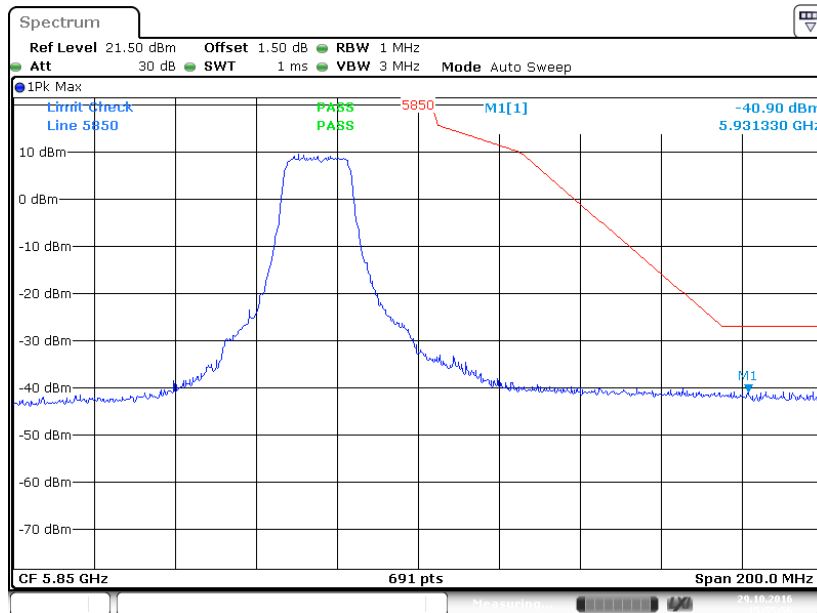

802.11n Chain0 ht20 Band Edge, Left Side

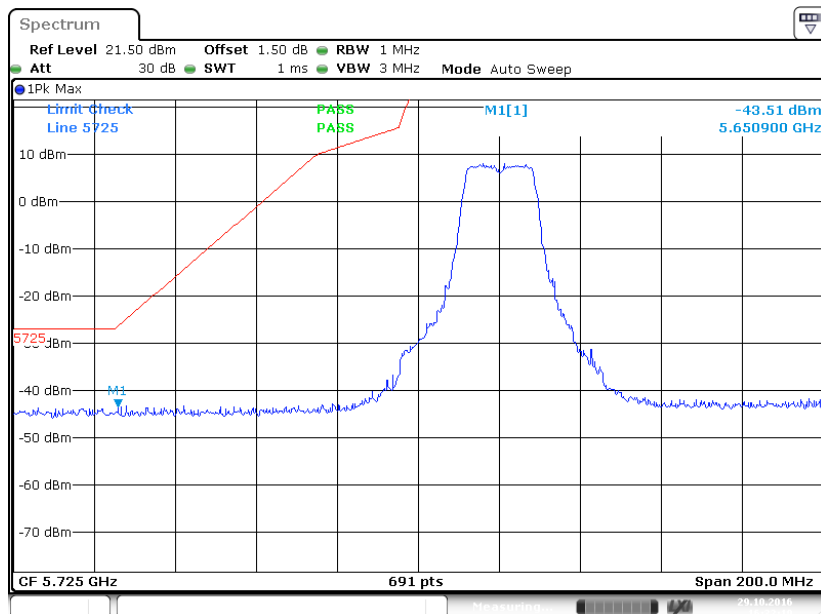

802.11n Chain0 ht20 Band Edge, Right Side

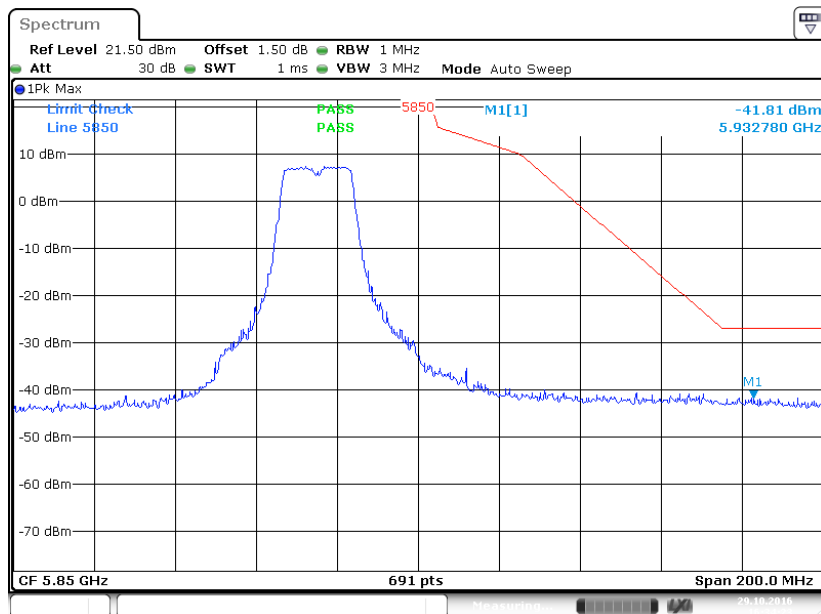

802.11n Chain0 ht40 Band Edge, Left Side

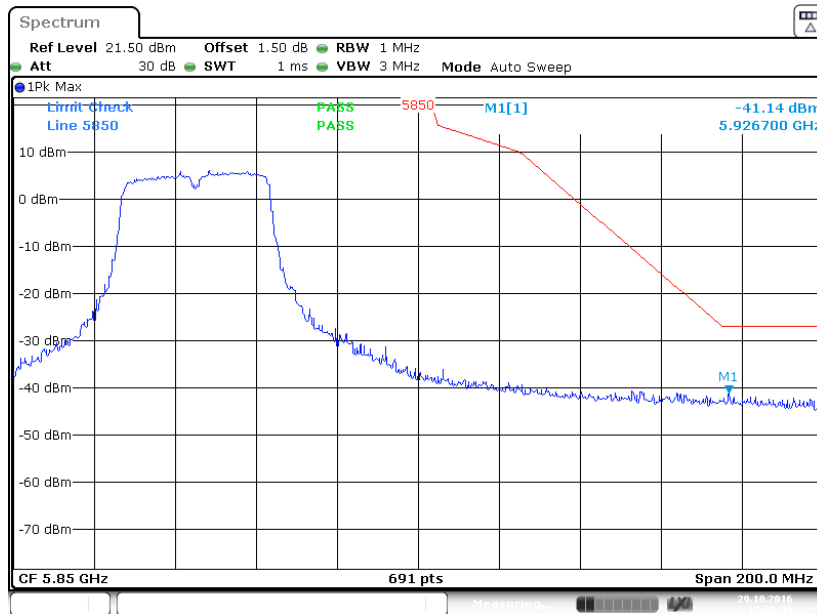

Date: 29.OCT.2016 17:16:42

802.11n Chain0 ht40 Band Edge, Right Side

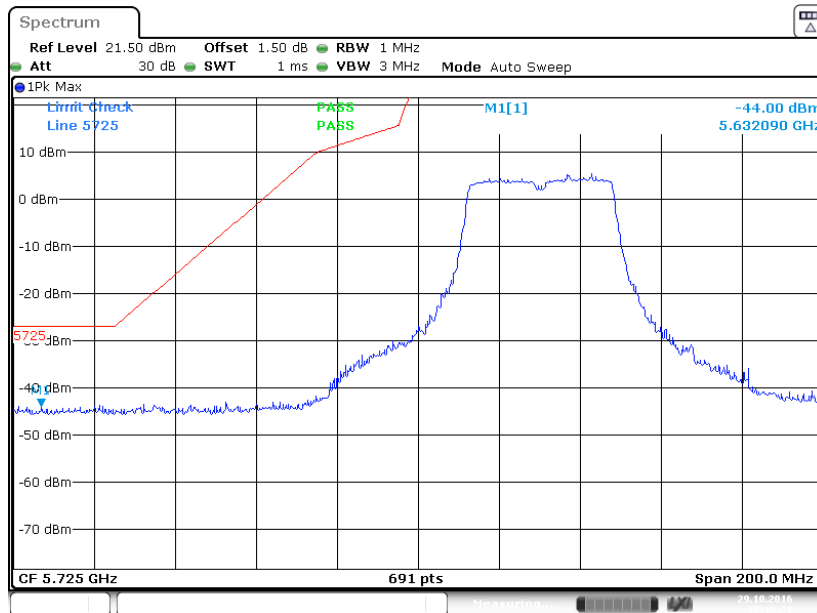

Date: 29.OCT.2016 17:15:22

802.11ac80 Chain0 Band Edge, Left Side

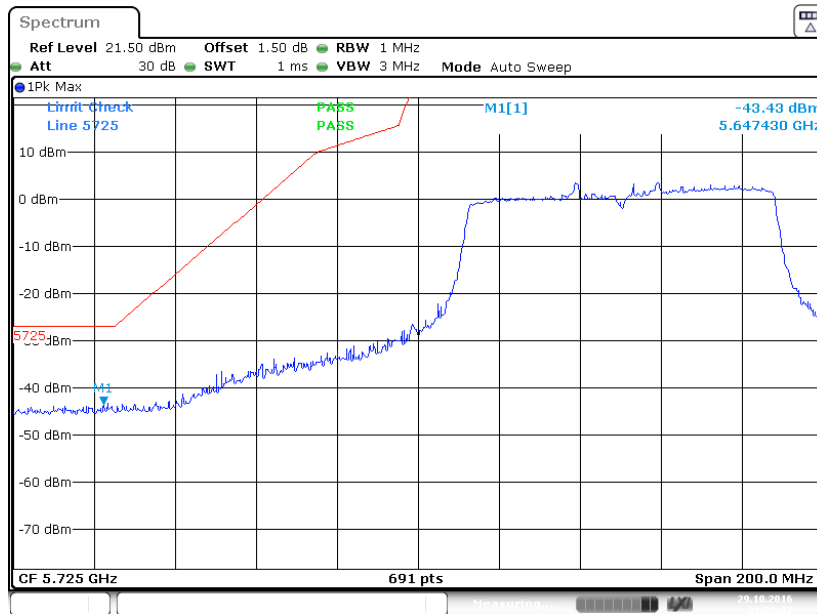

802.11ac80 Chain0 Band Edge, Right Side

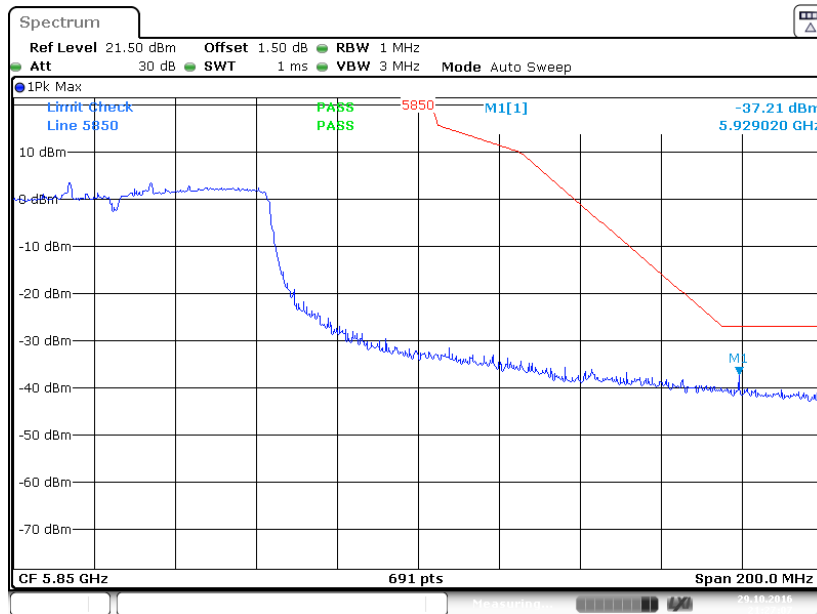

802.11a Chain1 Band Edge, Left Side

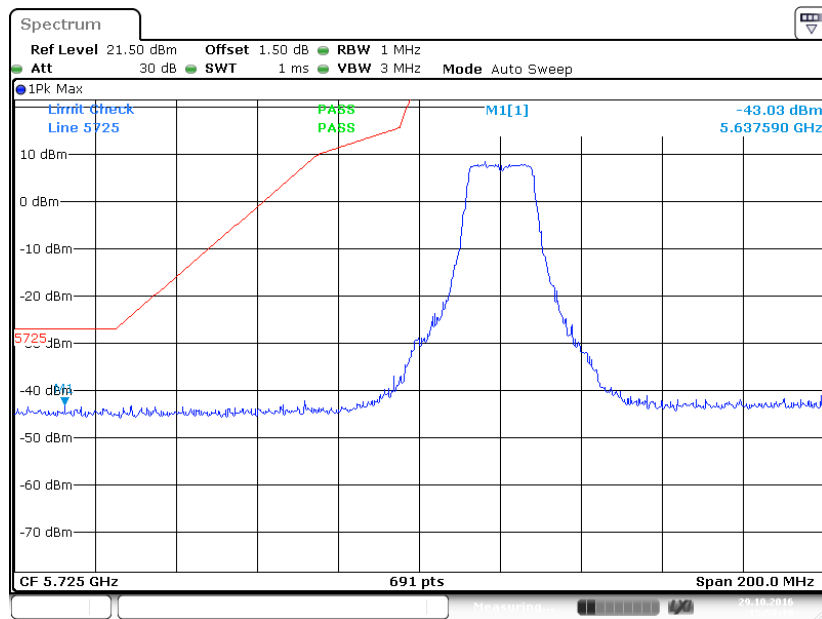

802.11a Chain1 Band Edge, Right Side

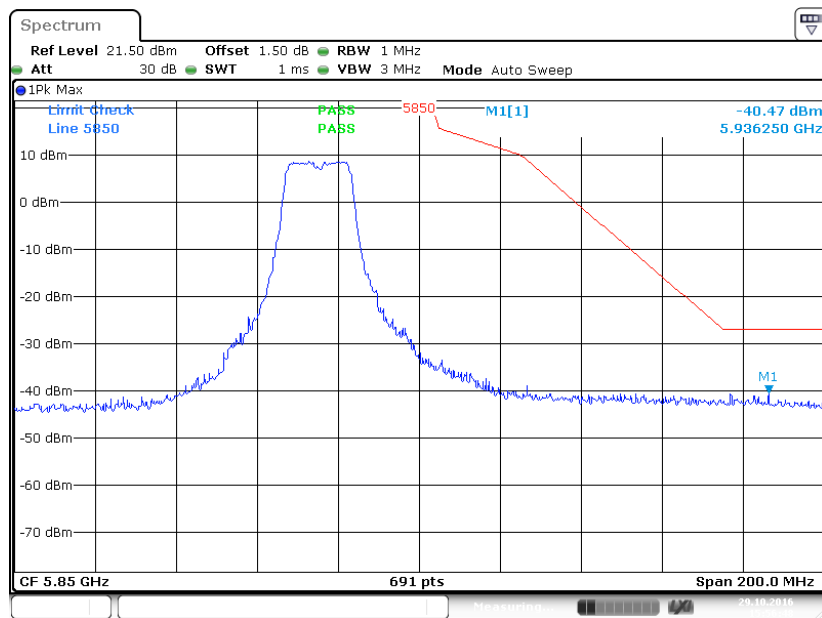

802.11n ht20 Chain1 Band Edge, Left Side

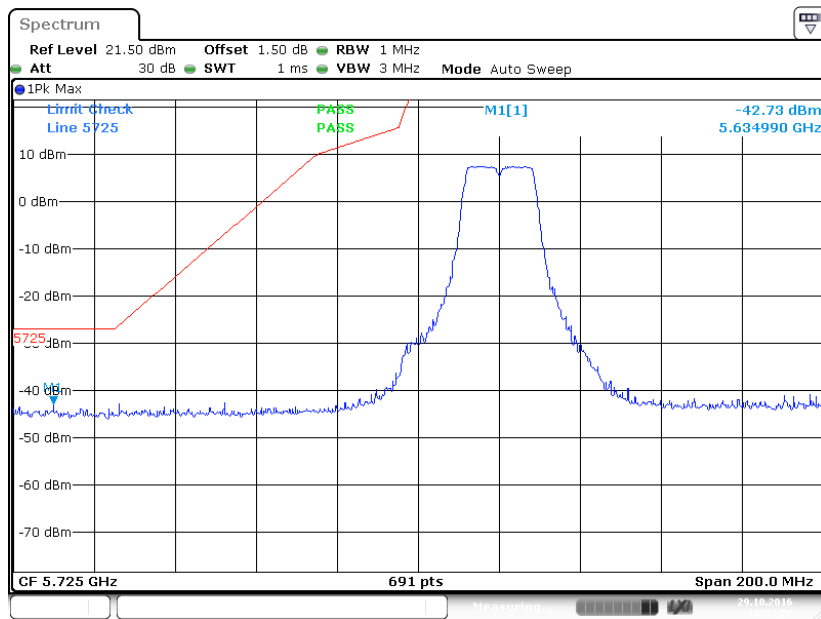

802.11n ht20 Chain1 Band Edge, Right Side

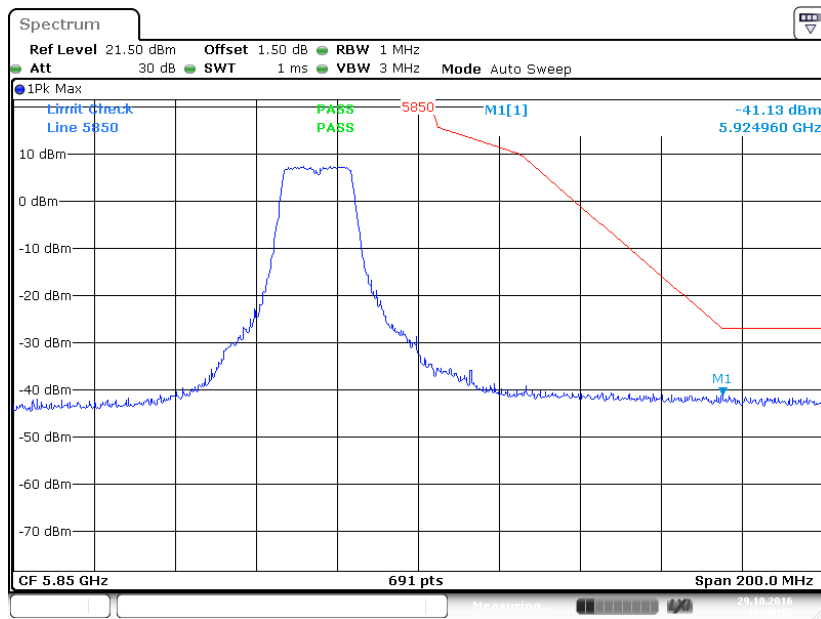

802.11n ht40 Chain1 Band Edge, Left Side

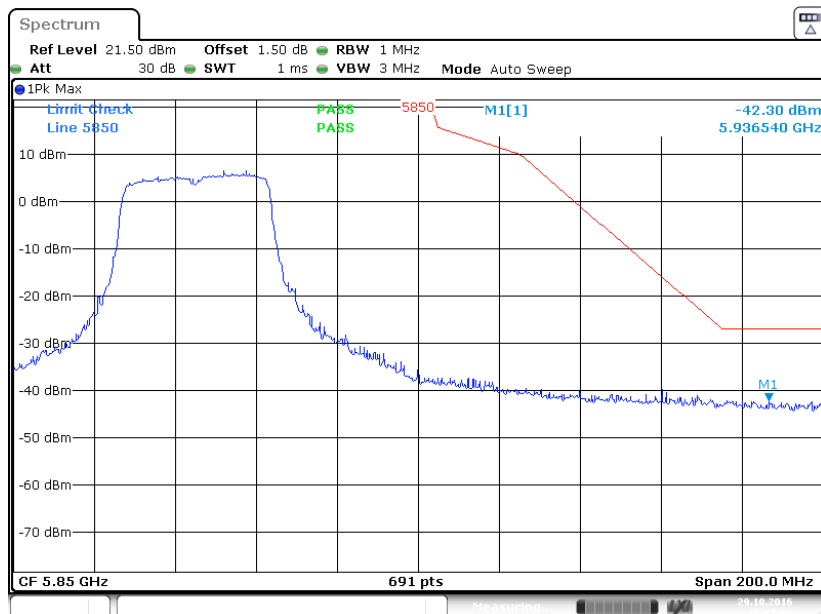

802.11n ht40 Chain1 Band Edge, Right Side

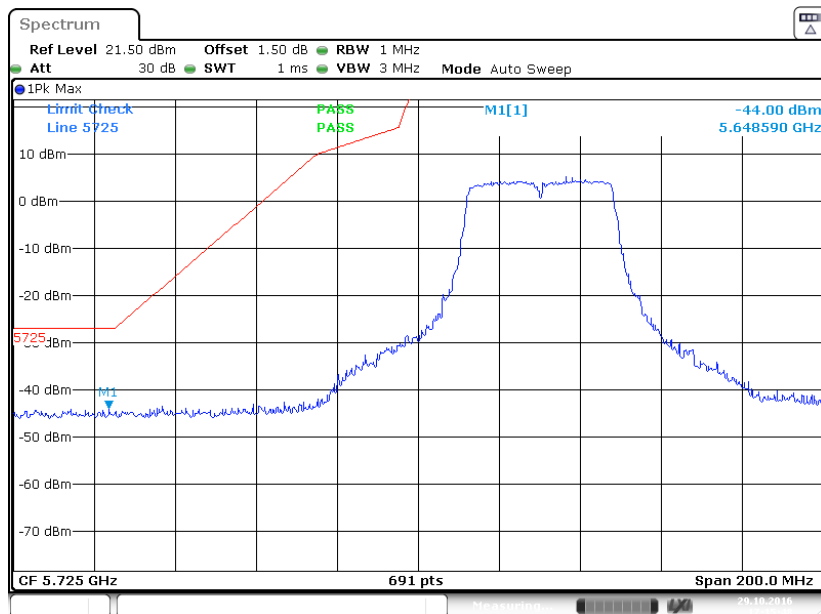

802.11ac80 Chain1 Band Edge, Left Side

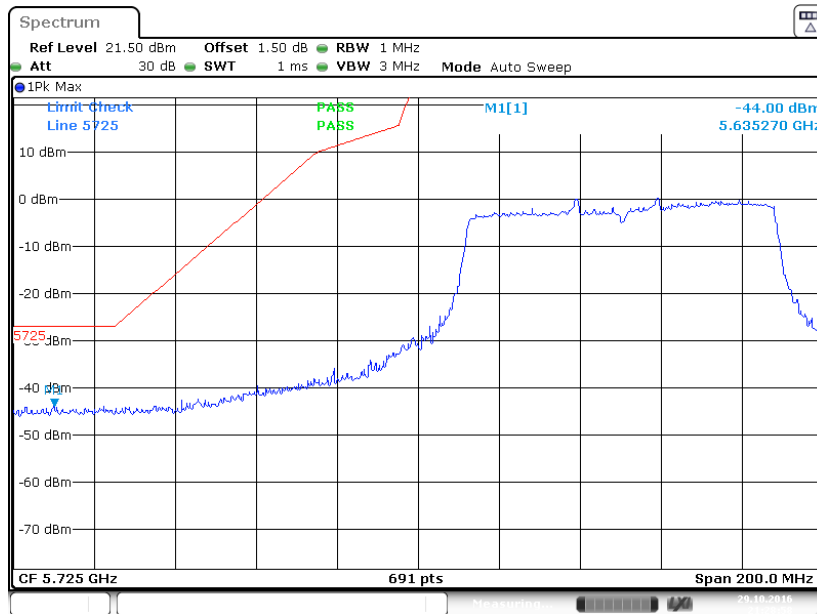

802.11ac80 Chain1 Band Edge, Right Side

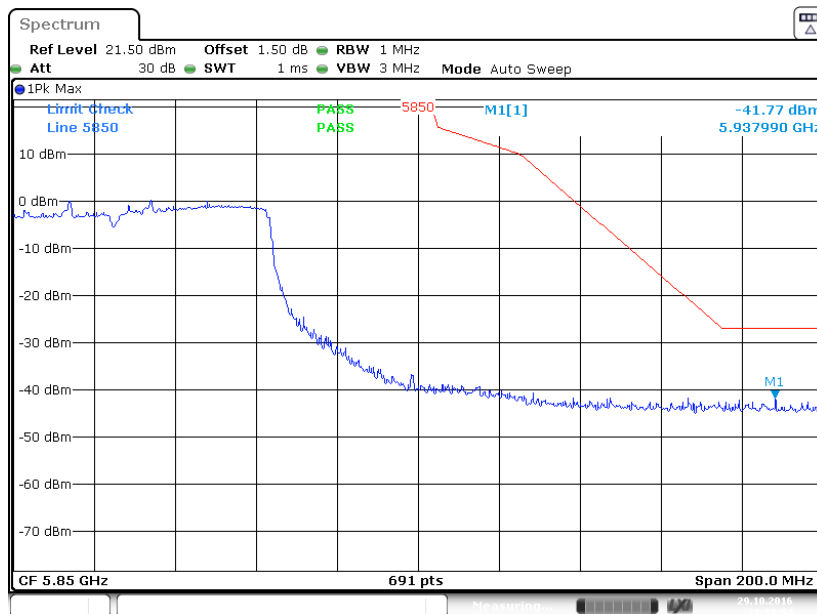

FCC §15.407(a) & §15.407(e)–EMISSION BANDWIDTH

Applicable Standard

The maximum power spectral density is measured as a conducted emission by direct connection of a calibrated test instrument to the equipment under test. If the device cannot be connected directly, alternative techniques acceptable to the Commission may be used. Measurements in the 5.725-5.85 GHz band are made over a reference bandwidth of 500 kHz or the 26 dB emission bandwidth of the device, whichever is less. Measurements in the 5.15-5.25 GHz is made over a bandwidth of 1 MHz or the 26 dB emission bandwidth of the device, whichever is less. A narrower resolution bandwidth can be used, provided that the measured power is integrated over the full reference bandwidth.

For the 5.25–5.35 GHz and 5.47–5.725 GHz bands, the maximum conducted output power over the frequency bands of operation shall not exceed the lesser of 250 mW or 11 dBm + 10 log B, where B is the 26 dB emission bandwidth in megahertz. In addition, the peak power spectral density shall not exceed 11 dBm in any 1 megahertz band. If transmitting antennas of directional gain greater than 6 dBi are used, both the maximum conducted output power and the peak power spectral density shall be reduced by the amount in dB that the directional gain of the antenna exceeds 6 dBi.

Within the 5.725-5.85 GHz band, the minimum 6 dB bandwidth of U-NII devices shall be at least 500 kHz.

Test Equipment List and Details

Manufacturer	Description	Model	Serial Number	Calibration Date	Calibration Due Date
Rohde & Schwarz	SIGNALANALYZER	FSV40	101116	2016-07-04	2017-07-03
BACL	RF cable	KS-LAB-012	KS-LAB-012	2015-12-16	2016-12-15

* **Statement of Traceability:** Bay Area Compliance Laboratories Corp. (Kunshan) attests that all calibrations have been performed, traceable to National Primary Standards and International System of Units (SI).

Test Procedure

1. Emission Bandwidth (EBW)

- Set RBW = approximately 1% of the emission bandwidth.
- Set the VBW > RBW.
- Detector = Peak.
- Trace mode = max hold.
- Measure the maximum width of the emission that is 26 dB down from the maximum of the emission. Compare this with the RBW setting of the analyzer. Readjust RBW and repeat measurement as needed until the RBW/EBW ratio is approximately 1%.

2. Minimum Emission Bandwidth for the band 5.725-5.85 GHz

Section 15.407(e) specifies the minimum 6 dB emission bandwidth of at least 500 KHz for the band 5.725-5.85 GHz. The following procedure shall be used for measuring this bandwidth:

- Set RBW = 100 kHz.
- Set the video bandwidth (VBW) $\geq 3 \times$ RBW.
- Detector = Peak.
- Trace mode = max hold.
- Sweep = auto couple.
- Allow the trace to stabilize.

g) Measure the maximum width of the emission that is constrained by the frequencies associated with the two outermost amplitude points (upper and lower frequencies) that are attenuated by 6 dB relative to the maximum level measured in the fundamental emission.

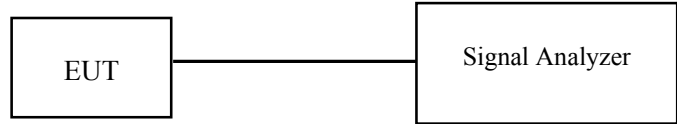

Test Data

Environmental Conditions

Temperature:	23.5 °C
Relative Humidity:	60 %
ATM Pressure:	99.9 kPa

The testing was performed by Edison Hu on 2016-10-21 to 2016-11-06.

Test Result: Pass.

Please refer to the following tables and plots.

Test Mode: Transmitting (Test only performed at Chain 0)

Test mode	Channel	Frequency (MHz)	6dB Bandwidth (MHz)	Limit (MHz)
802.11a	Low	5745	16.38	≥0.5
	Middle	5785	16.38	≥0.5
	High	5825	16.38	≥0.5
802.11n ht20	Low	5745	17.48	≥0.5
	Middle	5785	17.42	≥0.5
	High	5825	17.60	≥0.5
802.11n ht40	Low	5755	36.35	≥0.5
	High	5795	36.35	≥0.5
802.11ac80	Middle	5775	75.48	≥0.5

802.11a mode, Chain 0: 6 Bandwidth-5745MHz

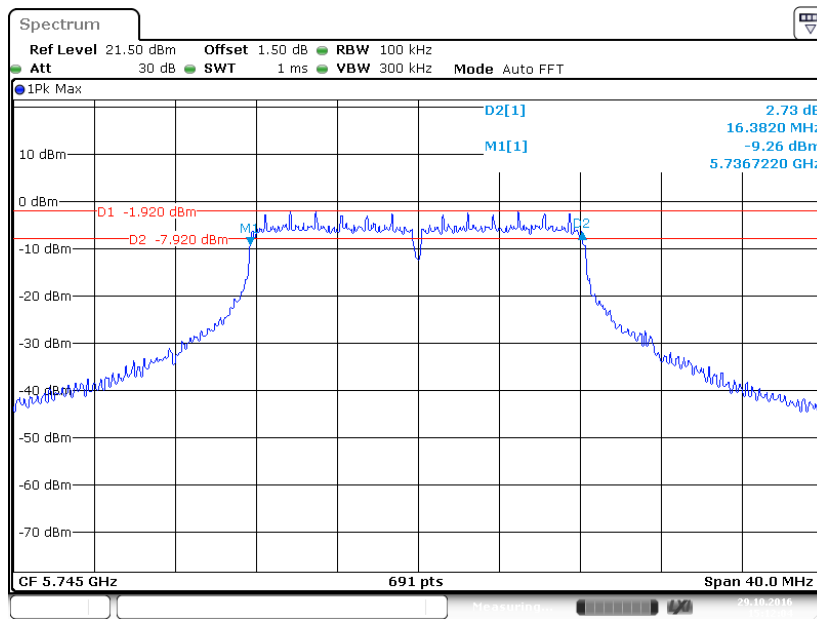

Date: 29.OCT.2016 15:12:04

802.11a mode, Chain 0: 6 Bandwidth-5785MHz

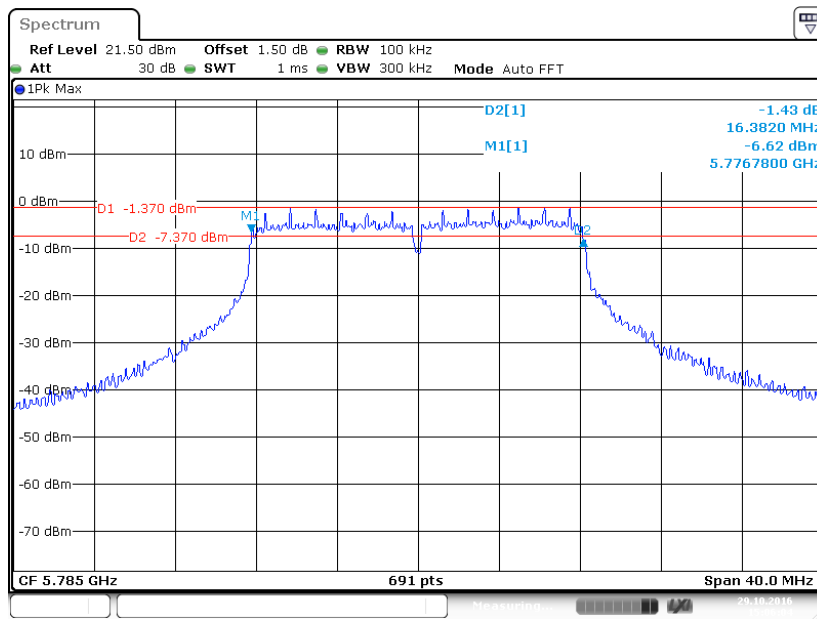

Date: 29.OCT.2016 15:06:05

802.11a mode, Chain 0: 6 Bandwidth-5825MHz

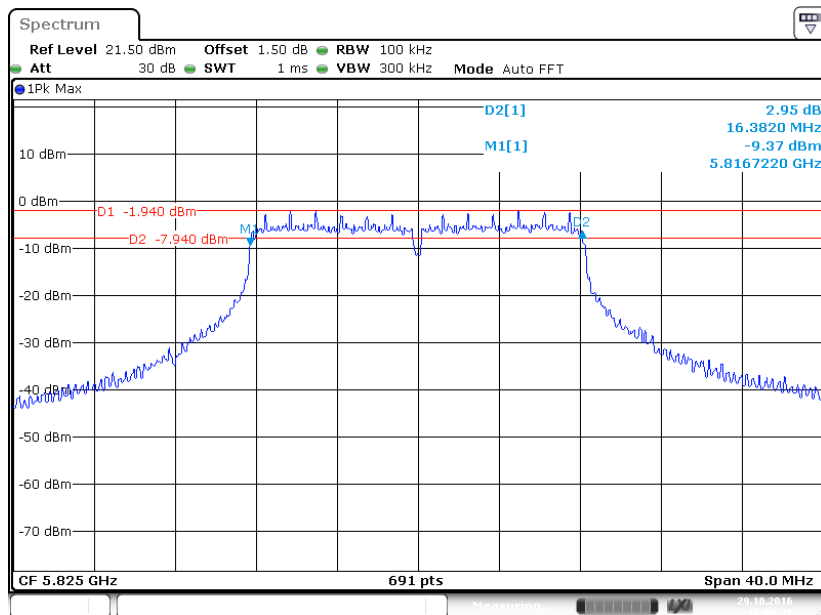

802.11n ht20 mode, Chain 0: 6 Bandwidth-5745MHz

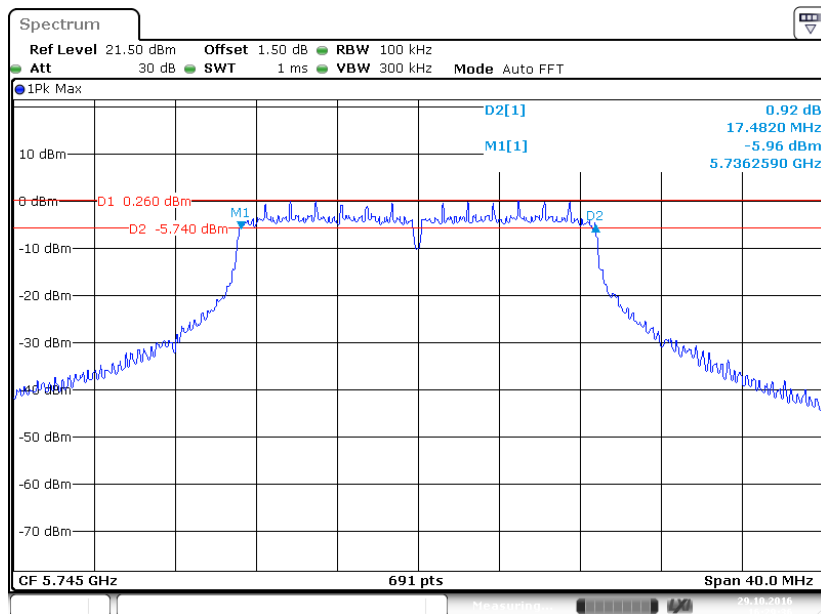

802.11n ht20 mode, Chain 0: 6 Bandwidth-5785MHz

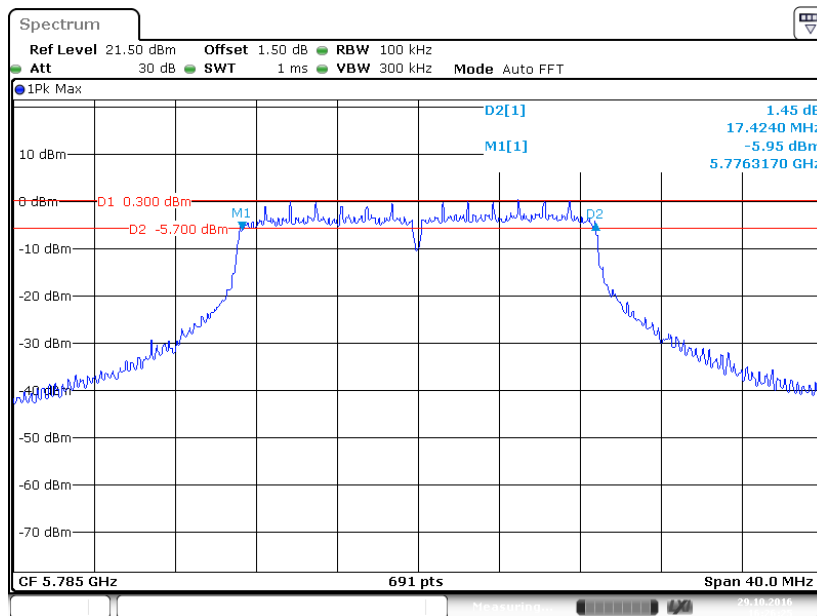

802.11n ht20 mode, Chain 0: 6 Bandwidth-5825MHz

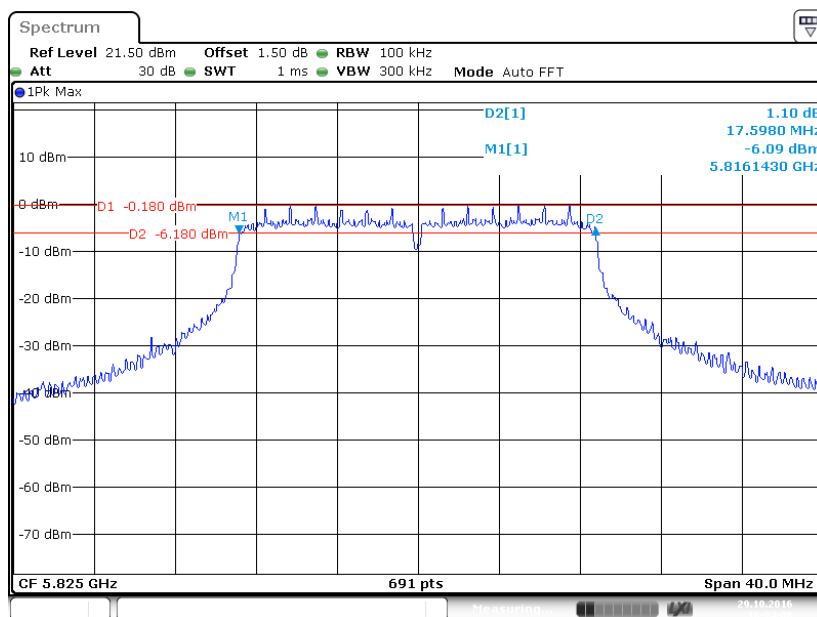

802.11n ht40 mode, Chain 0: 6 Bandwidth-5755MHz

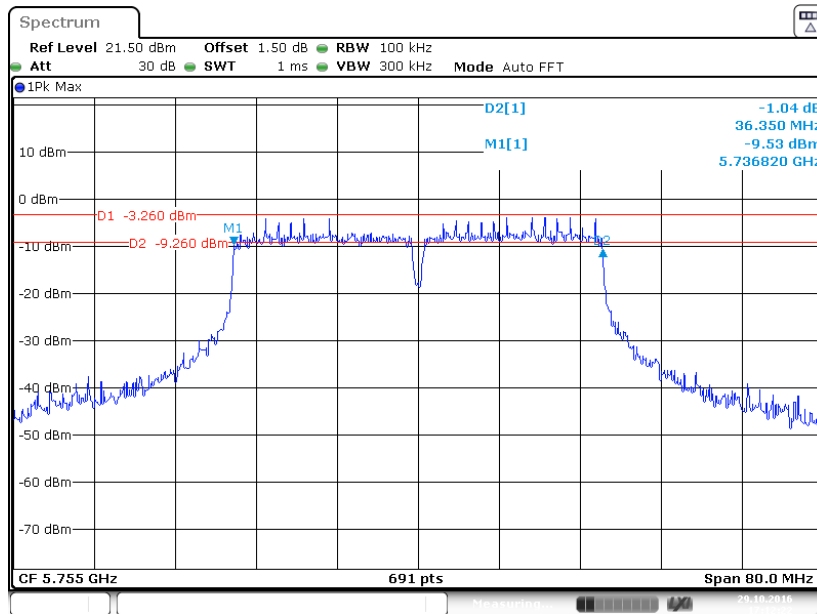

Date: 29.OCT.2016 17:12:22

802.11n ht40 mode, Chain 0: 6 Bandwidth-5795MHz

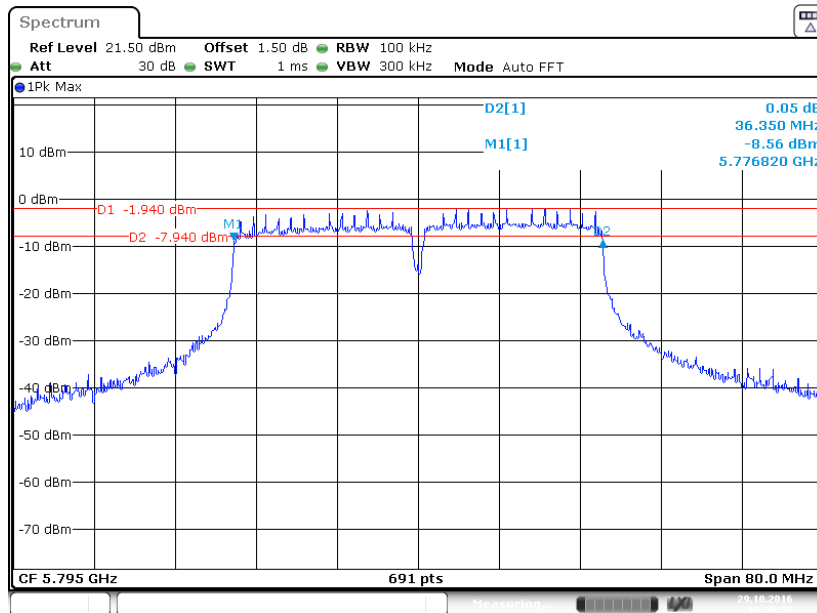

Date: 29.OCT.2016 17:09:58

802.11ac80 mode, Chain 0: 6 Bandwidth-5775MHz

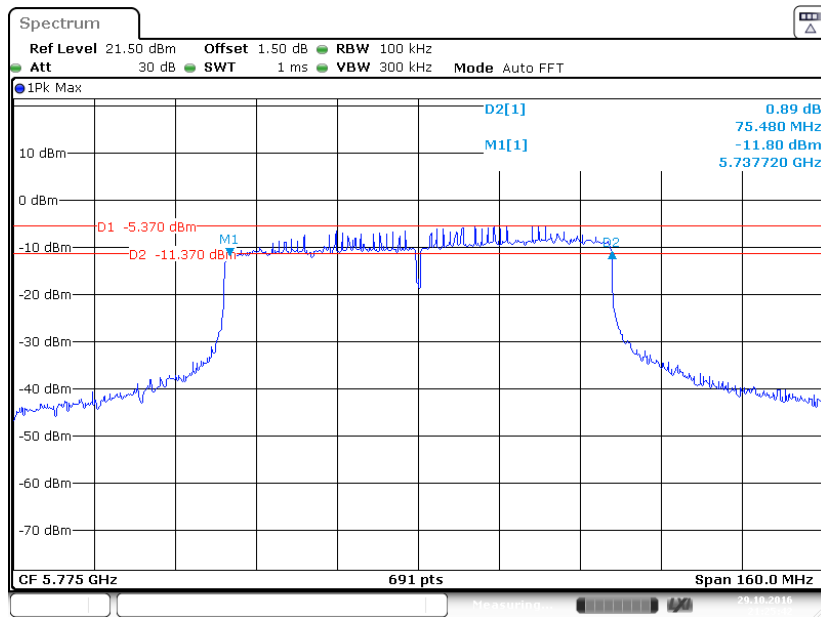

Date: 29.OCT.2016 21:25:43

FCC §15.407(a) (1) – CONDUCTED TRANSMITTER OUTPUT POWER

Applicable Standard

For an indoor access point operating in the band 5.15-5.25 GHz, the maximum conducted output power over the frequency band of operation shall not exceed 1 W provided the maximum antenna gain does not exceed 6 dBi. In addition, the maximum power spectral density shall not exceed 17 dBm in any 1 megahertz band. If transmitting antennas of directional gain greater than 6 dBi are used, both the maximum conducted output power and the maximum power spectral density shall be reduced by the amount in dB that the directional gain of the antenna exceeds 6 dBi.

For the 5.25-5.35 GHz and 5.47-5.725 GHz bands, the maximum conducted output power over the frequency bands of operation shall not exceed the lesser of 250 mW or 11 dBm + 10 log B, where B is the 26 dB emission bandwidth in megahertz.

For the band 5.725-5.85 GHz, the maximum conducted output power over the frequency band of operation shall not exceed 1 W. In addition, the maximum power spectral density shall not exceed 30 dBm in any 500-kHz band. If transmitting antennas of directional gain greater than 6 dBi are used, both the maximum conducted output power and the maximum power spectral density shall be reduced by the amount in dB that the directional gain of the antenna exceeds 6 dBi. However, fixed point-to-point U-NII devices operating in this band may employ transmitting antennas with directional gain greater than 6 dBi without any corresponding reduction in transmitter conducted power. Fixed, point-to-point operations exclude the use of point-to-multipoint systems, omnidirectional applications, and multiple collocated transmitters transmitting the same information. The operator of the U-NII device, or if the equipment is professionally installed, the installer, is responsible for ensuring that systems employing high gain directional antennas are used exclusively for fixed, point-to-point operations.

Test Equipment List and Details

Manufacturer	Description	Model	Serial Number	Calibration Date	Calibration Due Date
Rohde & Schwarz	OSP120 BASE UNIT	OSP120	101247	2016-07-04	2017-07-03
Rohde & Schwarz	Power Sensor	NRP-Z91	200014	2015-08-01	2017-07-31
BACL	RF cable	KS-LAB-012	KS-LAB-012	2015-12-16	2016-12-15

* **Statement of Traceability:** Bay Area Compliance Laboratories Corp. (Kunshan) attests that all calibrations have been performed, traceable to National Primary Standards and International System of Units (SI).

Test Procedure

1. Place the EUT on a bench and set it in transmitting mode.
2. Remove the antenna from the EUT and then connect a low loss RF cable from the antenna port to one test equipment.
3. Add a correction factor to the display.

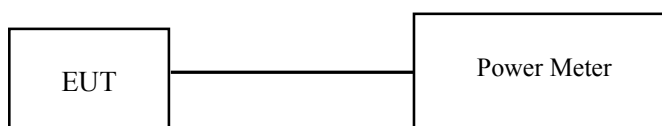

Test Data**Environmental Conditions**

Temperature:	23.5 °C
Relative Humidity:	60 %
ATM Pressure:	99.9 kPa

The testing was performed by Edison Hu on 2016-11-10.

Test Mode: Transmitting

SISO mode

Test mode	Channel	Frequency (MHz)	Maximum Conducted Output Power (dBm)		Limit (dBm)	Result
			Chain0	Chain1		
802.11a	Low	5745	16.60	16.64	30	PASS
	Middle	5785	17.17	17.02	30	PASS
	High	5825	16.89	16.83	30	PASS
802.11n ht20	Low	5745	15.96	15.94	30	PASS
	Middle	5785	16.08	16.21	30	PASS
	High	5825	15.65	15.79	30	PASS
802.11n ht40	Low	5755	15.74	15.63	30	PASS
	High	5795	15.89	16.22	30	PASS
802.11ac80	Middle	5775	14.51	14.57	30	PASS

Note:

The EUT has two PCB antenna arrangement for wifi, the antenna gain are 5.3dBi and 5.2 dBi@5GHz band.

2*2 Non-beamforming mode

Test mode	Channel	Frequency (MHz)	Maximum Conducted Output Power (dBm)			Limit (dBm)	Result
			Chain0	Chain1	Total		
802.11a	Low	5745	16.25	16.54	19.41	30	PASS
	Middle	5785	16.78	16.84	19.82	30	PASS
	High	5825	16.55	16.44	19.51	30	PASS
802.11n ht20	Low	5745	16.01	16.12	19.08	30	PASS
	Middle	5785	16.13	16.36	19.26	30	PASS
	High	5825	15.78	15.89	18.85	30	PASS
802.11n ht40	Low	5755	15.83	15.78	18.82	30	PASS
	High	5795	15.98	16.46	19.24	30	PASS
802.11ac80	Middle	5775	14.45	14.46	17.46	30	PASS

Note:

The EUT has two PCB antenna arrangement for wifi, the antenna gain are 5.3dBi and 5.2 dBi@5GHz band.

Cyclic Delay Diversity (CDD) was employed by 802.11 MIMO Non-beamforming mode, per C63.10-2013 clause 14.4.3.2.5 a and b, for power measurements on IEEE 802.11 devices:

$$\text{Directional gain} = G_{ant} + \text{array gain}$$

$$\text{Array Gain} = 0 \text{ dB (i.e., no array gain) for } N_{ANT} \leq 4;$$

2*2 Beamforming mode

Test mode	Channel	Frequency (MHz)	Maximum Conducted Output Power (dBm)			Limit (dBm)	Result
			Chain0	Chain1	Total		
802.11n ht20	Low	5745	15.96	15.94	18.96	27.74	PASS
	Middle	5785	16.08	16.21	19.16	27.74	PASS
	High	5825	15.65	15.79	18.73	27.74	PASS
802.11n ht40	Low	5755	15.74	15.63	18.70	27.74	PASS
	High	5795	15.89	16.22	19.07	27.74	PASS
802.11ac80	Middle	5775	14.34	14.38	17.37	27.74	PASS

Note:

The EUT has two PCB antenna arrangement for wifi, the antenna gain are 5.3dBi and 5.2 dBi@5GHz band. For beamforming mode, C63.10-2013 clause 14.4.3.2.3, power measurements on IEEE 802.11 devices:

a) If transmit signals are correlated, then:

$$\text{Directional gain} = 10 \log \left[\frac{\left(10^{G_1/20} + 10^{G_2/20} + \dots + 10^{G_N/20} \right)^2}{N_{\text{ANT}}} \right] \text{ dBi}$$

$$\text{Directional Gain} = 10 * \log \left[\frac{(10^{5.3/20} + 10^{5.2/20})^2}{2} \right] = 8.26 \text{ dBi}$$

Power limit was reduced by 2.26dBi

FCC §15.407(a) - POWER SPECTRAL DENSITY

Applicable Standard

According to § 15.407(a)(1)

(ii) For an indoor access point operating in the band 5.15-5.25 GHz, the maximum conducted output power over the frequency band of operation shall not exceed 1 W provided the maximum antenna gain does not exceed 6 dBi. In addition, the maximum power spectral density shall not exceed 17 dBm in any 1 megahertz band. If transmitting antennas of directional gain greater than 6 dBi are used, both the maximum conducted output power and the maximum power spectral density shall be reduced by the amount in dB that the directional gain of the antenna exceeds 6 dBi.

(iii) For fixed point-to-point access points operating in the band 5.15-5.25 GHz, the maximum conducted output power over the frequency band of operation shall not exceed 1 W. In addition, the maximum power spectral density shall not exceed 17 dBm in any 1 megahertz band. Fixed point-to-point U-NII devices may employ antennas with directional gain up to 23 dBi without any corresponding reduction in the maximum conducted output power or maximum power spectral density. For fixed point-to-point transmitters that employ a directional antenna gain greater than 23 dBi, a 1 dB reduction in maximum conducted output power and maximum power spectral density is required for each 1 dB of antenna gain in excess of 23 dBi. Fixed, point-to-point operations exclude the use of point-to-multipoint systems, omnidirectional applications, and multiple collocated transmitters transmitting the same information. The operator of the U-NII device, or if the equipment is professionally installed, the installer, is responsible for ensuring that systems employing high gain directional antennas are used exclusively for fixed, point-to-point operations.

According to § 15.407(a)(2)

For the 5.25-5.35 GHz and 5.47-5.725 GHz bands, the maximum conducted output power over the frequency bands of operation shall not exceed the lesser of 250 mW or $11 \text{ dBm} + 10 \log B$, where B is the 26 dB emission bandwidth in megahertz. In addition, the maximum power spectral density shall not exceed 11 dBm in any 1 megahertz band. If transmitting antennas of directional gain greater than 6 dBi are used, both the maximum conducted output power and the maximum power spectral density shall be reduced by the amount in dB that the directional gain of the antenna exceeds 6 dBi.

According to § 15.407(a)(3)

For the band 5.725-5.85 GHz, the maximum conducted output power over the frequency band of operation shall not exceed 1 W. In addition, the maximum power spectral density shall not exceed 30 dBm in any 500-kHz band. If transmitting antennas of directional gain greater than 6 dBi are used, both the maximum conducted output power and the maximum power spectral density shall be reduced by the amount in dB that the directional gain of the antenna exceeds 6 dBi. However, fixed point-to-point U-NII devices operating in this band may employ transmitting antennas with directional gain greater than 6 dBi without any corresponding reduction in transmitter conducted power. Fixed, point-to-point operations exclude the use of point-to-multipoint systems, omnidirectional applications, and multiple collocated transmitters transmitting the same information. The operator of the U-NII device, or if the equipment is professionally installed, the installer, is responsible for ensuring that systems employing high gain directional antennas are used exclusively for fixed, point-to-point operations.

Test Procedure

The measurements are based on FCC KDB 789033 D02 General UNII Test Procedures New Rules v01: Guidelines for Compliance Testing of Unlicensed National Information Infrastructure (U-NII) Devices section F: Maximum power spectral density (PPSD)

Test Equipment List and Details

Manufacturer	Description	Model	Serial Number	Calibration Date	Calibration Due Date
Rohde & Schwarz	SIGNALANALYZER	FSV40	101116	2016-07-04	2017-07-03
BACL	RF cable	KS-LAB-012	KS-LAB-012	2015-12-16	2016-12-15

* **Statement of Traceability:** Bay Area Compliance Laboratories Corp. (Kunshan) attests that all calibrations have been performed, traceable to National Primary Standards and International System of Units (SI).

Test Data**Environmental Conditions**

Temperature:	23.5 °C
Relative Humidity:	60 %
ATM Pressure:	99.9 kPa

The testing was performed by Edison Hu on 2016-10-21 to 2016-10-29.

Test Mode: Transmitting(SISO mode was tested)

Test Result: Pass. SISO mode was the worst mode since maximum output power per chain, so combined two chains meet the requirements also.

Mode	Channel	Frequency MHz	PSD (dBm/500kHz)			Limit (dBm/500kHz)	Result
			Chain0	Chain1	Total		
802.11a	Low	5745	-1.47	-1.50	1.53	27.74	PASS
	Middle	5785	-0.39	-0.28	2.68	27.74	PASS
	High	5825	-1.08	-1.15	1.90	27.74	PASS
802.11n20	Low	5745	3.41	3.56	6.50	27.74	PASS
	Middle	5785	3.81	3.86	6.85	27.74	PASS
	High	5825	3.40	3.39	6.41	27.74	PASS
802.11n40	Low	5755	0.04	0.42	3.24	27.74	PASS
	High	5795	1.95	1.73	4.85	27.74	PASS
802.11ac80	Middle	5775	-3.10	-3.38	0.23	27.74	PASS

Note:

The EUT has two PCB antenna arrangement for wifi, the antenna gain are 5.3dBi and 5.2 dBi@5GHz band. The strict limit was the used for compliance evaluation.

C63.10-2013 clause 14.4.3.2.3, PSD measurements on IEEE 802.11 devices:

a) If transmit signals are correlated, then:

$$\text{Directional gain} = 10 \log \left[\frac{\left(10^{G_1/20} + 10^{G_2/20} + \dots + 10^{G_N/20} \right)^2}{N_{\text{ANT}}} \right] \text{ dBi}$$

$$\text{Directional Gain} = 10 * \log \left[\frac{\left(10^{5.3/20} + 10^{5.2/20} \right)^2}{2} \right] = 8.26 \text{ dBi}$$

PSD limit was reduced by 2.26dBi

802.11a mode, Chain 0: Power spectral density-5745MHz

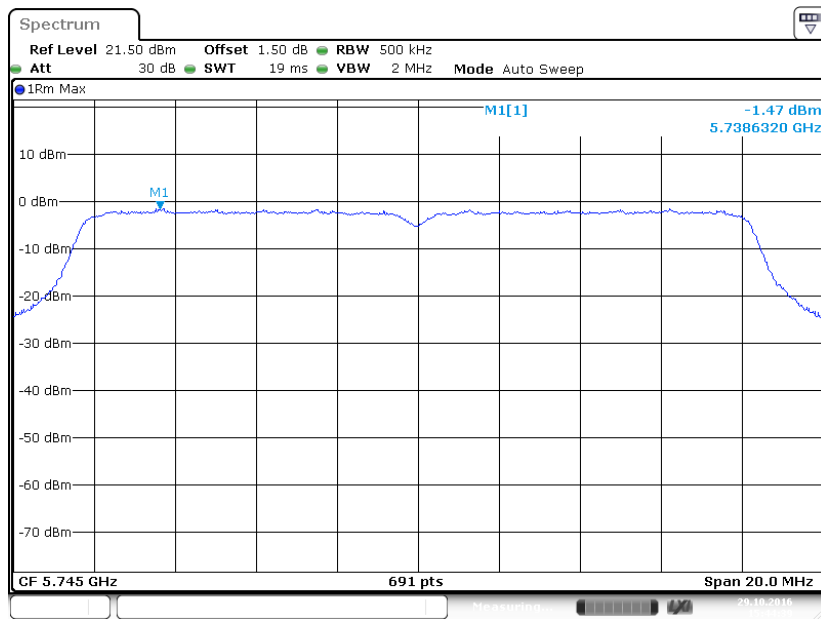

802.11a mode, Chain 0: Power spectral density-5785MHz

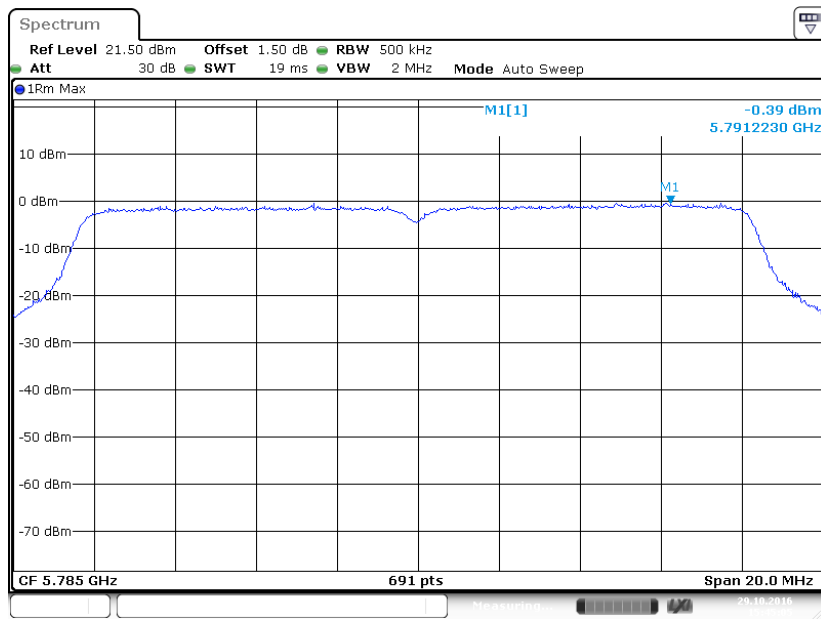

802.11a mode, Chain 0: Power spectral density-5825MHz

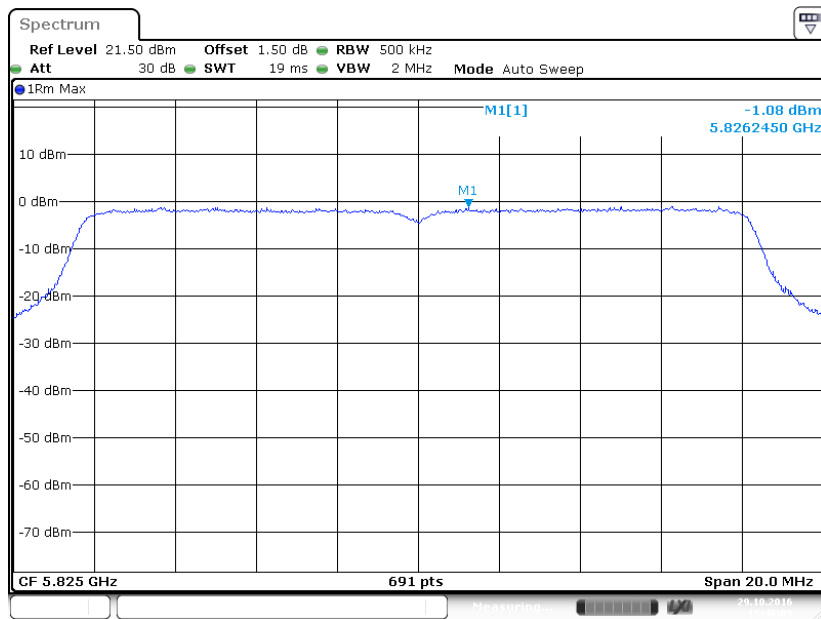

802.11n ht20 mode, Chain 0: Power spectral density-5745MHz

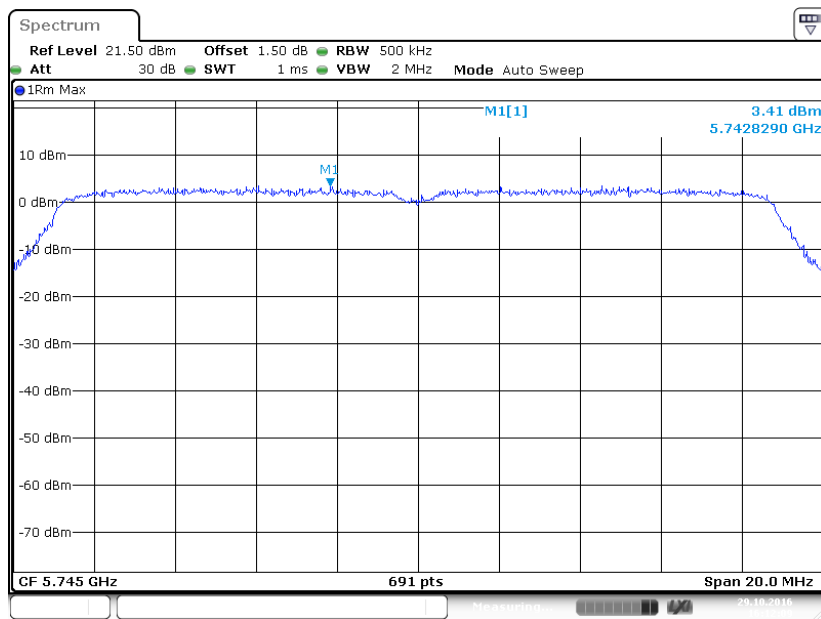

802.11n ht20 mode, Chain 0: Power spectral density-5785MHz

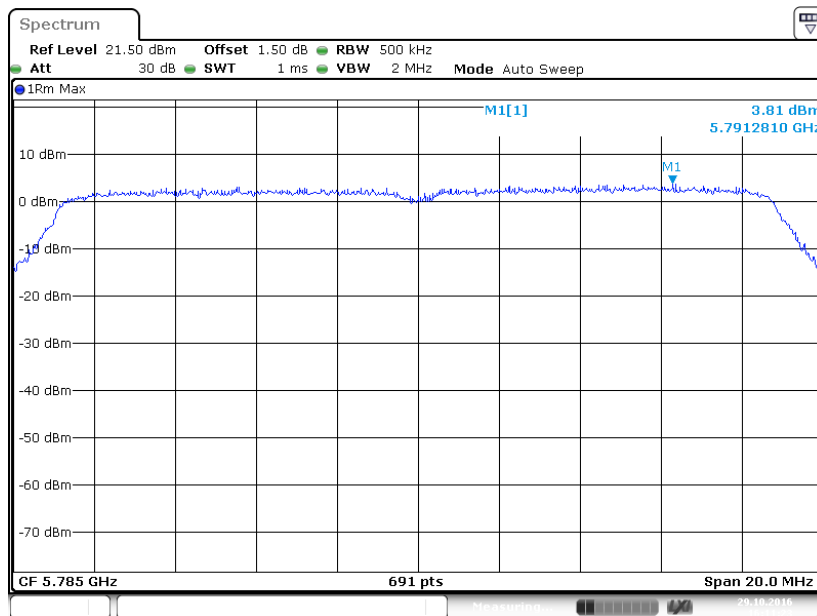

802.11n ht20 mode, Chain 0: Power spectral density-5825MHz

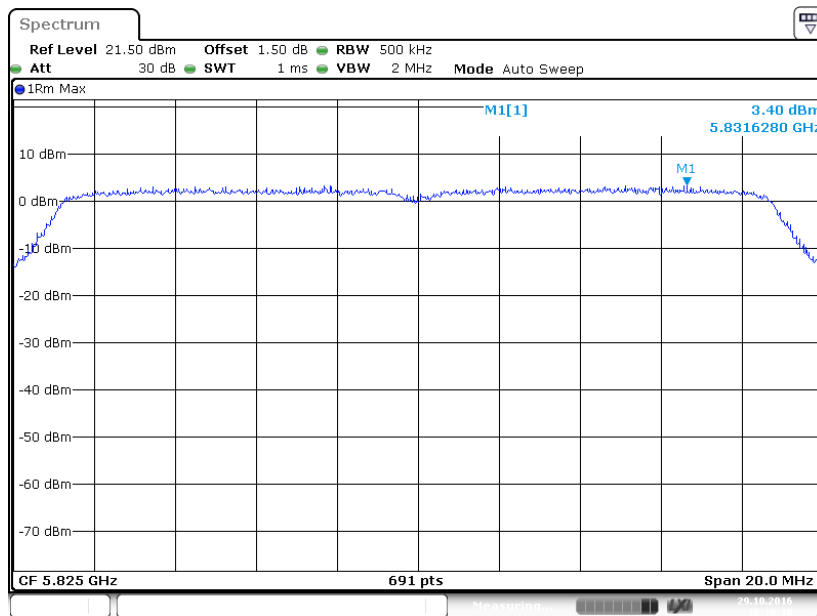

802.11n ht40 mode, Chain 0: Power spectral density-5755MHz

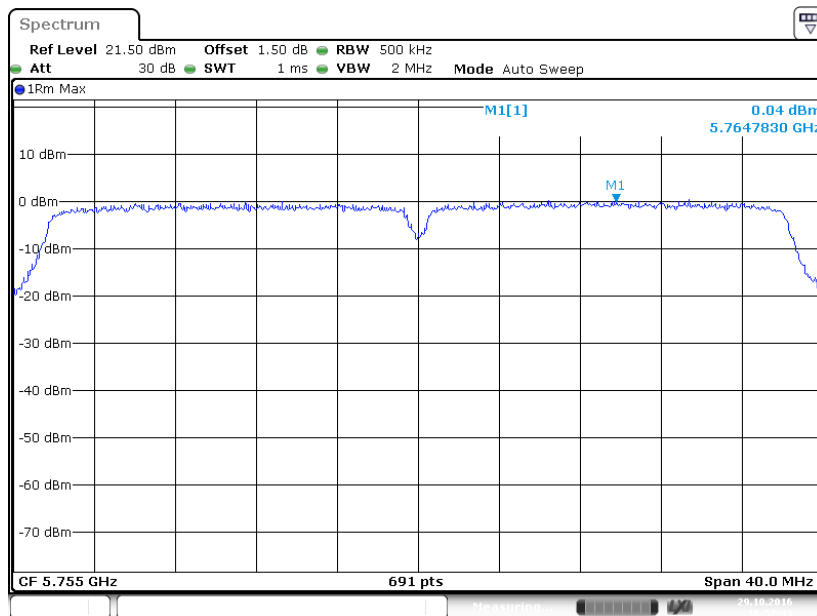

802.11n ht40 mode, Chain 0: Power spectral density-5795MHz

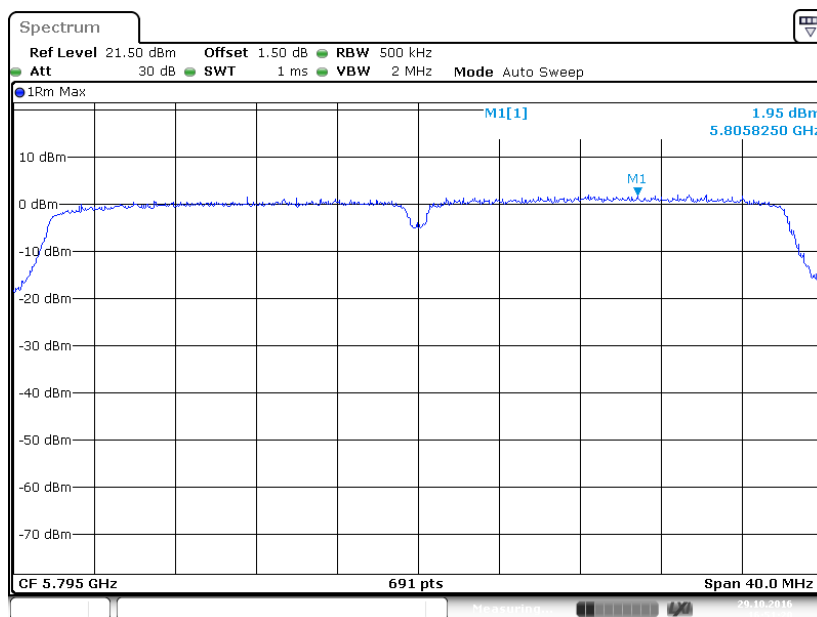

802.11ac80 mode, Chain 0: Power spectral density-5775MHz

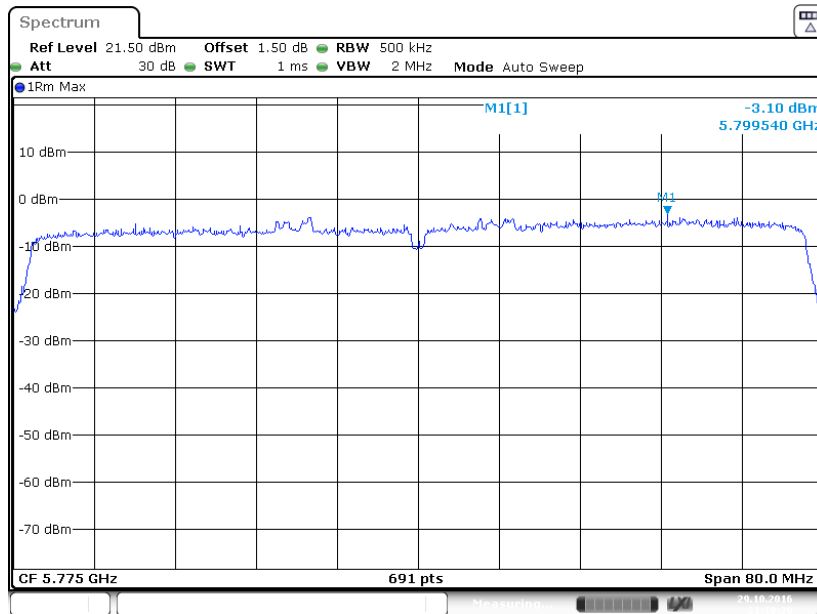

Date: 29.OCT.2016 21:18:20

802.11a mode, Chain 1: Power spectral density-5745MHz

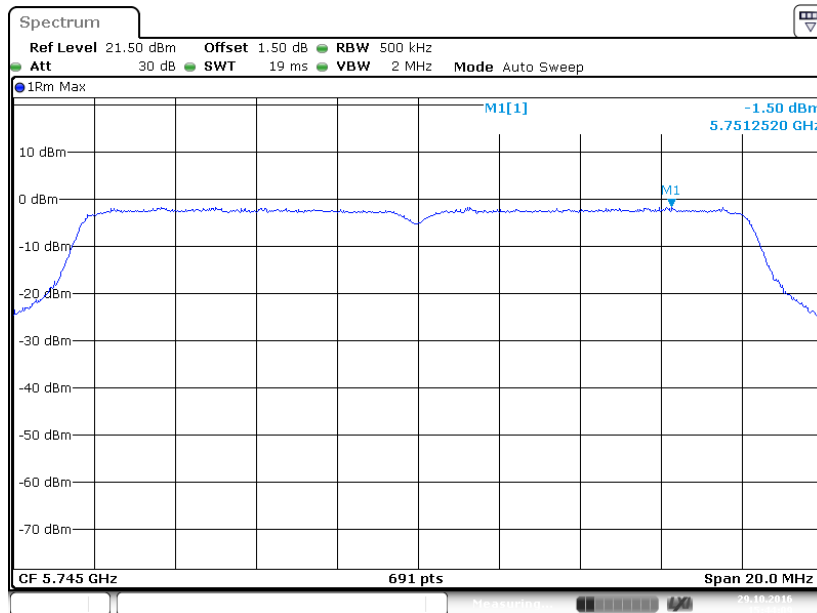

Date: 29.OCT.2016 15:44:09

802.11a mode, Chain 1: Power spectral density-5785MHz

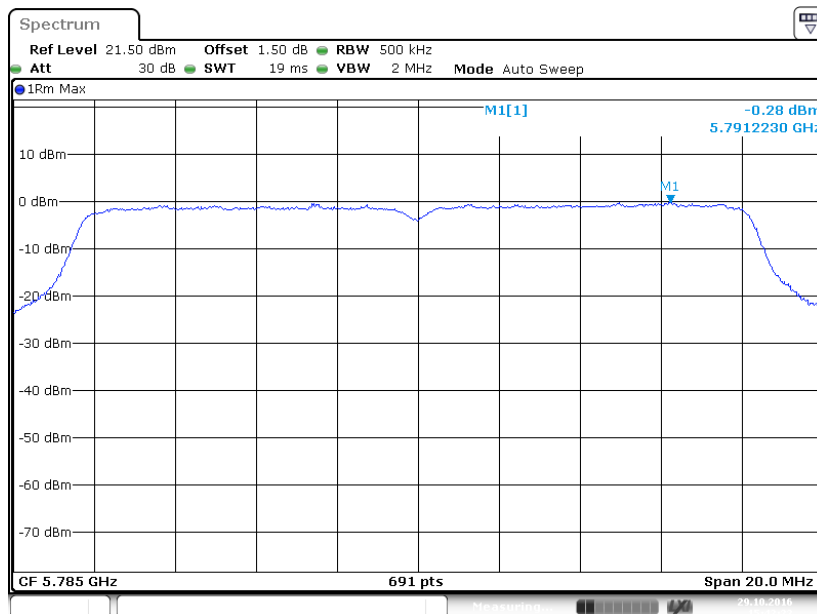

Date: 29.OCT.2016 15:42:22

802.11a mode, Chain 1: Power spectral density-5825MHz

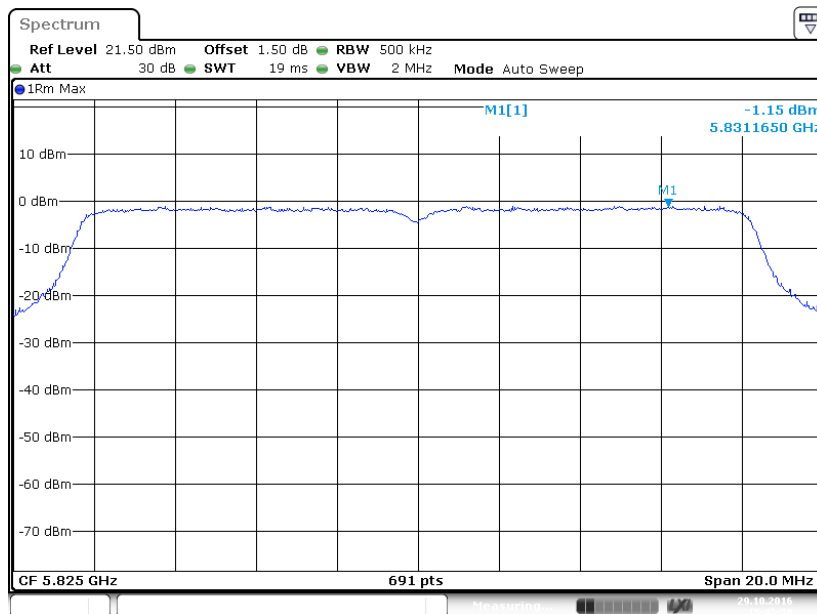

Date: 29.OCT.2016 15:42:50

802.11n ht20 mode, Chain 1: Power spectral density-5745MHz

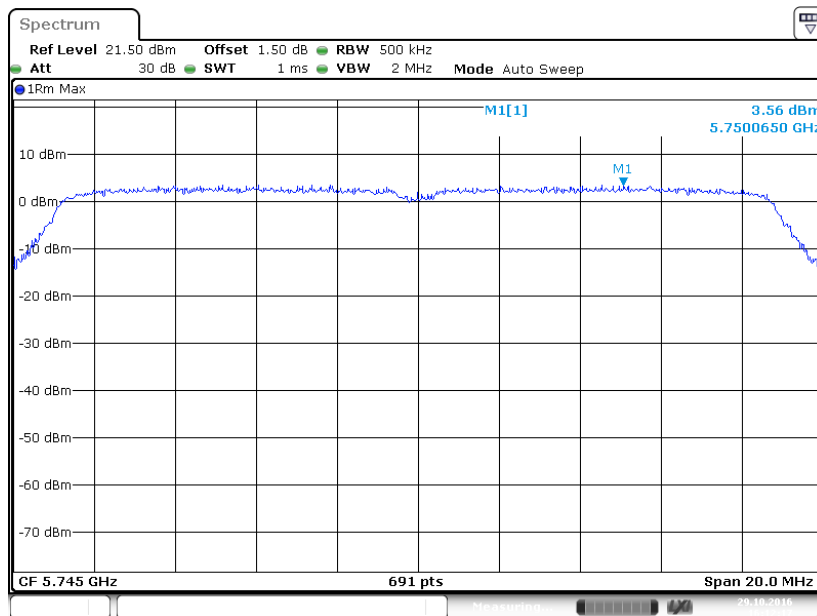

802.11n ht20 mode, Chain 1: Power spectral density-5785MHz

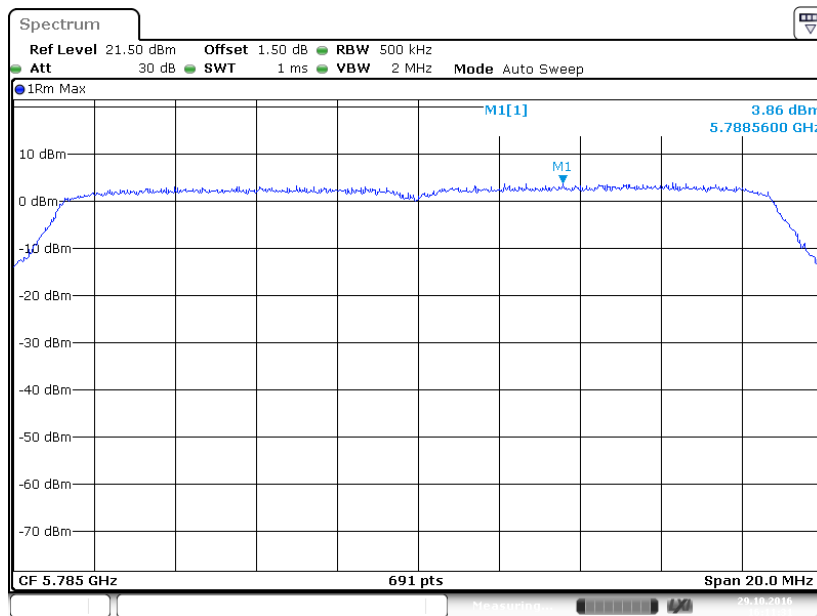

802.11n ht20 mode, Chain 1: Power spectral density-5825MHz

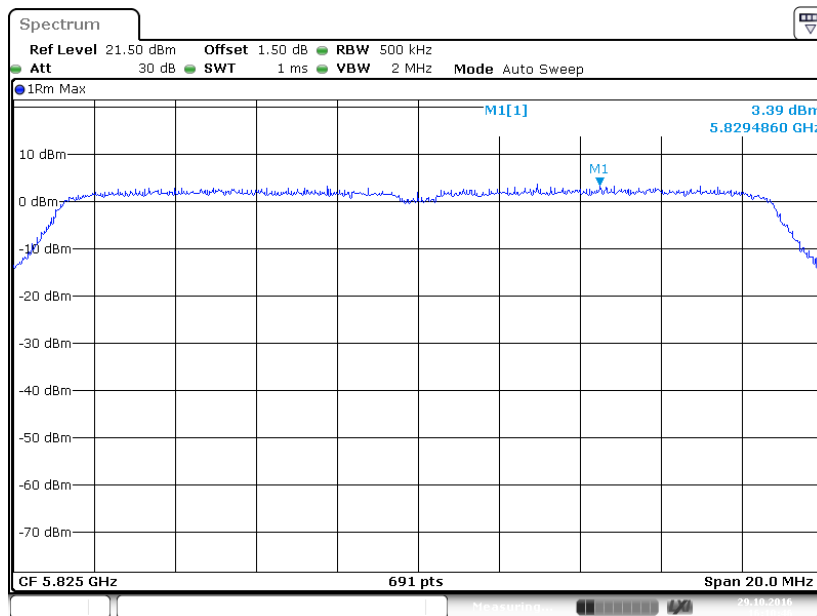

802.11n ht40 mode, Chain 1: Power spectral density-5755MHz

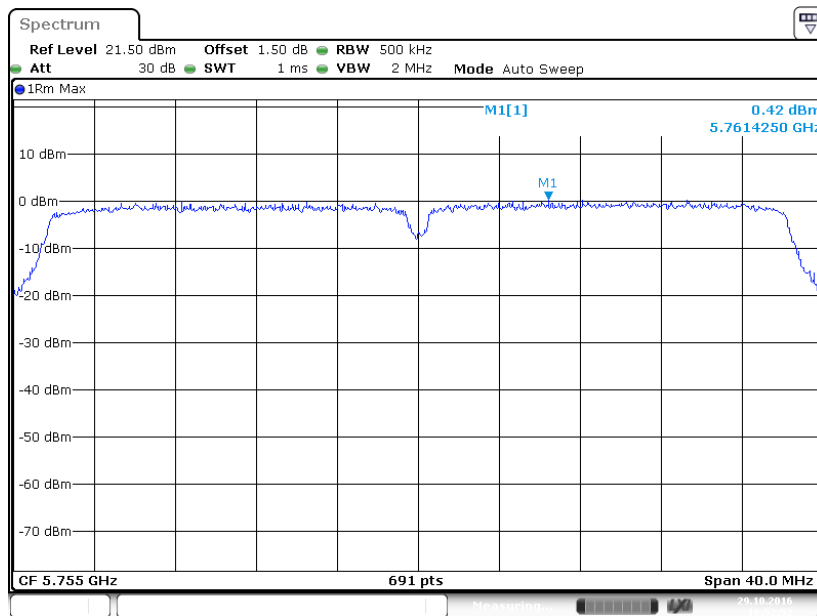

802.11n ht40 mode, Chain 1: Power spectral density-5795MHz

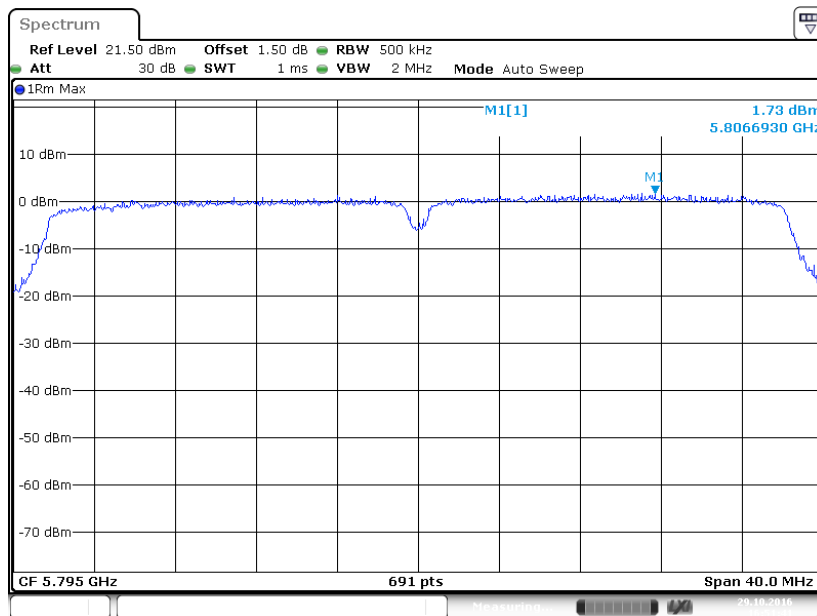

802.11ac80 mode, Chain 1: Power spectral density-5775MHz

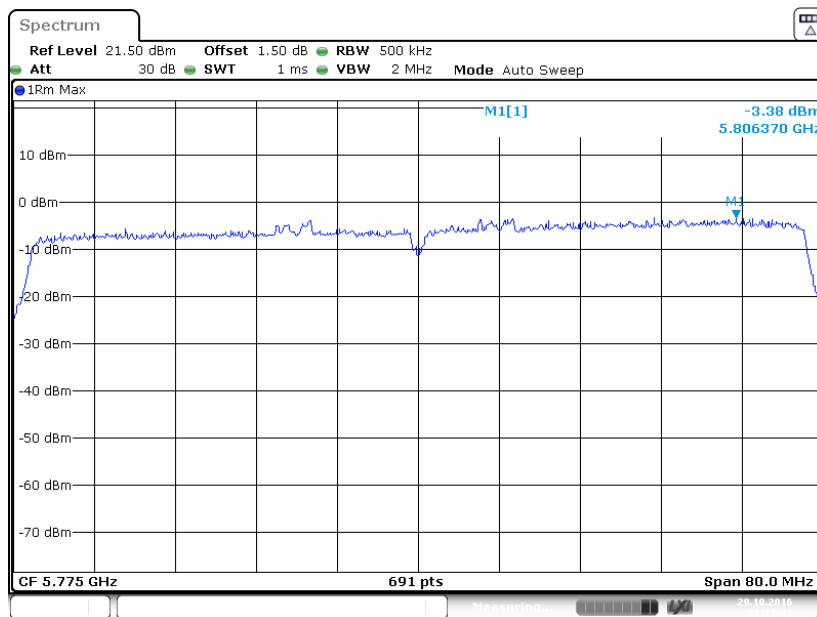

**** END OF REPORT ****