



RF TEST REPORT

Applicant Huawei Technologies Co., Ltd.
FCC ID QISANE-LX2J
Product Smart Phone
Model ANE-LX2J, HWV32
Report No. R1803H0031-R1
Issue Date May 7, 2018

TA Technology (Shanghai) Co., Ltd. tested the above equipment in accordance with the requirements in **FCC CFR47 Part 15E (2017)**. The test results show that the equipment tested is capable of demonstrating compliance with the requirements as documented in this report.

Performed by: Xianqing Li

Approved by: Kai Xu

TA Technology (Shanghai) Co., Ltd.

No.145, Jintang Rd, Tangzhen Industry Park, Pudong Shanghai, China

TEL: +86-021-50791141/2/3

FAX: +86-021-50791141/2/3-8000



TABLE OF CONTENT

1. Test Laboratory	4
1.1. Notes of the test report.....	4
1.2. Test facility	4
1.3. Testing Location.....	5
2. General Description of Equipment under Test.....	6
3. Applied Standards	9
4. Test Configuration	10
5. Test Case Results	12
5.1. Unwanted Emission	12
6. Main Test Instruments.....	219



Summary of measurement results

Number	Summary of measurements of results	Clause in FCC rules	Verdict
1	Unwanted Emissions	15.407(b)	PASS
Date of Testing: March 16, 2018 ~ March 22, 2018			



1. Test Laboratory

1.1. Notes of the test report

This report shall not be reproduced in full or partial, without the written approval of **TA technology (shanghai) co., Ltd.** The results documented in this report apply only to the tested sample, under the conditions and modes of operation as described herein. Measurement Uncertainties were not taken into account and are published for informational purposes only. This report is written to support regulatory compliance of the applicable standards stated above.

1.2. Test facility

CNAS (accreditation number: L2264)

TA Technology (Shanghai) Co., Ltd. has obtained the accreditation of China National Accreditation Service for Conformity Assessment (CNAS).

FCC (Designation number: CN1179, Test Firm Registration Number: 446626)

TA Technology (Shanghai) Co., Ltd. has been listed on the US Federal Communications Commission list of test facilities recognized to perform electromagnetic emissions measurements.

IC (recognition number is 8510A)

TA Technology (Shanghai) Co., Ltd. has been listed by industry Canada to perform electromagnetic emission measurement.

VCCI (recognition number is C-4595, T-2154, R-4113, G-10766)

TA Technology (Shanghai) Co., Ltd. has been listed by industry Japan to perform electromagnetic emission measurement.

A2LA (Certificate Number: 3857.01)

TA Technology (Shanghai) Co., Ltd. has been listed by American Association for Laboratory Accreditation to perform electromagnetic emission measurement.



1.3. Testing Location

Company: TA Technology (Shanghai) Co., Ltd.
Address: No.145, Jintang Rd, Tangzhen Industry Park, Pudong
City: Shanghai
Post code: 201201
Country: P. R. China
Contact: Xu Kai
Telephone: +86-021-50791141/2/3
Fax: +86-021-50791141/2/3-8000
Website: <http://www.ta-shanghai.com>
E-mail: xukai@ta-shanghai.com

2. General Description of Equipment under Test

Client Information

Applicant	Huawei Technologies Co., Ltd.
Applicant address	Administration Building, Headquarters of Huawei Technologies Co., Ltd., Bantian, Longgang District, Shenzhen, 518129, P.R.China.
Manufacturer	Huawei Technologies Co., Ltd.
Manufacturer address	Administration Building, Headquarters of Huawei Technologies Co., Ltd., Bantian, Longgang District, Shenzhen, 518129, P.R.China.

General information

EUT Description	
Model	ANE-LX2J, HWV32
IMEI	/
Hardware Version	HL3ANNEM
Software Version	ANE-LX2J 8.0.0.46(C900)
Power Supply	Battery/AC adapter
Antenna Type	Internal Antenna
Test Mode(s)	U-NII-1(5150MHz-5250MHz) U-NII-2A(5250MHz-5350MHz) U-NII-2C(5470MHz-5725MHz) U-NII-3(5725MHz-5850MHz)
Modulation Type	802.11a/n (HT20/HT40) : OFDM 802.11ac (HT20.HT40/HT80): OFDM
Operating Frequency Range(s)	U-NII-1: 5150-5250MHz U-NII-2A:5250-5350MHz U-NII-2C:5470-5725MHz U-NII-3: 5725-5850MHz



EUT Accessory	
Adapter 1	Manufacture: Salcomp (Shenzhen) Co., Ltd. Model : HW-059200UHQ
Adapter 2	Manufacture: HUIZHOU BYD ELECTRONIC CO., LTD. Model : HW-059200UHQ
Adapter 3	Manufacture: Salcomp (Shenzhen) Co., Ltd. Model : HW-059200AHQ
Adapter 4	Manufacture: HUIZHOU BYD ELECTRONIC CO., LTD. Model : HW-059200AHQ
Adapter 5	Manufacture: Salcomp (Shenzhen) Co., Ltd. Model : HW-059200JHQ
Adapter 6	Manufacture: HUIZHOU BYD ELECTRONIC CO., LTD. Model : HW-059200JHQ
Adapter 7	Manufacture: Salcomp (Shenzhen) Co., Ltd. Model : HW-090200UH0
Adapter 8	Manufacture: SHENZHEN HUNTKEY ELECTRIC CO., LTD Model : HW-090200UH0
Adapter 9	Manufacture: Salcomp (Shenzhen) Co., Ltd. Model : HW-090200AH0
Adapter 10	Manufacture: Salcomp (Shenzhen) Co., Ltd. Model : HW-090200JH0
Adapter 11	Manufacture: SHENZHEN HUNTKEY ELECTRIC CO., LTD Model : HW-090200JH0
Battery 1	Manufacture: SCUD (FUJIAN) Electronics Co., Ltd. Model : HB366481ECW
Battery 2	Manufacture: Sunwoda Electronic CO., LTD. Model : HB366481ECW
Battery 3	Manufacture: Huizhou Desay Battery Co.,Ltd Model : HB366481ECW
Earphone 1	Manufacture:Jiangxi Lianchuang Hongsheng Electronic Co. ,LTD Model : MEMD1532B528A00
Earphone 2	Manufacture: GoerTek Inc. Model : HA1-3W
Earphone 3	Manufacture: FOXCONN INTERCONNECT TECHNOLOGY LIMITED Model : EPAB542-2WH03-DH
Earphone 4	Manufacture: Boluo County Quancheng Electronic Co.,Ltd Model : 1293-3283-3.5mm-300
USB Cable 1	Manufacture: Ningbo Broad Telecommunication Co., Ltd Model : WA0002
USB Cable 2	Manufacture: LUXSHARE Precision Industry Co., Ltd. Model : L99UC093-CS-H
USB Cable 3	Manufacture: HUIZHOU DEHONG TECHNOLOGY CO.,LTD.



	Model : 330-50362
USB Cable 4	Manufacture: HUIZHOU DEHONG TECHNOLOGY CO.,LTD. Model : 130-26988
USB Cable 5	Manufacture: LUXSHARE Precision Industry Co., Ltd. Model : L99UC001-CS-H
USB Cable 6	Manufacture: Dongguan Fuqiang Electronics Co.,Ltd Model : 6691-10YZ-0183
USB Cable 7	Manufacture: HONGFUJIN PRECISION INDUSTRIAL (SHENZHEN).LTD. Model : CUDU01B-HC288-EH
Note: The information of the EUT is declared by the manufacturer.	



3. Applied Standards

According to the specifications of the manufacturer, it must comply with the requirements of the following standards:

FCC CFR47 Part 15E (2017) Unlicensed National Information Infrastructure Devices

ANSI C63.10 (2013)

KDB 789033 D02 General UNII Test Procedures New Rules v02r01

KDB 662911 D01 Multiple Transmitter Output v02r01

4. Test Configuration

Test Mode

The EUT has been associated with peripherals and configuration operated in a manner tended to maximize its emission characteristics in a typical application.

The radiated emission was measured in the following position: EUT stand-up position (Z axis), lie-down position (X, Y axis). The worst emission was found in stand-up position (X axis) and the worst case was recorded.

In order to find the worst case condition, Pre-tests are needed at the presence of different data rate. Preliminary tests have been done on all the configuration for confirming worst case. Data rate below means worst-case rate of each test item.

Wireless Technology and Frequency Range

Wireless Technology		Bandwidth	Channel	Frequency	
Wi-Fi	U-NII-1	20 MHz	36	5180MHz	
			40	5200MHz	
			44	5220MHz	
			48	5240MHz	
		40 MHz	38	5190MHz	
			46	5230MHz	
			80 MHz	42	5210MHz
		U-NII-2A	20 MHz	52	5260MHz
				56	5280MHz
	60			5300MHz	
	64			5320MHz	
	40 MHz		54	5270MHz	
			62	5310MHz	
	U-NII-2C	20 MHz	100	5500MHz	
			104	5520MHz	
			108	5540MHz	
			112	5560MHz	
			116	5580MHz	
			120	5600MHz	
124			5620MHz		
128			5640MHz		
132			5660MHz		
136			5680MHz		
140	5700MHz				



		40 MHz	102	5510MHz
			110	5550MHz
			118	5590MHz
			126	5630MHz
			134	5670MHz
			142	5710MHz
		80 MHz	106	5530MHz
			122	5610MHz
			138	5690MHz
	U-NII-3	20 MHz	149	5745MHz
			157	5785MHz
			165	5825MHz
		40 MHz	151	5755MHz
			159	5795MHz
		80 MHz	155	5775MHz
Does this device support TPC Function? <input type="checkbox"/> Yes <input checked="" type="checkbox"/> No				
Does this device support TDWR Band? <input checked="" type="checkbox"/> Yes <input type="checkbox"/> No				

5. Test Case Results

5.1. Unwanted Emission

Ambient condition

Temperature	Relative humidity	Pressure
23°C ~25°C	45%~50%	101.5kPa

Method of Measurement

The test set-up was made in accordance to the general provisions of ANSI C63.10-2013. The Equipment Under Test (EUT) was set up on a non-conductive table in the semi-anechoic chamber. The test was performed at the distance of 3 m between the EUT and the receiving antenna. The radiated emissions measurements were made in a typical installation configuration. Sweep the whole frequency band range from 9kHz to the 10th harmonic of the carrier, and the emissions less than 20 dB below the permissible value are reported.

During the test, the height of receive antenna shall be moved from 1 to 4 meters, and the antenna shall be performed under horizontal and vertical polarization. The turntable shall be rotated from 0 to 360 degrees for detecting the maximum of radiated spurious signal level. The measurements shall be repeated with orthogonal polarization of the test antenna. The data of cable loss and antenna factor has been calibrated in full testing frequency range before the testing.

Set the spectrum analyzer in the following:

Below 1GHz (detector: Peak and Quasi-Peak)

RBW=100kHz / VBW=300kHz / Sweep=AUTO

Above 1GHz (detector: Peak):

I) Peak emission levels are measured by setting the instrument as follows:

1) RBW = 1 MHz.

2) VBW \geq [3 \times RBW]

3) Detector = peak.

4) Sweep time = auto.

5) Trace mode = max hold.

6) Allow sweeps to continue until the trace stabilizes. Note that if the transmission is not continuous, then the time required for the trace to stabilize will increase by a factor of approximately 1 / D, where D is the duty cycle.

II) Average emission levels are measured by setting the instrument as follows:

a) RBW = 1 MHz.

b) VBW \geq [3 \times RBW].

c) Detector = RMS (power averaging), if [span / (# of points in sweep)] \leq RBW / 2. Satisfying this condition can require increasing the number of points in the sweep or reducing the span. If the condition is not satisfied, then the detector mode shall be set to peak.

d) Averaging type = power (i.e., rms) (As an alternative, the detector and averaging type may be set



for linear voltage averaging. Some instruments require linear display mode to use linear voltage averaging. Log or dB averaging shall not be used.)

e) Sweep time = auto.

f) Perform a trace average of at least 100 traces if the transmission is continuous. If the transmission is not continuous, then the number of traces shall be increased by a factor of $1 / D$, where D is the duty cycle. For example, with 50% duty cycle, at least 200 traces shall be averaged. (If a specific emission is demonstrated to be continuous—i.e., 100% duty cycle—then rather than turning ON and OFF with the transmit cycle, at least 100 traces shall be averaged.)

g) If tests are performed with the EUT transmitting at a duty cycle less than 98%, then a correction factor shall be added to the measurement results prior to comparing with the emission limit, to compute the emission level that would have been measured had the test been performed at 100% duty cycle. The correction factor is computed as follows:

1) If power averaging (rms) mode was used in the preceding step e), then the correction factor is $[10 \log (1 / D)]$, where D is the duty cycle. For example, if the transmit duty cycle was 50%, then 3 dB shall be added to the measured emission levels.

2) If linear voltage averaging mode was used in the preceding step e), then the correction factor is $[20 \log (1 / D)]$, where D is the duty cycle. For example, if the transmit duty cycle was 50%, then 6 dB shall be added to the measured emission levels.

3) If a specific emission is demonstrated to be continuous (100% duty cycle) rather than turning ON and OFF with the transmit cycle, then no duty cycle correction is required for that emission.

The field strength of spurious emission was measured in the following position: EUT stand-up position (Z axis), lie-down position (X, Y axis). The worst emission was found in stand-up position (Z axis) and the antenna is vertical.

The test is in transmitting mode.

9KHz~~~30MHz

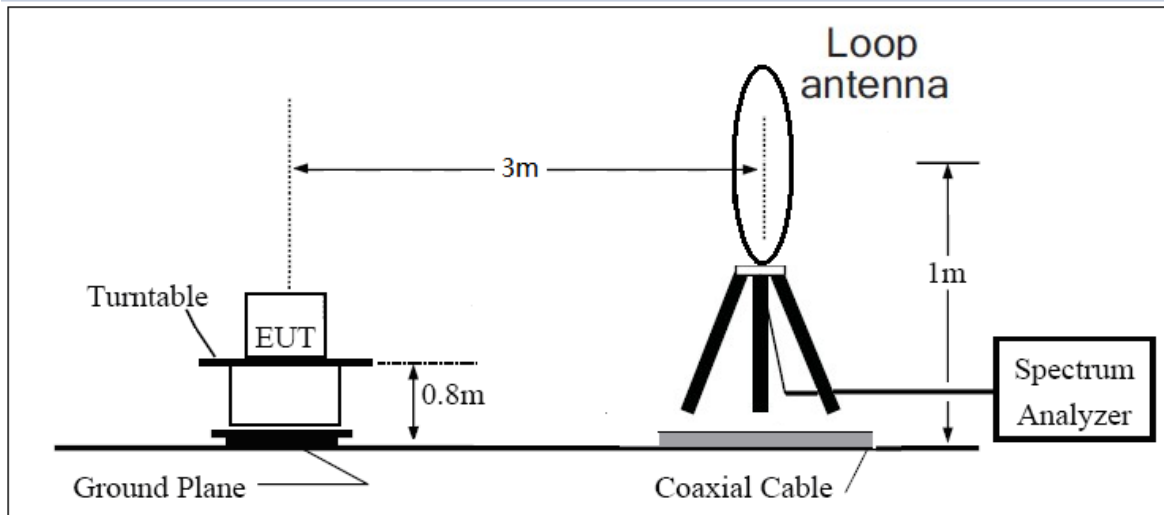

30MHz~~~ 1GHz

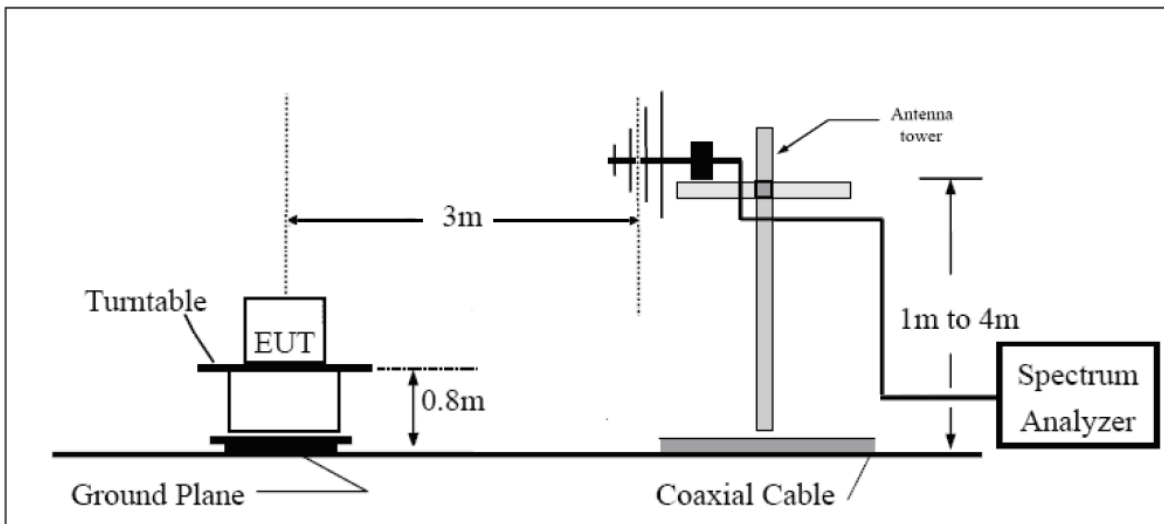

Above 1GHz

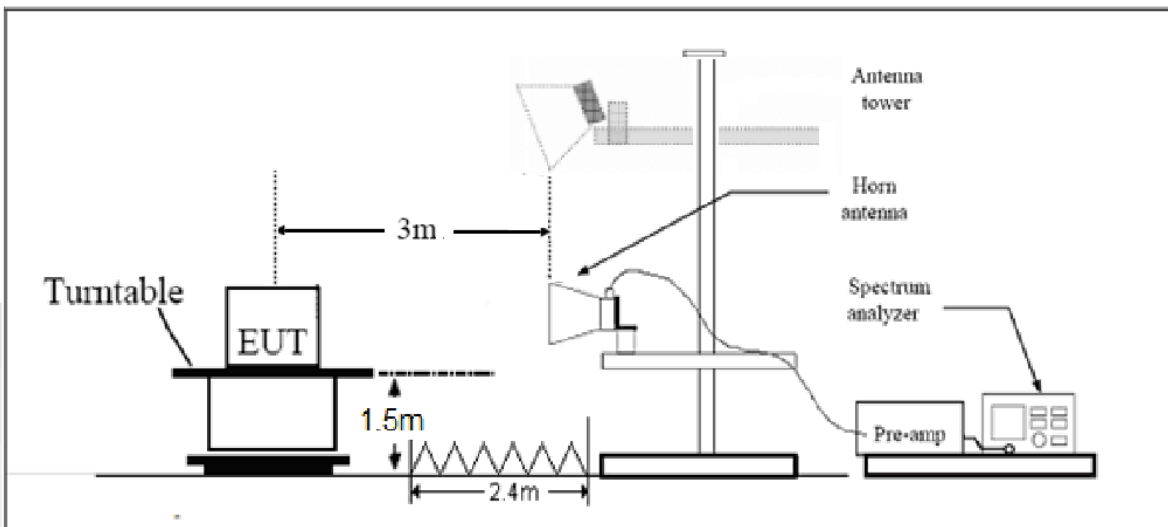

Note: Area side:2.4mX3.6m

Limits

- (1) For transmitters operating in the 5725-5850 MHz band: All emissions shall be limited to a level of -27 dBm/MHz at 75 MHz or more above or below the band edge increasing linearly to 10 dBm/MHz at 25 MHz above or below the band edge, and from 25 MHz above or below the band edge increasing linearly to a level of 15.6 dBm/MHz at 5 MHz above or below the band edge, and from 5 MHz above or below the band edge increasing linearly to a level of 27 dBm/MHz at the band edge.
- (2) For transmitters operating in the 5.15-5.25 GHz band: All emissions outside of the 5.15-5.35 GHz band shall not exceed an e.i.r.p. of -27 dBm/MHz(68.2dBμV/m).
- (3) For transmitters operating in the 5.25-5.35 GHz band: All emissions outside of the 5.15-5.35 GHz band shall not exceed an e.i.r.p. of -27 dBm/MHz(68.2dBμV/m).
- (4) For transmitters operating in the 5.47-5.725 GHz band: All emissions outside of the 5.47-5.725 GHz band shall not exceed an e.i.r.p. of -27 dBm/MHz(68.2dBμV/m).

Note: the following formula is used to convert the EIRP to field strength

§1、 $E[\text{dB}\mu\text{V}/\text{m}] = \text{EIRP}[\text{dBm}] - 20 \log(d[\text{meters}]) + 104.77$, where E = field strength and

d = distance at which field strength limit is specified in the rules;

§2、 $E[\text{dB}\mu\text{V}/\text{m}] = \text{EIRP}[\text{dBm}] + 95.2$, for d = 3 meters

- (5) Unwanted spurious emissions fallen in restricted bands per FCC Part15.205 shall comply with the general field strength limits set forth in § 15.209 as below table.

Frequency of emission (MHz)	Field strength(uV/m)	Field strength(dBuV/m)
0.009–0.490	2400/F(kHz)	/
0.490–1.705	24000/F(kHz)	/
1.705–30.0	30	/
30-88	100	40
88-216	150	43.5
216-960	200	46
Above960	500	54



MHz	MHz	MHz	GHz
0.090 - 0.110	16.42 - 16.423	399.9 - 410	4.5 - 5.15
0.495 - 0.505	16.69475 - 16.69525	608 - 614	5.35 - 5.46
2.1735 - 2.1905	16.80425 - 16.80475	960 - 1240	7.25 - 7.75
4.125 - 4.128	25.5 - 25.67	1300 - 1427	8.025 - 8.5
4.17725 - 4.17775	37.5 - 38.25	1435 - 1626.5	9.0 - 9.2
4.20725 - 4.20775	73 - 74.6	1645.5 - 1646.5	9.3 - 9.5
6.215 - 6.218	74.8 - 75.2	1660 - 1710	10.6 - 12.7
6.26775 - 6.26825	108 - 121.94	1718.8 - 1722.2	13.25 - 13.4
6.31175 - 6.31225	123 - 138	2200 - 2300	14.47 - 14.5
8.291 - 8.294	149.9 - 150.05	2310 - 2390	15.35 - 16.2
8.362 - 8.366	156.52475 - 156.52525	2483.5 - 2500	17.7 - 21.4
8.37625 - 8.38675	156.7 - 156.9	2690 - 2900	22.01 - 23.12
8.41425 - 8.41475	162.0125 - 167.17	3260 - 3267	23.6 - 24.0
12.29 - 12.293	167.72 - 173.2	3332 - 3339	31.2 - 31.8
12.51975 - 12.52025	240 - 285	3345.8 - 3358	36.43 - 36.5
12.57675 - 12.57725	322 - 335.4	3600 - 4400	(²)
13.36 - 13.41			

Measurement Uncertainty

The assessed measurement uncertainty to ensure 95% confidence level for the normal distribution is with the coverage factor $k = 1.96$.

Frequency	Uncertainty
9KHz-30MHz	3.55 dB
30MHz-200MHz	4.19 dB
200MHz-1GHz	3.63 dB
1GHz-26.5G	3.68 dB
26.5G-40GHz	4.76dB



Test Results:

The signal beyond the limit is carrier.

U-NII-1

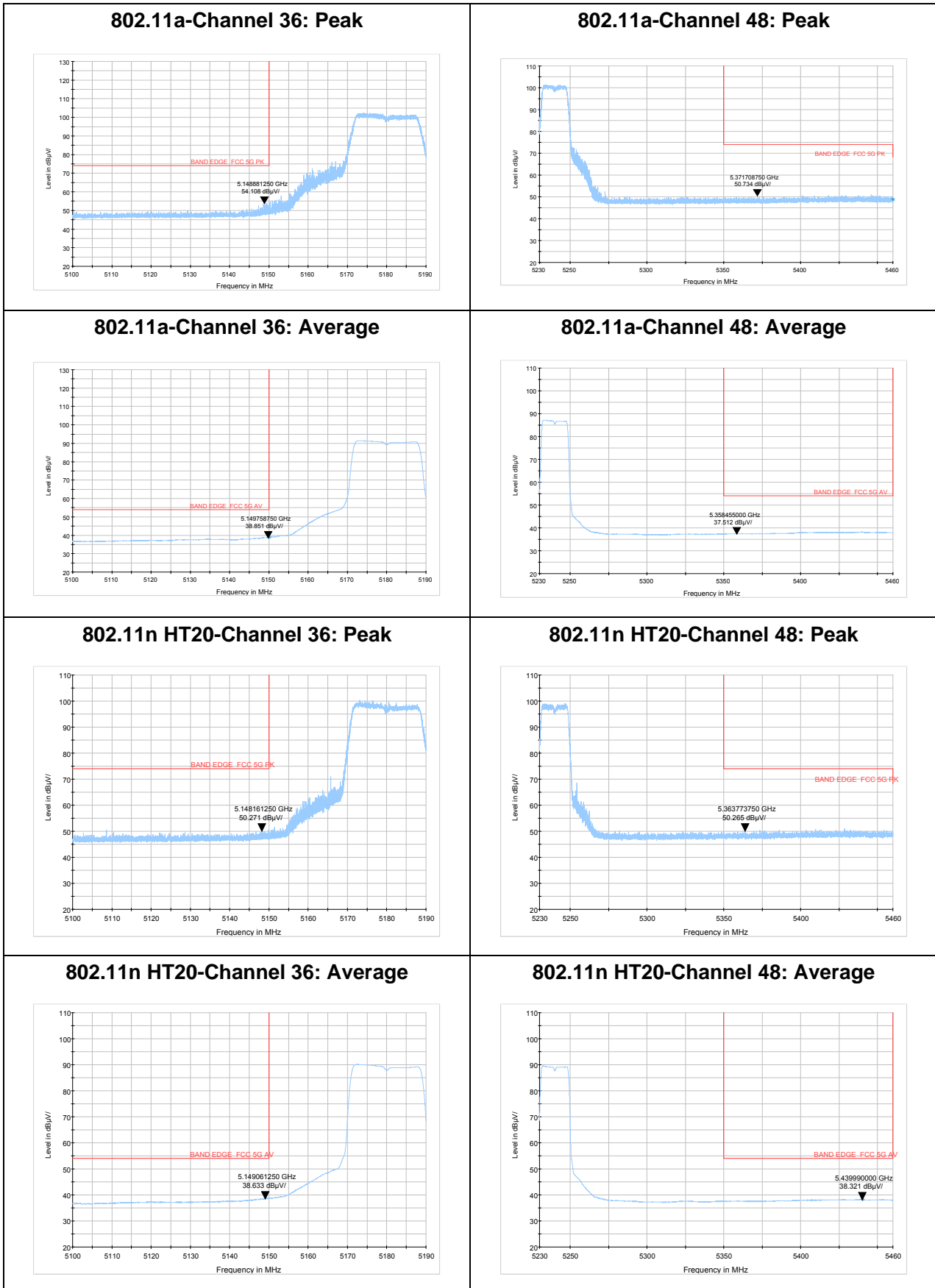



802.11n HT40-Channel 38: Peak

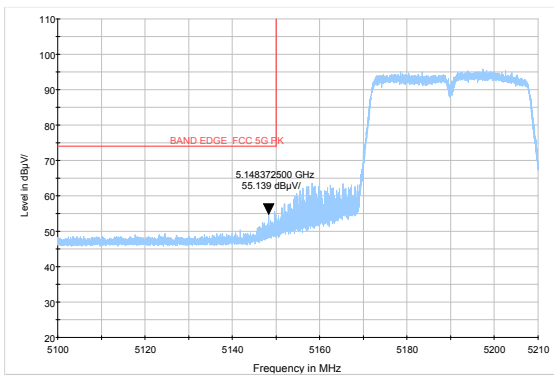

802.11n HT40-Channel 46: Peak

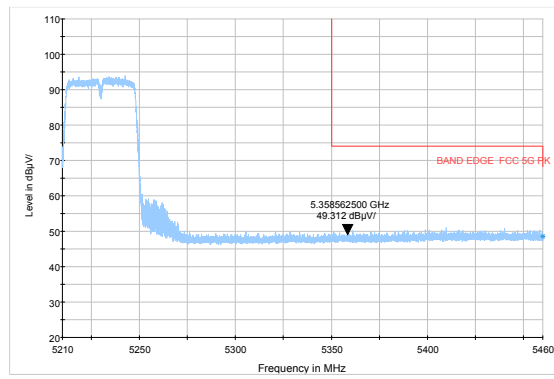

802.11n HT40-Channel 38: Average

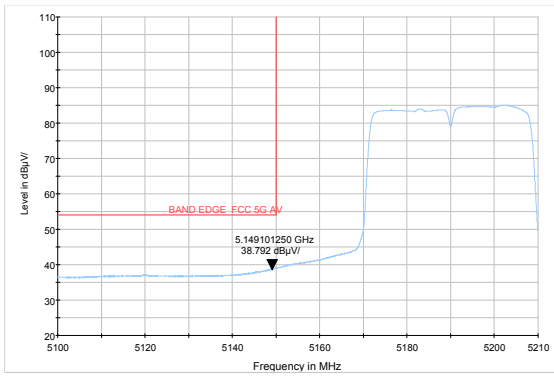

802.11n HT40-Channel 46: Average

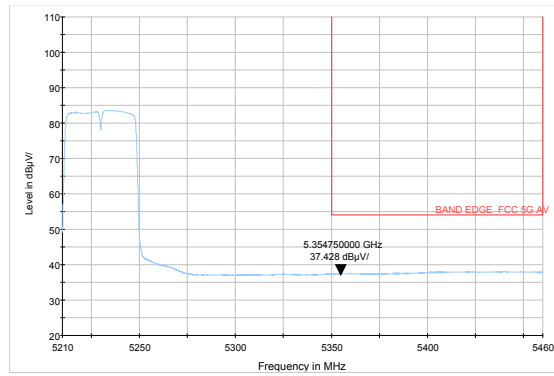

802.11ac HT20 -Channel 36: Peak

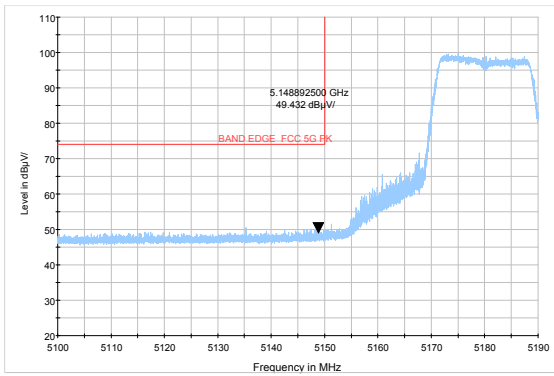

802.11ac HT20 -Channel 48: Peak

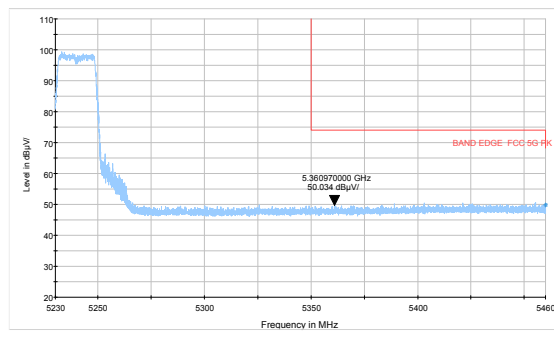

802.11ac HT20-Channel 36: Average

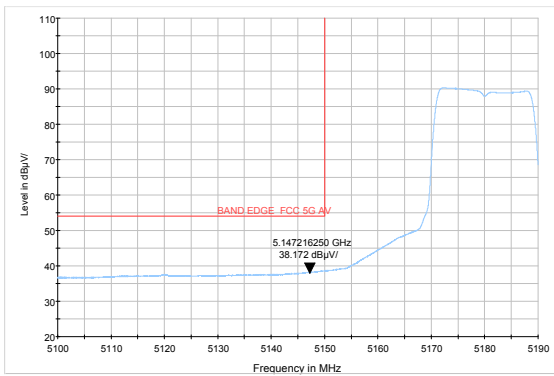

802.11ac HT20 -Channel 48: Average

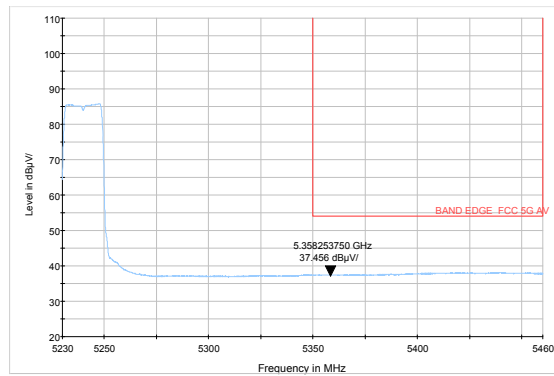



802.11ac HT40-Channel 38: Peak

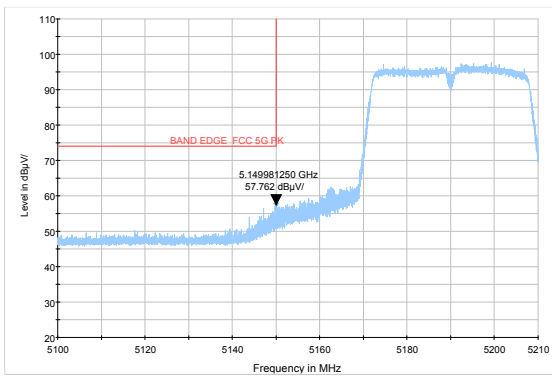

802.11ac HT40-Channel 46: Peak

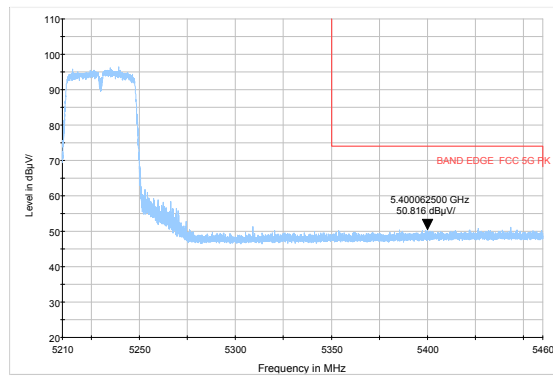

802.11ac HT40-Channel 38: Average

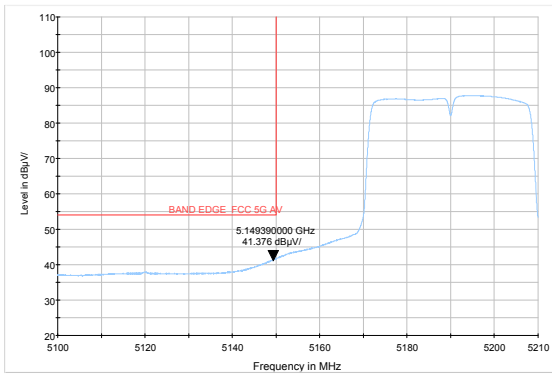

802.11ac HT40-Channel 46: Average

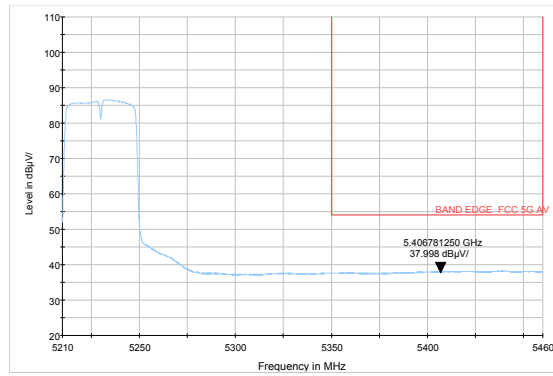

802.11ac HT80 -Channel 42: Peak

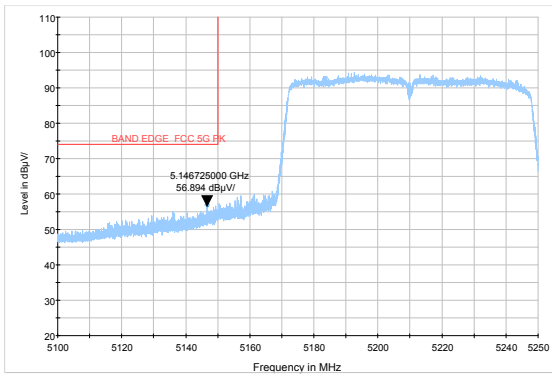

802.11ac HT80- Channel 42: Average

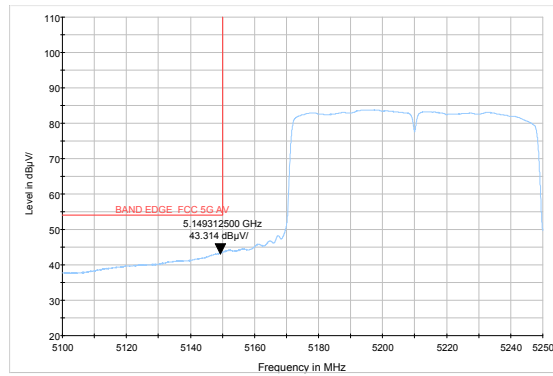



U-NII-2A

802.11a-Channel 52: Peak

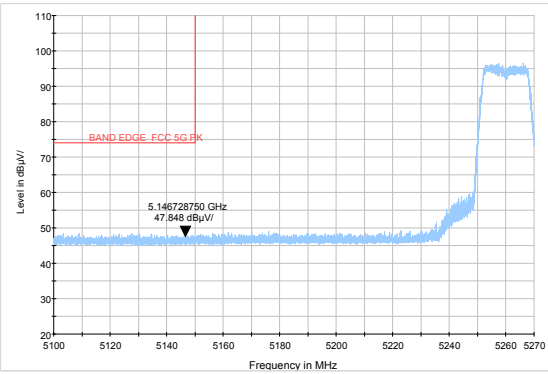

802.11a-Channel 64: Peak

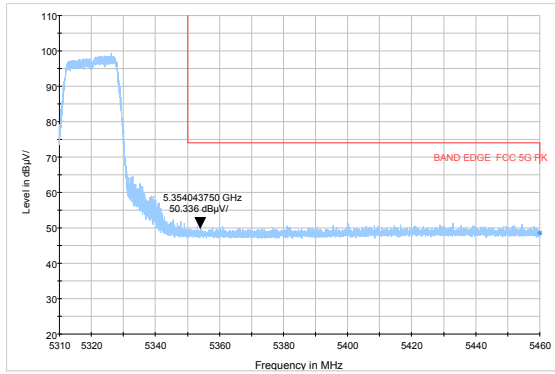

802.11a-Channel 52: Average

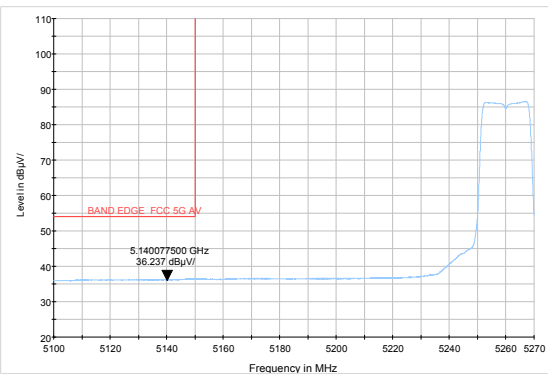

802.11a-Channel 64: Average

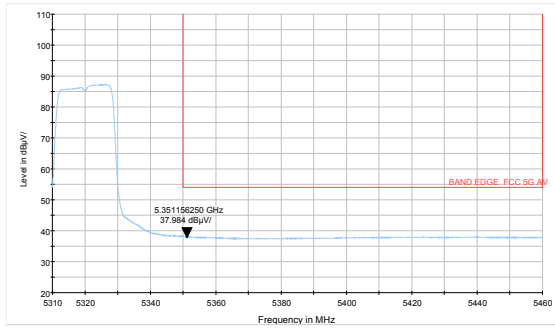

802.11n HT20-Channel 52: Peak

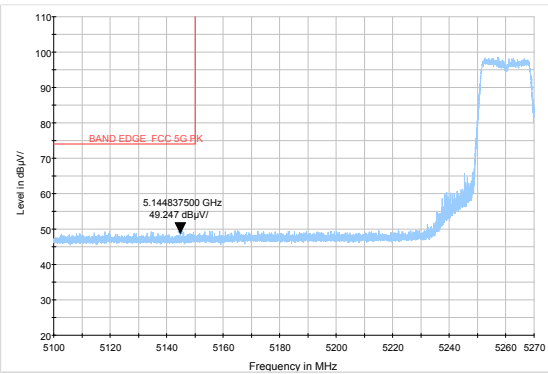

802.11n HT20-Channel 64: Peak

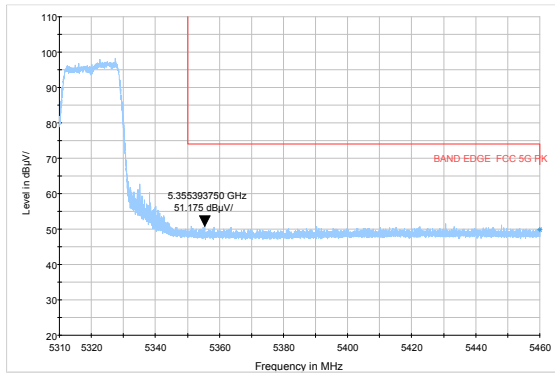

802.11n HT20-Channel 52: Average

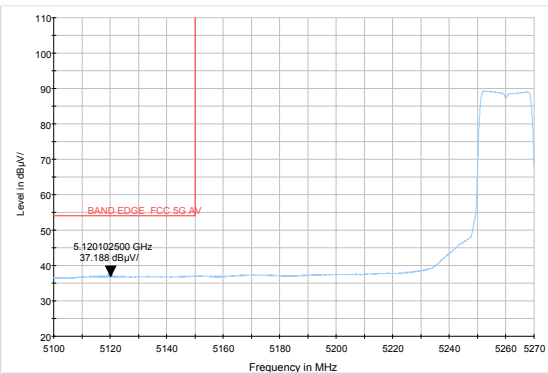

802.11n HT20-Channel 64: Average

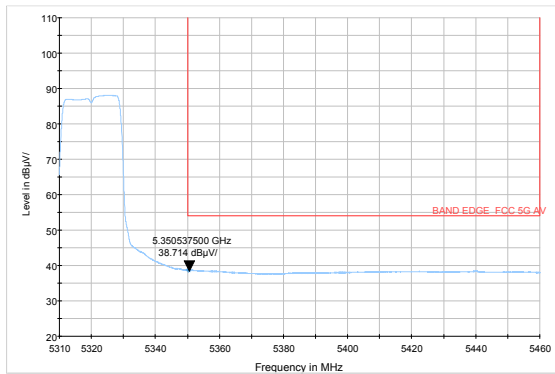



802.11n HT40-Channel 54: Peak

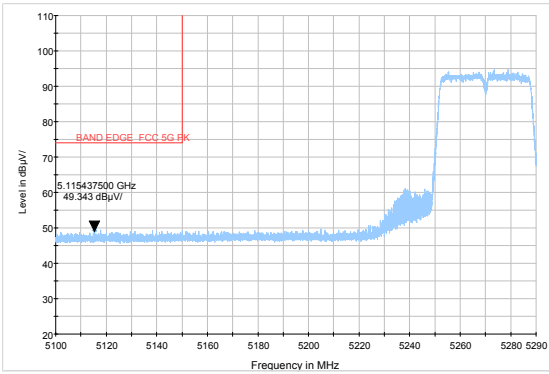

802.11n HT40-Channel 62: Peak

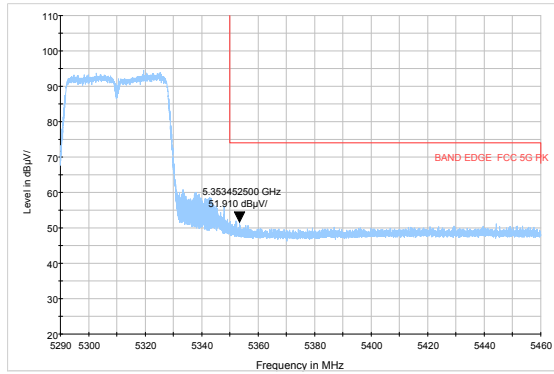

802.11n HT40-Channel 54: Average

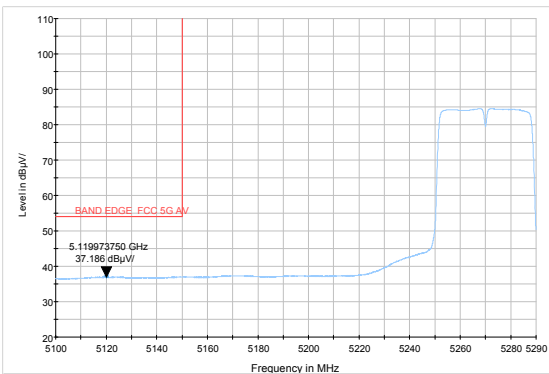

802.11n HT40-Channel 62: Average

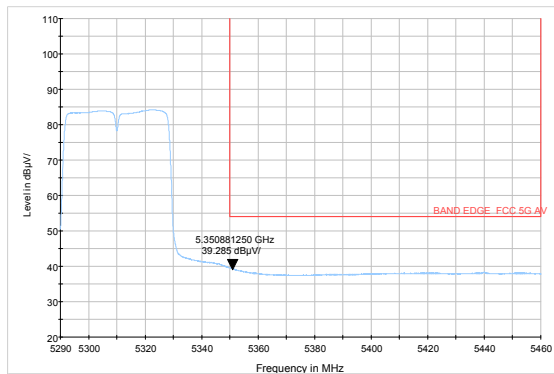

802.11ac HT20 -Channel 52: Peak

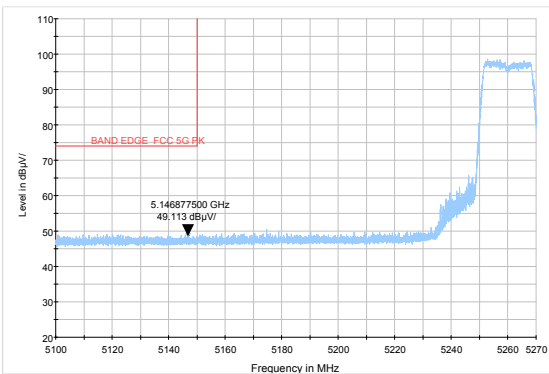

802.11ac HT20 -Channel 64: Peak

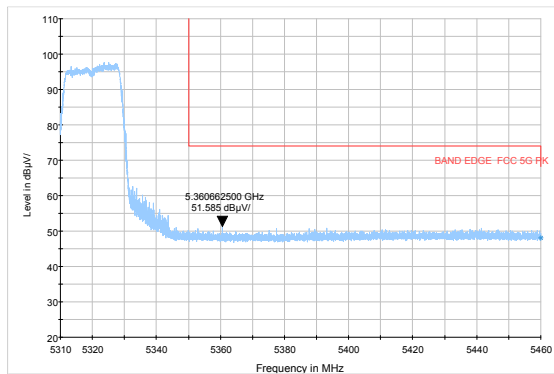

802.11ac HT20-Channel 52: Average

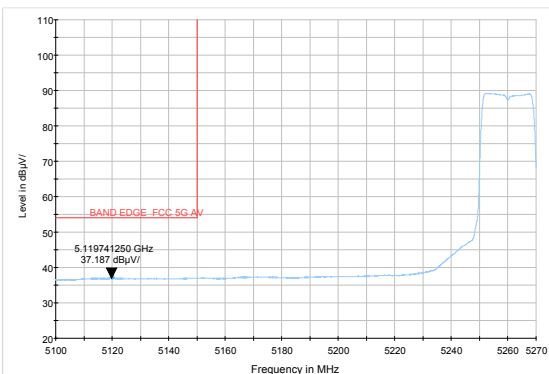

802.11ac HT20 -Channel 64: Average

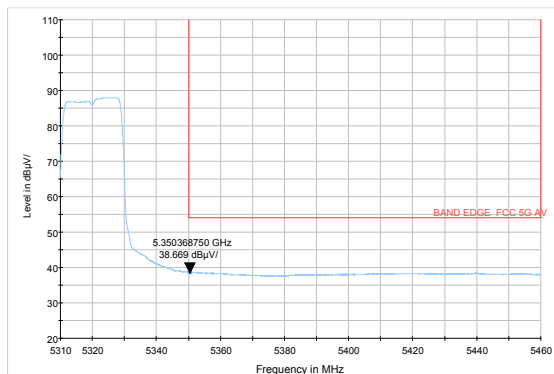



802.11ac HT40-Channel 54: Peak

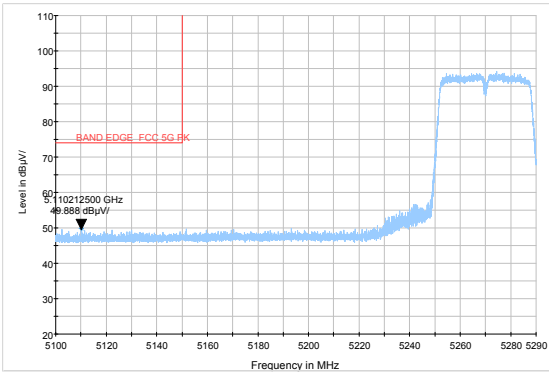

802.11ac HT40-Channel 62: Peak

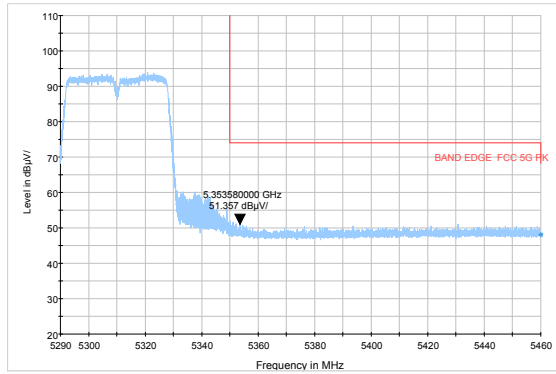

802.11ac HT40-Channel 54: Average

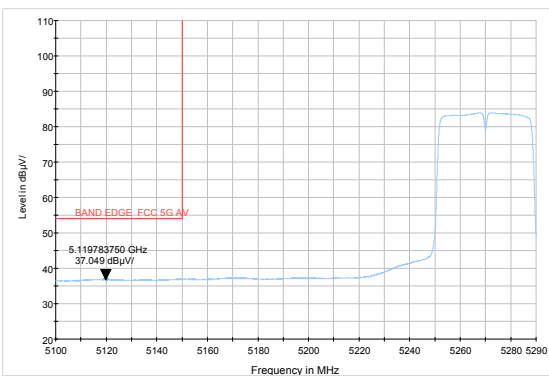

802.11ac HT40-Channel 62: Average

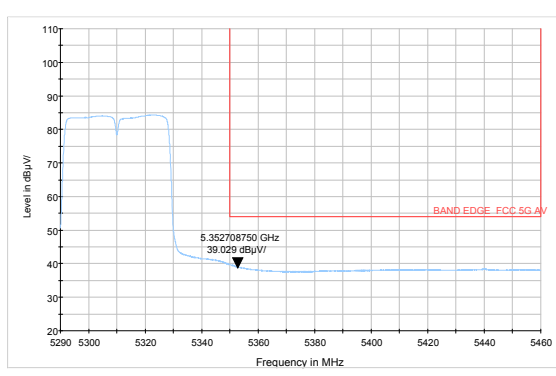

802.11ac HT80 -Channel 58: Peak

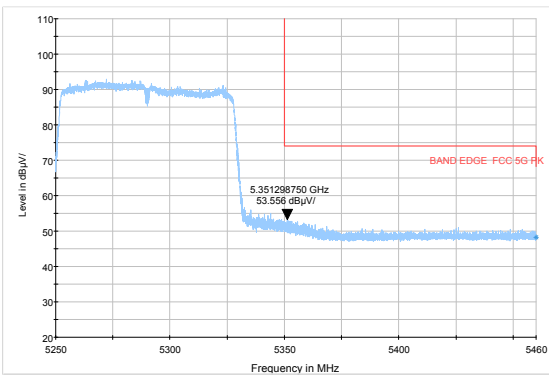

802.11ac HT80- Channel 58: Average

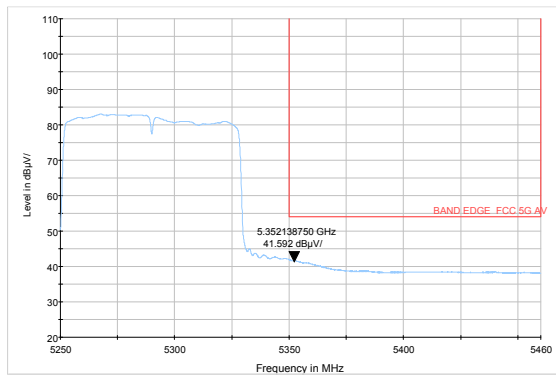



U-NII-2C

802.11a-Channel 100: Peak

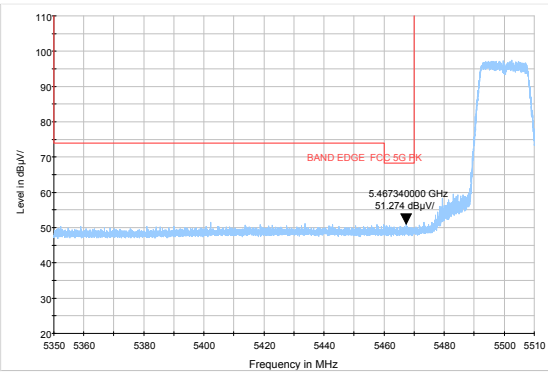

802.11a-Channel 140: Peak

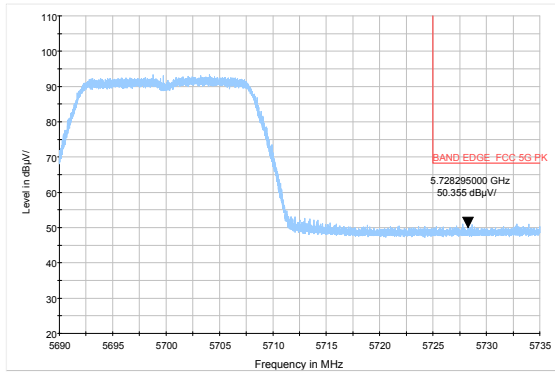

802.11a-Channel 100: Average

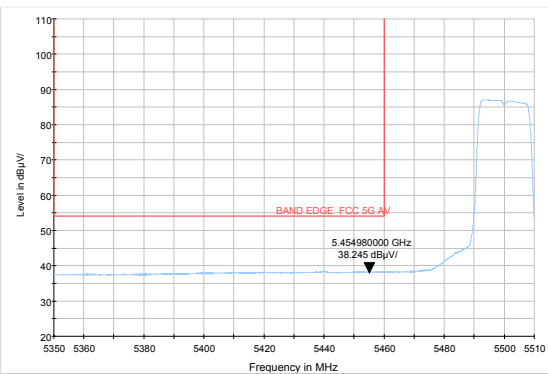

802.11n HT20-Channel 100: Peak

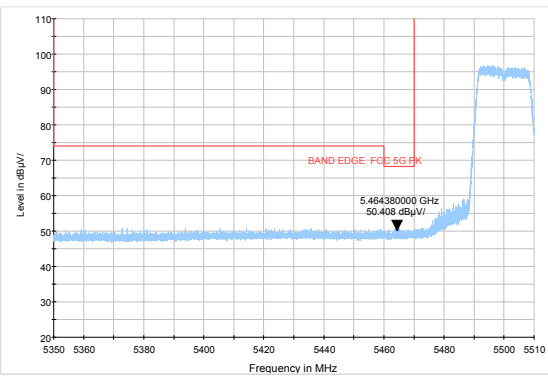

802.11n HT20-Channel 140: Peak

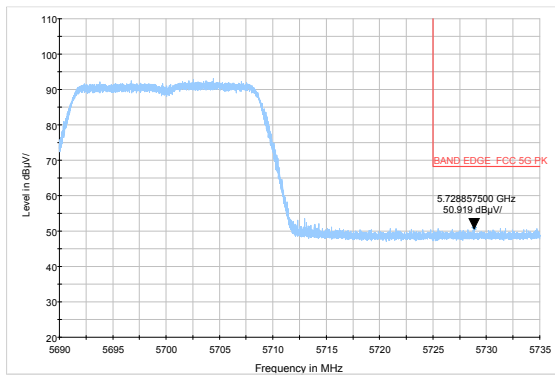

802.11n HT20-Channel 100: Average

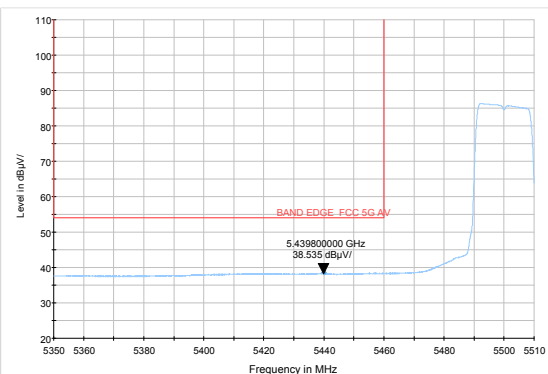



802.11n HT40-Channel 102: Peak

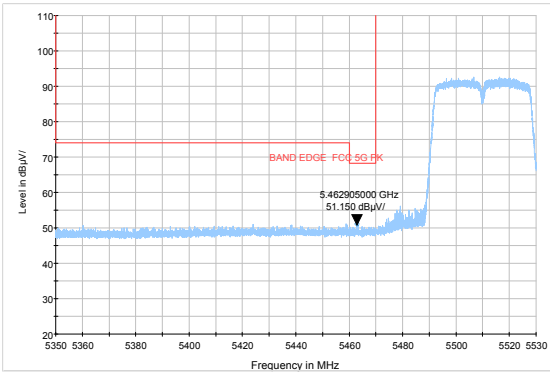

802.11n HT40-Channel 134: Peak

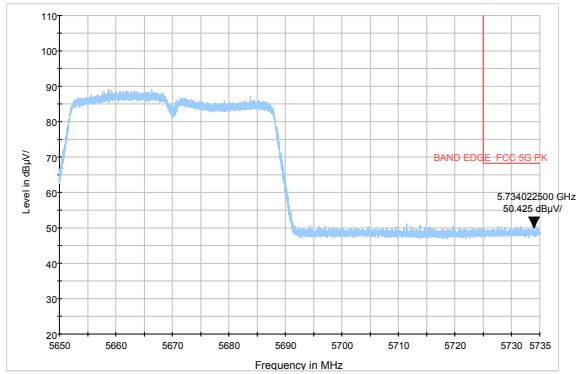

802.11n HT40-Channel 102: Average

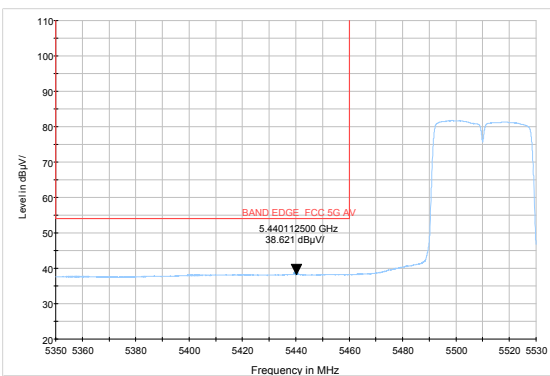

802.11ac HT20 -Channel 100: Peak

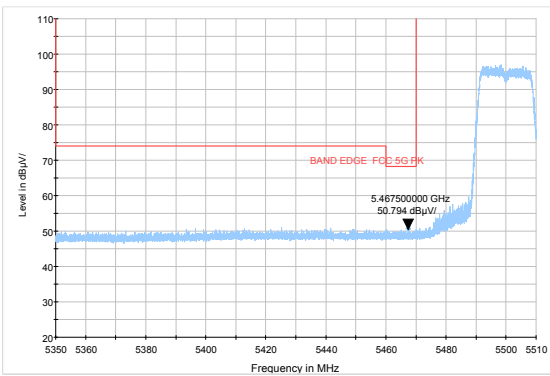

802.11ac HT20 -Channel 140: Peak

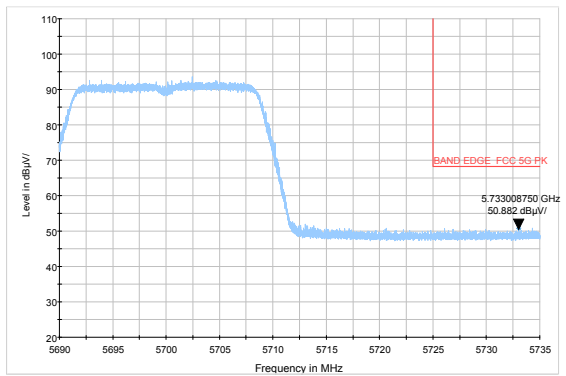

802.11ac HT20-Channel 100: Average

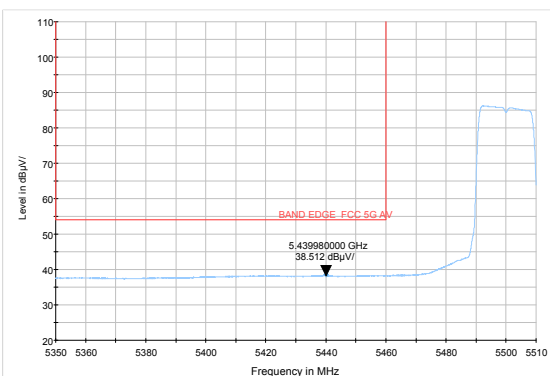



802.11ac HT40-Channel 102: Peak

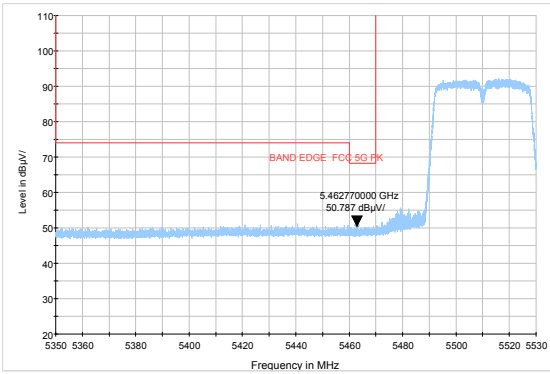

802.11ac HT40-Channel 134: Peak

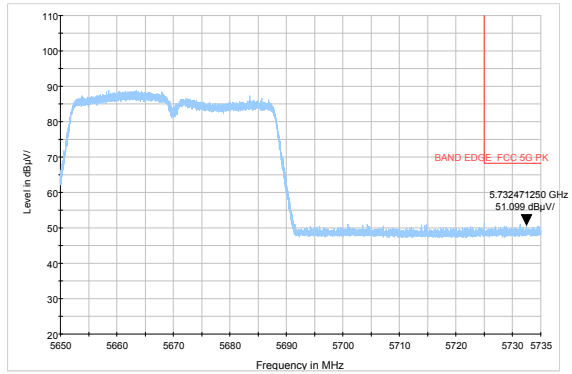

802.11ac HT40-Channel 102: Average

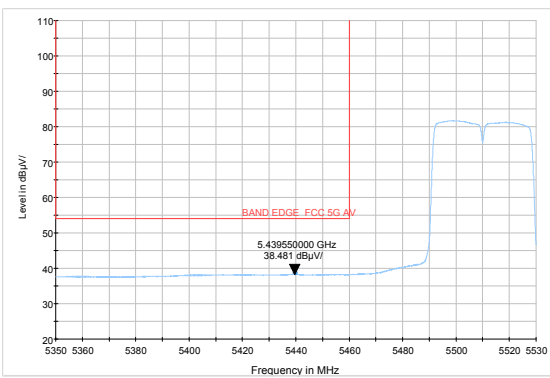

802.11ac HT80 -Channel 106: Peak

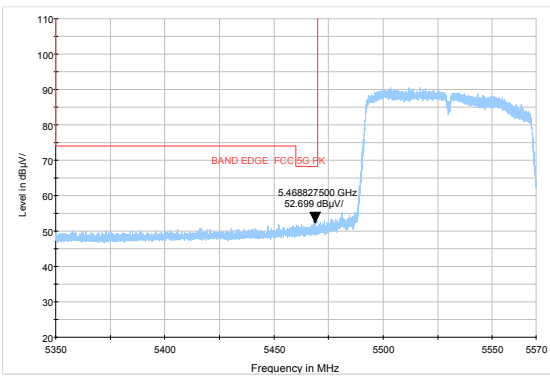

802.11ac HT80 -Channel 138: Peak

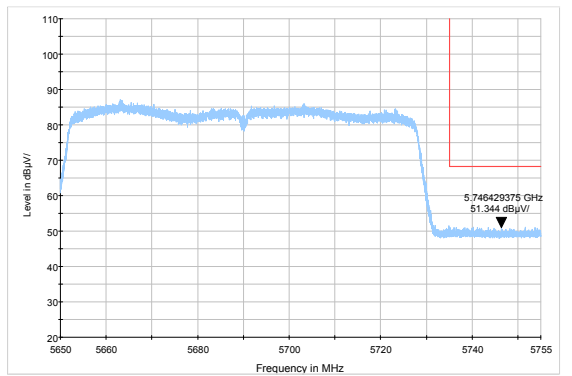

802.11ac HT80- Channel 106: Average

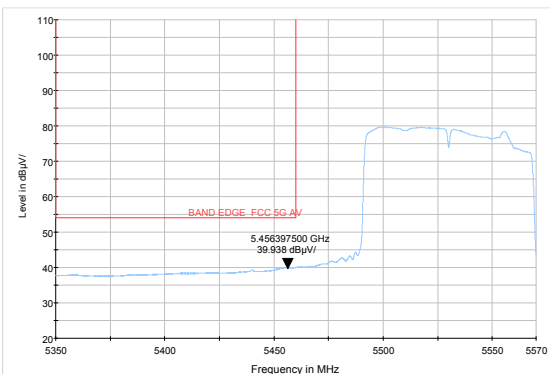



U-NII-3

802.11a-Channel 149: Peak

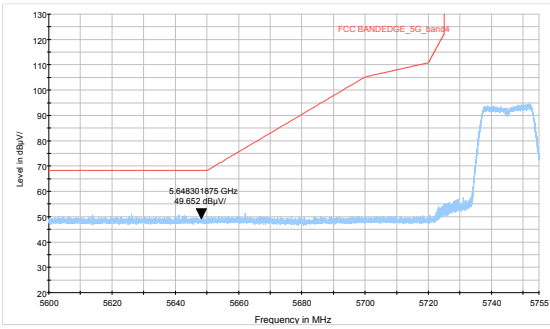

802.11a-Channel 165: Peak

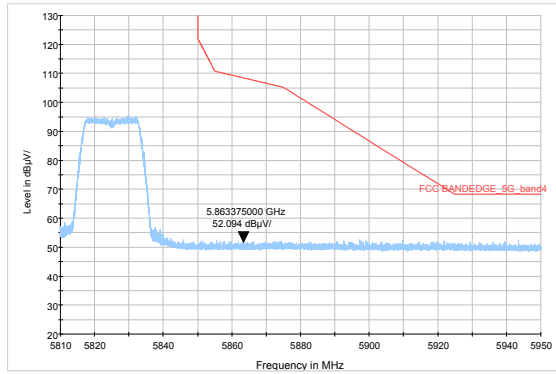

802.11n HT20-Channel 149: Peak

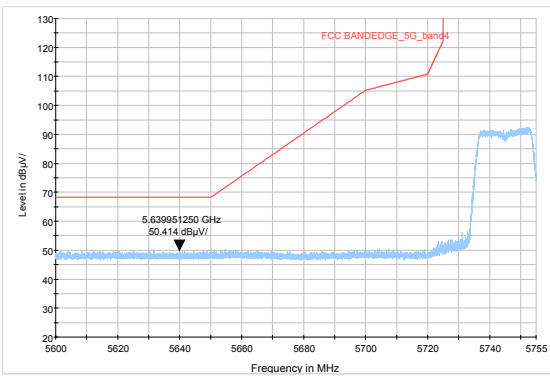

802.11n HT20-Channel 165: Peak

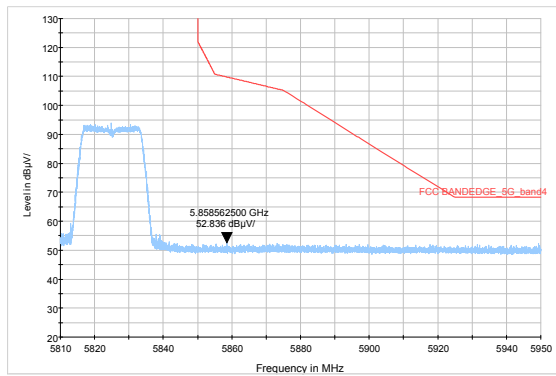

802.11n HT40-Channel 151: Peak

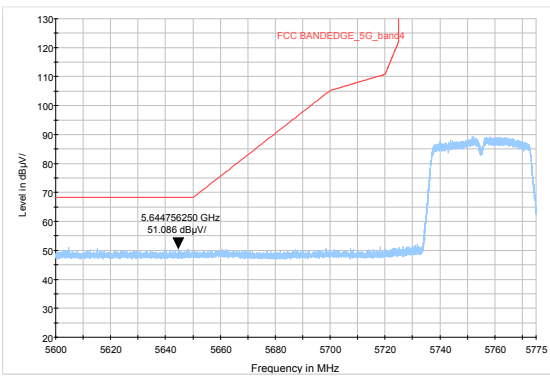

802.11n HT40-Channel 159: Peak

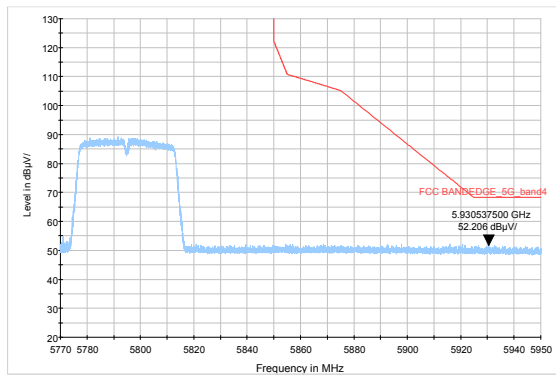

802.11ac HT20-Channel 149: Peak

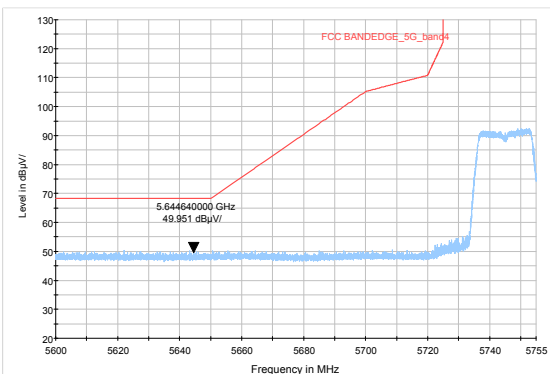

802.11ac HT20-Channel 165: Peak

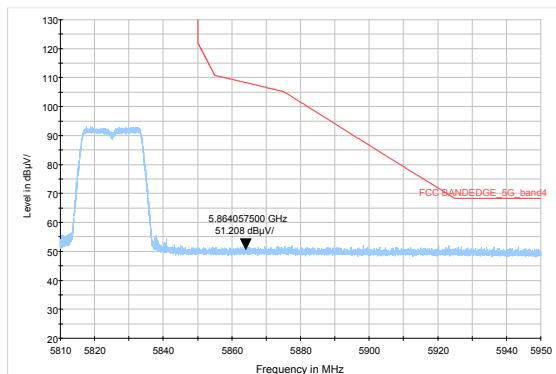



802.11ac HT40-Channel 151: Peak

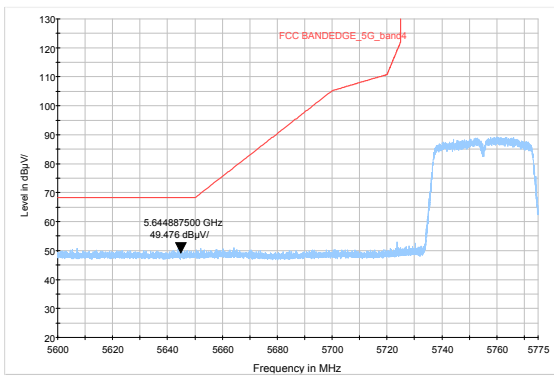

802.11ac HT40-Channel 159: Peak

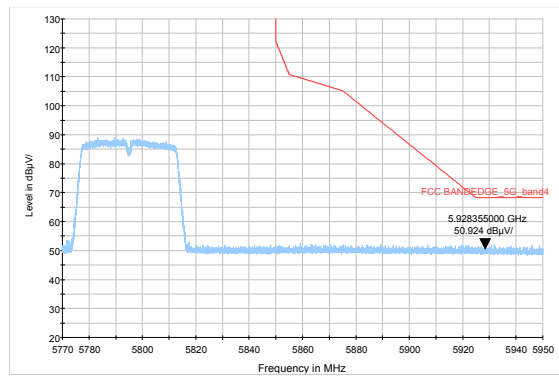

802.11ac HT80- Channel 155: Peak

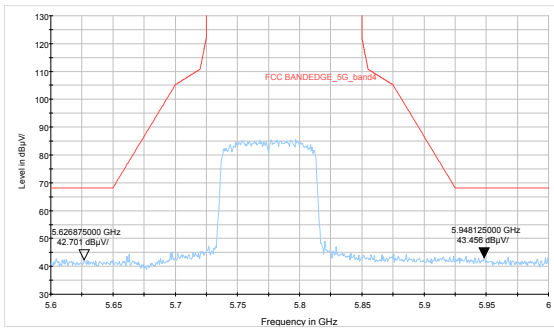

Result of RE

Test result

Sweep the whole frequency band through the range from 9kHz to the 10th harmonic of the carrier, and 9KHz-30MHz, the emissions more than 20 dB below the permissible value are not reported.

During the test, the Radiates Emission from 30MHz to 1GHz was performed in all modes with all channels, 802.11ac (HT80), Channel42 are selected as the worst condition. The test data of the worst-case condition was recorded in this report.

Continuous TX mode:

FCC RE 0.03-1GHz QP Class B

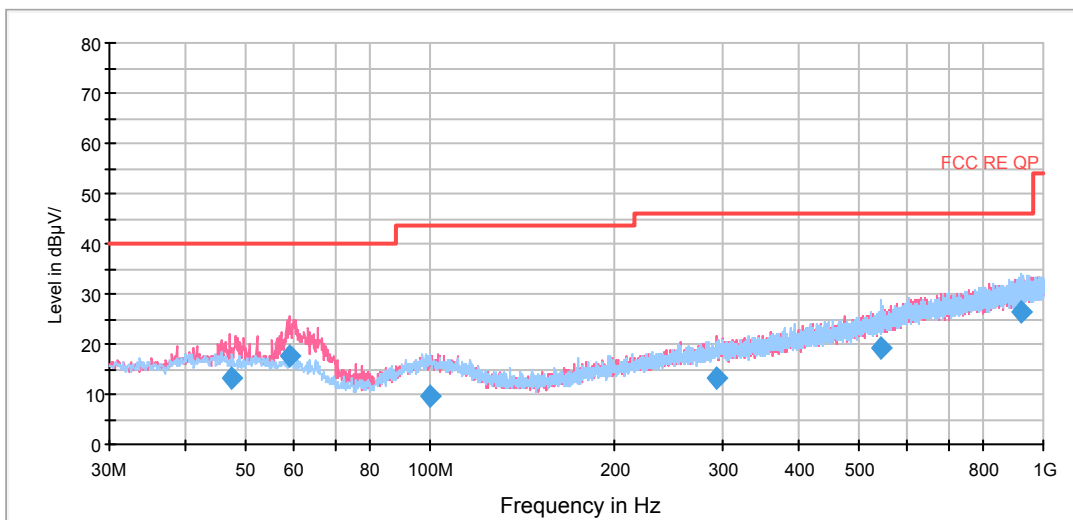

Radiates Emission from 30MHz to 1GHz

Frequency (MHz)	Quasi-Peak (dBuV/m)	Reading value (dBuV/m)	Height (cm)	Polarization	Azimuth (deg)	Correct Factor (dB)	Margin (dB)	Limit (dBuV/m)
47.536250	13.1	0.0	100.0	V	162.0	13.1	26.9	40.0
58.977500	17.8	5.1	100.0	V	139.0	12.7	22.2	40.0
99.965000	9.6	-3.7	125.0	H	20.0	13.3	33.9	43.5
293.875000	13.2	-2.4	125.0	V	34.0	15.6	32.8	46.0
543.977500	19.1	-2.5	125.0	H	26.0	21.6	26.9	46.0
923.972500	26.2	-0.7	100.0	H	96.0	26.9	19.8	46.0

- Remark:**
1. Quasi-Peak = Reading value + Correction factor
 2. Correction Factor = Antenna factor+ Insertion loss(cable loss+amplifier gain)
 3. Margin = Limit – Quasi-Peak



802.11a CH36

FCC RE 1G-3GHz PK+AV Class B

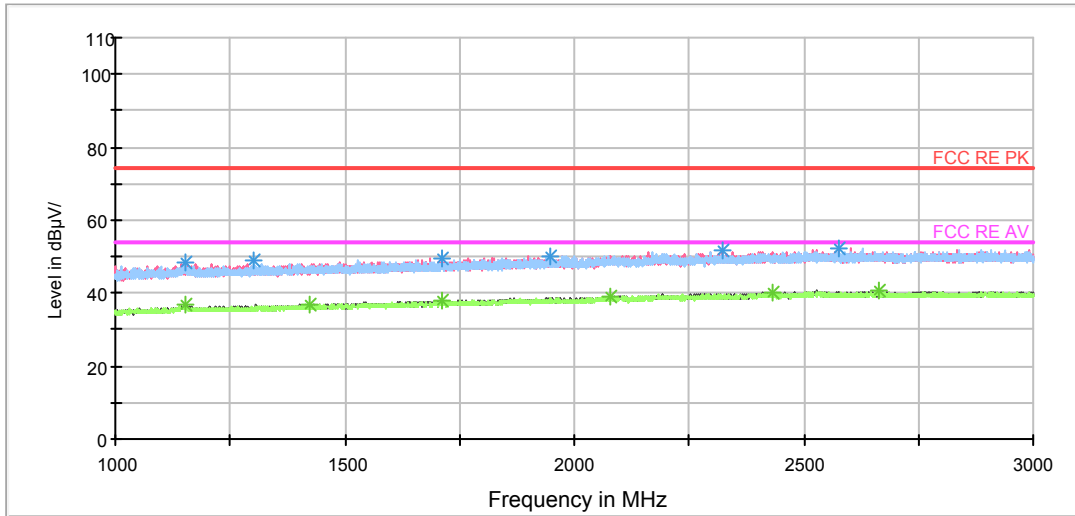

Radiates Emission from 1GHz to 3GHz

RE 3-18GHz AV

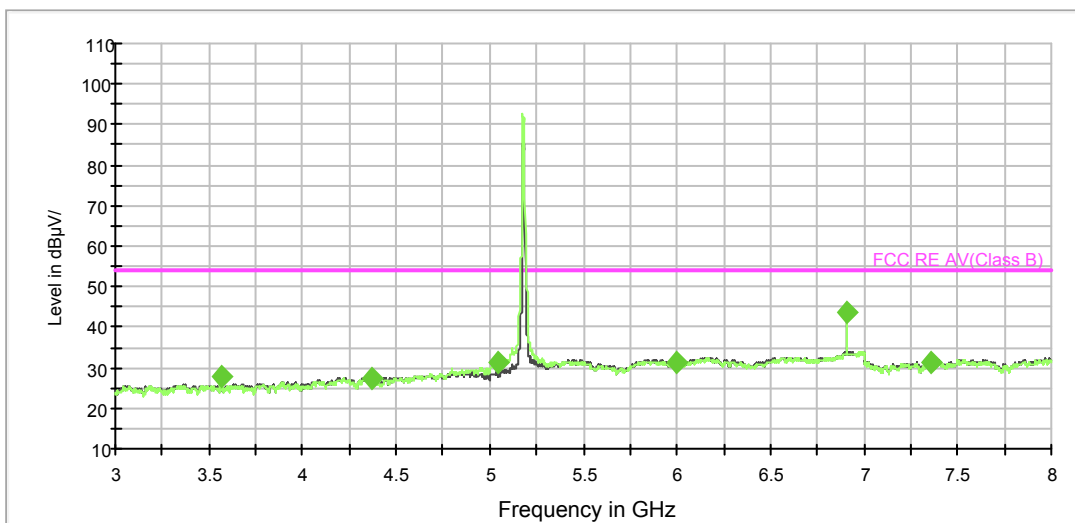

RE 3-18GHz PK+AV

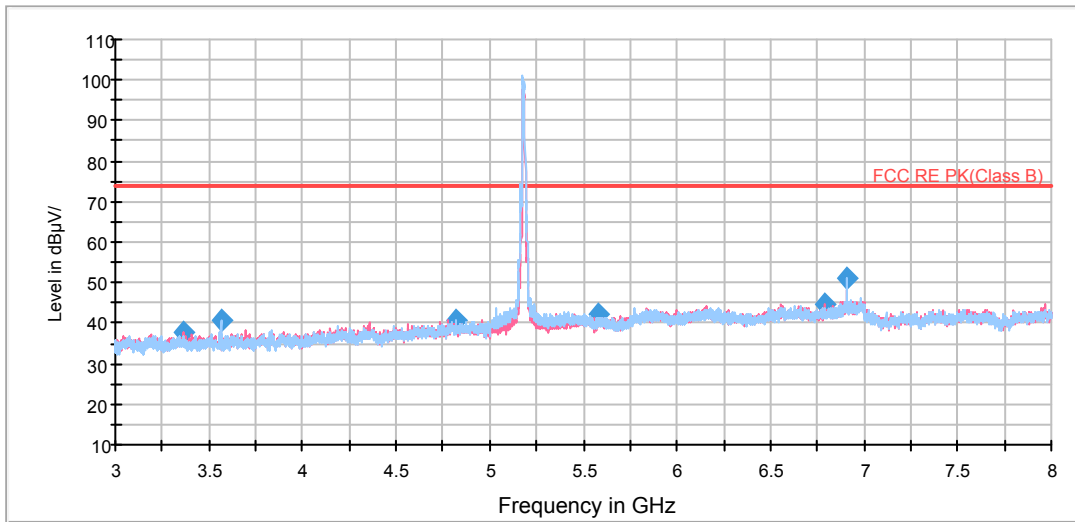

Note: The signal beyond the limit is carrier.
Radiates Emission from 3GHz to 8GHz

RE 3-18GHz PK+AV

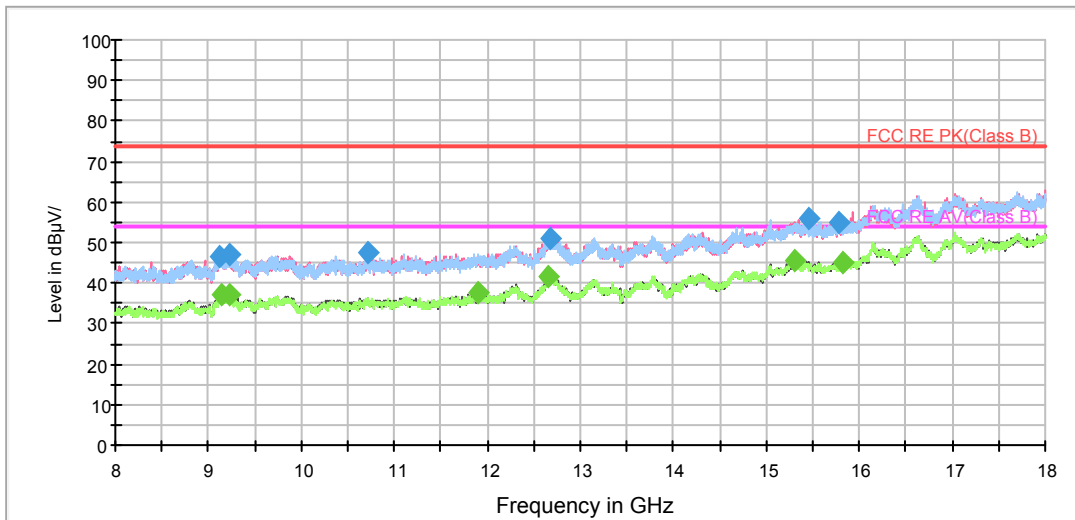

Radiates Emission from 8GHz to 18GHz

RE 18-26.5GHz PK+AV

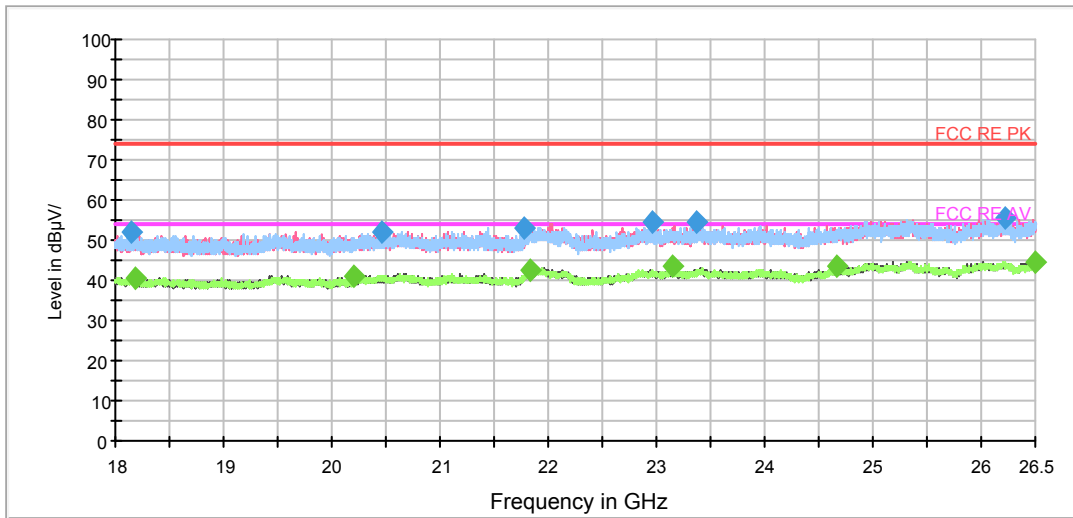

Radiates Emission from 18GHz to 26.5GHz

RE 26.5-40GHz PK+AV Class B

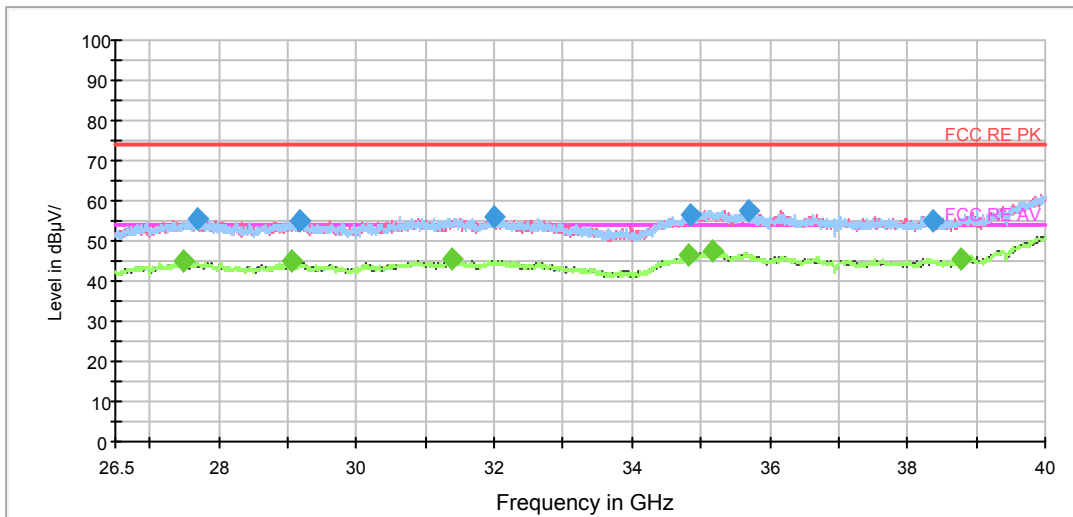

Radiates Emission from 26.5GHz to 40GHz

Frequency (MHz)	Peak (dBuV/m)	Height (cm)	Polarization	Azimuth (deg)	Reading value (dBuV/m)	Correct Factor (dB)	Margin (dB)	Limit (dBuV/m)
3362.500000	37.6	100.0	V	0.0	39.9	-2.3	36.4	74
3562.500000	40.4	100.0	H	14.0	42.5	-2.1	33.6	74
4823.125000	40.8	100.0	H	65.0	39.4	1.4	33.2	74
5576.875000	42.0	100.0	H	14.0	39.9	2.1	32.0	74
6789.375000	44.5	100.0	V	316.0	38.8	5.7	29.5	74
6906.875000	51.3	100.0	H	350.0	45.0	6.3	22.7	74

Remark: 1. Correction Factor = Antenna factor+ Insertion loss (cable loss + amplifier gain)



Frequency (MHz)	Average (dBuV/m)	Height (cm)	Polarization	Azimuth (deg)	Reading value (dBuV/m)	Correct Factor (dB)	Margin (dB)	Limit (dBuV/m)
3563.750000	27.7	200.0	H	0.0	29.8	-2.1	26.3	54
4371.875000	27.2	200.0	V	164.0	26.8	0.4	26.8	54
5044.375000	31.1	200.0	H	0.0	29.4	1.7	22.9	54
6003.125000	31.1	200.0	V	0.0	26.2	4.9	22.9	54
6906.875000	43.8	200.0	V	0.0	37.5	6.3	10.2	54
7360.625000	31.5	200.0	V	0.0	24.5	7.0	22.5	54

Remark: 1. Correction Factor = Antenna factor+ Insertion loss (cable loss + amplifier gain)

802.11a CH40

FCC RE 1G-3GHz PK+AV Class B

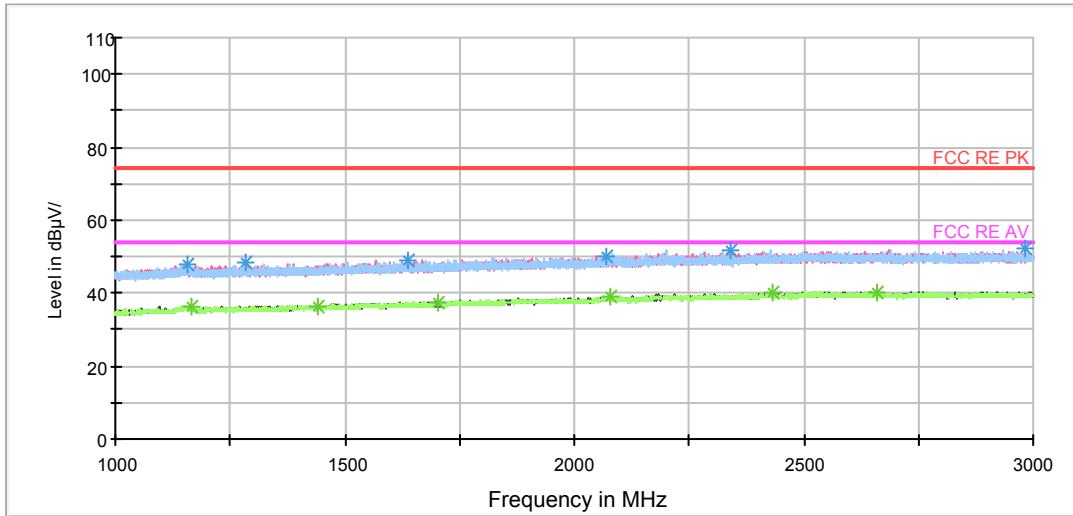

Radiates Emission from 1GHz to 3GHz

RE 3-18GHz PK+AV

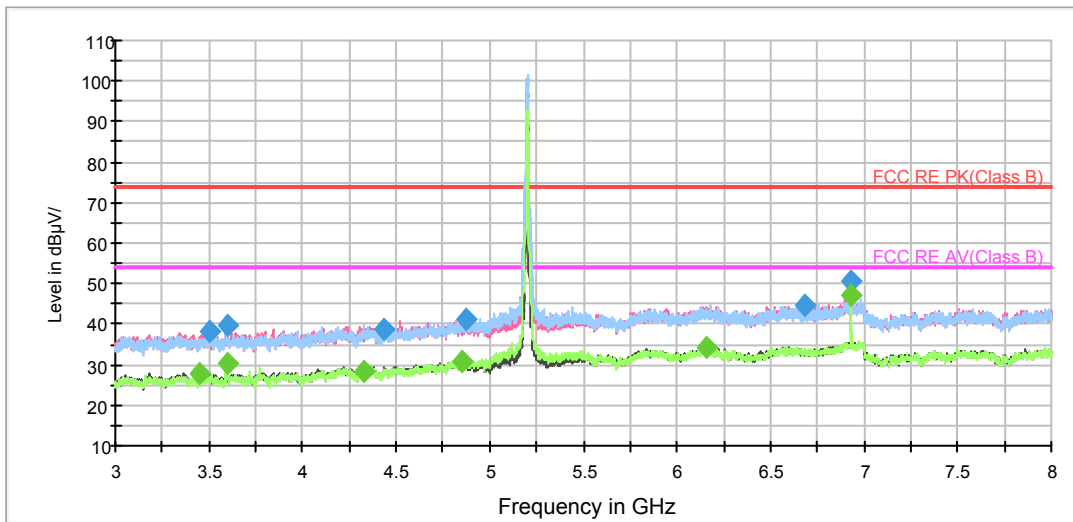

Note: The signal beyond the limit is carrier.

Radiates Emission from 3GHz to 8GHz

RE 3-18GHz PK+AV

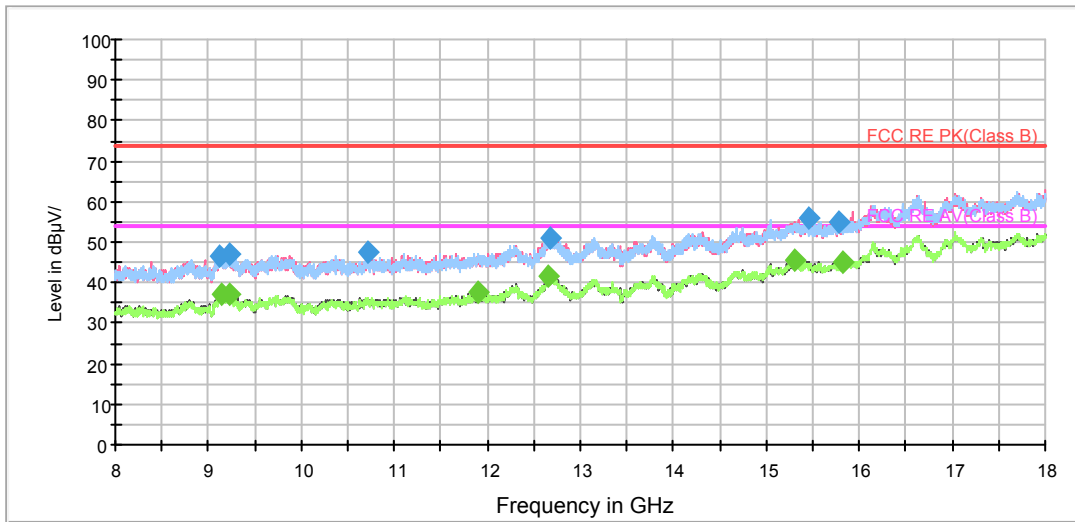

Radiates Emission from 8GHz to 18GHz

RE 18-26.5GHz PK+AV

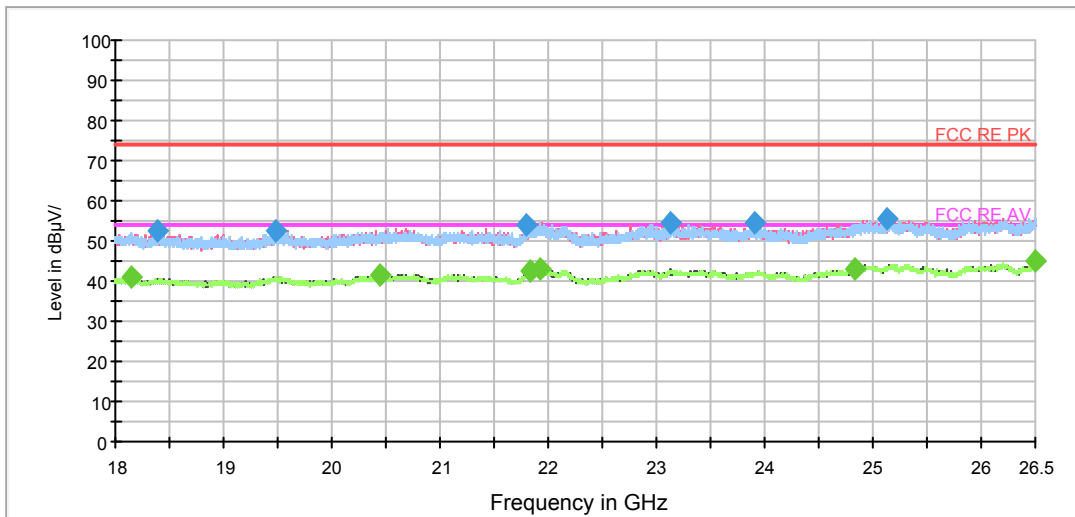

Radiates Emission from 18GHz to 26.5GHz

RE 26.5-40GHz PK+AV Class B



Radiates Emission from 26.5GHz to 40GHz

Frequency (MHz)	Peak (dBuV/m)	Height (cm)	Polarization	Azimuth (deg)	Reading value (dBuV/m)	Correct Factor (dB)	Margin (dB)	Limit (dBuV/m)
3501.250000	38.2	100.0	V	208.0	40.3	-2.1	35.8	74
3596.250000	39.6	100.0	H	12.0	41.9	-2.3	34.4	74
4435.000000	38.8	100.0	V	247.0	38.6	0.2	35.2	74
4875.000000	41.0	100.0	V	247.0	39.2	1.8	33.0	74
6680.000000	44.8	100.0	H	12.0	39.3	5.5	29.2	74
6933.750000	50.4	100.0	H	41.0	44.2	6.2	23.6	74

Remark: 1. Correction Factor = Antenna factor+ Insertion loss (cable loss + amplifier gain)

Frequency (MHz)	Average (dBuV/m)	Height (cm)	Polarization	Azimuth (deg)	Reading value (dBuV/m)	Correct Factor (dB)	Margin (dB)	Limit (dBuV/m)
3452.500000	27.7	100.0	V	355.0	29.9	-2.2	26.3	54
3594.375000	30.3	100.0	H	12.0	32.6	-2.3	23.7	54
4326.875000	28.1	100.0	V	247.0	27.6	0.5	25.9	54
4850.625000	30.9	100.0	H	0.0	29.3	1.6	23.1	54
6157.500000	34.3	100.0	H	56.0	28.7	5.6	19.7	54
6933.750000	47.1	100.0	H	41.0	40.9	6.2	6.9	54

Remark: 1. Correction Factor = Antenna factor+ Insertion loss (cable loss + amplifier gain)

802.11a CH48

FCC RE 1G-3GHz PK+AV Class B

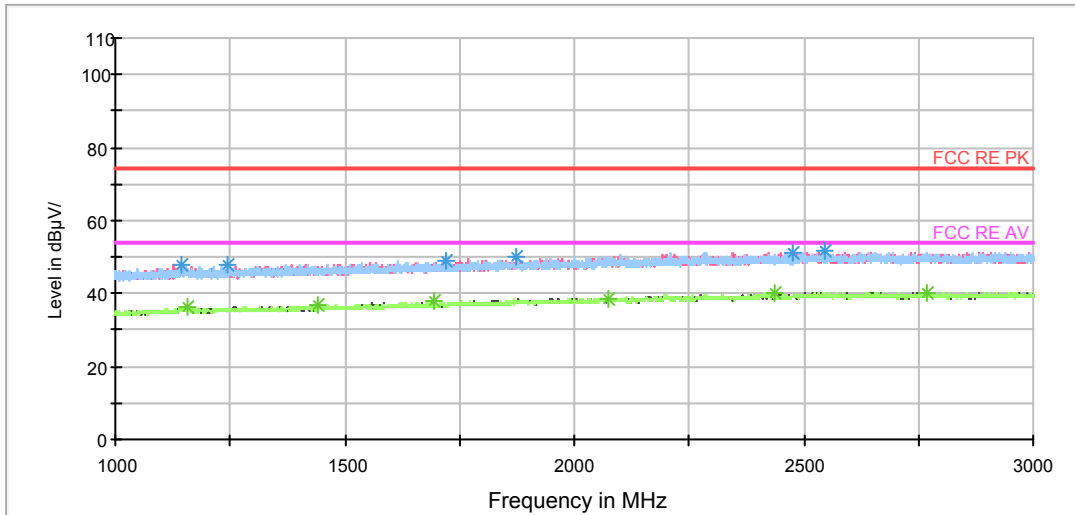

Radiates Emission from 1GHz to 3GHz

RE 3-18GHz PK+AV

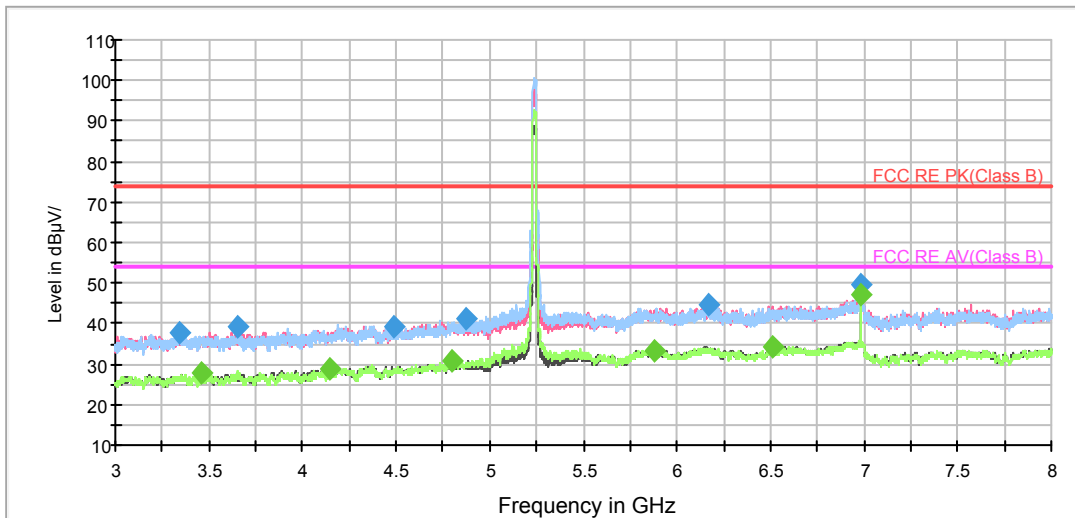

Note: The signal beyond the limit is carrier.

Radiates Emission from 3GHz to 8GHz

RE 3-18GHz PK+AV

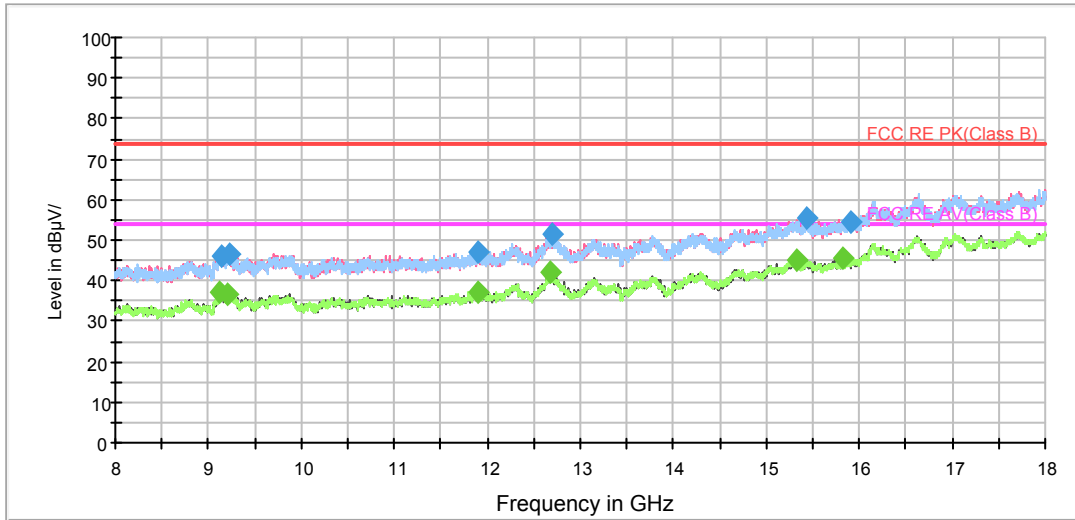

Radiates Emission from 8GHz to 18GHz

RE 18-26.5GHz PK+AV

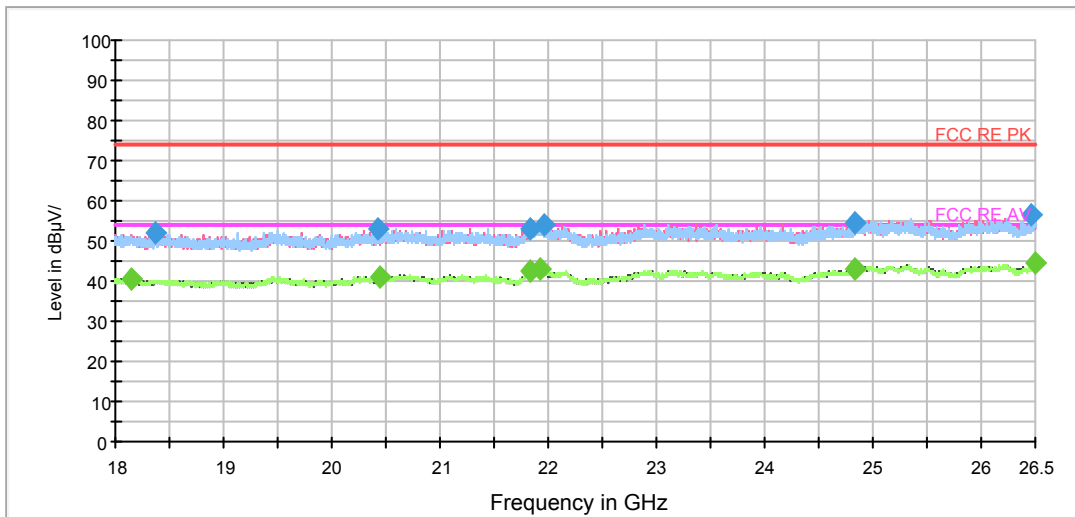

Radiates Emission from 18GHz to 26.5GHz

RE 26.5-40GHz PK+AV Class B

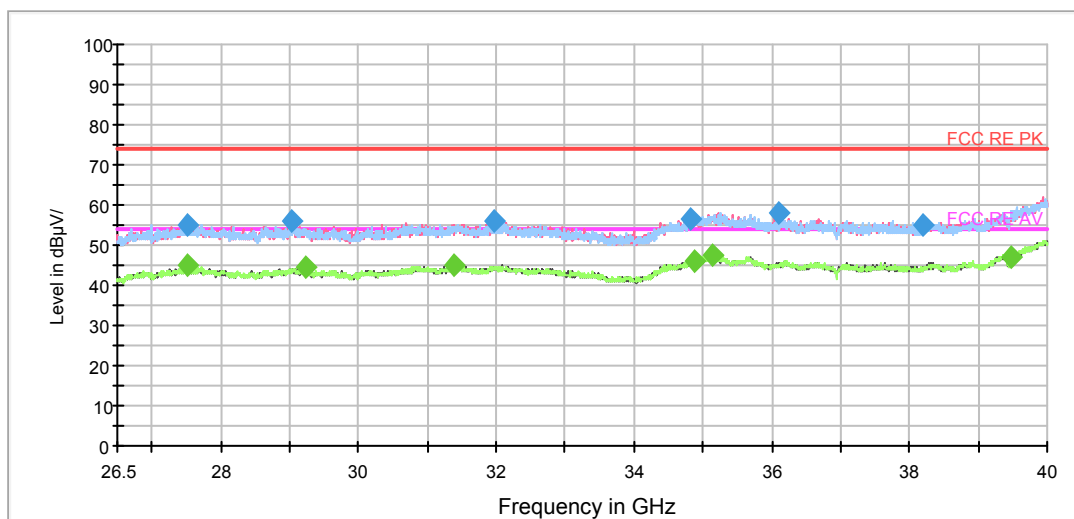

Radiates Emission from 26.5GHz to 40GHz

Frequency (MHz)	Peak (dBuV/m)	Height (cm)	Polarization	Azimuth (deg)	Reading value (dBuV/m)	Correct Factor (dB)	Margin (dB)	Limit (dBuV/m)
3346.875000	37.7	100.0	H	243.0	40.0	-2.3	36.3	74
3658.125000	39.1	100.0	H	0.0	41.0	-1.9	34.9	74
4490.000000	39.2	100.0	V	336.0	38.7	0.5	34.8	74
4873.125000	41.1	100.0	V	356.0	39.3	1.8	32.9	74
6170.625000	44.6	100.0	H	185.0	39.1	5.5	29.4	74
6986.875000	49.6	100.0	H	338.0	43.2	6.4	24.4	74

Remark: 1. Correction Factor = Antenna factor+ Insertion loss (cable loss + amplifier gain)

Frequency (MHz)	Average (dBuV/m)	Height (cm)	Polarization	Azimuth (deg)	Reading value (dBuV/m)	Correct Factor (dB)	Margin (dB)	Limit (dBuV/m)
3458.125000	27.6	100.0	V	327.0	1.2	26.4	26.4	54
4148.750000	28.6	100.0	V	248.0	3.2	25.4	25.4	54
4798.125000	30.9	100.0	H	185.0	7.8	23.1	23.1	54
5878.125000	33.1	100.0	V	208.0	12.2	20.9	20.9	54
6513.125000	34.3	100.0	V	144.0	14.6	19.7	19.7	54
6986.875000	47.2	100.0	H	338.0	40.4	6.8	6.8	54

Remark: 1. Correction Factor = Antenna factor+ Insertion loss (cable loss + amplifier gain)

802.11a CH52

FCC RE 1G-3GHz PK+AV Class B

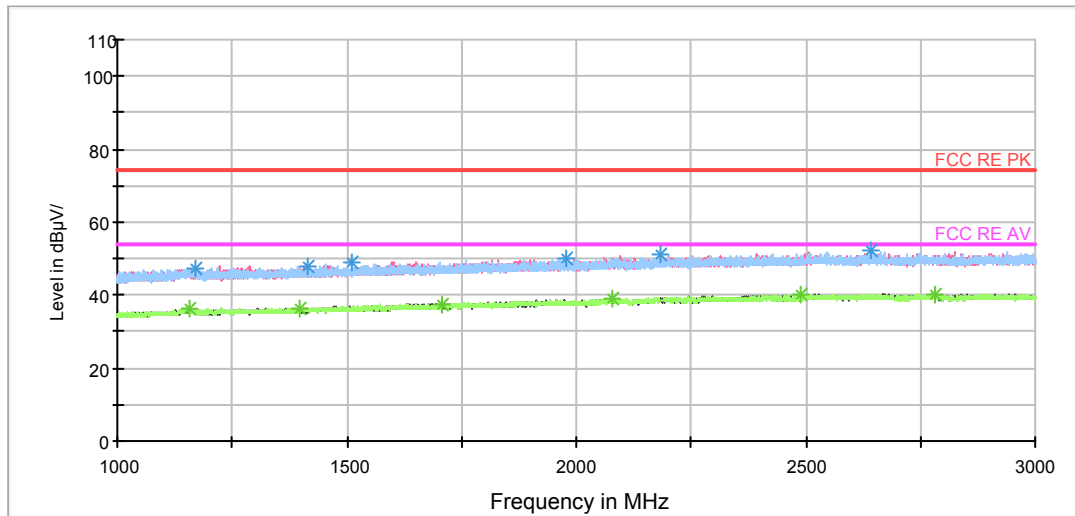

Radiates Emission from 1GHz to 3GHz

RE 3-18GHz PK+AV

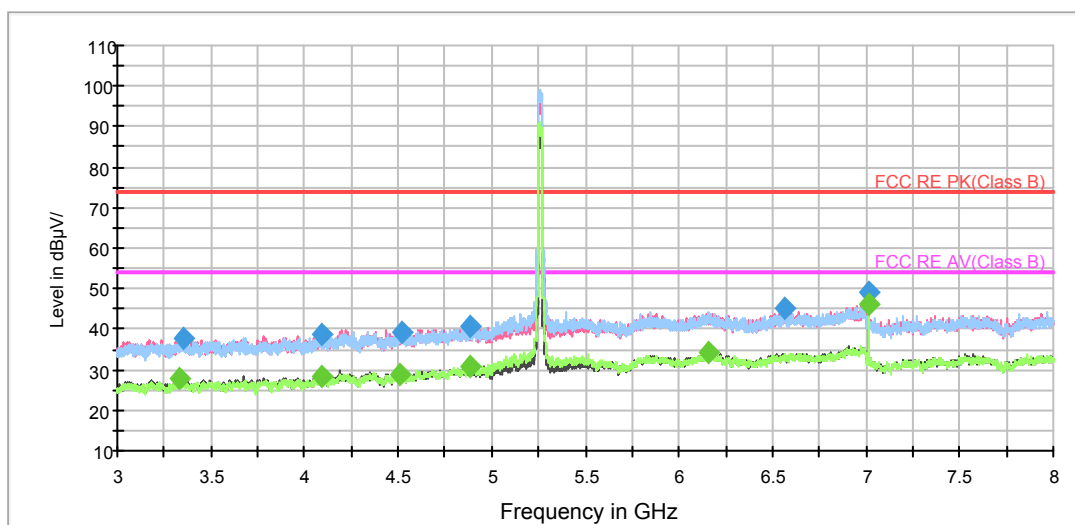

Note: The signal beyond the limit is carrier.

Radiates Emission from 3GHz to 8GHz

RE 3-18GHz PK+AV

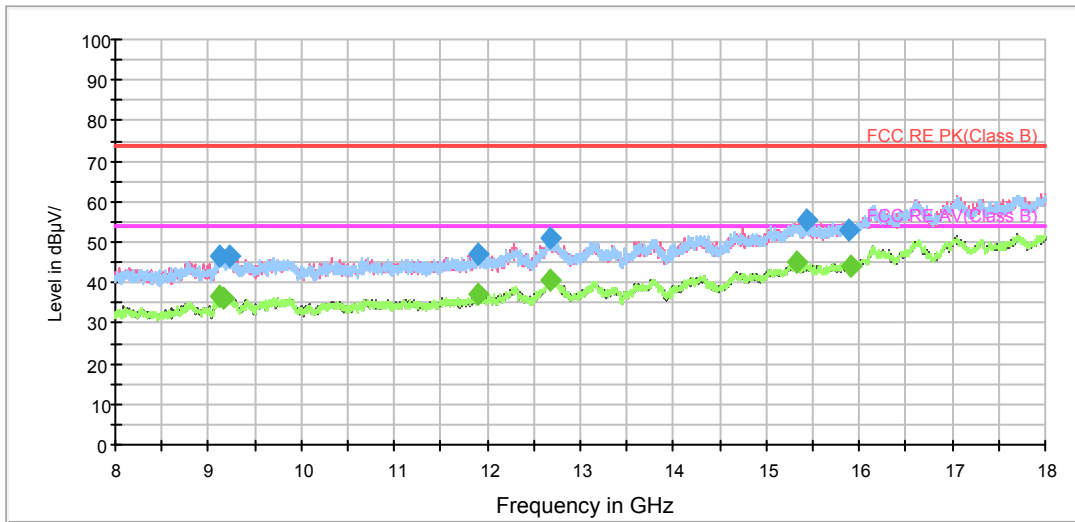

Radiates Emission from 8GHz to 18GHz

RE 18-26.5GHz PK+AV

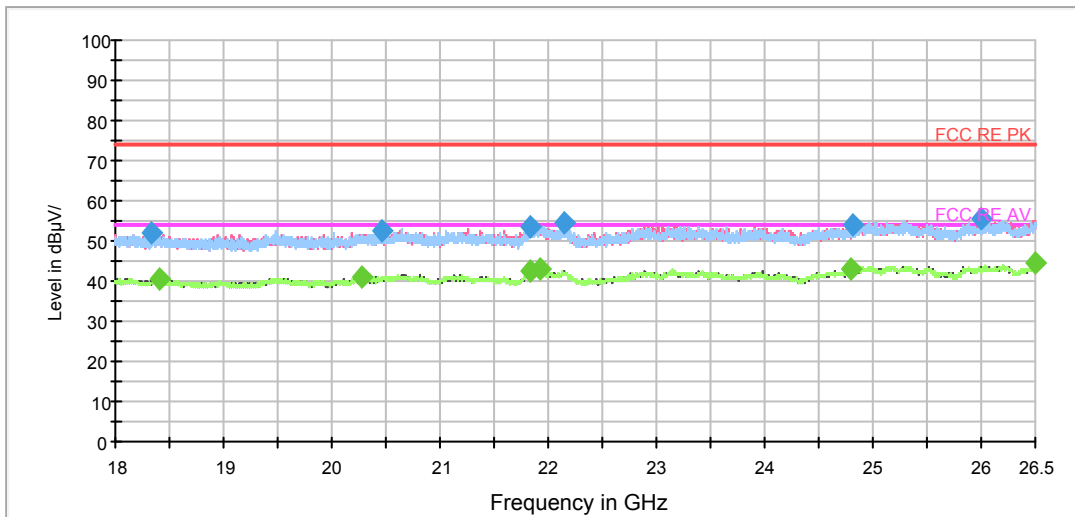

Radiates Emission from 18GHz to 26.5GHz

RE 26.5-40GHz PK+AV Class B

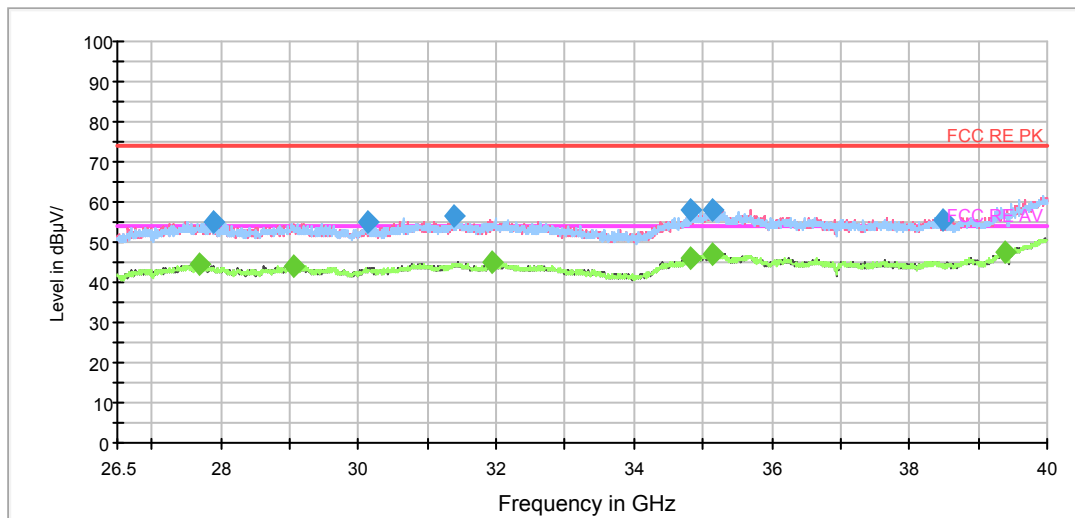

Radiates Emission from 26.5GHz to 40GHz

Frequency (MHz)	Peak (dBuV/m)	Height (cm)	Polarization	Azimuth (deg)	Reading value (dBuV/m)	Correct Factor (dB)	Margin (dB)	Limit (dBuV/m)
3353.750000	37.6	100.0	V	168.0	39.9	-2.3	36.4	74
4092.500000	38.7	100.0	V	277.0	39.6	-0.9	35.3	74
4516.875000	39.1	100.0	H	18.0	38.6	0.5	34.9	74
4881.875000	40.9	100.0	V	287.0	39.1	1.8	33.1	74
6567.500000	45.1	100.0	H	215.0	39.4	5.7	28.9	74
7013.750000	48.9	100.0	H	338.0	42.4	6.5	25.1	74

Remark: 1. Correction Factor = Antenna factor+ Insertion loss (cable loss + amplifier gain)

Frequency (MHz)	Average (dBuV/m)	Height (cm)	Polarization	Azimuth (deg)	Reading value (dBuV/m)	Correct Factor (dB)	Margin (dB)	Limit (dBuV/m)
3330.625000	27.7	100.0	V	359.0	29.9	-2.2	26.3	54
4093.750000	28.4	100.0	V	139.0	29.3	-0.9	25.6	54
4507.500000	28.9	100.0	V	139.0	28.4	0.5	25.1	54
4880.000000	30.5	100.0	H	8.0	28.7	1.8	23.5	54
6155.625000	34.3	100.0	V	0.0	28.7	5.6	19.7	54
7013.750000	45.9	100.0	H	338.0	39.4	6.5	8.1	54

Remark: 1. Correction Factor = Antenna factor+ Insertion loss (cable loss + amplifier gain)

802.11a CH60

FCC RE 1G-3GHz PK+AV Class B

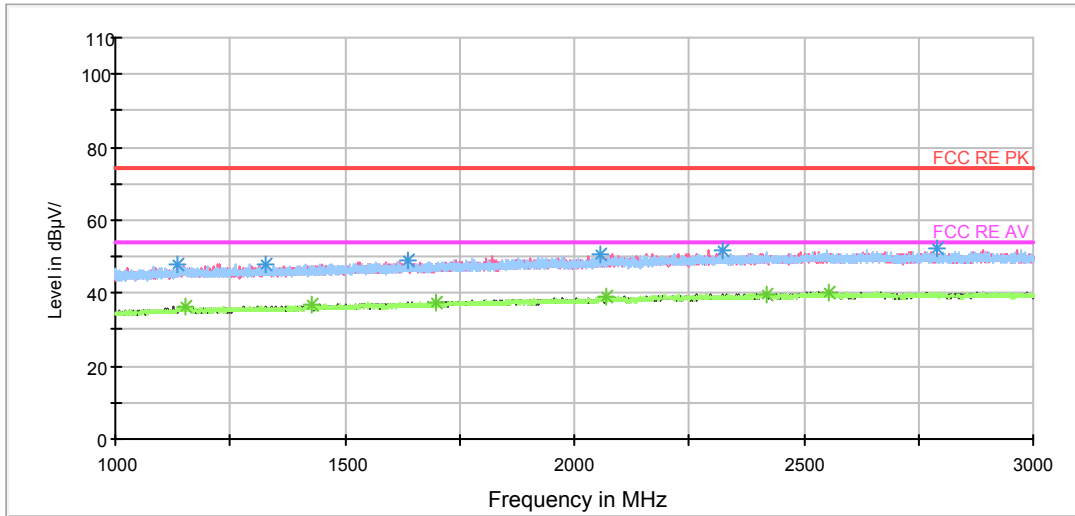

Radiates Emission from 1GHz to 3GHz

RE 3-18GHz PK+AV

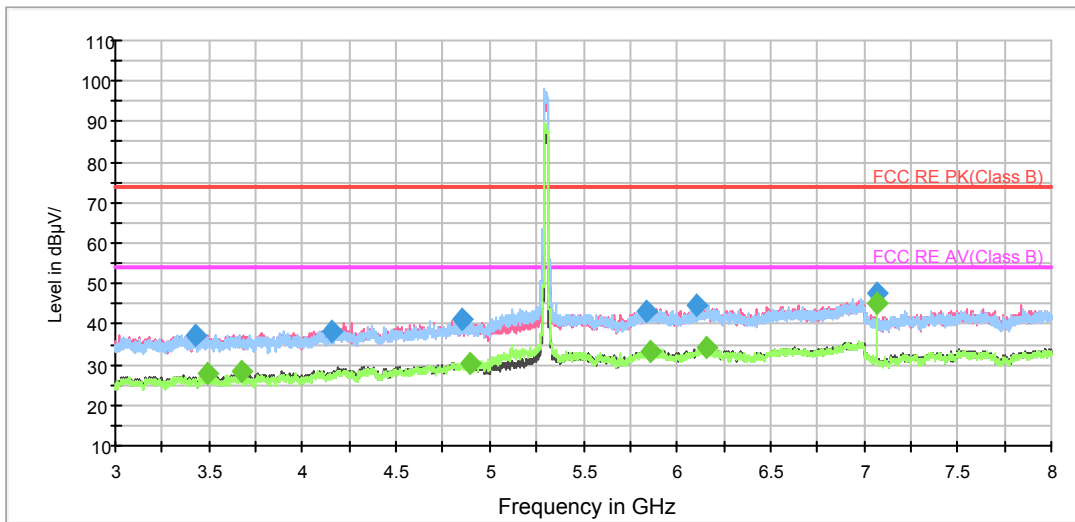

Note: The signal beyond the limit is carrier.

Radiates Emission from 3GHz to 8GHz

RE 3-18GHz PK+AV

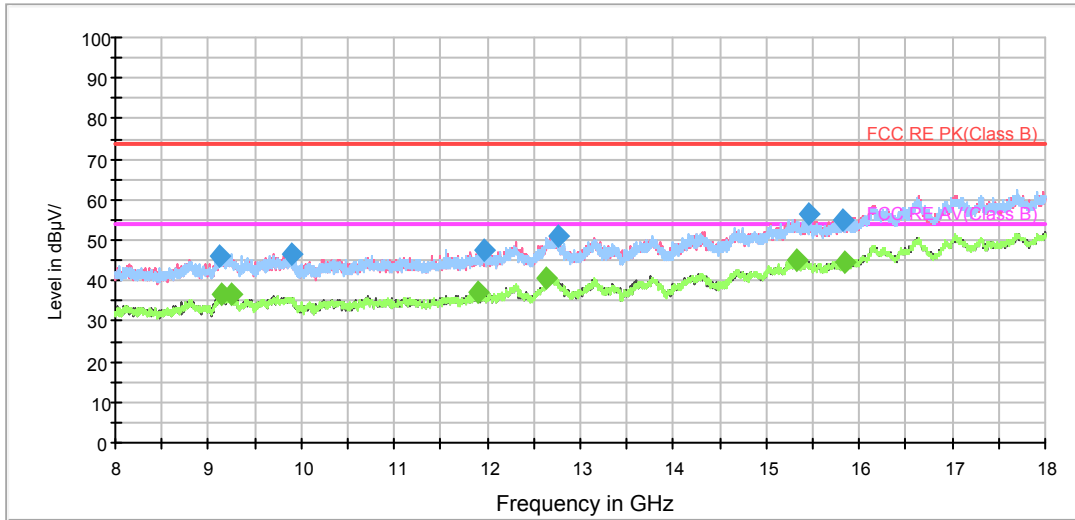

Radiates Emission from 8GHz to 18GHz

RE 18-26.5GHz PK+AV

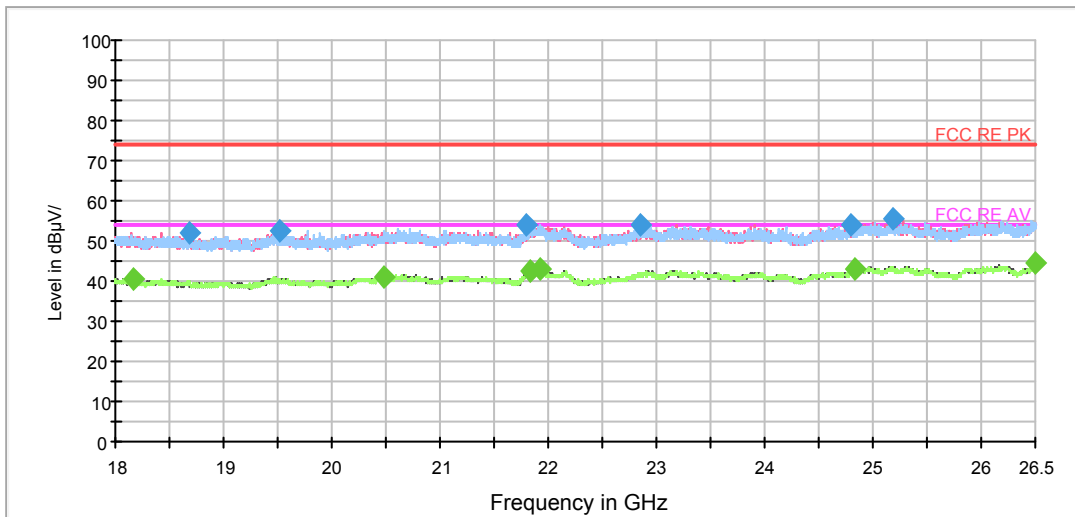

Radiates Emission from 18GHz to 26.5GHz



RE 26.5-40GHz PK+AV Class B

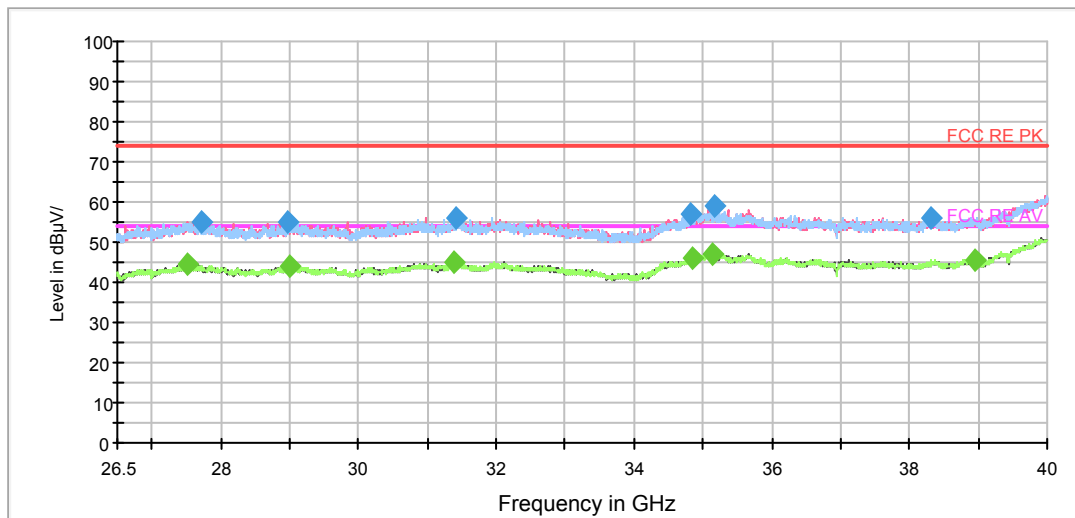

Radiates Emission from 26.5GHz to 40GHz

Frequency (MHz)	Peak (dBuV/m)	Height (cm)	Polarization	Azimuth (deg)	Reading value (dBuV/m)	Correct Factor (dB)	Margin (dB)	Limit (dBuV/m)
3431.875000	37.4	200.0	H	71.0	39.8	-2.4	36.6	74
4153.750000	38.2	200.0	H	81.0	38.3	-0.1	35.8	74
4853.125000	41.2	200.0	H	51.0	39.6	1.6	32.8	74
5839.375000	43.0	200.0	V	342.0	38.5	4.5	31.0	74
6106.250000	44.6	200.0	V	342.0	39.4	5.2	29.4	74
7066.875000	47.5	200.0	H	71.0	41.3	6.2	26.5	74

Remark: 1. Correction Factor = Antenna factor+ Insertion loss (cable loss + amplifier gain)

Frequency (MHz)	Average (dBuV/m)	Height (cm)	Polarization	Azimuth (deg)	Reading value (dBuV/m)	Correct Factor (dB)	Margin (dB)	Limit (dBuV/m)
3495.625000	27.7	200.0	V	254.0	29.8	-2.1	26.3	54
3675.625000	28.6	200.0	H	295.0	30.4	-1.8	25.4	54
4891.250000	30.3	200.0	H	0.0	28.4	1.9	23.7	54
5858.125000	33.2	200.0	V	195.0	28.4	4.8	20.8	54
6156.250000	34.1	200.0	V	342.0	28.5	5.6	19.9	54
7066.875000	45.1	200.0	H	71.0	38.9	6.2	8.9	54

Remark: 1. Correction Factor = Antenna factor+ Insertion loss (cable loss + amplifier gain)

802.11a CH64

FCC RE 1G-3GHz PK+AV Class B

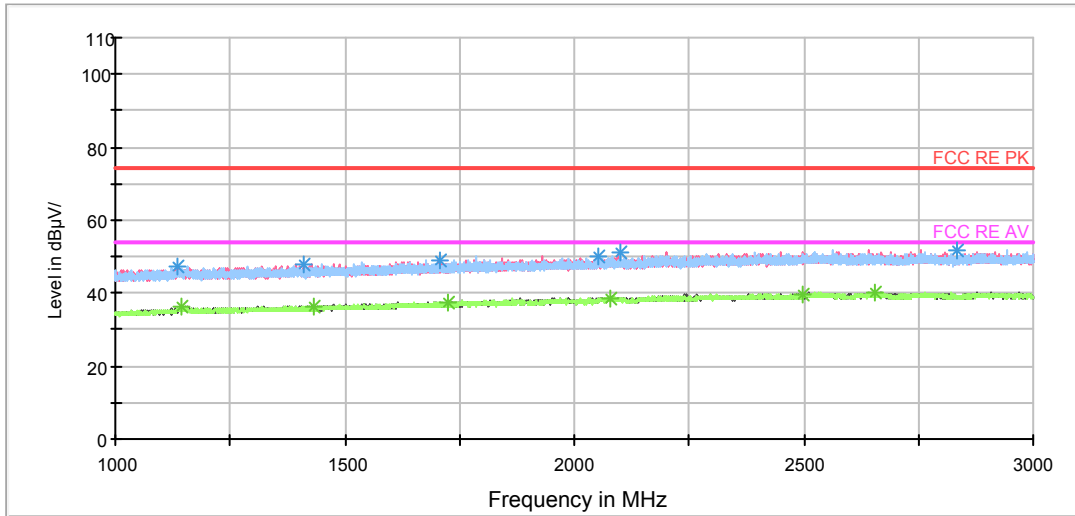

Radiates Emission from 1GHz to 3GHz

RE 3-18GHz PK+AV

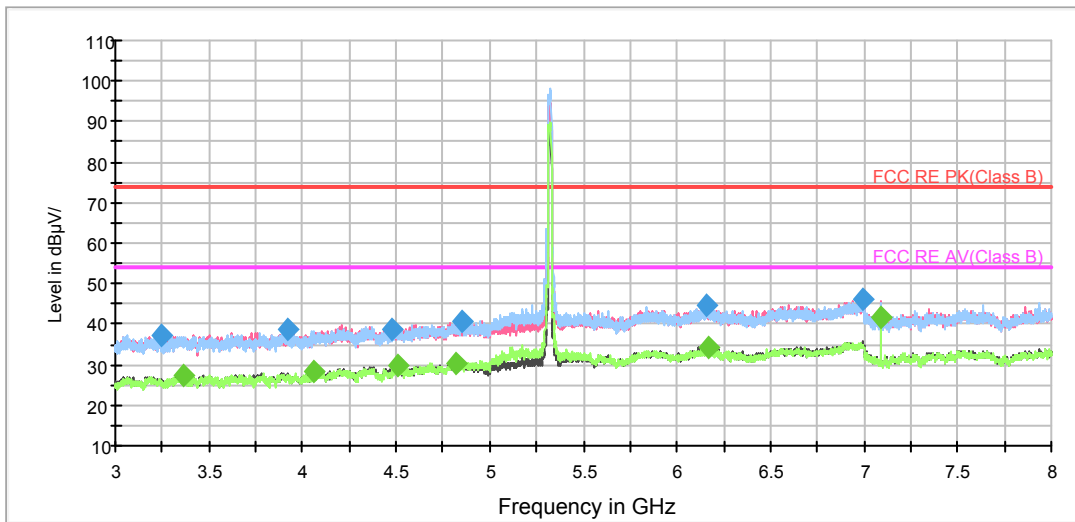

Note: The signal beyond the limit is carrier.

Radiates Emission from 3GHz to 8GHz

RE 3-18GHz PK+AV

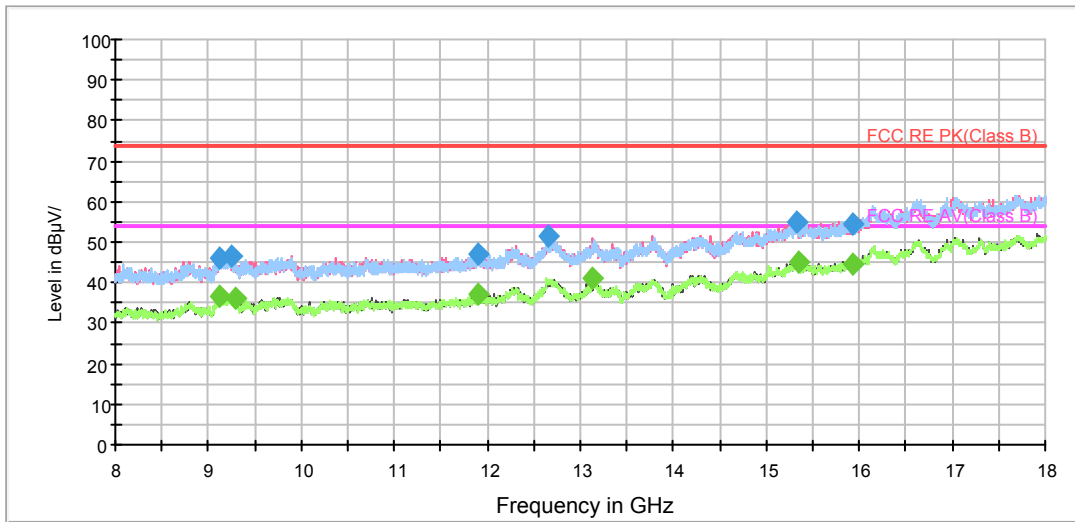

Radiates Emission from 8GHz to 18GHz

RE 18-26.5GHz PK+AV

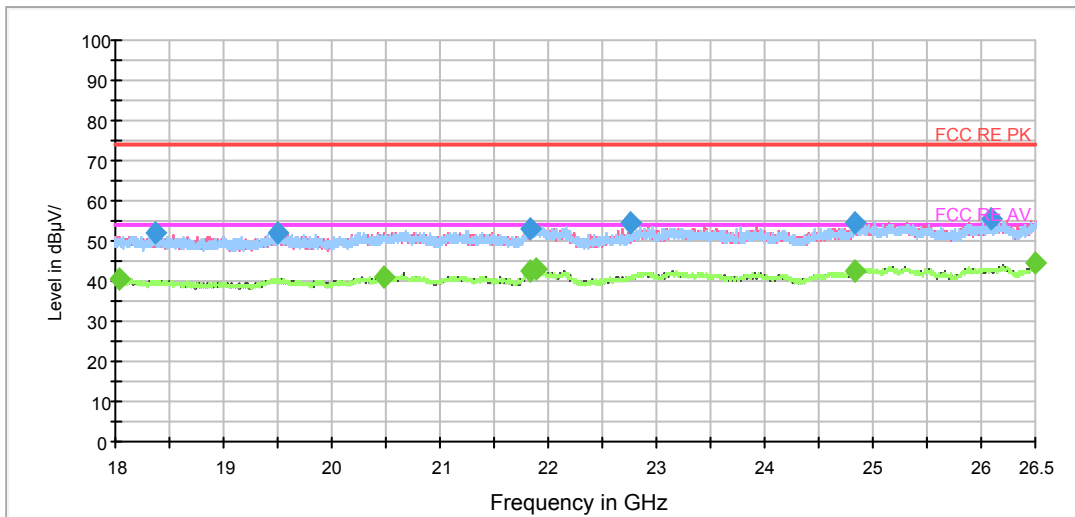

Radiates Emission from 18GHz to 26.5GHz

RE 26.5-40GHz PK+AV Class B



Radiates Emission from 26.5GHz to 40GHz

Frequency (MHz)	Peak (dBuV/m)	Height (cm)	Polarization	Azimuth (deg)	Reading value (dBuV/m)	Correct Factor (dB)	Margin (dB)	Limit (dBuV/m)
3245.625000	37.4	200.0	V	240.0	40.0	-2.6	36.6	74
3924.375000	38.6	200.0	V	49.0	39.8	-1.2	35.4	74
4477.500000	38.5	200.0	V	279.0	38.0	0.5	35.5	74
4857.500000	40.7	200.0	H	12.0	39.0	1.7	33.3	74
6158.125000	44.8	200.0	H	228.0	39.2	5.6	29.2	74
6998.750000	46.3	200.0	V	259.0	39.8	6.5	27.7	74

Remark: 1. Correction Factor = Antenna factor+ Insertion loss (cable loss + amplifier gain)

Frequency (MHz)	Average (dBuV/m)	Height (cm)	Polarization	Azimuth (deg)	Reading value (dBuV/m)	Correct Factor (dB)	Margin (dB)	Limit (dBuV/m)
3366.875000	27.4	200.0	V	328.0	29.8	-2.4	26.6	54
4056.250000	28.3	200.0	V	357.0	29.4	-1.1	25.7	54
4504.375000	29.7	200.0	V	328.0	29.2	0.5	24.3	54
4822.500000	30.4	200.0	V	179.0	29.1	1.3	23.6	54
6166.250000	34.2	200.0	V	160.0	28.6	5.6	19.8	54
7093.750000	41.6	200.0	V	0.0	35.5	6.1	12.4	54

Remark: 1. Correction Factor = Antenna factor+ Insertion loss (cable loss + amplifier gain)



802.11a CH100

FCC RE 1G-3GHz PK+AV Class B

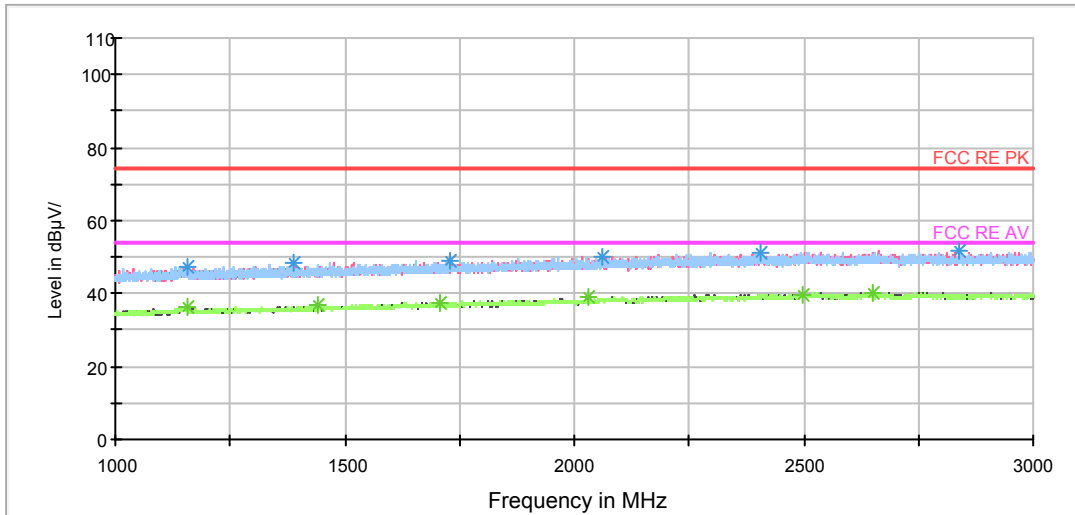

Radiates Emission from 1GHz to 3GHz

RE 3-18GHz PK+AV

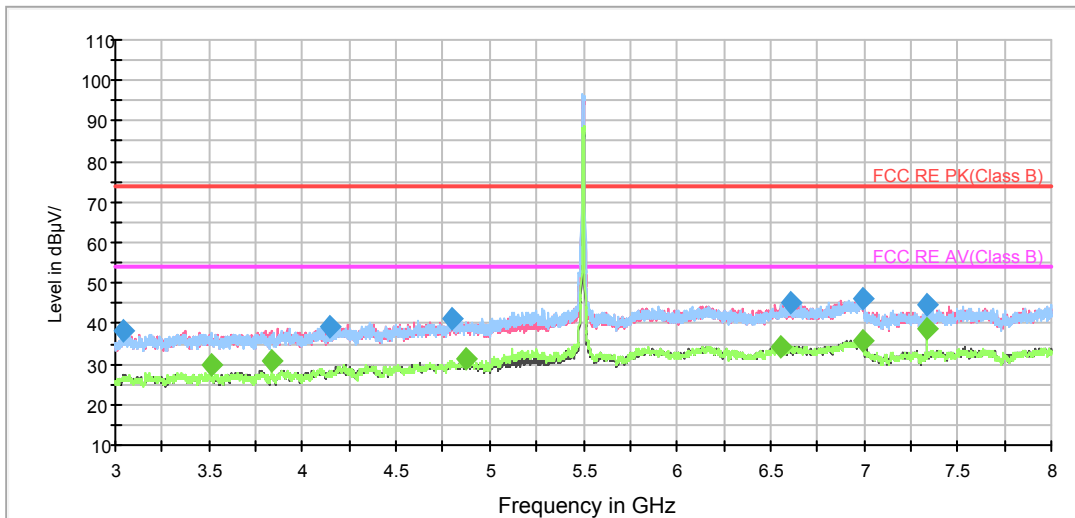

Note: The signal beyond the limit is carrier.

Radiates Emission from 3GHz to 8GHz

RE 3-18GHz PK+AV

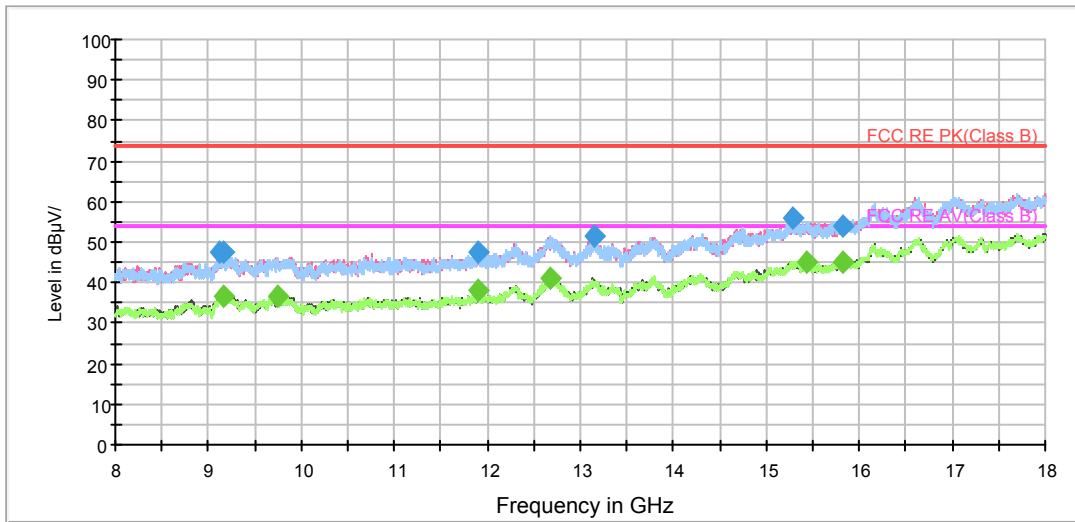

Radiates Emission from 8GHz to 18GHz

RE 18-26.5GHz PK+AV

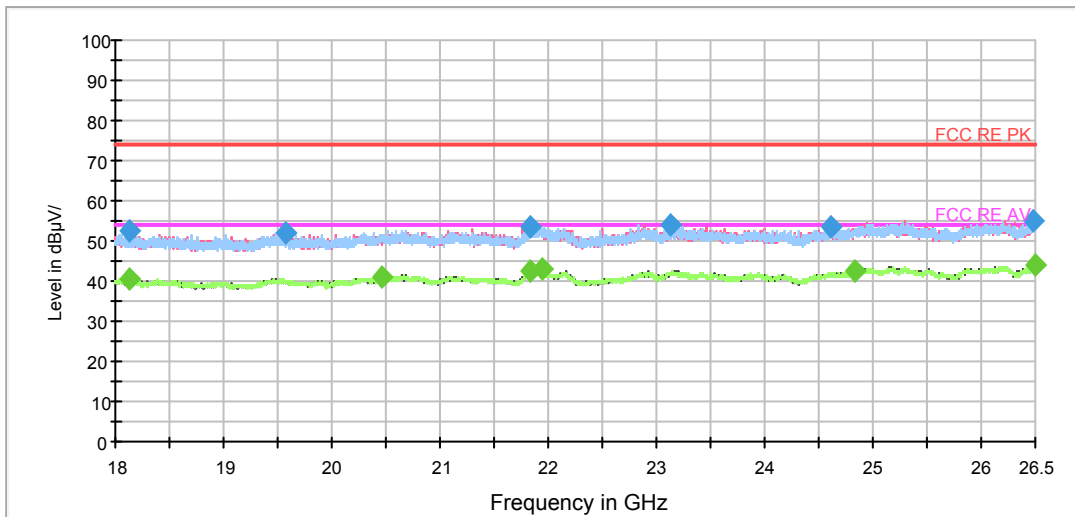

Radiates Emission from 18GHz to 26.5GHz

RE 26.5-40GHz PK+AV Class B

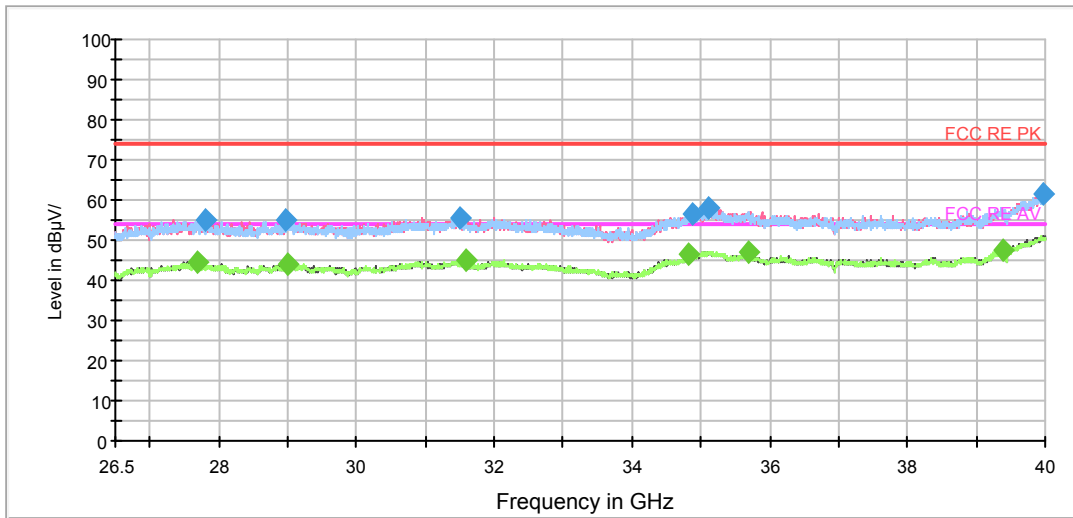

Radiates Emission from 26.5GHz to 40GHz

Frequency (MHz)	Peak (dBuV/m)	Height (cm)	Polarization	Azimuth (deg)	Reading value (dBuV/m)	Correct Factor (dB)	Margin (dB)	Limit (dBuV/m)
3047.500000	38.3	200.0	V	281.0	41.5	-3.2	35.7	74
4142.500000	39.0	200.0	H	0.0	39.2	-0.2	35.0	74
4796.250000	41.0	200.0	V	34.0	39.8	1.2	33.0	74
6605.625000	45.0	200.0	H	93.0	39.4	5.6	29.0	74
6996.875000	46.0	200.0	V	0.0	39.5	6.5	28.0	74
7333.125000	44.8	200.0	H	142.0	37.8	7.0	29.2	74

Remark: 1. Correction Factor = Antenna factor+ Insertion loss (cable loss + amplifier gain)

Frequency (MHz)	Average (dBuV/m)	Height (cm)	Polarization	Azimuth (deg)	Reading value (dBuV/m)	Correct Factor (dB)	Margin (dB)	Limit (dBuV/m)
3510.000000	29.9	200.0	H	0.0	31.9	-2.0	24.1	54
3837.500000	30.7	200.0	H	163.0	32.4	-1.7	23.3	54
4876.250000	31.1	200.0	V	354.0	29.3	1.8	22.9	54
6555.625000	34.4	200.0	V	271.0	28.7	5.7	19.6	54
6992.500000	35.7	200.0	H	133.0	29.2	6.5	18.3	54
7333.750000	38.6	200.0	H	142.0	31.6	7.0	15.4	54

Remark: 1. Correction Factor = Antenna factor+ Insertion loss (cable loss + amplifier gain)

802.11a CH116

FCC RE 1G-3GHz PK+AV Class B

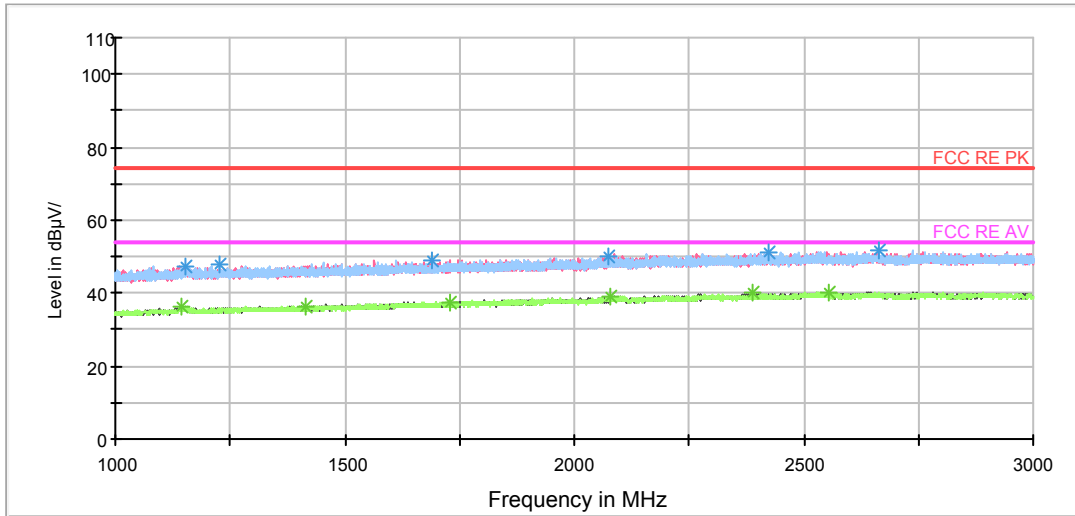

Radiates Emission from 1GHz to 3GHz

RE 3-18GHz PK+AV

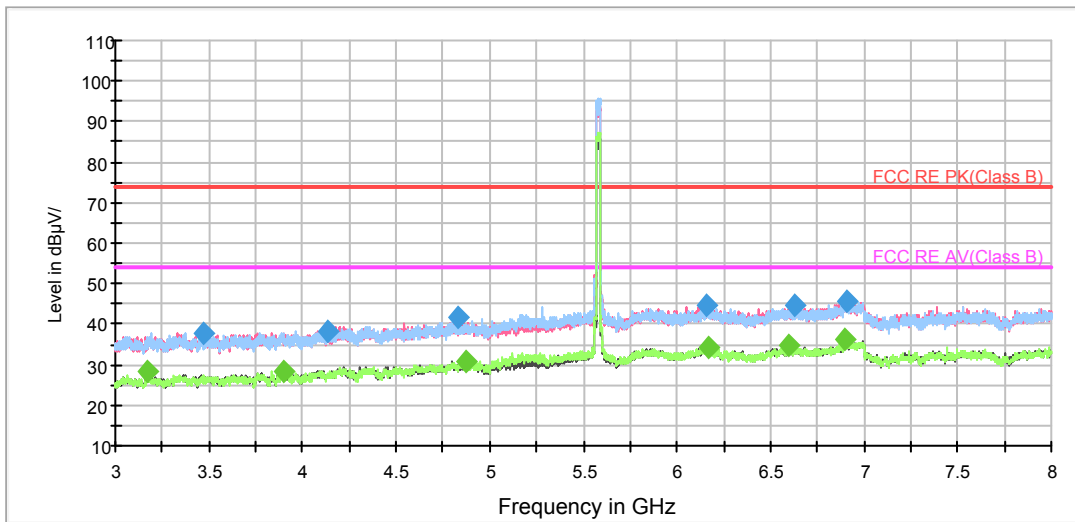

Note: The signal beyond the limit is carrier.

Radiates Emission from 3GHz to 8GHz

RE 3-18GHz PK+AV

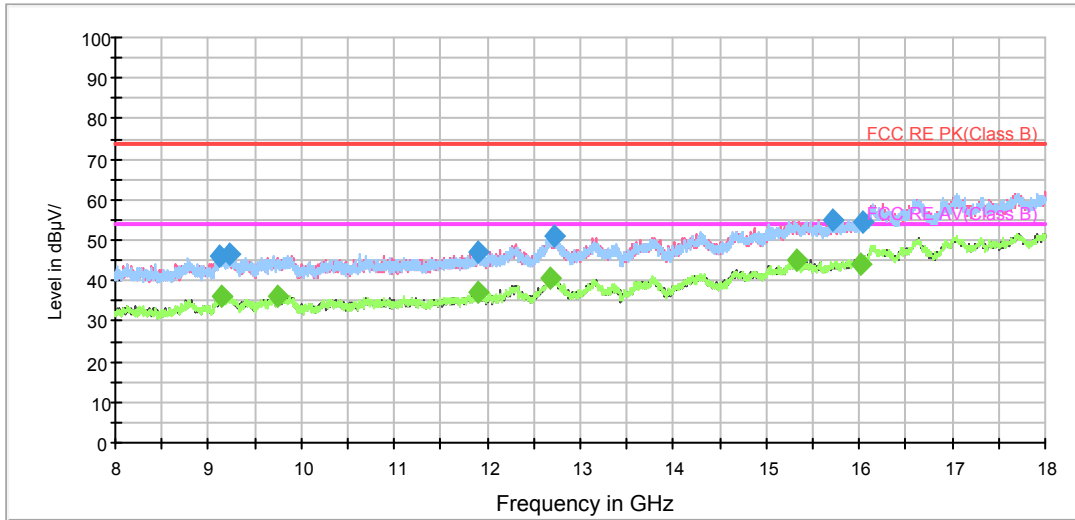

Radiates Emission from 8GHz to 18GHz

RE 18-26.5GHz PK+AV

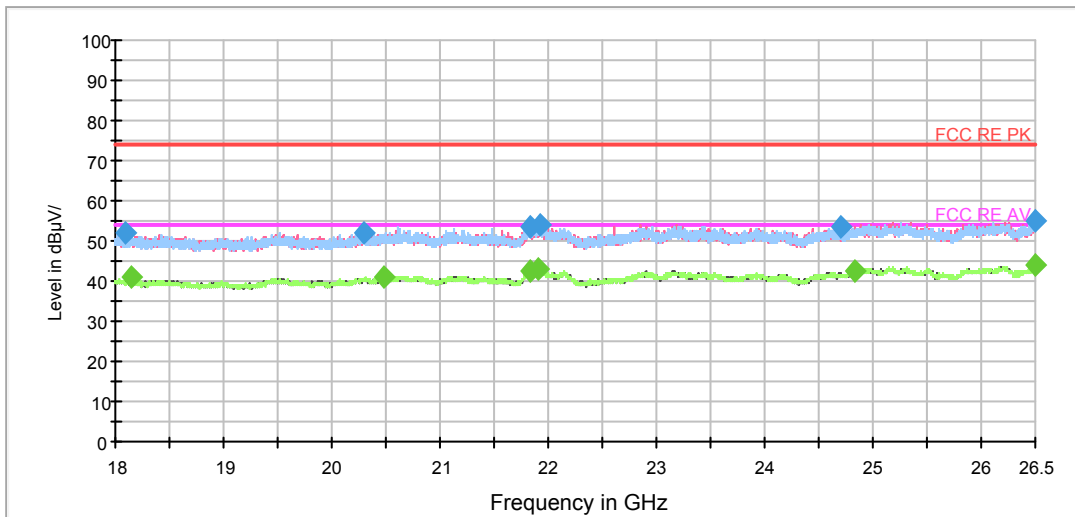

Radiates Emission from 18GHz to 26.5GHz

RE 26.5-40GHz PK+AV Class B



Radiates Emission from 26.5GHz to 40GHz

Frequency (MHz)	Peak (dBuV/m)	Height (cm)	Polarization	Azimuth (deg)	Reading value (dBuV/m)	Correct Factor (dB)	Margin (dB)	Limit (dBuV/m)
3466.875000	37.6	200.0	H	61.0	39.7	-2.1	36.4	74
4138.125000	38.3	200.0	H	111.0	38.6	-0.3	35.7	74
4833.125000	41.6	200.0	H	0.0	40.1	1.5	32.4	74
6158.750000	44.9	200.0	H	0.0	39.2	5.7	29.1	74
6627.500000	44.7	200.0	V	326.0	39.2	5.5	29.3	74
6903.750000	45.6	200.0	H	23.0	39.3	6.3	28.4	74

Remark: 1. Correction Factor = Antenna factor+ Insertion loss (cable loss + amplifier gain)

Frequency (MHz)	Average (dBuV/m)	Height (cm)	Polarization	Azimuth (deg)	Reading value (dBuV/m)	Correct Factor (dB)	Margin (dB)	Limit (dBuV/m)
3172.500000	28.5	200.0	H	71.0	31.4	-2.9	25.5	54
3896.875000	28.4	200.0	H	111.0	29.7	-1.3	25.6	54
4869.375000	30.7	200.0	H	0.0	28.9	1.8	23.3	54
6165.625000	34.4	200.0	V	0.0	28.8	5.6	19.6	54
6598.750000	34.5	200.0	V	316.0	28.8	5.7	19.5	54
6897.500000	36.1	200.0	V	208.0	29.9	6.2	17.9	54

Remark: 1. Correction Factor = Antenna factor+ Insertion loss (cable loss + amplifier gain)

802.11a CH140

FCC RE 1G-3GHz PK+AV Class B

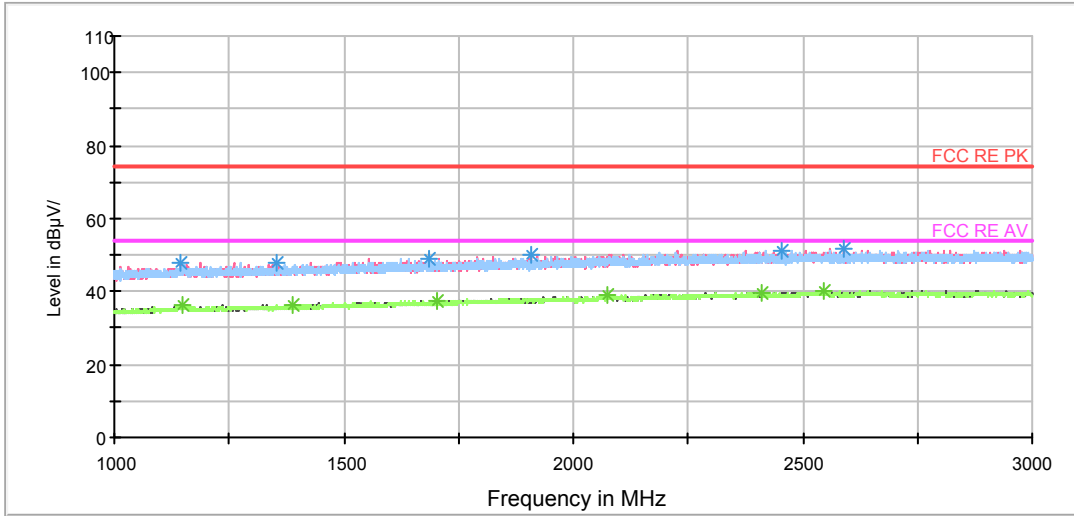

Radiates Emission from 1GHz to 3GHz

RE 3-18GHz PK+AV

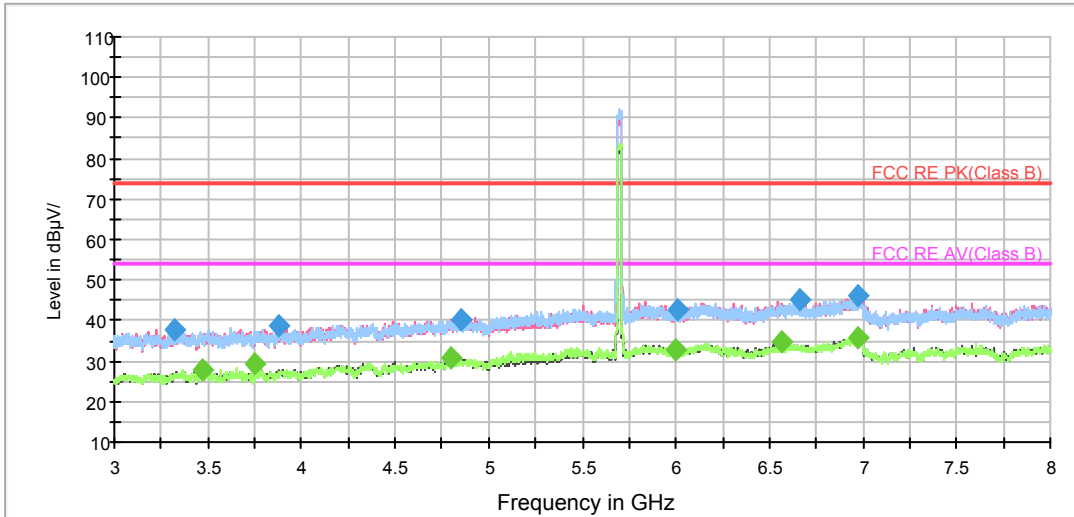

Note: The signal beyond the limit is carrier.

Radiates Emission from 3GHz to 8GHz

RE 3-18GHz PK+AV

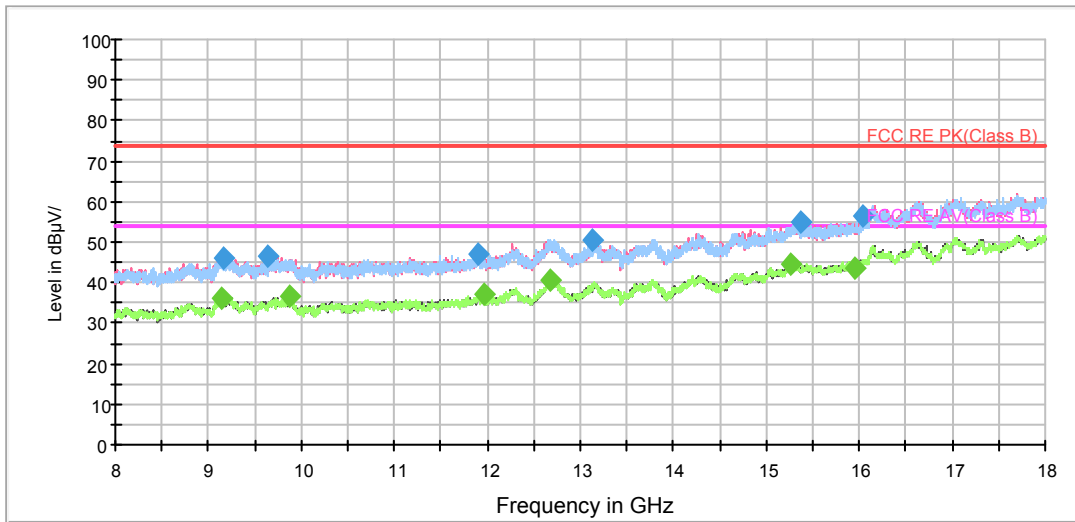

Radiates Emission from 8GHz to 18GHz

RE 18-26.5GHz PK+AV

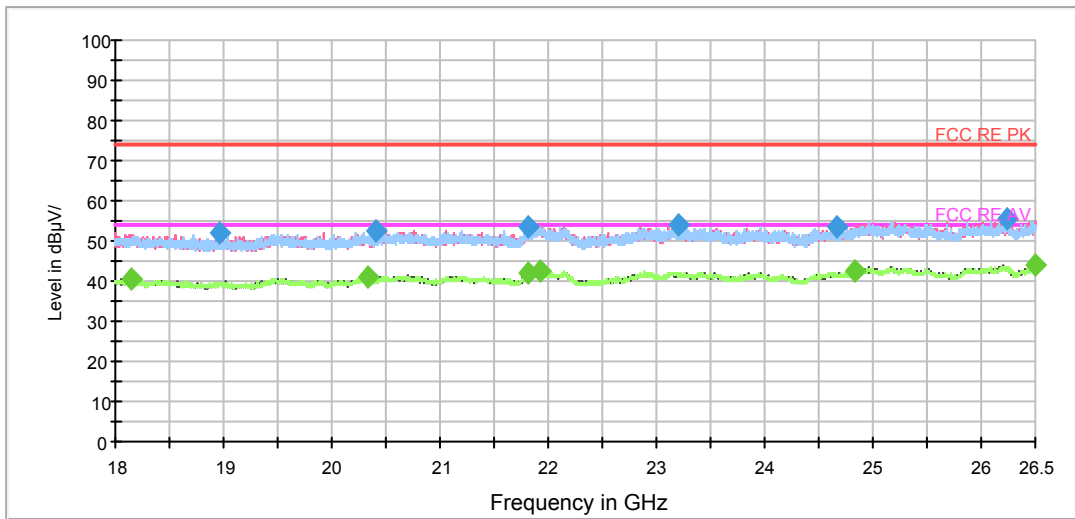

Radiates Emission from 18GHz to 26.5GHz

RE 26.5-40GHz PK+AV Class B

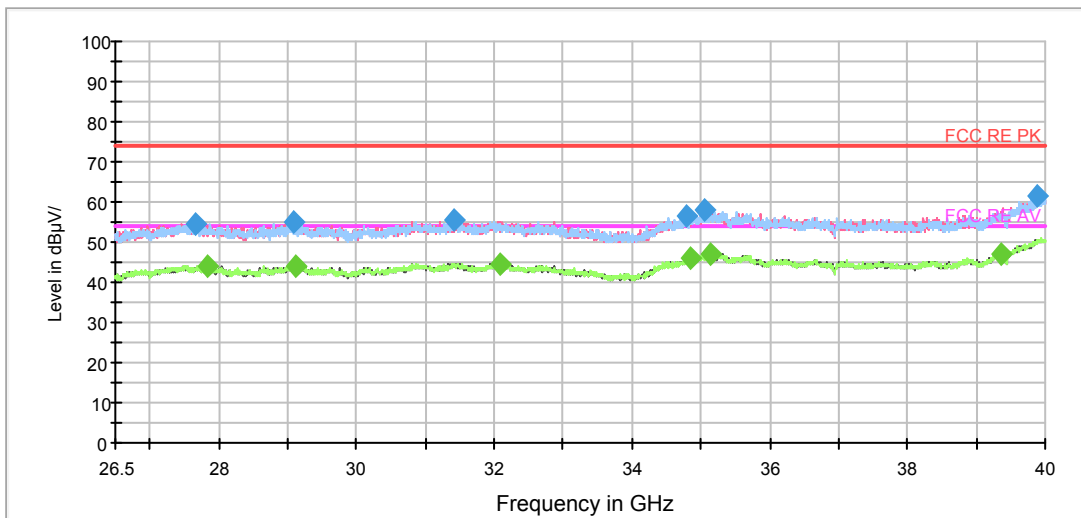

Radiates Emission from 26.5GHz to 40GHz

Frequency (MHz)	Peak (dBuV/m)	Height (cm)	Polarization	Azimuth (deg)	Reading value (dBuV/m)	Correct Factor (dB)	Margin (dB)	Limit (dBuV/m)
3316.875000	37.8	200.0	H	44.0	39.9	-2.1	36.2	74
3880.000000	38.5	200.0	H	0.0	39.8	-1.3	35.5	74
4851.875000	40.3	200.0	V	180.0	38.7	1.6	33.7	74
6005.625000	42.5	200.0	V	260.0	37.7	4.8	31.5	74
6665.000000	45.1	200.0	H	351.0	39.6	5.5	28.9	74
6973.125000	46.2	200.0	V	318.0	39.9	6.3	27.8	74

Remark: 1. Correction Factor = Antenna factor+ Insertion loss (cable loss + amplifier gain)

Frequency (MHz)	Average (dBuV/m)	Height (cm)	Polarization	Azimuth (deg)	Reading value (dBuV/m)	Correct Factor (dB)	Margin (dB)	Limit (dBuV/m)
3466.875000	27.7	200.0	V	201.0	29.8	-2.1	26.3	54
3750.000000	29.3	200.0	H	263.0	31.0	-1.7	24.7	54
4800.000000	30.6	200.0	H	0.0	29.3	1.3	23.4	54
5996.250000	33.0	200.0	H	273.0	28.1	4.9	21.0	54
6561.250000	34.5	200.0	H	327.0	28.7	5.8	19.5	54
6970.625000	35.7	200.0	V	0.0	29.4	6.3	18.3	54

Remark: 1. Correction Factor = Antenna factor+ Insertion loss (cable loss + amplifier gain)

802.11a CH149

FCC RE 1G-3GHz PK+AV Class B

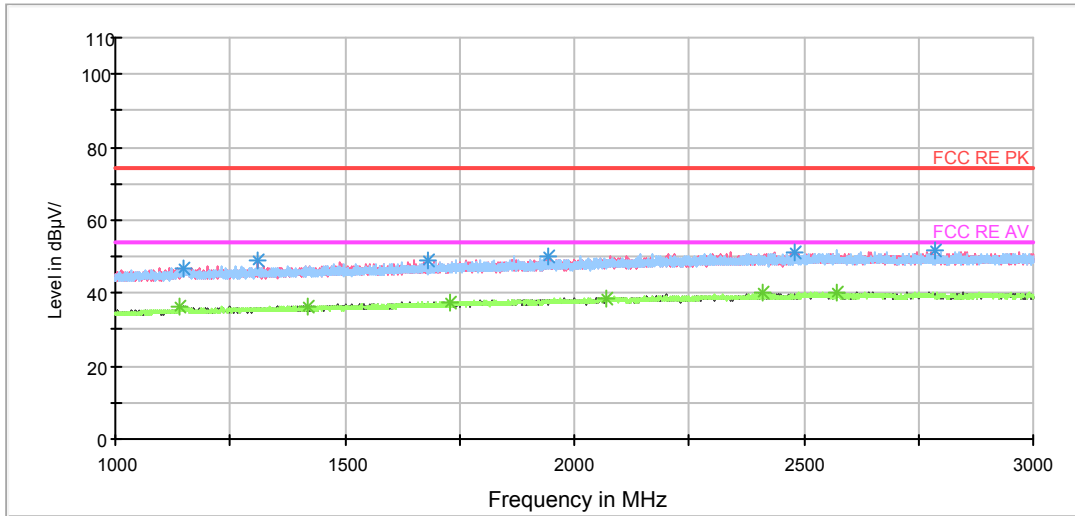

Radiates Emission from 1GHz to 3GHz

RE 3-18GHz PK+AV

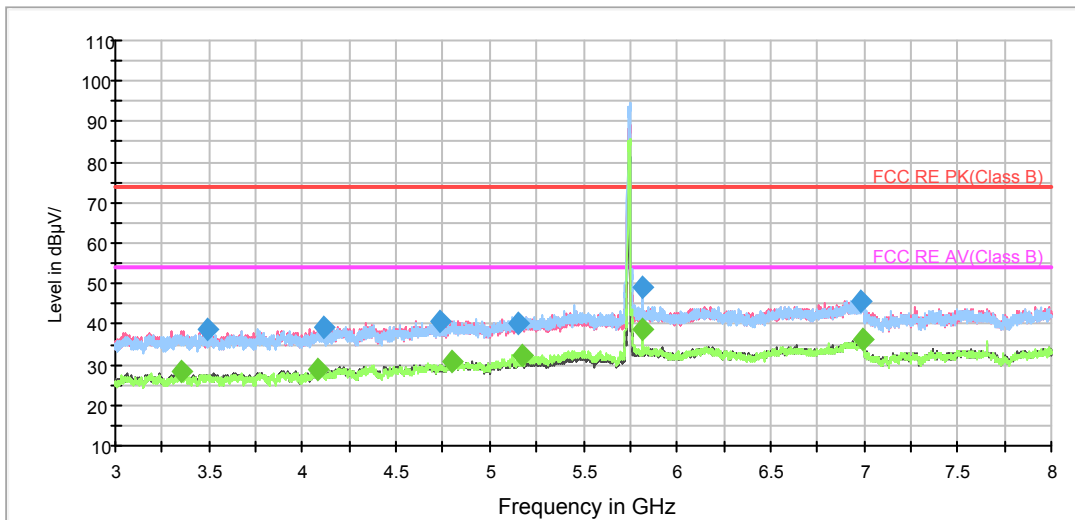

Note: The signal beyond the limit is carrier.

Radiates Emission from 3GHz to 8GHz

RE 3-18GHz PK+AV

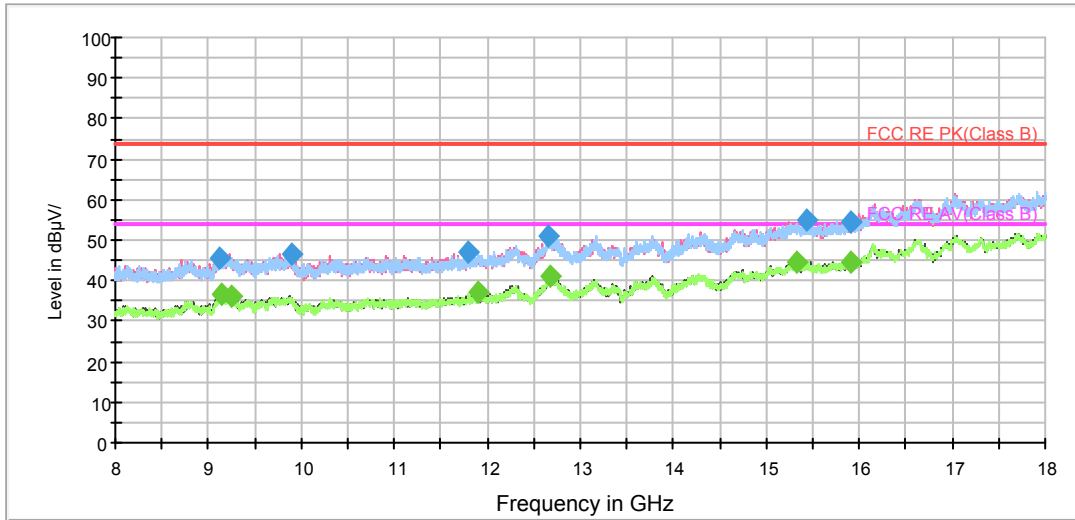

Radiates Emission from 8GHz to 18GHz

RE 18-26.5GHz PK+AV

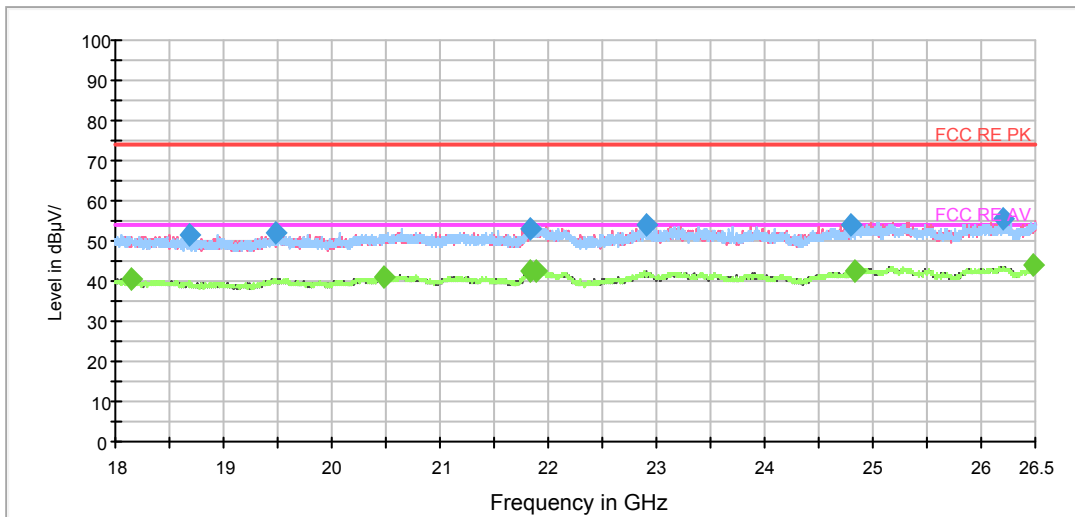

Radiates Emission from 18GHz to 26.5GHz

RE 26.5-40GHz PK+AV Class B

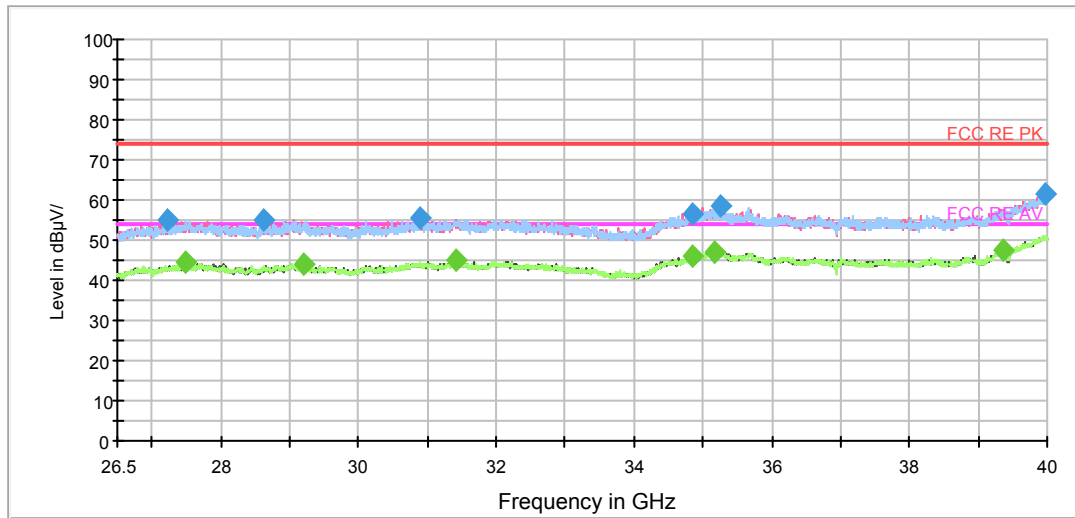

Radiates Emission from 26.5GHz to 40GHz

Frequency (MHz)	Peak (dBuV/m)	Height (cm)	Polarization	Azimuth (deg)	Reading value (dBuV/m)	Correct Factor (dB)	Margin (dB)	Limit (dBuV/m)
3487.500000	38.5	200.0	V	272.0	40.5	-2.0	35.5	74
4109.375000	39.4	200.0	H	162.0	40.1	-0.7	34.6	74
4739.375000	40.7	200.0	H	0.0	39.9	0.8	33.3	74
5155.000000	40.3	200.0	V	0.0	38.3	2.0	33.7	74
5811.875000	48.9	200.0	H	83.0	44.5	4.4	25.1	74
6980.000000	45.8	200.0	H	223.0	39.4	6.4	28.2	74

Remark: 1. Correction Factor = Antenna factor+ Insertion loss (cable loss + amplifier gain)

Frequency (MHz)	Average (dBuV/m)	Height (cm)	Polarization	Azimuth (deg)	Reading value (dBuV/m)	Correct Factor (dB)	Margin (dB)	Limit (dBuV/m)
3351.875000	28.1	200.0	V	252.0	30.4	-2.3	25.9	54
4076.875000	28.8	200.0	V	262.0	29.7	-0.9	25.2	54
4800.000000	30.9	200.0	H	25.0	29.6	1.3	23.1	54
5174.375000	32.1	200.0	H	0.0	30.0	2.1	21.9	54
5811.875000	38.7	200.0	H	83.0	34.3	4.4	15.3	54
6991.875000	36.1	200.0	V	213.0	29.6	6.5	17.9	54

Remark: 1. Correction Factor = Antenna factor+ Insertion loss (cable loss + amplifier gain)

802.11a CH157

FCC RE 1G-3GHz PK+AV Class B

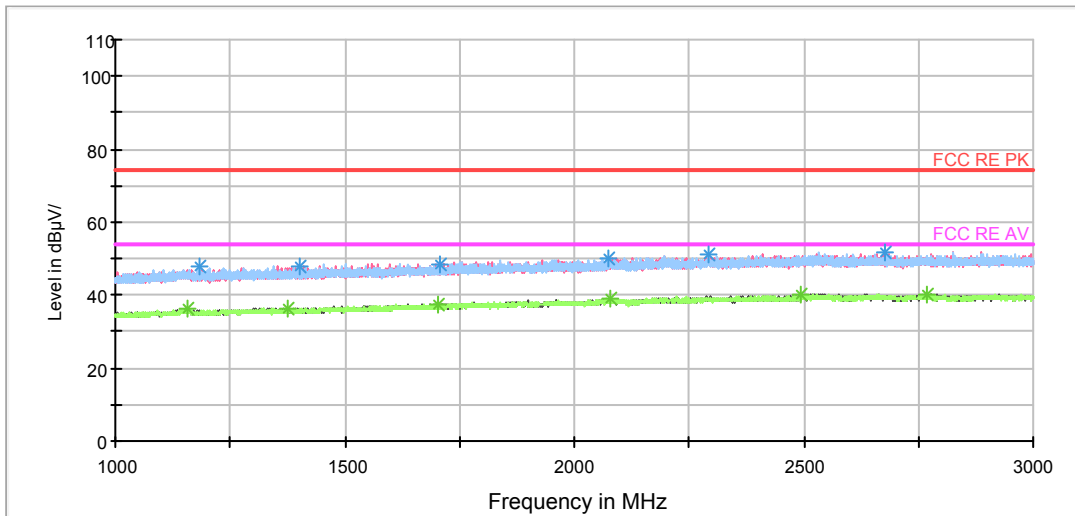

Radiates Emission from 1GHz to 3GHz

RE 3-18GHz PK+AV



Note: The signal beyond the limit is carrier.

Radiates Emission from 3GHz to 8GHz

RE 3-18GHz PK+AV

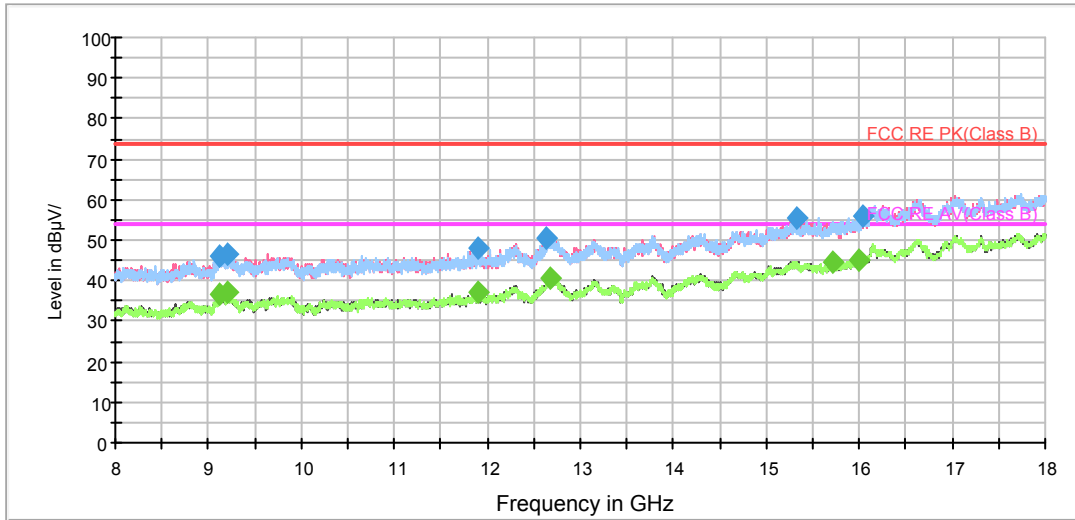

Radiates Emission from 8GHz to 18GHz

RE 18-26.5GHz PK+AV

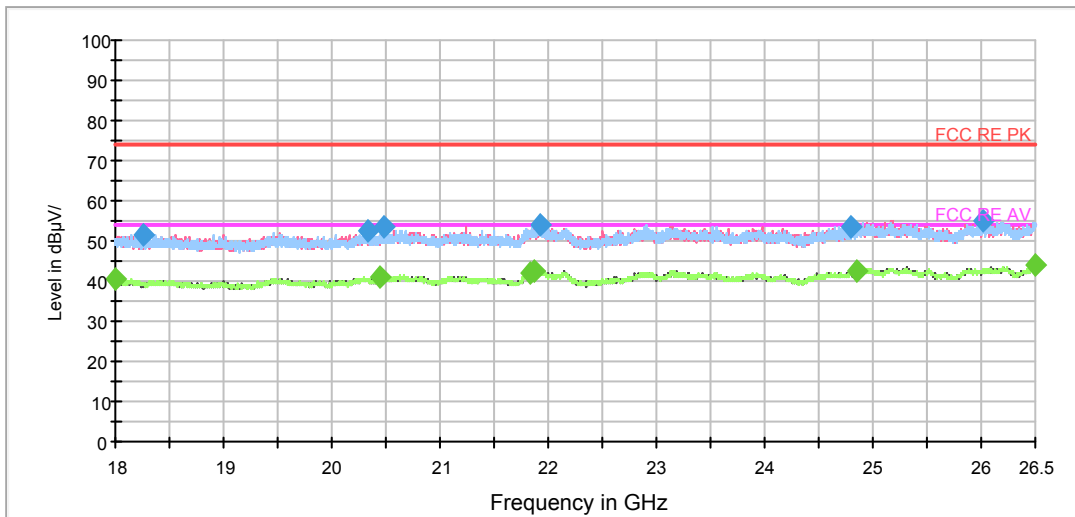

Radiates Emission from 18GHz to 26.5GHz

RE 26.5-40GHz PK+AV Class B

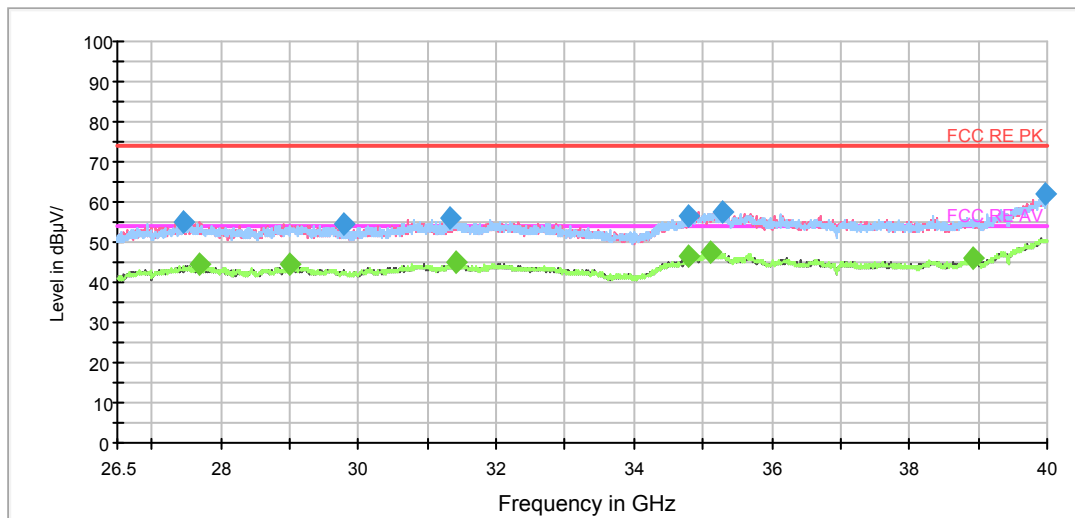

Radiates Emission from 26.5GHz to 40GHz

Frequency (MHz)	Peak (dBuV/m)	Height (cm)	Polarization	Azimuth (deg)	Reading value (dBuV/m)	Correct Factor (dB)	Margin (dB)	Limit (dBuV/m)
3480.625000	37.9	200.0	H	107.0	39.9	-2.0	36.1	74
4138.125000	39.2	200.0	V	310.0	39.5	-0.3	34.8	74
4865.625000	40.6	200.0	H	0.0	38.9	1.7	33.4	74
5526.875000	42.9	200.0	H	77.0	39.8	3.1	31.1	74
5768.750000	55.2	200.0	H	58.0	51.5	3.7	18.8	74
6896.875000	46.4	200.0	V	9.0	40.2	6.2	27.6	74

Remark: 1. Correction Factor = Antenna factor+ Insertion loss (cable loss + amplifier gain)

Frequency (MHz)	Average (dBuV/m)	Height (cm)	Polarization	Azimuth (deg)	Reading value (dBuV/m)	Correct Factor (dB)	Margin (dB)	Limit (dBuV/m)
3186.250000	28.2	200.0	H	77.0	31.1	-2.9	25.8	54
3897.500000	28.6	200.0	H	87.0	29.9	-1.3	25.4	54
4800.000000	31.3	200.0	H	0.0	30.0	1.3	22.7	54
5530.625000	32.9	200.0	H	125.0	29.7	3.2	21.1	54
5768.125000	41.9	200.0	H	87.0	38.2	3.7	12.1	54
6983.750000	36.0	200.0	H	214.0	29.6	6.4	18.0	54

Remark: 1. Correction Factor = Antenna factor+ Insertion loss (cable loss + amplifier gain)

802.11a CH165

FCC RE 1G-3GHz PK+AV Class B

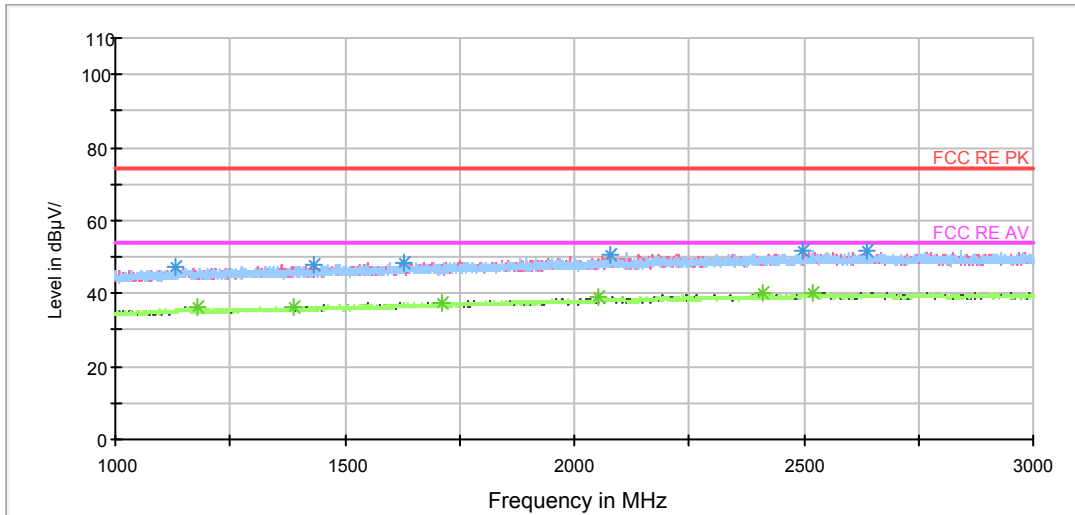

Radiates Emission from 1GHz to 3GHz

RE 3-18GHz PK+AV

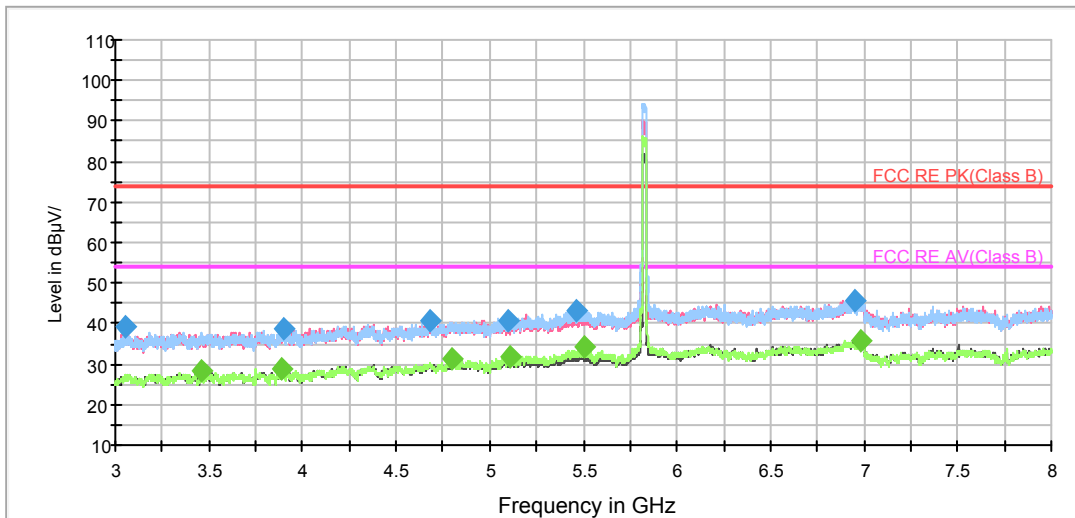

Note: The signal beyond the limit is carrier.

Radiates Emission from 3GHz to 8GHz

RE 3-18GHz PK+AV

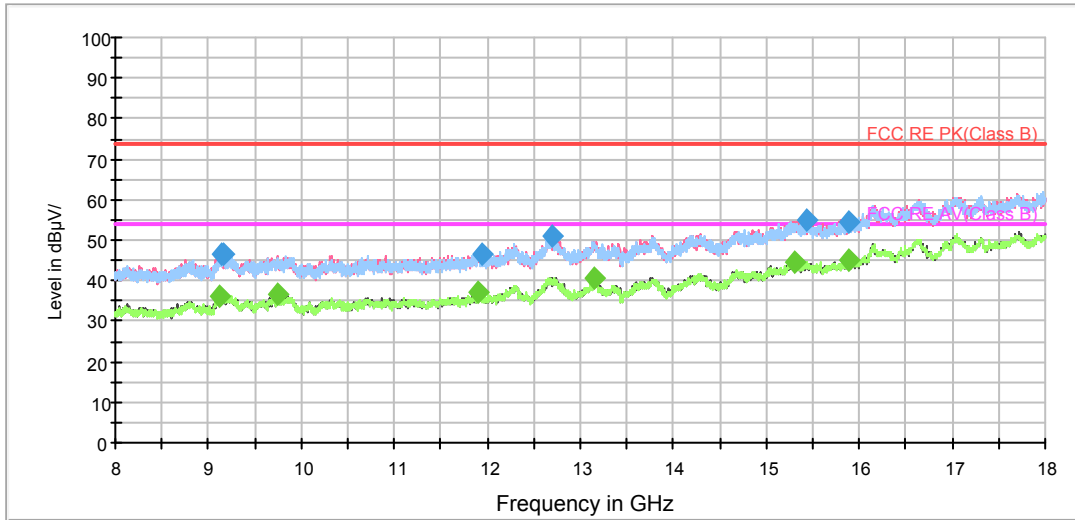

Radiates Emission from 8GHz to 18GHz

RE 18-26.5GHz PK+AV

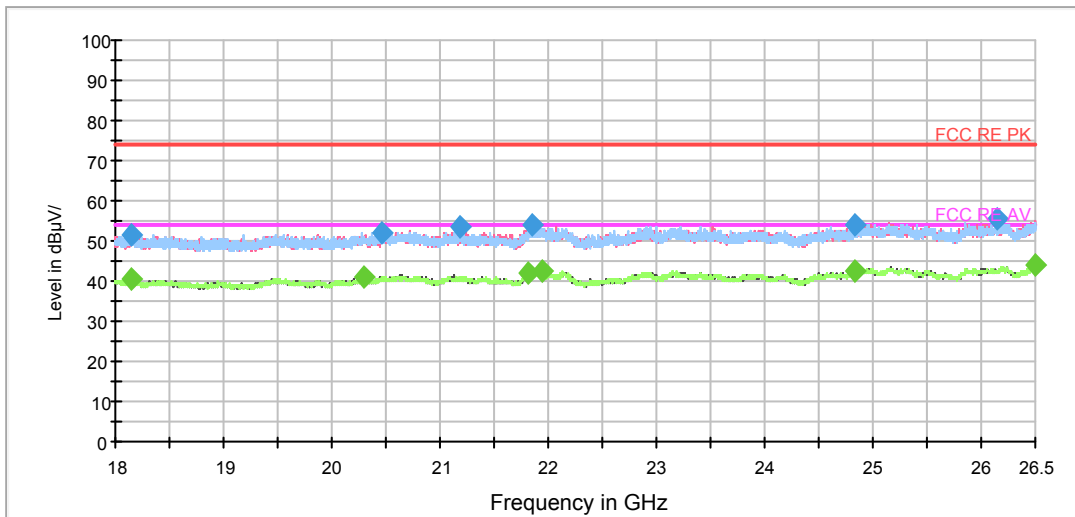

Radiates Emission from 18GHz to 26.5GHz

RE 26.5-40GHz PK+AV Class B

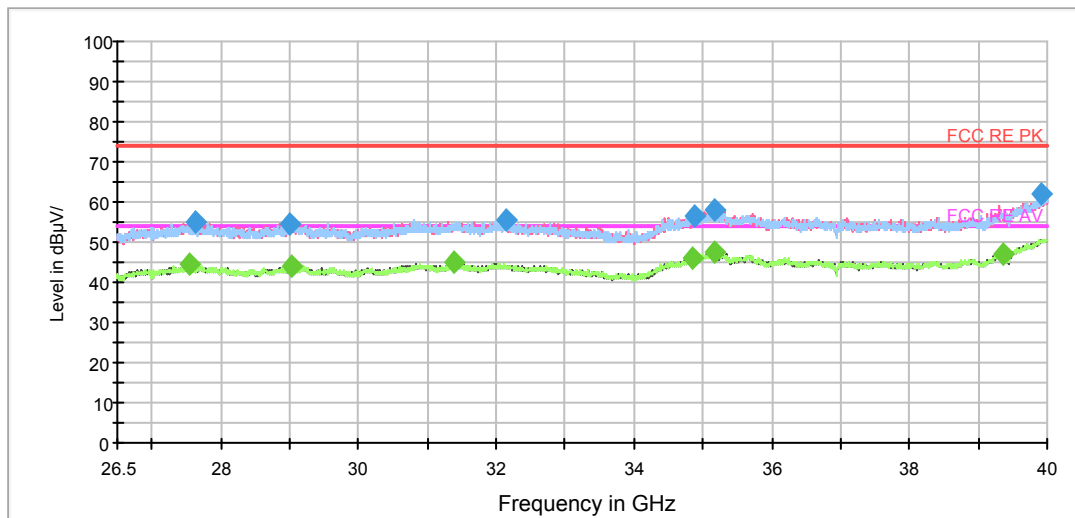

Radiates Emission from 26.5GHz to 40GHz

Frequency (MHz)	Peak (dBuV/m)	Height (cm)	Polarization	Azimuth (deg)	Reading value (dBuV/m)	Correct Factor (dB)	Margin (dB)	Limit (dBuV/m)
3051.250000	39.0	200.0	V	137.0	42.2	-3.2	35.0	74
3895.000000	38.9	200.0	V	266.0	40.2	-1.3	35.1	74
4677.500000	40.6	200.0	V	314.0	39.8	0.8	33.4	74
5098.750000	40.8	200.0	V	295.0	39.0	1.8	33.2	74
5462.500000	43.2	200.0	H	36.0	40.4	2.8	30.8	74
6955.625000	45.6	200.0	V	256.0	39.4	6.2	28.4	74

Remark: 1. Correction Factor = Antenna factor+ Insertion loss (cable loss + amplifier gain)

Frequency (MHz)	Average (dBuV/m)	Height (cm)	Polarization	Azimuth (deg)	Reading value (dBuV/m)	Correct Factor (dB)	Margin (dB)	Limit (dBuV/m)
3463.125000	28.3	200.0	V	285.0	30.5	-2.2	25.7	54
3885.000000	28.9	200.0	H	46.0	30.2	-1.3	25.1	54
4800.000000	31.1	200.0	H	8.0	29.8	1.3	22.9	54
5114.375000	31.6	200.0	H	0.0	29.8	1.8	22.4	54
5504.375000	34.0	200.0	H	36.0	30.9	3.1	20.0	54
6983.125000	35.6	200.0	H	283.0	29.2	6.4	18.4	54

Remark: 1. Correction Factor = Antenna factor+ Insertion loss (cable loss + amplifier gain)

802.11n (HT20) CH36

FCC RE 1G-3GHz PK+AV Class B

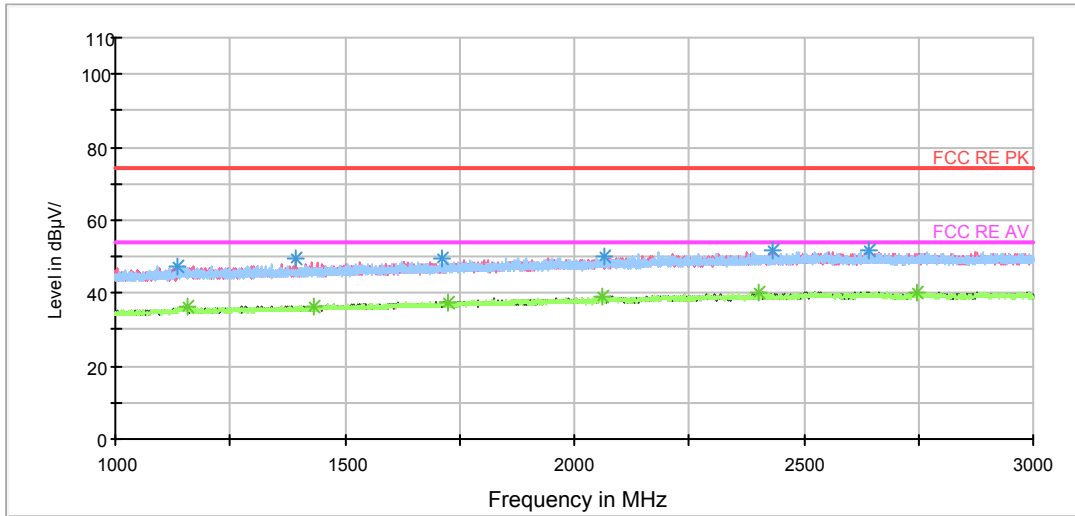

Radiates Emission from 1GHz to 3GHz

RE 3-18GHz AV

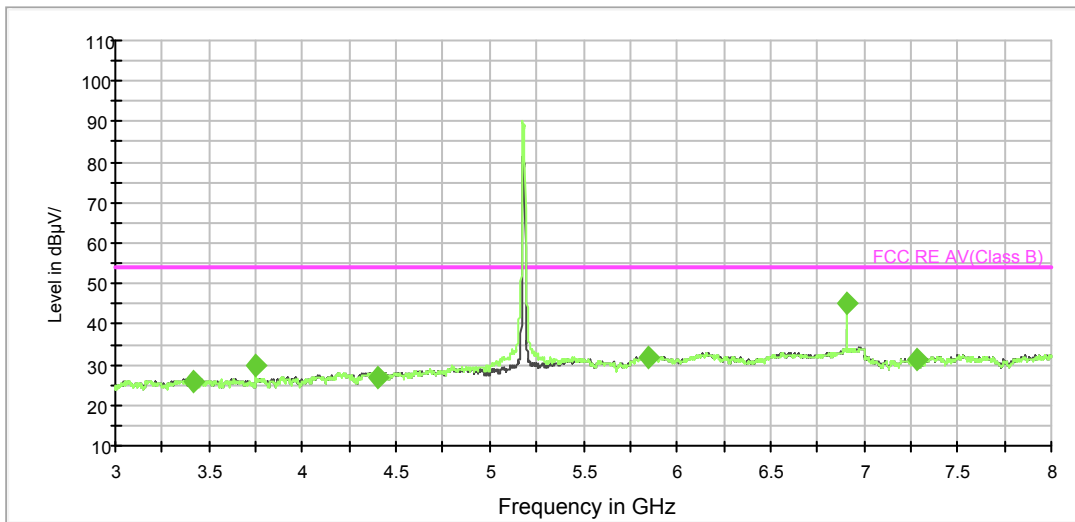

RE 3-18GHz PK+AV

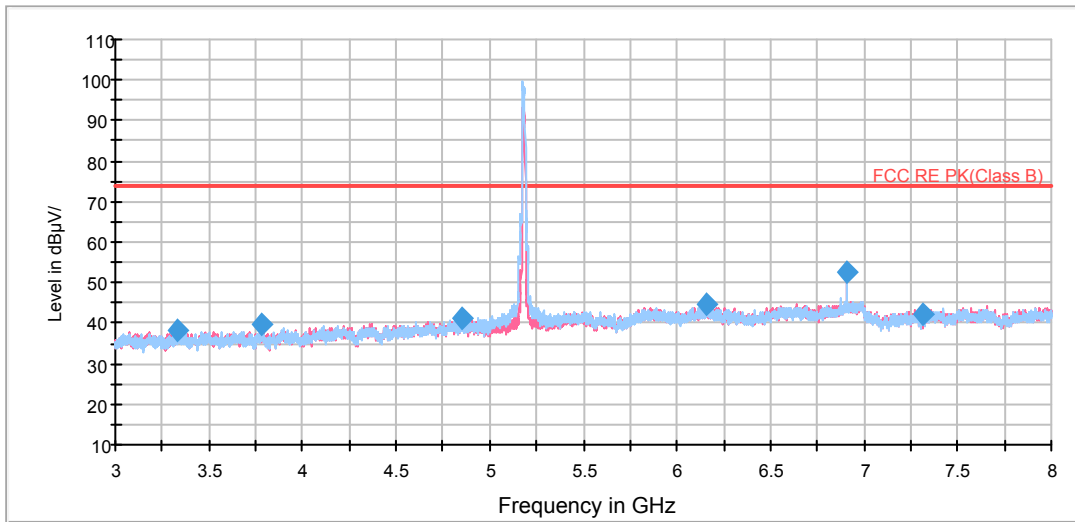

Note: The signal beyond the limit is carrier.
Radiates Emission from 3GHz to 8GHz

RE 3-18GHz PK+AV

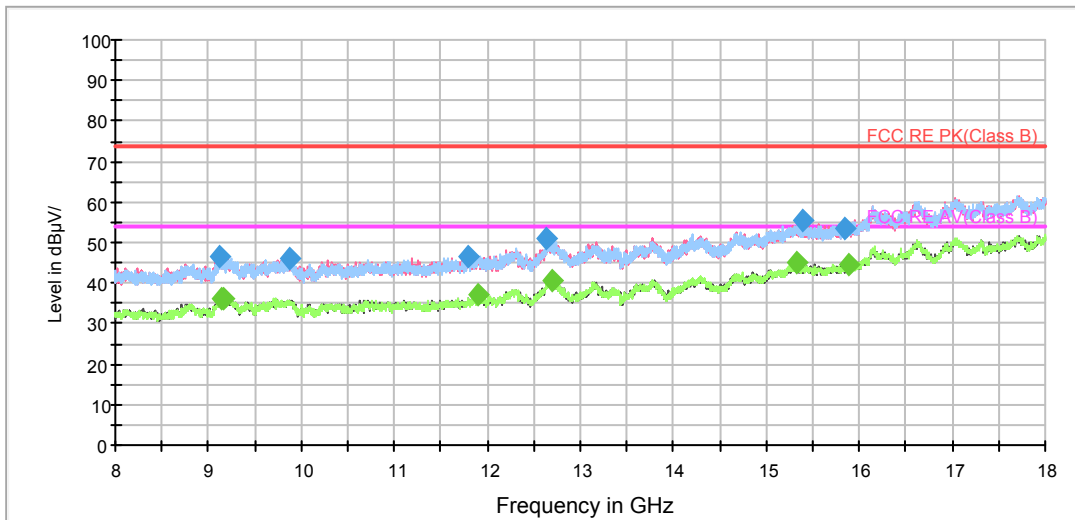

Radiates Emission from 8GHz to 18GHz

RE 18-26.5GHz PK+AV

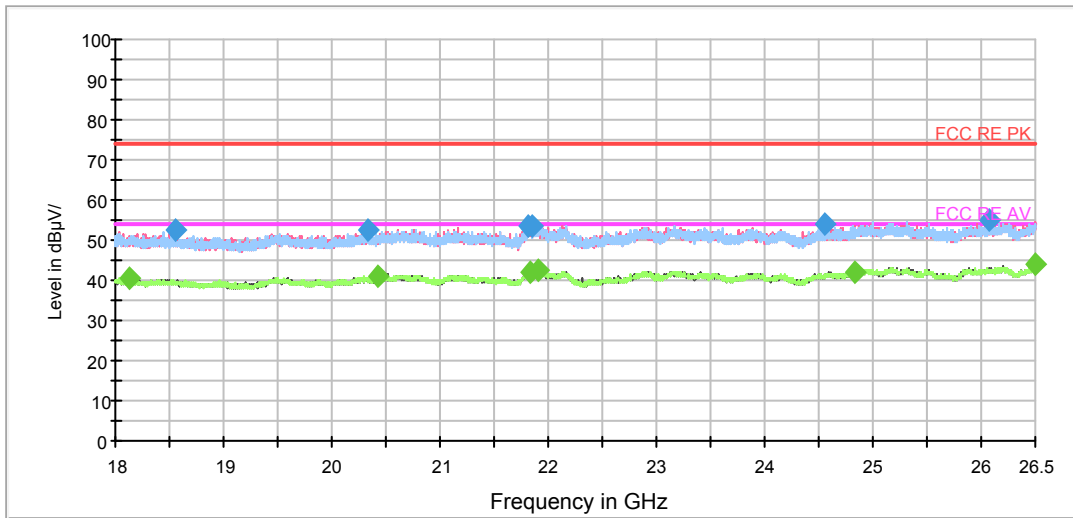

Radiates Emission from 18GHz to 26.5GHz

RE 26.5-40GHz PK+AV Class B

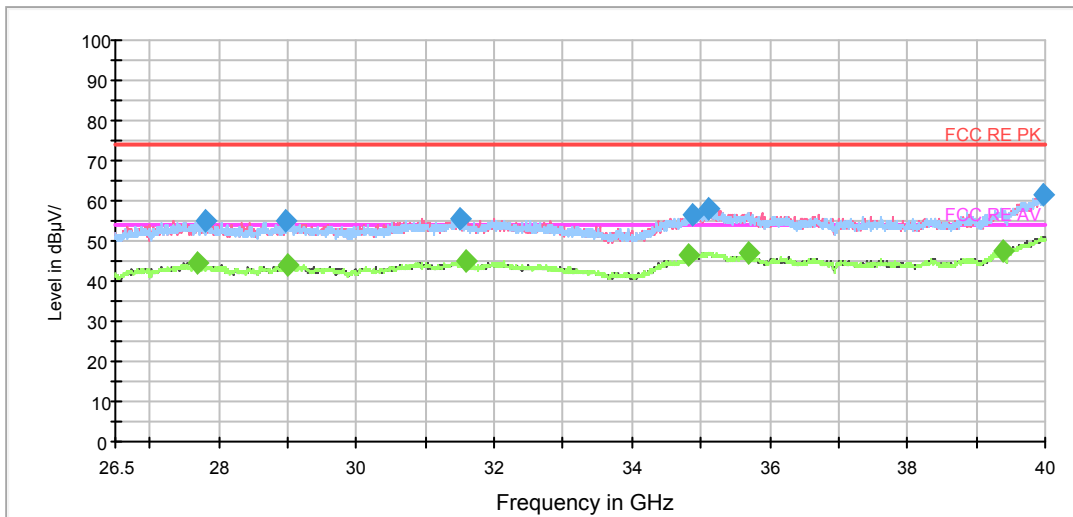

Radiates Emission from 26.5GHz to 40GHz

Frequency (MHz)	Peak (dBuV/m)	Height (cm)	Polarization	Azimuth (deg)	Reading value (dBuV/m)	Correct Factor (dB)	Margin (dB)	Limit (dBuV/m)
3326.875000	38.0	200.0	V	0.0	40.2	-2.2	36.0	74
3785.625000	39.8	200.0	H	161.0	41.6	-1.8	34.2	74
4848.125000	41.1	200.0	V	0.0	39.5	1.6	32.9	74
6160.000000	44.7	200.0	H	41.0	39.0	5.7	29.3	74
6906.875000	52.8	200.0	H	327.0	46.5	6.3	21.2	74
7314.375000	42.0	200.0	V	180.0	35.0	7.0	32.0	74

Remark: 1. Correction Factor = Antenna factor+ Insertion loss (cable loss + amplifier gain)



Frequency (MHz)	Average (dBuV/m)	Height (cm)	Polarization	Azimuth (deg)	Reading value (dBuV/m)	Correct Factor (dB)	Margin (dB)	Limit (dBuV/m)
3418.750000	25.7	200.0	V	0.0	28.3	-2.6	28.3	54
3751.250000	29.6	200.0	H	28.0	31.3	-1.7	24.4	54
4400.625000	26.8	200.0	V	333.0	26.7	0.1	27.2	54
5851.250000	31.9	200.0	V	0.0	27.2	4.7	22.1	54
6906.875000	45.2	200.0	H	280.0	38.9	6.3	8.8	54
7278.125000	31.4	200.0	V	0.0	24.4	7.0	22.6	54

Remark: 1. Correction Factor = Antenna factor+ Insertion loss (cable loss + amplifier gain)

802.11n (HT20) CH40

FCC RE 1G-3GHz PK+AV Class B

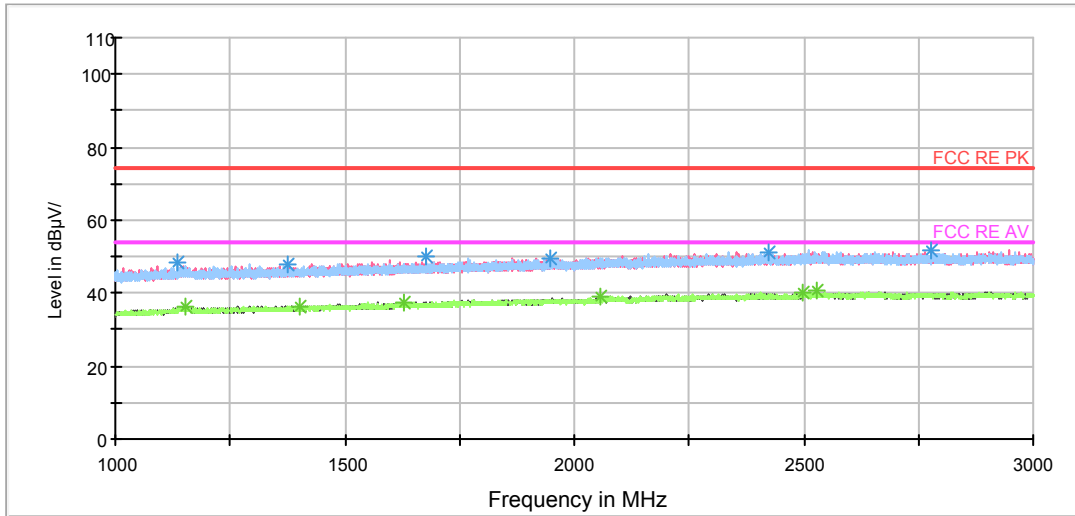

Radiates Emission from 1GHz to 3GHz

RE 3-18GHz PK+AV

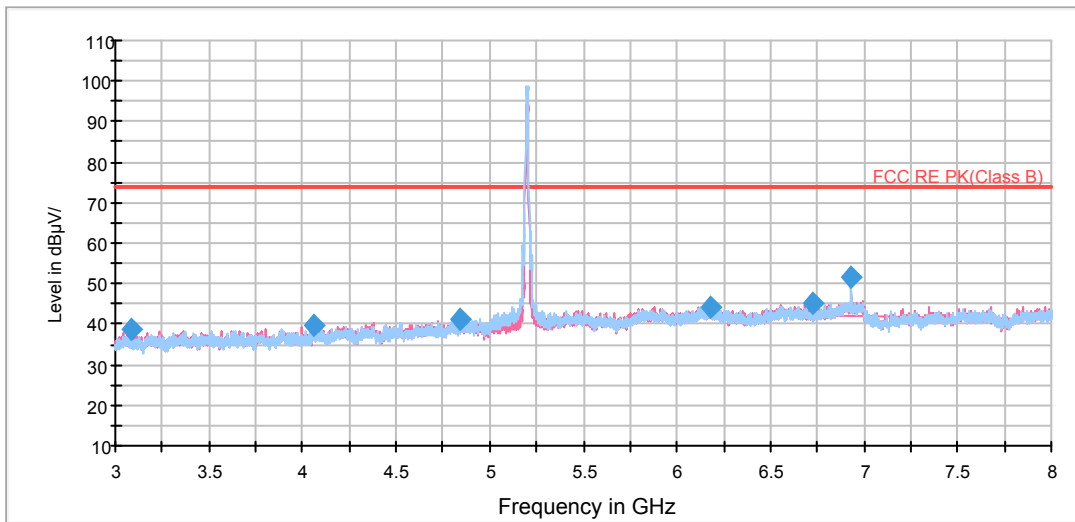

RE 3-18GHz AV

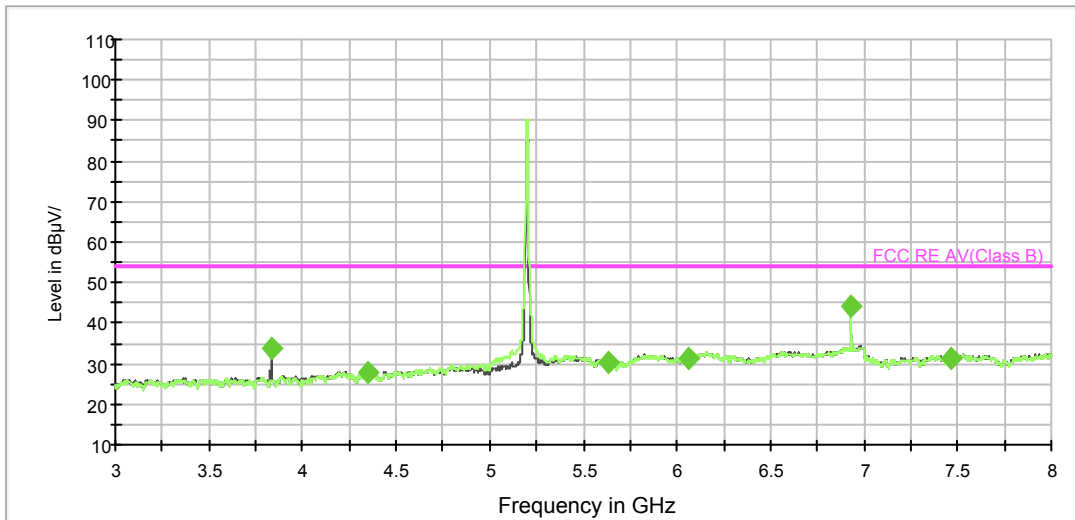

Note: The signal beyond the limit is carrier.
Radiates Emission from 3GHz to 8GHz

RE 3-18GHz PK+AV

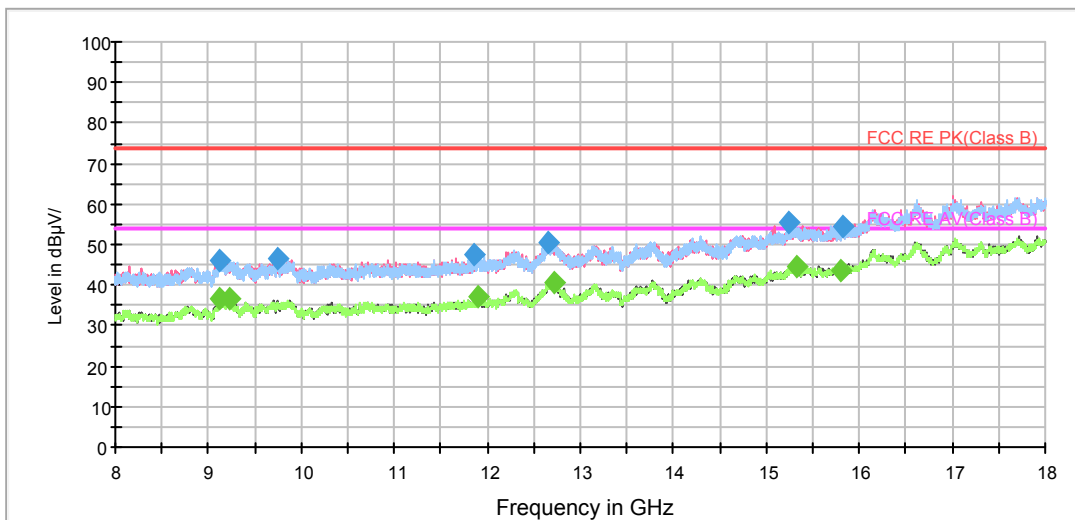

Radiates Emission from 8GHz to 18GHz

RE 18-26.5GHz PK+AV

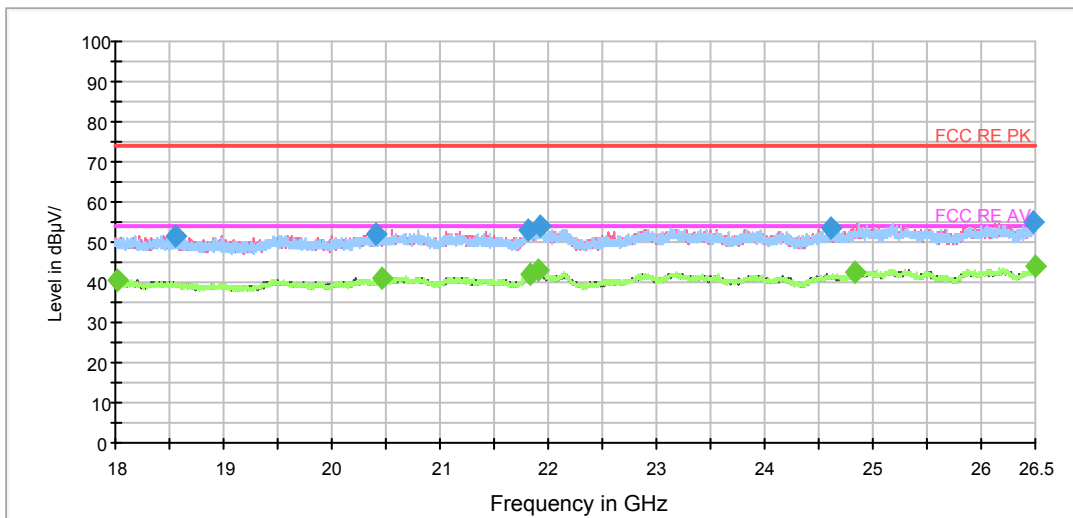

Radiates Emission from 18GHz to 26.5GHz

RE 26.5-40GHz PK+AV Class B

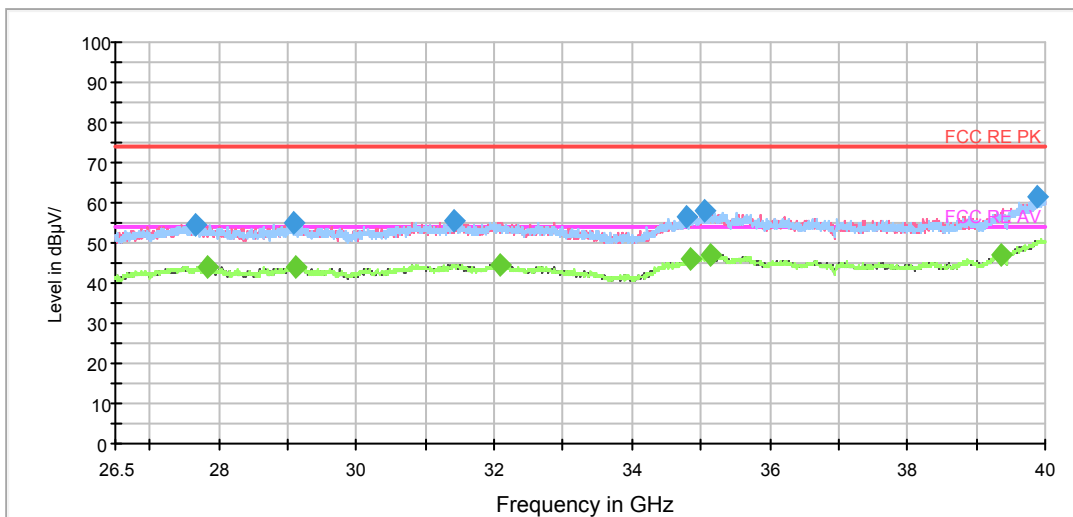

Radiates Emission from 26.5GHz to 40GHz

Frequency (MHz)	Peak (dBuV/m)	Height (cm)	Polarization	Azimuth (deg)	Reading value (dBuV/m)	Correct Factor (dB)	Margin (dB)	Limit (dBuV/m)
3081.250000	38.6	200.0	H	113.0	41.6	-3.0	35.4	74
4061.250000	39.7	200.0	V	161.0	40.8	-1.1	34.3	74
4845.625000	41.4	200.0	H	0.0	39.8	1.6	32.6	74
6178.750000	44.0	200.0	V	181.0	38.6	5.4	30.0	74
6722.500000	45.0	200.0	H	0.0	39.7	5.3	29.0	74
6933.750000	51.6	200.0	V	355.0	45.4	6.2	22.4	74

Remark: 1. Correction Factor = Antenna factor+ Insertion loss (cable loss + amplifier gain)



Frequency (MHz)	Average (dBuV/m)	Height (cm)	Polarization	Azimuth (deg)	Reading value (dBuV/m)	Correct Factor (dB)	Margin (dB)	Limit (dBuV/m)
3831.875000	33.7	200.0	V	0.0	35.4	-1.7	20.3	54
4348.750000	27.7	200.0	V	0.0	27.2	0.5	26.3	54
5628.750000	30.5	200.0	V	0.0	27.1	3.4	23.5	54
6061.875000	31.4	200.0	V	0.0	26.5	4.9	22.6	54
6933.750000	44.1	200.0	V	0.0	37.9	6.2	9.9	54
7460.000000	31.4	200.0	V	248.0	24.5	6.9	22.6	54

Remark: 1. Correction Factor = Antenna factor+ Insertion loss (cable loss + amplifier gain)

802.11n (HT20) CH48

FCC RE 1G-3GHz PK+AV Class B

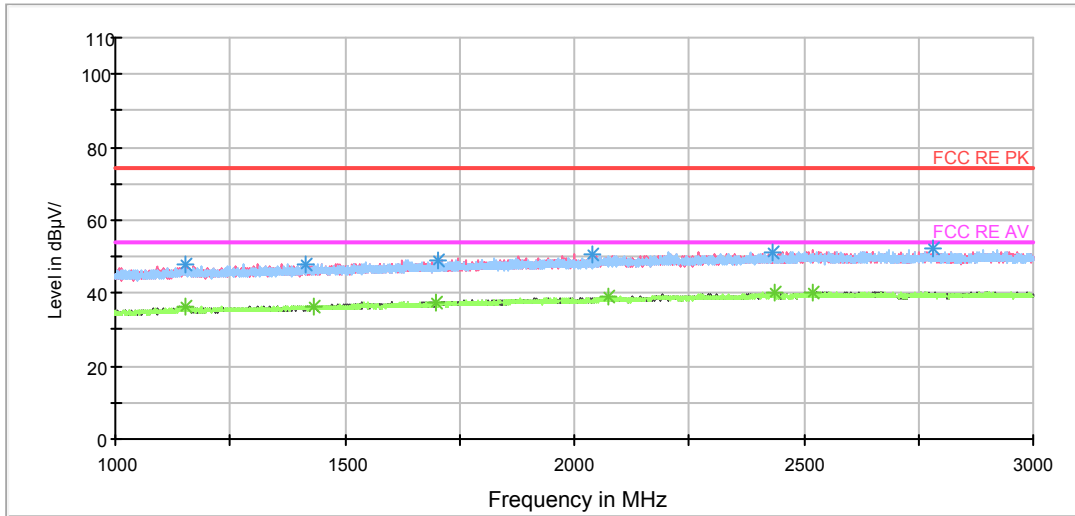

Radiates Emission from 1GHz to 3GHz

RE 3-18GHz AV

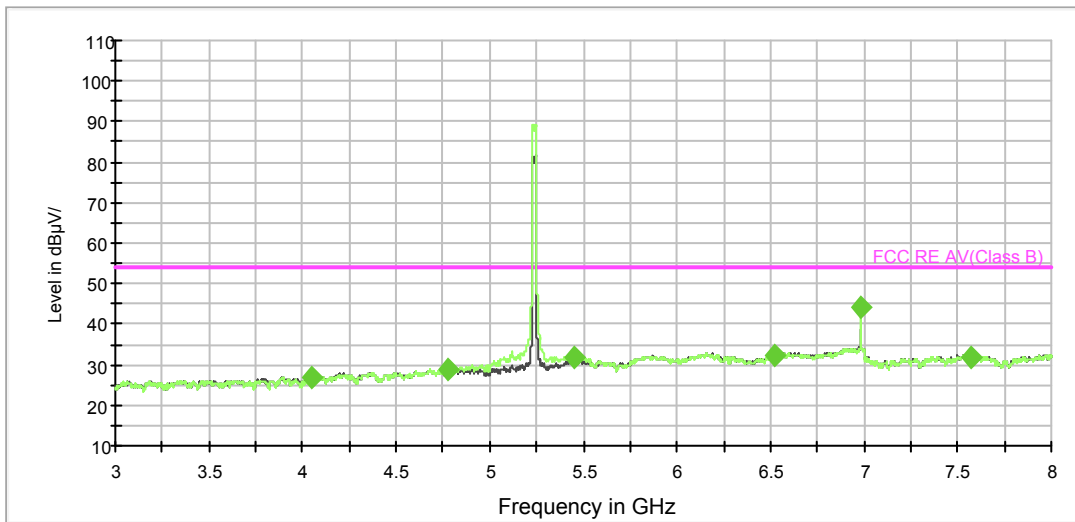

RE 3-18GHz PK+AV

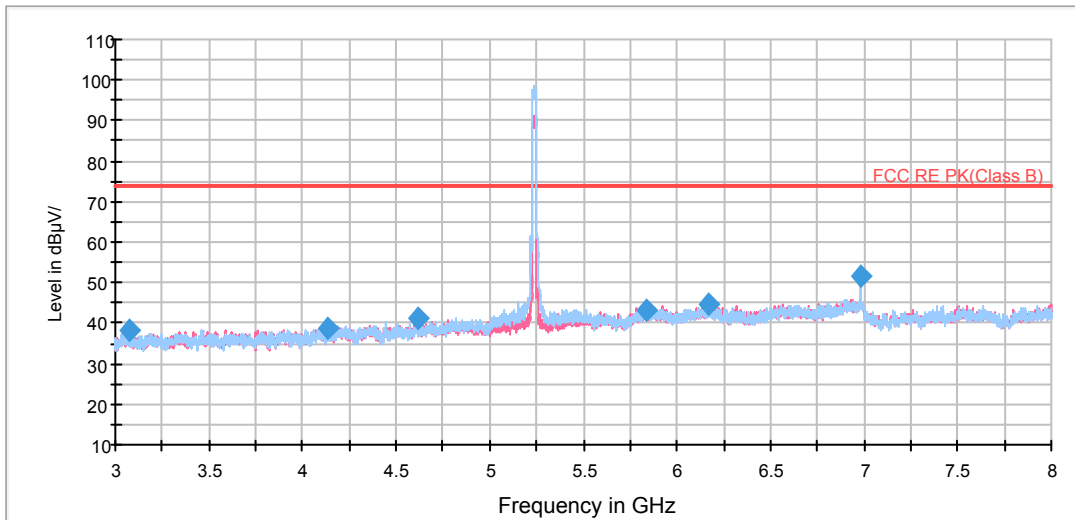

Note: The signal beyond the limit is carrier.
Radiates Emission from 3GHz to 8GHz

RE 3-18GHz PK+AV

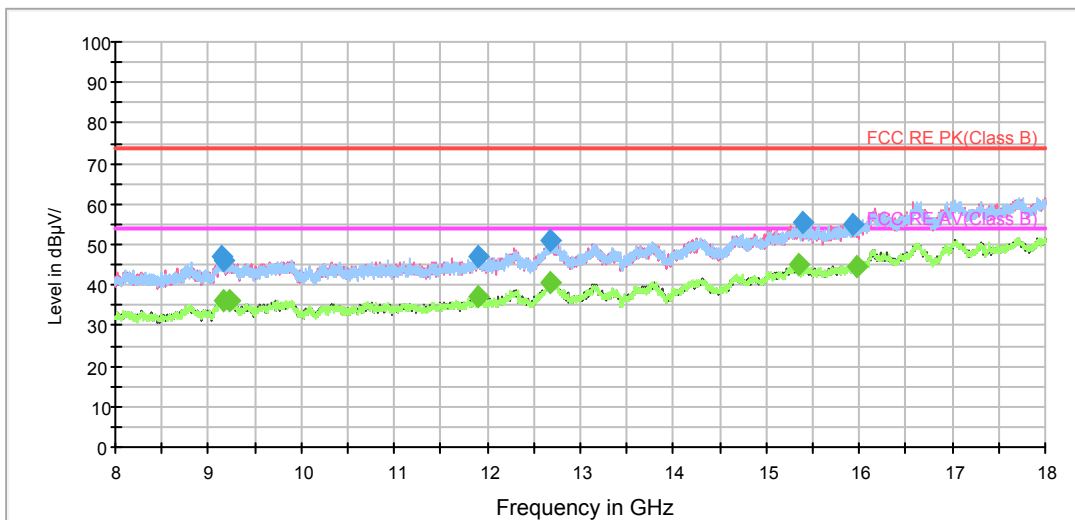

Radiates Emission from 8GHz to 18GHz

RE 18-26.5GHz PK+AV

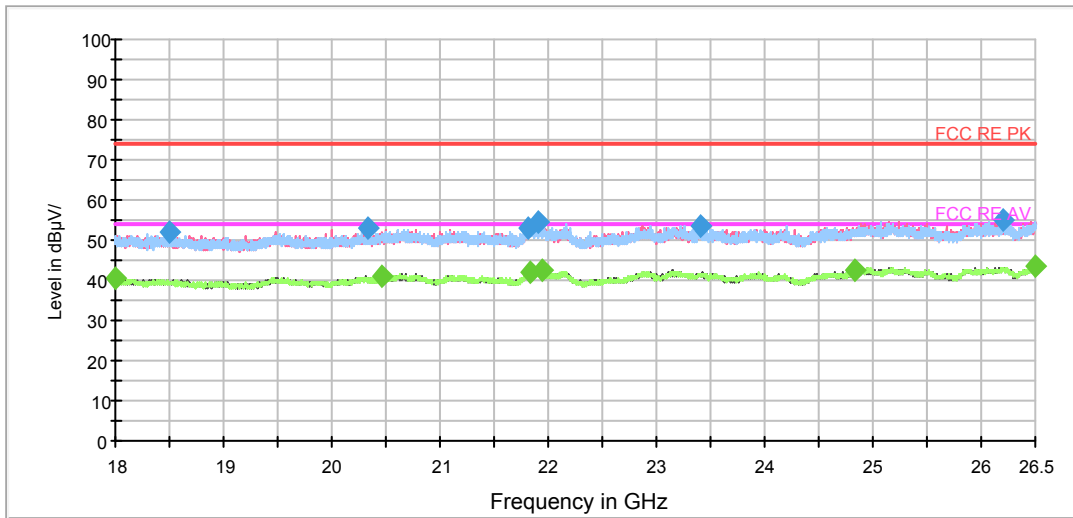

Radiates Emission from 18GHz to 26.5GHz

RE 26.5-40GHz PK+AV Class B

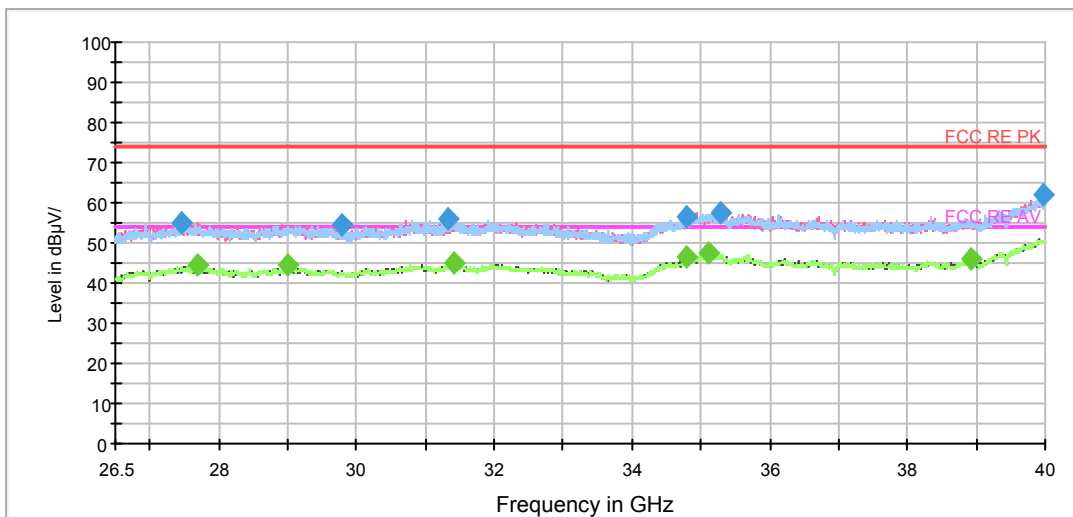

Radiates Emission from 26.5GHz to 40GHz

Frequency (MHz)	Peak (dBuV/m)	Height (cm)	Polarization	Azimuth (deg)	Reading value (dBuV/m)	Correct Factor (dB)	Margin (dB)	Limit (dBuV/m)
3070.000000	38.1	200.0	V	45.0	41.1	-3.0	35.9	74
4136.875000	38.6	200.0	V	352.0	38.9	-0.3	35.4	74
4618.125000	41.1	200.0	H	25.0	40.2	0.9	32.9	74
5837.500000	43.3	200.0	H	84.0	38.8	4.5	30.7	74
6167.500000	44.6	200.0	V	205.0	39.0	5.6	29.4	74
6986.875000	51.5	200.0	H	337.0	45.1	6.4	22.5	74

Remark: 1. Correction Factor = Antenna factor+ Insertion loss (cable loss + amplifier gain)



Frequency (MHz)	Average (dBuV/m)	Height (cm)	Polarization	Azimuth (deg)	Reading value (dBuV/m)	Correct Factor (dB)	Margin (dB)	Limit (dBuV/m)
4053.125000	26.6	200.0	V	0.0	27.7	-1.1	27.4	54
4775.000000	28.7	200.0	H	0.0	27.6	1.1	25.3	54
5453.750000	31.9	200.0	H	0.0	29.1	2.8	22.1	54
6523.750000	32.1	200.0	V	0.0	26.6	5.5	21.9	54
6986.875000	44.0	200.0	H	196.0	37.6	6.4	10.0	54
7576.250000	31.8	200.0	V	0.0	24.7	7.1	22.2	54

Remark: 1. Correction Factor = Antenna factor+ Insertion loss (cable loss + amplifier gain)

802.11n (HT20) CH52

FCC RE 1G-3GHz PK+AV Class B

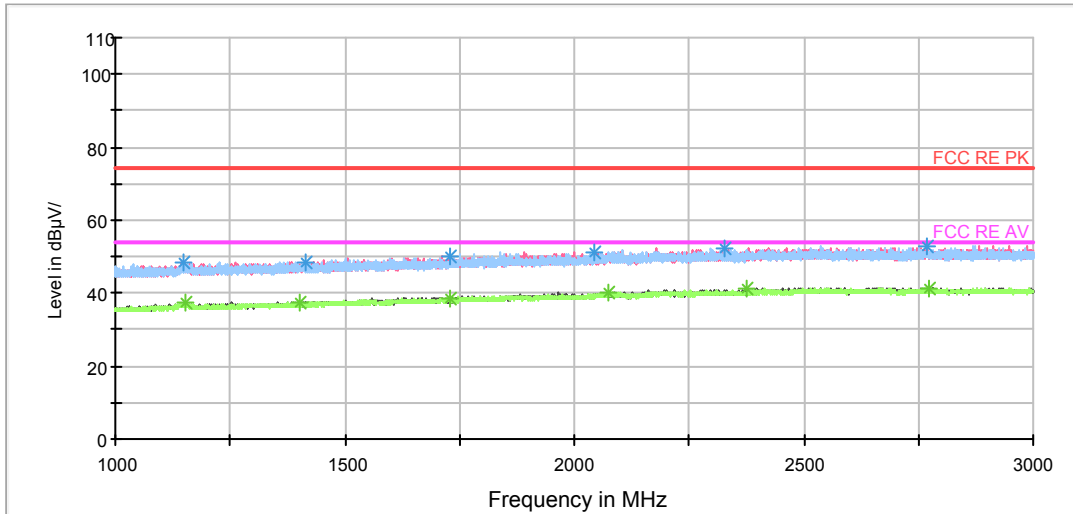

Radiates Emission from 1GHz to 3GHz

RE 3-18GHz PK+AV

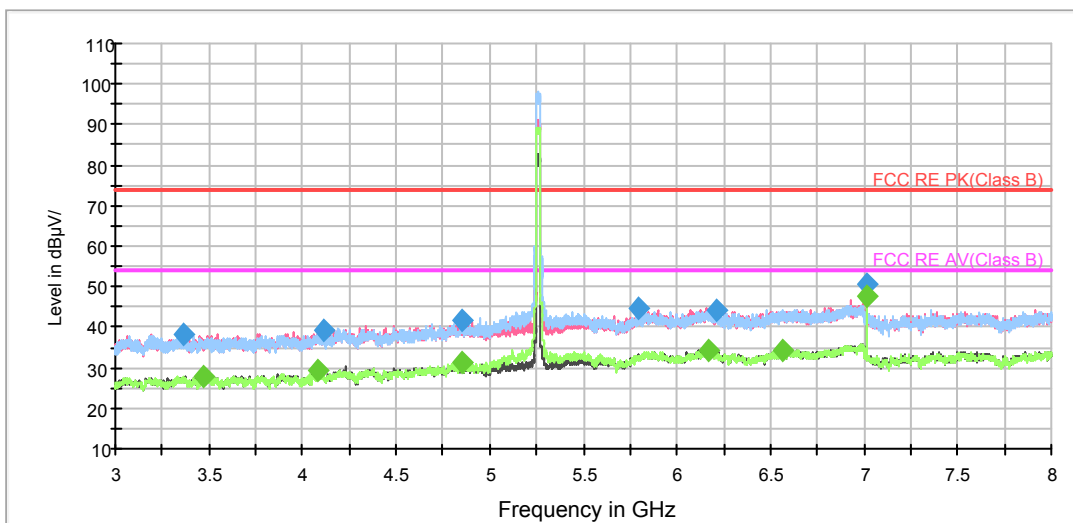

Note: The signal beyond the limit is carrier.

Radiates Emission from 3GHz to 8GHz

RE 3-18GHz PK+AV

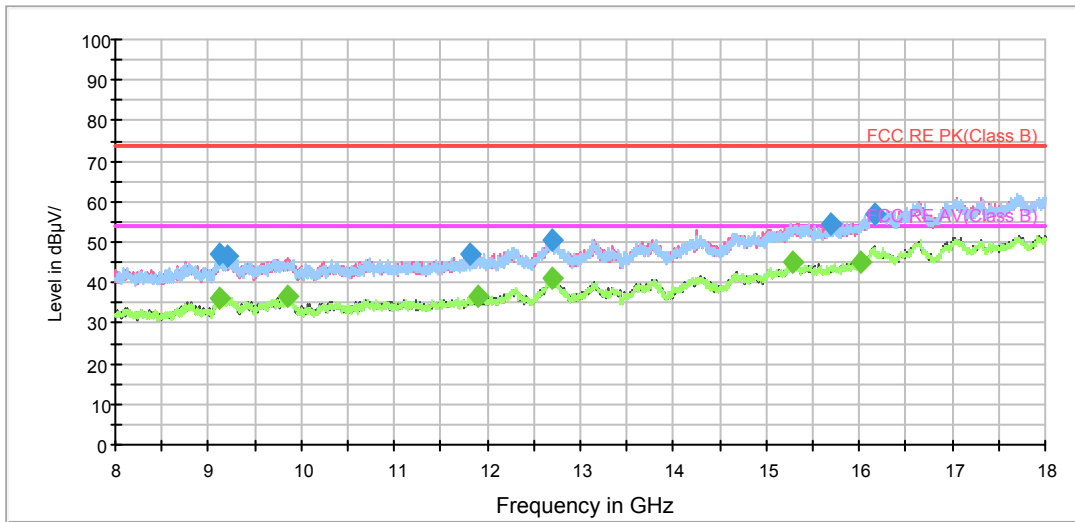

Radiates Emission from 8GHz to 18GHz

RE 18-26.5GHz PK+AV

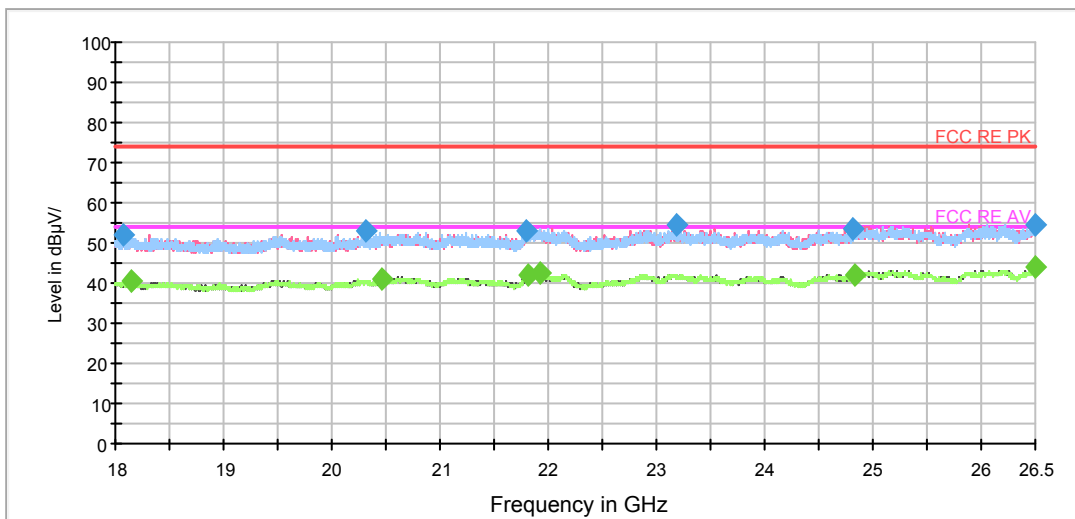

Radiates Emission from 18GHz to 26.5GHz

RE 26.5-40GHz PK+AV Class B

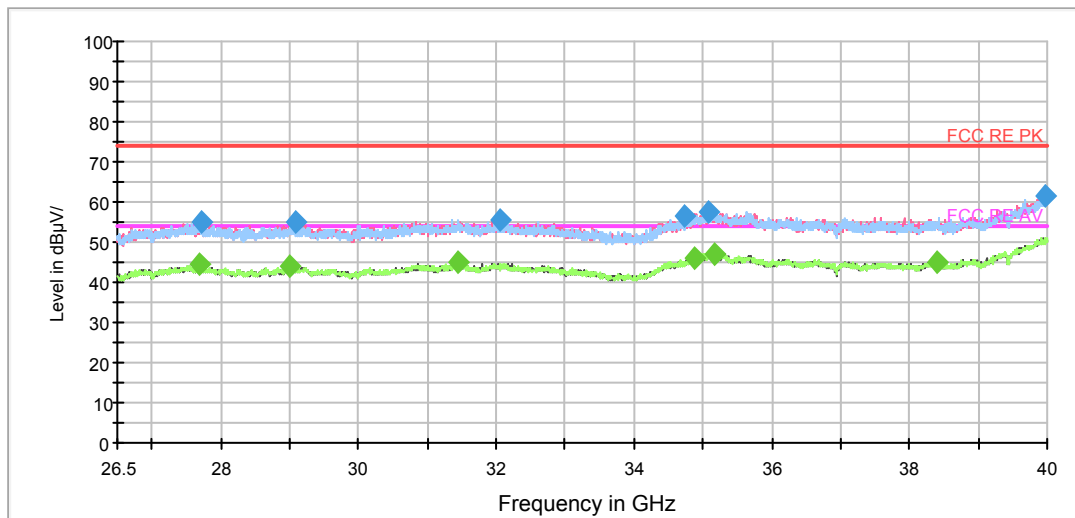

Radiates Emission from 26.5GHz to 40GHz

Frequency (MHz)	Peak (dBuV/m)	Height (cm)	Polarization	Azimuth (deg)	Reading value (dBuV/m)	Correct Factor (dB)	Margin (dB)	Limit (dBuV/m)
3361.250000	38.2	200.0	H	0.0	40.5	-2.3	35.8	74
4116.250000	39.0	200.0	V	304.0	39.6	-0.6	35.0	74
4851.875000	41.5	200.0	V	87.0	39.9	1.6	32.5	74
5791.875000	44.6	200.0	V	265.0	40.5	4.1	29.4	74
6216.250000	43.9	200.0	H	123.0	38.5	5.4	30.1	74
7013.750000	50.4	200.0	H	273.0	43.9	6.5	23.6	74

Remark: 1. Correction Factor = Antenna factor+ Insertion loss (cable loss + amplifier gain)

Frequency (MHz)	Average (dBuV/m)	Height (cm)	Polarization	Azimuth (deg)	Reading value (dBuV/m)	Correct Factor (dB)	Margin (dB)	Limit (dBuV/m)
3467.500000	28.0	200.0	V	304.0	30.1	-2.1	26.0	54
4079.375000	29.2	200.0	H	114.0	30.1	-0.9	24.8	54
4848.125000	31.1	200.0	H	16.0	29.5	1.6	22.9	54
6170.000000	34.2	200.0	V	353.0	28.7	5.5	19.8	54
6566.875000	34.5	200.0	V	98.0	28.8	5.7	19.5	54
7013.750000	47.5	200.0	H	273.0	41.0	6.5	6.5	54

Remark: 1. Correction Factor = Antenna factor+ Insertion loss (cable loss + amplifier gain)

802.11n (HT20) CH60

FCC RE 1G-3GHz PK+AV Class B

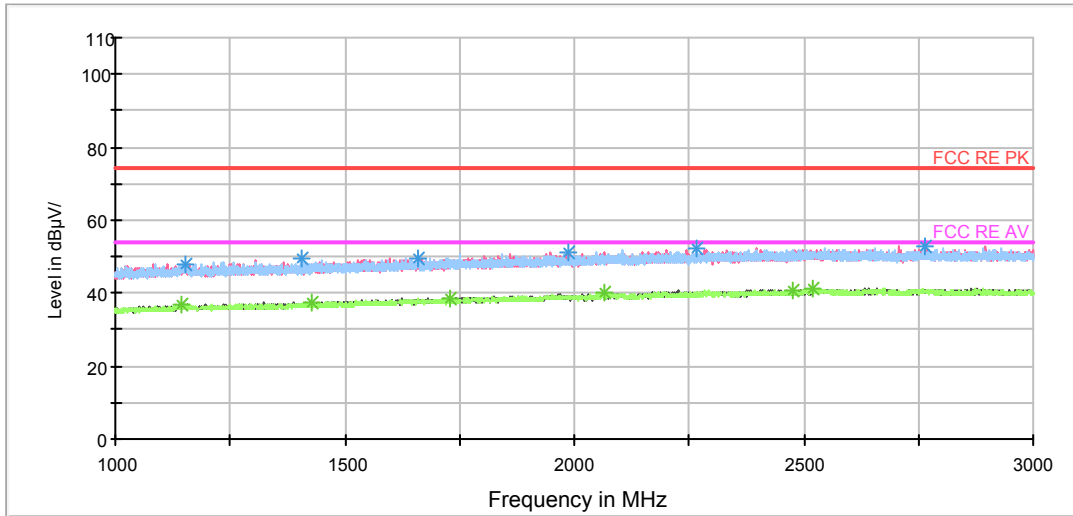

Radiates Emission from 1GHz to 3GHz

RE 3-18GHz PK+AV

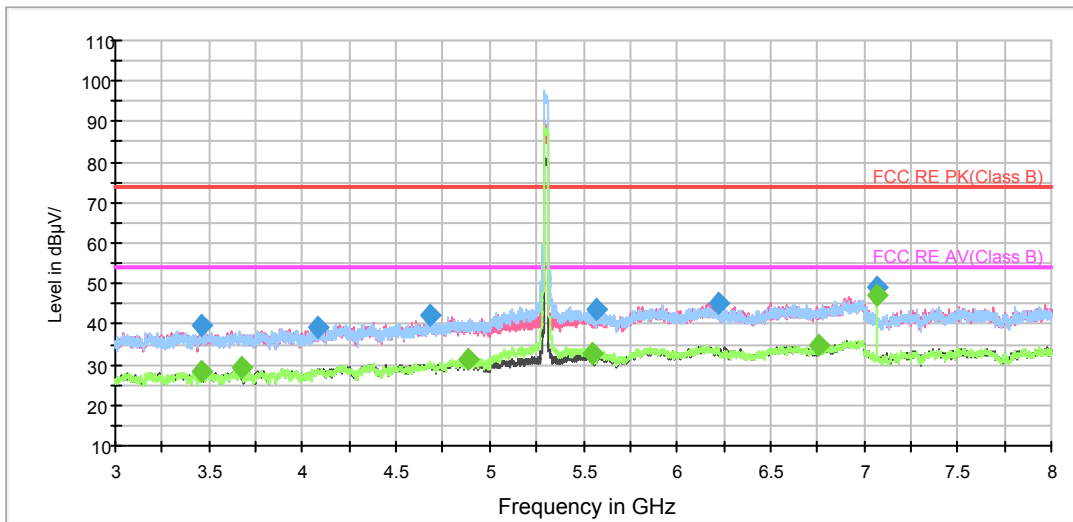

Note: The signal beyond the limit is carrier.

Radiates Emission from 3GHz to 8GHz

RE 3-18GHz PK+AV

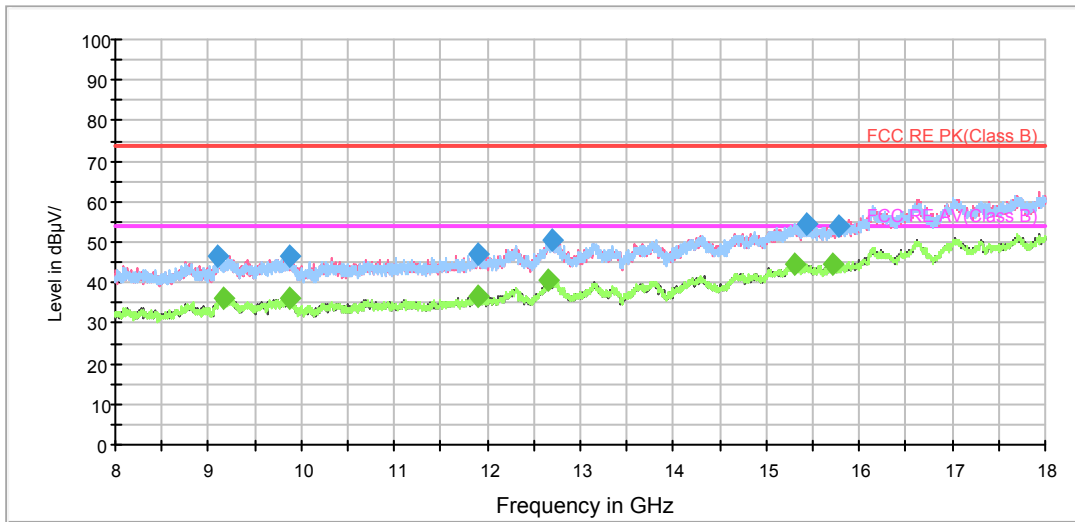

Radiates Emission from 8GHz to 18GHz

RE 18-26.5GHz PK+AV

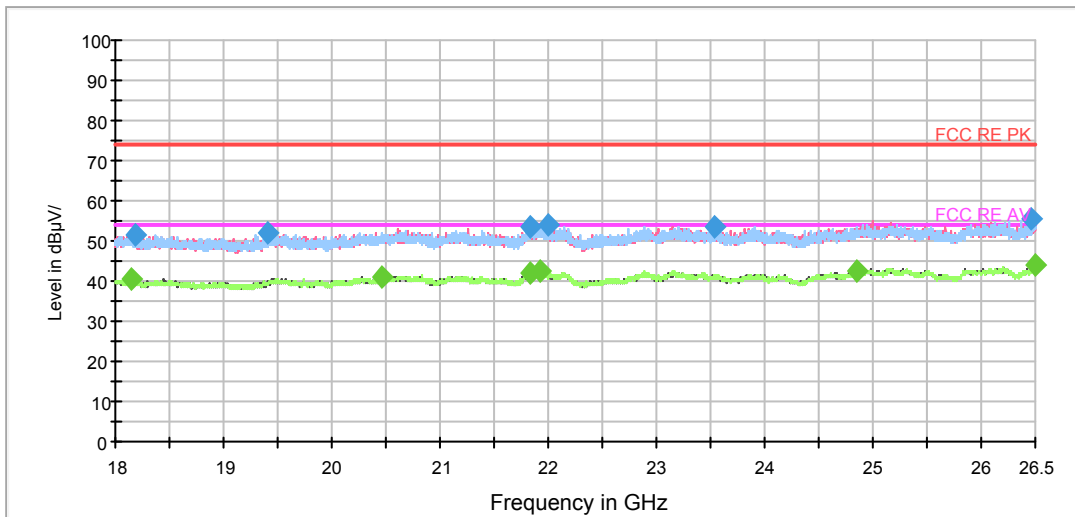

Radiates Emission from 18GHz to 26.5GHz

RE 26.5-40GHz PK+AV Class B

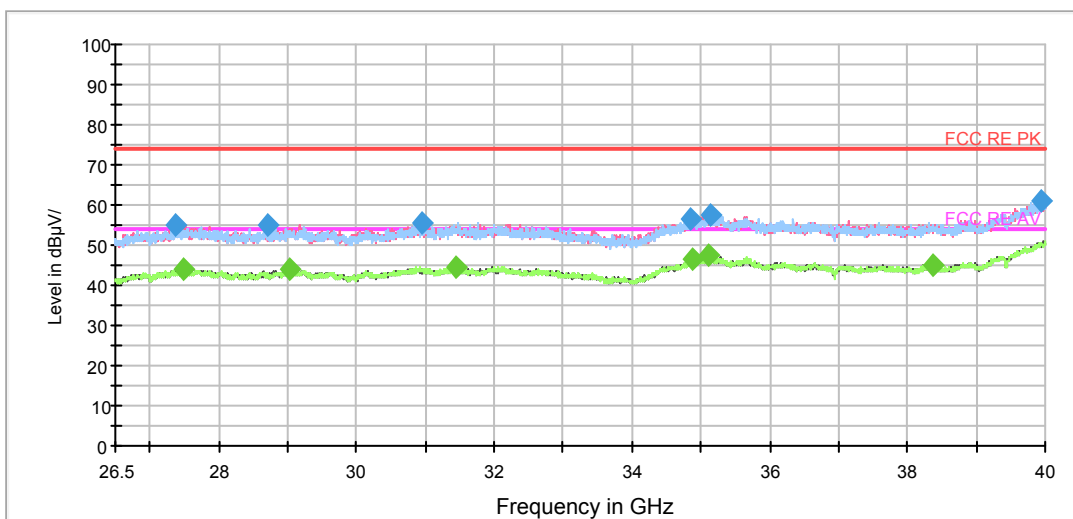

Radiates Emission from 26.5GHz to 40GHz

Frequency (MHz)	Peak (dBuV/m)	Height (cm)	Polarization	Azimuth (deg)	Reading value (dBuV/m)	Correct Factor (dB)	Margin (dB)	Limit (dBuV/m)
3465.000000	39.6	200.0	H	45.0	41.7	-2.1	34.4	74
4081.250000	39.3	200.0	V	304.0	40.2	-0.9	34.7	74
4684.375000	42.3	200.0	V	265.0	41.5	0.8	31.7	74
5573.750000	43.7	200.0	V	255.0	40.3	3.4	30.3	74
6218.750000	45.3	200.0	V	255.0	39.9	5.4	28.7	74
7066.875000	49.3	200.0	H	84.0	43.1	6.2	24.7	74

Remark: 1. Correction Factor = Antenna factor+ Insertion loss (cable loss + amplifier gain)

Frequency (MHz)	Average (dBuV/m)	Height (cm)	Polarization	Azimuth (deg)	Reading value (dBuV/m)	Correct Factor (dB)	Margin (dB)	Limit (dBuV/m)
3460.625000	28.4	200.0	H	25.0	30.6	-2.2	25.6	54
3671.875000	29.3	200.0	H	0.0	31.1	-1.8	24.7	54
4879.375000	31.1	200.0	V	275.0	29.3	1.8	22.9	54
5551.875000	32.8	200.0	H	35.0	29.6	3.2	21.2	54
6757.500000	34.7	200.0	V	108.0	29.2	5.5	19.3	54
7066.875000	46.9	200.0	H	84.0	40.7	6.2	7.1	54

Remark: 1. Correction Factor = Antenna factor+ Insertion loss (cable loss + amplifier gain)

802.11n (HT20) CH64

FCC RE 1G-3GHz PK+AV Class B

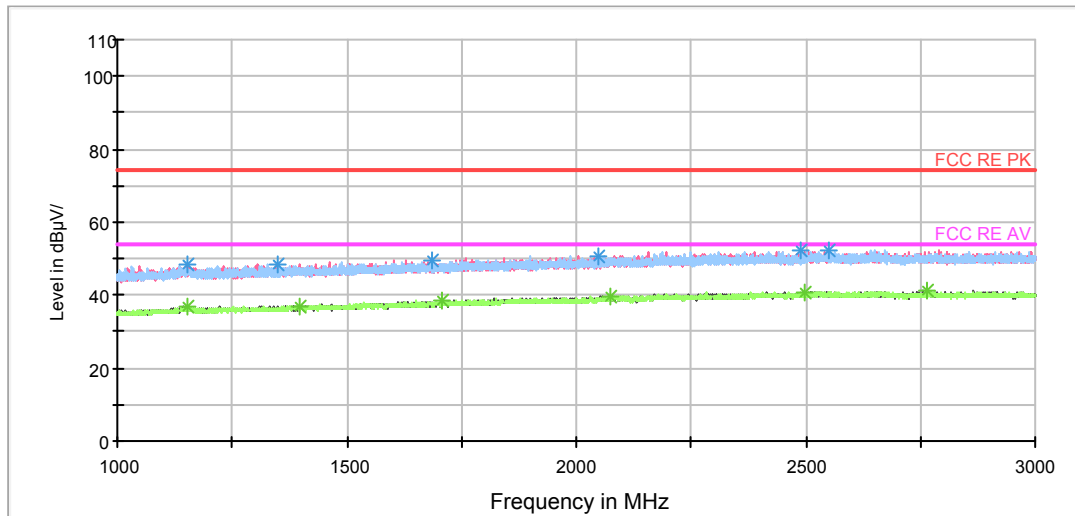

Radiates Emission from 1GHz to 3GHz

RE 3-18GHz PK+AV

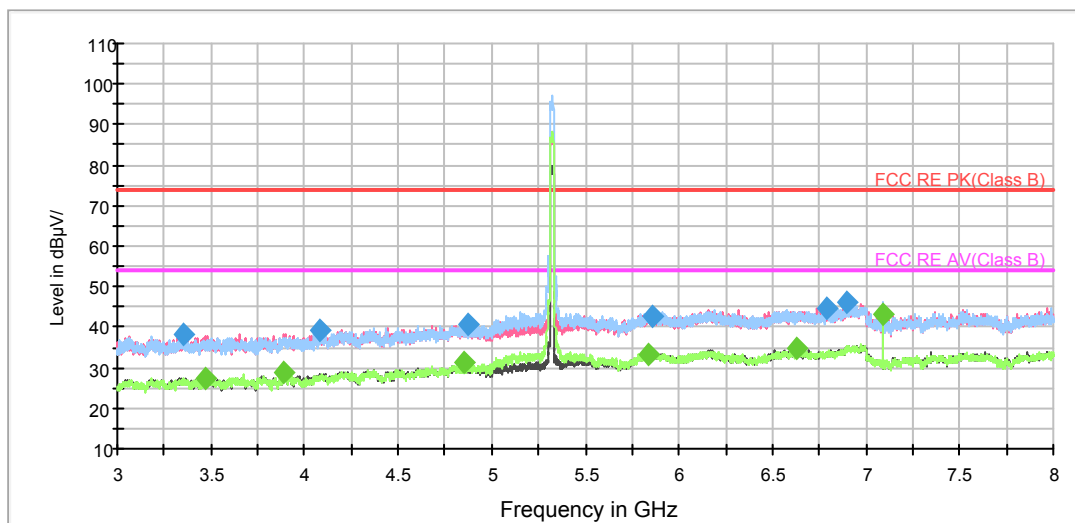

Note: The signal beyond the limit is carrier.

Radiates Emission from 3GHz to 8GHz

RE 3-18GHz PK+AV

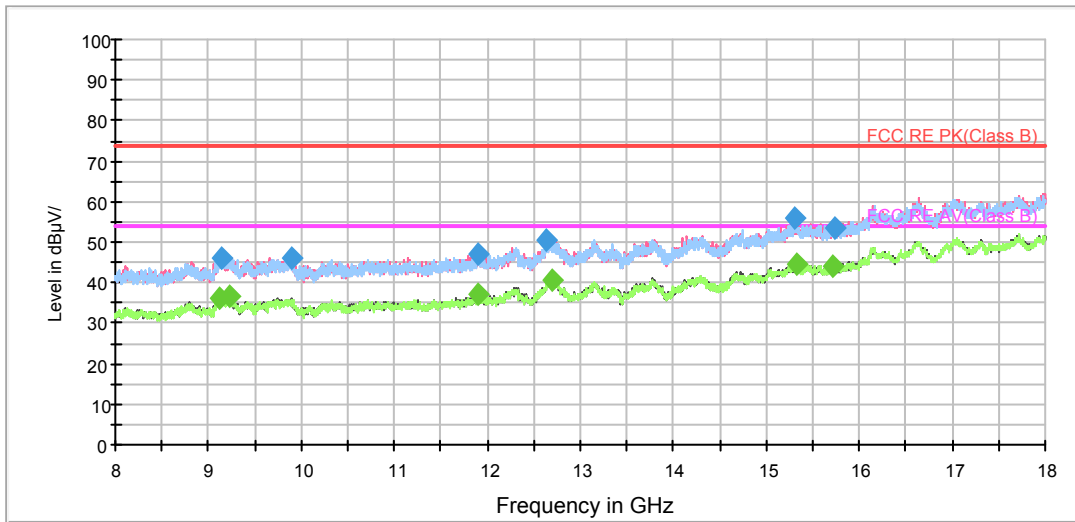

Radiates Emission from 8GHz to 18GHz

RE 18-26.5GHz PK+AV

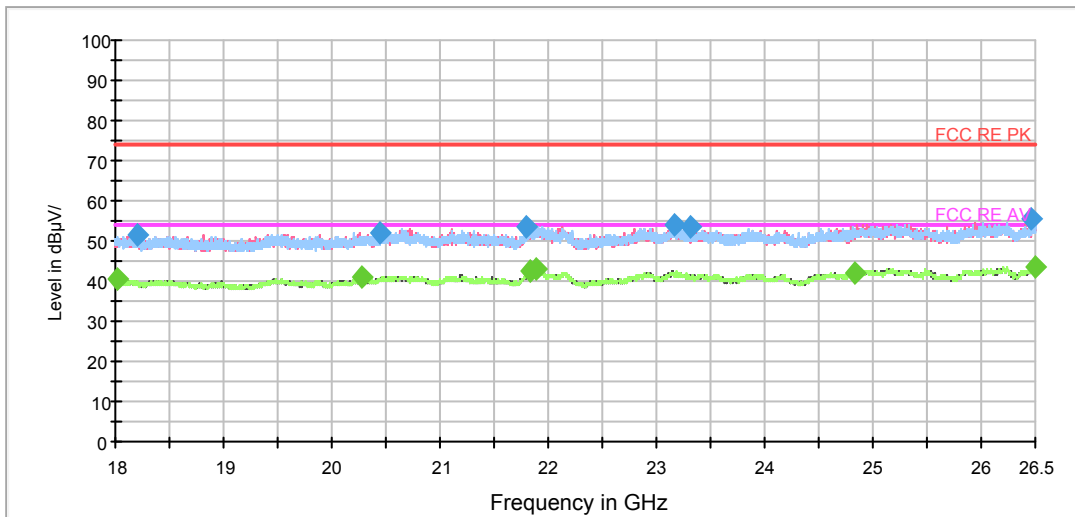

Radiates Emission from 18GHz to 26.5GHz

RE 26.5-40GHz PK+AV Class B

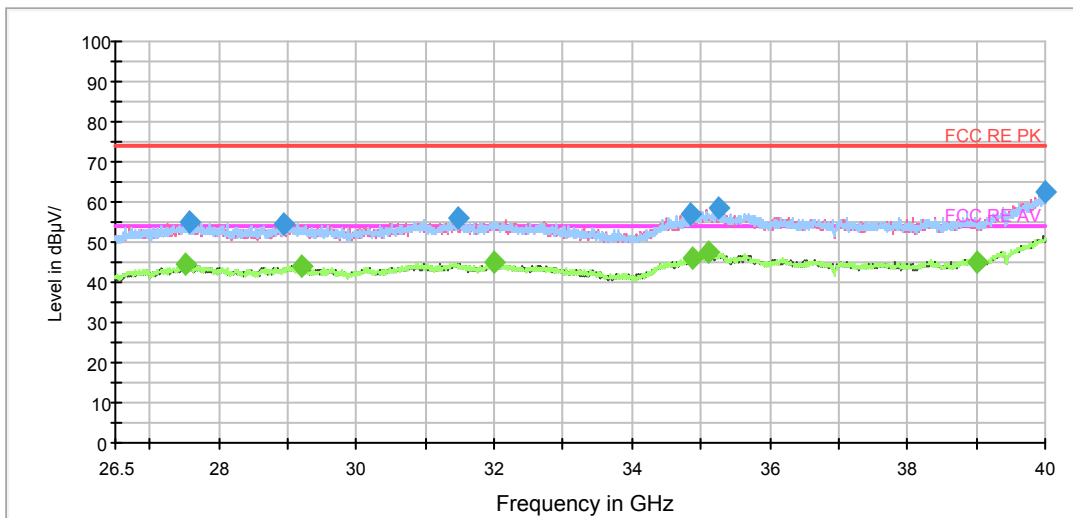

Radiates Emission from 26.5GHz to 40GHz

Frequency (MHz)	Peak (dBuV/m)	Height (cm)	Polarization	Azimuth (deg)	Reading value (dBuV/m)	Correct Factor (dB)	Margin (dB)	Limit (dBuV/m)
3354.375000	38.3	200.0	H	46.0	40.6	-2.3	35.7	74
4079.375000	39.3	200.0	V	112.0	40.2	-0.9	34.7	74
4875.000000	40.7	200.0	H	223.0	38.9	1.8	33.3	74
5860.000000	42.9	200.0	H	85.0	38.1	4.8	31.1	74
6787.500000	44.7	200.0	V	250.0	39.0	5.7	29.3	74
6901.250000	46.2	200.0	H	114.0	39.9	6.3	27.8	74

Remark: 1. Correction Factor = Antenna factor+ Insertion loss (cable loss + amplifier gain)

Frequency (MHz)	Average (dBuV/m)	Height (cm)	Polarization	Azimuth (deg)	Reading value (dBuV/m)	Correct Factor (dB)	Margin (dB)	Limit (dBuV/m)
3470.625000	27.2	200.0	V	142.0	29.3	-2.1	26.8	54
3892.500000	28.7	200.0	H	56.0	30.0	-1.3	25.3	54
4851.875000	31.2	200.0	H	0.0	29.6	1.6	22.8	54
5833.750000	33.2	200.0	V	220.0	28.7	4.5	20.8	54
6628.125000	34.6	200.0	V	211.0	29.1	5.5	19.4	54
7093.750000	43.1	200.0	H	254.0	37.0	6.1	10.9	54

Remark: 1. Correction Factor = Antenna factor+ Insertion loss (cable loss + amplifier gain)

802.11n (HT20) CH100

FCC RE 1G-3GHz PK+AV Class B

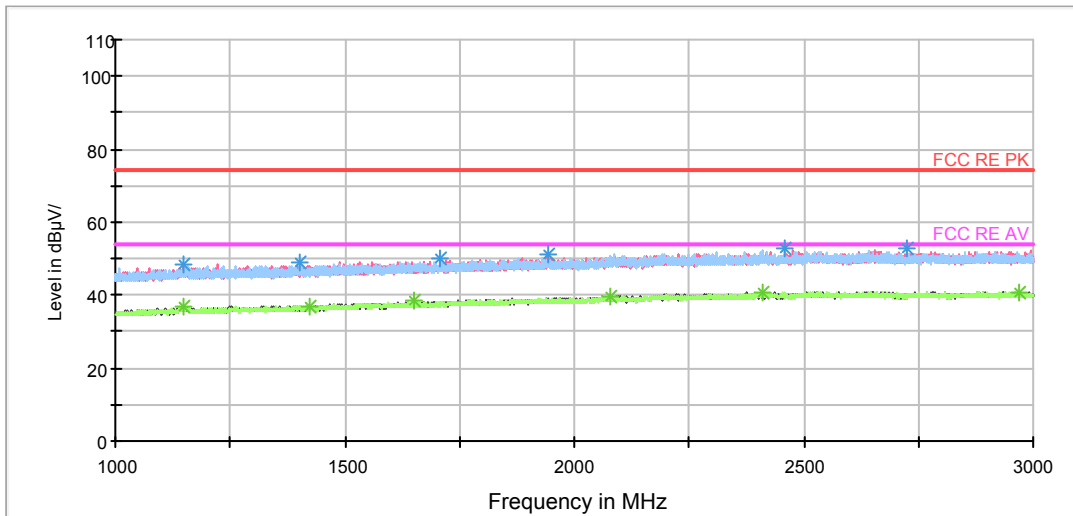

Radiates Emission from 1GHz to 3GHz

RE 3-18GHz PK+AV



Note: The signal beyond the limit is carrier.

Radiates Emission from 3GHz to 8GHz

RE 3-18GHz PK+AV

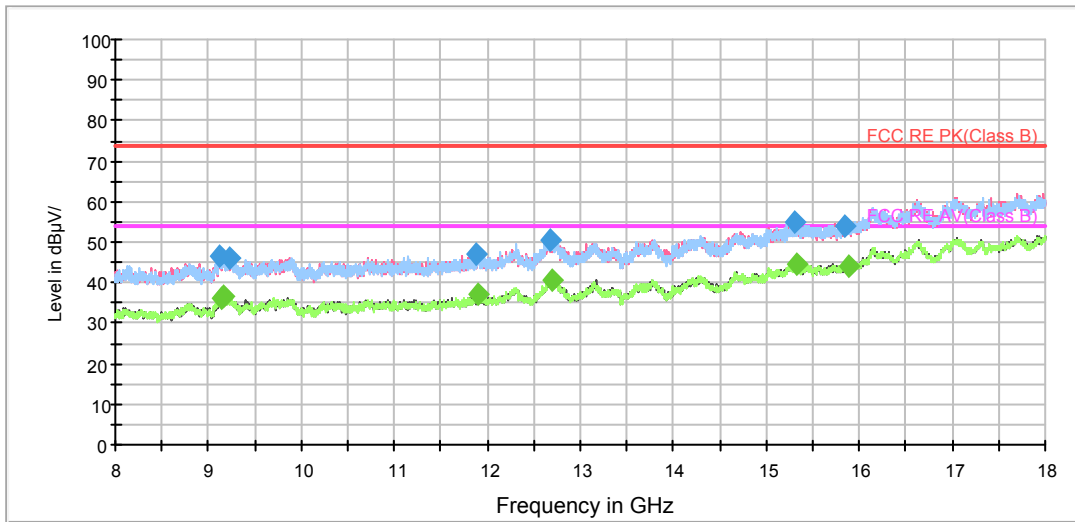

Radiates Emission from 8GHz to 18GHz

RE 18-26.5GHz PK+AV

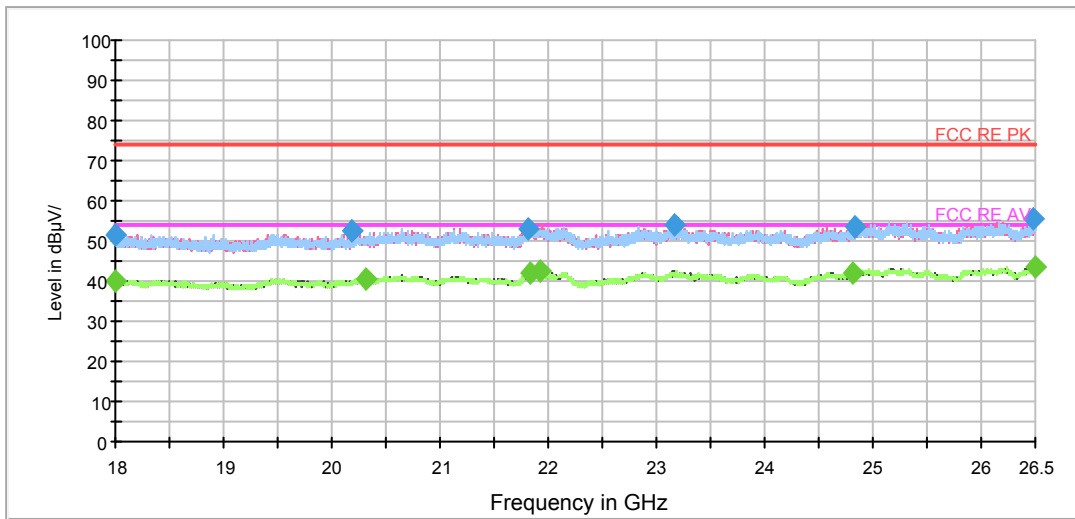

Radiates Emission from 18GHz to 26.5GHz

RE 26.5-40GHz PK+AV Class B

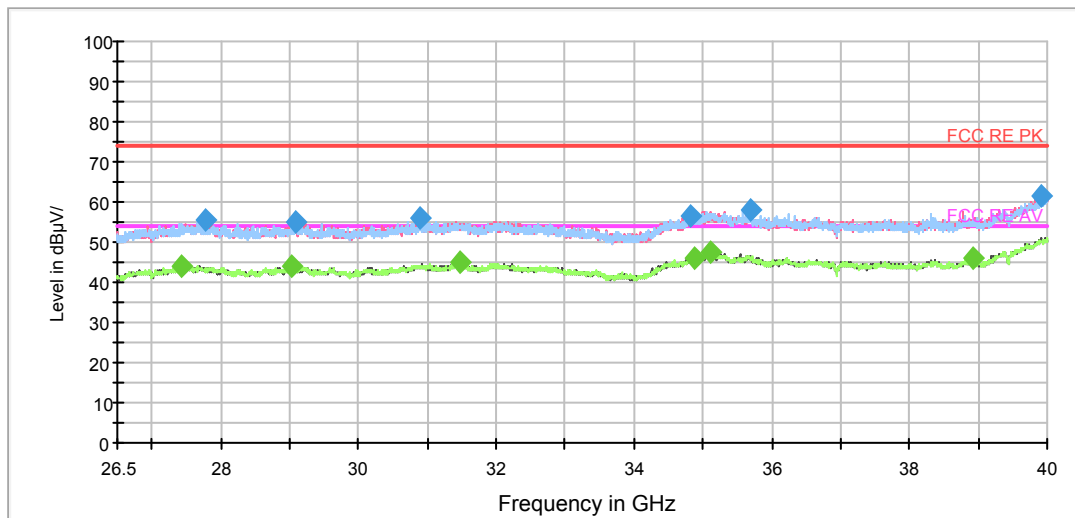

Radiates Emission from 26.5GHz to 40GHz

Frequency (MHz)	Peak (dBuV/m)	Height (cm)	Polarization	Azimuth (deg)	Reading value (dBuV/m)	Correct Factor (dB)	Margin (dB)	Limit (dBuV/m)
3366.875000	37.6	200.0	V	296.0	40.0	-2.4	36.4	74
4099.375000	38.5	200.0	V	285.0	39.5	-1.0	35.5	74
4690.000000	40.5	200.0	V	344.0	39.7	0.8	33.5	74
5913.125000	44.1	200.0	V	217.0	39.2	4.9	29.9	74
6647.500000	44.9	200.0	V	353.0	39.4	5.5	29.1	74
6905.000000	46.6	200.0	H	0.0	40.3	6.3	27.4	74

Remark: 1. Correction Factor = Antenna factor+ Insertion loss (cable loss + amplifier gain)

Frequency (MHz)	Average (dBuV/m)	Height (cm)	Polarization	Azimuth (deg)	Reading value (dBuV/m)	Correct Factor (dB)	Margin (dB)	Limit (dBuV/m)
3068.125000	27.7	200.0	H	0.0	30.8	-3.1	26.3	54
4056.250000	28.4	200.0	H	45.0	29.5	-1.1	25.6	54
4800.000000	30.6	200.0	V	296.0	29.3	1.3	23.4	54
5924.375000	33.5	200.0	V	119.0	28.7	4.8	20.5	54
6606.250000	34.5	200.0	V	236.0	28.9	5.6	19.5	54
7333.750000	38.2	200.0	H	142.0	31.2	7.0	15.8	54

Remark: 1. Correction Factor = Antenna factor+ Insertion loss (cable loss + amplifier gain)

802.11n (HT20) CH116

FCC RE 1G-3GHz PK+AV Class B

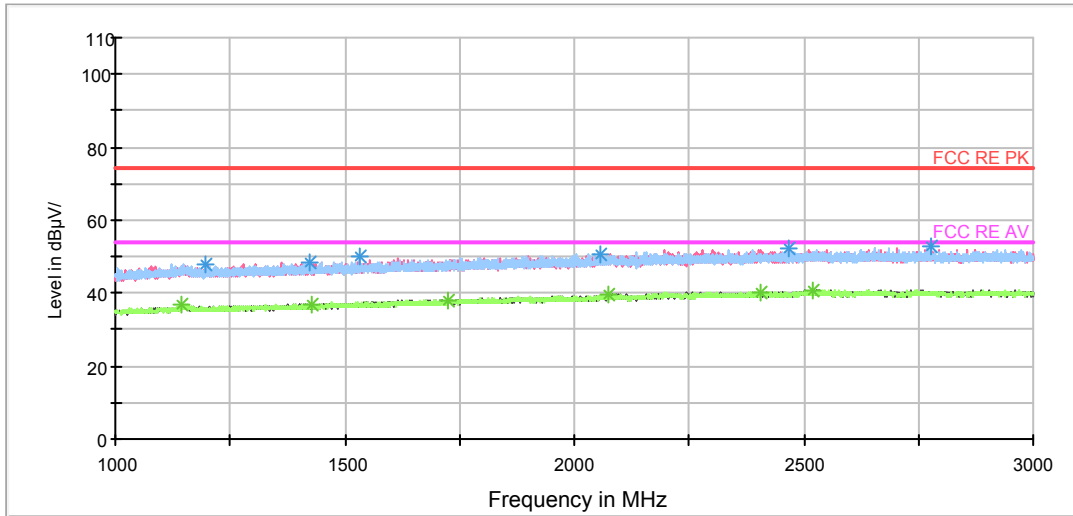

Radiates Emission from 1GHz to 3GHz

RE 3-18GHz PK+AV

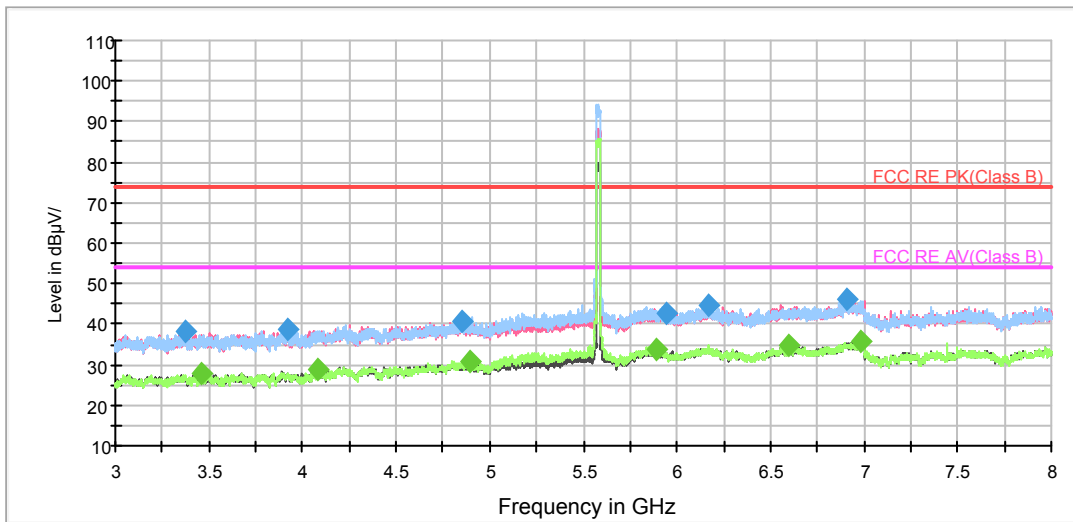

Note: The signal beyond the limit is carrier.

Radiates Emission from 3GHz to 8GHz

RE 3-18GHz PK+AV

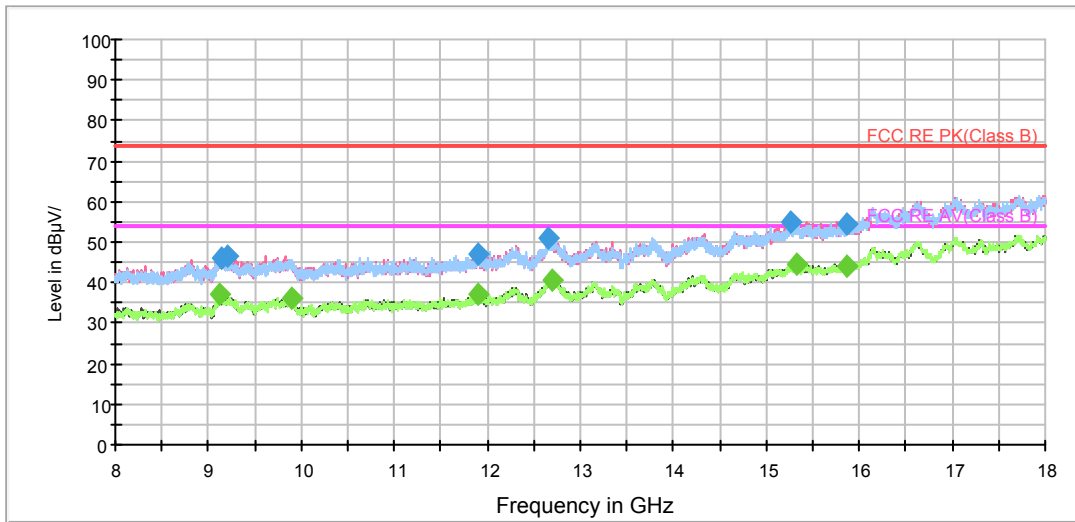

Radiates Emission from 8GHz to 18GHz

RE 18-26.5GHz PK+AV

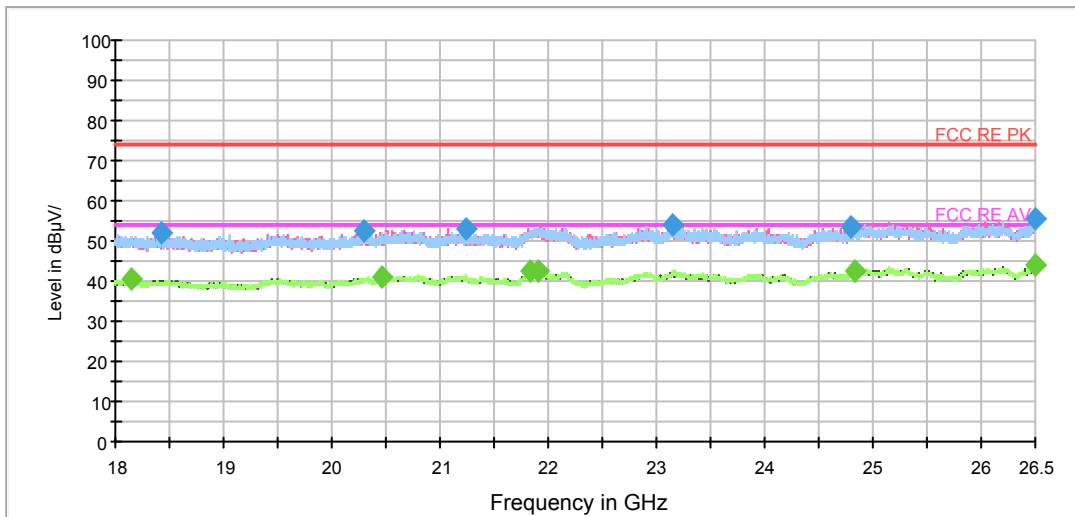

Radiates Emission from 18GHz to 26.5GHz

RE 26.5-40GHz PK+AV Class B

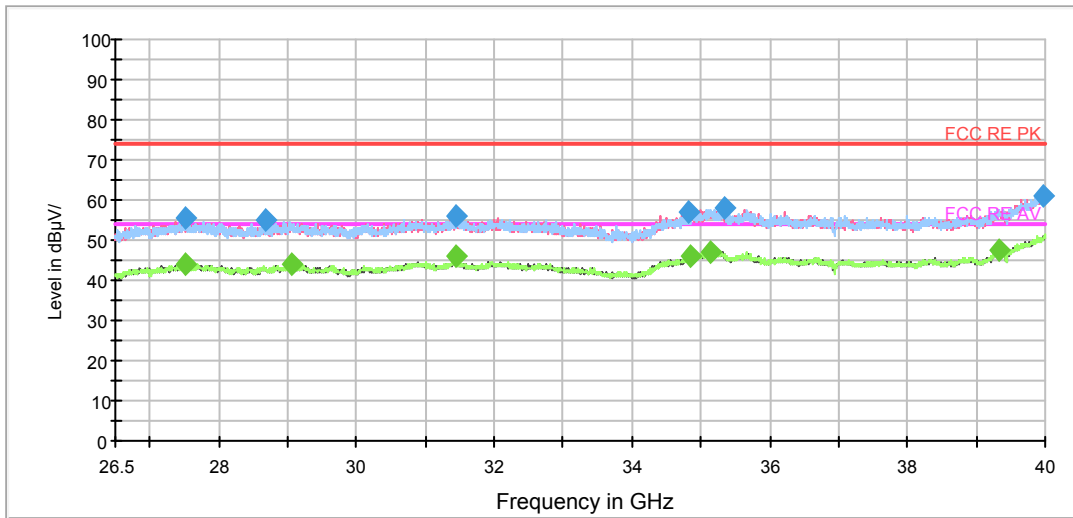

Radiates Emission from 26.5GHz to 40GHz

Frequency (MHz)	Peak (dBuV/m)	Height (cm)	Polarization	Azimuth (deg)	Reading value (dBuV/m)	Correct Factor (dB)	Margin (dB)	Limit (dBuV/m)
3371.250000	38.1	200.0	V	0.0	40.6	-2.5	35.9	74
3921.250000	38.6	200.0	H	96.0	39.8	-1.2	35.4	74
4848.750000	40.6	200.0	V	76.0	39.0	1.6	33.4	74
5948.125000	42.8	200.0	H	56.0	38.1	4.7	31.2	74
6172.500000	44.7	200.0	V	273.0	39.2	5.5	29.3	74
6913.125000	45.9	200.0	H	274.0	39.7	6.2	28.1	74

Remark: 1. Correction Factor = Antenna factor+ Insertion loss (cable loss + amplifier gain)

Frequency (MHz)	Average (dBuV/m)	Height (cm)	Polarization	Azimuth (deg)	Reading value (dBuV/m)	Correct Factor (dB)	Margin (dB)	Limit (dBuV/m)
3463.125000	27.7	200.0	H	126.0	29.9	-2.2	26.3	54
4076.875000	28.7	200.0	V	146.0	29.6	-0.9	25.3	54
4891.250000	30.7	200.0	H	233.0	28.8	1.9	23.3	54
5886.875000	33.5	200.0	H	338.0	28.6	4.9	20.5	54
6601.250000	34.9	200.0	H	67.0	29.2	5.7	19.1	54
6979.375000	35.7	200.0	H	86.0	29.4	6.3	18.3	54

Remark: 1. Correction Factor = Antenna factor+ Insertion loss (cable loss + amplifier gain)

802.11n (HT20) CH140

FCC RE 1G-3GHz PK+AV Class B

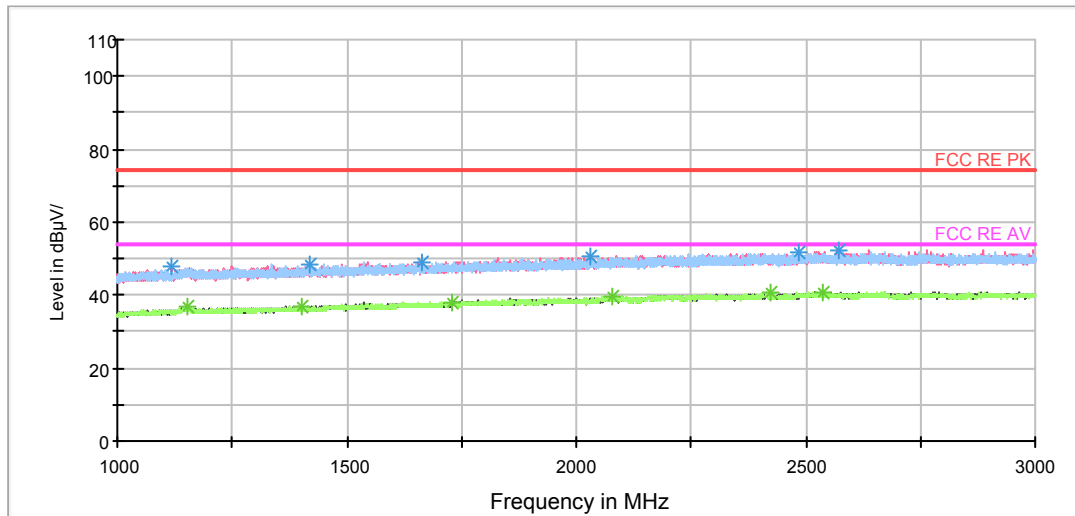

Radiates Emission from 1GHz to 3GHz

RE 3-18GHz PK+AV

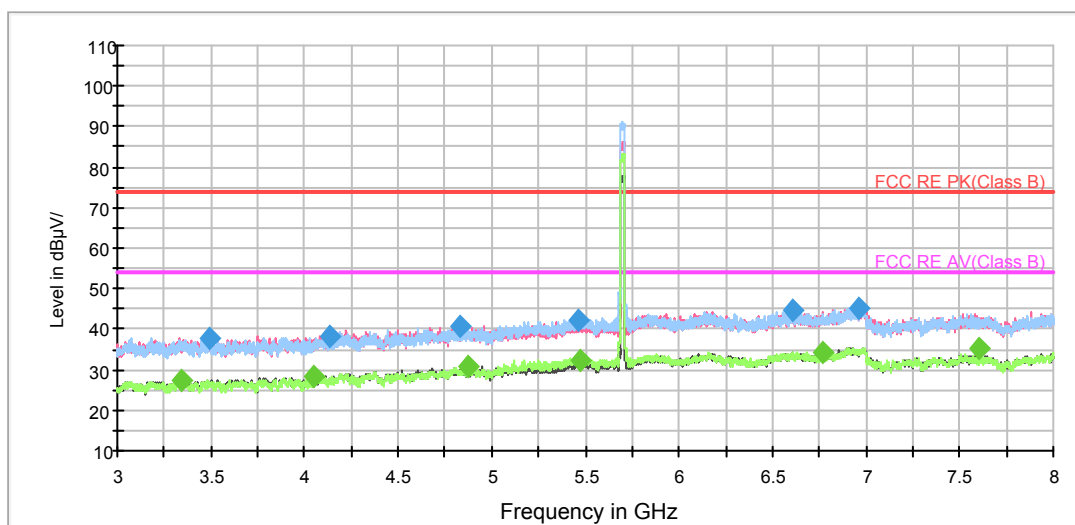

Note: The signal beyond the limit is carrier.

Radiates Emission from 3GHz to 8GHz

RE 3-18GHz PK+AV

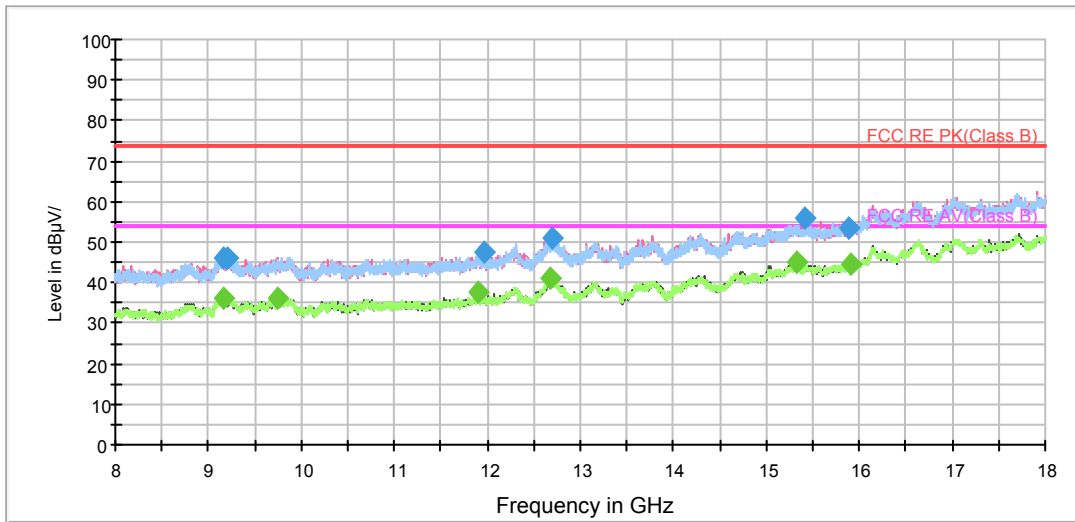

Radiates Emission from 8GHz to 18GHz

RE 18-26.5GHz PK+AV

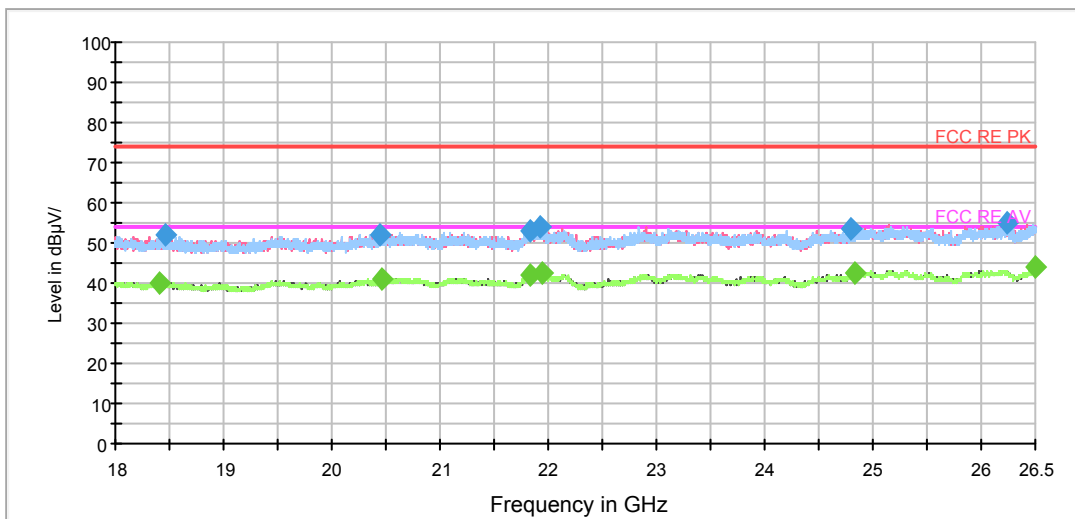

Radiates Emission from 18GHz to 26.5GHz

RE 26.5-40GHz PK+AV Class B

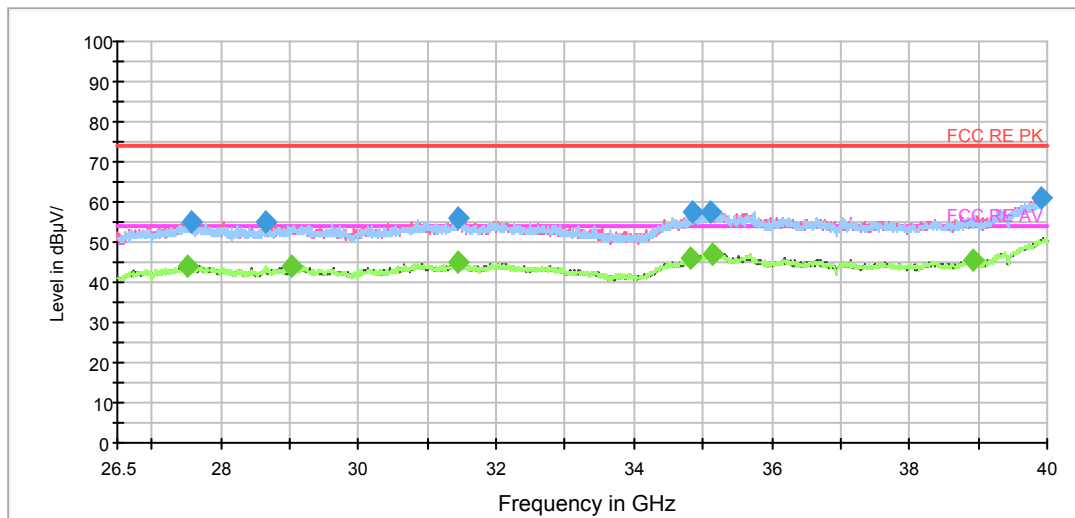

Radiates Emission from 26.5GHz to 40GHz

Frequency (MHz)	Peak (dBuV/m)	Height (cm)	Polarization	Azimuth (deg)	Reading value (dBuV/m)	Correct Factor (dB)	Margin (dB)	Limit (dBuV/m)
3496.875000	37.7	200.0	V	351.0	39.8	-2.1	36.3	74
4137.500000	38.2	200.0	V	351.0	38.5	-0.3	35.8	74
4832.500000	40.6	200.0	V	331.0	39.1	1.5	33.4	74
5464.375000	42.0	200.0	V	252.0	39.2	2.8	32.0	74
6613.125000	44.7	200.0	H	94.0	39.2	5.5	29.3	74
6959.375000	45.4	200.0	H	6.0	39.2	6.2	28.6	74

Remark: 1. Correction Factor = Antenna factor+ Insertion loss (cable loss + amplifier gain)

Frequency (MHz)	Average (dBuV/m)	Height (cm)	Polarization	Azimuth (deg)	Reading value (dBuV/m)	Correct Factor (dB)	Margin (dB)	Limit (dBuV/m)
3341.250000	27.4	200.0	V	359.0	29.8	-2.4	26.6	54
4051.250000	28.1	200.0	V	341.0	29.2	-1.1	25.9	54
4876.875000	30.6	200.0	V	272.0	28.8	1.8	23.4	54
5476.875000	32.5	200.0	H	84.0	29.5	3.0	21.5	54
6771.250000	34.3	200.0	H	172.0	28.8	5.5	19.7	54
7600.625000	35.4	200.0	H	114.0	28.4	7.0	18.6	54

Remark: 1. Correction Factor = Antenna factor+ Insertion loss (cable loss + amplifier gain)

802.11n (HT20) CH149

FCC RE 1G-3GHz PK+AV Class B

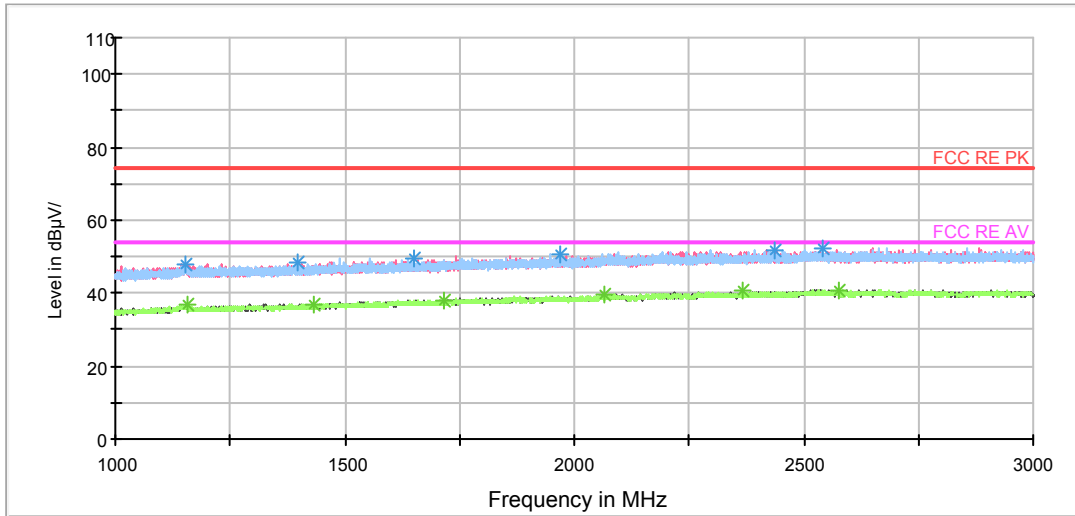

Radiates Emission from 1GHz to 3GHz

RE 3-18GHz PK+AV

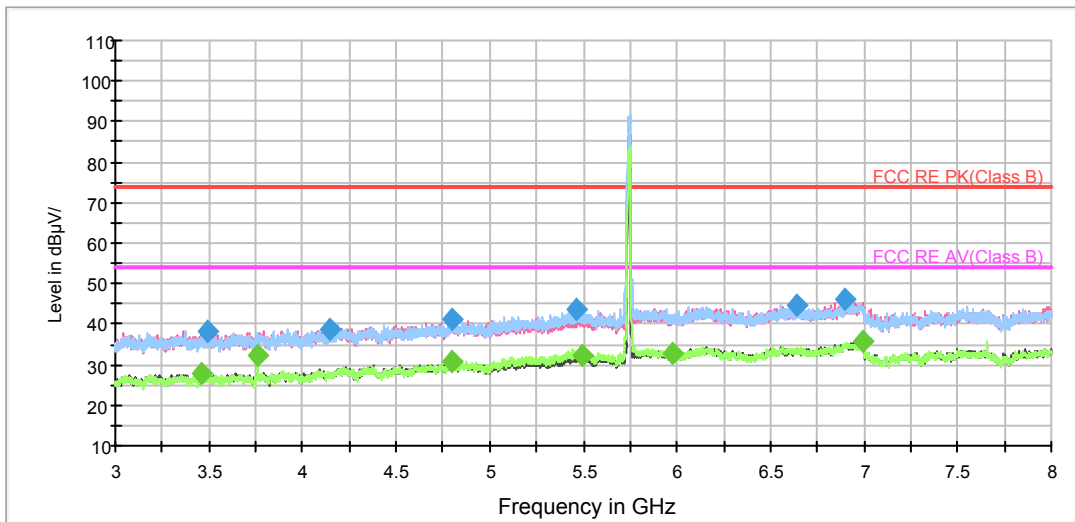

Note: The signal beyond the limit is carrier.

Radiates Emission from 3GHz to 8GHz

RE 3-18GHz PK+AV

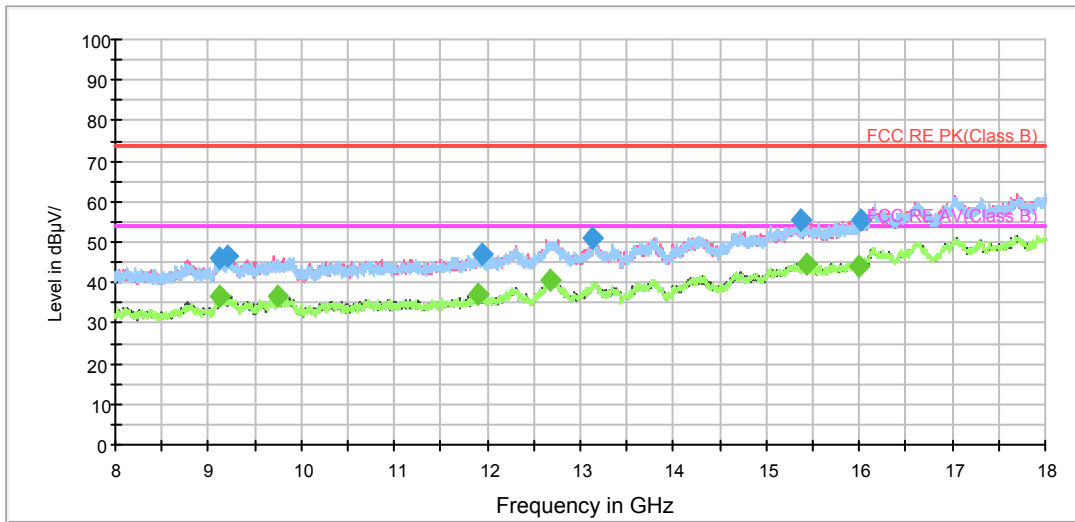

Radiates Emission from 8GHz to 18GHz

RE 18-26.5GHz PK+AV

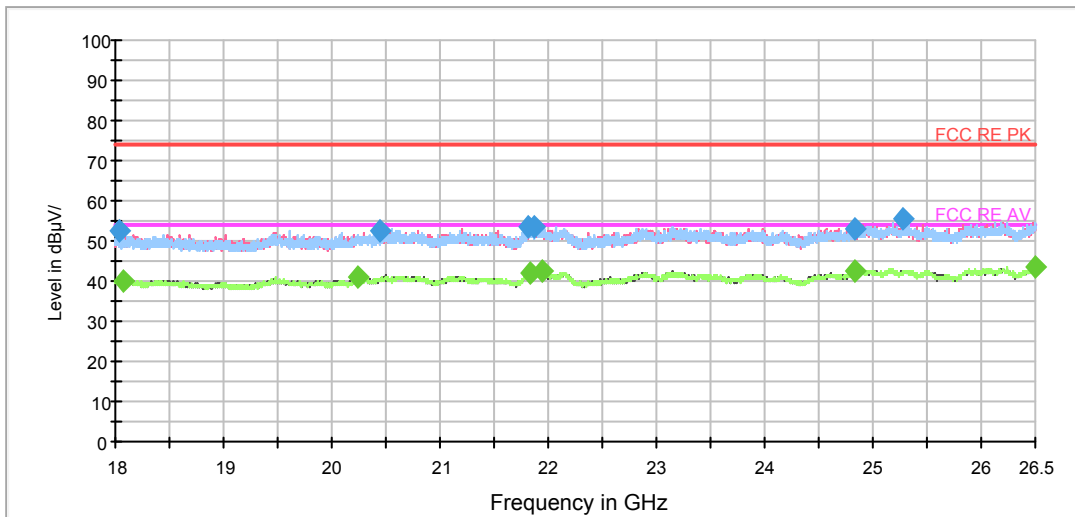

Radiates Emission from 18GHz to 26.5GHz

RE 26.5-40GHz PK+AV Class B

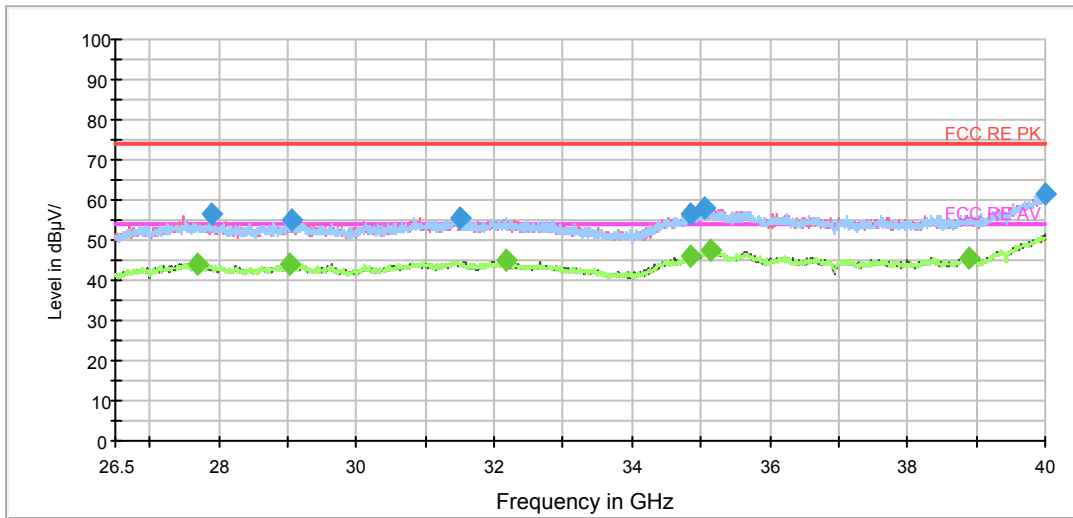

Radiates Emission from 26.5GHz to 40GHz

Frequency (MHz)	Peak (dBuV/m)	Height (cm)	Polarization	Azimuth (deg)	Reading value (dBuV/m)	Correct Factor (dB)	Margin (dB)	Limit (dBuV/m)
3487.500000	38.4	200.0	V	198.0	40.4	-2.0	35.6	74
4143.750000	38.8	200.0	V	0.0	39.0	-0.2	35.2	74
4799.375000	41.0	200.0	V	208.0	39.7	1.3	33.0	74
5459.375000	43.7	200.0	H	0.0	40.9	2.8	30.3	74
6640.625000	44.8	200.0	H	0.0	39.3	5.5	29.2	74
6902.500000	45.9	200.0	V	308.0	39.6	6.3	28.1	74

Remark: 1. Correction Factor = Antenna factor+ Insertion loss (cable loss + amplifier gain)

Frequency (MHz)	Average (dBuV/m)	Height (cm)	Polarization	Azimuth (deg)	Reading value (dBuV/m)	Correct Factor (dB)	Margin (dB)	Limit (dBuV/m)
3457.500000	27.8	200.0	V	0.0	30.0	-2.2	26.2	54
3760.000000	32.4	200.0	H	295.0	34.0	-1.6	21.6	54
4803.750000	30.9	200.0	H	0.0	29.6	1.3	23.1	54
5496.250000	32.5	200.0	H	0.0	29.4	3.1	21.5	54
5974.375000	32.7	200.0	V	358.0	28.0	4.7	21.3	54
6989.375000	35.8	200.0	V	348.0	29.4	6.4	18.2	54

Remark: 1. Correction Factor = Antenna factor+ Insertion loss (cable loss + amplifier gain)

802.11n (HT20) CH157

FCC RE 1G-3GHz PK+AV Class B

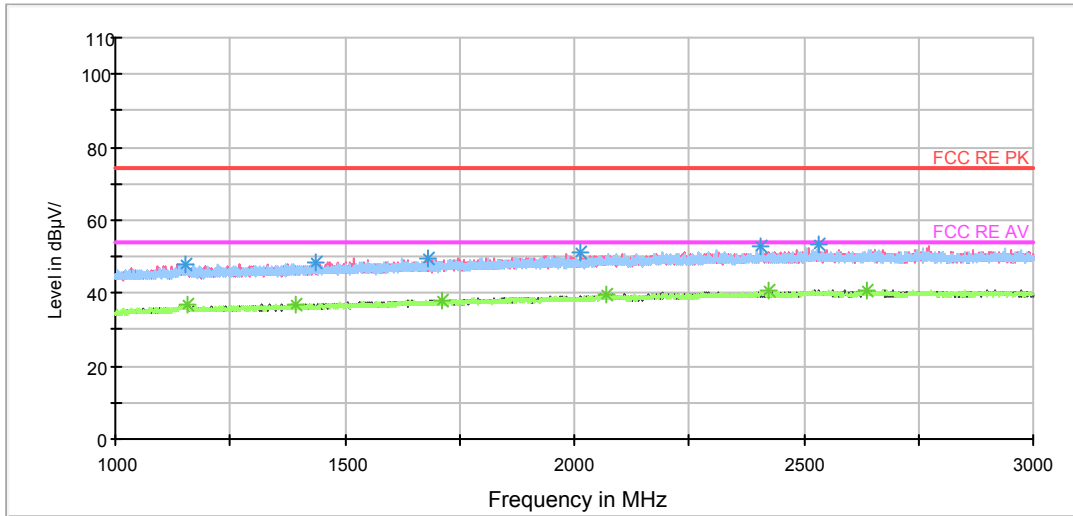

Radiates Emission from 1GHz to 3GHz

RE 3-18GHz PK+AV

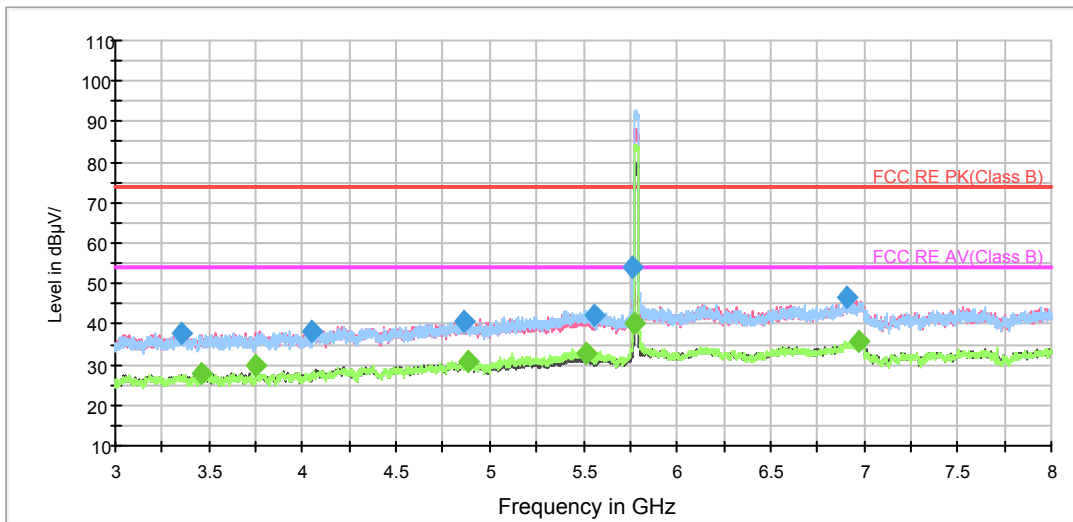

Note: The signal beyond the limit is carrier.

Radiates Emission from 3GHz to 8GHz

RE 3-18GHz PK+AV

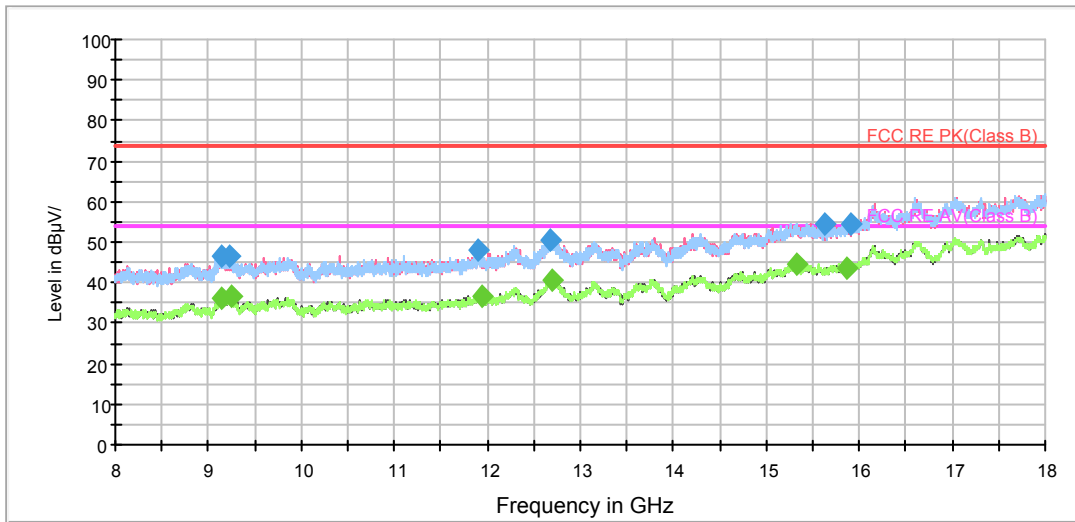

Radiates Emission from 8GHz to 18GHz

RE 18-26.5GHz PK+AV

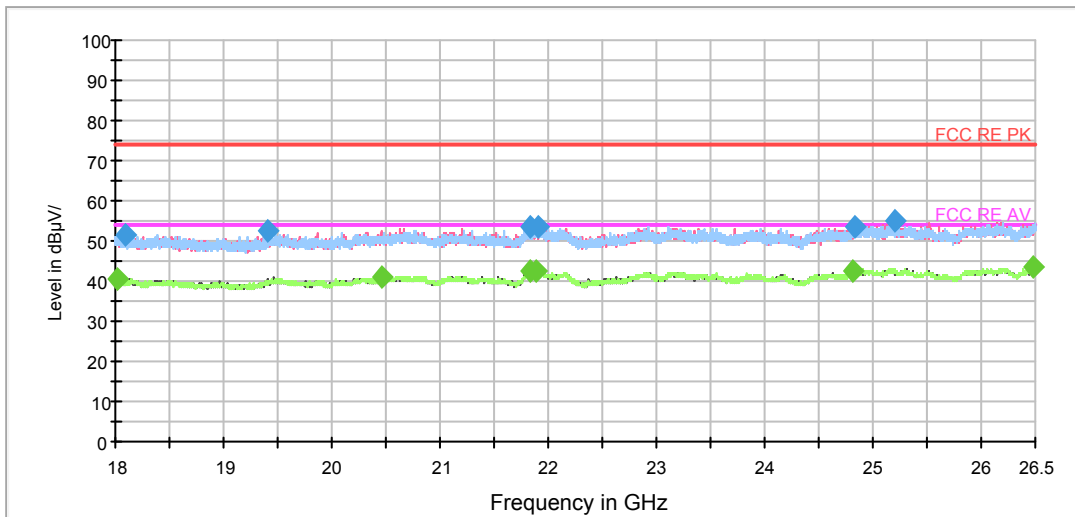

Radiates Emission from 18GHz to 26.5GHz

RE 26.5-40GHz PK+AV Class B

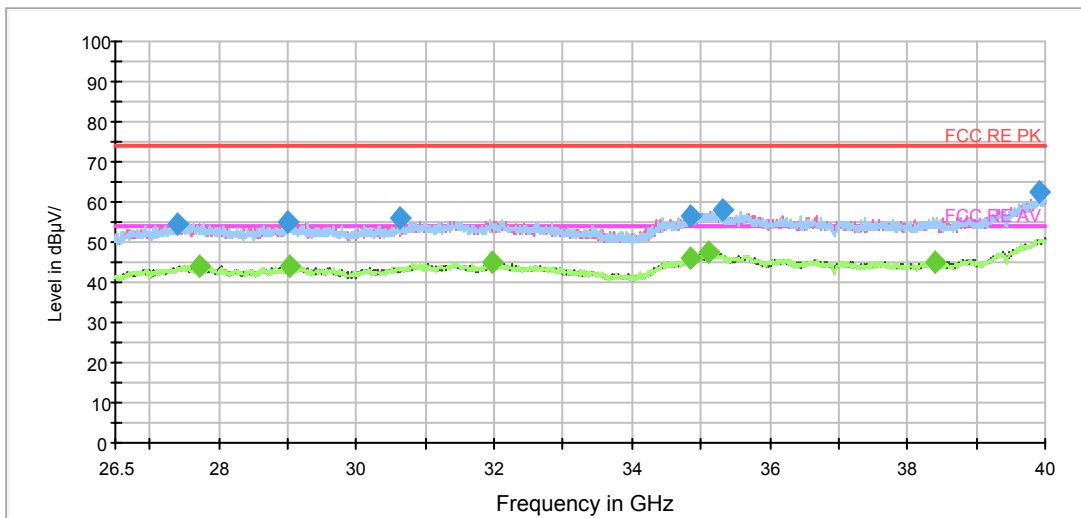

Radiates Emission from 26.5GHz to 40GHz

Frequency (MHz)	Peak (dBuV/m)	Height (cm)	Polarization	Azimuth (deg)	Reading value (dBuV/m)	Correct Factor (dB)	Margin (dB)	Limit (dBuV/m)
3355.000000	37.6	200.0	H	65.0	39.9	-2.3	36.4	74
4054.375000	38.2	200.0	H	7.0	39.3	-1.1	35.8	74
4860.000000	40.5	200.0	V	56.0	38.8	1.7	33.5	74
5555.000000	42.2	200.0	H	36.0	39.0	3.2	31.8	74
5766.250000	54.3	200.0	H	26.0	50.6	3.7	19.7	74
6908.750000	46.6	200.0	V	357.0	40.4	6.2	27.4	74

Remark: 1. Correction Factor = Antenna factor+ Insertion loss (cable loss + amplifier gain)

Frequency (MHz)	Average (dBuV/m)	Height (cm)	Polarization	Azimuth (deg)	Reading value (dBuV/m)	Correct Factor (dB)	Margin (dB)	Limit (dBuV/m)
3456.250000	27.7	200.0	V	269.0	29.9	-2.2	26.3	54
3752.500000	29.6	200.0	H	125.0	31.3	-1.7	24.4	54
4888.750000	30.8	200.0	H	85.0	28.9	1.9	23.2	54
5521.250000	32.8	200.0	H	36.0	29.7	3.1	21.2	54
5768.750000	40.1	200.0	H	36.0	36.4	3.7	13.9	54
6976.250000	35.7	200.0	H	0.0	29.4	6.3	18.3	54

Remark: 1. Correction Factor = Antenna factor+ Insertion loss (cable loss + amplifier gain)

802.11n (HT20) CH165

FCC RE 1G-3GHz PK+AV Class B

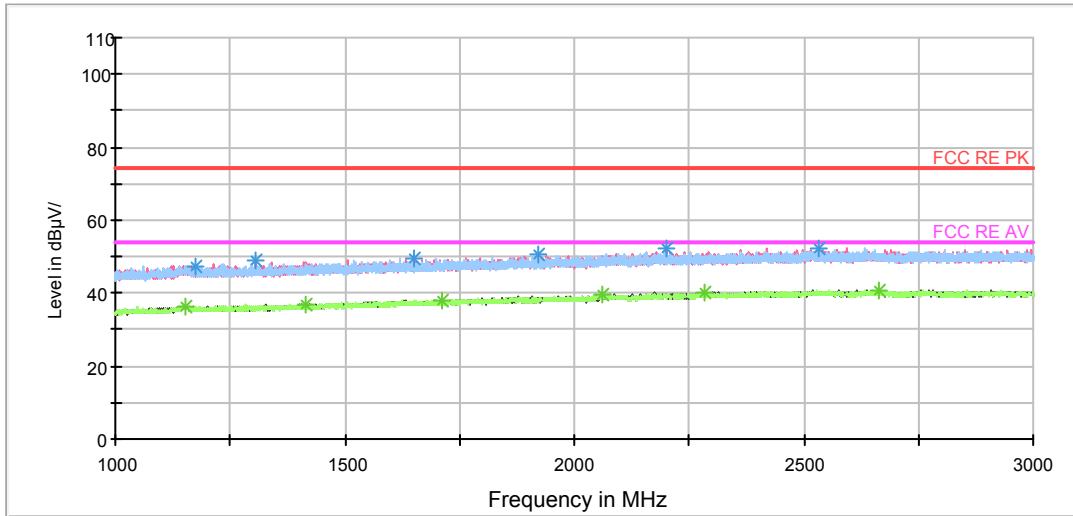

Radiates Emission from 1GHz to 3GHz

RE 3-18GHz PK+AV

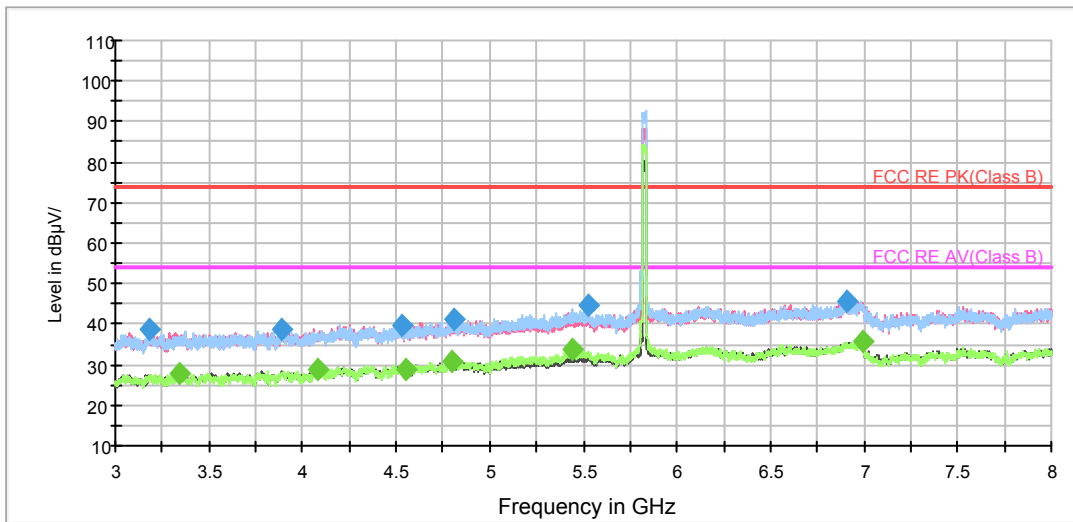

Note: The signal beyond the limit is carrier.

Radiates Emission from 3GHz to 8GHz

RE 3-18GHz PK+AV

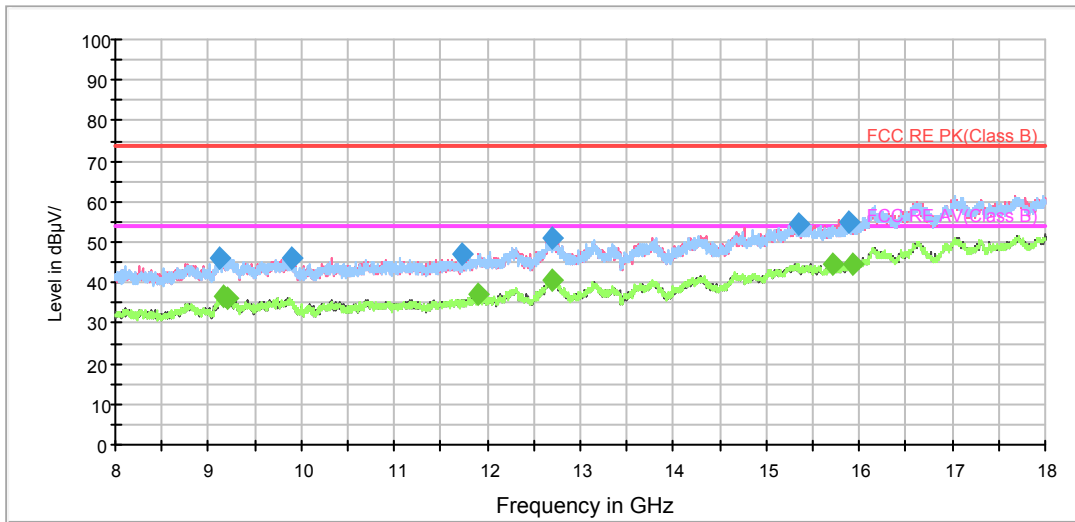

Radiates Emission from 8GHz to 18GHz

RE 18-26.5GHz PK+AV

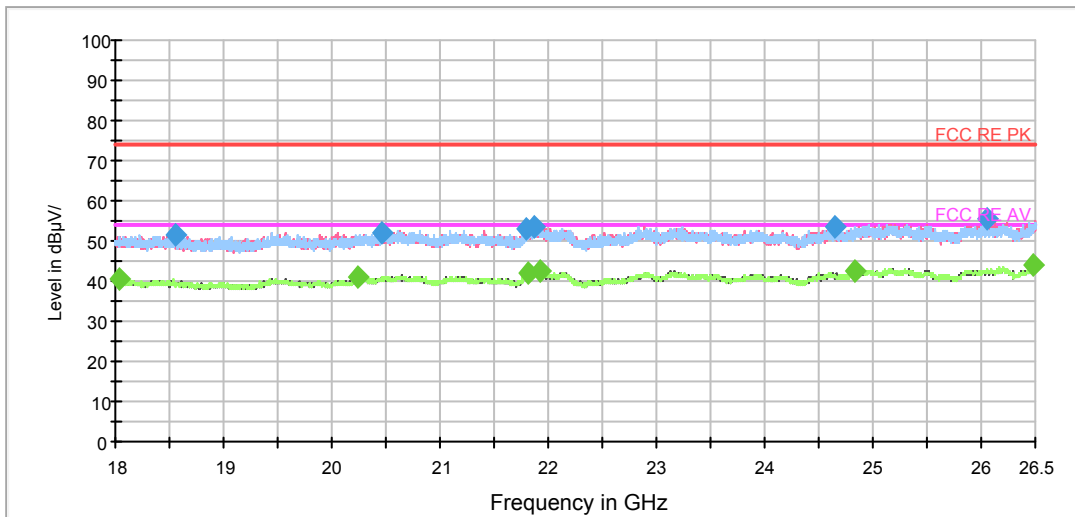

Radiates Emission from 18GHz to 26.5GHz

RE 26.5-40GHz PK+AV Class B

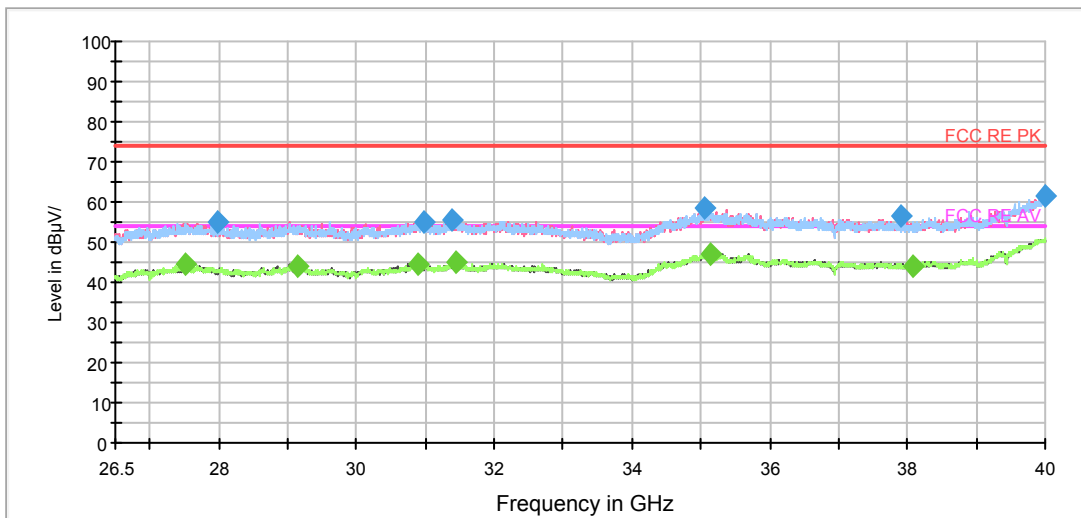

Radiates Emission from 26.5GHz to 40GHz

Frequency (MHz)	Peak (dBuV/m)	Height (cm)	Polarization	Azimuth (deg)	Reading value (dBuV/m)	Correct Factor (dB)	Margin (dB)	Limit (dBuV/m)
3179.375000	38.5	200.0	H	145.0	41.4	-2.9	35.5	74
3891.250000	38.9	200.0	H	124.0	40.2	-1.3	35.1	74
4531.875000	39.5	200.0	V	286.0	38.9	0.6	34.5	74
4805.625000	41.2	200.0	V	217.0	39.9	1.3	32.8	74
5531.250000	44.5	200.0	H	38.0	41.3	3.2	29.5	74
6908.125000	45.8	200.0	V	207.0	39.6	6.2	28.2	74

Remark: 1. Correction Factor = Antenna factor+ Insertion loss (cable loss + amplifier gain)

Frequency (MHz)	Average (dBuV/m)	Height (cm)	Polarization	Azimuth (deg)	Reading value (dBuV/m)	Correct Factor (dB)	Margin (dB)	Limit (dBuV/m)
3345.625000	27.8	200.0	V	207.0	30.1	-2.3	26.2	54
4083.125000	28.7	200.0	H	95.0	29.6	-0.9	25.3	54
4555.000000	28.9	200.0	V	266.0	28.0	0.9	25.1	54
4799.375000	30.7	200.0	H	0.0	29.4	1.3	23.3	54
5440.000000	33.7	200.0	H	0.0	30.8	2.9	20.3	54
6998.125000	35.7	200.0	V	246.0	29.2	6.5	18.3	54

Remark: 1. Correction Factor = Antenna factor+ Insertion loss (cable loss + amplifier gain)

802.11n (HT40) CH38

FCC RE 1G-3GHz PK+AV Class B

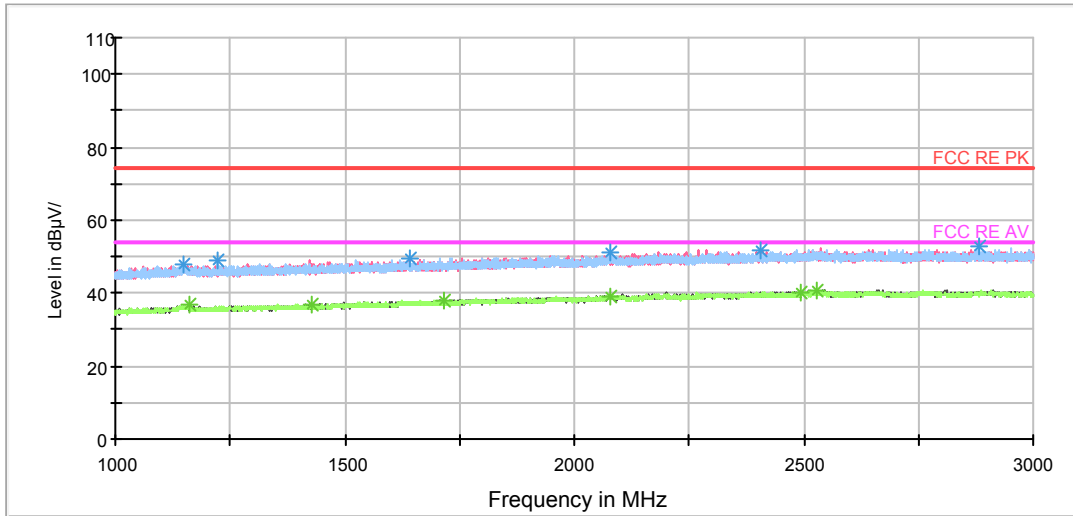

Radiates Emission from 1GHz to 3GHz

RE 3-18GHz AV

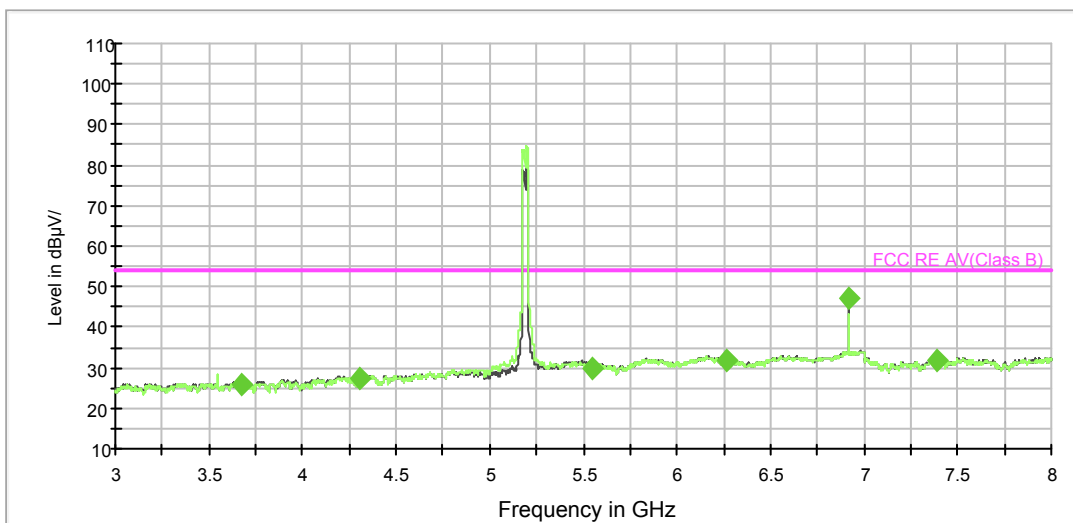

RE 3-18GHz PK+AV

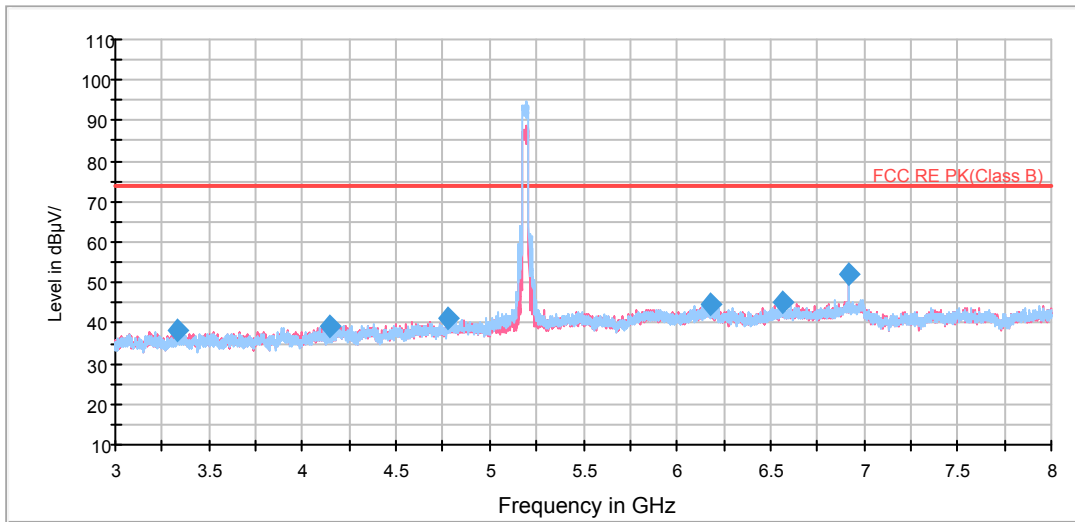

Note: The signal beyond the limit is carrier.
Radiates Emission from 3GHz to 8GHz

RE 3-18GHz PK+AV

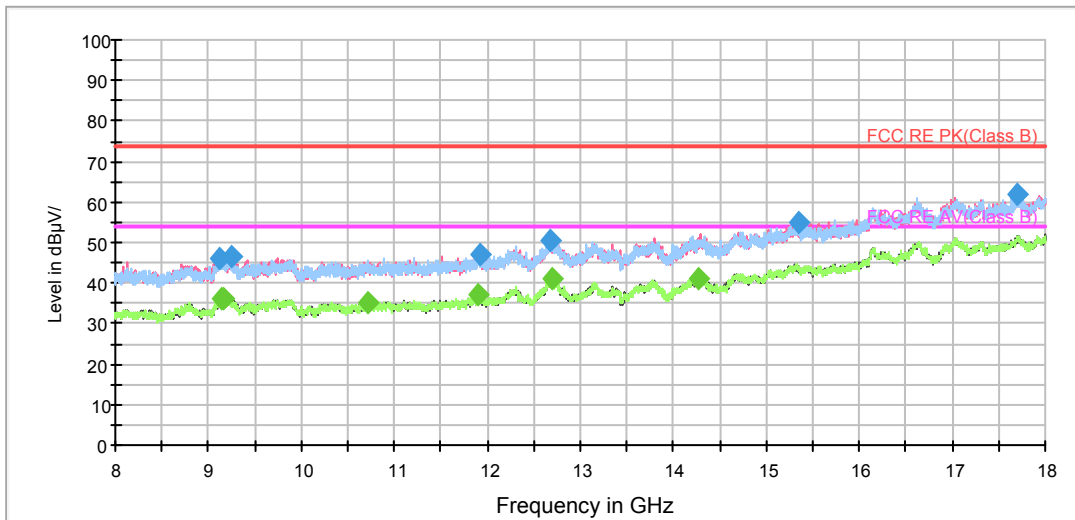

Radiates Emission from 8GHz to 18GHz

RE 18-26.5GHz PK+AV

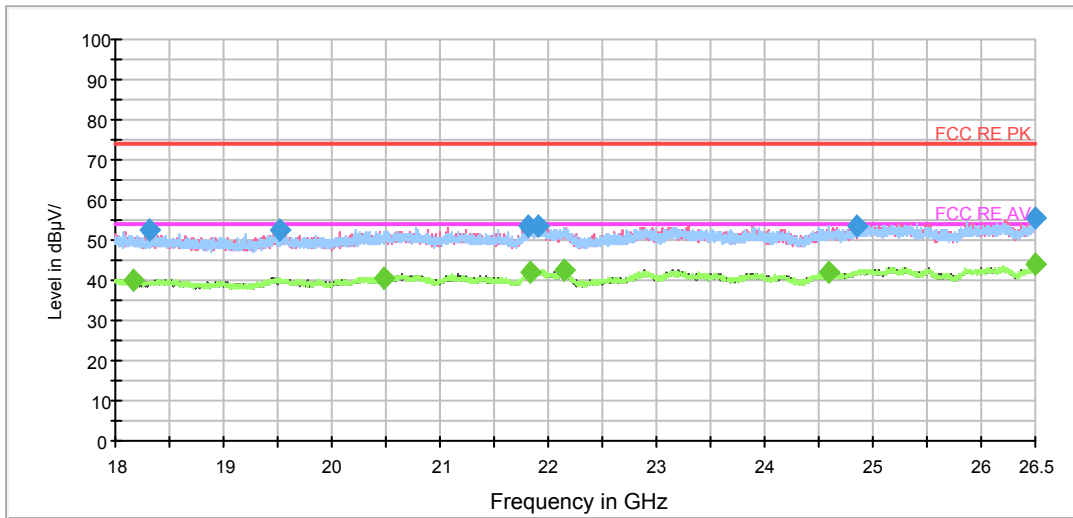

Radiates Emission from 18GHz to 26.5GHz

RE 26.5-40GHz PK+AV Class B

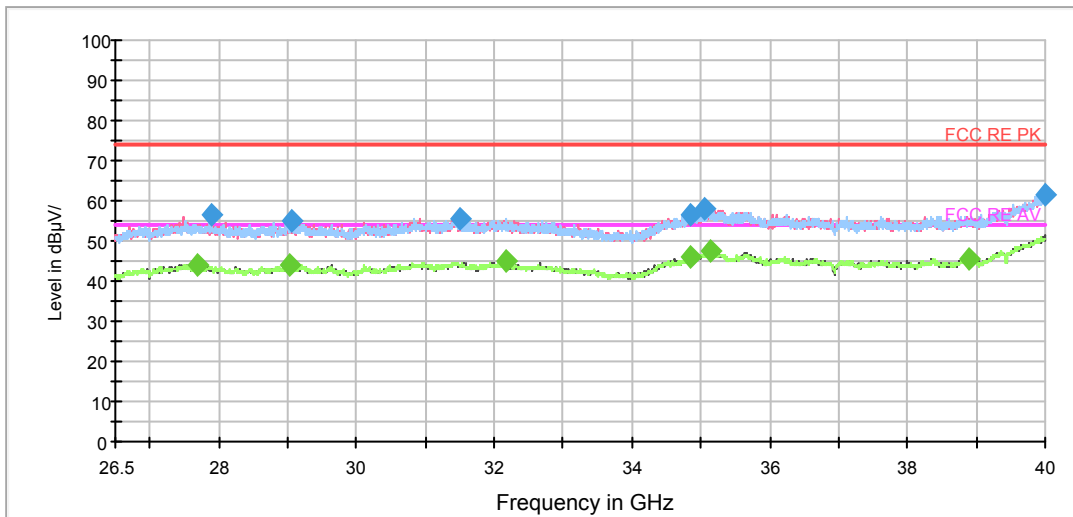

Radiates Emission from 26.5GHz to 40GHz

Frequency (MHz)	Peak (dBuV/m)	Height (cm)	Polarization	Azimuth (deg)	Reading value (dBuV/m)	Correct Factor (dB)	Margin (dB)	Limit (dBuV/m)
3334.375000	38.1	200.0	V	298.0	40.4	-2.3	35.9	74
4149.375000	39.0	200.0	V	267.0	39.2	-0.2	35.0	74
4775.000000	41.0	200.0	V	354.0	39.9	1.1	33.0	74
6185.000000	44.5	200.0	V	335.0	39.1	5.4	29.5	74
6567.500000	45.1	200.0	V	277.0	39.4	5.7	28.9	74
6920.625000	52.2	200.0	H	338.0	46.0	6.2	21.8	74

Remark: 1. Correction Factor = Antenna factor+ Insertion loss (cable loss + amplifier gain)



Frequency (MHz)	Average (dBuV/m)	Height (cm)	Polarization	Azimuth (deg)	Reading value (dBuV/m)	Correct Factor (dB)	Margin (dB)	Limit (dBuV/m)
3670.000000	25.7	200.0	V	0.0	27.5	-1.8	28.3	54
4302.500000	27.1	200.0	V	249.0	26.3	0.8	26.9	54
5553.125000	30.0	200.0	V	0.0	26.8	3.2	24.0	54
6260.625000	31.6	200.0	V	0.0	26.1	5.5	22.4	54
6920.000000	47.1	200.0	V	0.0	40.9	6.2	6.9	54
7389.375000	31.7	200.0	V	0.0	24.8	6.9	22.3	54

Remark: 1. Correction Factor = Antenna factor+ Insertion loss (cable loss + amplifier gain)

802.11n (HT40) CH46

FCC RE 1G-3GHz PK+AV Class B

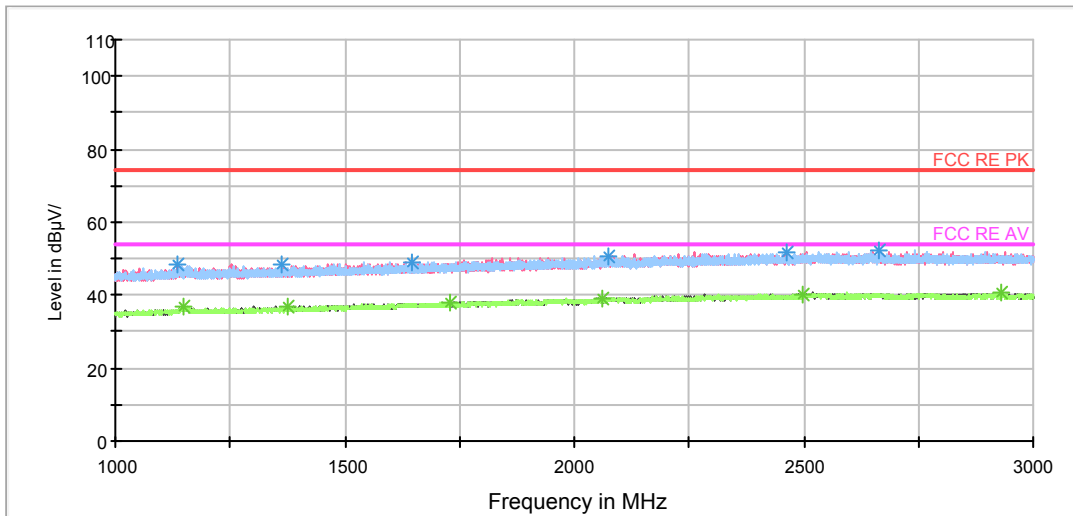

Radiates Emission from 1GHz to 3GHz

RE 3-18GHz PK+AV

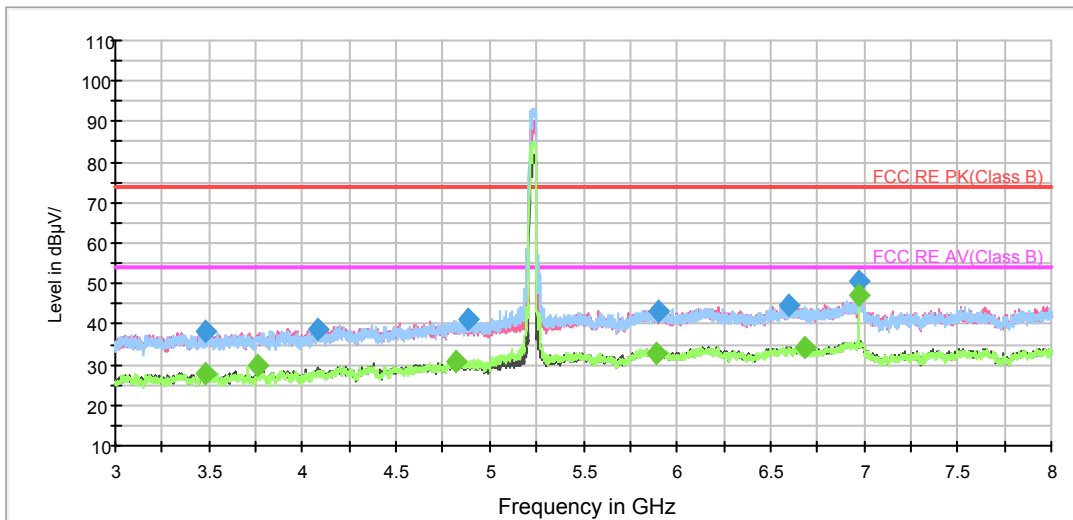

Note: The signal beyond the limit is carrier.

Radiates Emission from 3GHz to 8GHz

RE 3-18GHz PK+AV

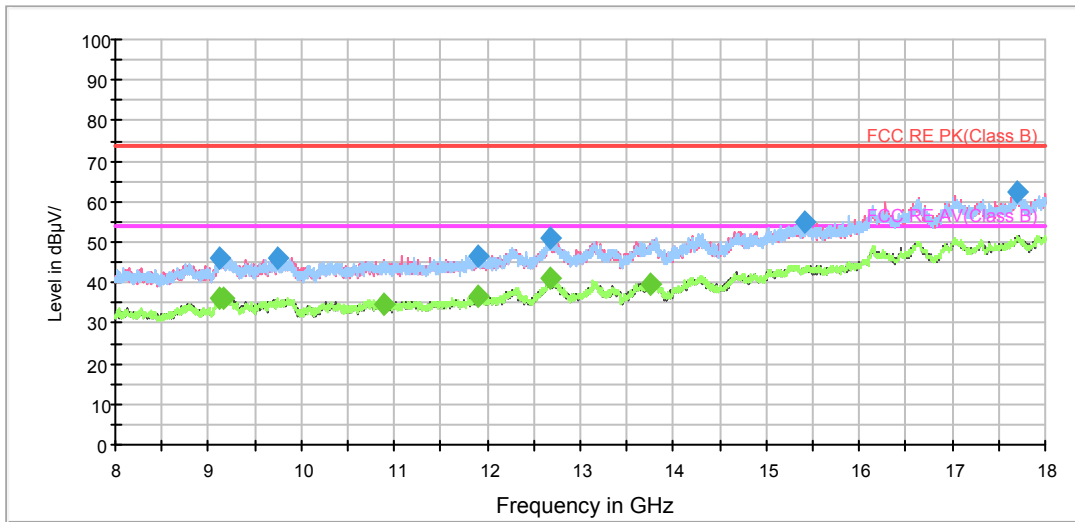

Radiates Emission from 8GHz to 18GHz

RE 18-26.5GHz PK+AV

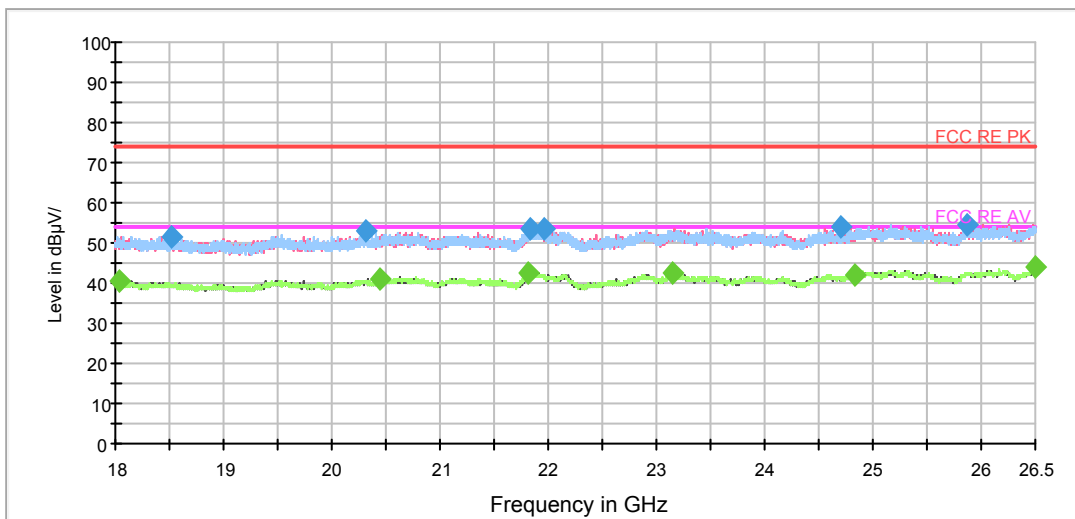

Radiates Emission from 18GHz to 26.5GHz

RE 26.5-40GHz PK+AV Class B

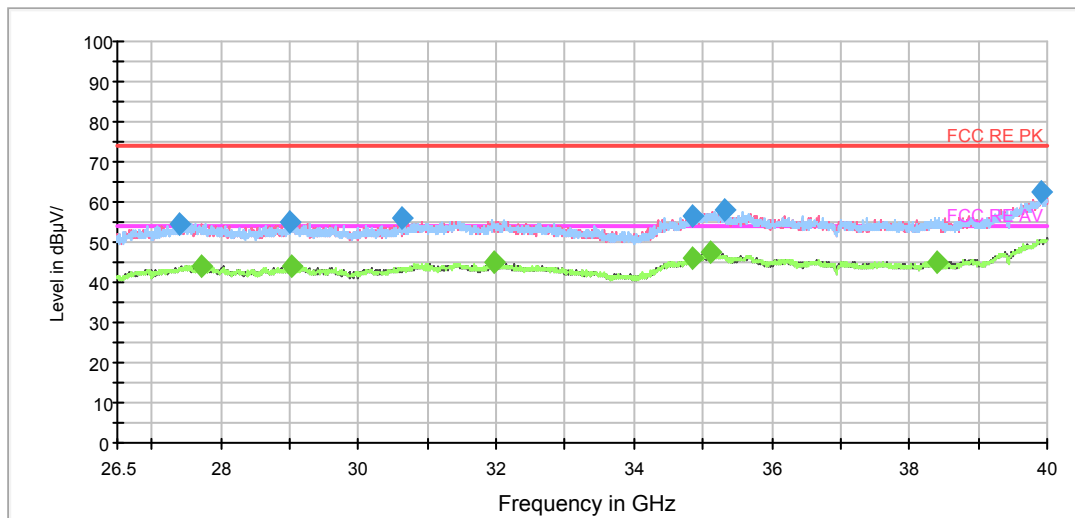

Radiates Emission from 26.5GHz to 40GHz

Frequency (MHz)	Peak (dBuV/m)	Height (cm)	Polarization	Azimuth (deg)	Reading value (dBuV/m)	Correct Factor (dB)	Margin (dB)	Limit (dBuV/m)
3483.750000	38.2	200.0	V	294.0	40.2	-2.0	35.8	74
4078.750000	38.7	200.0	V	333.0	39.6	-0.9	35.3	74
4883.125000	41.4	200.0	V	283.0	39.5	1.9	32.6	74
5897.500000	43.2	200.0	H	39.0	38.3	4.9	30.8	74
6602.500000	44.5	200.0	V	353.0	38.8	5.7	29.5	74
6973.750000	50.7	200.0	H	337.0	44.4	6.3	23.3	74

Remark: 1. Correction Factor = Antenna factor+ Insertion loss (cable loss + amplifier gain)

Frequency (MHz)	Average (dBuV/m)	Height (cm)	Polarization	Azimuth (deg)	Reading value (dBuV/m)	Correct Factor (dB)	Margin (dB)	Limit (dBuV/m)
3486.875000	27.8	200.0	H	264.0	29.8	-2.0	26.2	54
3758.750000	29.7	200.0	H	1.0	31.3	-1.6	24.3	54
4816.875000	31.0	200.0	H	109.0	29.7	1.3	23.0	54
5893.750000	33.0	200.0	V	190.0	28.1	4.9	21.0	54
6686.875000	34.5	200.0	V	273.0	29.1	5.4	19.5	54
6973.750000	47.2	200.0	V	353.0	40.9	6.3	6.8	54

Remark: 1. Correction Factor = Antenna factor+ Insertion loss (cable loss + amplifier gain)

802.11n (HT40) CH54

FCC RE 1G-3GHz PK+AV Class B

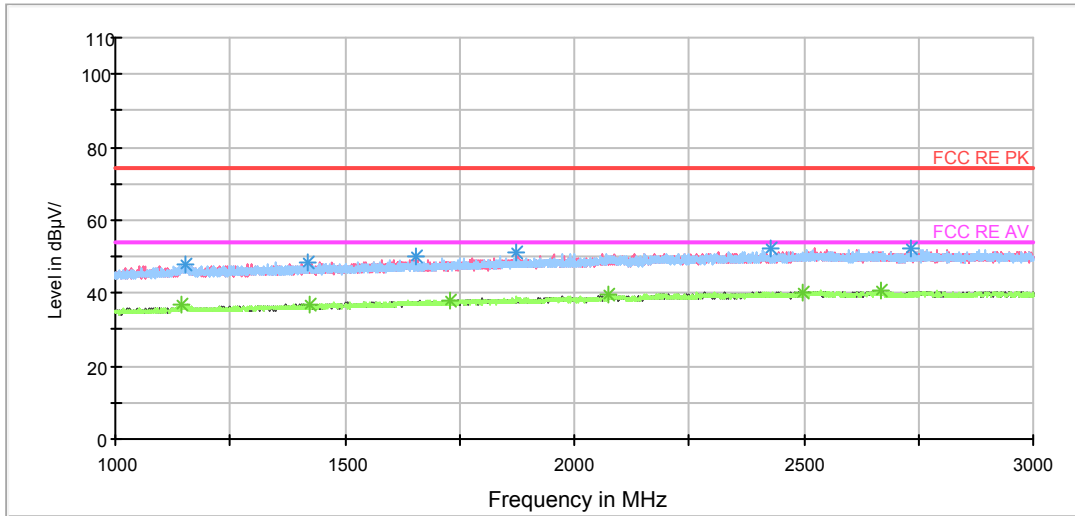

Radiates Emission from 1GHz to 3GHz

RE 3-18GHz AV

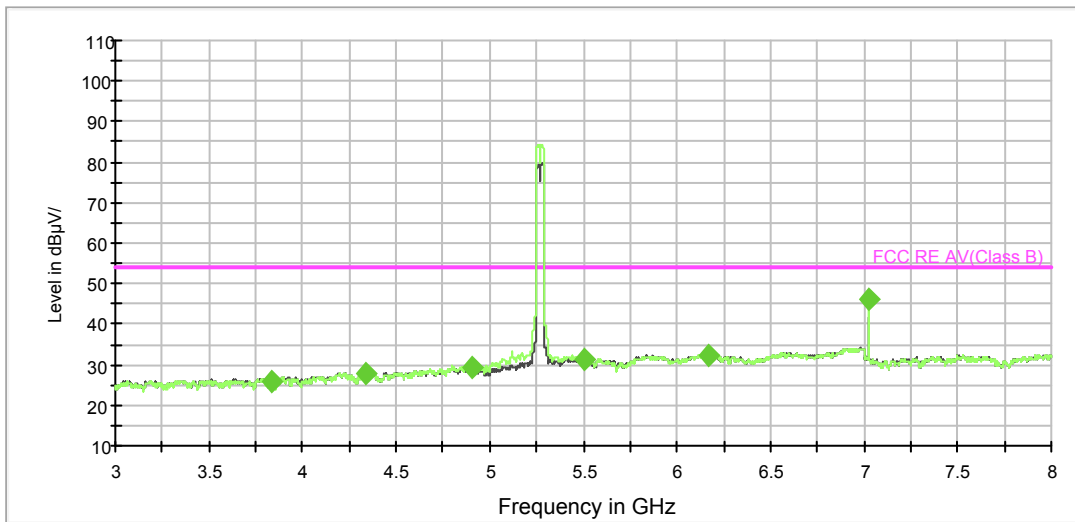

RE 3-18GHz PK+AV

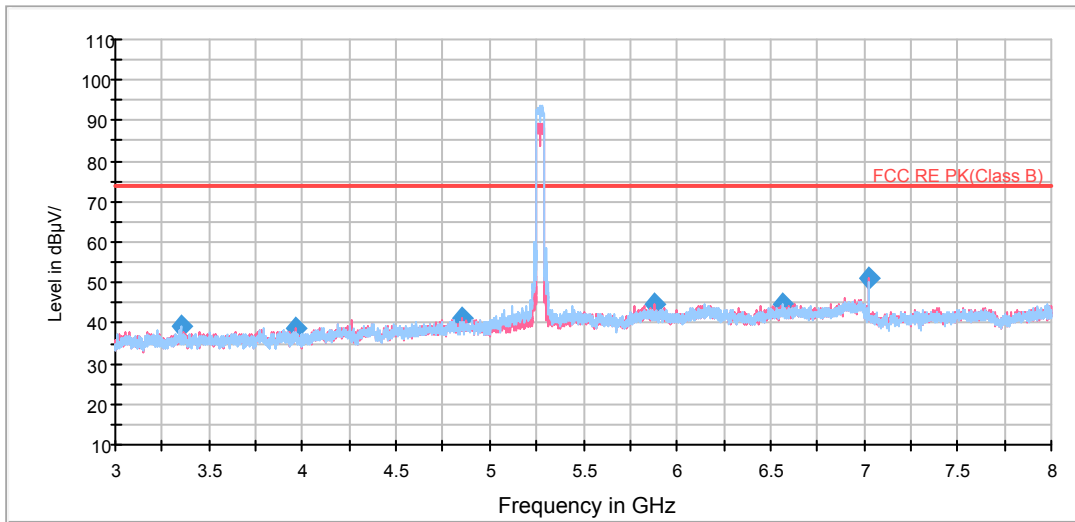

Note: The signal beyond the limit is carrier.
Radiates Emission from 3GHz to 8GHz

RE 3-18GHz PK+AV

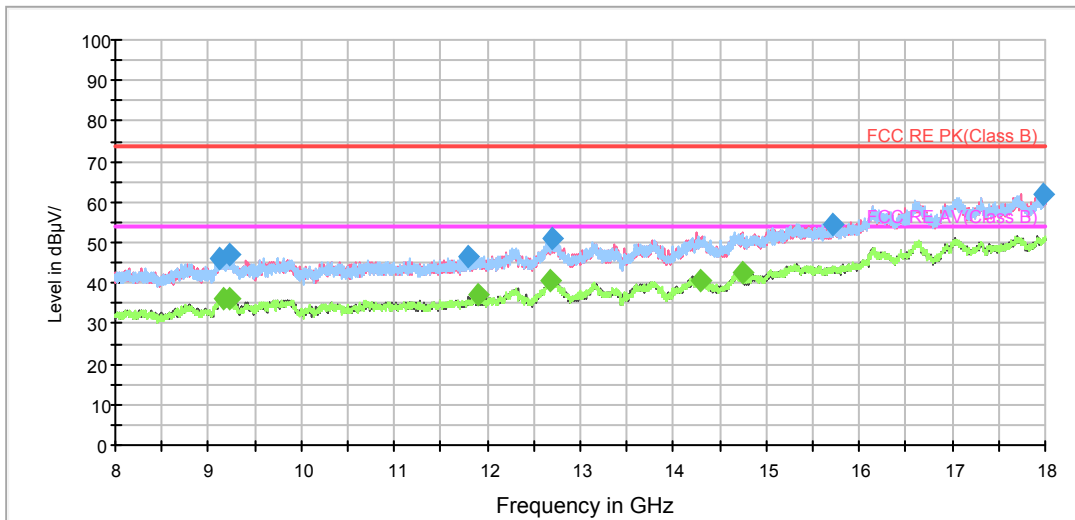

Radiates Emission from 8GHz to 18GHz

RE 18-26.5GHz PK+AV

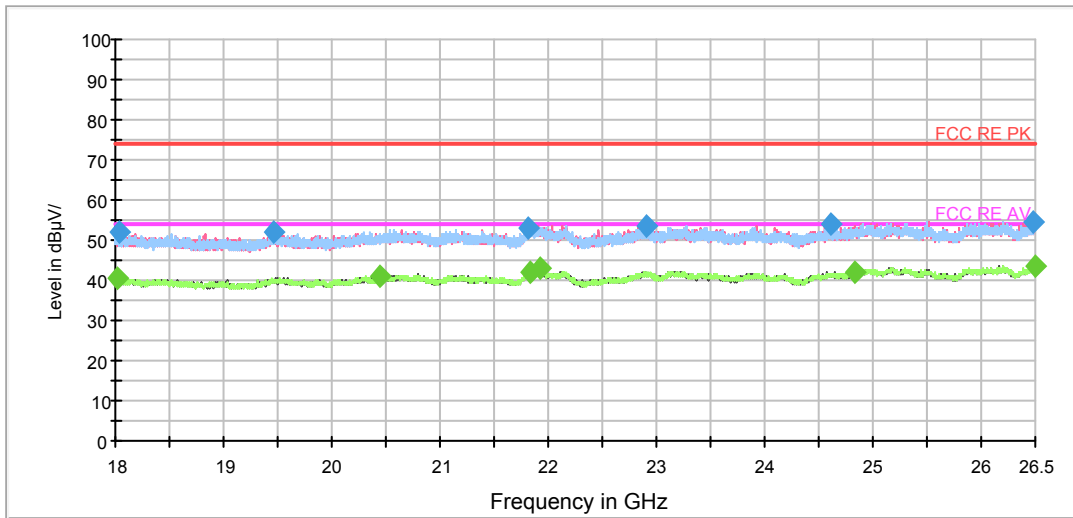

Radiates Emission from 18GHz to 26.5GHz

RE 26.5-40GHz PK+AV Class B

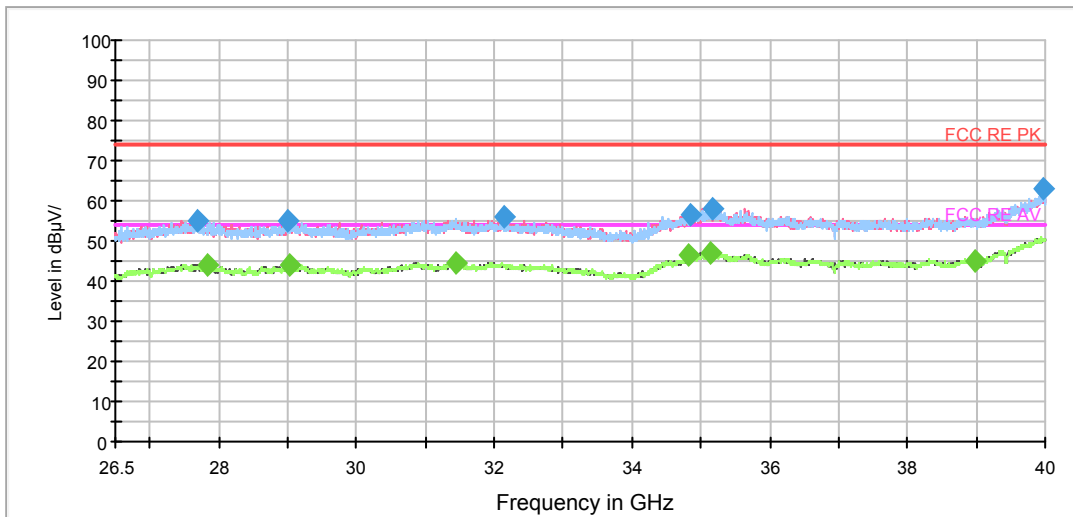

Radiates Emission from 26.5GHz to 40GHz

Frequency (MHz)	Peak (dBuV/m)	Height (cm)	Polarization	Azimuth (deg)	Reading value (dBuV/m)	Correct Factor (dB)	Margin (dB)	Limit (dBuV/m)
3348.125000	39.2	200.0	H	135.0	41.5	-2.3	34.8	74
3968.125000	38.8	200.0	V	219.0	39.7	-0.9	35.2	74
4850.625000	41.3	200.0	V	0.0	39.7	1.6	32.7	74
5878.750000	44.5	200.0	V	317.0	39.6	4.9	29.5	74
6561.250000	44.8	200.0	H	47.0	39.0	5.8	29.2	74
7026.875000	50.9	200.0	V	346.0	44.5	6.4	23.1	74

Remark: 1. Correction Factor = Antenna factor+ Insertion loss (cable loss + amplifier gain)



Frequency (MHz)	Average (dBuV/m)	Height (cm)	Polarization	Azimuth (deg)	Reading value (dBuV/m)	Correct Factor (dB)	Margin (dB)	Limit (dBuV/m)
3839.375000	25.9	200.0	V	333.0	27.6	-1.7	28.1	54
4336.250000	27.7	200.0	V	333.0	27.2	0.5	26.3	54
4903.750000	29.3	200.0	H	0.0	27.4	1.9	24.7	54
5506.250000	31.5	200.0	V	0.0	28.4	3.1	22.5	54
6173.125000	32.4	200.0	V	333.0	26.9	5.5	21.6	54
7026.875000	45.9	200.0	H	279.0	39.5	6.4	8.1	54

Remark: 1. Correction Factor = Antenna factor+ Insertion loss (cable loss + amplifier gain)