

FCC TEST REPORT for Part 15G**No. 180100286SHA-001**

Applicant : Huawei Technologies Co.,Ltd
Administration Building, Headquarters of
Huawei Technologies Co., Ltd., Bantian, Longgang
District, Shenzhen, China

Manufacturer : Huawei Technologies Co.,Ltd
Administration Building, Headquarters of
Huawei Technologies Co., Ltd., Bantian, Longgang
District, Shenzhen, China

Product Name : Solar Inverter

Type/Model : SUN2000-100KTL-USH0

TEST RESULT : PASS

SUMMARY

The equipment complies with the requirements SUN2000-100KTL-USH0 according to the following standard(s) or specification:

47CFR Part 15 (2017): Radio Frequency Devices (Subpart G)

ANSI C63.4 (2014): American National Standard for Methods of Measurement of Radio-Noise Emissions from Low-Voltage Electrical and Electronic Equipment in the Range of 9 kHz to 40 GHz

Date of issue: February 06, 2018

Prepared by:

Chris Chen (Project Engineer)

Reviewed by:

Daniel Zhao (Reviewer)

Description of Test Facility

Name: Intertek Testing Services Limited Shanghai

Address: Building 86, No. 1198 Qinzhou Rd., North, Shanghai 200233, P.R.China

FCC Accredited Lab Designation Number: CN1175

IC Assigned Code: 2042B-1

Name of contact: Jonny Jing

Tel: +86 21 61278271

Fax: +86 21 54262353

Content

SUMMARY	1
DESCRIPTION OF TEST FACILITY	2
1 GENERAL INFORMATION	4
1.1 Description of Equipment Under Test (EUT).....	4
1.2 Description of Client.....	5
1.3 Description of Test Facility	5
2 TEST SPECIFICATIONS	6
2.1 Standards or specification	6
2.2 Mode of operation during the test	6
2.3 Test software list	6
2.4 Test peripherals list	6
2.5 Instrument list	7
2.6 Test Summary	8
3 CONDUCTED EMISSION	9
3.1 Limits	9
3.1.1 Limits for conducted emission of class A device	9
3.1.2 Limits for conducted emission of class B device.....	9
3.2 Test setup	10
3.3 Test Setup and Test Procedure.....	11
3.4 Test Protocol	12
3.5 Measurement uncertainty.....	12
4 RADIATED EMISSION	13
4.1 Radiated emission limits	13
4.2 Test Environment.....	14
4.3 Description of the Test Sites	16
4.4 Test Setup and Test Procedure.....	22
4.5 Test Protocol	23
4.6 Measurement uncertainty.....	29

1 GENERAL INFORMATION

1.1 Description of Equipment Under Test (EUT)

Product Name	:	Solar Inverter
Type/Model	:	SUN2000-100KTL-USH0
Description of EUT	:	There is one model only.
Rating	:	Max input Voltage: 1500Vd.c. , Max input Current: 22A/22A/22A/22A/22A/22A, Nominal output Voltage: 704- 880Va.c. , Output rated Power: 100 kW; Max output Current: 72.9A
Modulation	:	OFDM
Number of carriers	:	512
Carrier spacing	:	24.414kHz
Channel bandwidth	:	200kHz
Notch capability/control	:	Without such function
Power settings/control	:	-5~7 (7 is the highest power and tested as the worst mode)
Duty factor of signal injection	:	50%
Category of EUT	:	Class B
Operation Frequency range for 15G	:	2.5MHz – 5.7MHz
Sample received date	:	January 11, 2018
Date of test	:	January 11, 2018 - January 24, 2018
Power line type	:	<input type="checkbox"/> Medium-voltage <input checked="" type="checkbox"/> low -voltage
FCC ID	:	QIS100KTLUSH0PLC

1.2 Description of Client

Applicant : Huawei Technologies Co.,Ltd
Administration Building, Headquarters of
Huawei Technologies Co., Ltd., Bantian, Longgang
District, Shenzhen, China

Name of contact : Zhang Xinghai

Tel : 8675528970299

Fax : 8675589650226

Email : zhangxinghai@huawei.com

Manufacturer : Huawei Technologies Co.,Ltd
Administration Building, Headquarters of
Huawei Technologies Co., Ltd., Bantian, Longgang
District, Shenzhen, China

1.3 Description of Test Facility

Name : Intertek Testing Service Shanghai

Address : Building 86, No. 1198 Qinzhou Road(North), Shanghai
200233, P.R. China

Telephone : 86 21 61278200

Telefax : 86 21 54262353

In-site location

Name : Huawei Technologies Co.,Ltd

Address : Manka Science and Technology Park, No 901 Tanglu
Road, Shanghai, P.R. China

2 TEST SPECIFICATIONS

2.1 Standards or specification

47CFR Part 15 (2017)
ANSI C63.4 (2014)
FCC-11-160A1

2.2 Mode of operation during the test

Within this test report, EUT was tested with modulation and tested under its rating voltage and frequency.

2.3 Test software list

Test Items	Software	Manufacturer	Version
/	/	/	/
/	/	/	/

2.4 Test peripherals list

Item No.	Name	Band and Model	Description
/	/	/	/
/	/	/	/

2.5 Instrument list

Selected	Instrument	Model	Manufactory	EC no.	Valid until date
<input checked="" type="checkbox"/>	EMI Test Receiver	ESPI3	R&S	101505	10/29/2018
<input checked="" type="checkbox"/>	Bilog Antenna	CBL 6112D	TESEQ	25221	5/20/2018
<input checked="" type="checkbox"/>	Loop Antenna	FMZB1516	Schwarzbeck	1516115	5/27/2018

2.6 Test Summary

This report applies to tested sample only. The test results have been compared directly with the limits, and the measurement uncertainty is recorded. This report shall not be reproduced in part without written approval of Intertek Testing Service Shanghai Limited.

TEST ITEM	FCC REFERANCE	RESULT	NOTE
Conducted emission	15.611(a), 15.107	NA	Not applied to Access BPL.
Radiated emission	15.611(b), 15.109	Pass	/

Notes: 1: NA =Not Applicable

2: This report is for the exclusive use of Intertek's Client and is provided pursuant to the agreement between Intertek and its Client. Intertek's responsibility and liability are limited to the terms and conditions of the agreement. Intertek assumes no liability to any party, other than to the Client in accordance with the agreement, for any loss, expense or damage occasioned by the use of this report. Only the Client is authorized to permit copying or distribution of this report and then only in its entirety. Any use of the Intertek name or one of its marks for the sale or advertisement of the tested material, product or service must first be approved in writing by Intertek. The observations and test results in this report are relevant only to the sample tested. This report by itself does not imply that the material, product, or service is or has ever been under an Intertek certification program.

3 Conducted emission

Test result: NA

3.1 Limits

3.1.1 Limits for conducted emission of class A device

Frequency range (MHz)	Limits dB(μV)	
	Quasi-peak	Average
0.15 ~ 0.5	79	66
0.5 ~ 30	73	60

Note: If the limit for the measurement with the average detector is met when using a receiver with a quasi-peak detector, the equipment under test shall be deemed to meet both limits and the measurement using the receiver with an average detector need not be carried out.

3.1.2 Limits for conducted emission of class B device

Frequency range (MHz)	Limits dB(μV)	
	Quasi-peak	Average
0.15 ~ 0.5	66 ~ 56 *	56 ~ 46 *
0.5 ~ 5	56	46
5 ~ 30	60	50

Note: 1. * Means the limit decreasing linearly with the logarithm of the frequency in the range 0.15MHz to 0.5MHz
2. If the limit for the measurement with the average detector is met when using a receiver with a quasi-peak detector, the equipment under test shall be deemed to meet both limits and the measurement using the receiver with an average detector need not be carried out.

3.2 Test setup

For table top equipment

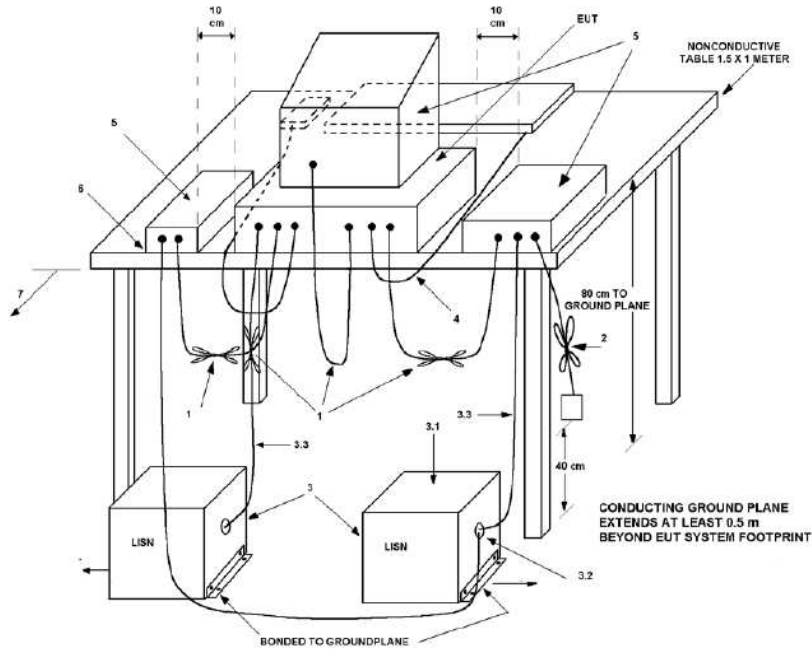

For floor standing equipment

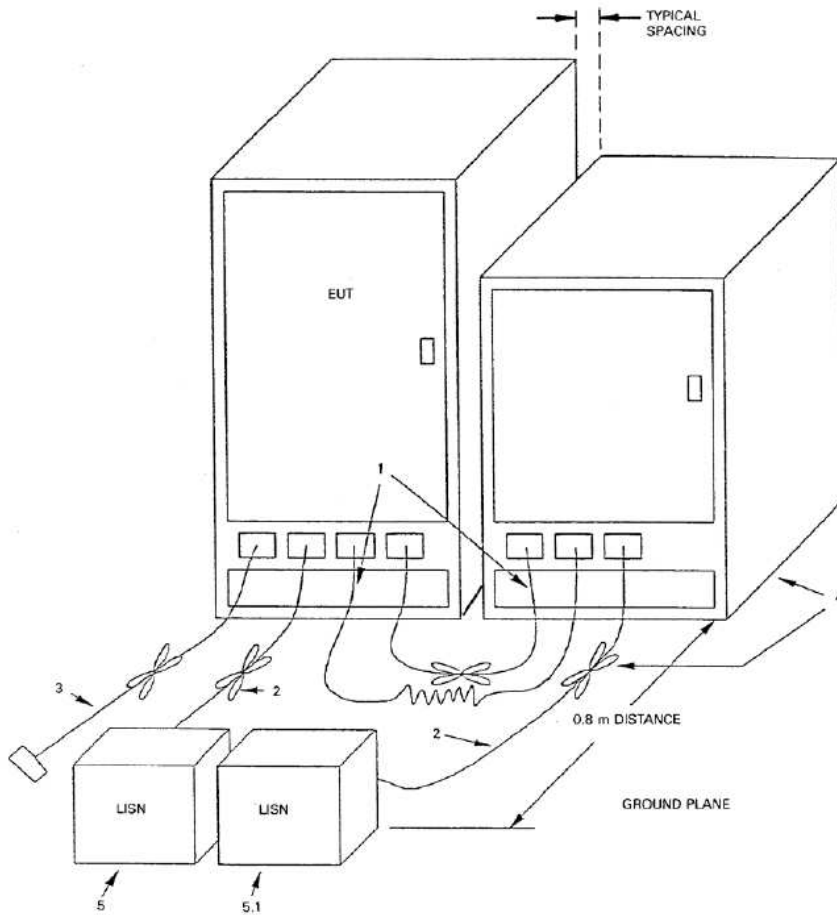

3.3 Test Setup and Test Procedure

Measurement was performed in shielded room, and instruments used were following clause 4 and clause 5 of ANSI 63.4.

Detailed test procedure was following clause 7.3 of ANSI 63.4.

EUT arrangement and operation conditions were according to clause 6 and clause 7 of ANSI 63.4.

Frequency range 150kHz – 30MHz was checked and EMI receiver measurement bandwidth was set to 9 kHz.

3.4 Test Protocol

Temperature : °C
Relative Humidity : %

Test Data:

Frequency (MHz)	Quasi-peak			Average		
	level dB(μV)	Limit dB(μV)	Margin (dB)	level dB(μV)	limit dB(μV)	Margin (dB)

Notes: All possible modes of operation were investigated. Only the worst case emissions was measured.

3.5 Measurement uncertainty

Measurement uncertainty: ± 3.19dB

The measurement uncertainty is given with a confidence of 95%, k=2.

4 Radiated emission

Test result: Pass

4.1 Radiated emission limits

Frequency (MHz)	Permitted limit in dB μ V/m (Quasi-peak) of Measurement Distance 30m
0.009 - 0.490	107.6-20lg (F _{kHz})
0.490 - 1.705	87.6-20lg (F _{kHz})
1.705 - 30.0	29.5
Note: for the measurement distance other than 30m, the limit is varied according to 40dB/10 decades. FCC REFERANCE 15.209	

Frequency (MHz)	Permitted limit in dB μ V/m (Quasi-peak) of Measurement Distance 3m
30 - 88	40.0
88 - 216	43.5
216 - 960	46.0
Above 960	54.0
Note: for the measurement distance other than 3m, the limit is varied according to 20dB/10 decades. FCC REFERANCE 15.109	

4.2 Test Environment

☒ Measurement Principles for Access BPL on Overhead Line Installations

(1) Measurements should normally be performed at the horizontal reference distance as specified in Sections 15.209 and 15.109 of the rules (i.e., 30 meters for frequencies below 30 MHz and 10 meters for frequencies 30-88MHz.) If necessary, due to ambient emissions, for frequencies below 30 MHz, measurements may be performed at a closer distance such as 10 meters (or 3 meters if necessary for safety or because measurements cannot practically be performed at 30 meters or 10 meters) from the overhead line. Distance corrections are to be made in accordance with paragraph (4), below.

(2) Testing shall be performed at distances of 0, 1/4, 1/2, 3/4 and 1 wavelength down the line from the BPL injection point on the power line. Wavelength spacing is based on the mid-band frequency used by the EUT. In addition, if the mid-band frequency exceeds the lowest frequency injected onto the power line by more than a factor of two, testing shall be extended in steps of 1/2 wavelength of the mid-band frequency until the distance equals or exceeds 1/2 wavelength of the lowest frequency injected. (For example, if the device injects frequencies from 3 to 27 MHz, the wavelength corresponding to the mid-band frequency of 15 MHz is 20 meters, and wavelength corresponding to the lowest injected frequency is 100 meters. Measurements are to be performed at 0, 5, 10, 15, and 20 meters down line—corresponding to zero to one wavelength at the mid-band frequency. Because the mid-band frequency exceeds the minimum frequency by more than a factor of two, additional measurements are required at 10-meter intervals until the distance down-line from the injection point equals or exceeds 1/2 of 100 meters. Thus, additional measurement points are required at 30, 40, and 50 meters down line from the injection point.)

(3) Testing shall be repeated for each Access BPL component (injector, extractor, repeater, booster, concentrator, etc.)

(4) The distance correction used to calculate the applicable extrapolated emission levels for the measurements that are closer than the specified reference distance in Section 15.209 of the rules shall be based on the slant-range distance, which is the diagonal distance from the center of the measurement antenna to the nearest point of the overhead power line carrying the BPL signals being measured, as defined in Section 15.3(hh) of the rules. Calculations of the slant-range distance and the applicable extrapolated emission levels are made according to Equations (1) and (2) in Section 6, below.

(5) For Access BPL devices operating below 30 MHz, if the site-specific alternative extrapolation method is selected, the extrapolation factor is determined by fitting a straight line to measurements of field strength in dB μ V/m vs. logarithmic distance in meters from the nearest conductor carrying BPL emissions. Site-specific determination of the extrapolation factor is not permitted for BPL devices that inject signals on the neutral/grounded line of a power system if a grounding conductor (typically located at each pole) is located within 30 meters of any of the measurement locations.

a. Measurements shall be made for at least four horizontal distances from the overhead line, at no less than 3 meters from the lateral plane and differing from each

other by at least 3 meters. If these measurements allow a straight line with a negative slope to be calculated or drawn with reasonable fit (the minimum regression coefficient of multiple correlation would be 0.9), the best straight line fit would be used to calculate field strength at the 30-meter standard measurement distance in the rules.

b. If the four measurements do not satisfy the regression coefficient requirement specified above, measurements at one or more additional distances shall be added until the regression coefficient is satisfied. If the regression coefficient is not satisfied, a site-specific extrapolation rate may not be used.

☒ Measurement Principles for Access BPL in Underground Line Installations

(1) Underground line installations are those in which the BPL device is mounted in, or attached to a padmounted transformer housing or a ground-mounted junction box and couples directly only to underground cables.

(2) Measurements should normally be performed at the horizontal reference distance as specified in Section 15.209 of the rules (i.e., 30 meters for frequencies below 30 MHz and 10 meters for frequencies 30-88MHz.) If necessary, due to ambient emissions, for frequencies below 30 MHz, measurements may be performed at a closer distance such as 3 meters or 10 meters from the inground transformer. Distance corrections are to be made in accordance with Section 15.31(f) in the rules.

(3) Measurements shall be made at positions around the perimeter of the in-ground power transformer where the maximum emissions occur. ANSI C63.4, section 8.1, specifies a minimum of 16 radial angles surrounding the EUT (in-ground transformer that contains the BPL device(s)). If directional radiation patterns are suspected, additional azimuth angles shall be examined.

Test setup is showed as below:

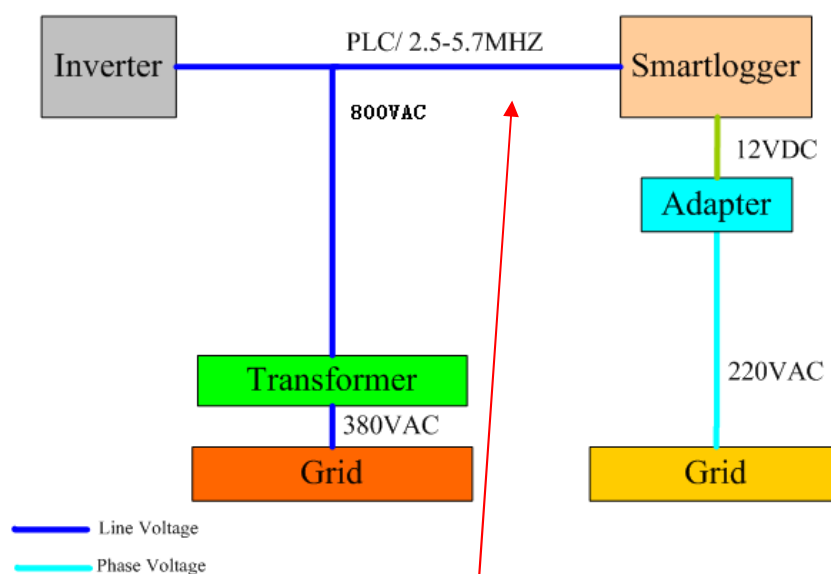

Overhead power line / Underground power line

4.3 Description of the Test Sites

☒ Overhead Line Installation Locations:

The device injects frequencies at 2.5MHz-5.7MHz;

The wavelength of mid-band frequency is 73.2m;

The wavelength corresponding to the lowest injected frequency is 120m and no extended test should be conducted.

Location 1: See below



Test Point	Test Distance down the line from the BPL injection point (m)
0	0
$1/4 * \lambda$	18.3
$1/2 * \lambda$	36.6
$3/4 * \lambda$	54.9
λ	73.2

Location 2: See below



Test Point	Test Distance down the line from the BPL injection point (m)
0	0
$1/4 * \lambda$	18.3
$1/2 * \lambda$	36.6
$3/4 * \lambda$	54.9
λ	73.2

Location 3: See below



Test Point	Test Distance down the line from the BPL injection point (m)
0	0
$1/4 * \lambda$	18.3
$1/2 * \lambda$	36.6
$3/4 * \lambda$	54.9
λ	73.2

Underground Line Installation Locations:

Measurements shall be made at positions of minimum of 16 radial angles surrounding the EUT, namely 0, 22.5°, 45°...337.5°.

Location 1: See below

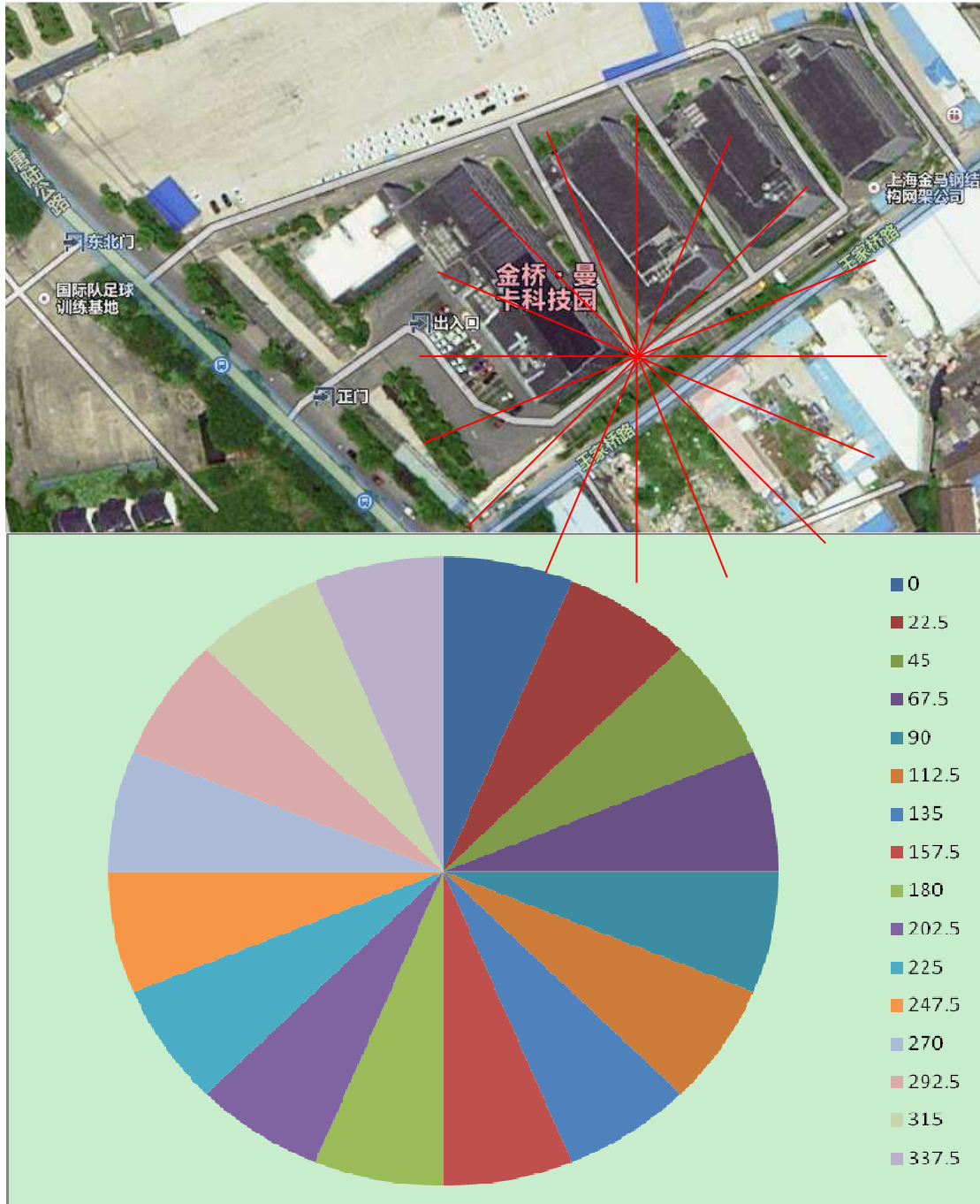

Location 2: See below

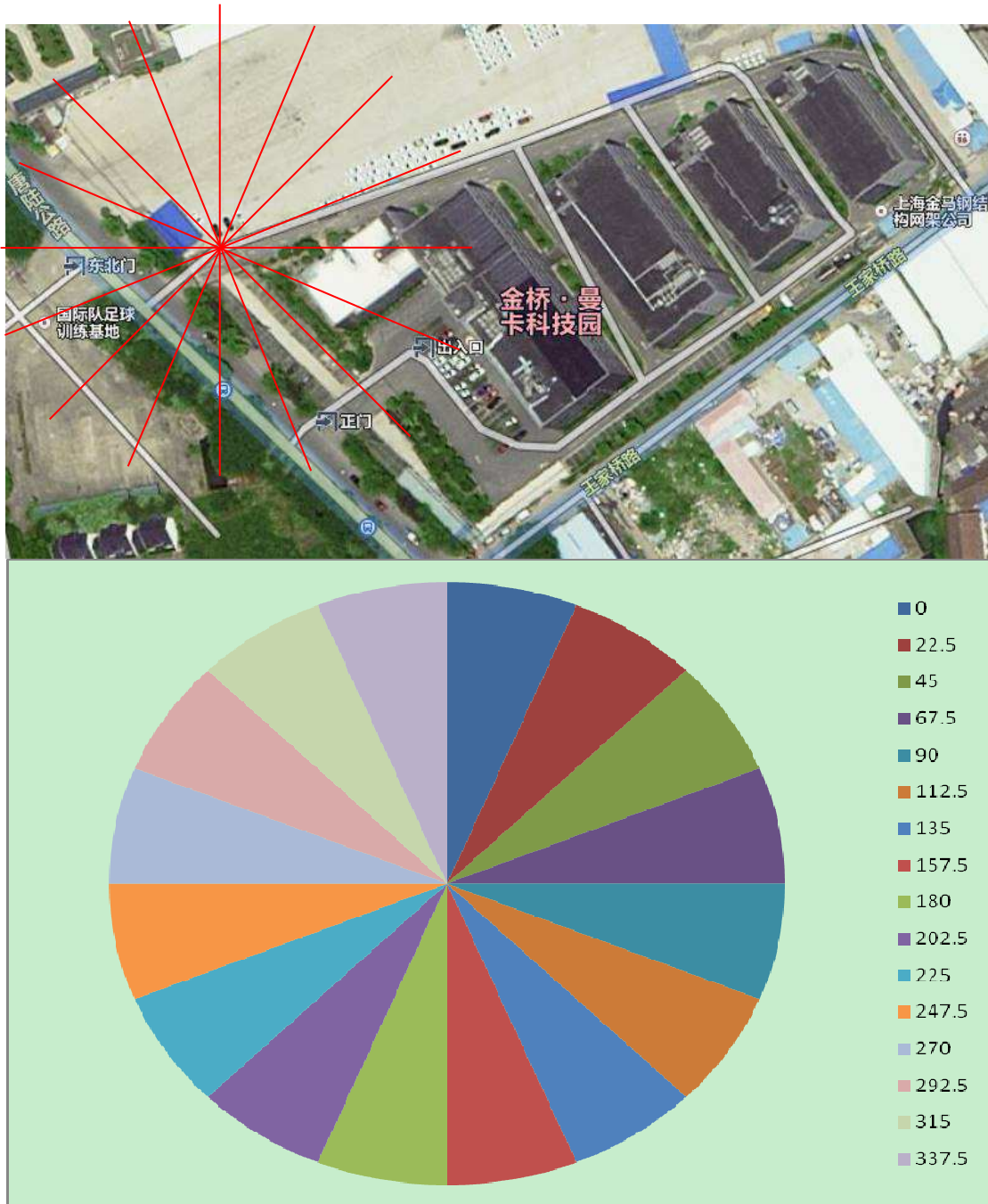

Location 3: See below

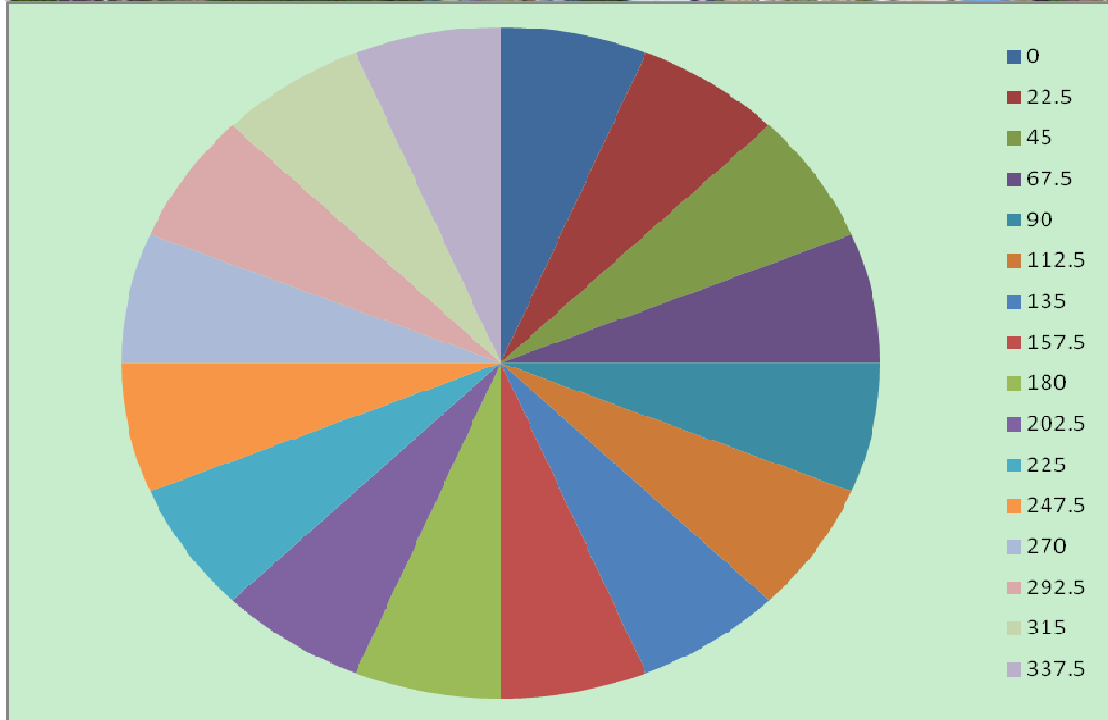
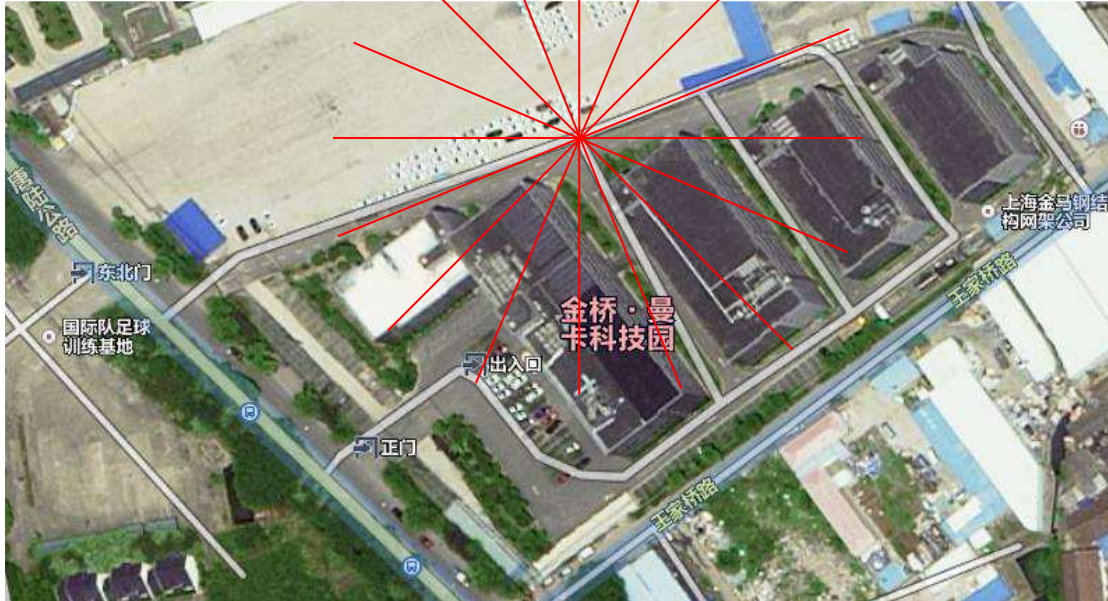

4.4 Test Setup and Test Procedure

The measurement was performed in site.

The horizontal distance between EUT and receiving antenna is **3** meter for both overhead & underground installation.

The required measurement frequency range was checked.

The radiated emission was measured using the R&S Test Receiver / Spectrum Analyzer with the resolutions bandwidth set as:

RBW =9kHz @ receiver mode (9kHz~30MHz)

RBW = 120kHz @ receiver mode (30MHz~1GHz)

RBW / VBW = 1MHz / 3MHz @ spectrum mode (>1GHz for PK) if applied;

RBW / VBW = 1MHz / 10Hz @ spectrum mode (>1GHz for AV) if applied;

Slant factor for lower than 30MHz @ overhead installation:

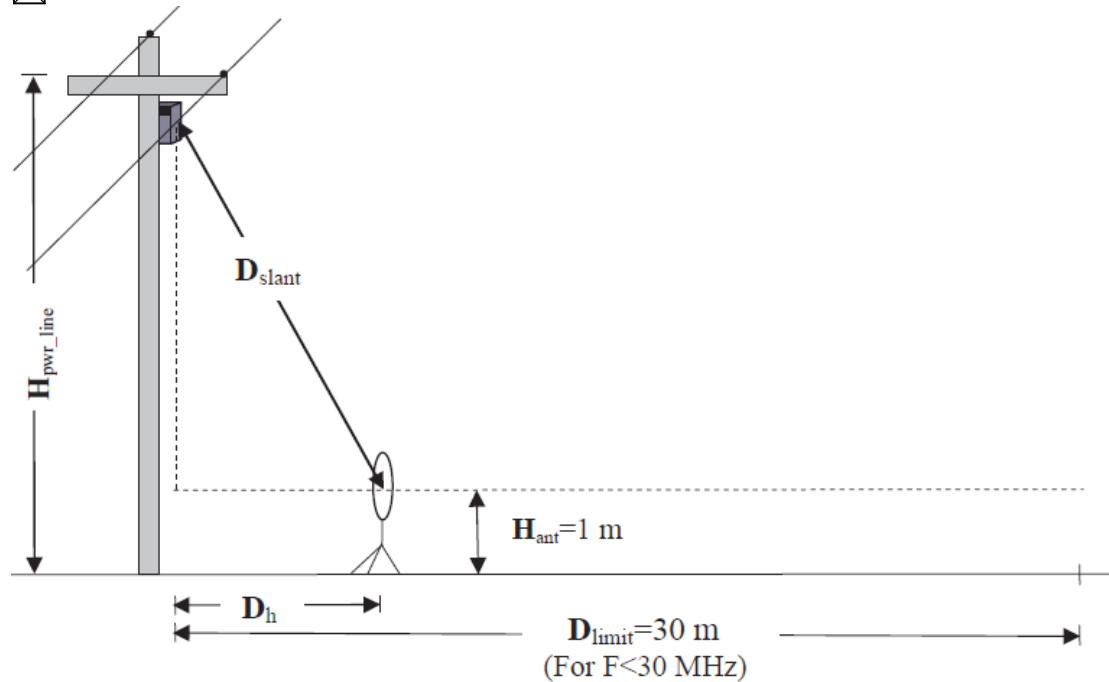

Here $H_{ant} = 1\text{ m}$, $H_{power_line} = 2\text{ m}$, $D_h = 3\text{ m}$;

Therefore $D_{slant} = (3^2 + (2-1)^2)^{1/2} = 3.2\text{ m}$;

Slant factor = $40\lg(30 / 3.2) = 38.9\text{ dB}$

Measurement distance factor for lower than 30MHz @ underground installation:

Distance factor = $40\lg(30 / 3) = 40\text{ dB}$

Antenna height factor for higher than 30MHz @ overhead and underground installation (the antenna height is fixed at 1m but not varied from 1m to 4 m): **Antenna height factor = -5dB**

4.5 Test Protocol

<i>Overhead location 1</i>									
A	B	C	D	E	F	G	H	I	J
Test Point (m)	Ant. Pol.	Freq. (MHz)	Reading (dBuV/m)	Ant. Factor (dB)	Cable loss (dB)	Slant factor / Ant height Factor (dB)	Net (dBuV/m)	Limit (dBuV/m)	Margin (dBuV/m)
0	Y	1.61	28.45	19.20	0.05	38.9	8.80	23.46	14.66
0	V	61.48	15.72	11.60	0.37	-5	32.69	40.00	7.31
0	H	127.18	22.38	9.07	0.55	-5	37.00	43.50	6.50
0	X	0.46	46.77	18.90	0.03	38.9	26.80	54.31	27.51
18.3	X	13.94	26.95	19.29	0.16	38.9	7.50	29.50	22.00
18.3	Y	2.61	29.14	19.20	0.06	38.9	9.50	29.50	20.00
18.3	Y	0.23	50.18	19.00	0.02	38.9	30.30	60.22	29.92
18.3	X	5.89	14.99	19.20	0.11	38.9	-4.60	29.50	34.10
18.3	H	425.00	15.56	16.65	0.99	-5	38.20	46.00	7.80
18.3	Y	2.65	30.64	19.20	0.06	38.9	11.00	29.50	18.50
18.3	V	345.96	20.04	14.62	0.94	-5	40.60	46.00	5.40
18.3	X	15.64	38.09	19.14	0.18	38.9	18.50	29.50	11.00
36.6	X	7.53	30.68	19.20	0.12	38.9	11.10	29.50	18.40
36.6	X	3.15	35.93	19.20	0.07	38.9	16.30	29.50	13.20
36.6	Y	0.37	52.77	18.90	0.03	38.9	32.80	56.24	23.44
36.6	X	4.27	18.01	19.20	0.09	38.9	-1.60	29.50	31.10
36.6	V	655.96	16.16	19.95	1.22	-5	42.33	46.00	3.67
36.6	Y	3.36	25.53	19.20	1.17	38.9	7.00	29.50	22.50
36.6	X	0.59	43.24	18.93	0.03	38.9	23.30	32.18	8.88
36.6	Y	4.28	23.31	19.20	0.09	38.9	3.70	29.50	25.80
36.6	X	22.05	10.28	19.81	0.22	38.9	-8.60	29.50	38.10
36.6	H	154.22	13.52	8.37	0.61	-5	27.50	43.50	16.00
36.6	H	154.82	22.89	8.37	0.61	-5	36.87	43.50	6.63
54.9	Y	6.62	41.79	19.20	0.11	38.9	22.20	29.50	7.30
54.9	Y	3.90	24.72	19.20	0.08	38.9	5.10	29.50	24.40
54.9	Y	4.55	22.41	19.20	0.09	38.9	2.80	29.50	26.70
54.9	X	3.30	25.43	19.20	0.07	38.9	5.80	29.50	23.70
54.9	Y	14.00	26.94	19.30	0.16	38.9	7.50	29.50	22.00
54.9	X	4.45	44.71	19.20	0.09	38.9	25.10	29.50	4.40
54.9	V	231.24	11.34	11.74	0.73	-5	28.80	46.00	17.20
54.9	Y	3.37	40.52	19.20	0.08	38.9	20.90	29.50	8.60
73.2	Y	9.74	33.27	19.20	0.13	38.9	13.70	29.50	15.80
73.2	X	4.78	27.40	19.20	0.10	38.9	7.80	29.50	21.70
73.2	Y	15.91	29.01	19.11	0.18	38.9	9.40	29.50	20.10
73.2	Y	3.42	38.02	19.20	0.08	38.9	18.40	29.50	11.10
73.2	Y	23.32	19.20	19.93	0.22	38.9	0.45	29.50	29.05

Note 1: H = D + E + F - G; J = I - H

Note 2: the QP detector is applied based on that the pulse-repetition frequency of assessed signal is higher than 20 Hz.

<i>Overhead location 2</i>									
A	B	C	D	E	F	G	H	I	J
Test Point (m)	Ant. Pol.	Freq. (MHz)	Reading (dBuV/m)	Ant. Factor (dB)	Cable loss (dB)	Slant factor / Ant height Factor (dB)	Net (dBuV/m)	Limit (dBuV/m)	Margin (dBuV/m)
0	Y	3.02	37.60	19.20	0.07	38.9	17.97	29.50	11.53
0	V	160.68	23.35	8.43	0.61	-5	37.40	43.50	6.10
0	X	5.89	26.91	19.20	0.11	38.9	7.32	29.50	22.18
0	V	88.30	19.13	9.32	0.45	-5	33.90	43.50	9.60
0	H	221.36	16.75	11.44	0.71	-5	33.90	46.00	12.10
0	Y	0.06	46.02	19.03	0.01	38.9	26.16	72.04	45.88
18.3	H	88.74	18.84	9.40	0.45	-5	33.70	43.50	9.80
18.3	Y	2.22	42.18	19.20	0.06	38.9	22.54	29.50	6.96
18.3	H	182.58	20.97	9.58	0.65	-5	36.20	43.50	7.30
18.3	X	4.25	32.74	18.90	0.03	38.9	12.77	29.50	16.73
18.3	V	851.24	11.81	22.22	1.37	-5	40.40	46.00	5.60
18.3	V	206.36	17.23	10.99	0.68	-5	33.90	43.50	9.60
36.6	V	452.58	9.84	17.04	1.02	-5	32.90	46.00	13.10
36.6	Y	5.15	28.76	19.20	0.10	38.9	9.16	29.50	20.34
36.6	V	213.16	22.81	11.19	0.69	-5	39.70	43.50	3.80
36.6	V	124.86	20.95	9.21	0.54	-5	35.70	43.50	7.80
36.6	Y	1.46	34.05	19.20	0.05	38.9	14.40	24.32	9.92
36.6	X	9.81	31.97	19.20	0.13	38.9	12.40	29.50	17.10
36.6	V	612.94	9.84	19.60	1.16	-5	35.60	46.00	10.40
54.9	H	794.28	11.56	21.43	1.31	-5	39.30	46.00	6.70
54.9	Y	0.38	62.37	18.90	0.03	38.9	42.40	56.05	13.65
54.9	Y	1.20	41.16	19.20	0.04	38.9	21.50	26.00	4.50
54.9	V	338.62	11.87	14.40	0.93	-5	32.20	46.00	13.80
54.9	X	18.22	33.48	19.31	0.20	38.9	14.09	29.50	15.41
54.9	X	0.47	56.82	18.90	0.03	38.9	36.85	54.23	17.38
54.9	H	645.96	13.93	19.87	1.20	-5	40.00	46.00	6.00
54.9	V	444.20	11.57	16.92	1.01	-5	34.50	46.00	11.50
54.9	Y	0.87	41.69	19.07	0.04	38.9	21.90	28.81	6.91
73.2	V	269.30	17.64	12.65	0.81	-5	36.10	46.00	9.90
73.2	X	1.06	35.06	19.20	0.04	38.9	15.40	27.08	11.68
73.2	H	144.52	16.89	8.32	0.59	-5	30.80	43.50	12.70
73.2	X	0.66	46.11	18.95	0.03	38.9	26.20	31.24	5.04

Note 1: H = D + E + F - G; J = I-H

Note 2: the QP detector is applied based on that the pulse-repetition frequency of assessed signal is higher than 20 Hz.

Overhead location 3									
A	B	C	D	E	F	G	H	I	J
Test Point (m)	Ant. Pol.	Freq. (MHz)	Reading (dBuV/m)	Ant. Factor (dB)	Cable loss (dB)	Slant factor / Ant height Factor (dB)	Net (dBuV/m)	Limit (dBuV/m)	Margin (dBuV/m)
0	Y	3.97	22.32	19.20	0.08	38.9	2.70	29.50	26.80
0	X	0.04	37.83	18.96	0.01	38.9	17.90	75.20	57.30
0	V	215.64	21.43	11.27	0.70	-5	38.40	43.50	5.10
0	H	459.90	8.03	17.14	1.03	-5	31.20	46.00	14.80
0	Y	1.19	34.86	19.20	0.04	38.9	15.20	26.12	10.92
0	V	56.28	13.71	12.64	0.35	-5	31.70	40.00	8.30
0	Y	1.41	39.35	19.20	0.05	38.9	19.70	24.63	4.93
0	V	800.35	14.18	21.50	1.31	-5	42.00	46.00	4.00
18.3	X	0.71	47.70	18.97	0.03	38.9	27.80	30.57	2.77
18.3	H	747.66	8.43	20.87	1.30	-5	35.60	46.00	10.40
18.3	V	704.10	10.69	20.35	1.26	-5	37.30	46.00	8.70
18.3	V	414.48	17.63	16.50	0.97	-5	40.10	46.00	5.90
18.3	X	2.20	25.45	19.20	0.06	38.9	5.81	29.50	23.69
18.3	V	438.32	10.76	16.84	1.00	-5	33.60	46.00	12.40
18.3	X	1.23	35.26	19.20	0.04	38.9	15.60	25.77	10.17
18.3	H	157.80	23.10	8.39	0.61	-5	37.10	43.50	6.40
36.6	X	2.73	38.73	19.20	0.07	38.9	19.10	29.50	10.40
36.6	X	0.57	50.34	18.92	0.03	38.9	30.40	32.42	2.02
36.6	Y	26.75	23.97	20.45	0.24	38.9	5.76	29.50	23.74
36.6	V	692.80	13.82	20.24	1.13	-5	40.20	46.00	5.80
36.6	X	1.80	34.25	19.20	0.05	38.9	14.60	29.50	14.90
36.6	X	1.30	36.56	19.20	0.04	38.9	16.90	25.35	8.45
36.6	H	354.14	12.48	14.88	0.94	-5	33.30	46.00	12.70
54.9	H	407.44	11.74	16.40	0.96	-5	34.10	46.00	11.90
54.9	Y	0.22	49.35	19.02	0.02	38.9	29.49	40.83	11.34
54.9	X	4.59	23.02	19.20	0.09	38.9	3.41	29.50	26.09
54.9	V	134.90	21.03	8.61	0.57	-5	35.20	43.50	8.30
54.9	X	5.91	25.80	19.20	0.11	38.9	6.21	29.50	23.29
73.2	H	794.52	13.96	21.43	1.31	-5	41.70	46.00	4.30
73.2	H	861.54	8.96	22.36	1.38	-5	37.70	46.00	8.30
73.2	X	0.48	62.97	18.90	0.03	38.9	43.00	54.01	11.01
73.2	Y	11.47	18.11	18.98	0.14	38.9	-1.67	29.50	31.17
73.2	V	242.28	14.29	12.07	0.75	-5	32.10	46.00	13.90

Note 1: $H = D + E + F - G$; $J = I - H$

Note 2: the QP detector is applied based on that the pulse-repetition frequency of assessed signal is higher than 20 Hz.

<i>Underground location 1</i>									
A	B	C	D	E	F	G	H	I	J
Test Angle (degree)	Ant. Pol.	Freq. (MHz)	Reading (dBuV/m)	Ant. Factor (dB)	Cable loss (dB)	Ant height / Distance Factor (dB)	Net (dBuV/m)	Limit (dBuV/m)	Margin (dBuV/m)
0	Y	0.02	53.39	19.01	0.00	40	32.40	80.37	47.97
0	Y	3.41	32.86	19.20	0.08	40	12.14	29.50	17.36
0	Y	1.77	40.30	19.20	0.05	40	19.55	29.50	9.95
0	V	43.7	17.50	13.90	1.39	-5	37.79	40.00	2.21
0	V	561	17.70	18.80	1.10	-5	42.60	46.00	3.40
22.5	V	72.26	19.47	9.40	0.40	-5	34.27	40.00	5.73
22.5	X	0.14	73.81	19.15	0.01	40	52.97	64.99	12.02
22.5	X	5.05	37.81	19.20	0.10	40	17.11	29.50	12.39
45	V	52.3	19.15	13.44	0.34	-5	37.93	40.00	2.07
45	X	0.59	49.94	18.93	0.03	40	28.90	32.18	3.28
45	H	64.94	19.93	10.91	0.38	-5	36.22	40.00	3.78
67.5	Y	6.19	36.18	19.20	0.11	40	15.49	29.50	14.01
67.5	H	45.78	17.89	13.90	0.31	-5	37.10	40.00	2.90
67.5	Y	7.28	34.81	19.20	0.11	40	14.12	29.50	15.38
90	X	12.39	29.01	18.98	0.15	40	8.14	29.50	21.36
90	V	50.2	16.43	13.86	0.33	-5	35.62	40.00	4.38
112.5	V	41.33	17.29	13.90	0.30	-5	36.49	40.00	3.51
135	V	808.2	15.11	21.61	1.32	-5	43.04	46.00	2.96
157.5	Y	9.93	47.70	19.20	0.13	40	27.03	29.50	2.47
157.5	X	17.52	29.90	19.25	0.19	40	9.34	29.50	20.16
180	X	1.67	41.60	19.20	0.05	40	20.85	23.15	2.30
180	V	830.58	12.89	21.93	1.35	-5	41.16	46.00	4.84
202.5	V	43.85	17.93	13.90	0.31	-5	37.14	40.00	2.86
225	H	87.48	23.10	9.16	0.45	-5	37.71	40.00	2.29
247.5	X	2.13	40.90	19.20	0.06	40	20.16	29.50	9.34
247.5	Y	27.45	19.43	20.59	0.24	40	0.26	29.50	29.24
270	Y	0.786	47.78	19.00	0.04	40	26.81	29.69	2.88
315	Y	0.85	42.15	19.05	0.04	40	21.24	29.01	7.77
315	Y	0.63	47.77	18.94	0.03	40	26.75	31.61	4.86
337.5	H	654.04	16.44	19.93	1.21	-5	42.59	46.00	3.41
337.5	X	0.51	52.00	18.90	0.03	40	30.93	33.45	2.52
337.5	V	800.32	14.12	21.50	1.31	-5	41.93	46.00	4.07

Note 1: $H = D + E + F - G$; $J = I - H$

Note 2: the QP detector is applied based on that the pulse-repetition frequency of assessed signal is higher than 20 Hz.

<i>Underground location 2</i>									
A	B	C	D	E	F	G	H	I	J
Test Angle (degree)	Ant. Pol.	Freq. (MHz)	Reading (dBuV/m)	Ant. Factor (dB)	Cable loss (dB)	Ant height / Distance Factor (dB)	Net (dBuV/m)	Limit (dBuV/m)	Margin (dBuV/m)
0	X	0.35	61.90	18.90	0.02	40	40.82	56.72	15.90
0	V	123.28	19.46	9.30	0.54	-5	34.30	43.50	9.20
0	Y	1.21	42.86	19.20	0.04	40	22.10	25.89	3.79
22.5	X	1.97	46.85	19.20	0.05	40	26.10	29.50	3.40
67.5	Y	0.59	49.14	18.93	0.03	40	28.10	32.07	3.97
90	H	84.06	18.67	8.49	0.44	-5	32.60	40.00	7.40
112.5	V	138.60	22.54	8.38	0.57	-5	36.50	43.50	7.00
135	X	1.15	40.26	19.20	0.04	40	19.50	26.33	6.83
135	H	72.56	21.36	9.34	0.40	-5	36.10	40.00	3.90
135	V	564.64	17.33	18.86	1.10	-5	42.30	46.00	3.70
157.5	X	3.02	46.83	19.20	0.07	40	26.10	29.50	3.40
157.5	Y	1.87	43.65	19.20	0.05	40	22.90	29.50	6.60
157.5	V	652.20	15.97	19.92	1.21	-5	42.10	46.00	3.90
157.5	H	839.28	13.79	22.05	1.36	-5	42.20	46.00	3.80
180	Y	0.50	51.67	18.90	0.03	40	30.60	33.59	2.99
180	X	3.70	43.02	19.20	0.08	40	22.30	29.50	7.20
180	V	85.52	20.98	8.78	0.44	-5	35.20	40.00	4.80
202.5	Y	3.57	49.02	19.20	0.08	40	28.30	29.50	1.20
202.5	H	81.02	20.47	7.90	0.43	-5	33.80	40.00	6.20
202.5	X	0.60	48.83	18.93	0.03	40	27.80	32.01	4.21
202.5	Y	3.11	48.48	19.20	0.07	40	27.75	29.50	1.75
202.5	X	3.04	47.36	19.20	0.07	40	26.63	29.50	2.87
225	X	2.69	48.13	19.20	0.07	40	27.40	29.50	2.10
225	V	210.54	23.21	11.12	1.27	-5	40.60	43.50	2.90
225	H	805.08	14.51	21.57	1.32	-5	42.40	46.00	3.60
247.5	V	132.08	25.96	8.78	0.56	-5	40.30	43.50	3.20
247.5	V	652.24	16.27	19.92	1.21	-5	42.40	46.00	3.60
270	H	549.38	18.92	18.59	1.09	-5	43.60	46.00	2.40
270	V	831.40	13.91	21.94	1.35	-5	42.20	46.00	3.80
270	V	348.96	21.94	14.72	0.94	-5	42.60	46.00	3.40
292.5	Y	2.22	42.18	19.20	0.06	40	21.44	29.50	8.06
292.5	V	84.74	22.73	8.62	0.44	-5	36.80	40.00	3.20
292.5	Y	2.33	46.24	19.20	0.06	40	25.50	29.50	4.00
315	H	82.30	20.42	8.15	0.43	-5	34.00	40.00	6.00
315	H	210.48	22.80	11.11	0.69	-5	39.60	43.50	3.90
337.5	V	569.56	14.44	18.95	1.11	-5	39.50	46.00	6.50

Note 1: H = D + E + F - G; J = I - H

Note 2: the QP detector is applied based on that the pulse-repetition frequency of assessed signal is higher than 20 Hz.

<i>Underground location 3</i>									
A	B	C	D	E	F	G	H	I	J
Test Angle (degree)	Ant. Pol.	Freq. (MHz)	Reading (dBuV/m)	Ant. Factor (dB)	Cable loss (dB)	Ant height / Distance Factor (dB)	Net (dBuV/m)	Limit (dBuV/m)	Margin (dBuV/m)
0	X	0.21	50.74	19.04	0.02	40	29.80	61.16	31.36
0	Y	1.54	40.85	19.20	0.05	40	20.10	23.86	3.76
0	V	75.66	20.73	8.65	0.41	-5	34.80	40.00	5.20
22.5	H	49.20	15.77	13.90	0.33	-5	35.00	40.00	5.00
22.5	X	0.38	58.28	18.90	0.38	40	37.56	55.96	18.40
67.5	H	86.10	23.00	8.89	0.45	-5	37.34	40.00	2.66
90	X	0.75	43.50	18.98	0.04	40	22.52	30.05	7.53
90	Y	1.63	26.43	19.20	0.05	40	5.68	23.36	17.68
112.5	V	207.62	23.99	11.03	0.68	-5	40.70	43.50	2.80
135	V	85.08	22.97	8.69	0.44	-5	37.10	40.00	2.90
135	V	89.46	24.60	9.54	0.46	-5	39.60	43.50	3.90
157.5	H	76.68	22.35	8.43	0.42	-5	36.20	40.00	3.80
180	X	3.97	22.32	19.20	0.08	40	1.60	29.50	27.90
180	V	149.42	25.55	8.35	0.60	-5	39.50	43.50	4.00
180	Y	4.61	22.00	19.20	0.09	40	1.29	29.50	28.21
202.5	V	752.44	15.37	20.93	1.30	-5	42.60	46.00	3.40
202.5	Y	3.20	27.71	19.20	1.41	40	8.32	17.50	9.18
225	H	72.86	22.33	9.27	0.40	-5	37.00	40.00	3.00
225	X	6.17	25.98	19.20	0.11	40	5.29	29.50	24.21
225	X	5.65	30.90	19.20	0.10	40	10.20	12.56	2.36
247.5	X	8.83	15.23	19.20	0.12	40	-5.45	29.50	34.95
247.5	Y	15.71	17.73	19.13	0.18	40	-2.96	29.50	32.46
247.5	V	557.51	16.37	18.74	1.10	-5	41.20	46.00	4.80
247.5	H	87.32	20.02	9.13	0.45	-5	34.60	40.00	5.40
270	V	559.46	16.33	18.77	1.10	-5	41.20	46.00	4.80
292.5	H	136.86	24.04	8.49	0.57	-5	38.10	43.50	5.40
315	V	138.44	26.63	8.39	0.57	-5	40.60	43.50	2.90
315	V	86.72	22.69	9.01	0.45	-5	37.15	40.00	2.85
337.5	V	664.10	12.86	20.01	1.22	-5	39.10	46.00	6.90
337.5	Y	23.49	12.93	19.95	0.22	40	-6.90	29.50	36.40

Note 1: H = D + E + F - G; J = I - H

Note 2: the QP detector is applied based on that the pulse-repetition frequency of assessed signal is higher than 20 Hz.

4.6 Measurement uncertainty

Measurement uncertainty of radiated emission (30MHz-1000MHz) is: $\pm 4.90\text{dB}$
Measurement uncertainty of radiated emission (1000MHz-6000MHz) is: $\pm 5.02\text{dB}$
The measurement uncertainty is given with a confidence of 95%, $k=2$.

Representative emissions spectrum Plot

