

FCC Radio Test Report

FCC ID: QIS-TE10

This report concerns (check one): Original Grant Class I Change Class II Change

Project No. : 1608C052
Equipment : Videoconferencing Endpoint
Model Name : HUAWEI TE10
Applicant : Huawei Technologies Co., Ltd.
Address : Administration Building, Headquarters of Huawei Technologies Co., Ltd., Bantian, Longgang District Shenzhen, 518129, P.R.C

Date of Receipt : Aug. 04, 2016
Date of Test : Aug. 04, 2016 ~ Aug. 30, 2016
Issued Date : Aug. 31, 2016
Tested by : BTL Inc.

Testing Engineer :

Shawn Xiao
(Shawn Xiao)

Technical Manager :

David Mao
(David Mao)

Authorized Signatory :

Steven Lu
(Steven Lu)

B T L I N C .

No.3, Jinshagang 1st Road, Shixia, Dalang Town, Dongguan,
Guangdong, China.

TEL: +86-769-8318-3000 FAX: +86-769-8319-6000

Declaration

BTL represents to the client that testing is done in accordance with standard procedures as applicable and that test instruments used has been calibrated with standards traceable to international standard(s) and/or national standard(s).

BTL's reports apply only to the specific samples tested under conditions. It is manufacture's responsibility to ensure that additional production units of this model are manufactured with the identical electrical and mechanical components. **BTL** shall have no liability for any declarations, inferences or generalizations drawn by the client or others from **BTL** issued reports.

BTL's report must not be used by the client to claim product certification, approval, or endorsement by NVLAP, NIST, or any agency of the Federal Government.

This report is the confidential property of the client. As a mutual protection to the clients, the public and **BTL-self**, extracts from the test report shall not be reproduced except in full with **BTL's** authorized written approval.

BTL's laboratory quality assurance procedures are in compliance with the **ISO Guide 17025** requirements, and accredited by the conformity assessment authorities listed in this test report.

Limitation

For the use of the authority's logo is limited unless the Test Standard(s)/Scope(s)/Item(s) mentioned in this test report is (are) included in the conformity assessment authorities acceptance respective.

Table of Contents	Page
1 . CERTIFICATION	6
2 . SUMMARY OF TEST RESULTS	7
2.1 TEST FACILITY	8
2.2 MEASUREMENT UNCERTAINTY	8
3 . GENERAL INFORMATION	9
3.1 GENERAL DESCRIPTION OF EUT	9
3.2 DESCRIPTION OF TEST MODES	11
3.3 TABLE OF PARAMETERS OF TEST SOFTWARE SETTING	13
3.4 BLOCK DIAGRAM SHOWING THE CONFIGURATION OF SYSTEM TESTED	14
3.5 DESCRIPTION OF SUPPORT UNITS	14
4 . EMC EMISSION TEST	15
4.1 CONDUCTED EMISSION MEASUREMENT	15
4.1.1 POWER LINE CONDUCTED EMISSION	15
4.1.2 TEST PROCEDURE	15
4.1.3 DEVIATION FROM TEST STANDARD	15
4.1.4 TEST SETUP	16
4.1.5 EUT OPERATING CONDITIONS	16
4.1.6 EUT TEST CONDITIONS	16
4.1.7 TEST RESULTS	16
4.2 RADIATED EMISSION MEASUREMENT	17
4.2.1 RADIATED EMISSION LIMITS	17
4.2.2 TEST PROCEDURE	18
4.2.3 DEVIATION FROM TEST STANDARD	18
4.2.4 TEST SETUP	18
4.2.5 EUT OPERATING CONDITIONS	20
4.2.6 EUT TEST CONDITIONS	20
4.2.7 TEST RESULTS (9K TO 30MHz)	21
4.2.8 TEST RESULTS (30 TO 1000 MHz)	21
4.2.9 TEST RESULTS (ABOVE 1000 MHz)	21
5 . SPECTRUM BANDWIDTH	22
5.1 APPLIED PROCEDURES / LIMIT	22
5.1.1 TEST PROCEDURE	22
5.1.2 DEVIATION FROM STANDARD	22
5.1.3 TEST SETUP	22
5.1.4 EUT OPERATION CONDITIONS	22
5.1.5 EUT TEST CONDITIONS	23
5.1.6 TEST RESULTS	23
6 . MAXIMUM CONDUCTED OUTPUT POWER	24

Table of Contents	Page
6.1 APPLIED PROCEDURES / LIMIT	24
6.1.1 TEST PROCEDURE	24
6.1.2 DEVIATION FROM STANDARD	25
6.1.3 TEST SETUP	25
6.1.4 EUT OPERATION CONDITIONS	25
6.1.5 EUT TEST CONDITIONS	25
6.1.6 TEST RESULTS	25
7 . POWER SPECTRAL DENSITY TEST	26
7.1 APPLIED PROCEDURES / LIMIT	26
8.1.1 TEST PROCEDURE	26
7.1.1 DEVIATION FROM STANDARD	27
7.1.2 TEST SETUP	27
7.1.3 EUT OPERATION CONDITIONS	27
7.1.4 EUT TEST CONDITIONS	27
7.1.5 TEST RESULTS	27
8 . FREQUENCY STABILITY MEASUREMENT	28
8.1 APPLIED PROCEDURES / LIMIT	28
8.1.1 TEST PROCEDURE	28
8.1.2 DEVIATION FROM STANDARD	28
8.1.3 TEST SETUP	29
8.1.4 EUT OPERATION CONDITIONS	29
8.1.5 EUT TEST CONDITIONS	29
8.1.6 TEST RESULTS	29
9 . MEASUREMENT INSTRUMENTS LIST	30
10 . EUT TEST PHOTOS	32
ATTACHMENT A - CONDUCTED EMISSION	38
ATTACHMENT B - RADIATED EMISSION (9KHZ TO 30MHZ)	41
ATTACHMENT C - RADIATED EMISSION (30MHZ TO 1000MHZ)	46
ATTACHMENT D - RADIATED EMISSION (ABOVE 1000MHZ)	55
ATTACHMENT E - BANDWIDTH	194
ATTACHMENT F - MAXIMUM OUTPUT POWER	217
ATTACHMENT G - POWER SPECTRAL DENSITY	222
ATTACHMENT H - FREQUENCY STABILITY	245

REPORT ISSUED HISTORY

Issued No.	Description	Issued Date
BTL-FCCP-4-1608C052	Original Issue.	Aug. 31, 2016

1. CERTIFICATION

Equipment : Videoconferencing Endpoint
Brand Name : HUAWEI
Model Name : HUAWEI TE10
Applicant : Huawei Technologies Co., Ltd.
Manufacturer : Huawei Technologies Co.,Ltd.
Address : Administration Building, Headquarters of Huawei Technologies Co., Ltd.,
Bantian, Longgang District Shenzhen,518129, P.R.C
Factory : Maintek Computer (Suzhou) Co., Ltd.
Address : No. 233, JinFeng Road, New District, SuZhou, China
Date of Test : Aug. 04, 2016 ~ Aug. 30, 2016
Test Sample : Engineering Sample
Standard(s) : FCC Part15, Subpart E(15.407) / ANSI C63.10-2013

The above equipment has been tested and found compliance with the requirement of the relative standards by BTL Inc.

The test data, data evaluation, and equipment configuration contained in our test report (Ref No. BTL-FCCP-4-1608C052) were obtained utilizing the test procedures, test instruments, test sites that has been accredited by the Authority of TAF according to the ISO-17025 quality assessment standard and technical standard(s).

Test results included in this report is only for the 5GHz band 1 and band 4 part.

2. SUMMARY OF TEST RESULTS

Test procedures according to the technical standard(s):

FCC Part15, Subpart E			
Standard(s) Section	Test Item	Judgment	Remark
15.207	AC Power Line Conducted Emissions	PASS	
15.407(a)	Spectrum Bandwidth	PASS	
15.407(a)	Maximum Conducted Output Power	PASS	
15.407(a)	Power Spectral Density	PASS	
15.407(a)	Radiated Emissions	PASS	
15.407(b)	Band Edge Emissions	PASS	
15.407(g)	Frequency Stability	PASS	
15.203	Antenna Requirements	PASS	

NOTE:

(1) "N/A" denotes test is not applicable in this test report.

2.1 TEST FACILITY

The test facilities used to collect the test data in this report is at the location of No.3,Jinshagang 1st Road, Shixia, Dalang Town, Dongguan, Guangdong, China.

BTL's test firm number for FCC: 319330

2.2 MEASUREMENT UNCERTAINTY

Where relevant, the following measurement uncertainty levels have been estimated for tests performed on the EUT as specified in CISPR 16-4-2. The BTL measurement uncertainty is less than the CISPR 16-4-2 U_{CISPR} requirement.

The reported uncertainty of measurement $y \pm U$, where expanded uncertainty U is based on a standard uncertainty multiplied by a coverage factor of $k=2$, providing a level of confidence of approximately 95 %.

A. Conducted Measurement:

Test Site	Method	Measurement Frequency Range	U, (dB)
DG-C02	CISPR	150 KHz ~ 30MHz	2.32

B. Radiated Measurement:

Test Site	Method	Measurement Frequency Range	Ant. H / V	U, (dB)
DG-CB03	CISPR	9KHz~30MHz	V	3.79
		9KHz~30MHz	H	3.57
		30MHz ~ 200MHz	V	3.82
		30MHz ~ 200MHz	H	3.78
		200MHz ~ 1,000MHz	V	4.10
		200MHz ~ 1,000MHz	H	4.06
		1GHz~18GHz	V	3.12
		1GHz~18GHz	H	3.68
		18GHz~40GHz	V	4.15
		18GHz~40GHz	H	4.14

Note: Unless specifically mentioned, the uncertainty of measurement has not been taken into account to declare the compliance or non-compliance to the specification.

3. GENERAL INFORMATION

3.1 GENERAL DESCRIPTION OF EUT

Equipment	Videoconferencing Endpoint	
Brand Name	HUAWEI	
Model Name	HUAWEI TE10	
Mode Different	N/A	
Product Description	Operation Frequency	UNII-1: 5150-5250MHz UNII-3: 5725-5850MHz
	Modulation Type	OFDM
	Bit Rate of Transmitter	150Mbps
	Output Power (Max.)for UNII-1	802.11A: 12.00dBm 802.11N (20M): 11.98dBm 802.11N (40M): 11.97dBm 802.11AC (VHT20MHz): 12.00dBm 802.11AC (VHT40MHz): 11.91dBm 802.11AC (VHT80MHz): 11.80dBm
	Output Power (Max.)for UNII-3	802.11A: 11.96dBm 802.11N (20M): 11.65dBm 802.11N (40M): 11.94dBm 802.11AC (VHT20MHz): 11.98dBm 802.11AC (VHT40MHz): 11.98dBm 802.11AC (VHT80MHz): 12.07dBm
	Power Source	DC Voltage supplied from adapter. Model: MU12AR120100-A2
Power Rating	I/P: 100-240V~50/60Hz 0.3A O/P: 12V --- 1A	

Note:

- For a more detailed features description, please refer to the manufacturer's specifications or the user's manual.
- Channel List:

802.11A 802.11N 20MHz 802.11AC (VHT20MHz)		802.11N 40MHz 802.11AC (VHT40MHz)		802.11AC (VHT80MHz)	
UNII-1		UNII-1		UNII-1	
Channel	Frequency (MHz)	Channel	Frequency (MHz)	Channel	Frequency (MHz)
36	5180	38	5190	42	5210
40	5200	46	5230		
44	5220				
48	5240				

802.11A 802.11N 20MHz 802.11AC (VHT20MHz)		802.11N 40MHz 802.11AC (VHT40MHz)		802.11AC (VHT80MHz)	
UNII-3		UNII-3		UNII-3	
Channel	Frequency (MHz)	Channel	Frequency (MHz)	Channel	Frequency (MHz)
149	5745	151	5755	155	5775
153	5765	159	5795		
157	5785				
161	5805				
165	5825				

4. Antenna Specification:

Ant.	Brand	Model Name	Antenna Type	Connector	Gain (dBi)
1	N/A	N/A	Internal	N/A	3

3.2 DESCRIPTION OF TEST MODES

To investigate the maximum EMI emission characteristics generates from EUT, the test system was pre-scanning tested base on the consideration of following EUT operation mode or test configuration mode which possible have effect on EMI emission level. Each of these EUT operation mode(s) or test configuration mode(s) mentioned above was evaluated respectively.

Pretest Mode	Description
Mode 1	TX A Mode / CH36, CH40, CH48 (UNII-1)
Mode 2	TX N20 Mode / CH36, CH40, CH48 (UNII-1)
Mode 3	TX N40 Mode / CH38, CH46 (UNII-1)
Mode 4	TX AC(VHT20) Mode / CH36, CH40, CH48 (UNII-1)
Mode 5	TX AC(VHT40) Mode / CH38, CH46 (UNII-1)
Mode 6	TX AC(VHT80) Mode / CH42 (UNII-1)
Mode 7	TX A Mode / CH149,CH157,CH165 (UNII-3)
Mode 8	TX N20 Mode / CH149,CH157,CH165 (UNII-3)
Mode 9	TX N40 Mode / CH151,CH159 (UNII-3)
Mode 10	TX AC(VHT20) Mode / CH149,CH157,CH165 (UNII-3)
Mode 11	TX AC(VHT40) Mode / CH151,CH159 (UNII-3)
Mode 12	TX AC(VHT80) Mode / CH155 (UNII-3)
Mode 13	TX Mode

The EUT system operated these modes were found to be the worst case during the pre-scanning test as following:

For Conducted Test	
Final Test Mode	Description
Mode 13	TX Mode

For Radiated Test	
Final Test Mode	Description
Mode 1	TX A Mode / CH36, CH40, CH48 (UNII-1)
Mode 2	TX N20 Mode / CH36, CH40, CH48 (UNII-1)
Mode 3	TX N40 Mode / CH38, CH46 (UNII-1)
Mode 4	TX AC(VHT20) Mode / CH36, CH40, CH48 (UNII-1)
Mode 5	TX AC(VHT40) Mode / CH38, CH46 (UNII-1)
Mode 6	TX AC(VHT80) Mode / CH42 (UNII-1)
Mode 7	TX A Mode / CH149,CH157,CH165 (UNII-3)
Mode 8	TX N20 Mode / CH149,CH157,CH165 (UNII-3)
Mode 9	TX N40 Mode / CH151,CH159 (UNII-3)
Mode 10	TX AC(VHT20) Mode / CH149,CH157,CH165 (UNII-3)
Mode 11	TX AC(VHT40) Mode / CH151,CH159 (UNII-3)
Mode 12	TX AC(VHT80) Mode / CH155 (UNII-3)

Note:

- (1) For radiated below 1GHz test, the 802.11A mode is found to be the worst case and recorded.
- (2) The measurements for radiated emission, the worst case are high and low channels, only worst case was documented.

3.3 TABLE OF PARAMETERS OF TEST SOFTWARE SETTING

During testing channel & power controlling software provided by the customer was used to control the operating channel as well as the output power level. The RF output power selection is for the setting of RF output power expected by the customer and is going to be fixed on the firmware of the final end product

UNII-1			
Test Software Version	DutApi_w8887_BrdigeEth		
Frequency (MHz)	5180	5200	5240
A Mode	10	10	10
N20 Mode	10	10	10
Frequency (MHz)	5190	5230	
N40 Mode	10	10	

UNII-3			
Test Software Version	DutApi_w8887_BrdigeEth		
Frequency (MHz)	5745	5785	5825
A Mode	11	11	11
N20 Mode	11	11	11
Frequency (MHz)	5755	5795	
N40 Mode	11	11	

UNII-1			
Test Software Version	DutApi_w8887_BrdigeEth		
Frequency (MHz)	5180	5200	5240
AC(VHT20) Mode	10	10	10
Frequency (MHz)	5190	5230	
AC(VHT40) Mode	10	10	
Frequency (MHz)	5210		
AC(VHT80) Mode	9		

UNII-3			
Test Software Version	DutApi_w8887_BrdigeEth		
Frequency (MHz)	5745	5785	5825
AC(VHT20) Mode	11	11	11
Frequency (MHz)	5755	5795	
AC(VHT40) Mode	11	11	
Frequency (MHz)	5775		
AC(VHT80) Mode	9		

3.4 BLOCK DIAGRAM SHOWING THE CONFIGURATION OF SYSTEM TESTED

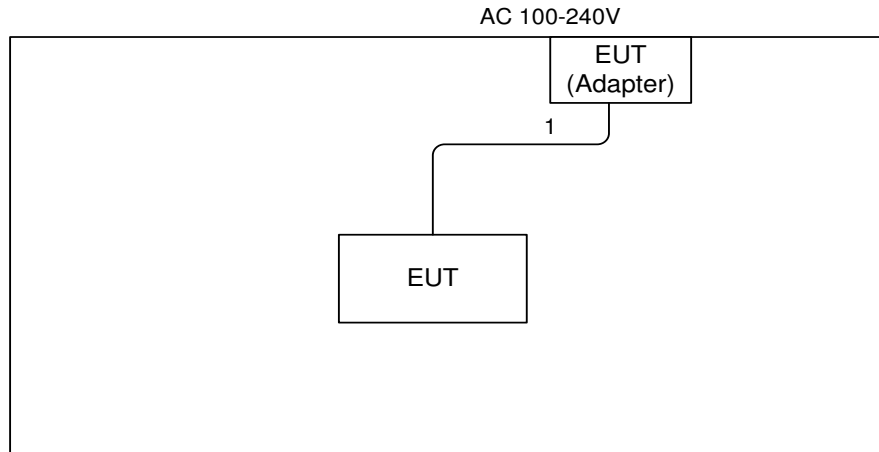

3.5 DESCRIPTION OF SUPPORT UNITS

The EUT has been tested as an independent unit together with other necessary accessories or support units. The following support units or accessories were used to form a representative test configuration during the tests.

Item	Equipment	Mfr/Brand	Model/Type No.	FCC ID	Series No.
-	-	-	-	-	-

Item	Shielded Type	Ferrite Core	Length	Note
1	NO	NO	1.5m	Power Cable

4. EMC EMISSION TEST

4.1 CONDUCTED EMISSION MEASUREMENT

4.1.1 POWER LINE CONDUCTED EMISSION (Frequency Range 150kHz-30MHz)

FREQUENCY (MHz)	Class A (dBuV)		Class B (dBuV)	
	Quasi-peak	Average	Quasi-peak	Average
0.15 -0.5	79.00	66.00	66 - 56 *	56 - 46 *
0.50 -5.0	73.00	60.00	56.00	46.00
5.0 -30.0	73.00	60.00	60.00	50.00

Note:

- (1) The tighter limit applies at the band edges.
- (2) The limit of " * " marked band means the limitation decreases linearly with the logarithm of the frequency in the range.
- (2) The test result calculated as following:
 Measurement Value = Reading Level + Correct Factor
 Correct Factor = Insertion Loss + Cable Loss + Attenuator Factor(if use)
 Margin Level = Measurement Value - Limit Value

4.1.2 TEST PROCEDURE

- a. The EUT was placed 0.8 meters from the horizontal ground plane with EUT being connected to the power mains through a line impedance stabilization network (LISN). All other support equipments powered from additional LISN(s). The LISN provide 50 Ohm/ 50uH of coupling impedance for the measuring instrument.
- b. Interconnecting cables that hang closer than 40 cm to the ground plane shall be folded back and forth in the center forming a bundle 30 to 40 cm long.
- c. I/O cables that are not connected to a peripheral shall be bundled in the center. The end of the cable may be terminated, if required, using the correct terminating impedance. The overall length shall not exceed 1 m.
- d. LISN at least 80 cm from nearest part of EUT chassis.
- e. For the actual test configuration, please refer to the related Item –EUT Test Photos.

4.1.3 DEVIATION FROM TEST STANDARD

No deviation

4.1.4 TEST SETUP

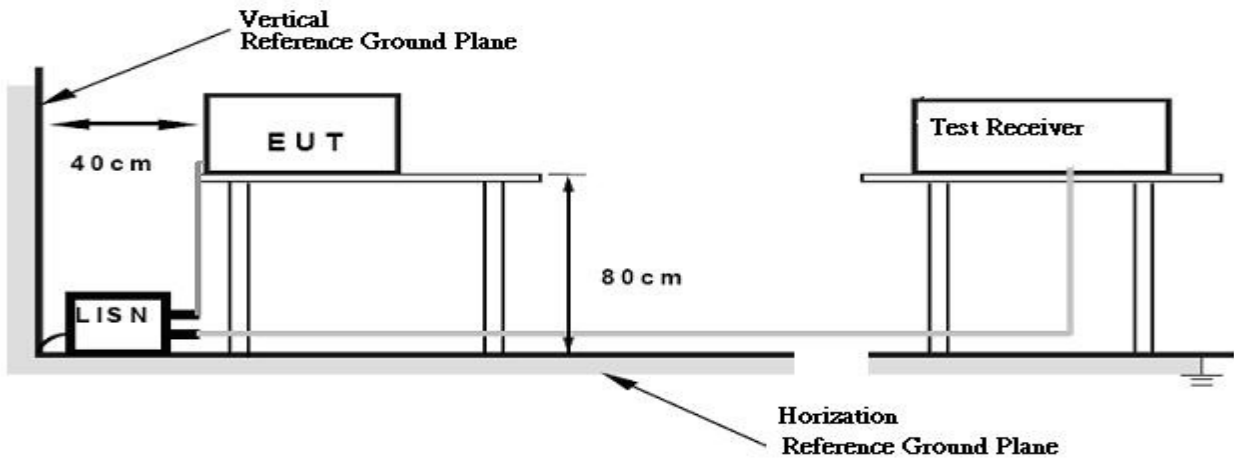

4.1.5 EUT OPERATING CONDITIONS

The EUT was configured for testing in a typical fashion (as a customer would normally use it). The EUT has been programmed to continuously transmit during test. This operating condition was tested and used to collect the included data.

The EUT was programmed to be in continuously transmitting/TX Mode mode.

4.1.6 EUT TEST CONDITIONS

Temperature: 25°C Relative Humidity: 53% Test Voltage: AC 120V/60Hz

4.1.7 TEST RESULTS

Please refer to the Attachment A.

Remark:

- (1) All readings are QP Mode value unless otherwise stated AVG in column of『Note』. If the QP Mode Measured value compliance with the QP Limits and lower than AVG Limits, the EUT shall be deemed to meet both QP & AVG Limits and then only QP Mode was measured, but AVG Mode didn't perform. In this case, a “*” marked in AVG Mode column of Interference Voltage Measured.
- (2) Measuring frequency range from 150kHz to 30MHz.

4.2 RADIATED EMISSION MEASUREMENT

4.2.1 RADIATED EMISSION LIMITS

In case the emission fall within the restricted band specified on 15.205(a), then the 15.209(a) limit in the table below has to be followed.

Frequencies (MHz)	Field Strength (micorvolts/meter)	Measurement Distance (meters)
0.009~0.490	2400/F(kHz)	300
0.490~1.705	24000/F(kHz)	30
1.705~30.0	30	30
30~88	100	3
88~216	150	3
216~960	200	3
Above 960	500	3

Note:

- (1) The limit for radiated test was performed according to FCC PART 15C.
- (2) The tighter limit applies at the band edges.

LIMITS OF UNWANTED EMISSION OUT OF THE RESTRICTED BANDS

Frequencies (MHz)	EIRP Limit (dBm)	Band edge at 3m (dBμV/m)	Harmonic at 1.5m (dBμV/m)
5150-5250	-27	68.3	74.3 (Note 3)
5250-5350	-27	68.3	74.3 (Note 3)
5470-5725	-27	68.3	74.3 (Note 3)
5725-5850	-27(Note 2)	68.3	74.3 (Note 3)
	10(Note 2)	105.3	111.3(Note 3)
	15.6(Note 2)	110.9	116.9(Note 3)
	27(Note 2)	122.3	128.3(Note 3)

Note:

1. The following formula is used to convert the equipment isotropic radiated power (eirp) to field strength: $E = \frac{1000000\sqrt{30P}}{3}$ μV/m, where P is the eirp (Watts)
2. According to FCC 16-24, All emissions shall be limited to a level of -27 dBm/MHz at 75 MHz or more above or below the band edge increasing linearly to 10 dBm/MHz at 25 MHz above or below the band edge, and from 25MHz above or below the band edge increasing linearly to a level of 15.6 dBm/MHz at 5 MHz above or below the band edge, and from 5 MHz above or below the band edge increasing linearly to a level of 27dBm/MHz at the band edge.

3. $FS_{\text{limit}} = FS_{\text{max}} - 20\log\left(\frac{d_{\text{limit}}}{d_{\text{measure}}}\right)$ $20\log d_{\text{limit}}/d_{\text{measure}}=20\log 3/1.5=6\text{dB}$.

4.2.2 TEST PROCEDURE

- a. The measuring distance of 3 m shall be used for measurements. The EUT was placed on the top of a rotating table 0.8 meter above the ground at a 3 meter semi-anechoic chamber. The table was rotated 360 degrees to determine the position of the highest radiation.(below 1GHz)
- b. The measuring distance of 3m or 1.5 m shall be used for measurements. The EUT was placed on the top of a rotating table 1.5 meter above the ground at a 3 meter semi-anechoic chamber. The table was rotated 360 degrees to determine the position of the highest radiation.(above 1GHz)
- c. The height of the equipment or of the substitution antenna shall be 0.8 m or 1.5m, the height of the test antenna shall vary between 1 m to 4 m. Both horizontal and vertical polarizations of the antenna are set to make the measurement.
- d. The initial step in collecting radiated emission data is a receiver peak detector mode pre-scanning the measurement frequency range. Significant peaks are then marked and then Quasi Peak detector mode re-measured.
- e. All readings are Peak unless otherwise stated QP in column of Note. Peak denotes that the Peak reading compliance with the QP Limits and then QP Mode measurement didn't perform. (below 1GHz)
- f. All readings are Peak Mode value unless otherwise stated AVG in column of Note. If the Peak Mode Measured value compliance with the Peak Limits and lower than AVG Limits, the EUT shall be deemed to meet both Peak & AVG Limits and then only Peak Mode was measured, but AVG Mode didn't perform. (above 1GHz)
- g. For the actual test configuration, please refer to the related Item –EUT Test Photos.

4.2.3 DEVIATION FROM TEST STANDARD

No deviation

4.2.4 TEST SETUP

(A) Radiated Emission Test Set-Up Frequency Below 1GHz

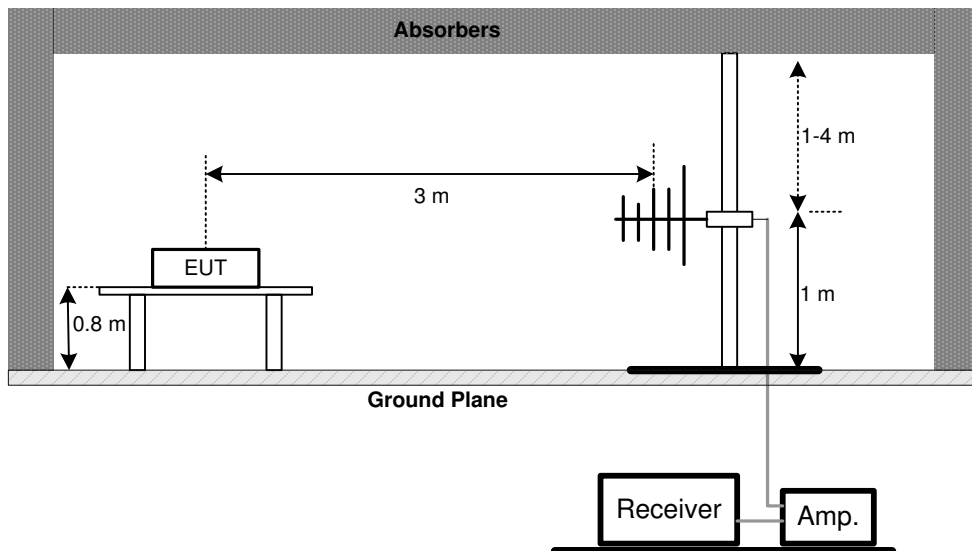

(B) Radiated Emission Test Set-Up Frequency Above 1 GHz
Band edge

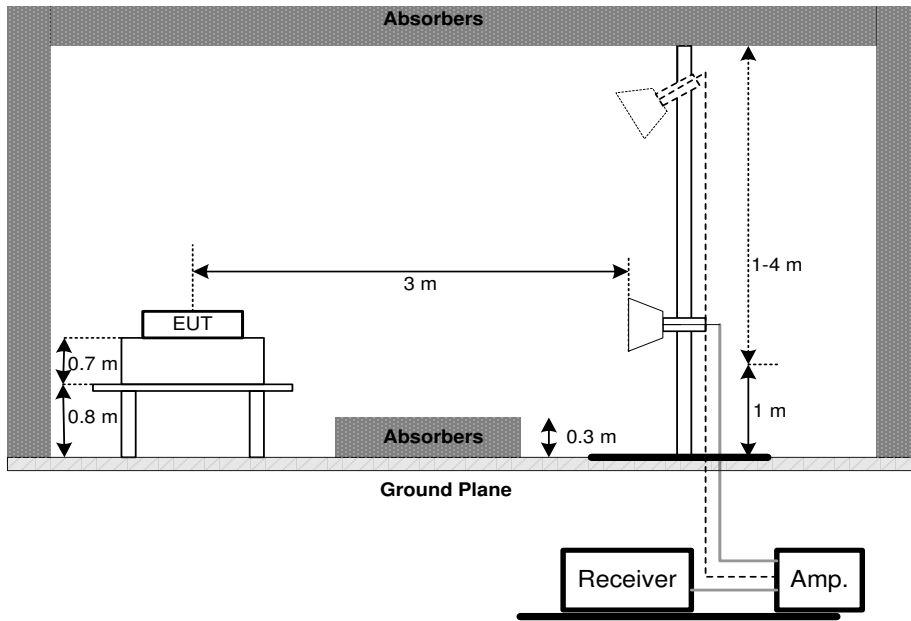

Harmonic

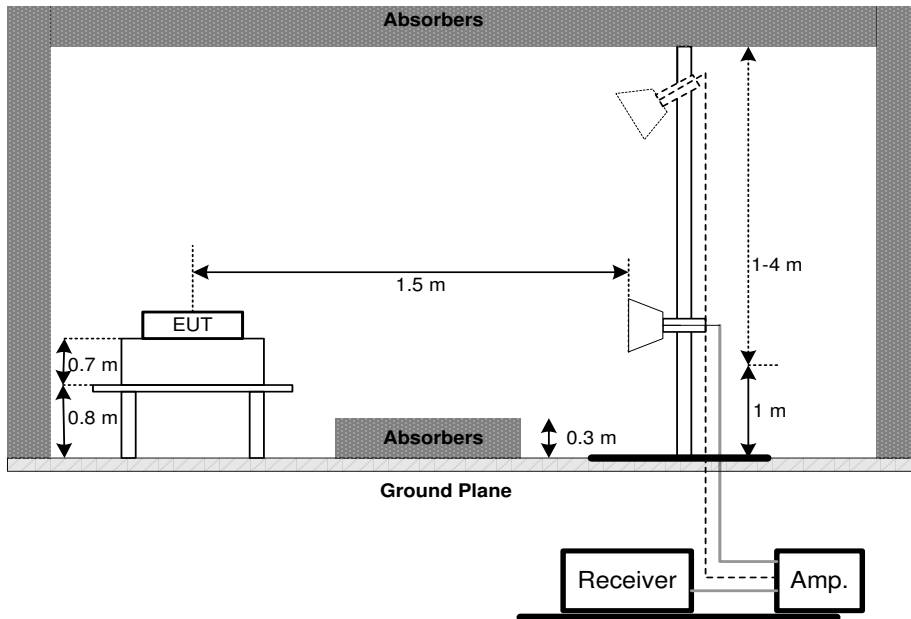

(C) Radiated emissions below 30MHz

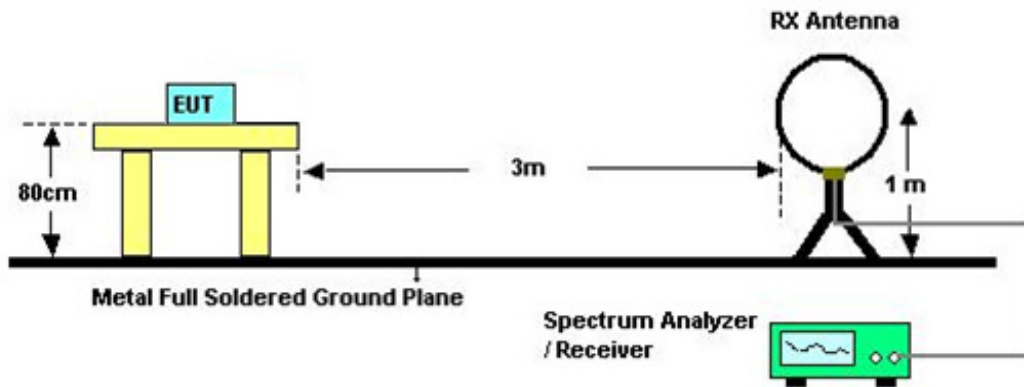

4.2.5 EUT OPERATING CONDITIONS

The EUT tested system was configured as the statements of 4.1.5 unless otherwise a special operating condition is specified in the follows during the testing.

4.2.6 EUT TEST CONDITIONS

Temperature: 28°C Relative Humidity: 56% Test Voltage: AC 120V/60Hz

4.2.7 TEST RESULTS (9K TO 30MHz)

Please refer to the Attachment B

Remark:

- (1) The amplitude of spurious emissions which are attenuated by more than 20 dB below the permissible value has no need to be reported.
- (2) Distance extrapolation factor = $40 \log (\text{specific distance} / \text{test distance})$ (dB);
- (3) Limit line = specific limits (dBuV) + distance extrapolation factor.

4.2.8 TEST RESULTS (30 TO 1000 MHz)

Please refer to the Attachment C.

Remark:

- (1) Measuring frequency range from 30MHz to 1000MHz ◦
- (2) If the peak scan value lower limit more than 20dB, then this signal data does not show in table ◦

4.2.9 TEST RESULTS (ABOVE 1000 MHz)

Please refer to the Attachment D.

Remark:

- (1) Radiated emissions measured in frequency range above 1000MHz were made with an instrument using Peak detector mode and AV detector mode of the emission ◦
- (2) Data of measurement within this frequency range shown “ * ” in the table above means the reading of emissions are attenuated more than 20dB below the permissible limits or the field strength is too small to be measured.
- (3) A preamp and high pass filter were used for this test in order to provide sufficient measurement sensitivity.
- (4) EUT Orthogonal Axes:
“X” - denotes Laid on Table ; “Y” - denotes Vertical Stand ; “Z” - denotes Side Stand
- (5) During the measurements above 1GHz it is taken care of that the EUT is always within the 3dB cone of radiation BW of the used antenna.
- (6) No limit: This is fundamental signal, the judgment is not applicable.
For fundamental signal judgment was referred to Peak output test.

5. SPECTRUM BANDWIDTH

5.1 APPLIED PROCEDURES / LIMIT

FCC Part15, Subpart E			
Test Item	Limit	Frequency Range (MHz)	Result
Bandwidth	26 dB Bandwidth	5150-5250	PASS
	Minimum 500kHz 6dB Bandwidth	5725-5850	PASS

5.1.1 TEST PROCEDURE

a. The EUT was directly connected to the spectrum analyzer and antenna output port as show in the block diagram below,

b.

Spectrum Parameters	Setting
Attenuation	Auto
Span Frequency	> 26dB Bandwidth
RBW	300 kHz
VBW	1000 kHz
Detector	Peak
Trace	Max Hold
Sweep Time	Auto

c. Measured the spectrum width with power higher than 26dB below carrier

5.1.2 DEVIATION FROM STANDARD

No deviation.

5.1.3 TEST SETUP



5.1.4 EUT OPERATION CONDITIONS

The EUT tested system was configured as the statements of 4.1.5 unless otherwise a special operating condition is specified in the follows during the testing.

5.1.5 EUT TEST CONDITIONS

Temperature: 28°C Relative Humidity: 56% Test Voltage: AC 120V/60Hz

5.1.6 TEST RESULTS

Please refer to the Attachment E.

6. MAXIMUM CONDUCTED OUTPUT POWER

6.1 APPLIED PROCEDURES / LIMIT

FCC Part15, Subpart E			
Test Item	Limit	Frequency Range (MHz)	Result
Conducted Output Power	Fixed:1 Watt (30dBm) Mobile and portable: 250mW (24dBm)	5150-5250	PASS
	1 Watt (30dBm)	5725-5850	PASS
Note: The maximum e.i.r.p at anyelevation angle above 30 degrees as measured from the horizon must not exceed 125mW(21dBm)			

6.1.1 TEST PROCEDURE

- a. The EUT was directly connected to the power meter and antenna output port as show in the block diagram below,

b.

Spectrum Parameter	Setting
Attenuation	Auto
Span Frequency	Encompass the entire emissions bandwidth (EBW) of the signal
RBW	= 1MHz.
VBW	\geq 3MHz.
Detector	RMS
Trace	Max Hold
Sweep Time	auto

- c. Test was performed in accordance with method of KDB 789033 D02.

6.1.2 DEVIATION FROM STANDARD

No deviation.

6.1.3 TEST SETUP



6.1.4 EUT OPERATION CONDITIONS

The EUT tested system was configured as the statements of 4.1.5 unless otherwise a special operating condition is specified in the follows during the testing.

6.1.5 EUT TEST CONDITIONS

Temperature: 28°C Relative Humidity: 56% Test Voltage: AC 120V/60Hz

6.1.6 TEST RESULTS

Please refer to the Attachment F.

7. POWER SPECTRAL DENSITY TEST

7.1 APPLIED PROCEDURES / LIMIT

FCC Part15, Subpart E			
Test Item	Limit	Frequency Range (MHz)	Result
Power Spectral Density	Other then Mobile and portable:17dBm/MHz Mobile and portable:11dBm/MHz	5150-5250	PASS
	30dBm/500kHz	5725-5850	PASS

8.1.1 TEST PROCEDURE

a. The EUT was directly connected to the spectrum analyzer and antenna output port as show in the block diagram below,

b.

Spectrum Parameter	Setting
Attenuation	Auto
Span Frequency	Encompass the entire emissions bandwidth (EBW) of the signal
RBW	= 1MHz.
VBW	≥ 3MHz.
Detector	RMS
Trace average	100 trace
Sweep Time	Auto

Note:

1. For UNII-3, according to KDB publication 789033 D02 General UNII Test Procedures New Rules, section II.F.5., it is acceptable to set RBW at 1MHz and VBW at 3MHz if the spectrum analyzer does not have 500kHz RBW.
2. The value measured with RBW=1MHz is to be added with $10\log(500\text{kHz}/1\text{MHz})$ which is -3dB. For example, if the measured value is +10dBm using RBW=1MHz (that is +10dBm/MHz), then the converted value will be +7dBm/500kHz.

7.1.1 DEVIATION FROM STANDARD

No deviation.

7.1.2 TEST SETUP

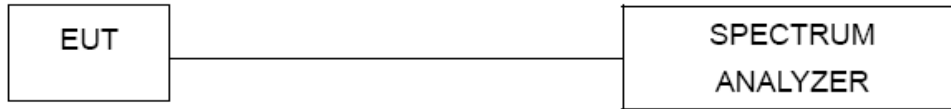

7.1.3 EUT OPERATION CONDITIONS

The EUT tested system was configured as the statements of 4.1.5 unless otherwise a special operating condition is specified in the follows during the testing.

7.1.4 EUT TEST CONDITIONS

Temperature: 28°C Relative Humidity: 56% Test Voltage: AC 120V/60Hz

7.1.5 TEST RESULTS

Please refer to the Attachment G.

8. FREQUENCY STABILITY MEASUREMENT

8.1 APPLIED PROCEDURES / LIMIT

FCC Part15, Subpart E			
Test Item	Limit	Frequency Range (MHz)	Result
Frequency Stability	Specified in the user's manual	5150-5250	PASS
		5725-5850	PASS

8.1.1 TEST PROCEDURE

a. The EUT was directly connected to the spectrum analyzer and antenna output port as show in the block diagram below,

b.

Spectrum Parameter	Setting
Attenuation	Auto
Span Frequency	Entire absence of modulation emissions bandwidth
RBW	10 kHz
VBW	10 kHz
Sweep Time	Auto

c. The test extreme voltage is to change the primary supply voltage from 85 to 115 percent of the nominal value.

d. User manual temperature is 0°C~40°C.

8.1.2 DEVIATION FROM STANDARD

No deviation.

8.1.3 TEST SETUP

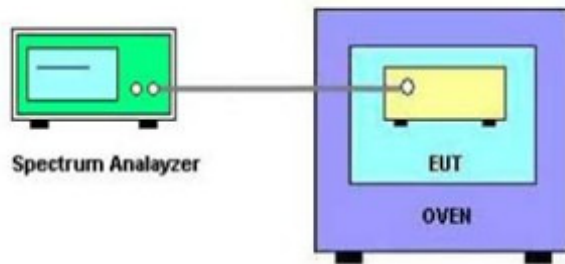

8.1.4 EUT OPERATION CONDITIONS

The EUT tested system was configured as the statements of 4.1.5 unless otherwise a special operating condition is specified in the follows during the testing.

8.1.5 EUT TEST CONDITIONS

Temperature: 25°C Relative Humidity: 55% Test Voltage: AC 120V/60Hz

8.1.6 TEST RESULTS

Please refer to the Attachment H.

9. MEASUREMENT INSTRUMENTS LIST

Conducted Emission Measurement					
Item	Kind of Equipment	Manufacturer	Type No.	Serial No.	Calibrated until
1	LISN	EMCO	3816/2	0052765	Mar. 27, 2017
2	LISN	R&S	ENV216	101447	Mar. 27, 2017
3	Test Cable	emci	RG223(9KHz-30 MHz)	C_17	Mar. 10, 2017
4	EMI Test Receiver	R&S	ESCI	100382	Mar. 27, 2017
5	50Ω Terminator	SHX	TF2-3G-A	08122901	Mar. 27, 2017
6	Measurement Software	Farad	EZ-EMC Ver.NB-03A1-01	N/A	N/A

Radiated Emission Measurement					
Item	Kind of Equipment	Manufacturer	Type No.	Serial No.	Calibrated until
1	Antenna	Schwarzbeck	VULB9160	9160-3232	Mar. 27, 2017
2	Amplifier	HP	8447D	2944A09673	Nov. 09, 2016
3	Receiver	AGILENT	N9038A	MY52130039	Oct. 11, 2016
4	Test Cable	emci	LMR-400(30MHz-1GHz)	C-01	Jun. 26, 2017
5	Controller	CT	SC100	N/A	N/A
6	Measurement Software	Farad	EZ-EMC Ver.NB-03A1-01	N/A	N/A
7	Antenna	ETS	3115	00075789	Mar. 27, 2017
8	Amplifier	Agilent	8449B	3008A02274	Nov. 01, 2016
9	Receiver	AGILENT	N9038A	MY52130039	Oct. 11, 2016
10	Test Cable	emci	EMC104-SM-S M-10000(1GHz-26.5GHz)	C-68	Jun. 26, 2017
11	Broad-Band Horn Antenna	Schwarzbeck	BBHA 9170	9170319	Mar. 27, 2017
12	Microwave Preamplifier With Adaptor	EMC INSTRUMENT	EMC2654045	980039 & HA01	Mar. 27, 2017
13	Active Loop Antenna	R&S	HFH2-Z2	830749/020	Sep. 07, 2016

Spectrum Bandwidth Measurement					
Item	Kind of Equipment	Manufacturer	Type No.	Serial No.	Calibrated until
1	Spectrum Analyzer	R&S	FSP 40	100185	Oct. 11, 2016

Maximum Conducted Output Power Measurement					
Item	Kind of Equipment	Manufacturer	Type No.	Serial No.	Calibrated until
1	power Meter	ANRITSU	ML2495A	1128009	Mar. 27, 2017
2	Pulse Power Sensor	ANRITSU	MA 2411B	1027500	Mar. 27, 2017

Power Spectral Density Measurement					
Item	Kind of Equipment	Manufacturer	Type No.	Serial No.	Calibrated until
1	Spectrum Analyzer	R&S	FSP 40	100185	Oct. 11, 2016

Frequency Stability Measurement					
Item	Kind of Equipment	Manufacturer	Type No.	Serial No.	Calibrated until
1	Spectrum Analyzer	R&S	FSP 40	100185	Oct. 11, 2016
2	Const Temp. & Humidity Chamber	Giant Force	ITH-225-20-S	IAB0309-001	Dec. 04 2016

Remark: "N/A" denotes no model name, serial no. or calibration specified.
 All calibration period of equipment list is one year.

10. EUT TEST PHOTOS

Conducted Measurement Photos



9KHz to 30MHz Radiated Measurement Photos



30MHz to 1000MHz Radiated Measurement Photos

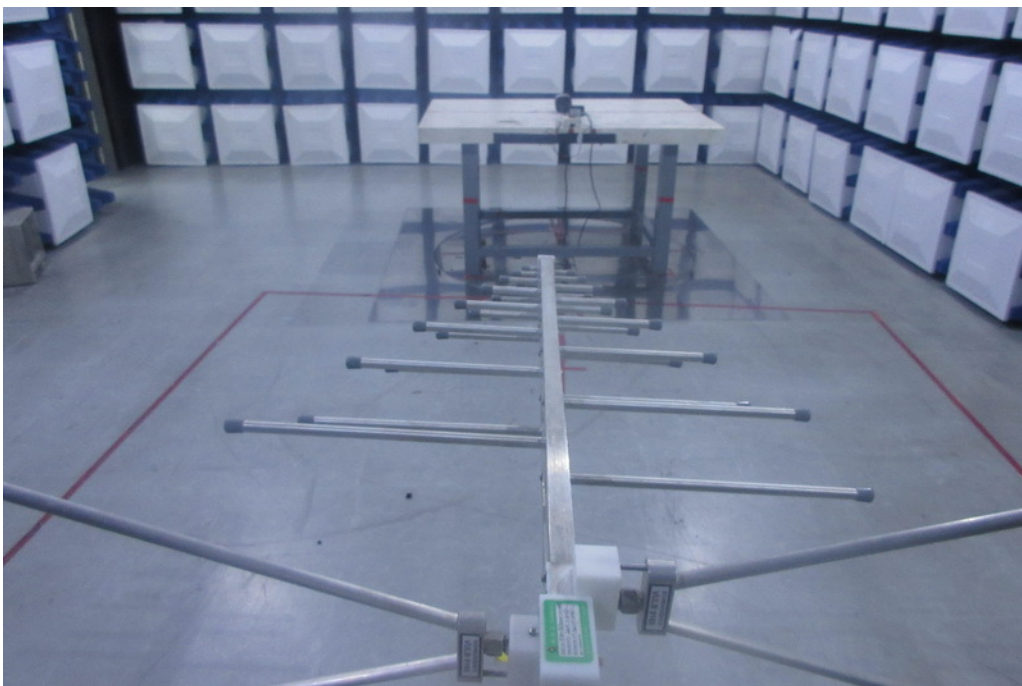

1GHz to 18GHz Radiated Measurement Photos

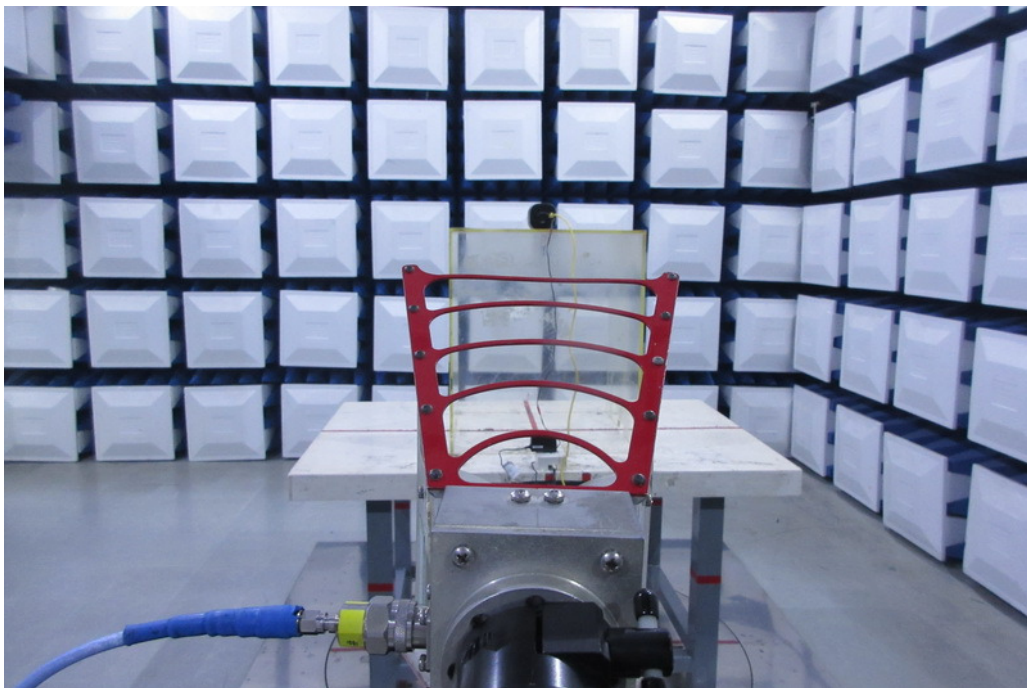
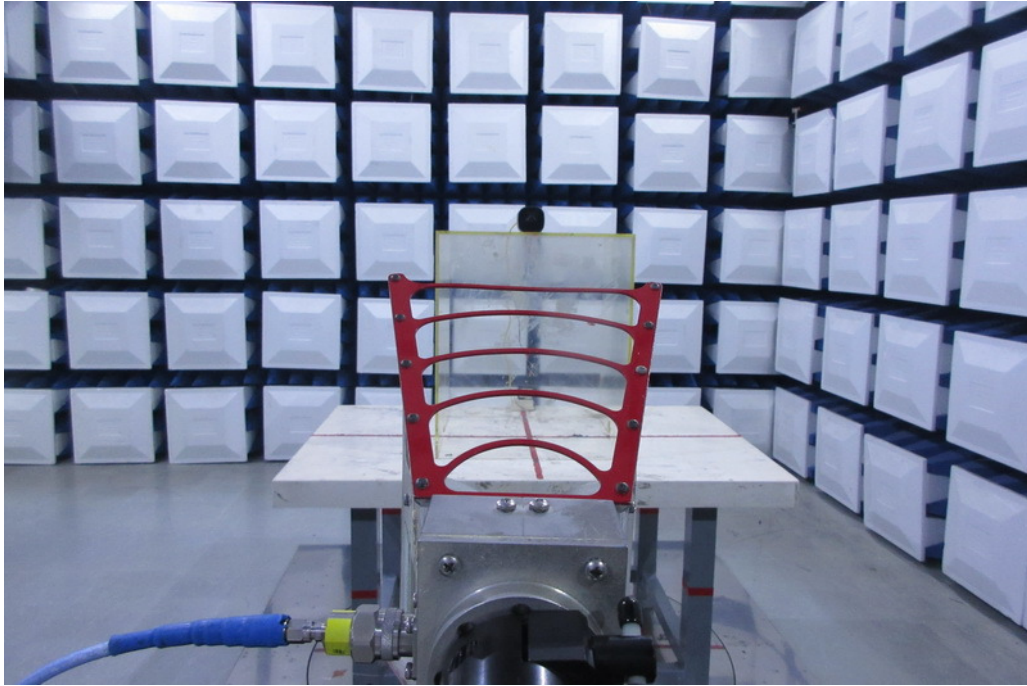

18GHz to 40GHz Radiated Measurement Photos

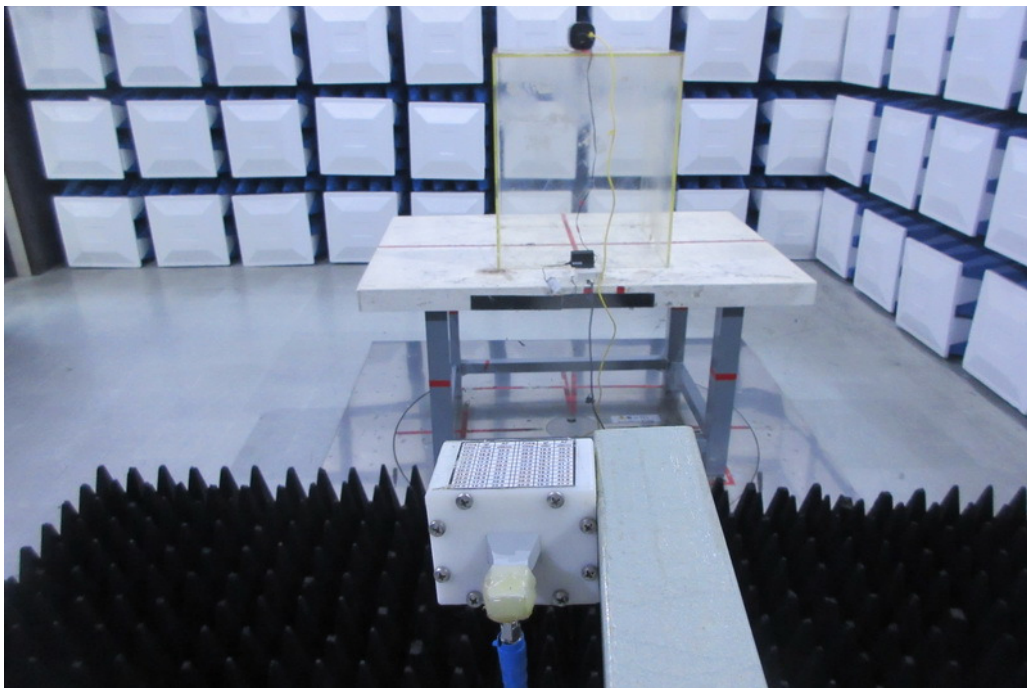
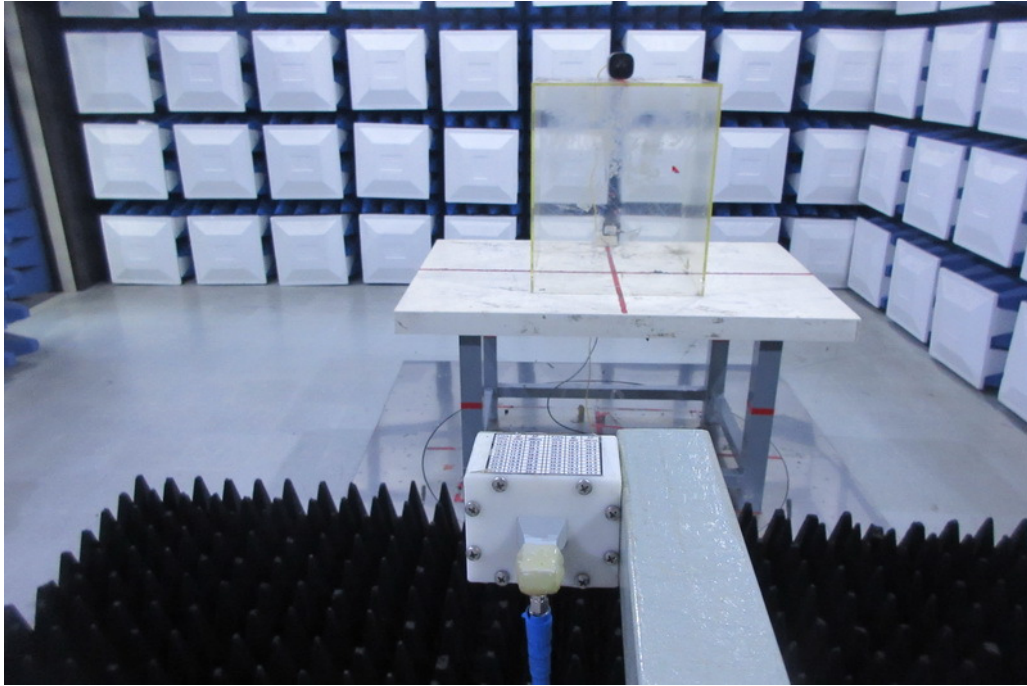

Band Edge Measurement Photos

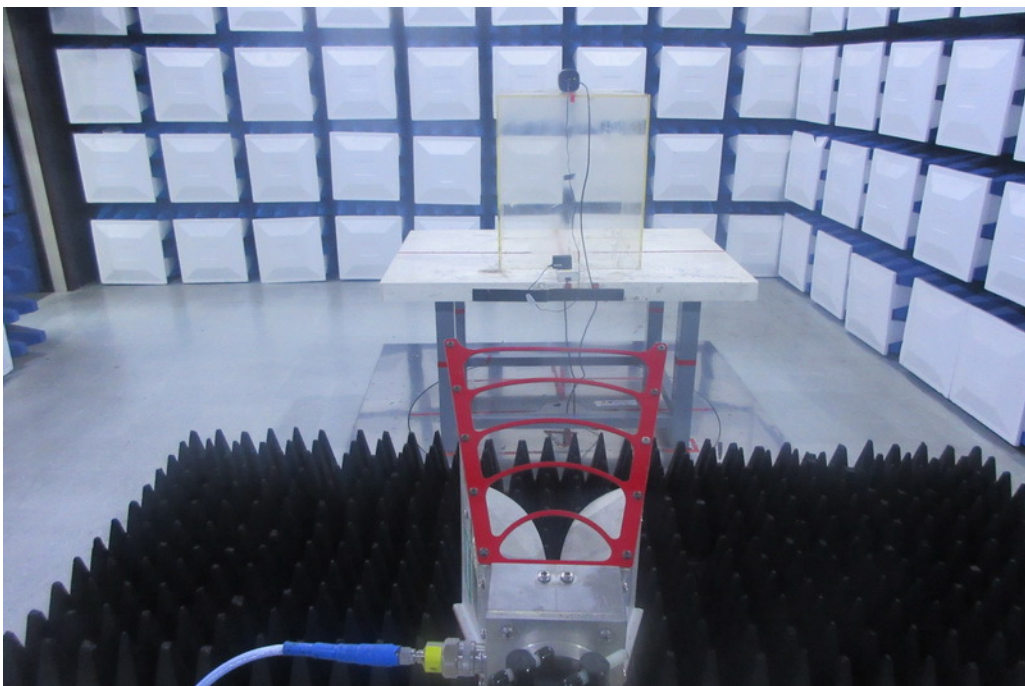
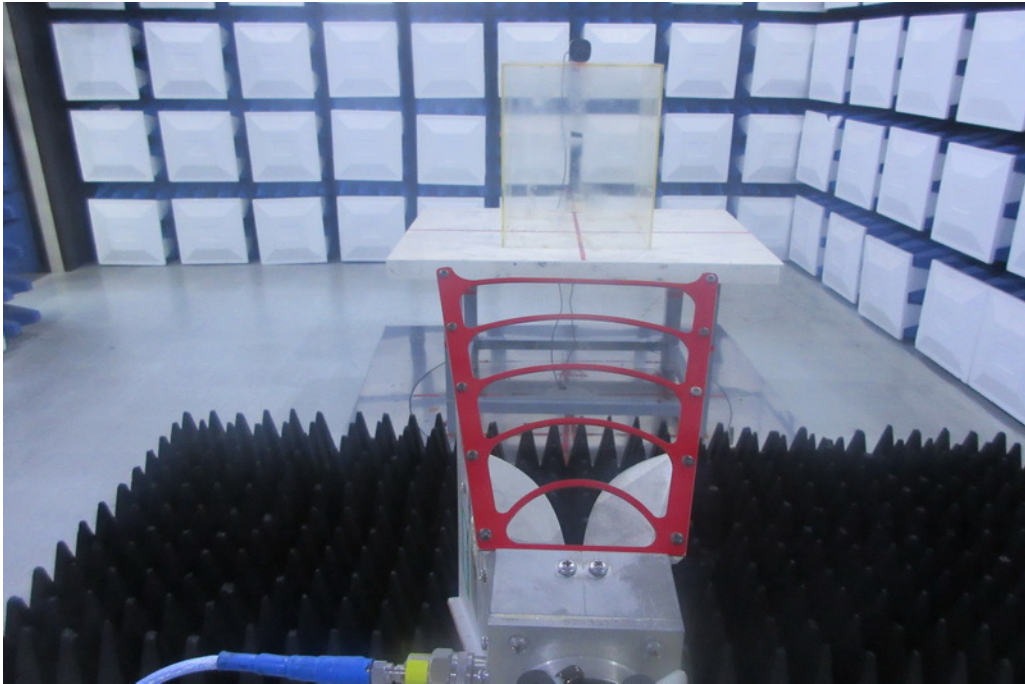

ATTACHMENT A - CONDUCTED EMISSION

Test Mode: TX Mode

Line

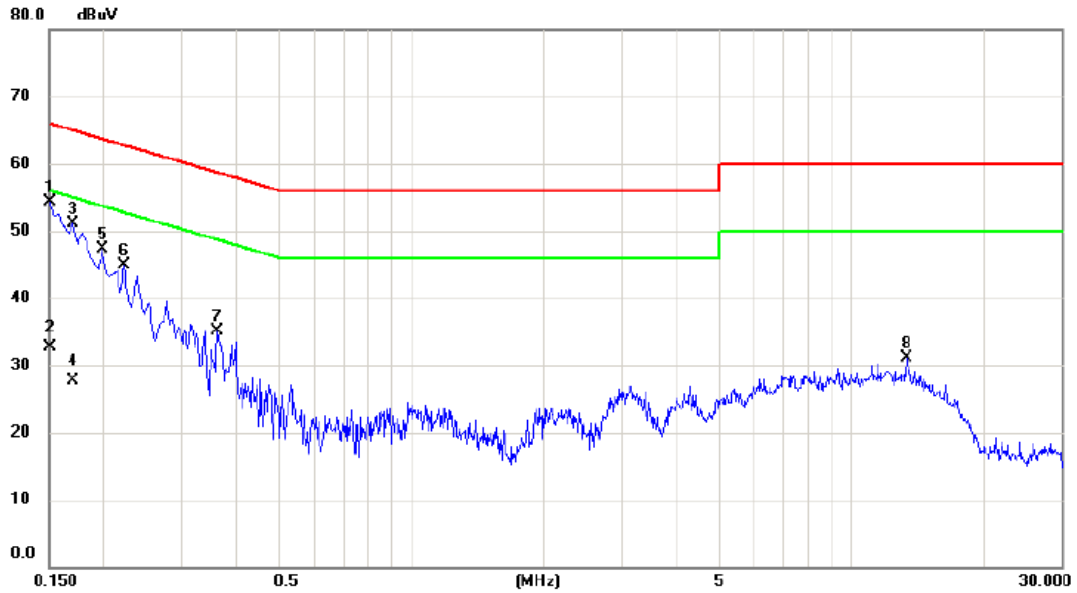

No.	Mk.	Freq. MHz	Reading Level dBuV	Correct Factor dB	Measure- ment dBuV	Limit dBuV	Margin dB	Detector	Comment
1	*	0.1500	44.81	9.52	54.33	66.00	-11.67	peak	
2		0.1500	23.20	9.52	32.72	56.00	-23.28	AVG	
3		0.1700	41.68	9.52	51.20	64.96	-13.76	peak	
4		0.1700	18.10	9.52	27.62	54.96	-27.34	AVG	
5		0.1980	37.77	9.53	47.30	63.69	-16.39	peak	
6		0.2220	35.37	9.53	44.90	62.74	-17.84	peak	
7		0.3620	25.48	9.54	35.02	58.68	-23.66	peak	
8		13.3860	20.77	10.31	31.08	60.00	-28.92	peak	

Test Mode: TX Mode

Neutral

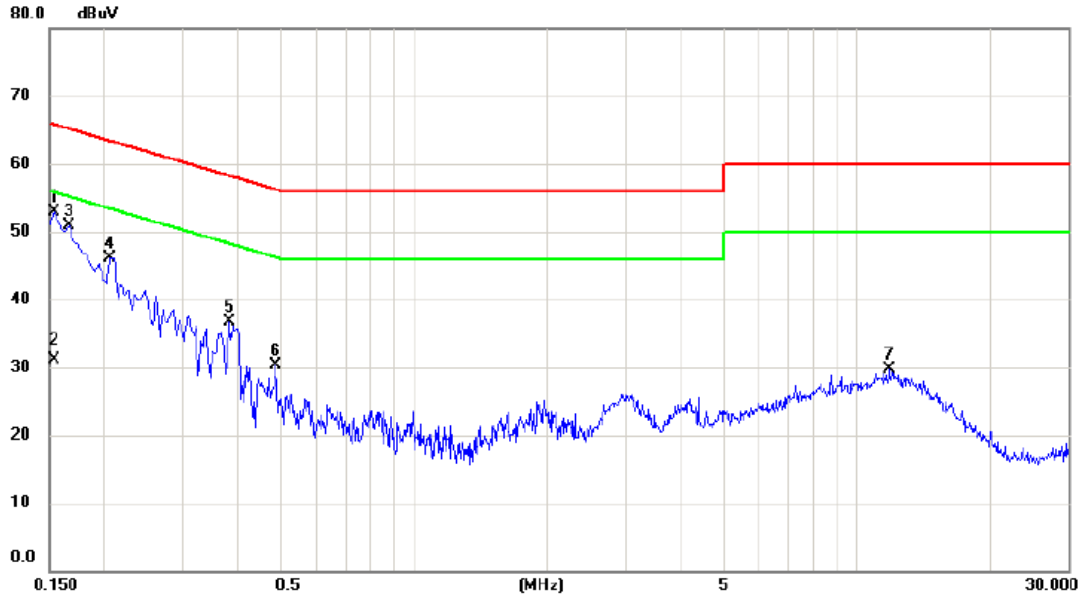

No.	Mk.	Freq. MHz	Reading Level dBuV	Correct Factor dB	Measure- ment dBuV	Limit dBuV	Margin dB	Detector	Comment
1	*	0.1540	43.45	9.50	52.95	65.78	-12.83	peak	
2		0.1540	21.70	9.50	31.20	55.78	-24.58	AVG	
3		0.1660	41.53	9.44	50.97	65.16	-14.19	peak	
4		0.2060	36.57	9.53	46.10	63.37	-17.27	peak	
5		0.3820	27.16	9.48	36.64	58.24	-21.60	peak	
6		0.4860	20.90	9.44	30.34	56.24	-25.90	peak	
7		11.8780	19.36	10.33	29.69	60.00	-30.31	peak	

ATTACHMENT B - RADIATED EMISSION (9KHZ TO 30MHZ)

Test Mode: TX Mode

Ant 0°

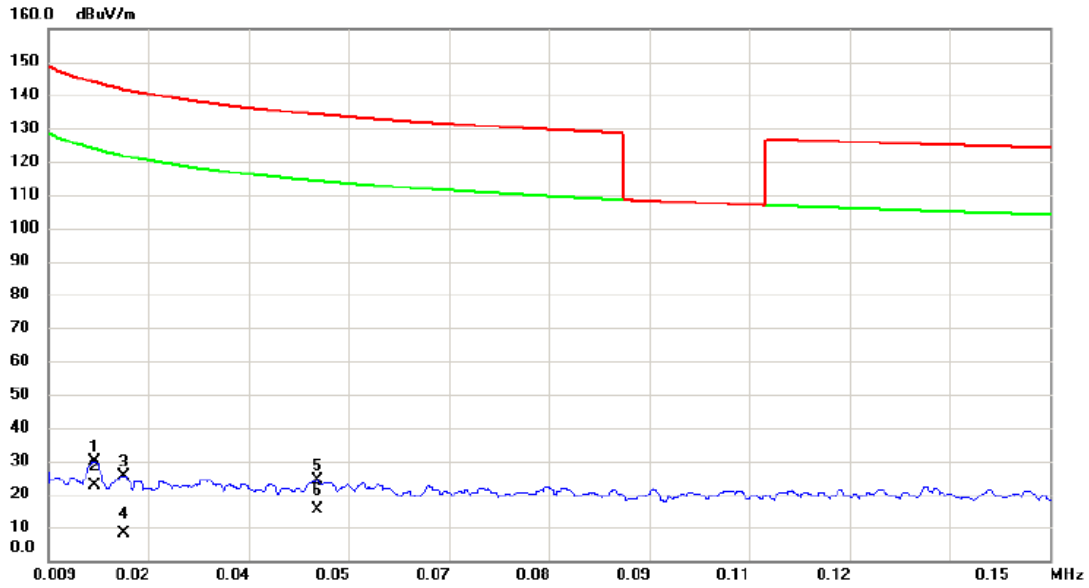

No.	Mk.	Freq. MHz	Reading Level dBuV	Correct Factor dB	Measure- ment dBuV/m	Limit dBuV/m	Margin dB	Detector	Comment
1		0.0155	8.46	21.40	29.86	143.80	-113.94	peak	
2		0.0155	1.20	21.40	22.60	123.80	-101.20	AVG	
3		0.0196	4.23	21.33	25.56	141.76	-116.20	peak	
4		0.0196	-13.10	21.33	8.23	121.76	-113.53	AVG	
5		0.0468	2.59	21.59	24.18	134.20	-110.02	peak	
6	*	0.0468	-6.20	21.59	15.39	114.20	-98.81	AVG	

Test Mode: TX Mode

Ant 0°

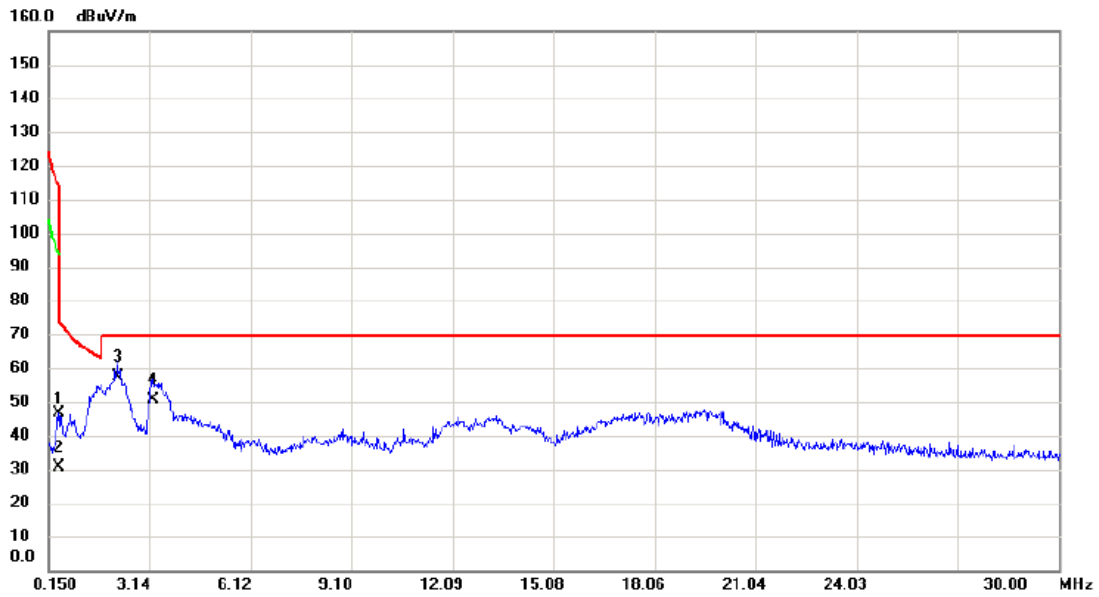

No.	Mk.	Freq. MHz	Reading Level dBuV	Correct Factor dB	Measure- ment dBuV/m	Limit dBuV/m	Margin dB	Detector	Comment
1		0.4485	25.55	20.98	46.53	114.57	-68.04	peak	
2		0.4485	9.80	20.98	30.78	94.57	-63.79	AVG	
3	*	2.1798	35.70	21.70	57.40	69.54	-12.14	QP	
4		3.2244	28.50	21.93	50.43	69.54	-19.11	QP	

Test Mode: TX Mode

Ant 90°

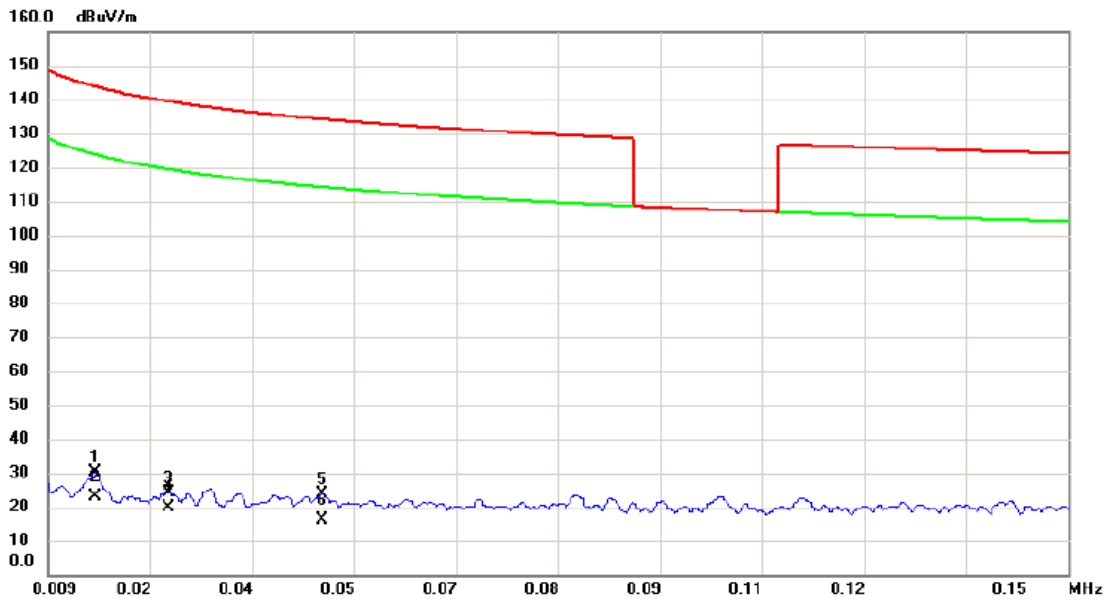

No.	Mk.	Freq. MHz	Reading Level dBuV	Correct Factor dB	Measure- ment dBuV/m	Limit dBuV/m	Margin dB	Detector	Comment
1		0.0154	8.72	21.40	30.12	143.85	-113.73	peak	
2		0.0154	1.70	21.40	23.10	123.85	-100.75	AVG	
3		0.0256	2.86	21.38	24.24	139.44	-115.20	peak	
4		0.0256	-1.40	21.38	19.98	119.44	-99.46	AVG	
5		0.0468	2.36	21.59	23.95	134.20	-110.25	peak	
6	*	0.0468	-5.50	21.59	16.09	114.20	-98.11	AVG	

Test Mode: TX Mode

Ant 90°

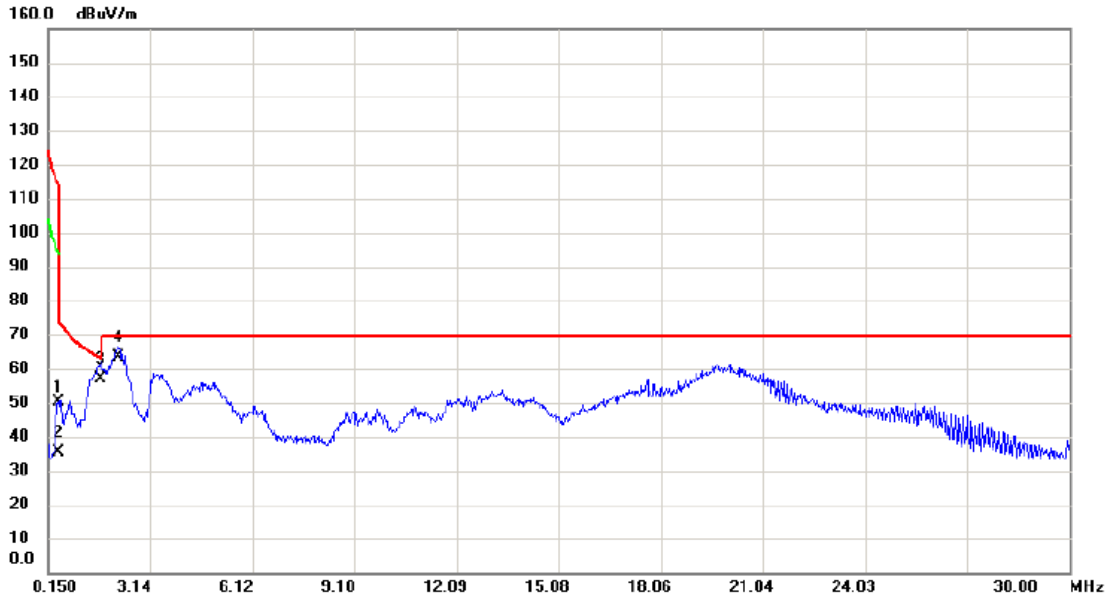

No.	Mk.	Freq. MHz	Reading Level dBuV	Correct Factor dB	Measure- ment dBuV/m	Limit dBuV/m	Margin dB	Detector	Comment
1		0.4485	29.12	20.98	50.10	114.57	-64.47	peak	
2		0.4485	14.30	20.98	35.28	94.57	-59.29	AVG	
3	*	1.6724	35.40	21.60	57.00	63.14	-6.14	QP	
4		2.1798	41.70	21.70	63.40	69.54	-6.14	QP	

ATTACHMENT C - RADIATED EMISSION (30MHZ TO 1000MHZ)

Test Mode: UNII-1/TX A Mode 5180MHz

Vertical

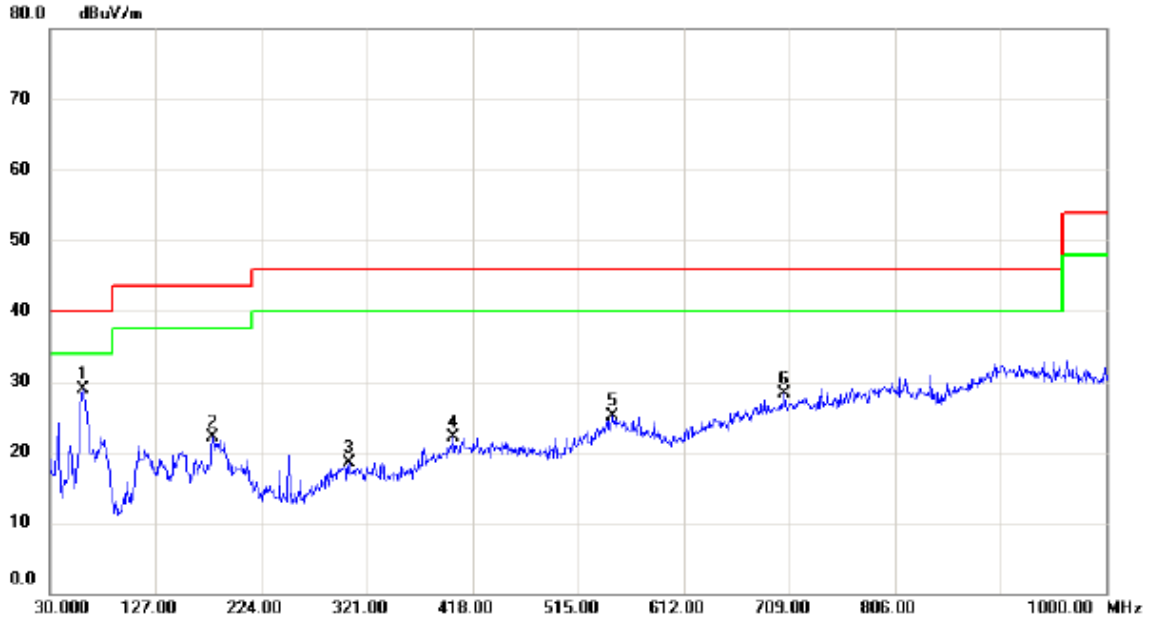

No.	Mk.	Freq. MHz	Reading Level dBuV	Correct Factor dB	Measure- ment dBuV/m	Limit dBuV/m	Margin dB	Detector	Comment
1	*	60.0700	42.71	-13.74	28.97	40.00	-11.03	peak	
2		179.3800	34.92	-12.80	22.12	43.50	-21.38	peak	
3		304.5100	28.77	-10.25	18.52	46.00	-27.48	peak	
4		400.5400	29.80	-7.78	22.02	46.00	-23.98	peak	
5		546.0400	30.06	-4.96	25.10	46.00	-20.90	peak	
6		704.1500	30.34	-2.09	28.25	46.00	-17.75	peak	

Test Mode: UNII-1/TX A Mode 5180MHz

Horizontal

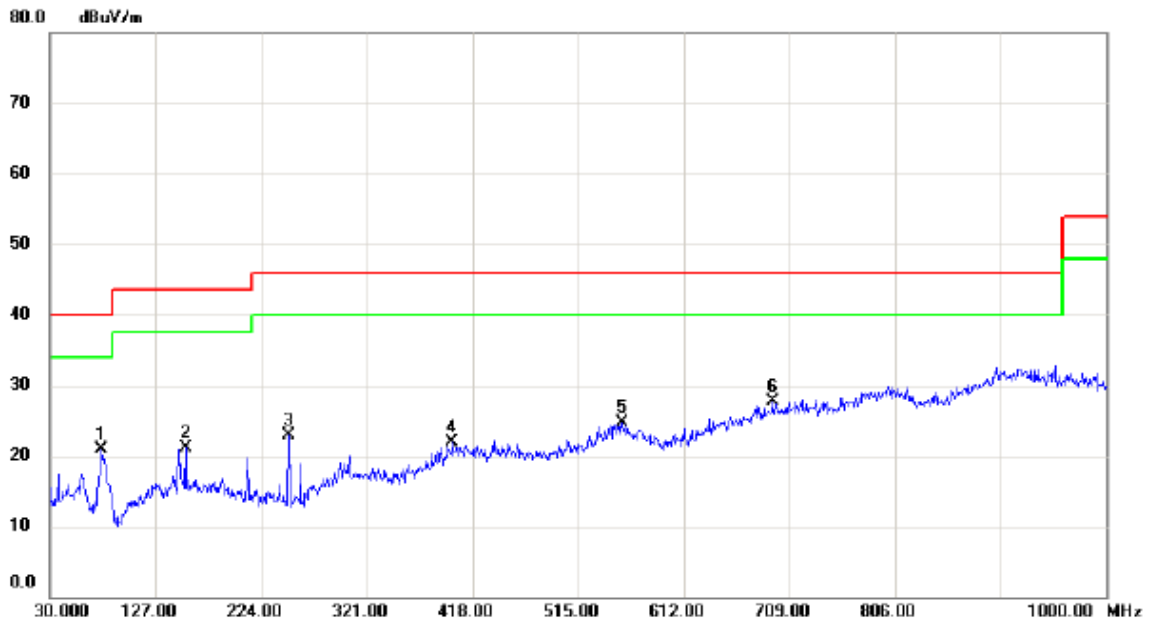

No.	Mk.	Freq. MHz	Reading Level dBuV	Correct Factor dB	Measure- ment dBuV/m	Limit dBuV/m	Margin dB	Detector	Comment
1		77.5300	37.20	-16.31	20.89	40.00	-19.11	peak	
2		154.1600	33.69	-12.61	21.08	43.50	-22.42	peak	
3		249.2200	37.10	-14.16	22.94	46.00	-23.06	peak	
4		399.5700	29.63	-7.81	21.82	46.00	-24.18	peak	
5		555.7400	29.48	-4.83	24.65	46.00	-21.35	peak	
6	*	693.4800	30.14	-2.37	27.77	46.00	-18.23	peak	

Test Mode: UNII-1/TX A Mode 5240MHz

Vertical

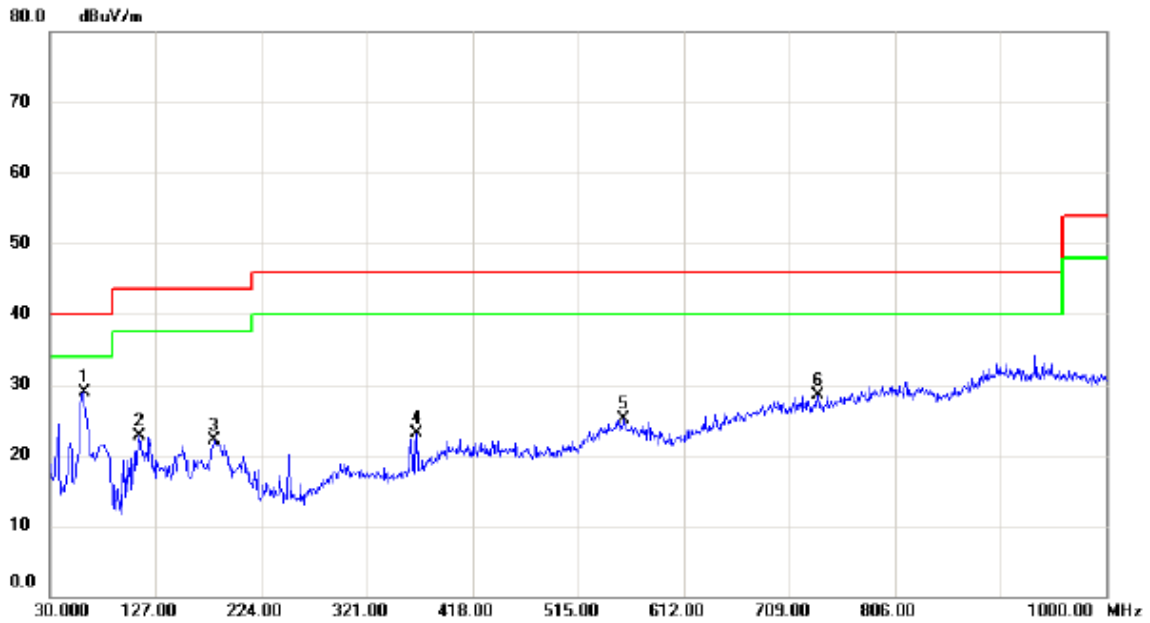

No.	Mk.	Freq. MHz	Reading Level dBuV	Correct Factor dB	Measure- ment dBuV/m	Limit dBuV/m	Margin dB	Detector	Comment
1	*	61.0400	42.99	-14.02	28.97	40.00	-11.03	peak	
2		112.4500	37.13	-14.36	22.77	43.50	-20.73	peak	
3		180.3500	34.99	-12.88	22.11	43.50	-21.39	peak	
4		366.5900	33.13	-10.08	23.05	46.00	-22.95	peak	
5		557.6800	30.06	-4.92	25.14	46.00	-20.86	peak	
6		735.1900	30.50	-2.01	28.49	46.00	-17.51	peak	

Test Mode: UNII-1/TX A Mode 5240MHz

Horizontal

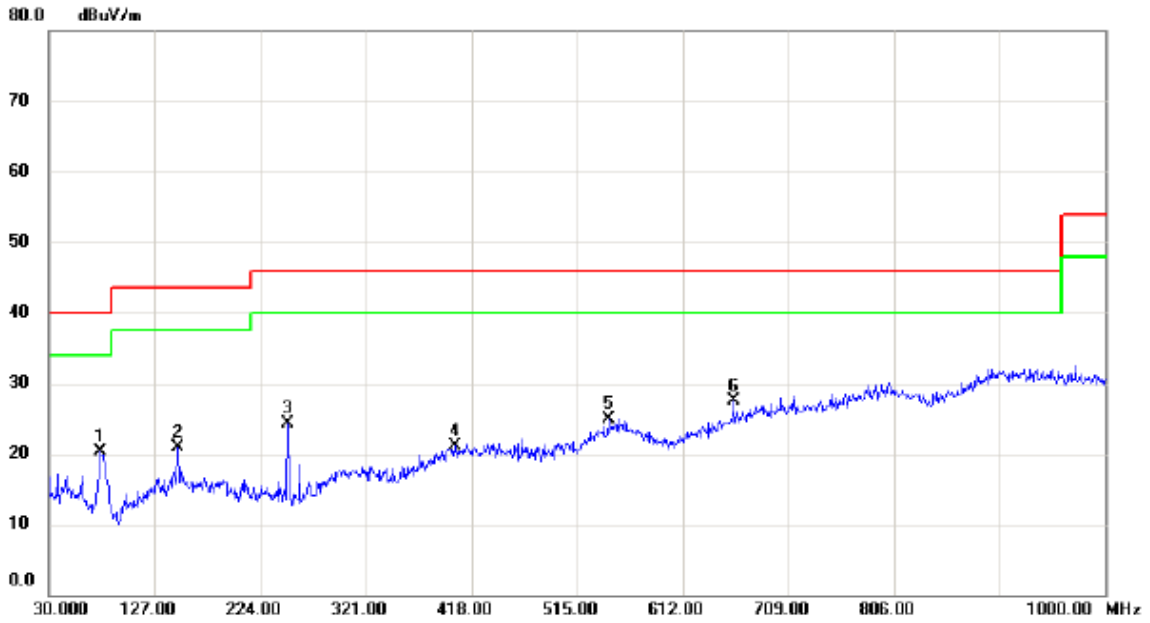

No.	Mk.	Freq. MHz	Reading Level dBuV	Correct Factor dB	Measure- ment dBuV/m	Limit dBuV/m	Margin dB	Detector	Comment
1		76.5600	36.74	-16.41	20.33	40.00	-19.67	peak	
2		148.3400	33.95	-13.09	20.86	43.50	-22.64	peak	
3		249.2200	38.46	-14.16	24.30	46.00	-21.70	peak	
4		402.4800	28.95	-7.80	21.15	46.00	-24.85	peak	
5		544.1000	30.11	-5.15	24.96	46.00	-21.04	peak	
6	*	658.5600	31.24	-3.82	27.42	46.00	-18.58	peak	

Test Mode: UNII-3/TX A Mode 5745MHz

Vertical

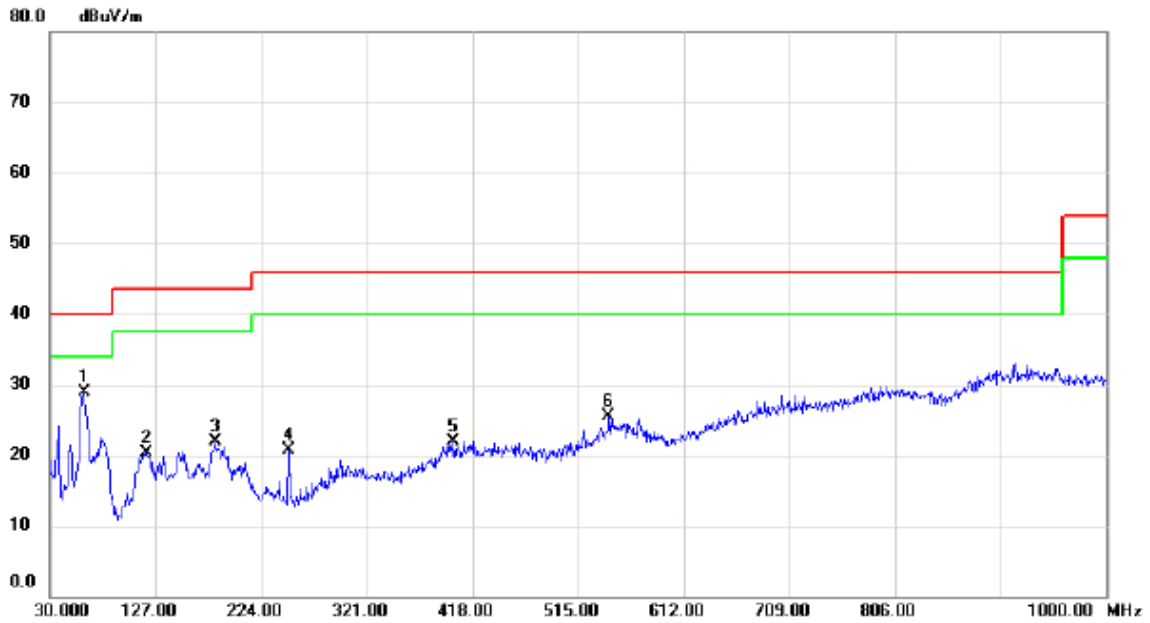

No.	Mk.	Freq. MHz	Reading Level dBuV	Correct Factor dB	Measure- ment dBuV/m	Limit dBuV/m	Margin dB	Detector	Comment
1	*	61.0400	42.90	-14.02	28.88	40.00	-11.12	peak	
2		118.2700	34.03	-13.67	20.36	43.50	-23.14	peak	
3		181.3200	34.85	-12.98	21.87	43.50	-21.63	peak	
4		249.2200	34.87	-14.16	20.71	46.00	-25.29	peak	
5		400.5400	29.66	-7.78	21.88	46.00	-24.12	peak	
6		543.1300	30.66	-5.25	25.41	46.00	-20.59	peak	

Test Mode: UNII-3/TX A Mode 5745MHz

Horizontal

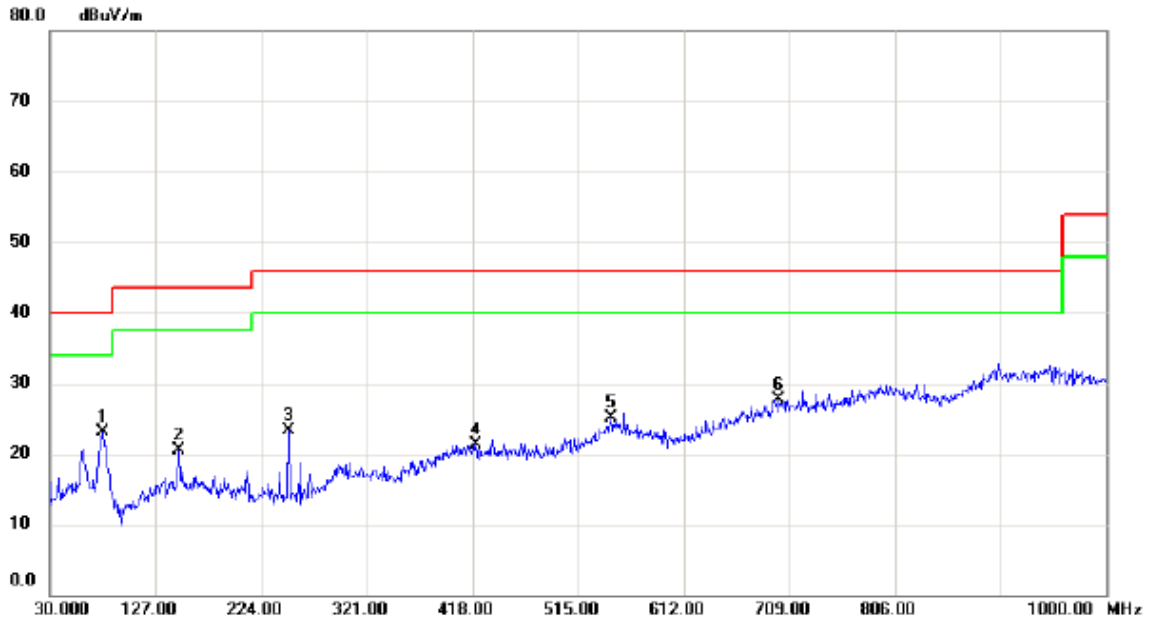

No.	Mk.	Freq. MHz	Reading Level dBuV	Correct Factor dB	Measure- ment dBuV/m	Limit dBuV/m	Margin dB	Detector	Comment
1	*	78.5000	39.25	-16.21	23.04	40.00	-16.96	peak	
2		148.3400	33.66	-13.09	20.57	43.50	-22.93	peak	
3		249.2200	37.40	-14.16	23.24	46.00	-22.76	peak	
4		420.9100	29.14	-7.87	21.27	46.00	-24.73	peak	
5		545.0700	30.21	-5.04	25.17	46.00	-20.83	peak	
6		699.3000	29.79	-2.13	27.66	46.00	-18.34	peak	

Test Mode: UNII-3/TX A Mode 5825MHz

Vertical

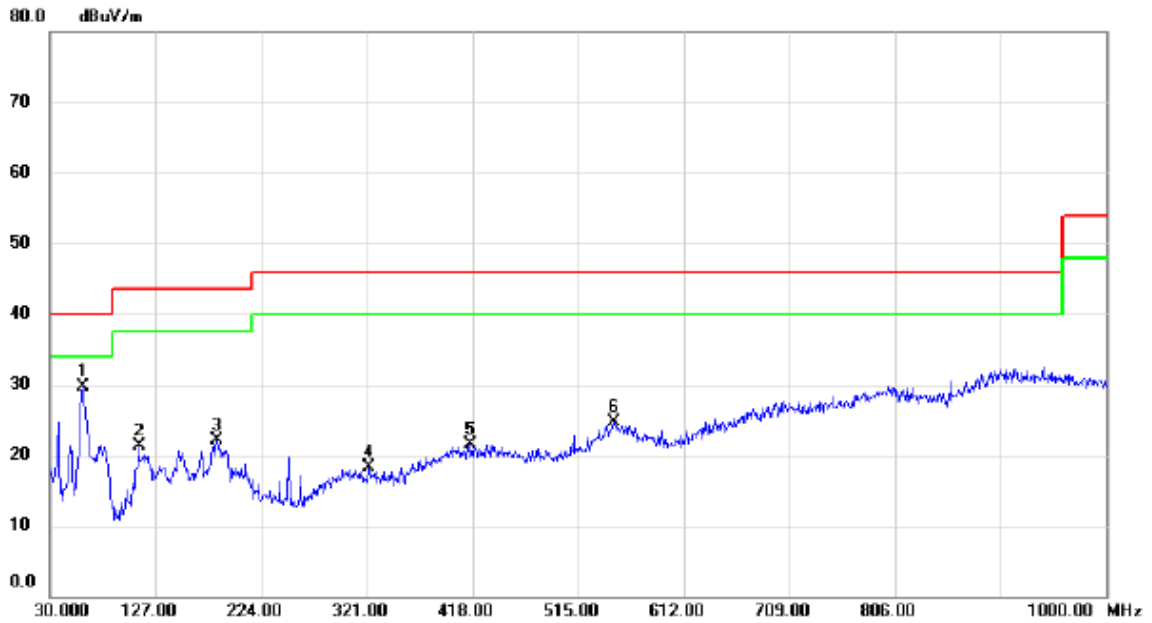

No.	Mk.	Freq. MHz	Reading Level dBuV	Correct Factor dB	Measure- ment dBuV/m	Limit dBuV/m	Margin dB	Detector	Comment
1	*	60.0700	43.54	-13.74	29.80	40.00	-10.20	peak	
2		111.4800	35.76	-14.48	21.28	43.50	-22.22	peak	
3		183.2600	35.23	-13.20	22.03	43.50	-21.47	peak	
4		322.9400	29.01	-10.65	18.36	46.00	-27.64	peak	
5		416.0600	29.40	-7.85	21.55	46.00	-24.45	peak	
6		547.9800	29.41	-4.75	24.66	46.00	-21.34	peak	

Test Mode: UNII-3/TX A Mode 5825MHz

Horizontal

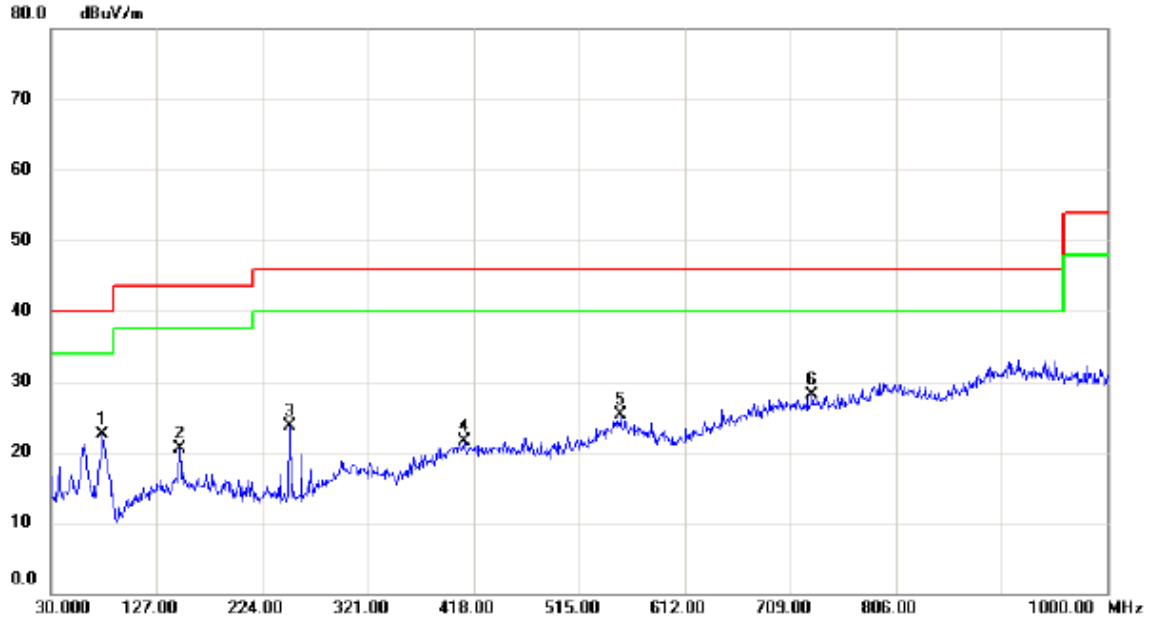

No.	Mk.	Freq. MHz	Reading Level dBuV	Correct Factor dB	Measure- ment dBuV/m	Limit dBuV/m	Margin dB	Detector	Comment
1	*	77.5300	38.75	-16.31	22.44	40.00	-17.56	peak	
2		148.3400	33.64	-13.09	20.55	43.50	-22.95	peak	
3		249.2200	37.81	-14.16	23.65	46.00	-22.35	peak	
4		409.2700	29.35	-7.83	21.52	46.00	-24.48	peak	
5		553.8000	30.06	-4.73	25.33	46.00	-20.67	peak	
6		729.3700	30.22	-2.03	28.19	46.00	-17.81	peak	

ATTACHMENT D - RADIATED EMISSION (ABOVE 1000MHZ)

Orthogonal Axis:	X
Test Mode:	UNII-1/ TX A Mode 5180MHz

Vertical

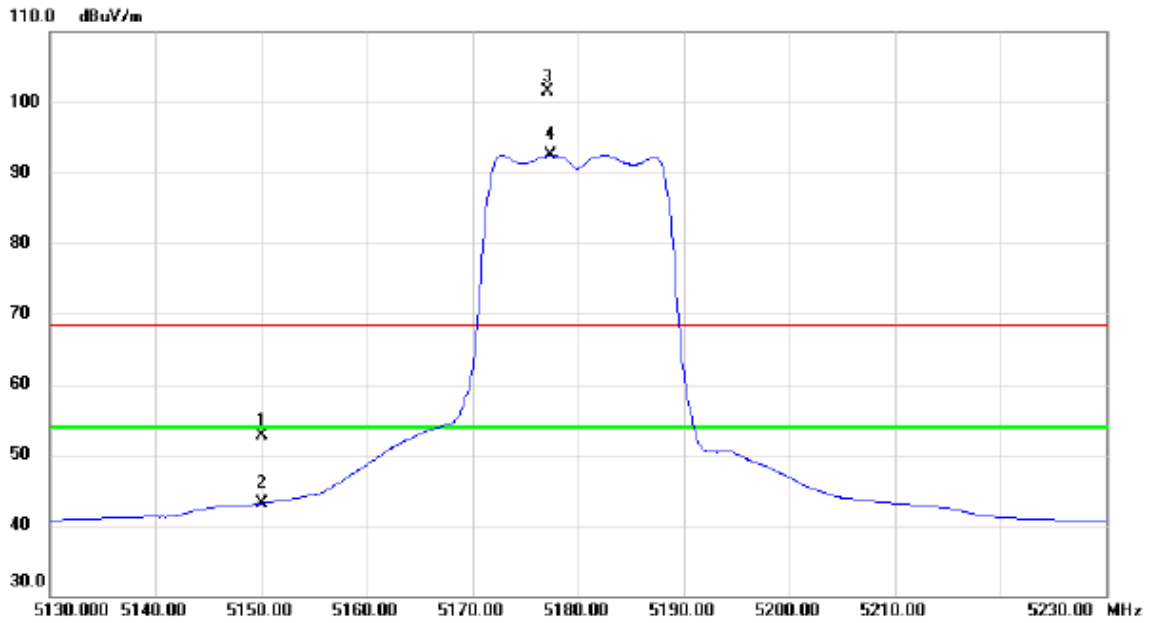

No.	Mk.	Freq. MHz	Reading Level dBuV	Correct Factor dB	Measure- ment dBuV/m	Limit dBuV/m	Margin dB	Detector	Comment
1		5150.000	11.98	40.63	52.61	68.30	-15.69	peak	
2		5150.000	2.49	40.63	43.12	54.00	-10.88	AVG	
3	X	5177.100	60.86	40.72	101.58	68.30	33.28	peak	No Limit
4	*	5177.400	51.83	40.72	92.55	54.00	38.55	AVG	No Limit

Orthogonal Axis:	X
Test Mode:	UNII-1/ TX A Mode 5180MHz

Vertical

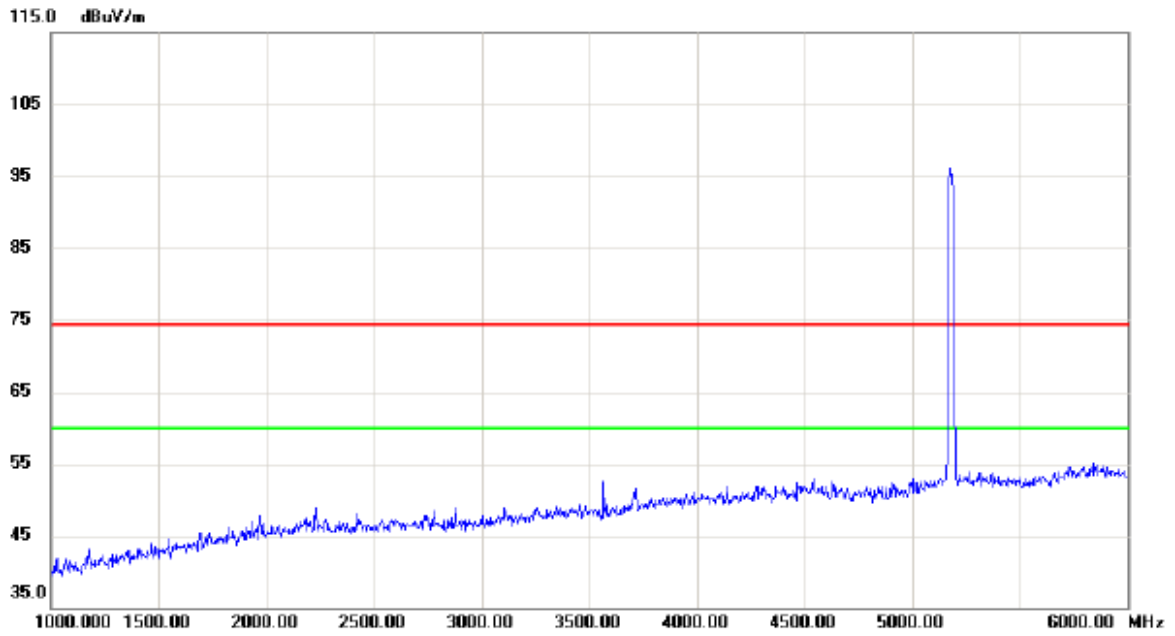

No.	Mk.	Freq.	Reading Level	Correct Factor	Measurement	Limit	Margin	Detector	Comment
		MHz	dBuV	dB	dBuV/m	dBuV/m	dB		

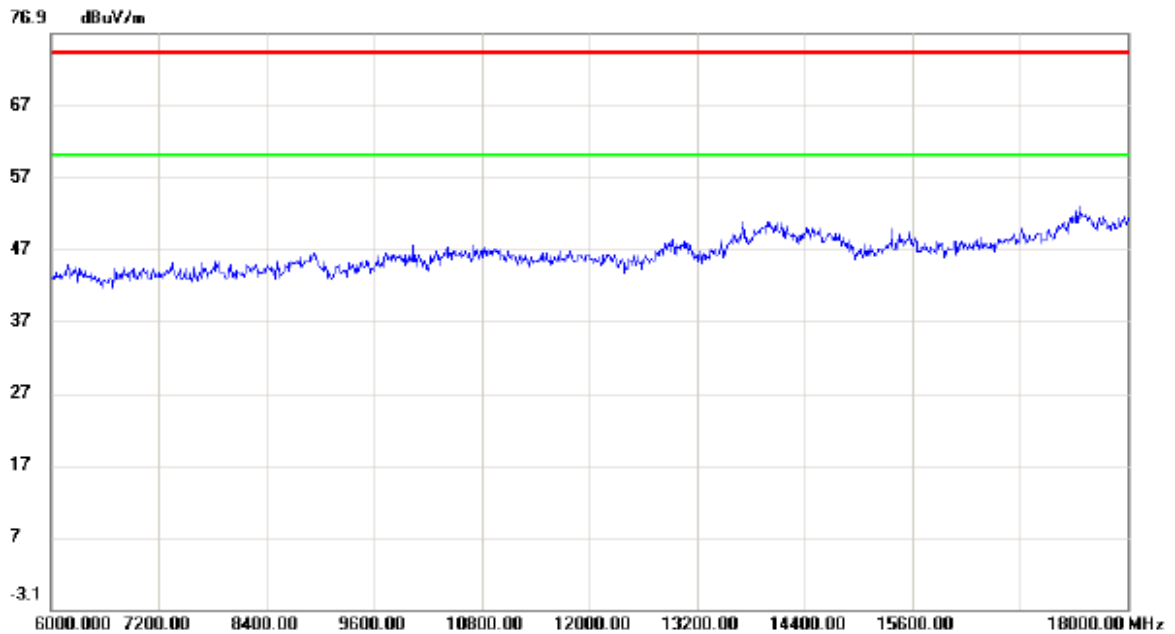

No.	Mk.	Freq.	Reading Level	Correct Factor	Measurement	Limit	Margin	Detector	Comment
		MHz	dBuV	dB	dBuV/m	dBuV/m	dB		

Orthogonal Axis:	X
Test Mode:	UNII-1/ TX A Mode 5180MHz

Vertical

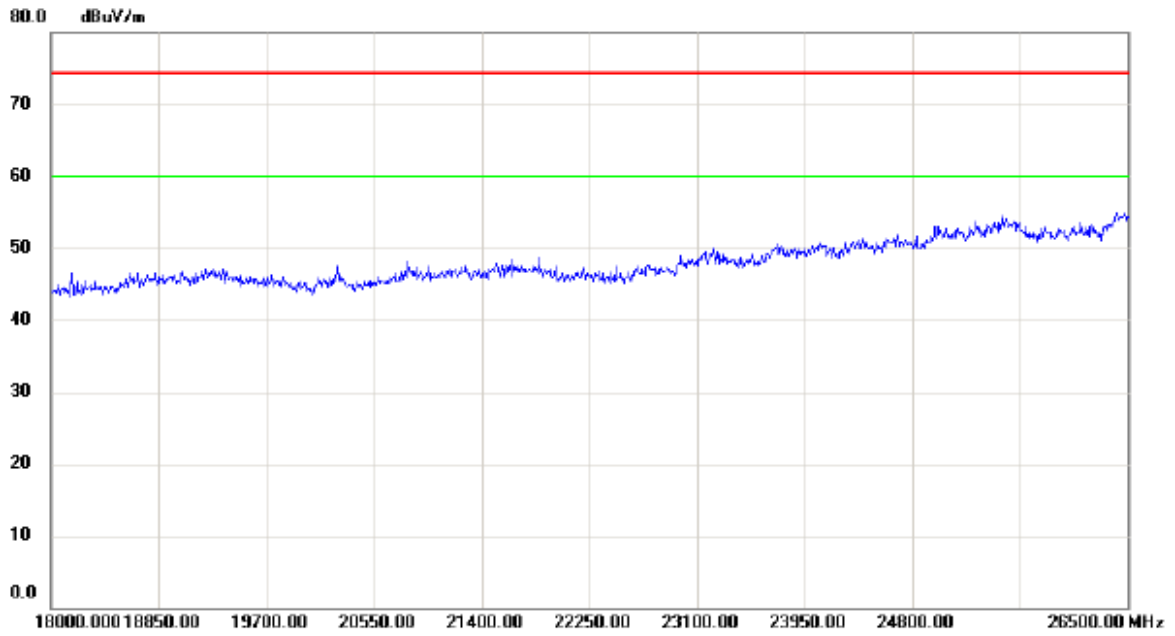

No.	Mk.	Freq.	Reading Level	Correct Factor	Measurement	Limit	Margin	Detector	Comment
		MHz	dBuV	dB	dBuV/m	dBuV/m	dB		

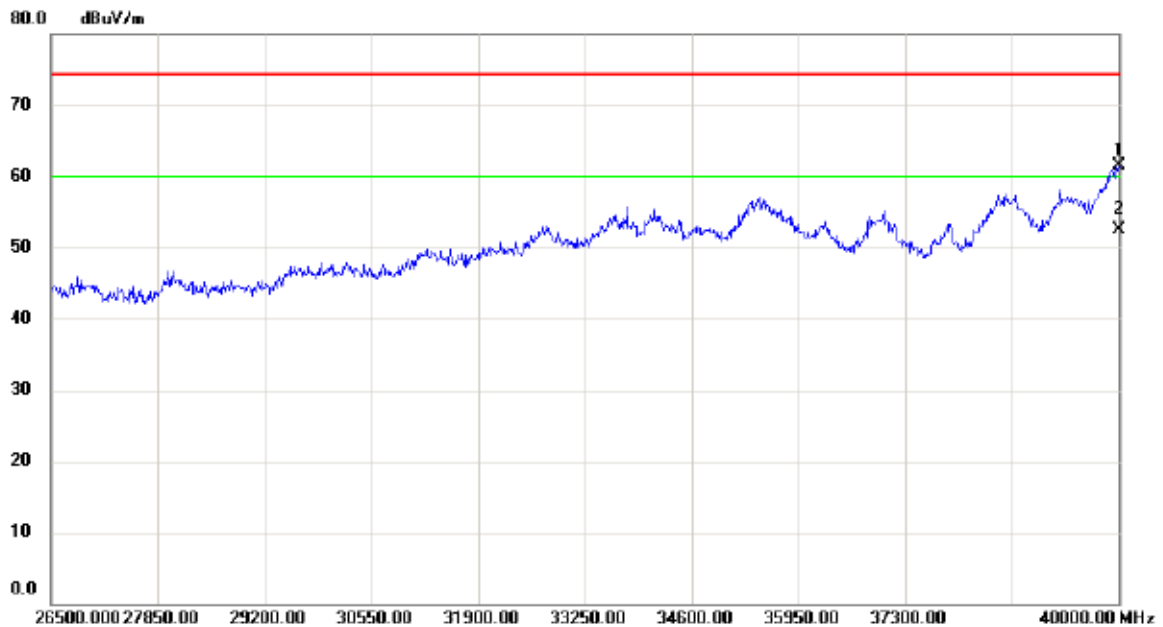

No.	Mk.	Freq.	Reading Level	Correct Factor	Measurement	Limit	Margin	Detector	Comment
		MHz	dBuV	dB	dBuV/m	dBuV/m	dB		
1		40000.00	45.64	15.89	61.53	74.30	-12.77	peak	
2	*	40000.00	36.62	15.89	52.51	60.00	-7.49	AVG	

Orthogonal Axis:	X
Test Mode:	UNII-1/ TX A Mode 5180MHz

Horizontal

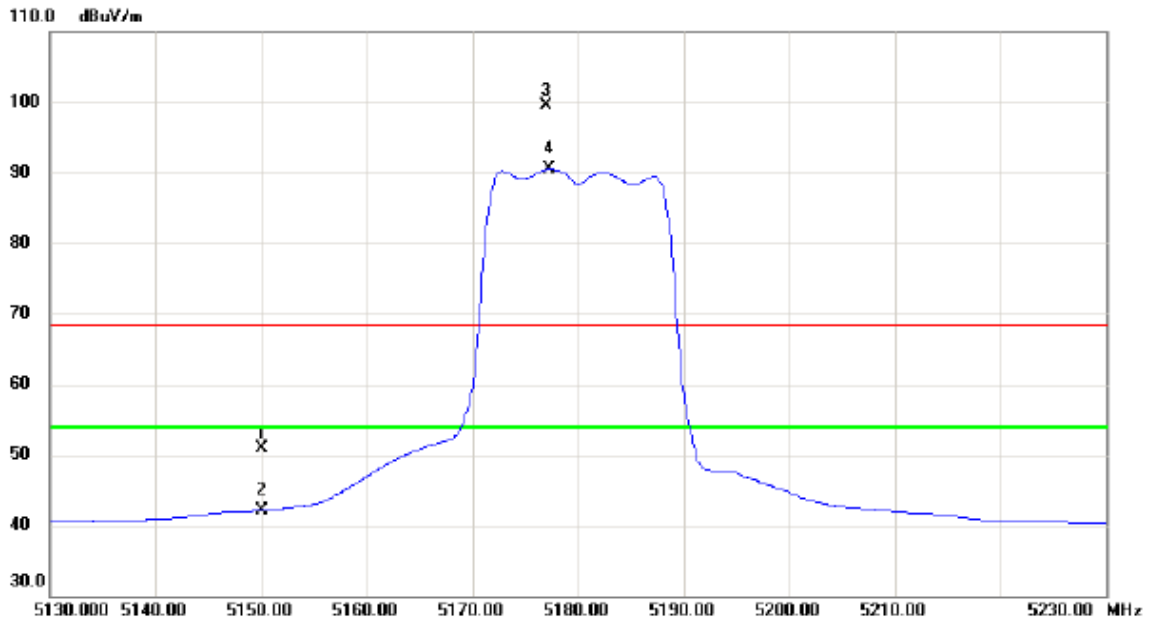

No.	Mk.	Freq.	Reading Level	Correct Factor	Measurement	Limit	Margin	Detector	Comment
		MHz	dBuV	dB	dBuV/m	dBuV/m	dB		
1		5150.000	10.30	40.63	50.93	68.30	-17.37	peak	
2		5150.000	1.48	40.63	42.11	54.00	-11.89	AVG	
3	X	5177.000	58.70	40.71	99.41	68.30	31.11	peak	No Limit
4	*	5177.300	49.73	40.72	90.45	54.00	36.45	AVG	No Limit

Orthogonal Axis:	X
Test Mode:	UNII-1/ TX A Mode 5180MHz

Horizontal

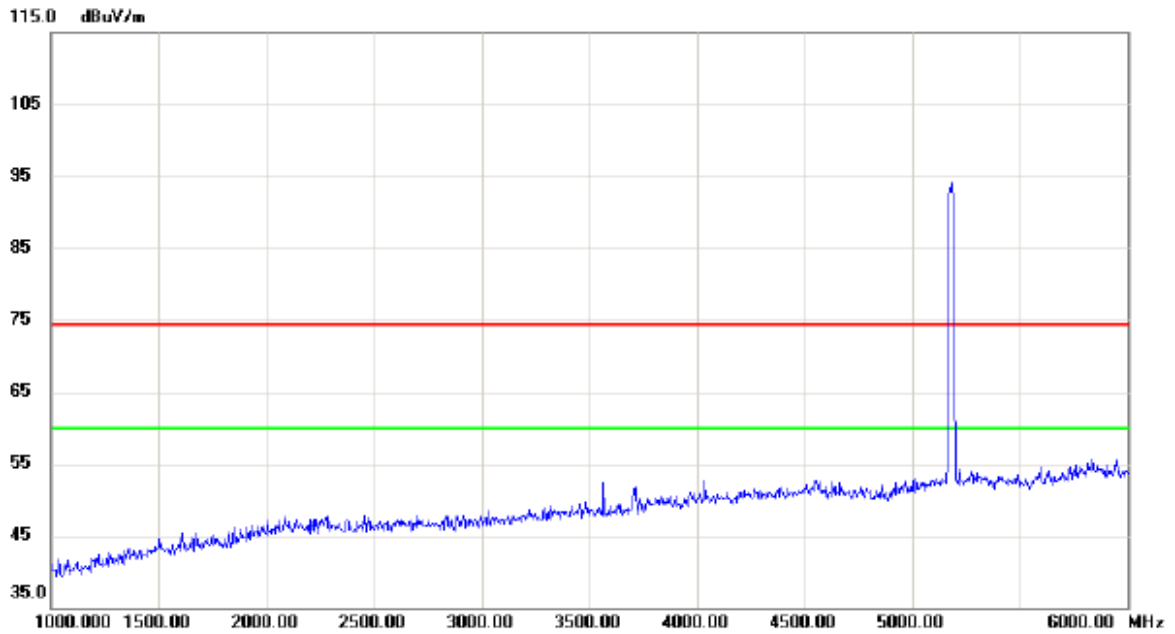

No.	Mk.	Freq.	Reading Level	Correct Factor	Measurement	Limit	Margin	Detector	Comment
		MHz	dBuV	dB	dBuV/m	dBuV/m	dB		

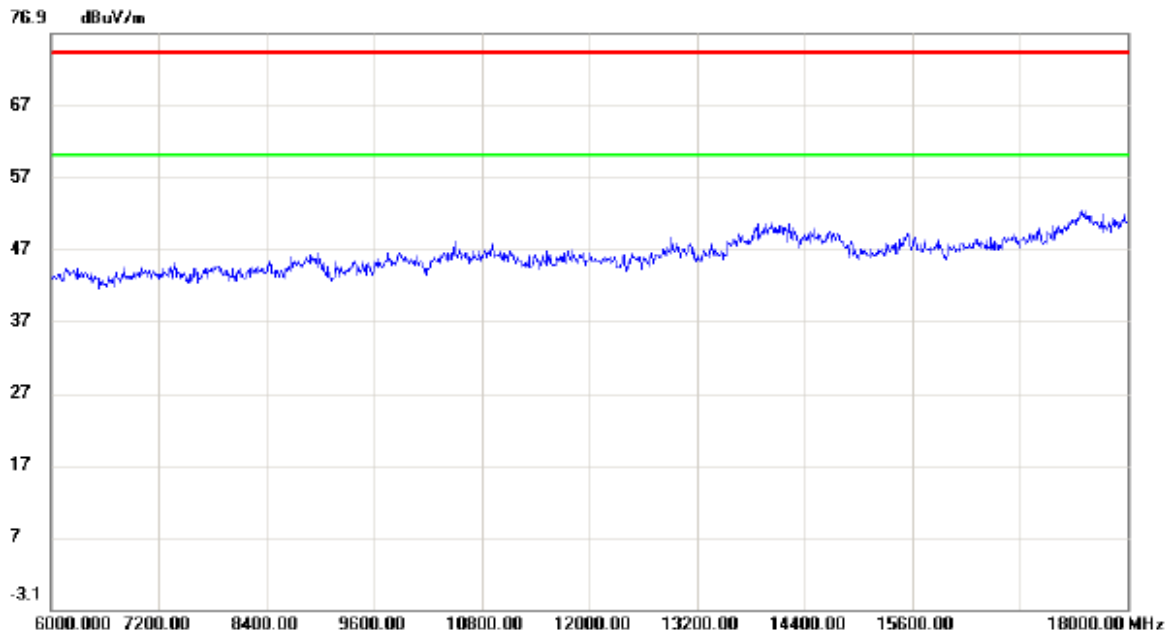

No.	Mk.	Freq.	Reading Level	Correct Factor	Measurement	Limit	Margin	Detector	Comment
		MHz	dBuV	dB	dBuV/m	dBuV/m	dB		

Orthogonal Axis:	X
Test Mode:	UNII-1/ TX A Mode 5180MHz

Horizontal

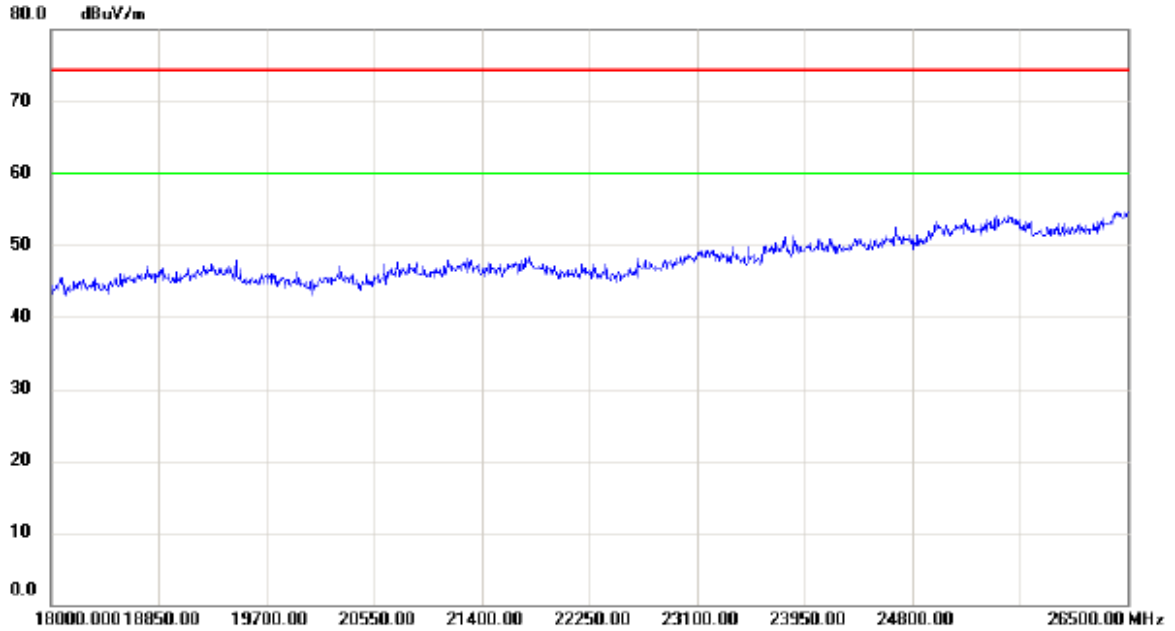

No.	Mk.	Freq.	Reading Level	Correct Factor	Measurement	Limit	Margin	Detector	Comment
		MHz	dBuV	dB	dBuV/m	dBuV/m	dB		

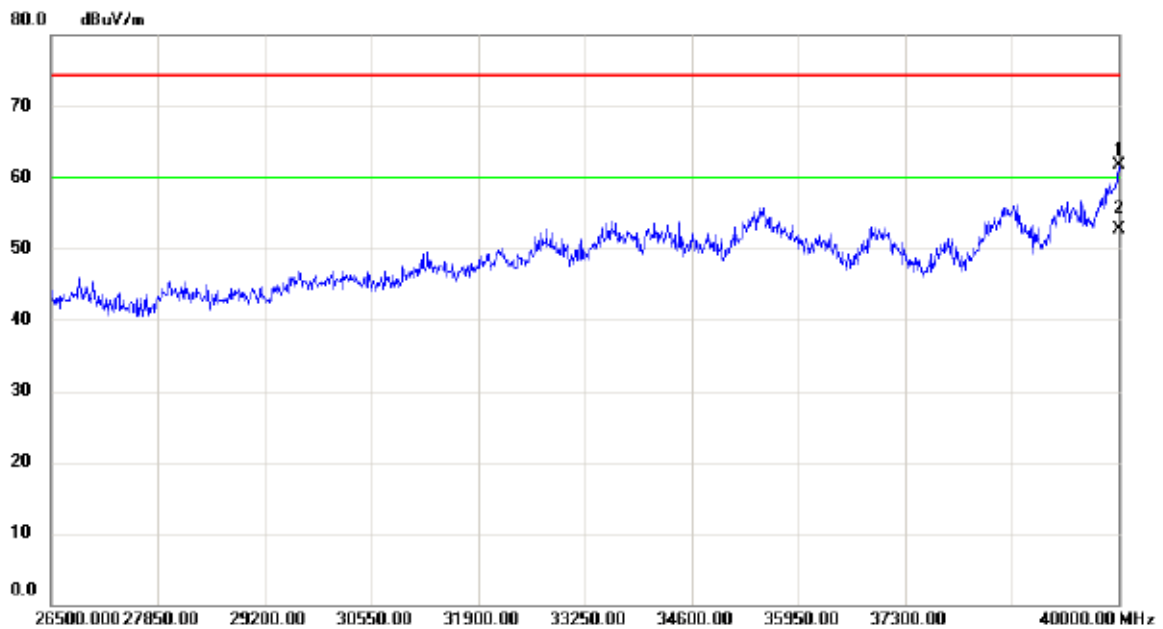

No.	Mk.	Freq.	Reading Level	Correct Factor	Measurement	Limit	Margin	Detector	Comment
		MHz	dBuV	dB	dBuV/m	dBuV/m	dB		
1		40000.00	45.88	15.89	61.77	74.30	-12.53	peak	
2	*	40000.00	36.82	15.89	52.71	60.00	-7.29	AVG	

Orthogonal Axis:	X
Test Mode:	UNII-1/ TX A Mode 5240MHz

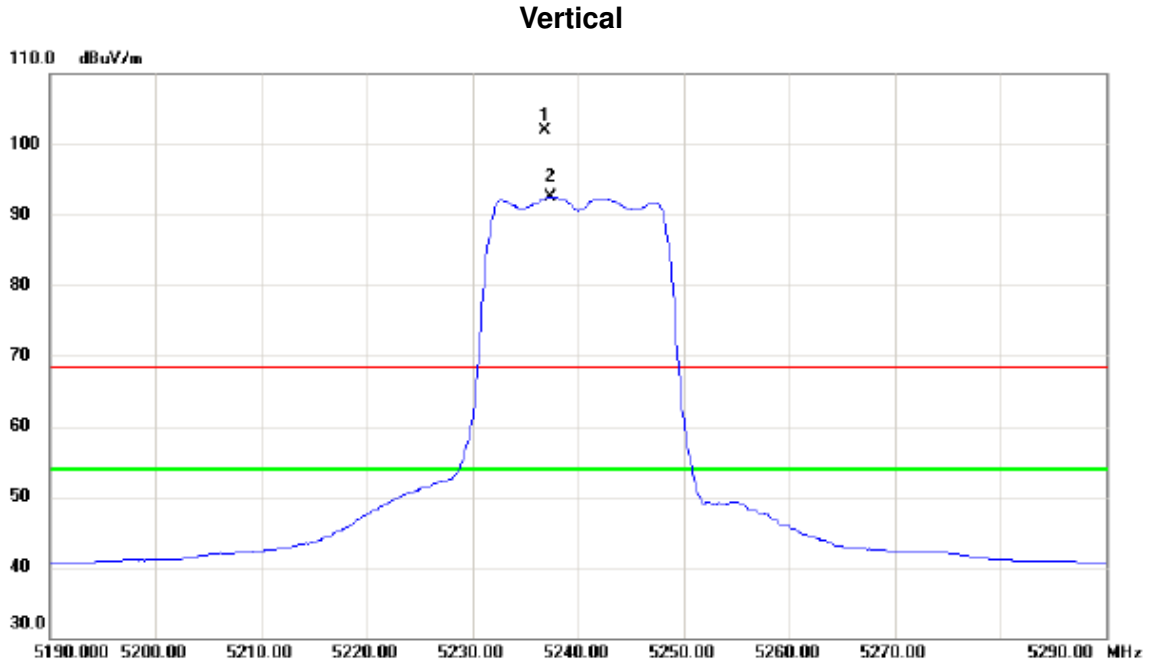

No.	Mk.	Freq. MHz	Reading Level dBuV	Correct Factor dB	Measure- ment dBuV/m	Limit dBuV/m	Margin dB	Detector	Comment
1	X	5236.900	61.05	40.91	101.96	68.30	33.66	peak	No Limit
2	*	5237.400	51.64	40.91	92.55	54.00	38.55	AVG	No Limit

Orthogonal Axis:	X
Test Mode:	UNII-1/ TX A Mode 5240MHz

Vertical

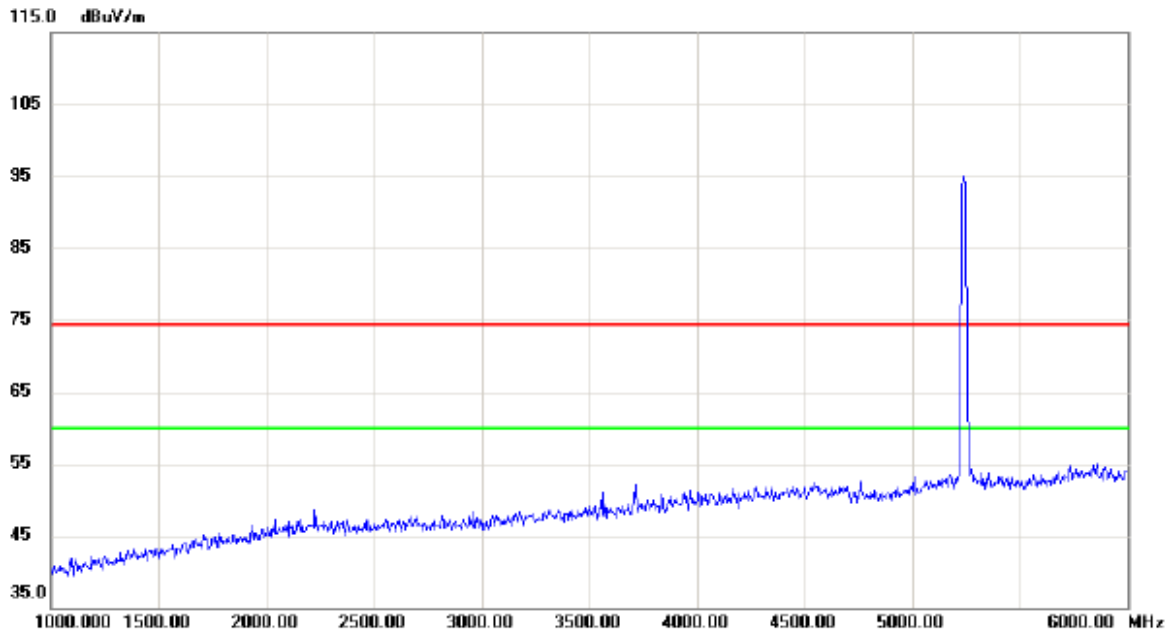

No.	Mk.	Freq.	Reading Level	Correct Factor	Measurement	Limit	Margin	Detector	Comment
		MHz	dBuV	dB	dBuV/m	dBuV/m	dB		

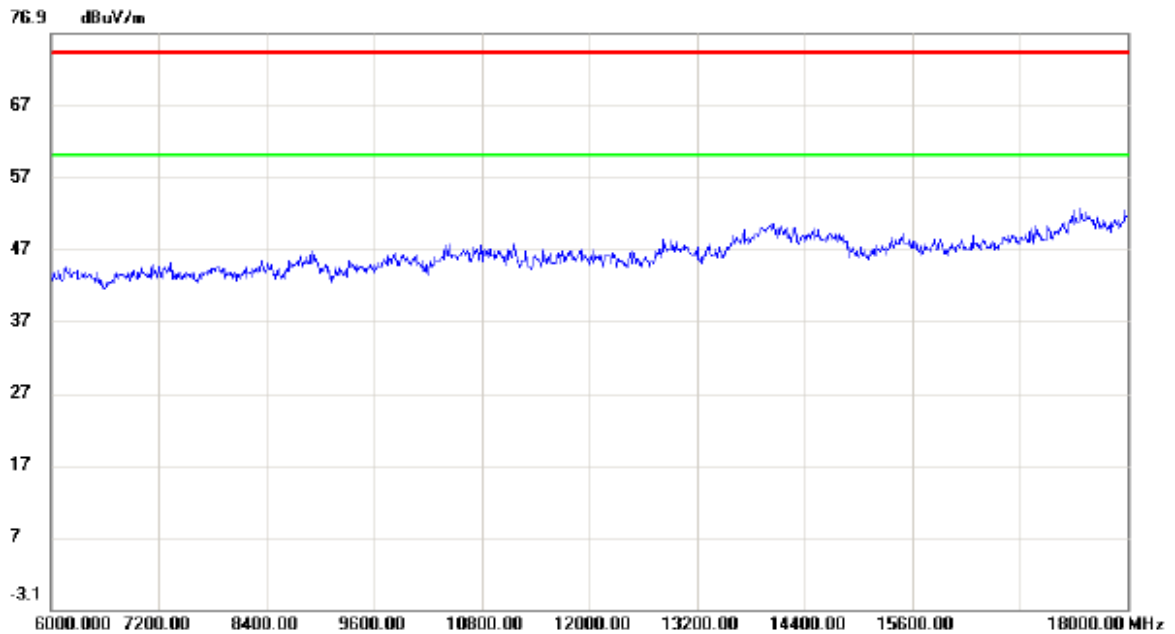

No.	Mk.	Freq.	Reading Level	Correct Factor	Measurement	Limit	Margin	Detector	Comment
		MHz	dBuV	dB	dBuV/m	dBuV/m	dB		

Orthogonal Axis:	X
Test Mode:	UNII-1/ TX A Mode 5240MHz

Vertical

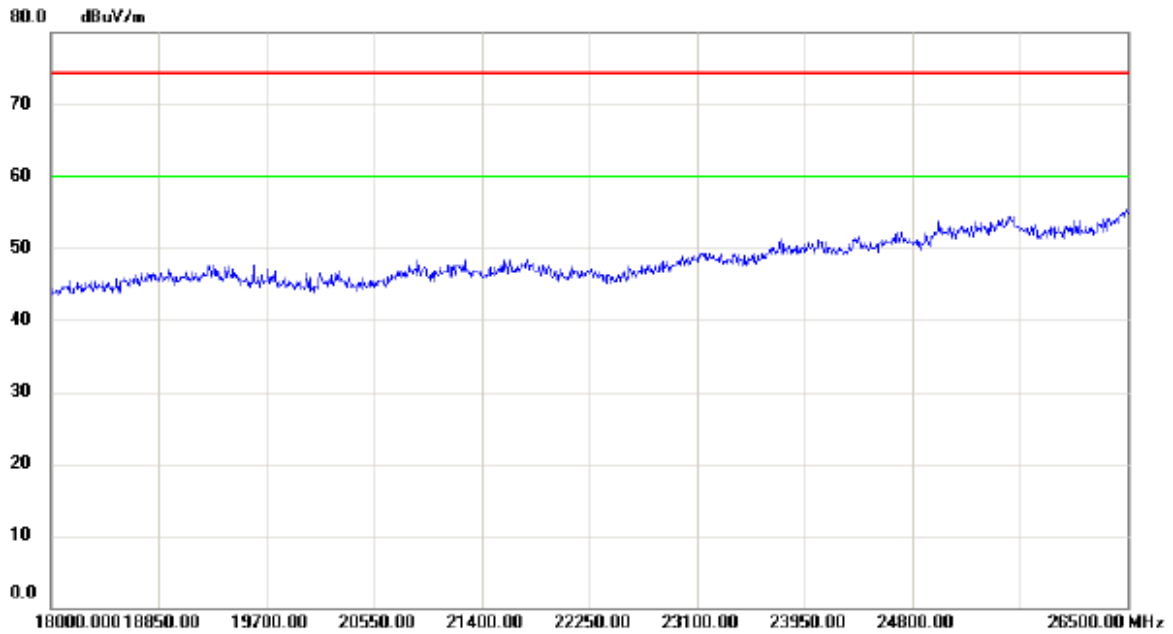

No.	Mk.	Freq.	Reading Level	Correct Factor	Measurement	Limit	Margin	Detector	Comment
		MHz	dBuV	dB	dBuV/m	dBuV/m	dB		

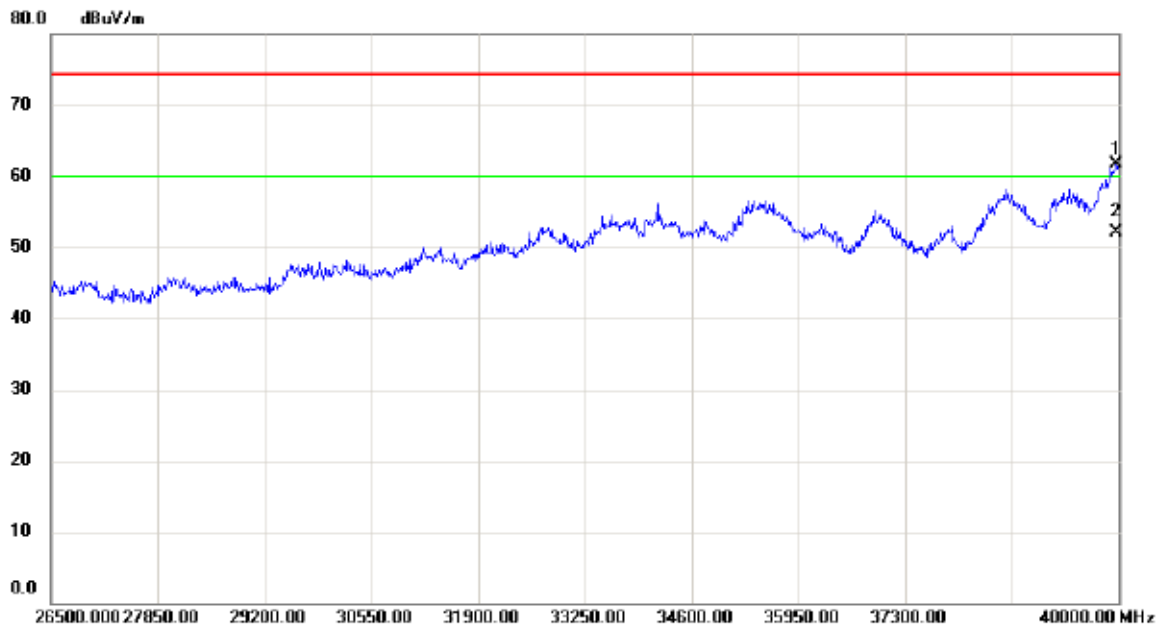

No.	Mk.	Freq.	Reading Level	Correct Factor	Measurement	Limit	Margin	Detector	Comment
		MHz	dBuV	dB	dBuV/m	dBuV/m	dB		
1		39973.00	45.87	15.84	61.71	74.30	-12.59	peak	
2	*	39973.28	36.21	15.84	52.05	60.00	-7.95	AVG	

Orthogonal Axis:	X
Test Mode:	UNII-1/ TX A Mode 5240MHz

Horizontal

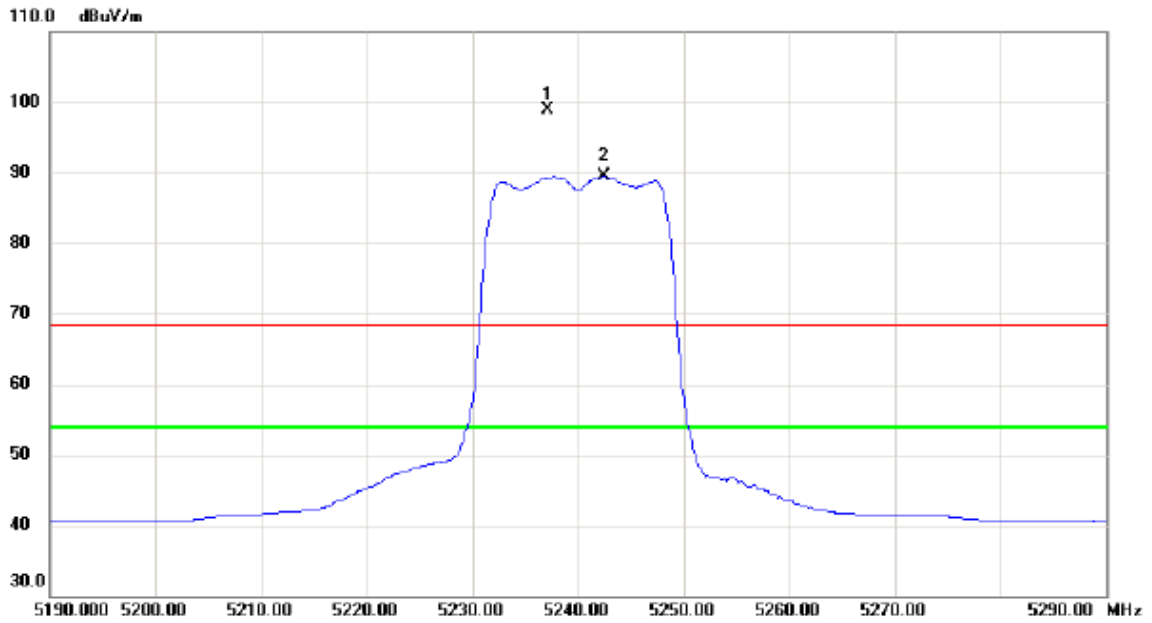

No.	Mk.	Freq.	Reading Level	Correct Factor	Measurement	Limit	Margin	Detector	Comment
		MHz	dBuV	dB	dBuV/m	dBuV/m	dB		
1	X	5237.100	57.92	40.91	98.83	68.30	30.53	peak	No Limit
2	*	5242.500	48.53	40.93	89.46	54.00	35.46	AVG	No Limit

Orthogonal Axis:	X
Test Mode:	UNII-1/ TX A Mode 5240MHz

Horizontal

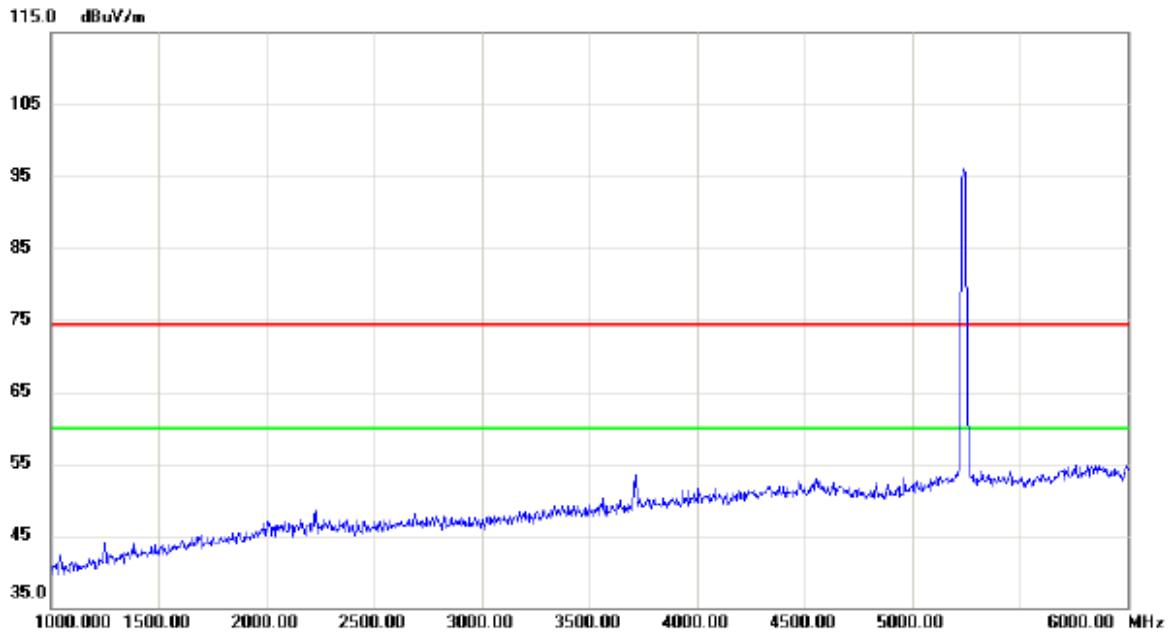

No.	Mk.	Freq.	Reading Level	Correct Factor	Measurement	Limit	Margin	Detector	Comment
		MHz	dBuV	dB	dBuV/m	dBuV/m	dB		

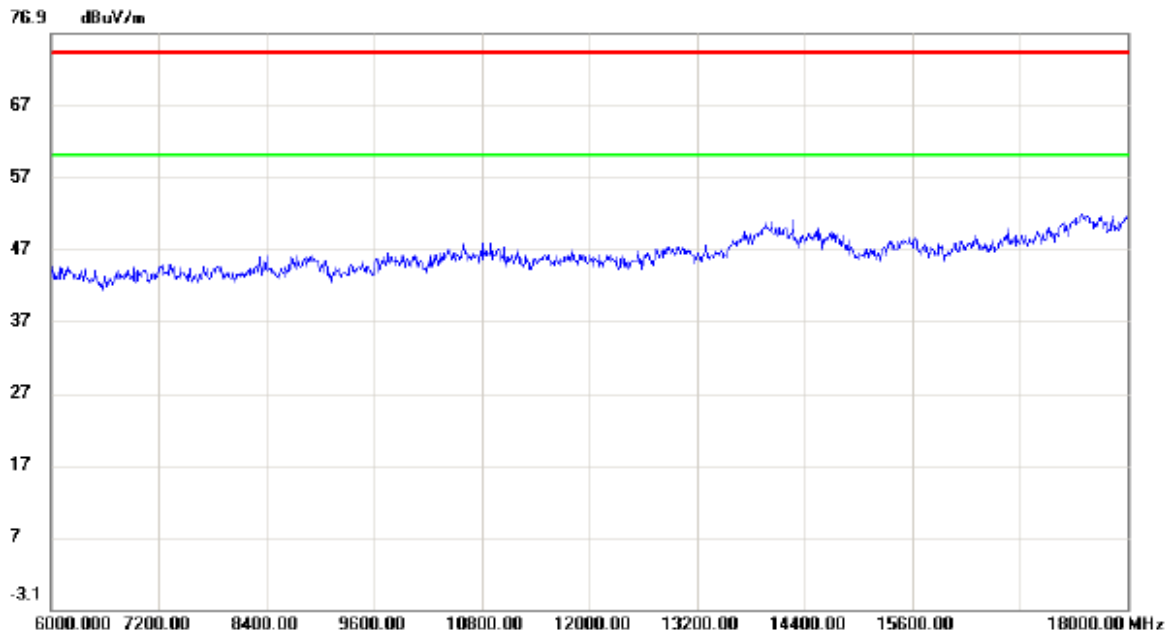

No.	Mk.	Freq.	Reading Level	Correct Factor	Measurement	Limit	Margin	Detector	Comment
		MHz	dBuV	dB	dBuV/m	dBuV/m	dB		

Orthogonal Axis:	X
Test Mode:	UNII-1/ TX A Mode 5240MHz

Horizontal

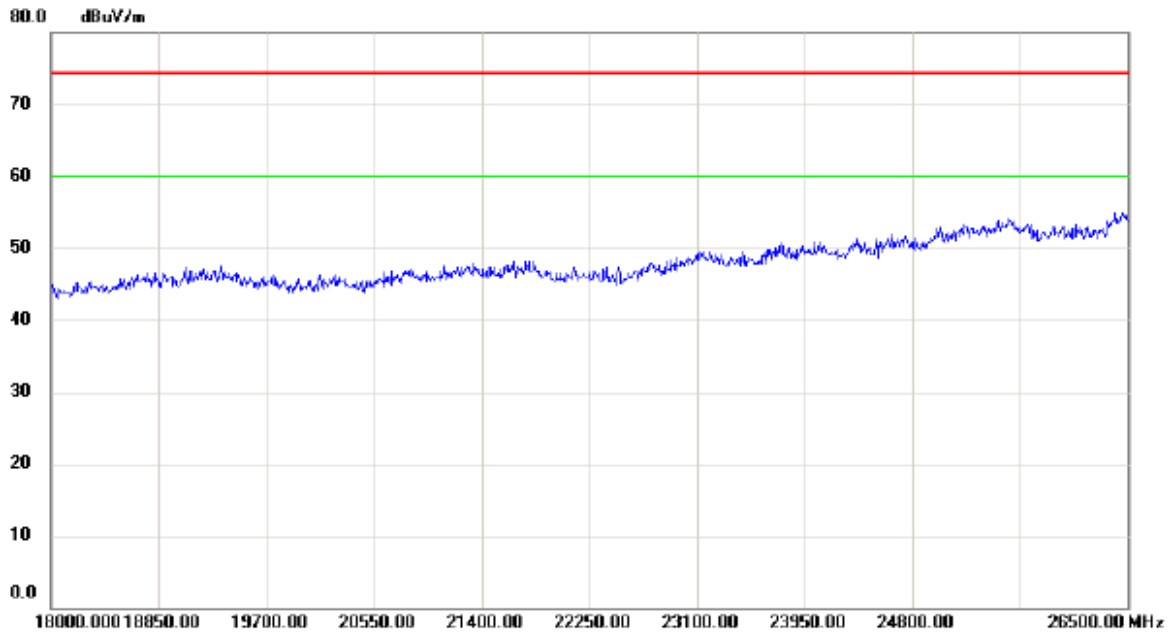

No.	Mk.	Freq.	Reading Level	Correct Factor	Measurement	Limit	Margin	Detector	Comment
		MHz	dBuV	dB	dBuV/m	dBuV/m	dB		

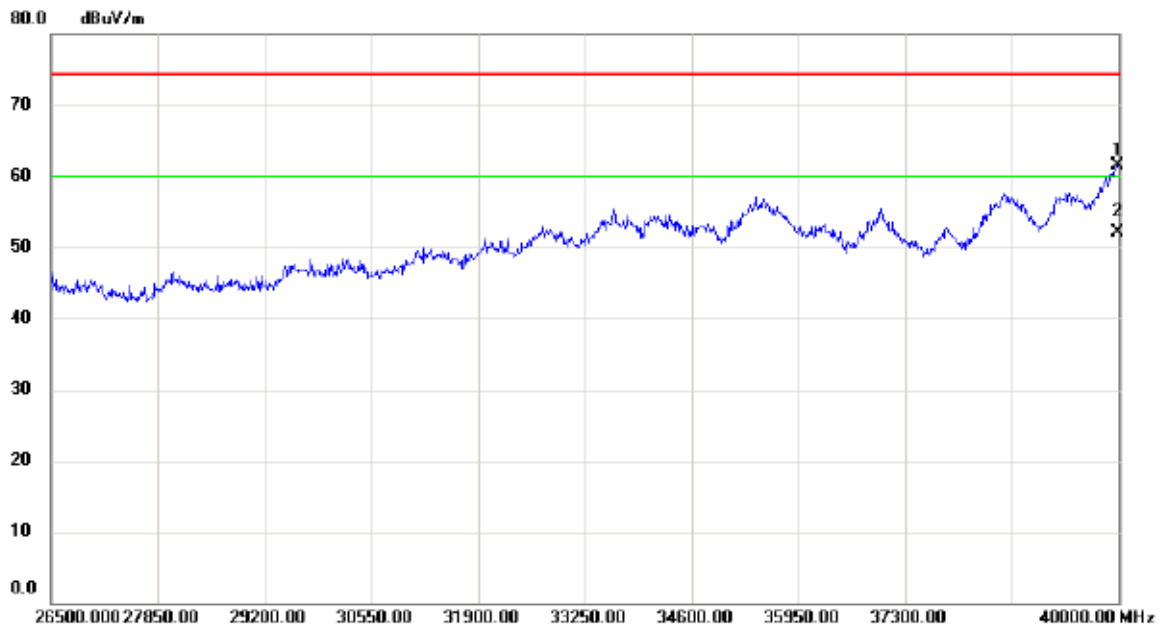

No.	Mk.	Freq.	Reading Level	Correct Factor	Measurement	Limit	Margin	Detector	Comment
		MHz	dBuV	dB	dBuV/m	dBuV/m	dB		
1		39986.50	45.70	15.86	61.56	74.30	-12.74	peak	
2	*	39986.50	36.28	15.86	52.14	60.00	-7.86	AVG	

Orthogonal Axis:	X
Test Mode:	UNII-1/ TX N20 Mode 5180MHz

Vertical

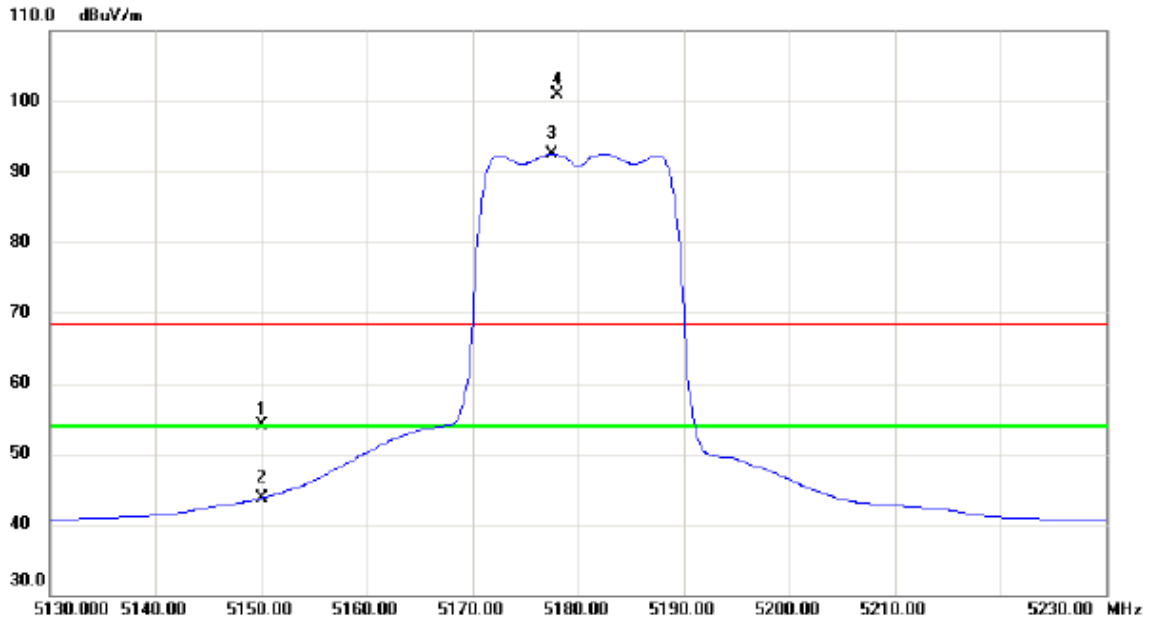

No.	Mk.	Freq. MHz	Reading Level dBuV	Correct Factor dB	Measure- ment dBuV/m	Limit dBuV/m	Margin dB	Detector	Comment
1		5150.000	13.54	40.63	54.17	68.30	-14.13	peak	
2		5150.000	3.13	40.63	43.76	54.00	-10.24	AVG	
3	*	5177.500	51.79	40.72	92.51	54.00	38.51	AVG	No Limit
4	X	5178.100	60.20	40.72	100.92	68.30	32.62	peak	No Limit

Orthogonal Axis:	X
Test Mode:	UNII-1/ TX N20 Mode 5180MHz

Vertical

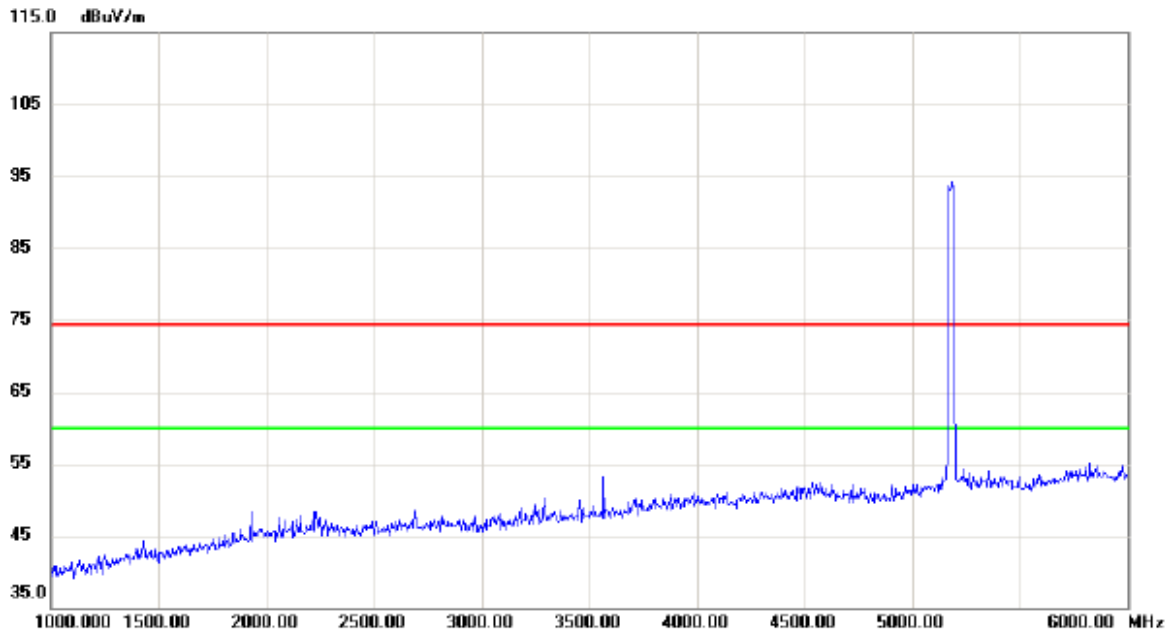

No.	Mk.	Freq.	Reading Level	Correct Factor	Measurement	Limit	Margin	Detector	Comment
		MHz	dBuV	dB	dBuV/m	dBuV/m	dB		

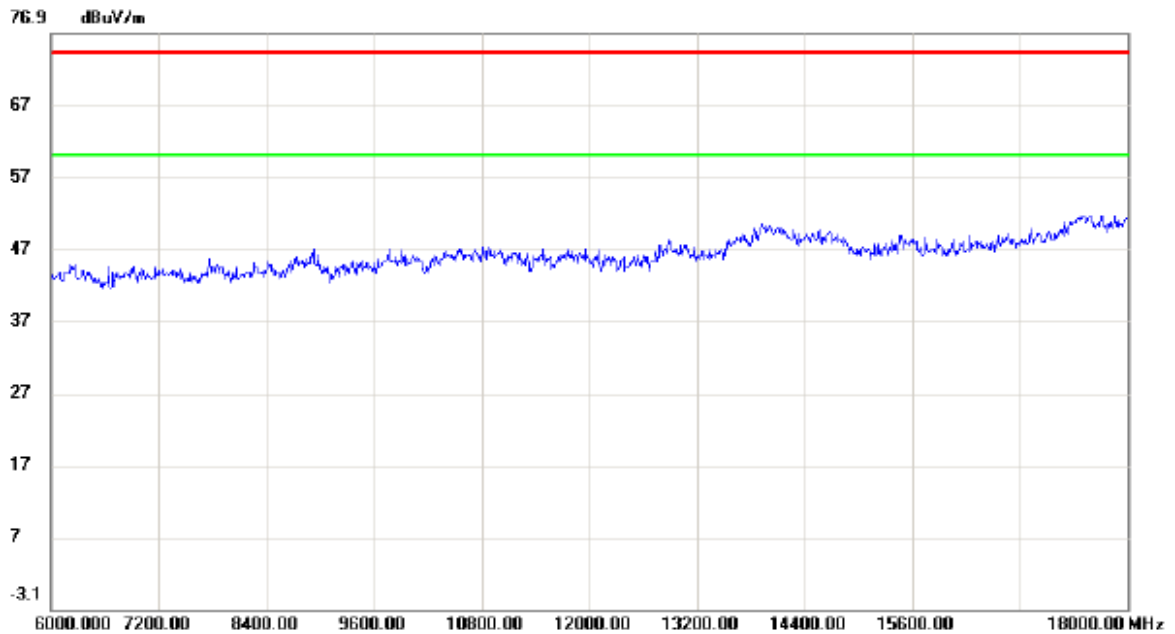

No.	Mk.	Freq.	Reading Level	Correct Factor	Measurement	Limit	Margin	Detector	Comment
		MHz	dBuV	dB	dBuV/m	dBuV/m	dB		

Orthogonal Axis:	X
Test Mode:	UNII-1/ TX N20 Mode 5180MHz

Vertical

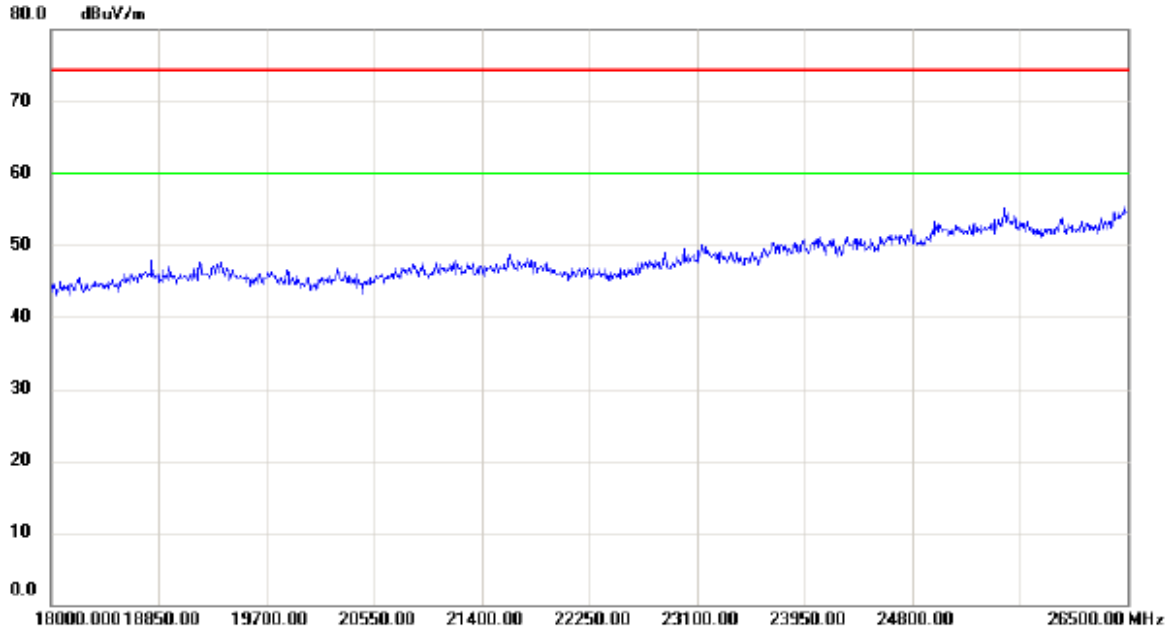

No.	Mk.	Freq.	Reading Level	Correct Factor	Measurement	Limit	Margin	Detector	Comment
		MHz	dBuV	dB	dBuV/m	dBuV/m	dB		

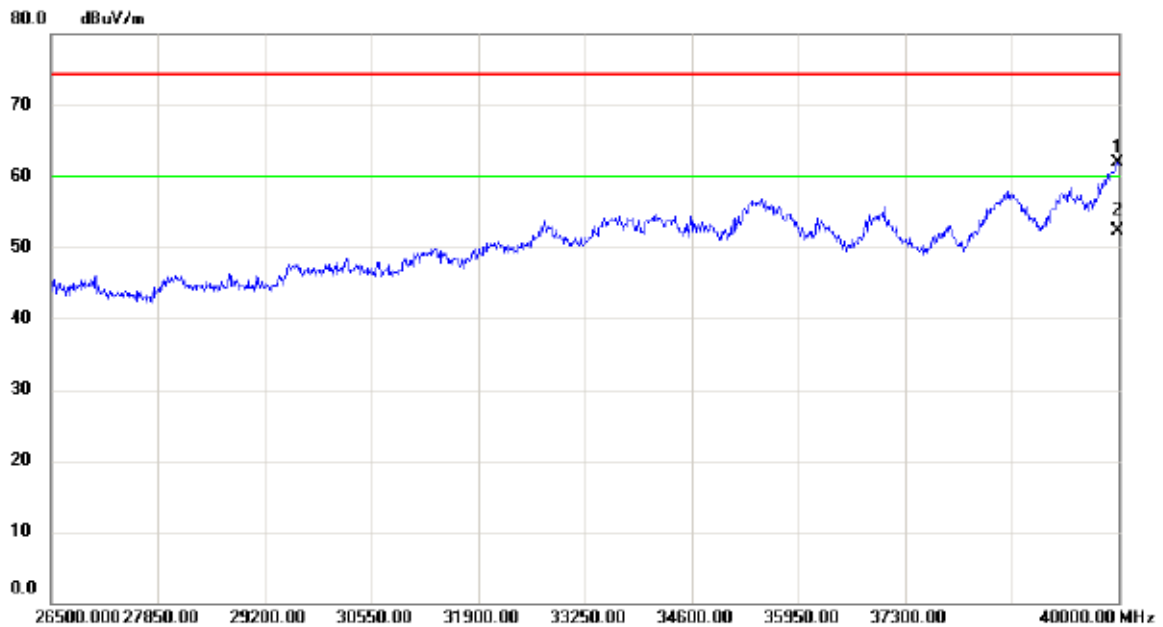

No.	Mk.	Freq.	Reading Level	Correct Factor	Measurement	Limit	Margin	Detector	Comment
		MHz	dBuV	dB	dBuV/m	dBuV/m	dB		
1		39986.50	46.08	15.86	61.94	74.30	-12.36	peak	
2	*	39986.21	36.36	15.86	52.22	60.00	-7.78	AVG	

Orthogonal Axis:	X
Test Mode:	UNII-1/ TX N20 Mode 5180MHz

Horizontal

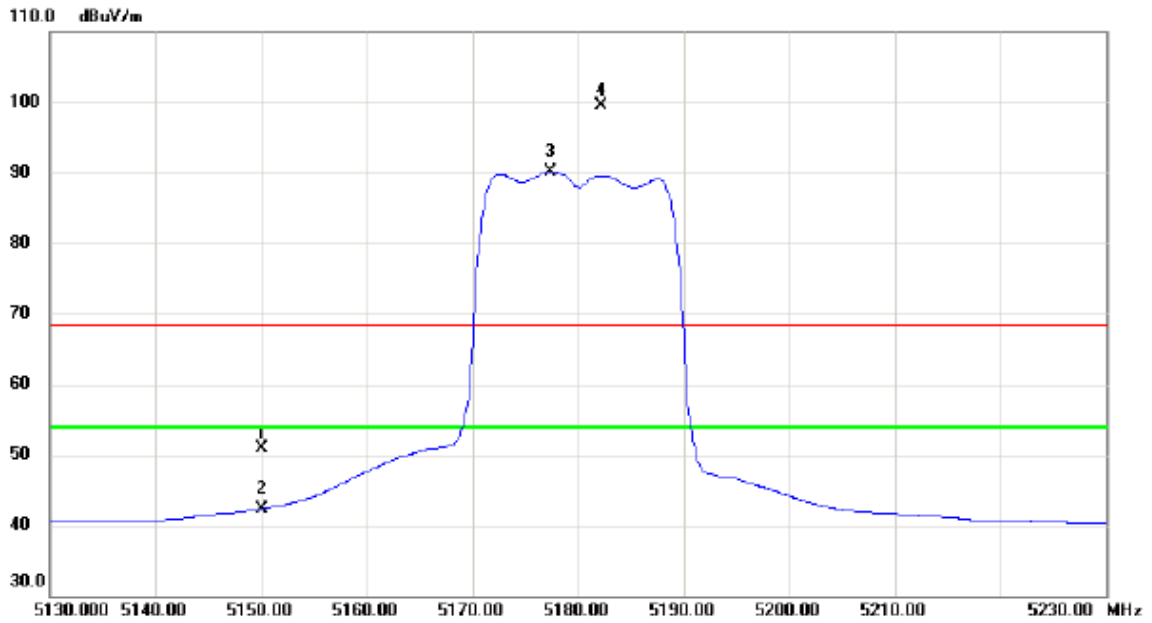

No.	Mk.	Freq. MHz	Reading Level dBuV	Correct Factor dB	Measure- ment dBuV/m	Limit dBuV/m	Margin dB	Detector	Comment
1		5150.000	10.33	40.63	50.96	68.30	-17.34	peak	
2		5150.000	1.70	40.63	42.33	54.00	-11.67	AVG	
3	*	5177.400	49.42	40.72	90.14	54.00	36.14	AVG	No Limit
4	X	5182.200	58.81	40.73	99.54	68.30	31.24	peak	No Limit

Orthogonal Axis:	X
Test Mode:	UNII-1/ TX N20 Mode 5180MHz

Horizontal

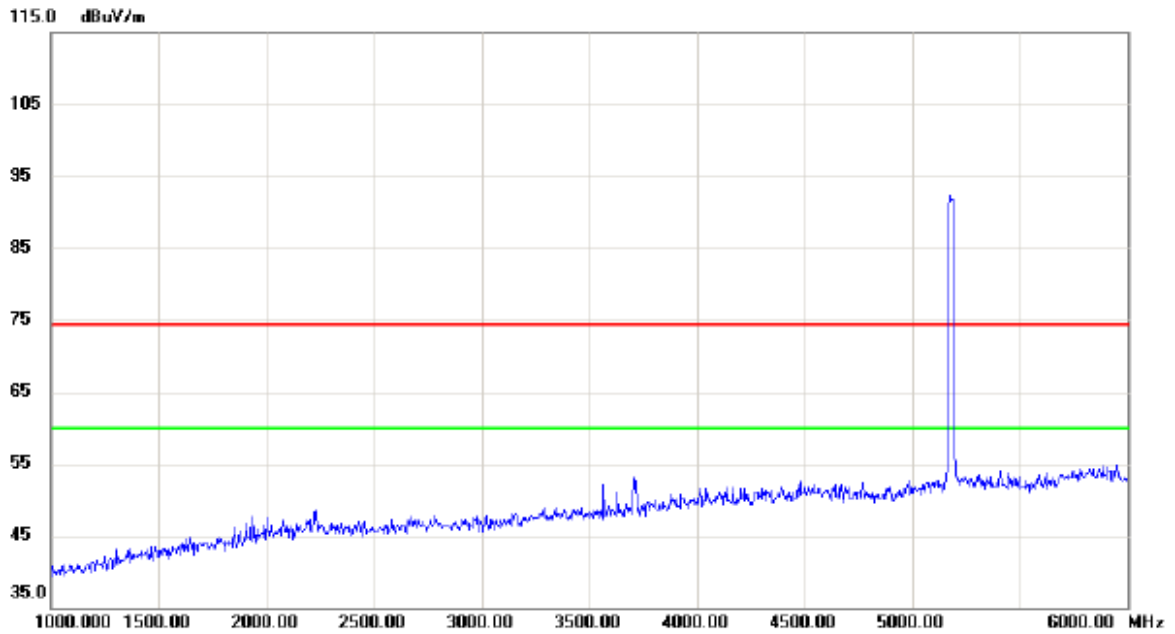

No.	Mk.	Freq.	Reading Level	Correct Factor	Measurement	Limit	Margin	Detector	Comment
		MHz	dBuV	dB	dBuV/m	dBuV/m	dB		

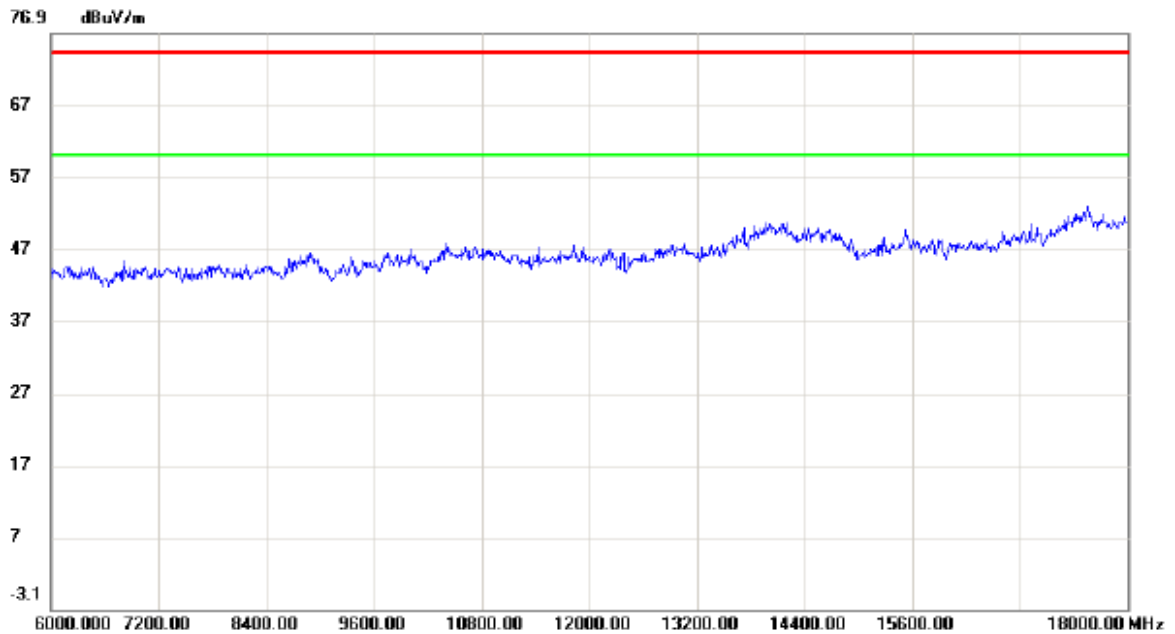

No.	Mk.	Freq.	Reading Level	Correct Factor	Measurement	Limit	Margin	Detector	Comment
		MHz	dBuV	dB	dBuV/m	dBuV/m	dB		

Orthogonal Axis:	X
Test Mode:	UNII-1/ TX N20 Mode 5180MHz

Horizontal

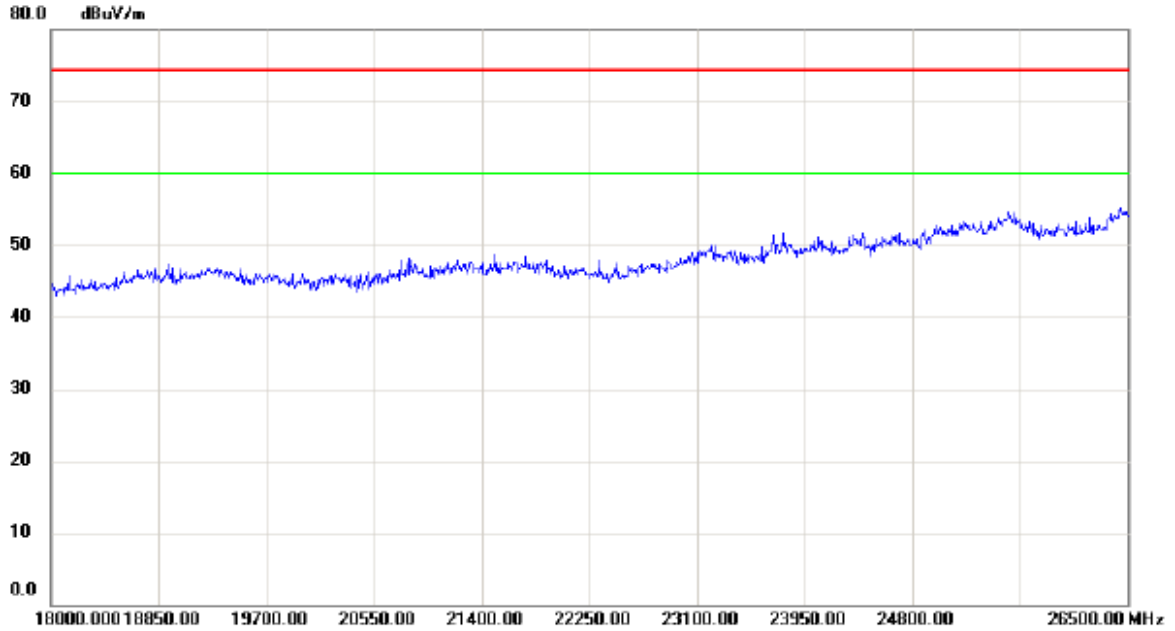

No.	Mk.	Freq.	Reading Level	Correct Factor	Measurement	Limit	Margin	Detector	Comment
		MHz	dBuV	dB	dBuV/m	dBuV/m	dB		

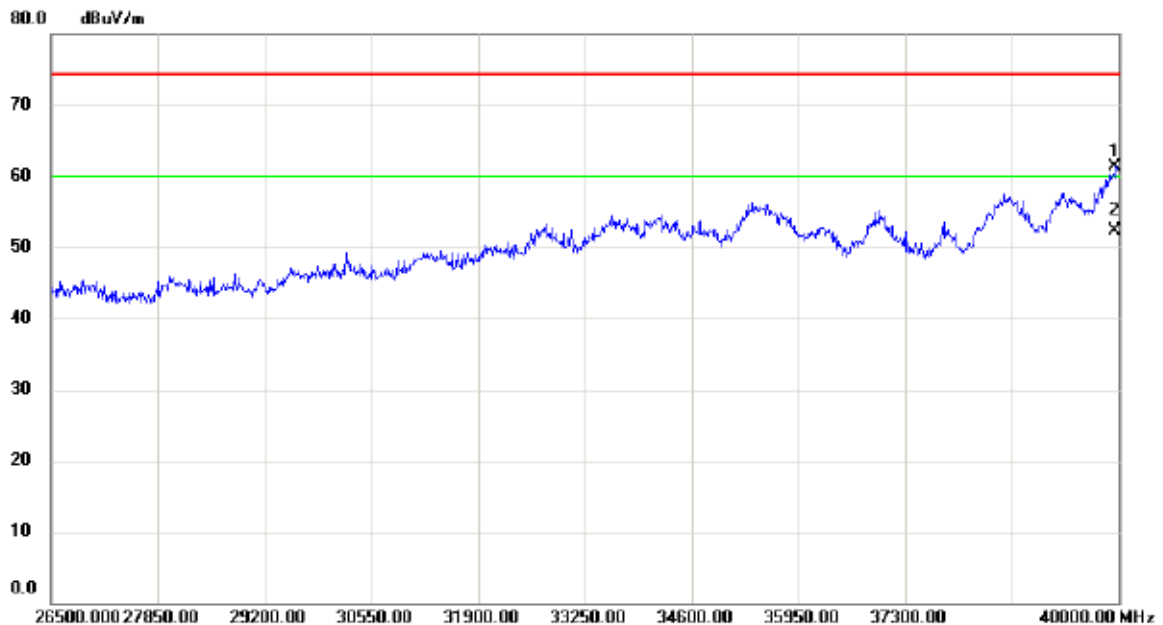

No.	Mk.	Freq.	Reading Level	Correct Factor	Measurement	Limit	Margin	Detector	Comment
		MHz	dBuV	dB	dBuV/m	dBuV/m	dB		
1		39959.50	45.41	15.82	61.23	74.30	-13.07	peak	
2	*	39959.50	36.39	15.82	52.21	60.00	-7.79	AVG	

Orthogonal Axis:	X
Test Mode:	UNII-1/ TX N20 Mode 5240MHz

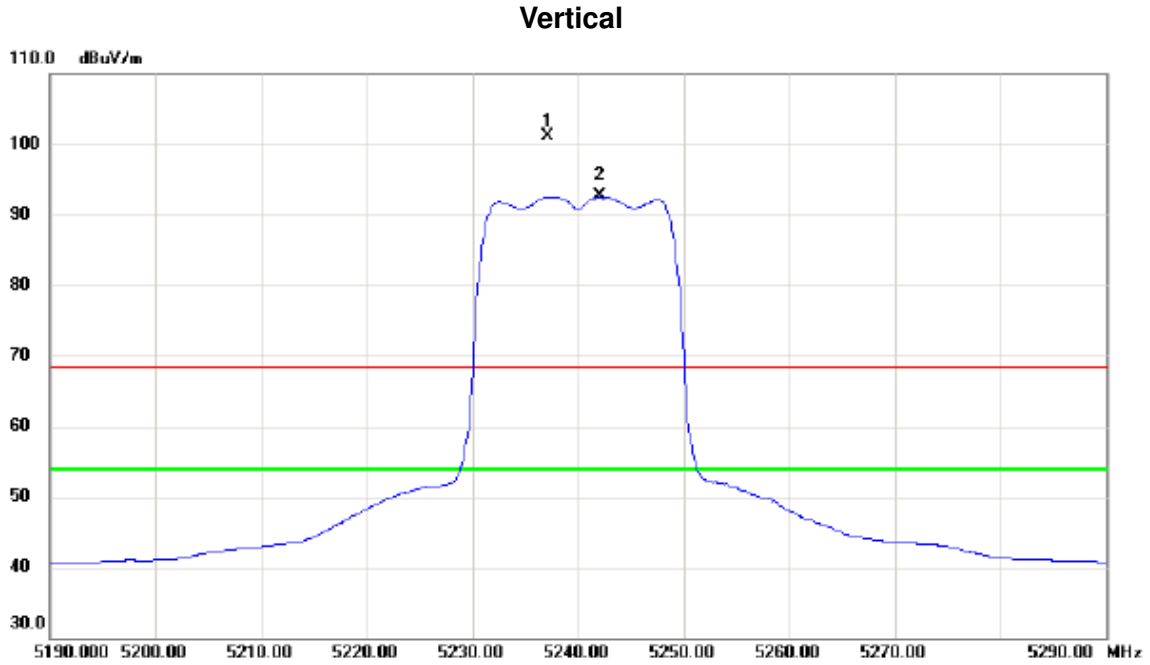

No.	Mk.	Freq.	Reading Level	Correct Factor	Measurement	Limit	Margin	Detector	Comment
		MHz	dBuV	dB	dBuV/m	dBuV/m	dB		
1	X	5237.100	60.15	40.91	101.06	68.30	32.76	peak	No Limit
2	*	5242.100	51.68	40.93	92.61	54.00	38.61	AVG	No Limit

Orthogonal Axis:	X
Test Mode:	UNII-1/ TX N20 Mode 5240MHz

Vertical

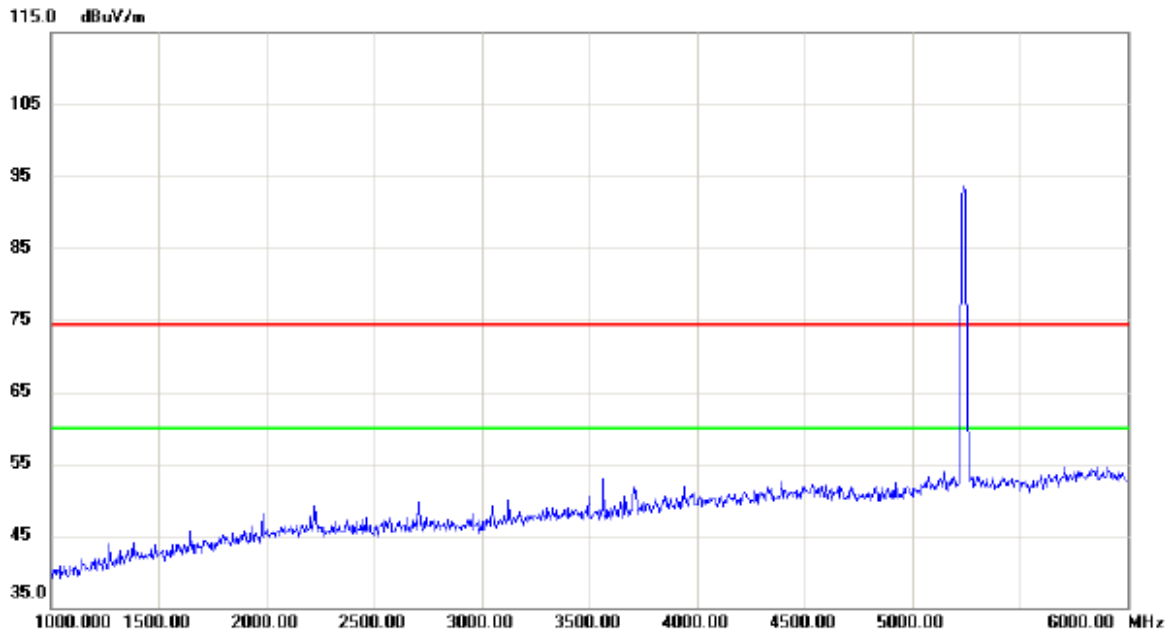

No.	Mk.	Freq.	Reading Level	Correct Factor	Measurement	Limit	Margin	Detector	Comment
		MHz	dBuV	dB	dBuV/m	dBuV/m	dB		

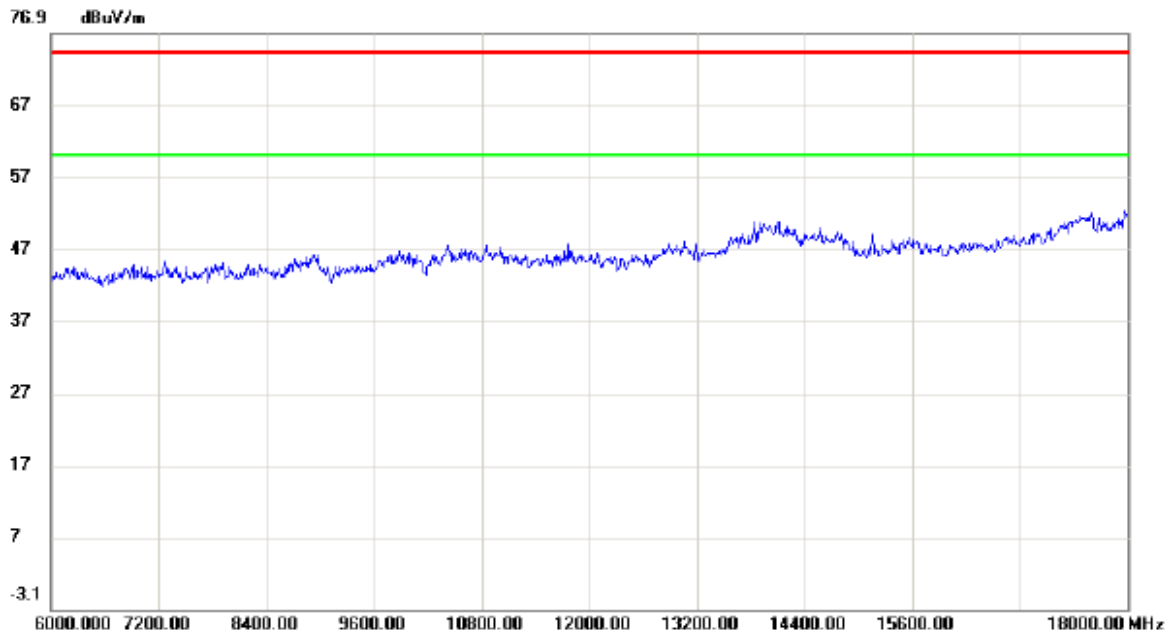

No.	Mk.	Freq.	Reading Level	Correct Factor	Measurement	Limit	Margin	Detector	Comment
		MHz	dBuV	dB	dBuV/m	dBuV/m	dB		

Orthogonal Axis:	X
Test Mode:	UNII-1/ TX N20 Mode 5240MHz

Vertical

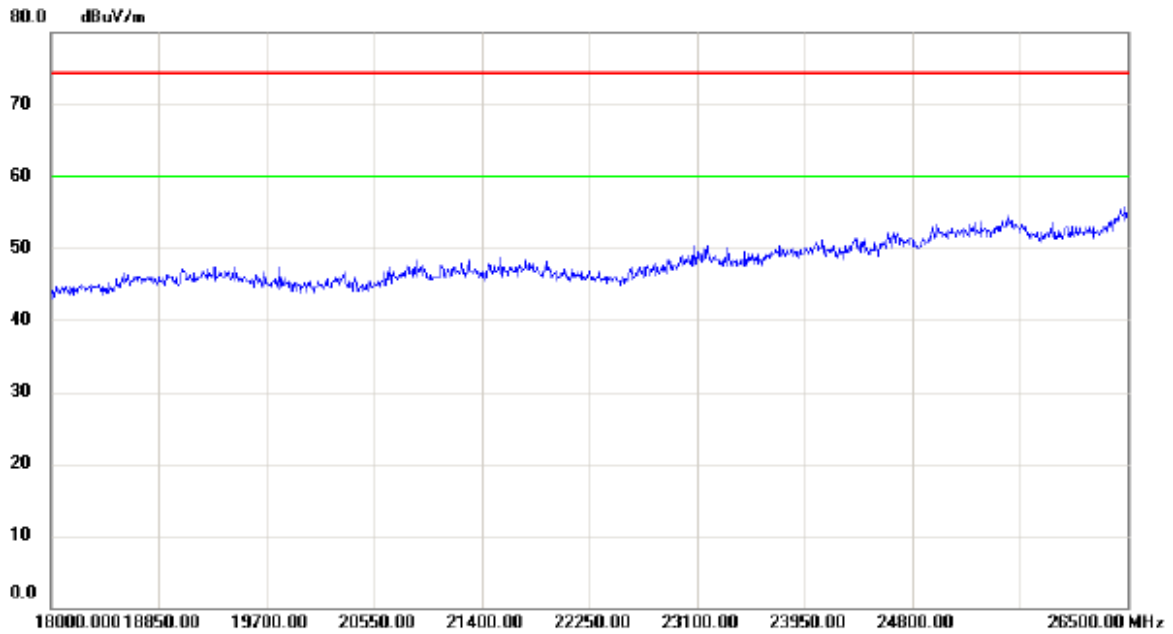

No.	Mk.	Freq.	Reading Level	Correct Factor	Measurement	Limit	Margin	Detector	Comment
		MHz	dBuV	dB	dBuV/m	dBuV/m	dB		

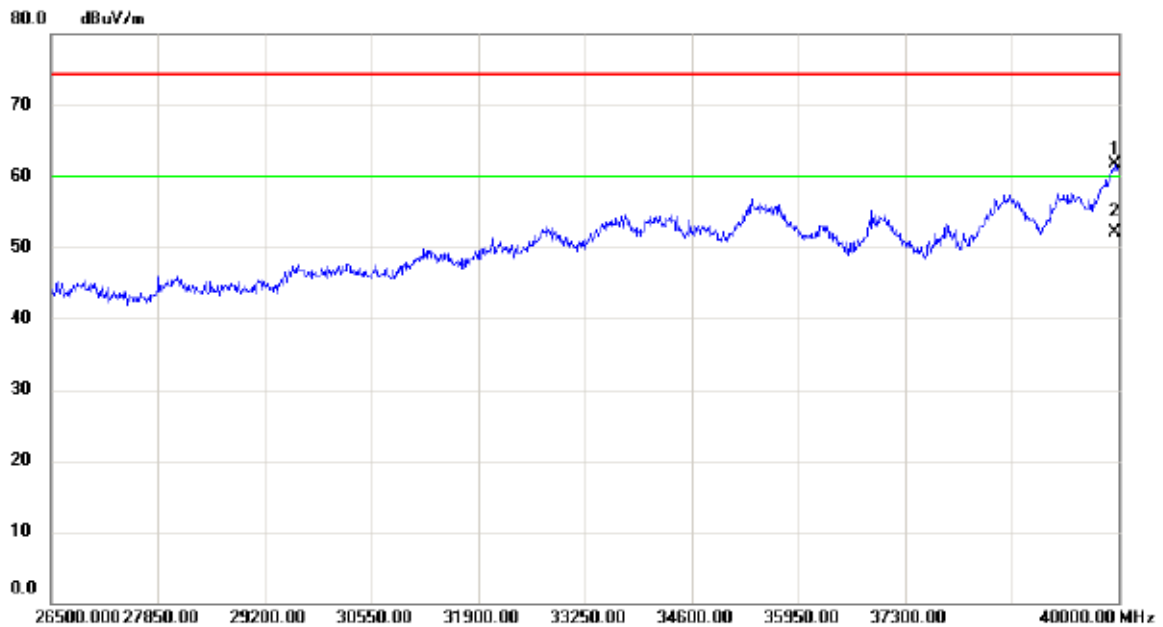

No.	Mk.	Freq.	Reading Level	Correct Factor	Measurement	Limit	Margin	Detector	Comment
		MHz	dBuV	dB	dBuV/m	dBuV/m	dB		
1		39959.50	45.87	15.82	61.69	74.30	-12.61	peak	
2	*	39959.63	36.26	15.82	52.08	60.00	-7.92	AVG	

Orthogonal Axis:	X
Test Mode:	UNII-1/ TX N20 Mode 5240MHz

Horizontal

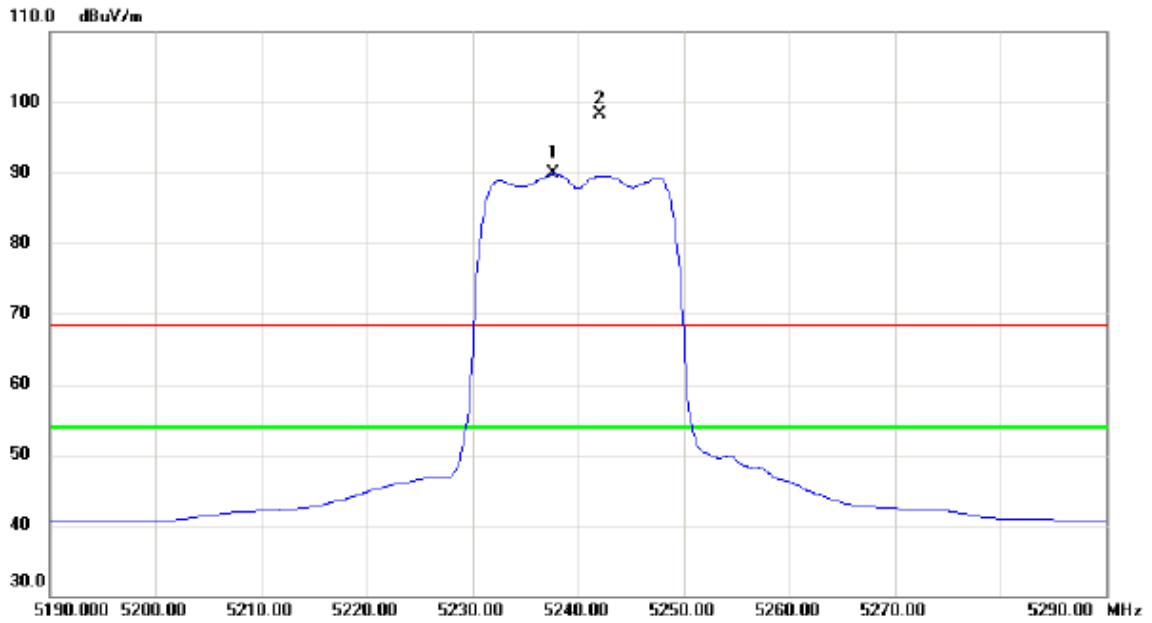

No.	Mk.	Freq.	Reading Level	Correct Factor	Measurement	Limit	Margin	Detector	Comment
		MHz	dBuV	dB	dBuV/m	dBuV/m	dB		
1	*	5237.700	48.91	40.91	89.82	54.00	35.82	AVG	No Limit
2	X	5242.000	57.33	40.93	98.26	68.30	29.96	peak	No Limit

Orthogonal Axis:	X
Test Mode:	UNII-1/ TX N20 Mode 5240MHz

Horizontal

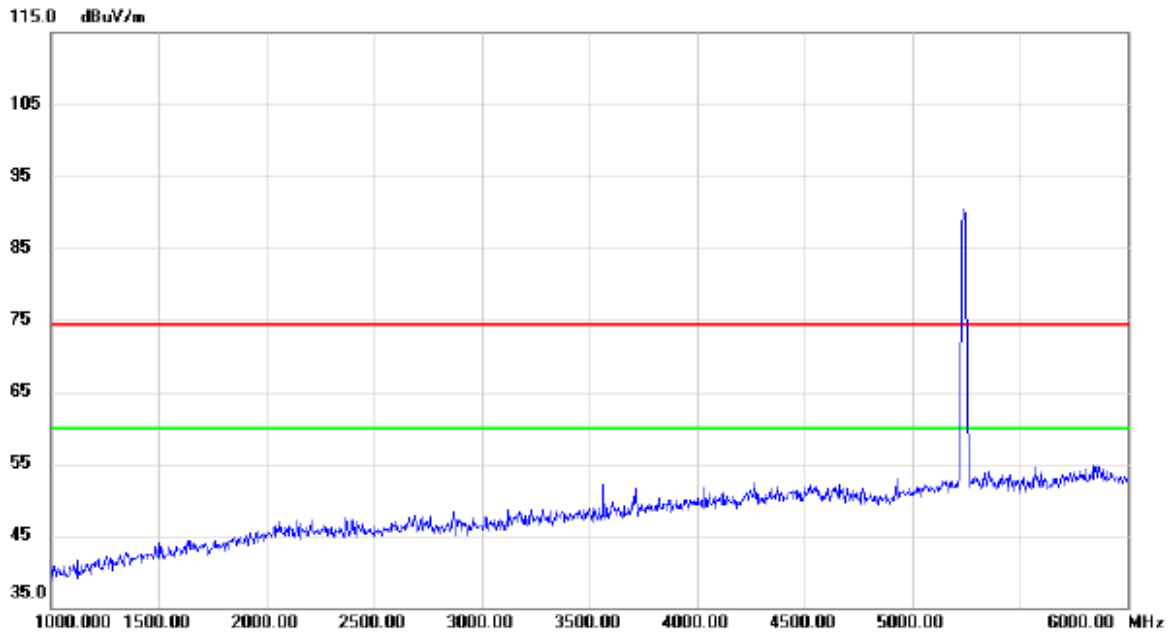

No.	Mk.	Freq.	Reading Level	Correct Factor	Measurement	Limit	Margin	Detector	Comment
		MHz	dBuV	dB	dBuV/m	dBuV/m	dB		

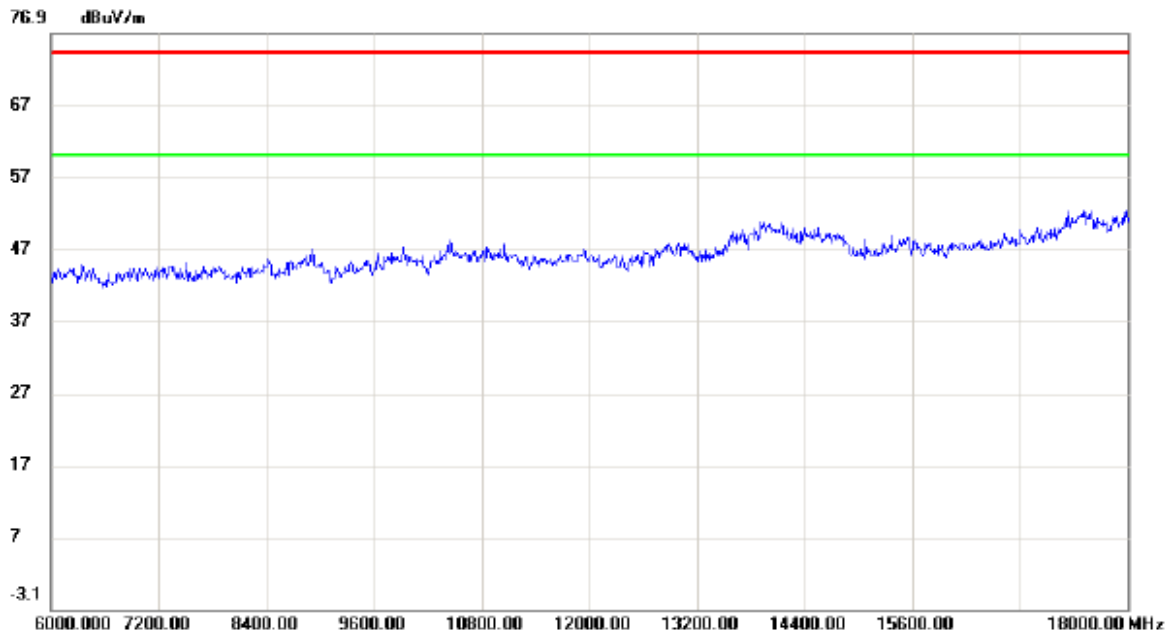

No.	Mk.	Freq.	Reading Level	Correct Factor	Measurement	Limit	Margin	Detector	Comment
		MHz	dBuV	dB	dBuV/m	dBuV/m	dB		

Orthogonal Axis:	X
Test Mode:	UNII-1/ TX N20 Mode 5240MHz

Horizontal

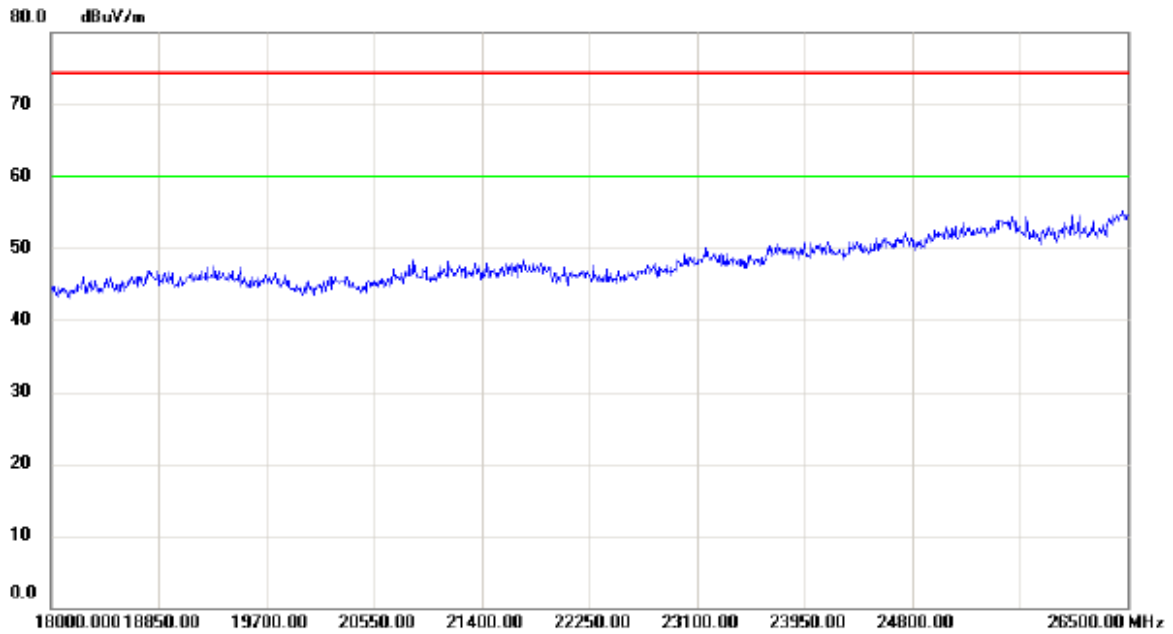

No.	Mk.	Freq.	Reading Level	Correct Factor	Measurement	Limit	Margin	Detector	Comment
		MHz	dBuV	dB	dBuV/m	dBuV/m	dB		

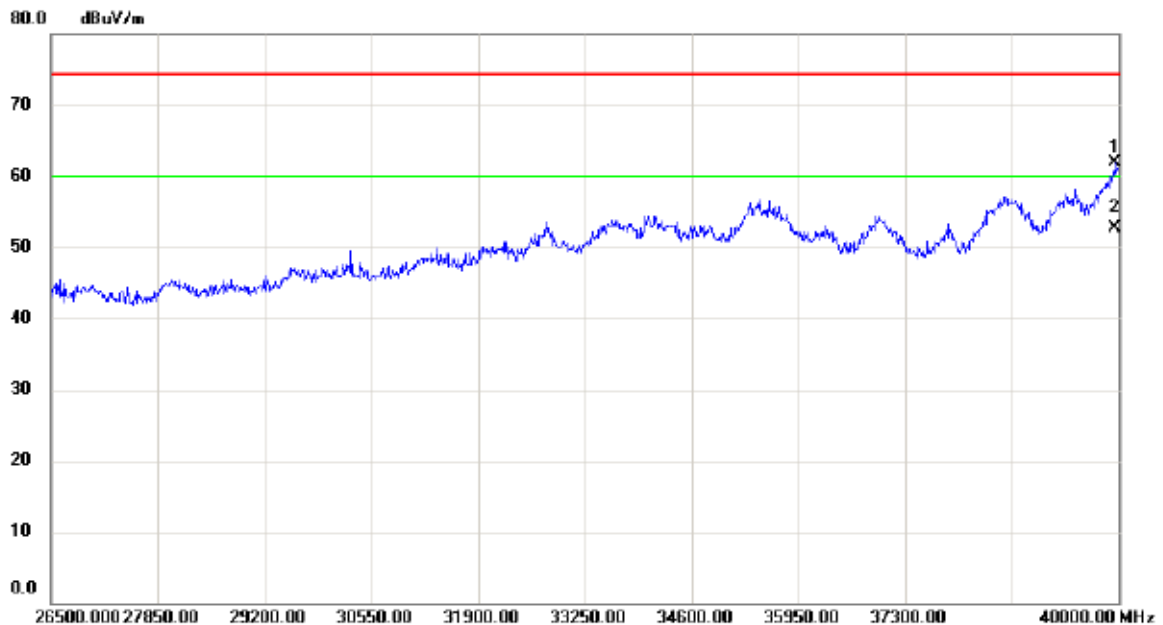

No.	Mk.	Freq.	Reading Level	Correct Factor	Measurement	Limit	Margin	Detector	Comment
		MHz	dBuV	dB	dBuV/m	dBuV/m	dB		
1		39959.50	46.03	15.82	61.85	74.30	-12.45	peak	
2	*	39959.10	36.96	15.82	52.78	60.00	-7.22	AVG	

Orthogonal Axis:	X
Test Mode:	UNII-1/ TX N40 Mode 5190MHz

Vertical

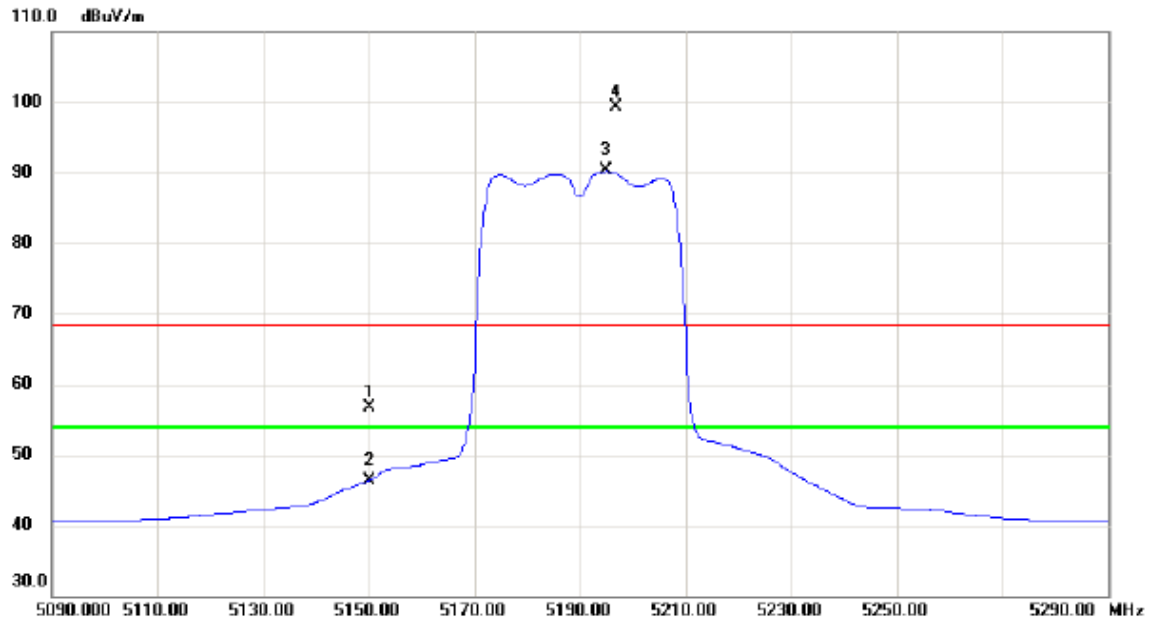

No.	Mk.	Freq.	Reading Level	Correct Factor	Measurement	Limit	Margin	Detector	Comment
		MHz	dBuV	dB	dBuV/m	dBuV/m	dB		
1		5150.000	16.15	40.63	56.78	68.30	-11.52	peak	
2		5150.000	5.71	40.63	46.34	54.00	-7.66	AVG	
3	*	5195.000	49.43	40.78	90.21	54.00	36.21	AVG	No Limit
4	X	5196.800	58.59	40.78	99.37	68.30	31.07	peak	No Limit

Orthogonal Axis:	X
Test Mode:	UNII-1/ TX N40 Mode 5190MHz

Vertical

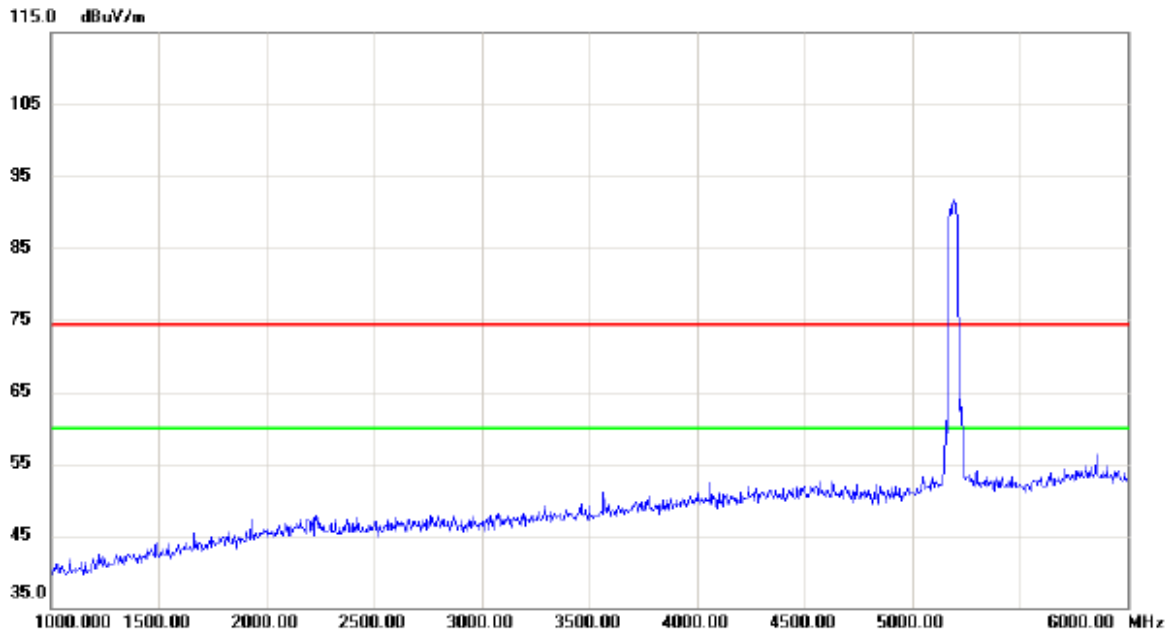

No.	Mk.	Freq.	Reading Level	Correct Factor	Measurement	Limit	Margin	Detector	Comment
		MHz	dBuV	dB	dBuV/m	dBuV/m	dB		

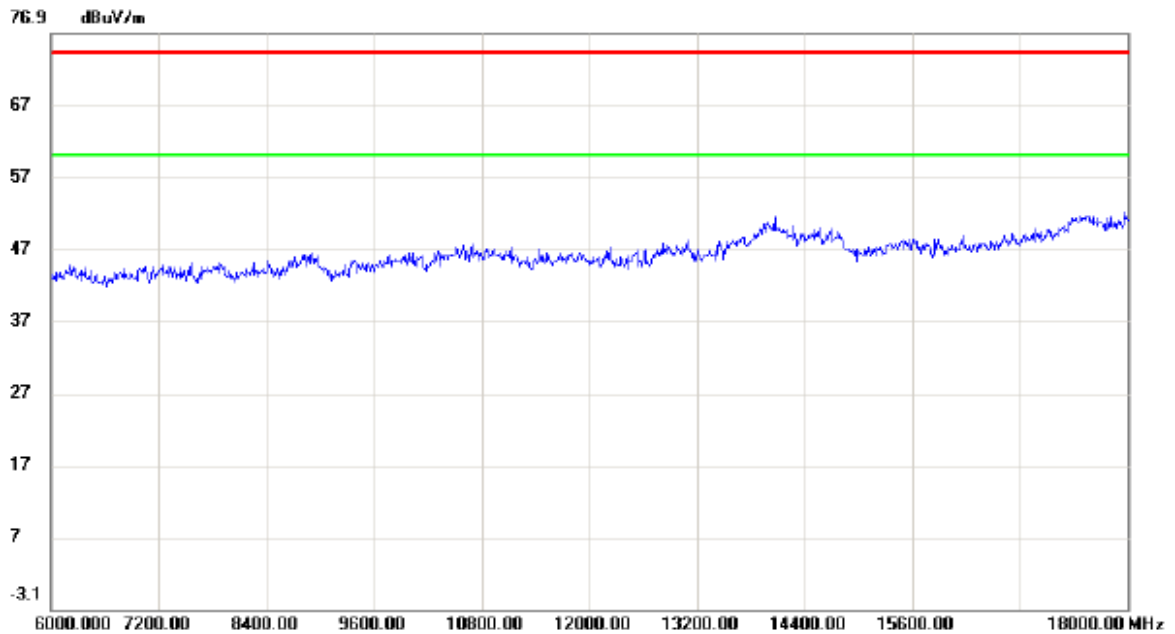

No.	Mk.	Freq.	Reading Level	Correct Factor	Measurement	Limit	Margin	Detector	Comment
		MHz	dBuV	dB	dBuV/m	dBuV/m	dB		

Orthogonal Axis:	X
Test Mode:	UNII-1/ TX N40 Mode 5190MHz

Vertical

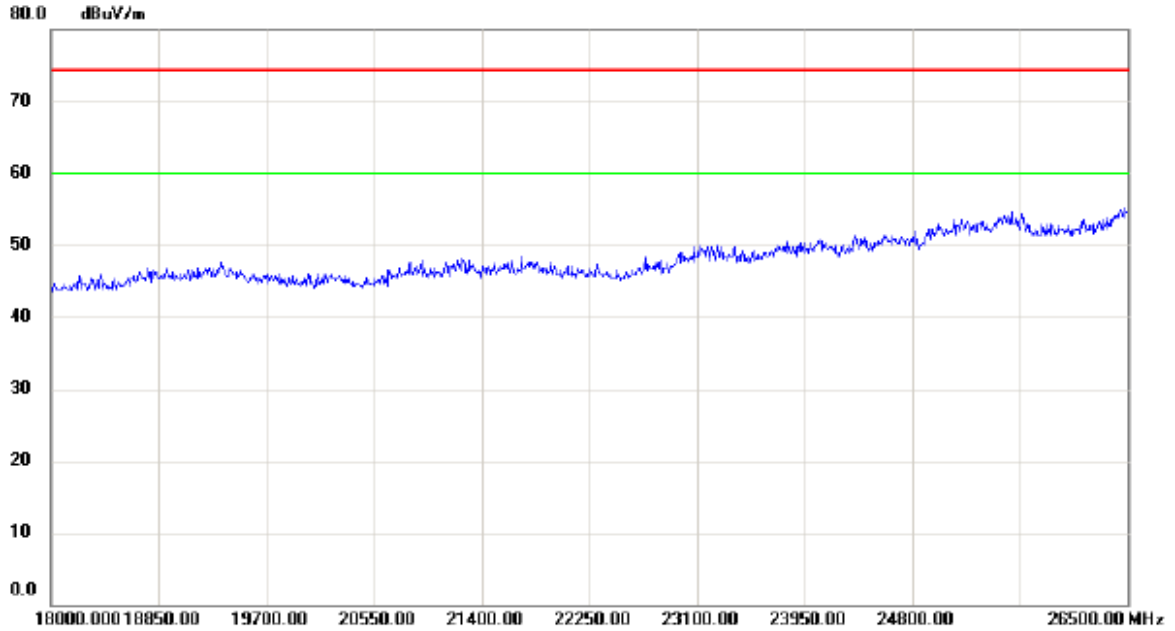

No.	Mk.	Freq.	Reading Level	Correct Factor	Measurement	Limit	Margin	Detector	Comment
		MHz	dBuV	dB	dBuV/m	dBuV/m	dB		

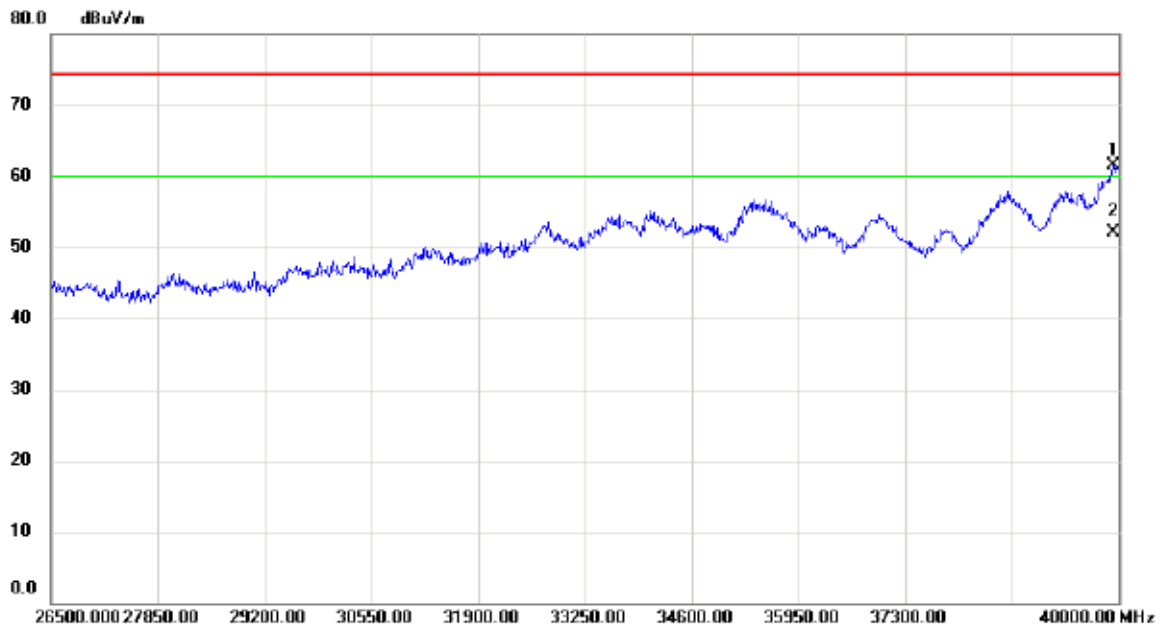

No.	Mk.	Freq.	Reading Level	Correct Factor	Measurement	Limit	Margin	Detector	Comment
		MHz	dBuV	dB	dBuV/m	dBuV/m	dB		
1		39932.50	45.63	15.78	61.41	74.30	-12.89	peak	
2	*	39932.35	36.26	15.78	52.04	60.00	-7.96	AVG	

Orthogonal Axis:	X
Test Mode:	UNII-1/ TX N40 Mode 5190MHz

Horizontal

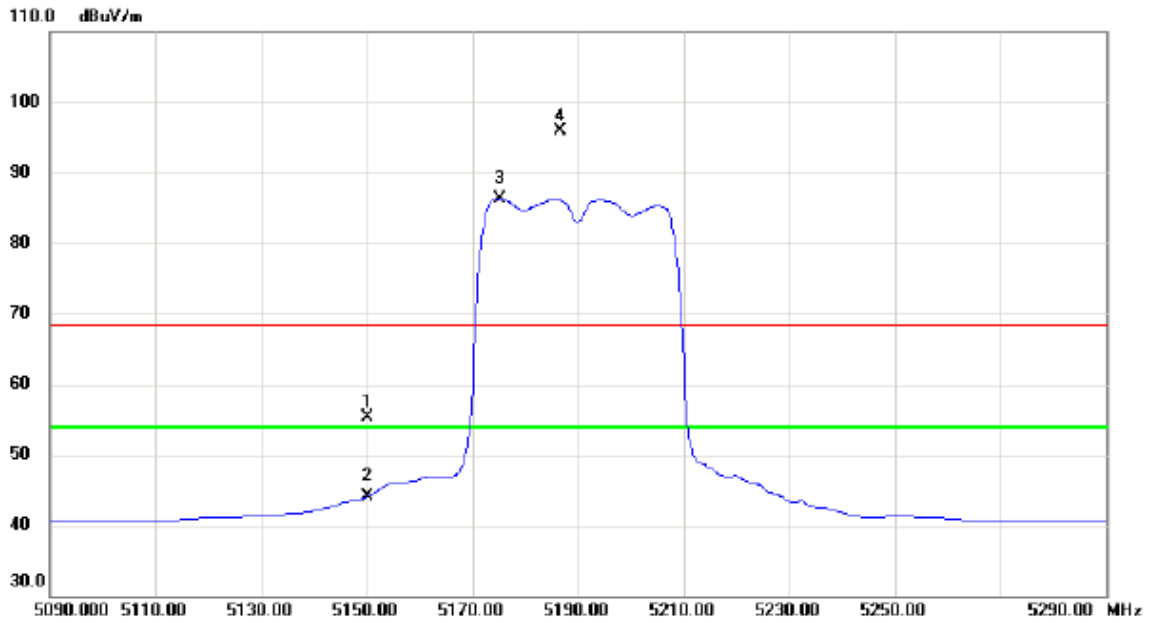

No.	Mk.	Freq.	Reading Level	Correct Factor	Measurement	Limit	Margin	Detector	Comment
		MHz	dBuV	dB	dBuV/m	dBuV/m	dB		
1		5150.000	14.64	40.63	55.27	68.30	-13.03	peak	
2		5150.000	3.44	40.63	44.07	54.00	-9.93	AVG	
3	*	5175.200	45.52	40.71	86.23	54.00	32.23	AVG	No Limit
4	X	5186.600	55.23	40.75	95.98	68.30	27.68	peak	No Limit

Orthogonal Axis:	X
Test Mode:	UNII-1/ TX N40 Mode 5190MHz

Horizontal

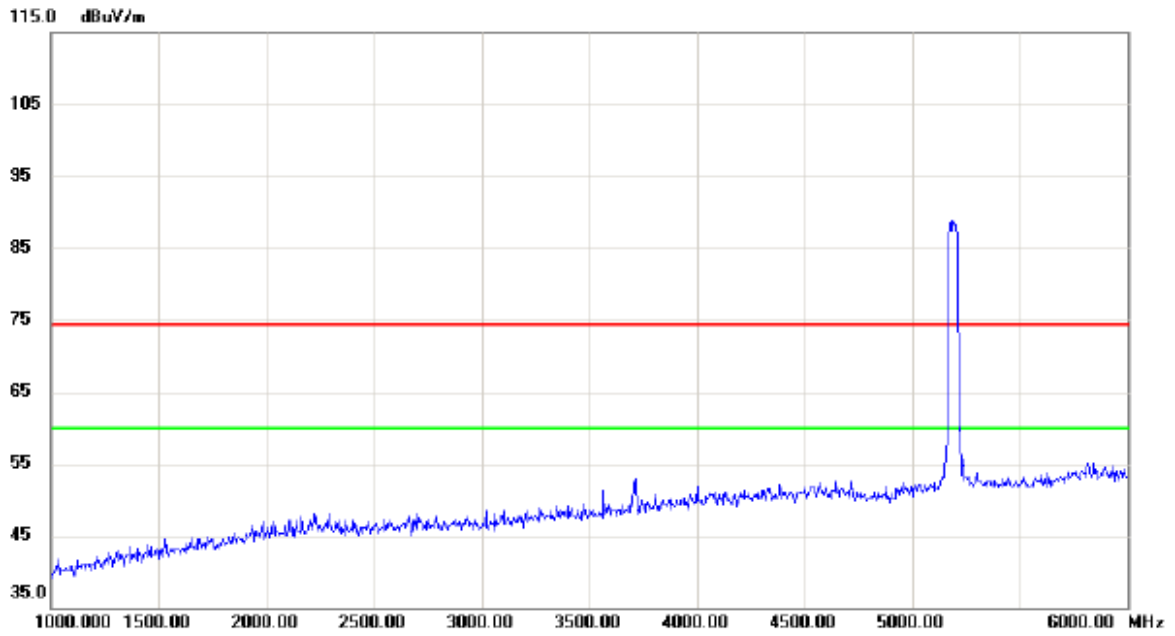

No.	Mk.	Freq.	Reading Level	Correct Factor	Measurement	Limit	Margin	Detector	Comment
		MHz	dBuV	dB	dBuV/m	dBuV/m	dB		

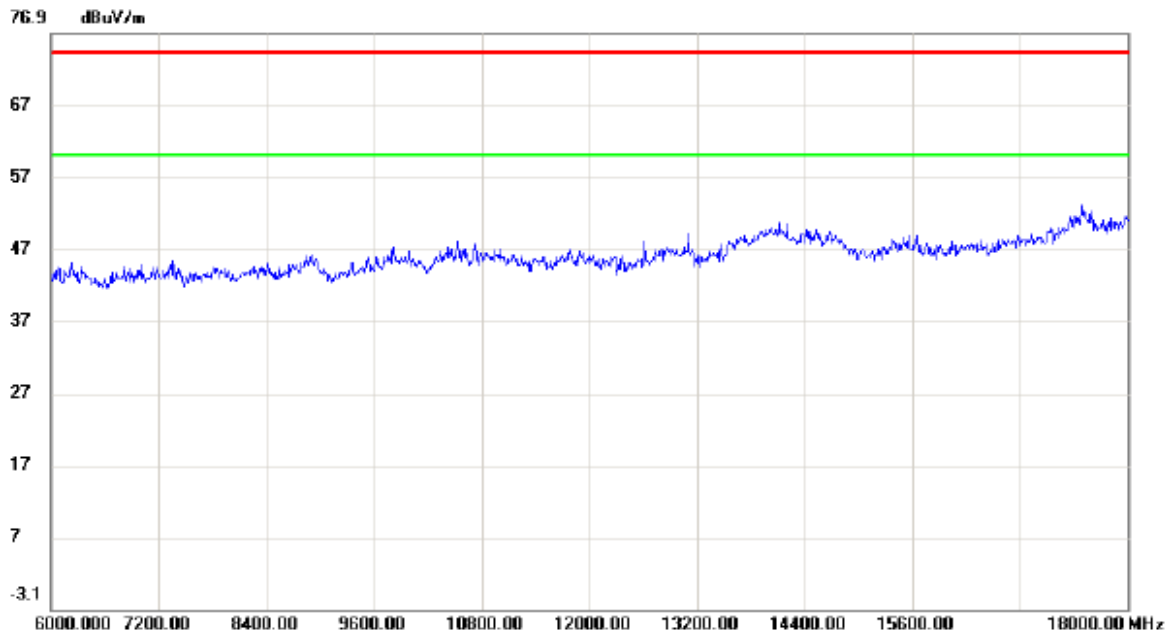

No.	Mk.	Freq.	Reading Level	Correct Factor	Measurement	Limit	Margin	Detector	Comment
		MHz	dBuV	dB	dBuV/m	dBuV/m	dB		

Orthogonal Axis:	X
Test Mode:	UNII-1/ TX N40 Mode 5190MHz

Horizontal

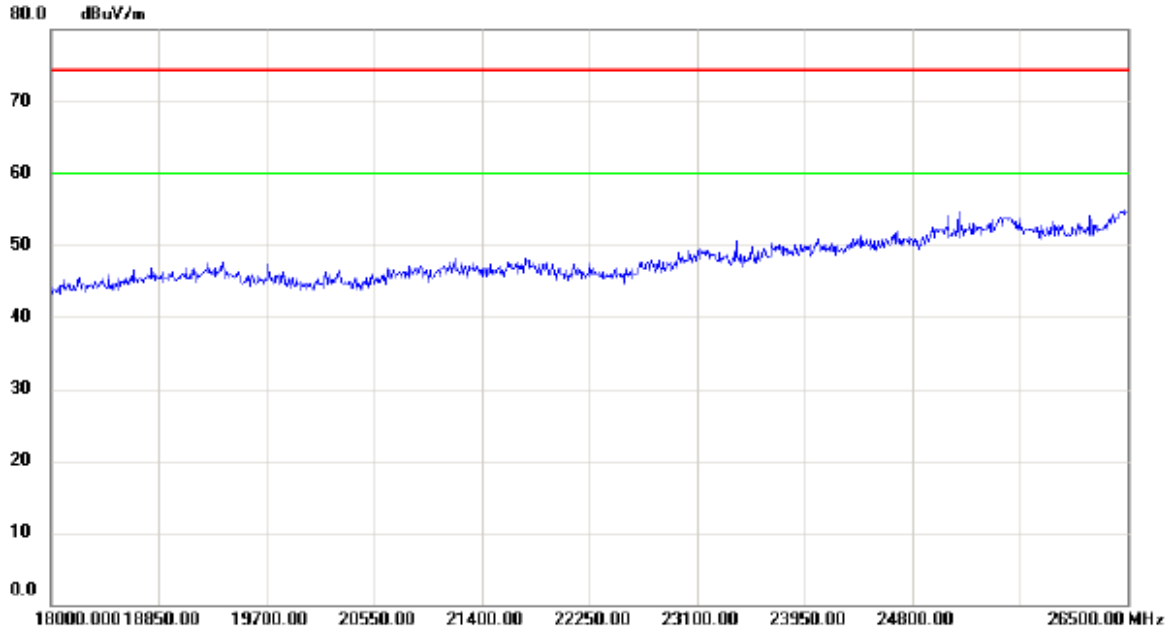

No.	Mk.	Freq.	Reading Level	Correct Factor	Measurement	Limit	Margin	Detector	Comment
		MHz	dBuV	dB	dBuV/m	dBuV/m	dB		

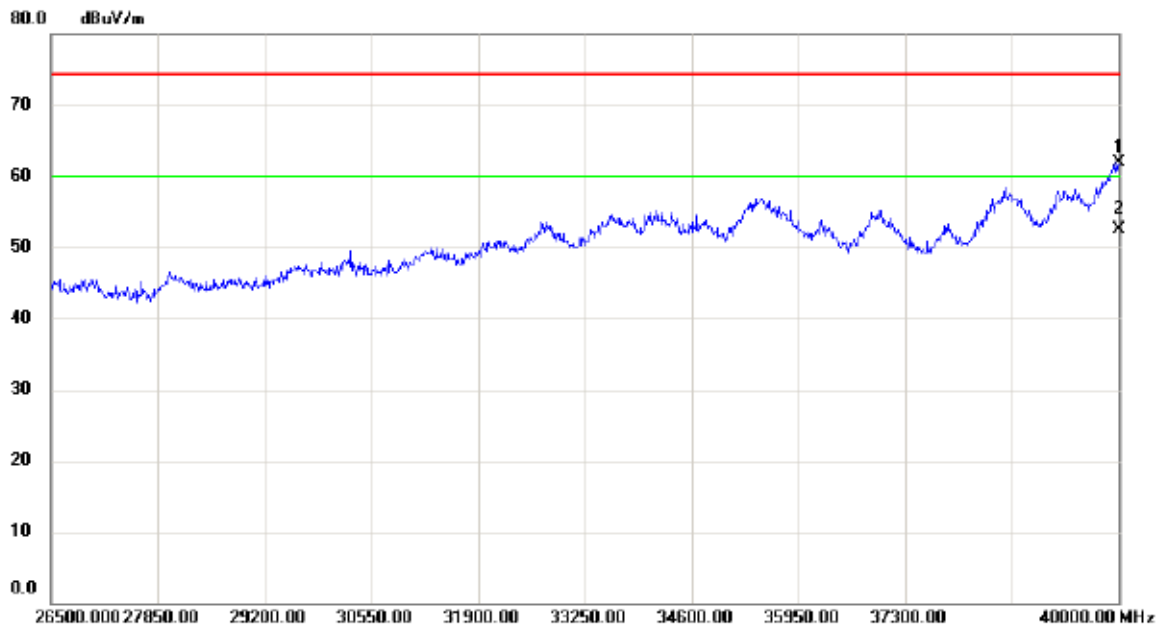

No.	Mk.	Freq.	Reading Level	Correct Factor	Measurement	Limit	Margin	Detector	Comment
		MHz	dBuV	dB	dBuV/m	dBuV/m	dB		
1		40000.00	46.05	15.89	61.94	74.30	-12.36	peak	
2	*	40000.00	36.63	15.89	52.52	60.00	-7.48	AVG	

Orthogonal Axis:	X
Test Mode:	UNII-1/ TX N40 Mode 5230MHz

Vertical

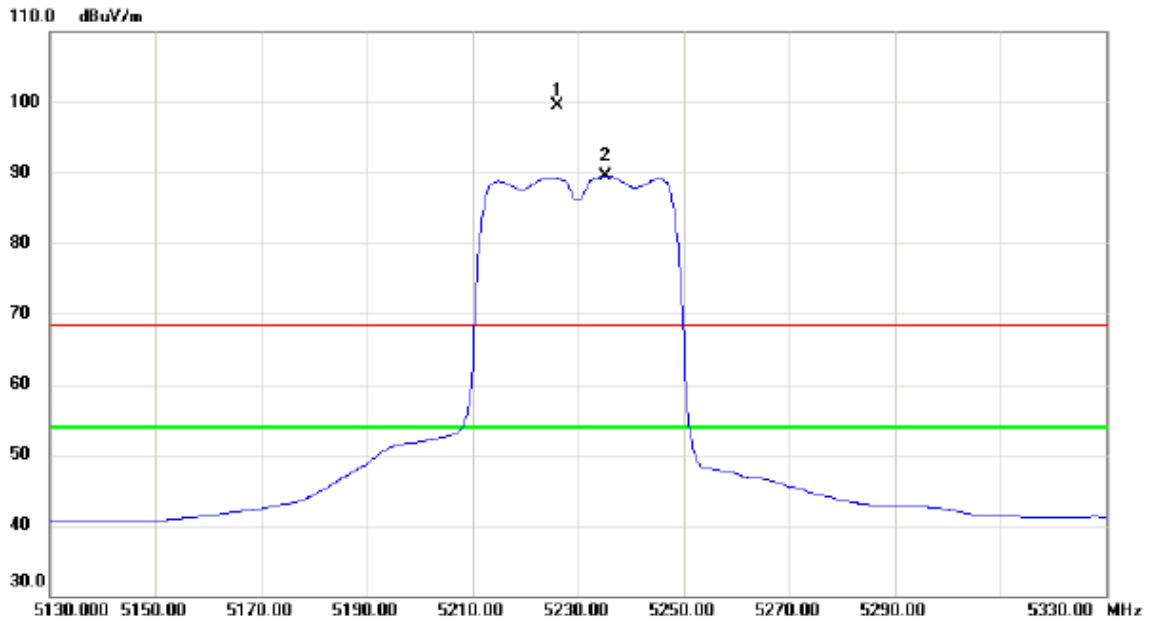

No.	Mk.	Freq.	Reading Level	Correct Factor	Measurement	Limit	Margin		
		MHz	dBuV	dB	dBuV/m	dBuV/m	dB	Detector	Comment
1	X	5226.000	58.56	40.87	99.43	68.30	31.13	peak	No Limit
2	*	5235.200	48.66	40.90	89.56	54.00	35.56	AVG	No Limit

Orthogonal Axis:	X
Test Mode:	UNII-1/ TX N40 Mode 5230MHz

Vertical

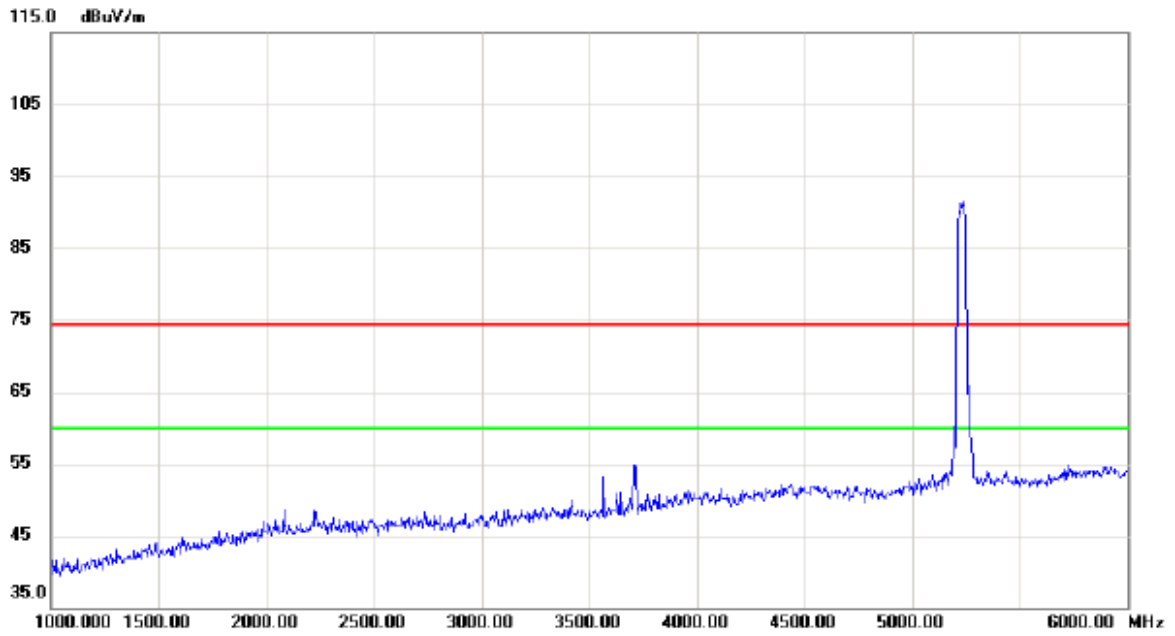

No.	Mk.	Freq.	Reading Level	Correct Factor	Measurement	Limit	Margin	Detector	Comment
		MHz	dBuV	dB	dBuV/m	dBuV/m	dB		

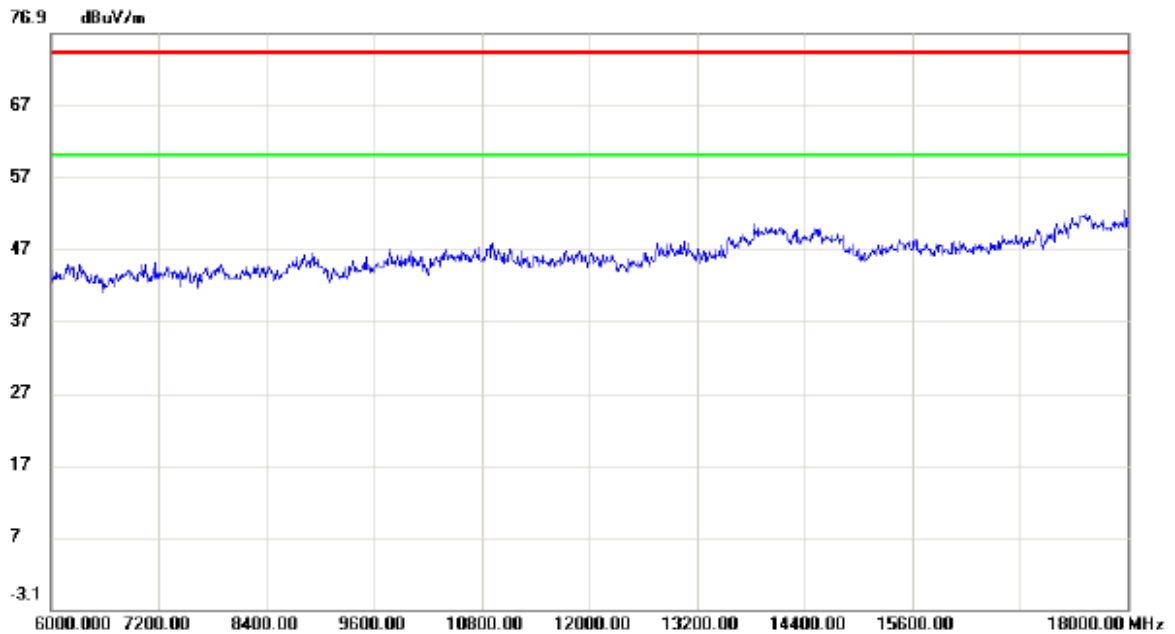

No.	Mk.	Freq.	Reading Level	Correct Factor	Measurement	Limit	Margin	Detector	Comment
		MHz	dBuV	dB	dBuV/m	dBuV/m	dB		

Orthogonal Axis:	X
Test Mode:	UNII-1/ TX N40 Mode 5230MHz

Vertical

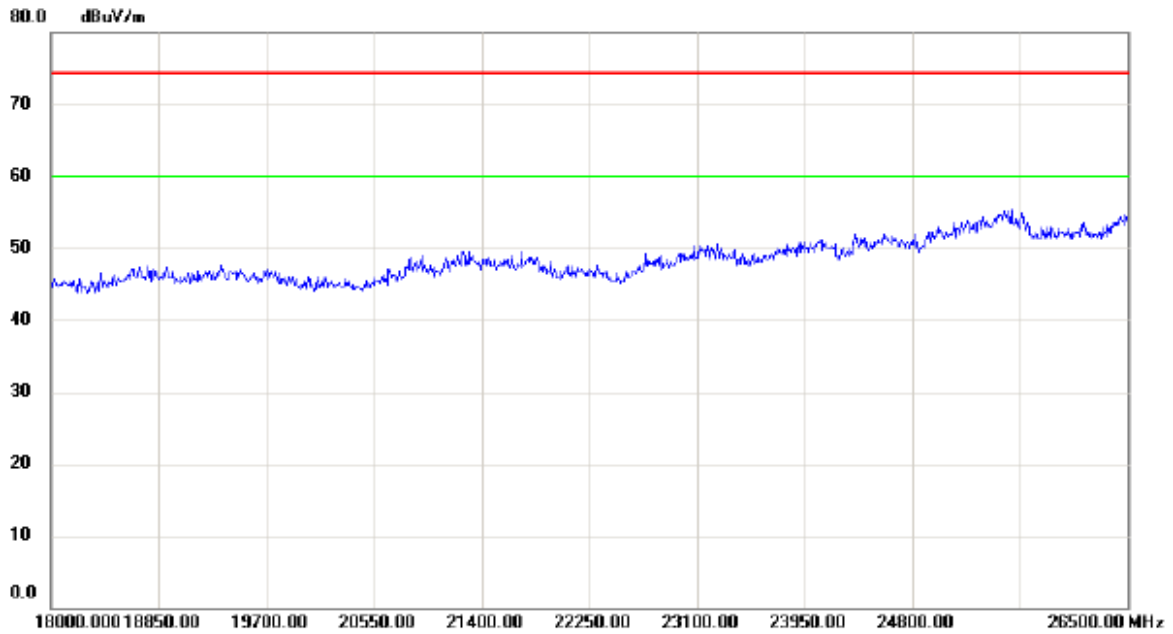

No.	Mk.	Freq.	Reading Level	Correct Factor	Measurement	Limit	Margin	Detector	Comment
		MHz	dBuV	dB	dBuV/m	dBuV/m	dB		

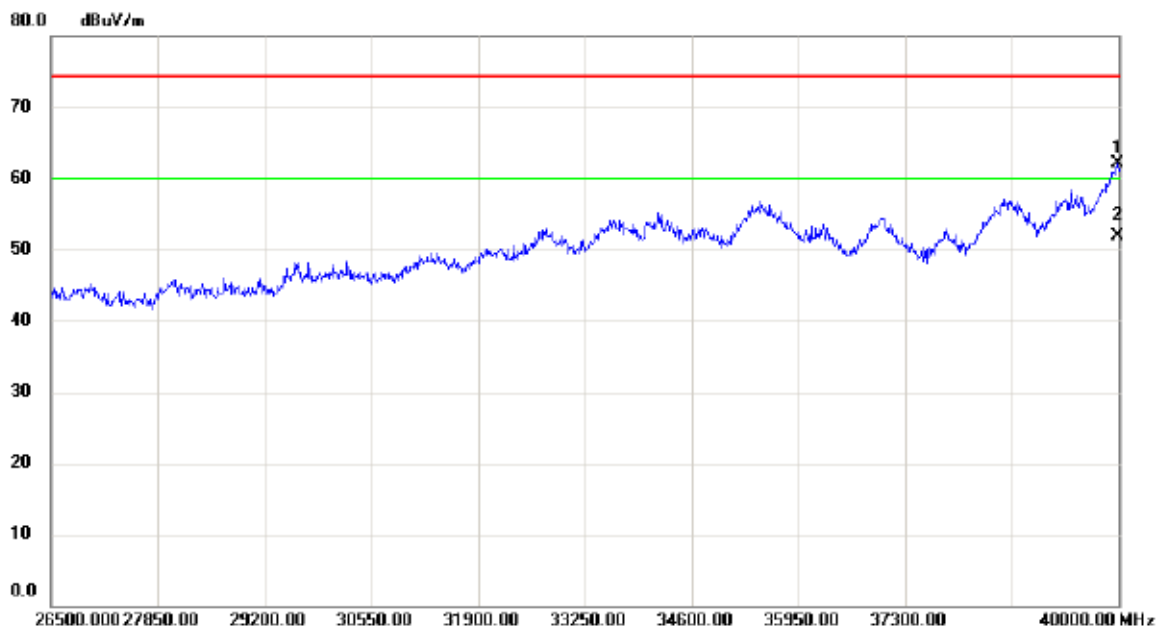

No.	Mk.	Freq.	Reading Level	Correct Factor	Measurement	Limit	Margin	Detector	Comment
		MHz	dBuV	dB	dBuV/m	dBuV/m	dB		
1		39986.50	46.16	15.86	62.02	74.30	-12.28	peak	
2	*	39986.53	36.11	15.86	51.97	60.00	-8.03	AVG	

Orthogonal Axis:	X
Test Mode:	UNII-1/ TX N40 Mode 5230MHz

Horizontal

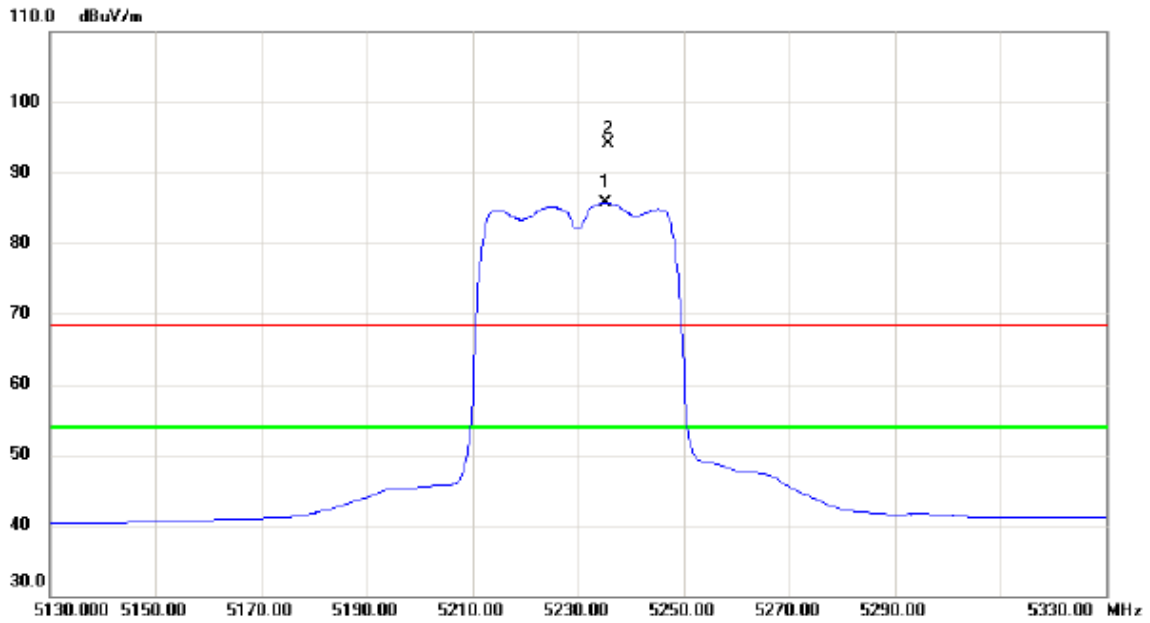

No.	Mk.	Freq.	Reading Level	Correct Factor	Measurement	Limit	Margin	Detector	Comment
		MHz	dBuV	dB	dBuV/m	dBuV/m	dB		
1	X	5235.200	44.81	40.90	85.71	68.30	17.41	QP	No Limit
2	*	5235.600	53.11	40.91	94.02	68.30	25.72	peak	No Limit

Orthogonal Axis:	X
Test Mode:	UNII-1/ TX N40 Mode 5230MHz

Horizontal

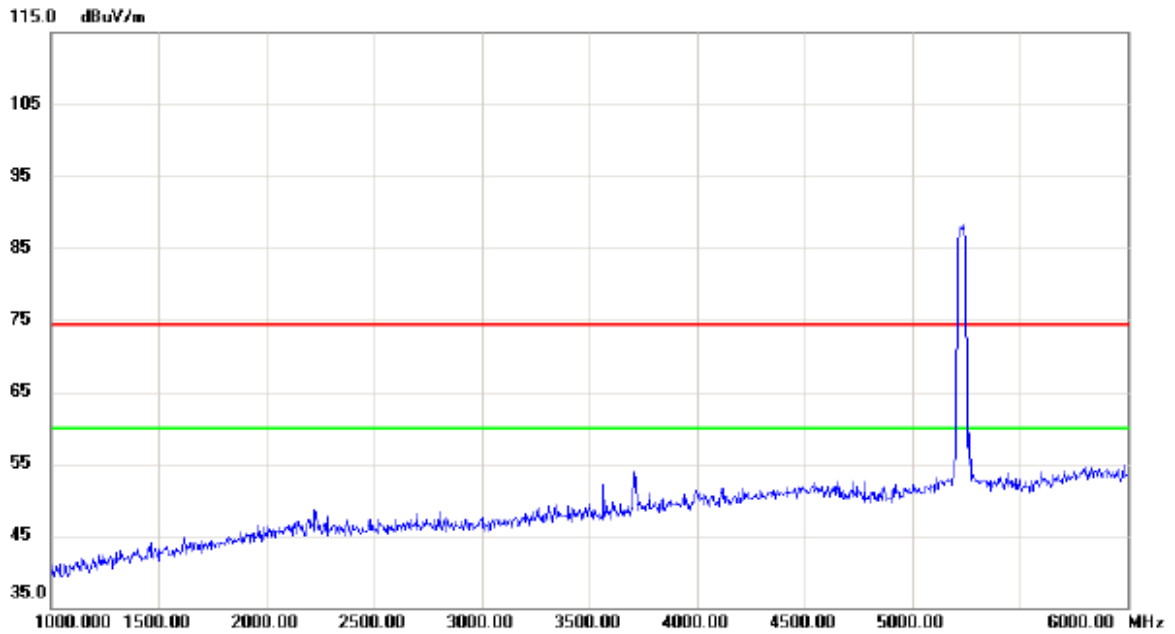

No.	Mk.	Freq.	Reading Level	Correct Factor	Measurement	Limit	Margin	Detector	Comment
		MHz	dBuV	dB	dBuV/m	dBuV/m	dB		

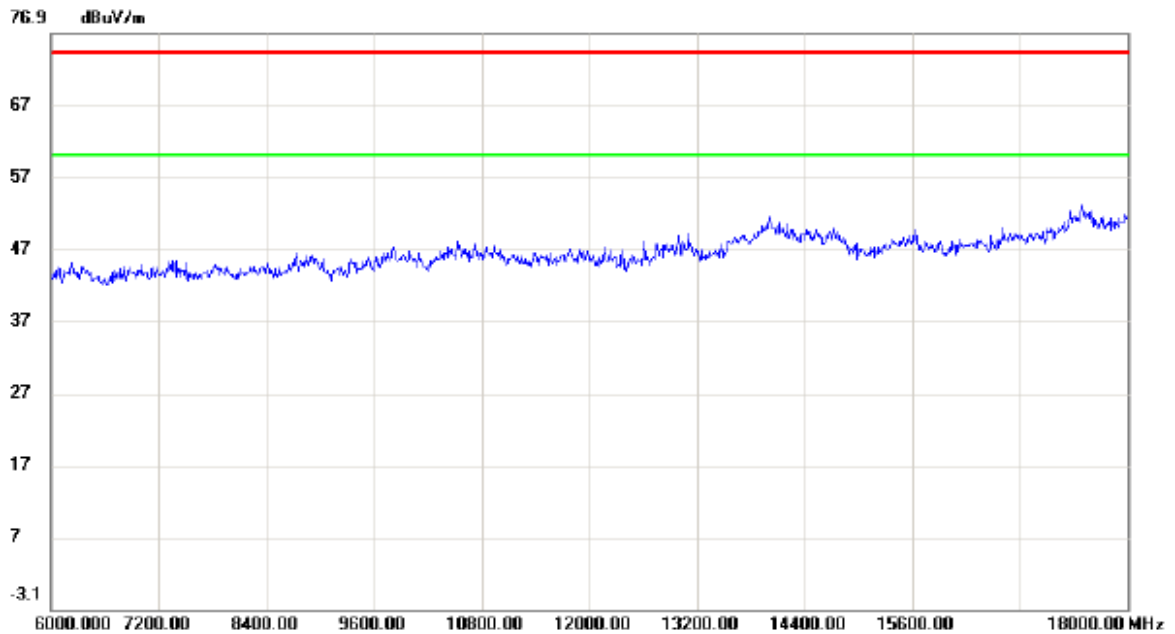

No.	Mk.	Freq.	Reading Level	Correct Factor	Measurement	Limit	Margin	Detector	Comment
		MHz	dBuV	dB	dBuV/m	dBuV/m	dB		

Orthogonal Axis:	X
Test Mode:	UNII-1/ TX N40 Mode 5230MHz

Horizontal

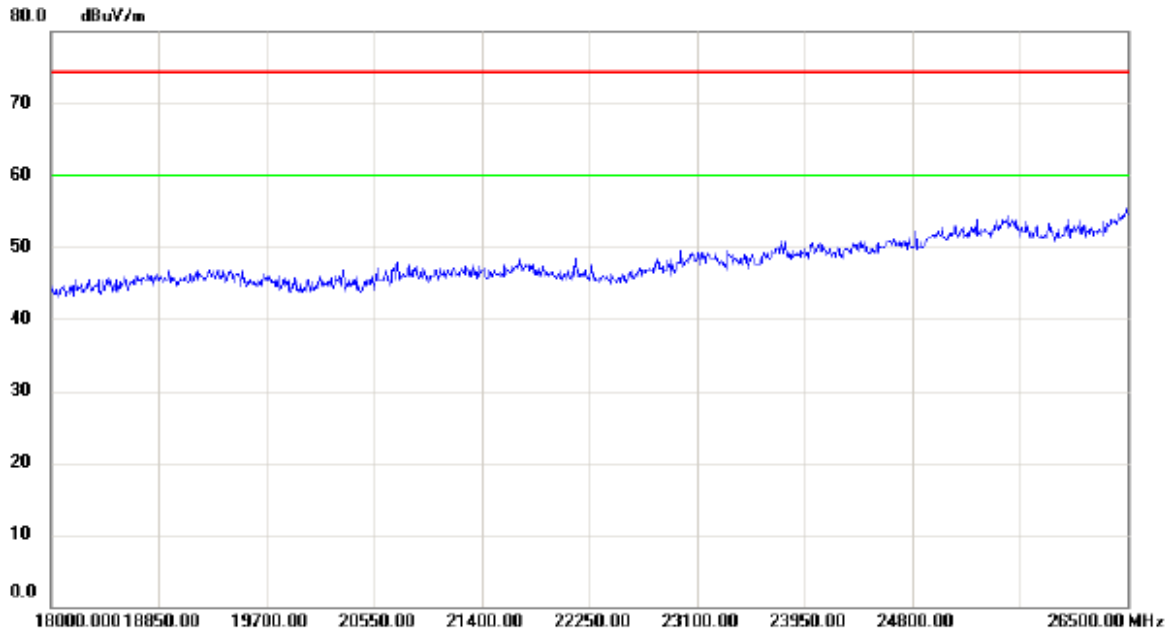

No.	Mk.	Freq.	Reading Level	Correct Factor	Measurement	Limit	Margin	Detector	Comment
		MHz	dBuV	dB	dBuV/m	dBuV/m	dB		

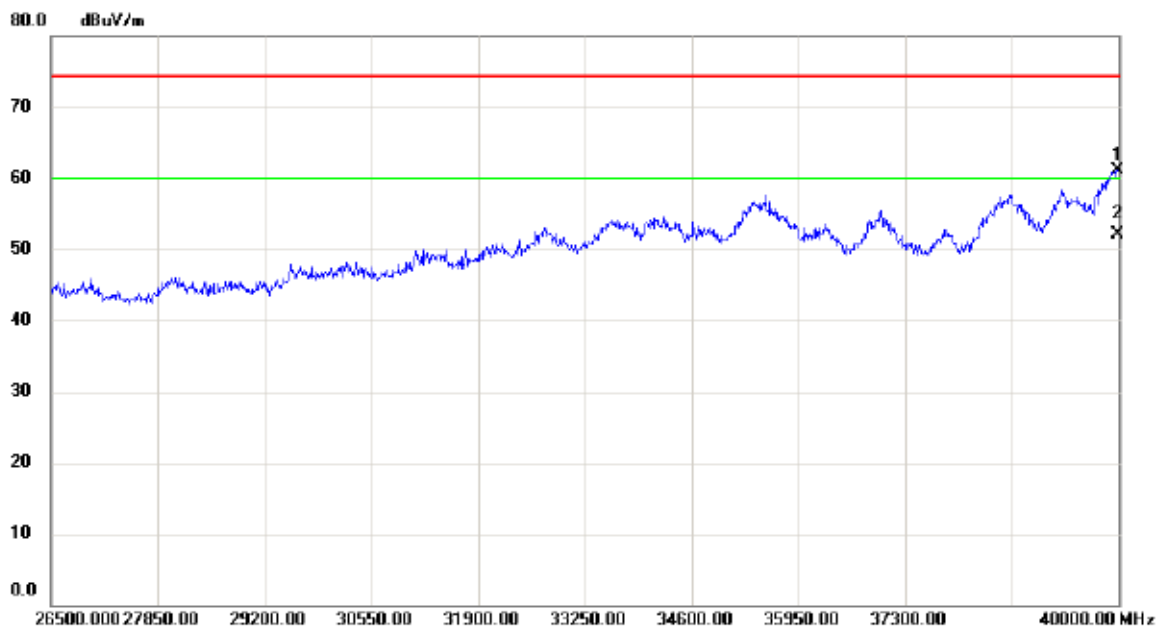

No.	Mk.	Freq.	Reading Level	Correct Factor	Measurement	Limit	Margin	Detector	Comment
		MHz	dBuV	dB	dBuV/m	dBuV/m	dB		
1		39986.50	45.28	15.86	61.14	74.30	-13.16	peak	
2	*	39986.50	36.22	15.86	52.08	60.00	-7.92	AVG	

Orthogonal Axis:	X
Test Mode:	UNII-1/ TX AC(VHT20) Mode 5180MHz

Vertical

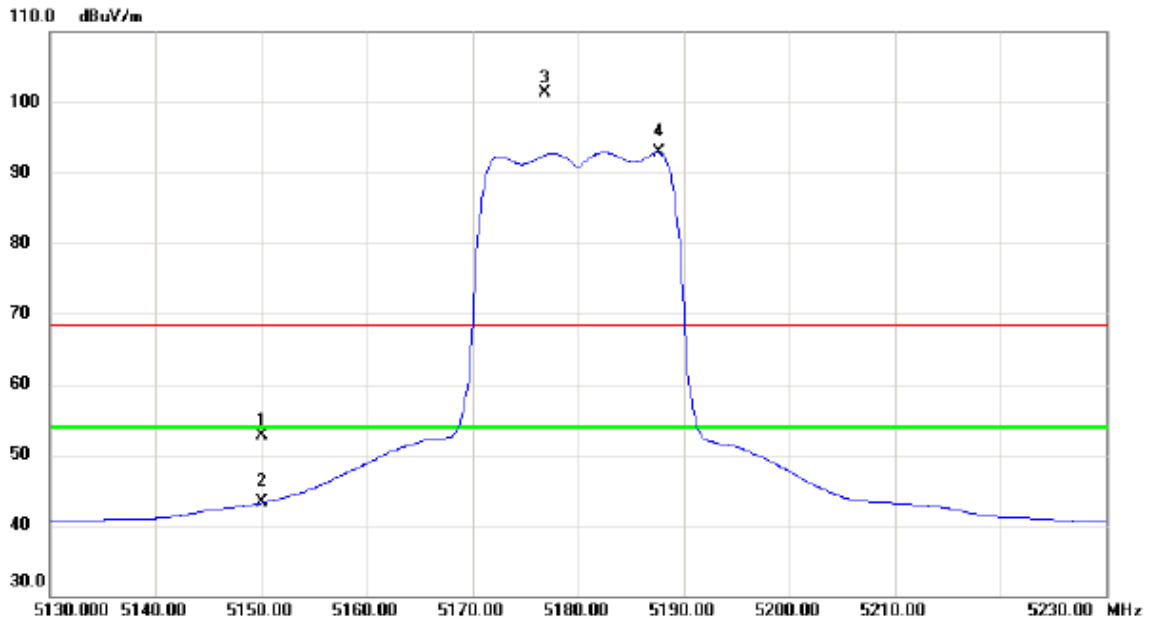

No.	Mk.	Freq. MHz	Reading Level dBuV	Correct Factor dB	Measure- ment dBuV/m	Limit dBuV/m	Margin dB	Detector	Comment
1		5150.000	12.15	40.63	52.78	68.30	-15.52	peak	
2		5150.000	2.58	40.63	43.21	54.00	-10.79	AVG	
3	X	5176.800	60.58	40.71	101.29	68.30	32.99	peak	No Limit
4	*	5187.600	52.08	40.75	92.83	54.00	38.83	AVG	No Limit

Orthogonal Axis:	X
Test Mode:	UNII-1/ TX AC(VHT20) Mode 5180MHz

Vertical

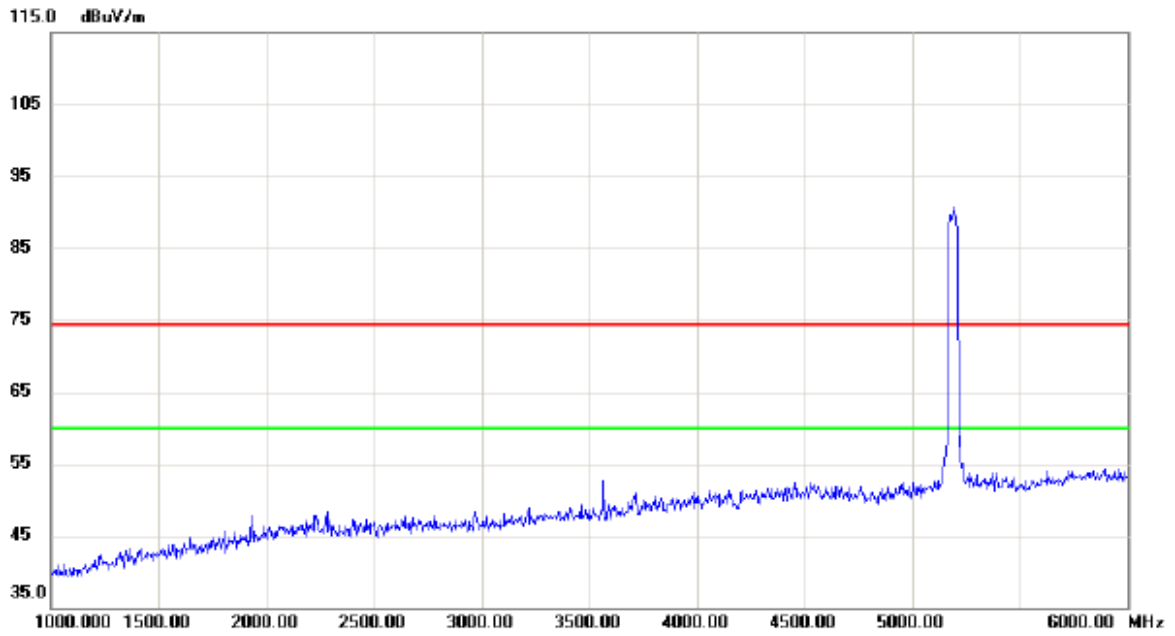

No.	Mk.	Freq.	Reading Level	Correct Factor	Measurement	Limit	Margin	Detector	Comment
		MHz	dBuV	dB	dBuV/m	dBuV/m	dB		

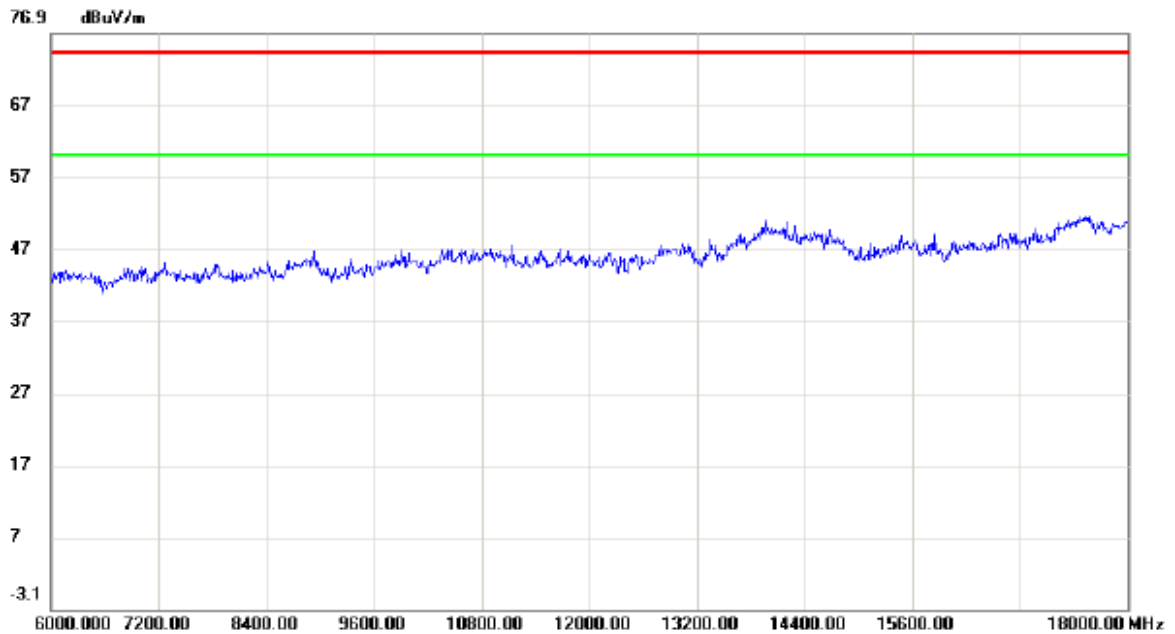

No.	Mk.	Freq.	Reading Level	Correct Factor	Measurement	Limit	Margin	Detector	Comment
		MHz	dBuV	dB	dBuV/m	dBuV/m	dB		

Orthogonal Axis:	X
Test Mode:	UNII-1/ TX AC(VHT20) Mode 5180MHz

Vertical

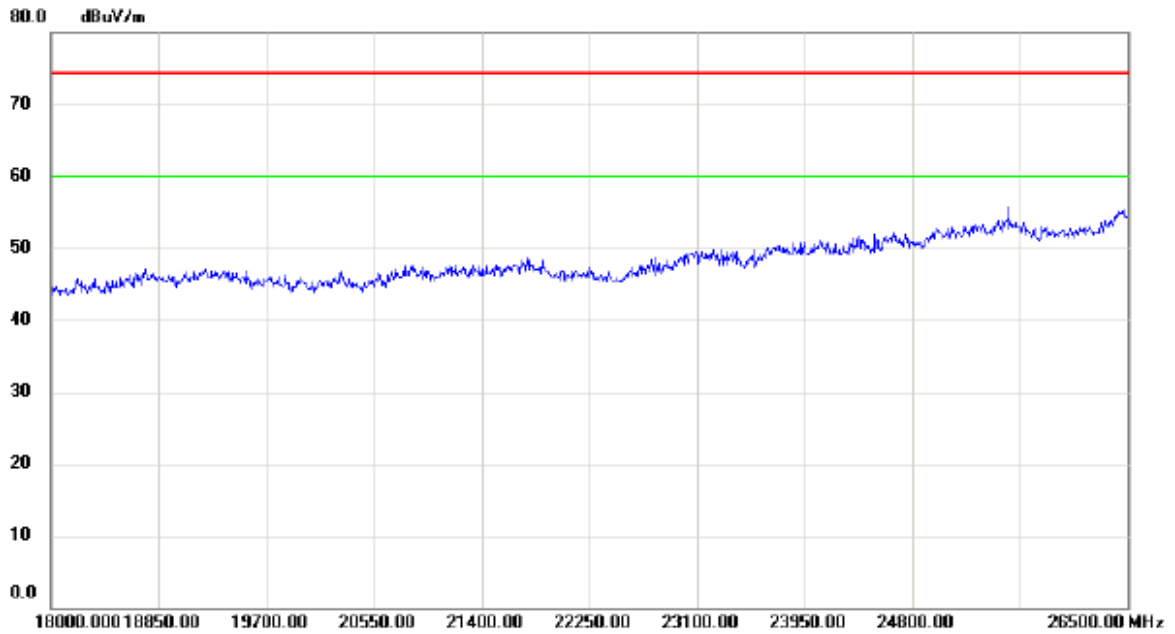

No.	Mk.	Freq.	Reading Level	Correct Factor	Measurement	Limit	Margin	Detector	Comment
		MHz	dBuV	dB	dBuV/m	dBuV/m	dB		

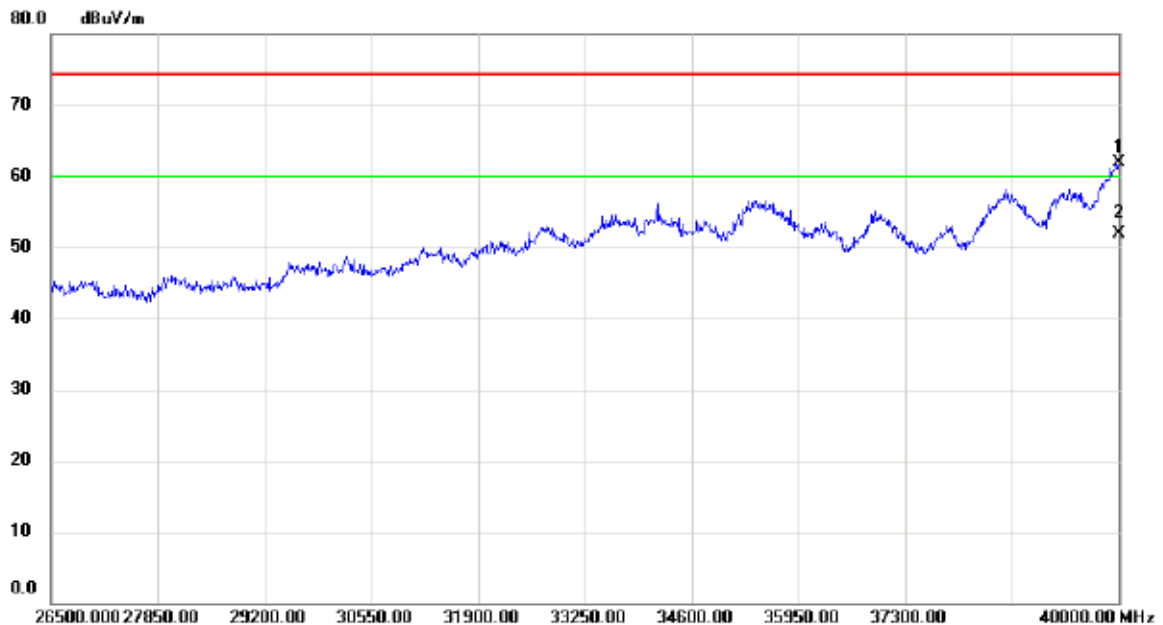

No.	Mk.	Freq.	Reading Level	Correct Factor	Measurement	Limit	Margin	Detector	Comment
		MHz	dBuV	dB	dBuV/m	dBuV/m	dB		
1		40000.00	46.00	15.89	61.89	74.30	-12.41	peak	
2	*	40000.00	36.03	15.89	51.92	60.00	-8.08	AVG	

Orthogonal Axis:	X
Test Mode:	UNII-1/ TX AC(VHT20) Mode 5180MHz

Horizontal

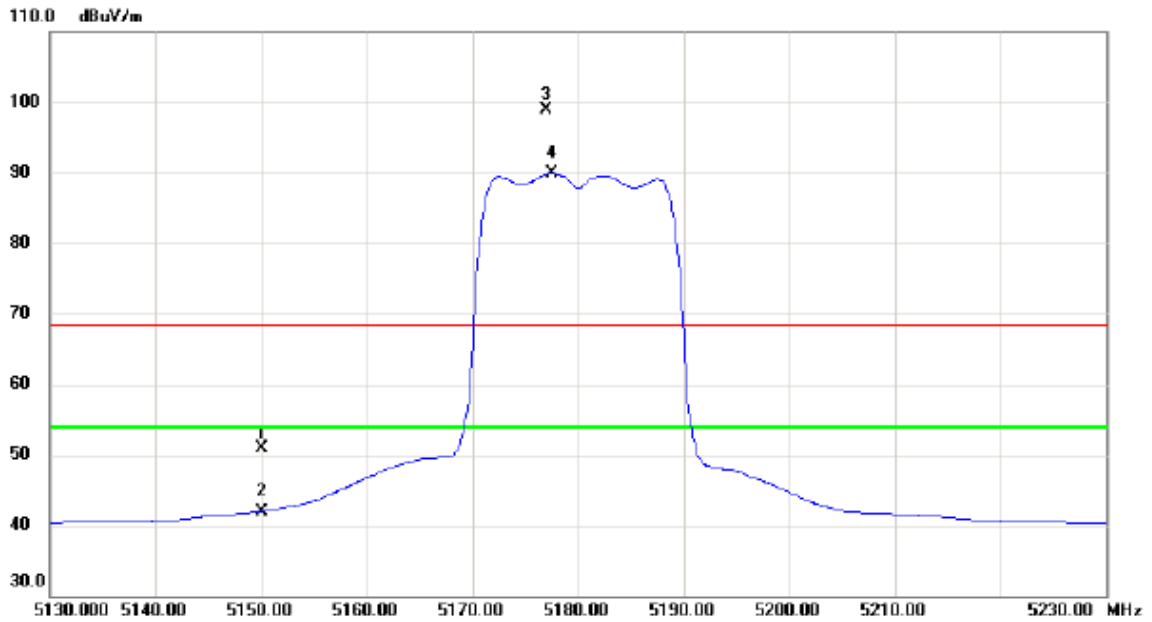

No.	Mk.	Freq.	Reading Level	Correct Factor	Measurement	Limit	Margin	Detector	Comment
		MHz	dBuV	dB	dBuV/m	dBuV/m	dB		
1		5150.000	10.35	40.63	50.98	68.30	-17.32	peak	
2		5150.000	1.37	40.63	42.00	54.00	-12.00	AVG	
3	X	5177.000	58.17	40.71	98.88	68.30	30.58	peak	No Limit
4	*	5177.500	49.13	40.72	89.85	54.00	35.85	AVG	No Limit

Orthogonal Axis:	X
Test Mode:	UNII-1/ TX AC(VHT20) Mode 5180MHz

Horizontal

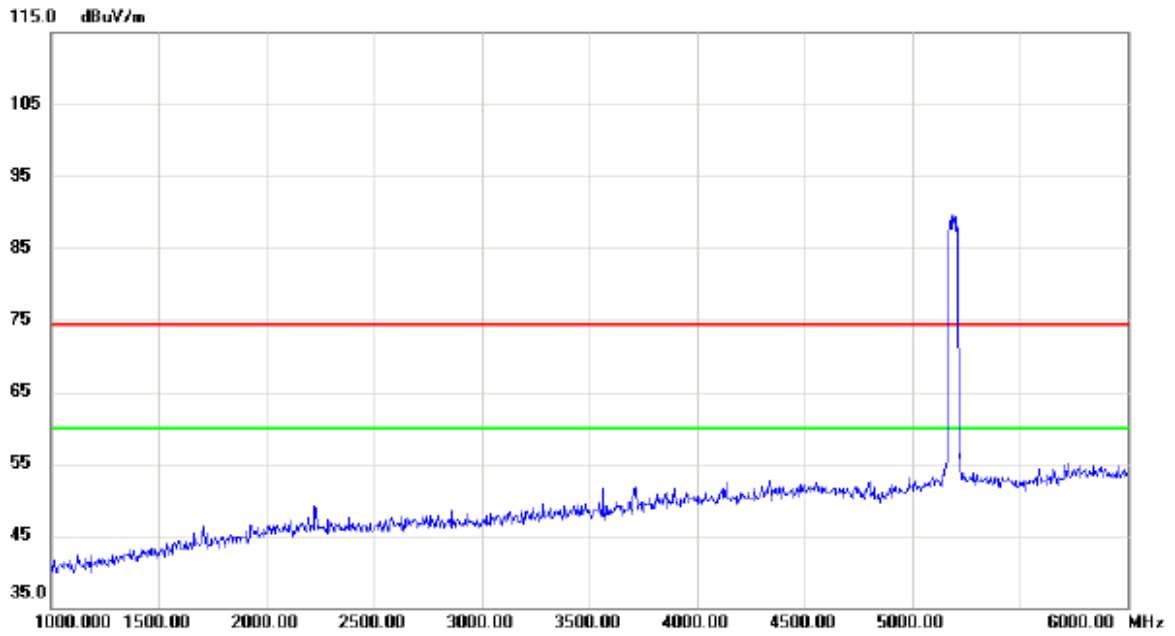

No.	Mk.	Freq.	Reading Level	Correct Factor	Measurement	Limit	Margin	Detector	Comment
		MHz	dBuV	dB	dBuV/m	dBuV/m	dB		

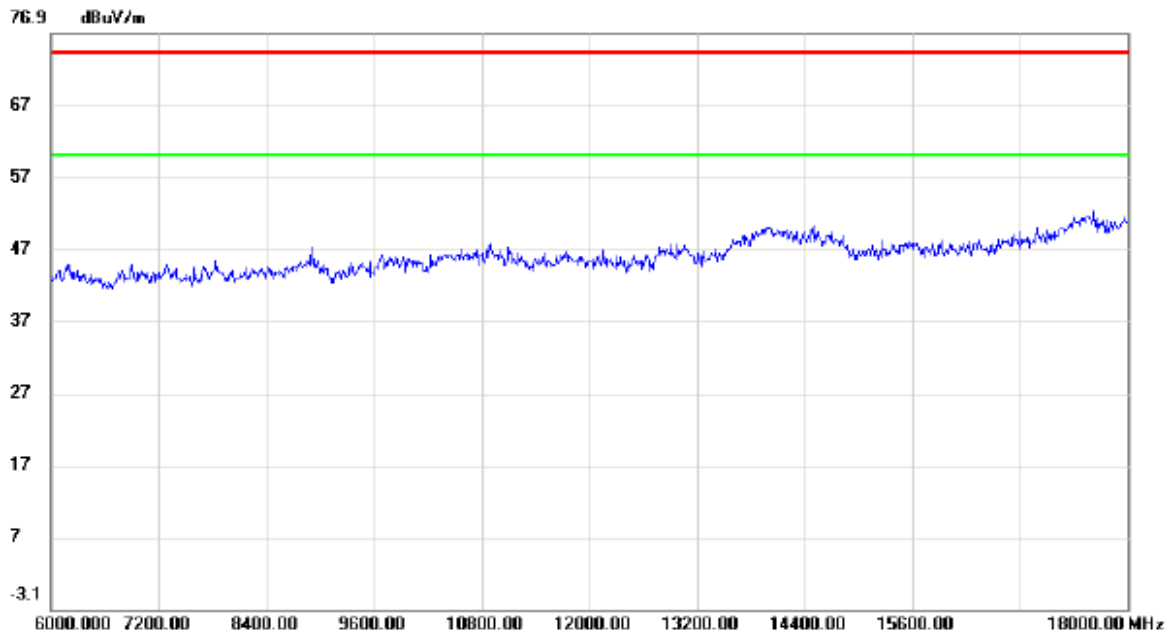

No.	Mk.	Freq.	Reading Level	Correct Factor	Measurement	Limit	Margin	Detector	Comment
		MHz	dBuV	dB	dBuV/m	dBuV/m	dB		

Orthogonal Axis:	X
Test Mode:	UNII-1/ TX AC(VHT20) Mode 5180MHz

Horizontal

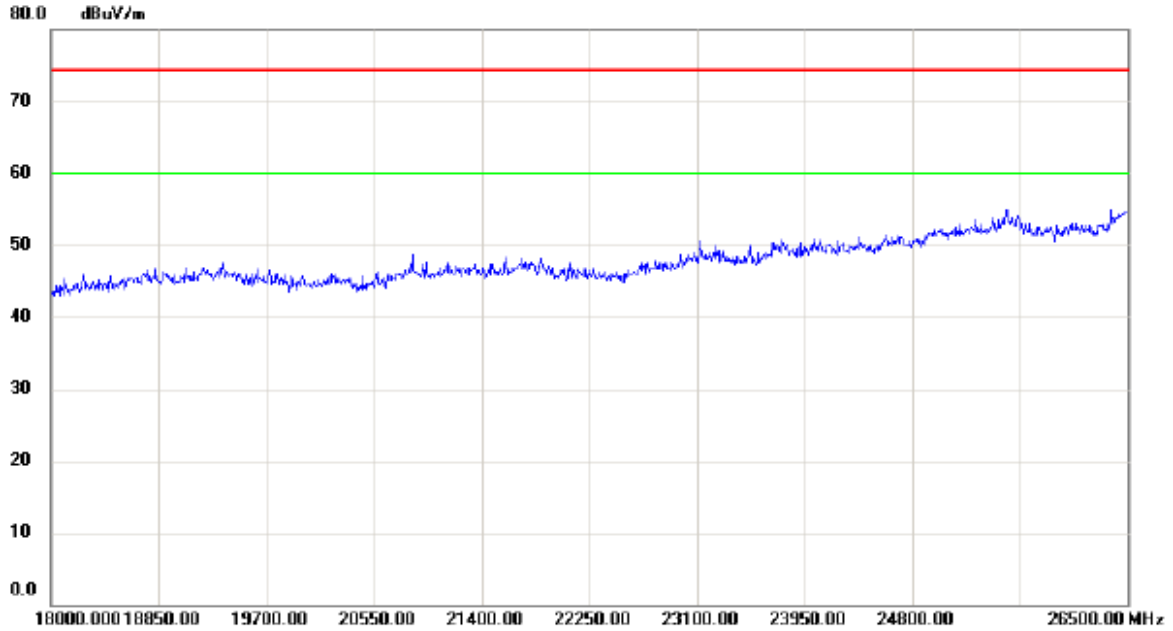

No.	Mk.	Freq.	Reading Level	Correct Factor	Measurement	Limit	Margin	Detector	Comment
		MHz	dBuV	dB	dBuV/m	dBuV/m	dB		

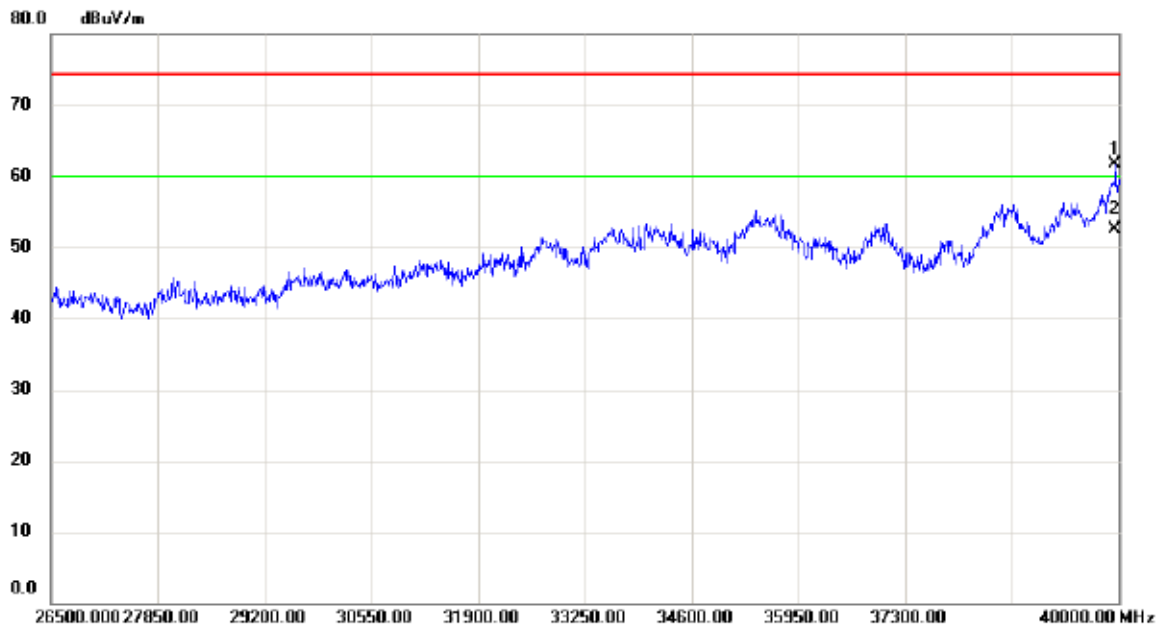

No.	Mk.	Freq.	Reading Level	Correct Factor	Measurement	Limit	Margin	Detector	Comment
		MHz	dBuV	dB	dBuV/m	dBuV/m	dB		
1		39959.50	45.86	15.82	61.68	74.30	-12.62	peak	
2	*	39959.34	36.68	15.82	52.50	60.00	-7.50	AVG	

Orthogonal Axis:	X
Test Mode:	UNII-1/ TX AC(VHT20) Mode 5240MHz

Vertical

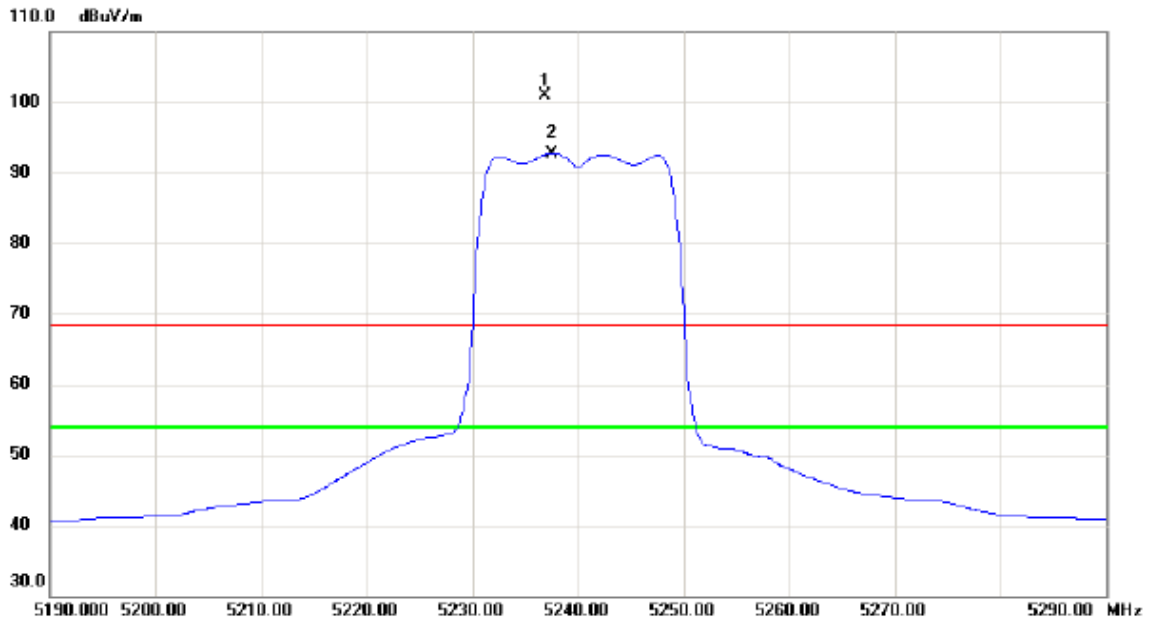

No.	Mk.	Freq.	Reading Level	Correct Factor	Measurement	Limit	Margin	Detector	Comment
		MHz	dBuV	dB	dBuV/m	dBuV/m	dB		
1	X	5236.800	59.91	40.91	100.82	68.30	32.52	peak	No Limit
2	*	5237.500	51.84	40.91	92.75	54.00	38.75	AVG	No Limit

Orthogonal Axis:	X
Test Mode:	UNII-1/ TX AC(VHT20) Mode 5240MHz

Vertical

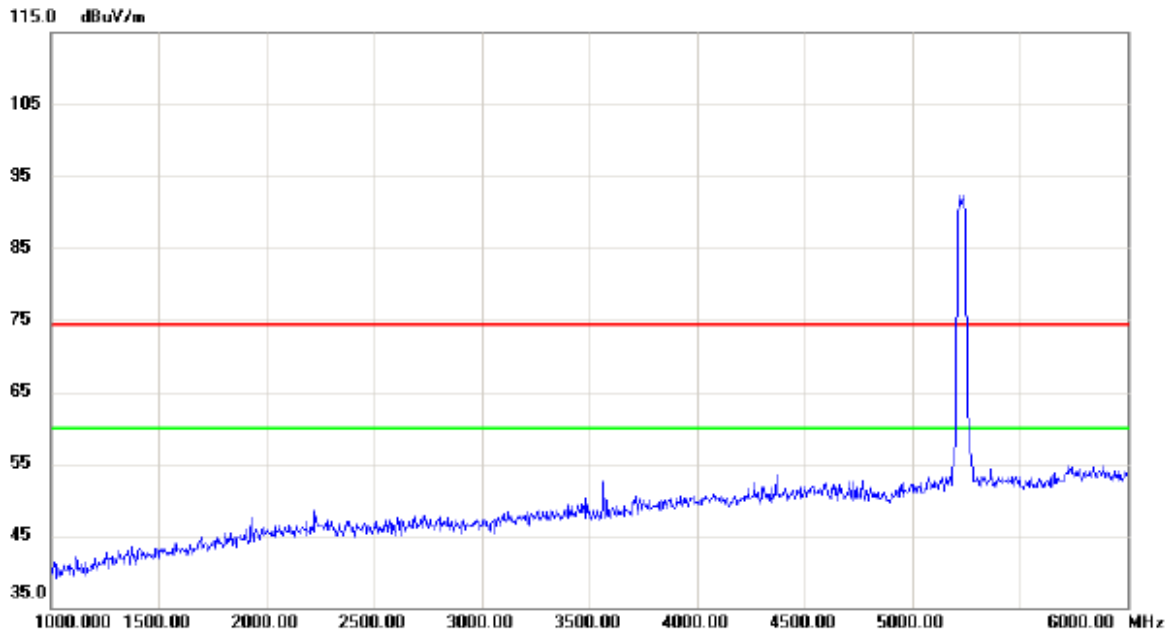

No.	Mk.	Freq.	Reading Level	Correct Factor	Measurement	Limit	Margin	Detector	Comment
		MHz	dBuV	dB	dBuV/m	dBuV/m	dB		

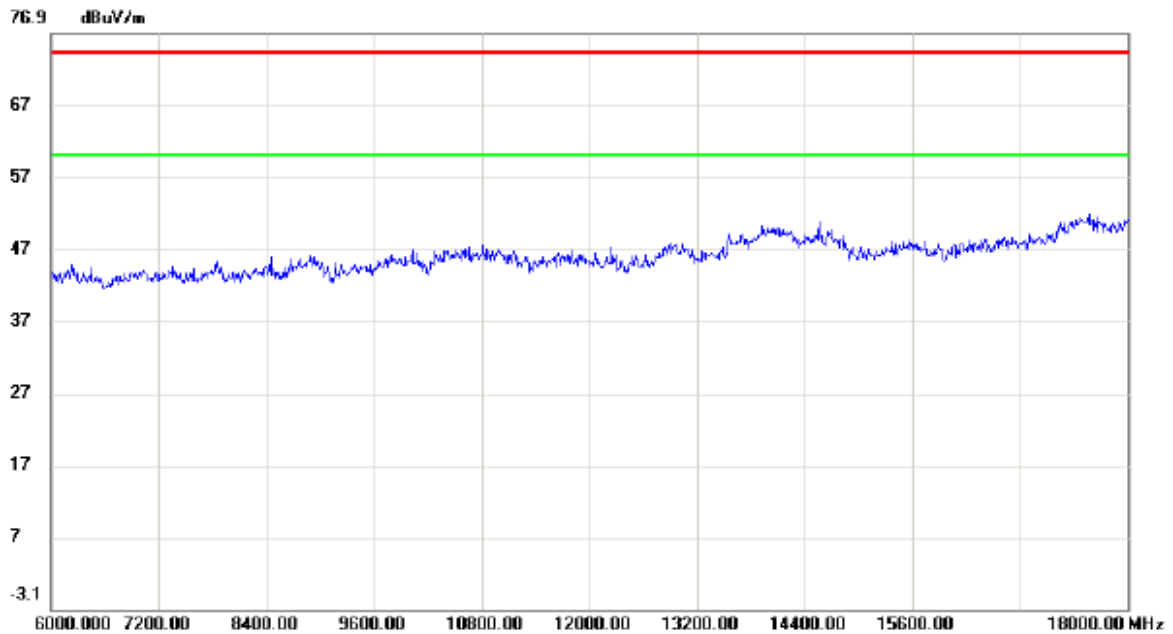

No.	Mk.	Freq.	Reading Level	Correct Factor	Measurement	Limit	Margin	Detector	Comment
		MHz	dBuV	dB	dBuV/m	dBuV/m	dB		

Orthogonal Axis:	X
Test Mode:	UNII-1/ TX AC(VHT20) Mode 5240MHz

Vertical

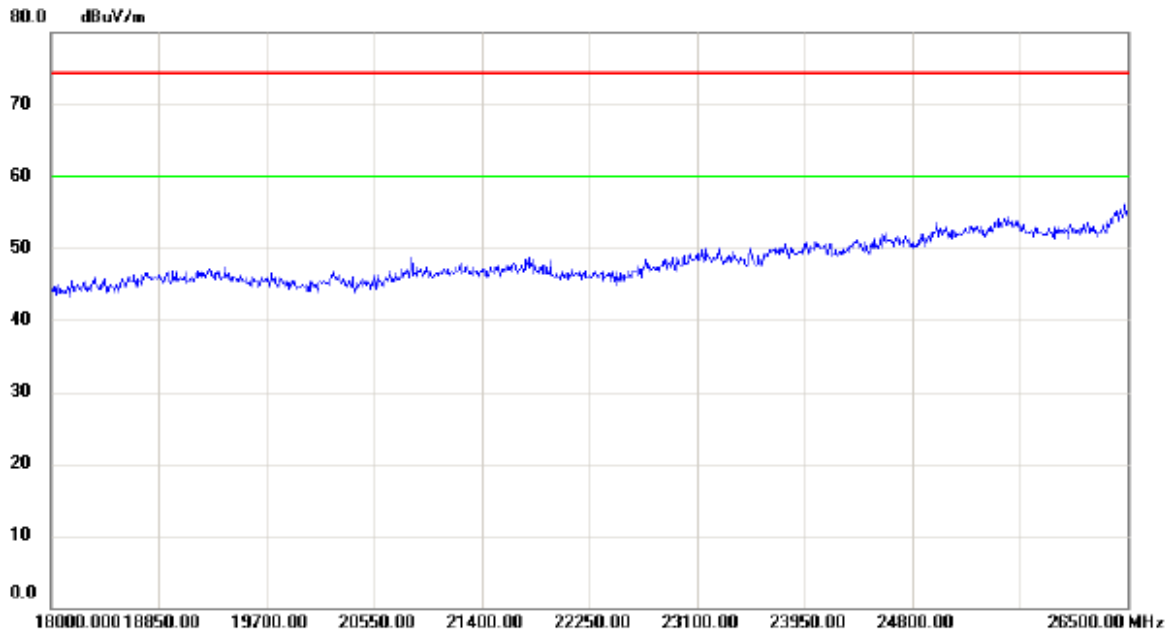

No.	Mk.	Freq.	Reading Level	Correct Factor	Measurement	Limit	Margin	Detector	Comment
		MHz	dBuV	dB	dBuV/m	dBuV/m	dB		

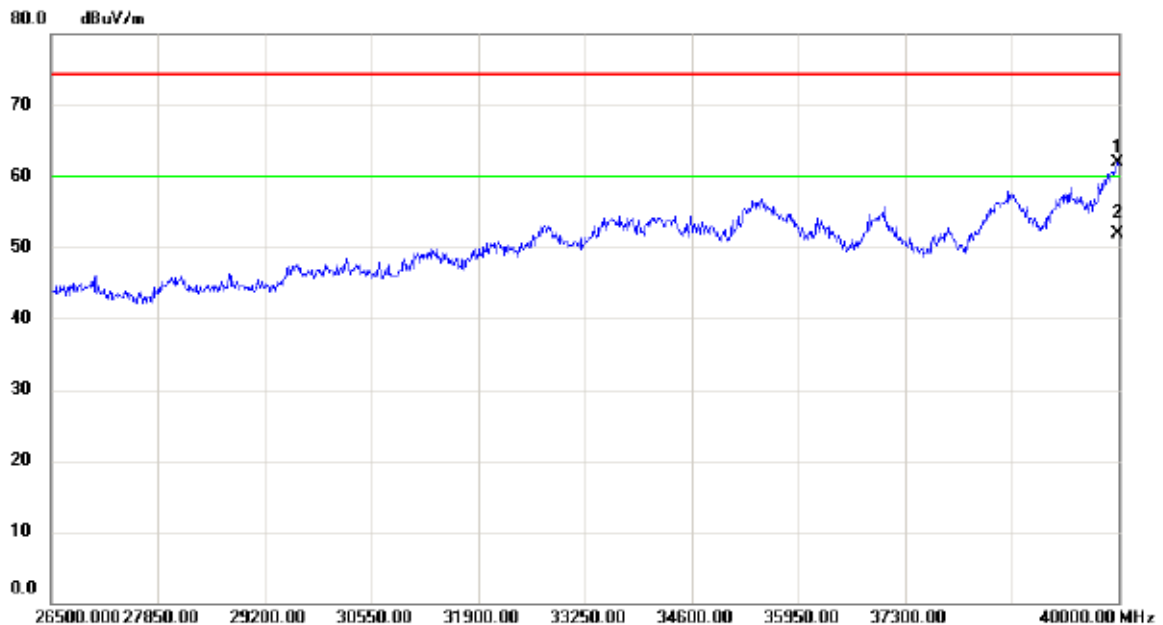

No.	Mk.	Freq.	Reading Level	Correct Factor	Measurement	Limit	Margin	Detector	Comment
		MHz	dBuV	dB	dBuV/m	dBuV/m	dB		
1		39986.50	46.08	15.86	61.94	74.30	-12.36	peak	
2	*	39986.69	36.02	15.86	51.88	60.00	-8.12	AVG	

Orthogonal Axis:	X
Test Mode:	UNII-1/ TX AC(VHT20) Mode 5240MHz

Horizontal

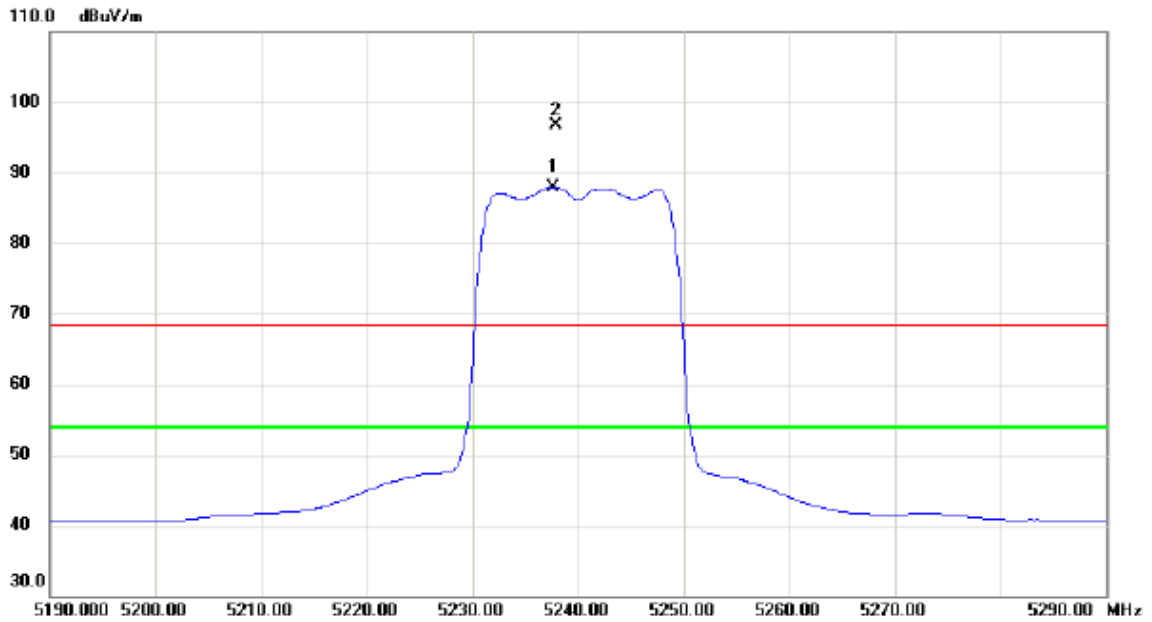

No.	Mk.	Freq.	Reading Level	Correct Factor	Measurement	Limit	Margin	Detector	Comment
		MHz	dBuV	dB	dBuV/m	dBuV/m	dB		
1	*	5237.600	47.02	40.91	87.93	54.00	33.93	AVG	No Limit
2	X	5237.900	55.71	40.91	96.62	68.30	28.32	peak	No Limit

Orthogonal Axis:	X
Test Mode:	UNII-1/ TX AC(VHT20) Mode 5240MHz

Horizontal

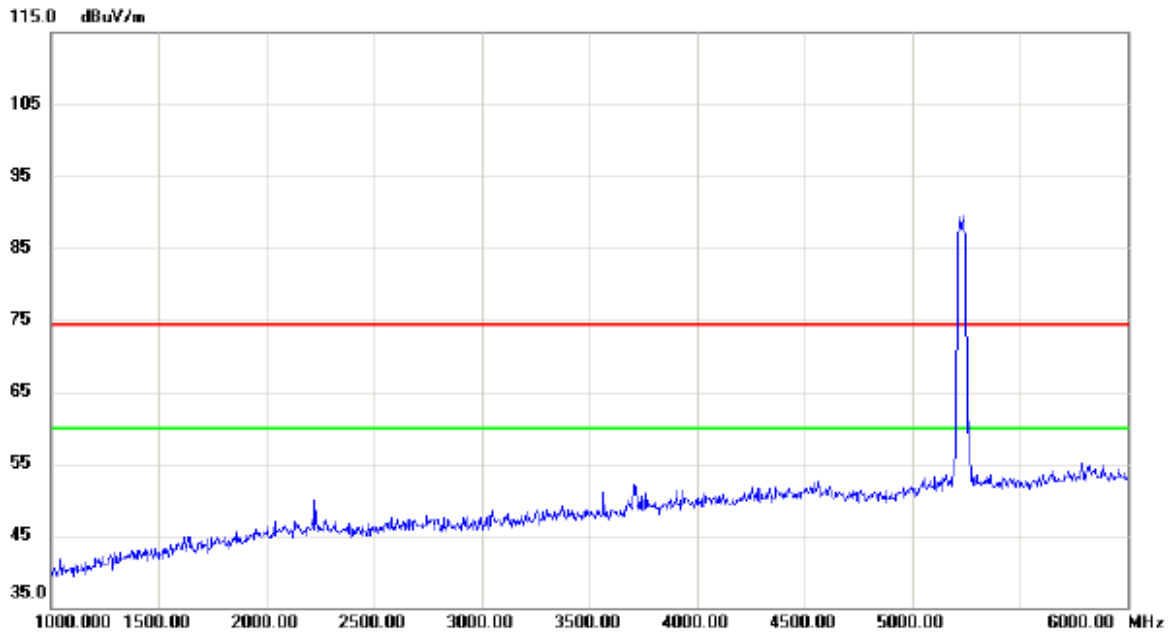

No.	Mk.	Freq.	Reading Level	Correct Factor	Measurement	Limit	Margin	Detector	Comment
		MHz	dBuV	dB	dBuV/m	dBuV/m	dB		

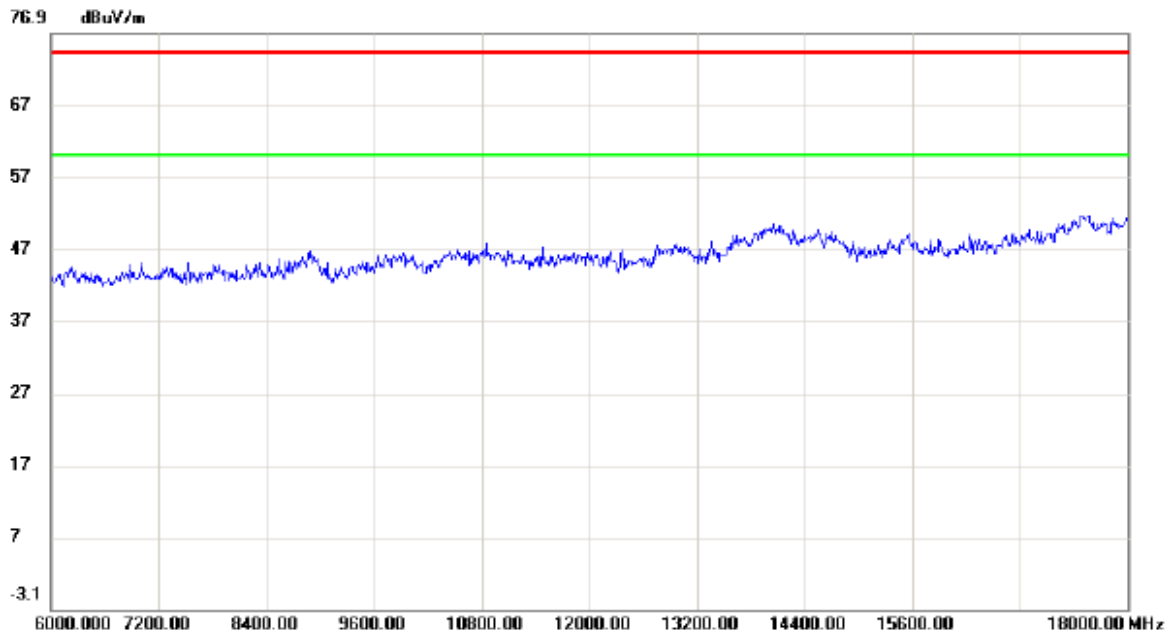

No.	Mk.	Freq.	Reading Level	Correct Factor	Measurement	Limit	Margin	Detector	Comment
		MHz	dBuV	dB	dBuV/m	dBuV/m	dB		

Orthogonal Axis:	X
Test Mode:	UNII-1/ TX AC(VHT20) Mode 5240MHz

Horizontal

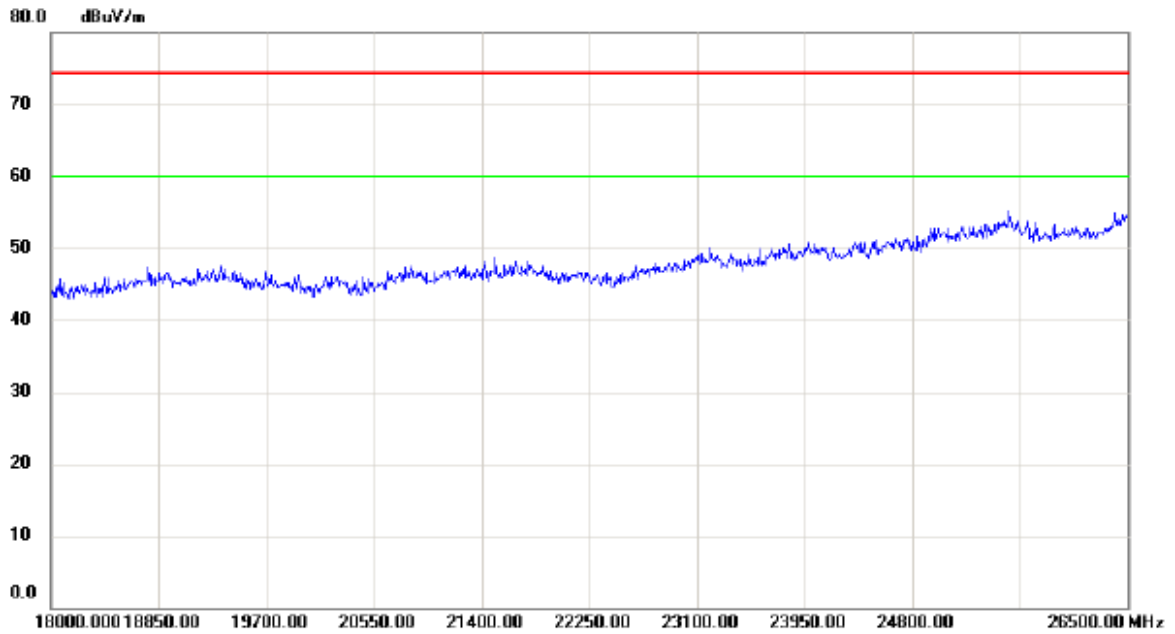

No.	Mk.	Freq.	Reading Level	Correct Factor	Measurement	Limit	Margin	Detector	Comment
		MHz	dBuV	dB	dBuV/m	dBuV/m	dB		

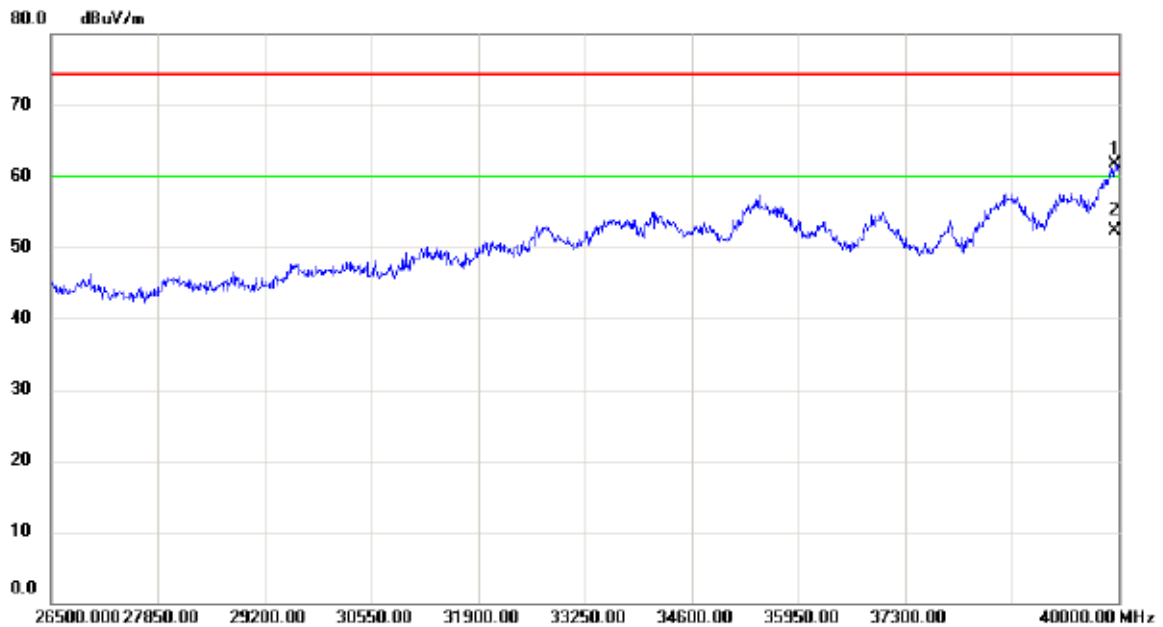

No.	Mk.	Freq.	Reading Level	Correct Factor	Measurement	Limit	Margin	Detector	Comment
		MHz	dBuV	dB	dBuV/m	dBuV/m	dB		
1		39946.00	45.84	15.81	61.65	74.30	-12.65	peak	
2	*	39946.37	36.52	15.81	52.33	60.00	-7.67	AVG	

Orthogonal Axis:	X
Test Mode:	UNII-1/ TX AC(VHT40) Mode 5190MHz

Vertical

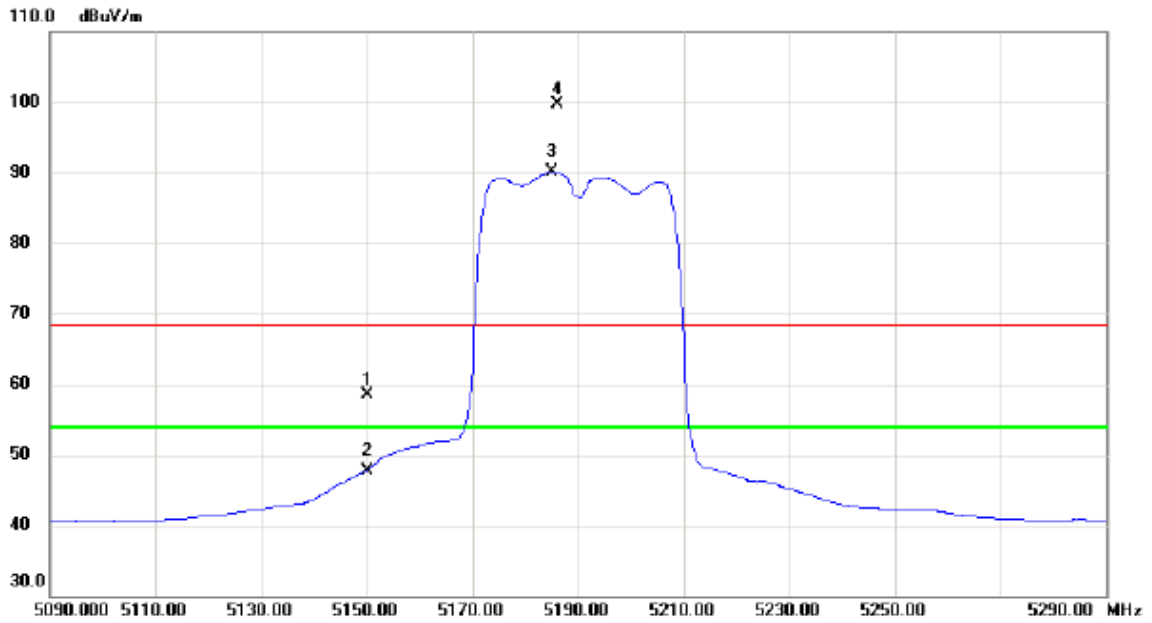

No.	Mk.	Freq. MHz	Reading Level dBuV	Correct Factor dB	Measure- ment dBuV/m	Limit dBuV/m	Margin dB	Detector	Comment
1		5150.000	17.88	40.63	58.51	68.30	-9.79	peak	
2		5150.000	7.16	40.63	47.79	54.00	-6.21	AVG	
3	*	5185.000	49.29	40.74	90.03	54.00	36.03	AVG	No Limit
4	X	5186.000	58.88	40.75	99.63	68.30	31.33	peak	No Limit

Orthogonal Axis:	X
Test Mode:	UNII-1/ TX AC(VHT40) Mode 5190MHz

Vertical

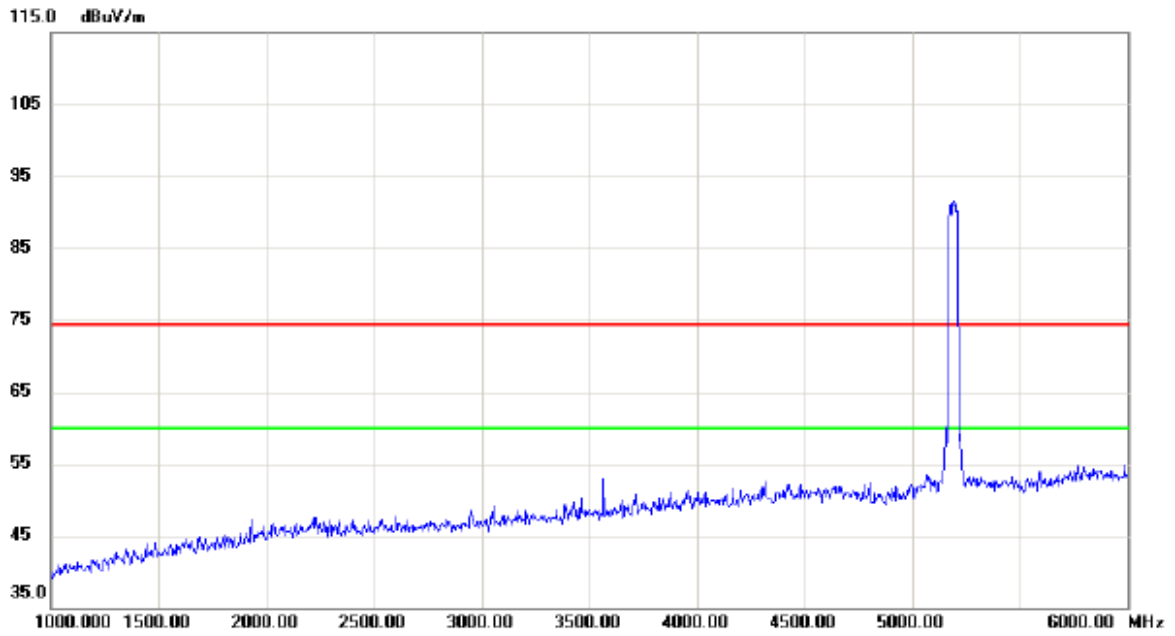

No.	Mk.	Freq.	Reading Level	Correct Factor	Measurement	Limit	Margin	Detector	Comment
		MHz	dBuV	dB	dBuV/m	dBuV/m	dB		

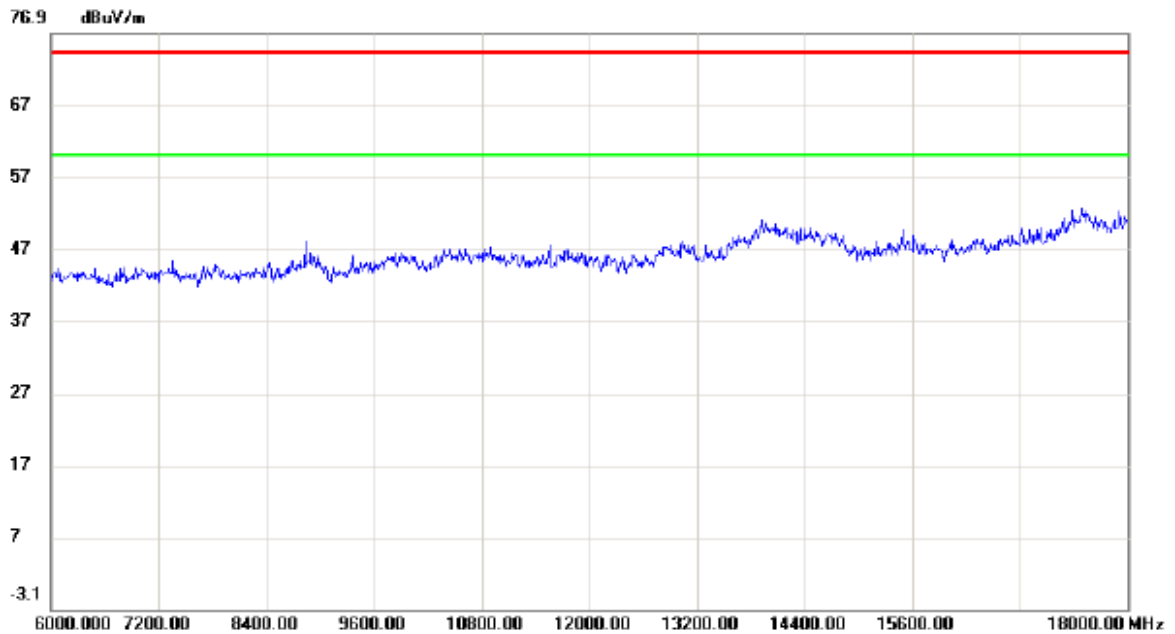

No.	Mk.	Freq.	Reading Level	Correct Factor	Measurement	Limit	Margin	Detector	Comment
		MHz	dBuV	dB	dBuV/m	dBuV/m	dB		

Orthogonal Axis:	X
Test Mode:	UNII-1/ TX AC(VHT40) Mode 5190MHz

Vertical

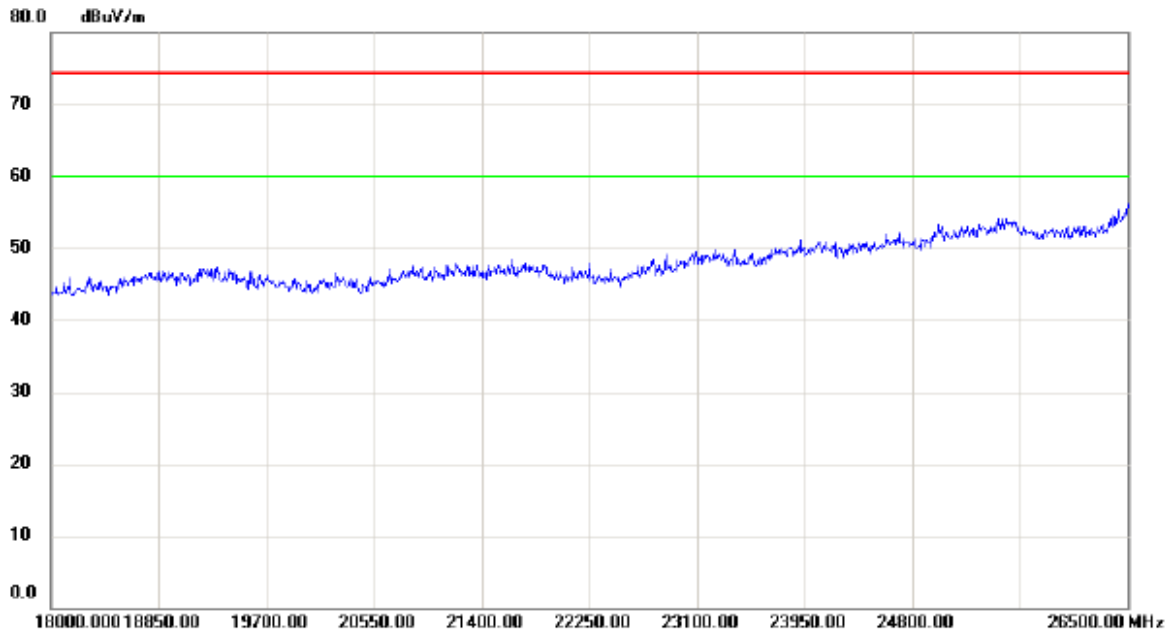

No.	Mk.	Freq.	Reading Level	Correct Factor	Measurement	Limit	Margin	Detector	Comment
		MHz	dBuV	dB	dBuV/m	dBuV/m	dB		

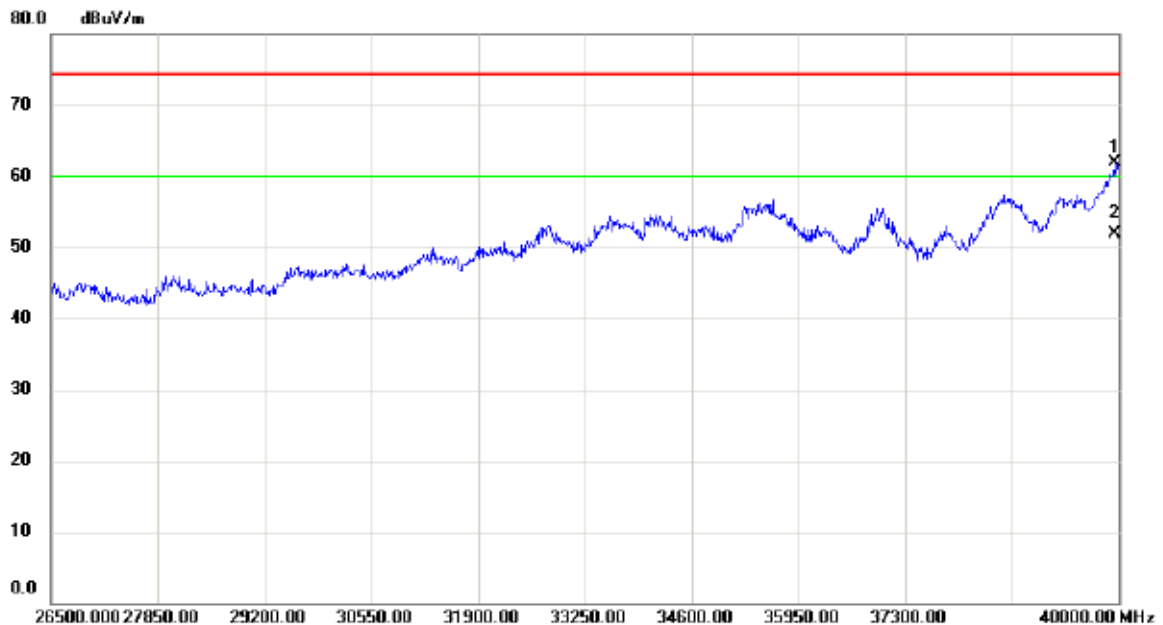

No.	Mk.	Freq.	Reading Level	Correct Factor	Measurement	Limit	Margin	Detector	Comment
		MHz	dBuV	dB	dBuV/m	dBuV/m	dB		
1		39946.00	46.09	15.81	61.90	74.30	-12.40	peak	
2	*	39946.00	36.13	15.81	51.94	60.00	-8.06	AVG	

Orthogonal Axis:	X
Test Mode:	UNII-1/ TX AC(VHT40) Mode 5190MHz

Horizontal

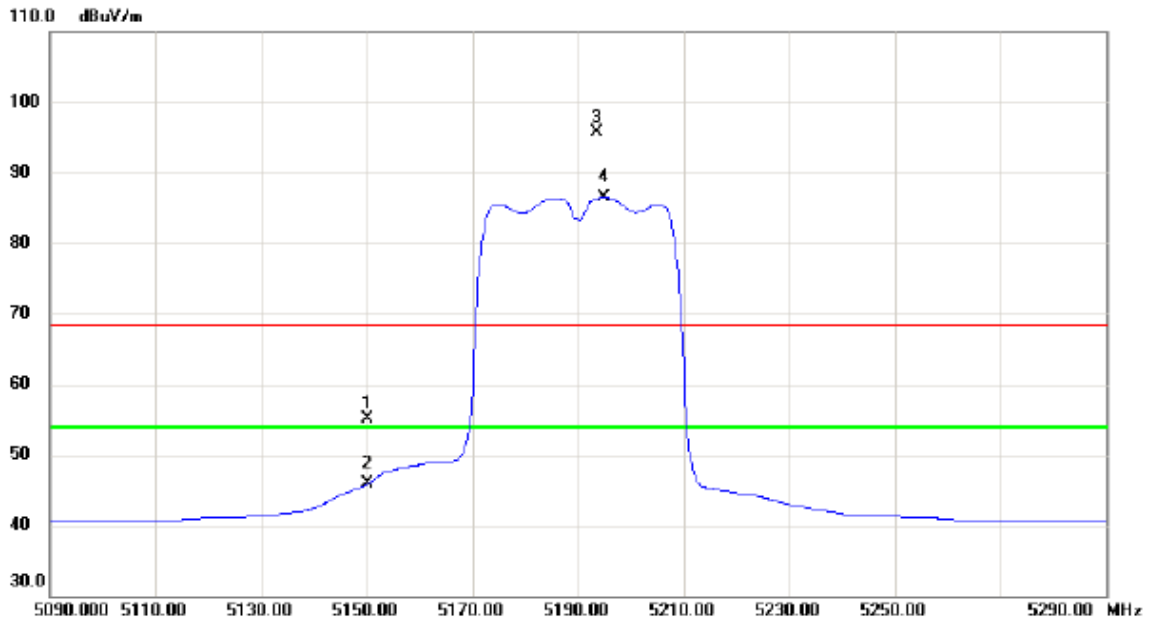

No.	Mk.	Freq. MHz	Reading Level dBuV	Correct Factor dB	Measure- ment dBuV/m	Limit dBuV/m	Margin dB	Detector	Comment
1		5150.000	14.40	40.63	55.03	68.30	-13.27	peak	
2		5150.000	5.19	40.63	45.82	54.00	-8.18	AVG	
3	X	5193.600	54.95	40.76	95.71	68.30	27.41	peak	No Limit
4	*	5195.000	45.70	40.78	86.48	54.00	32.48	AVG	No Limit

Orthogonal Axis:	X
Test Mode:	UNII-1/ TX AC(VHT40) Mode 5190MHz

Horizontal

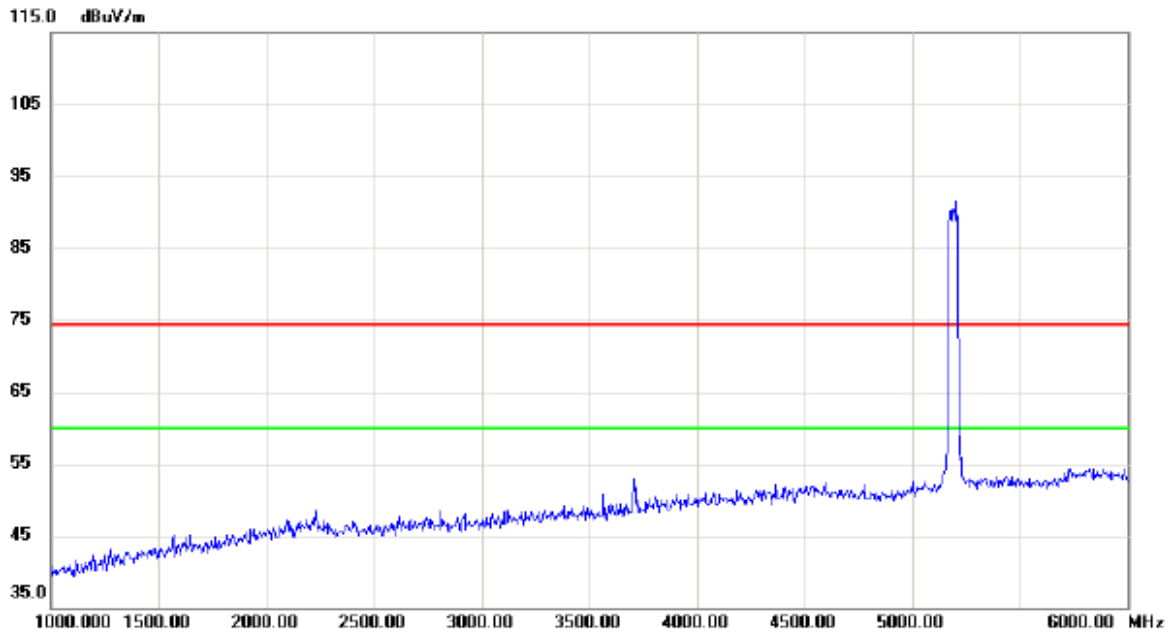

No.	Mk.	Freq.	Reading Level	Correct Factor	Measurement	Limit	Margin	Detector	Comment
		MHz	dBuV	dB	dBuV/m	dBuV/m	dB		

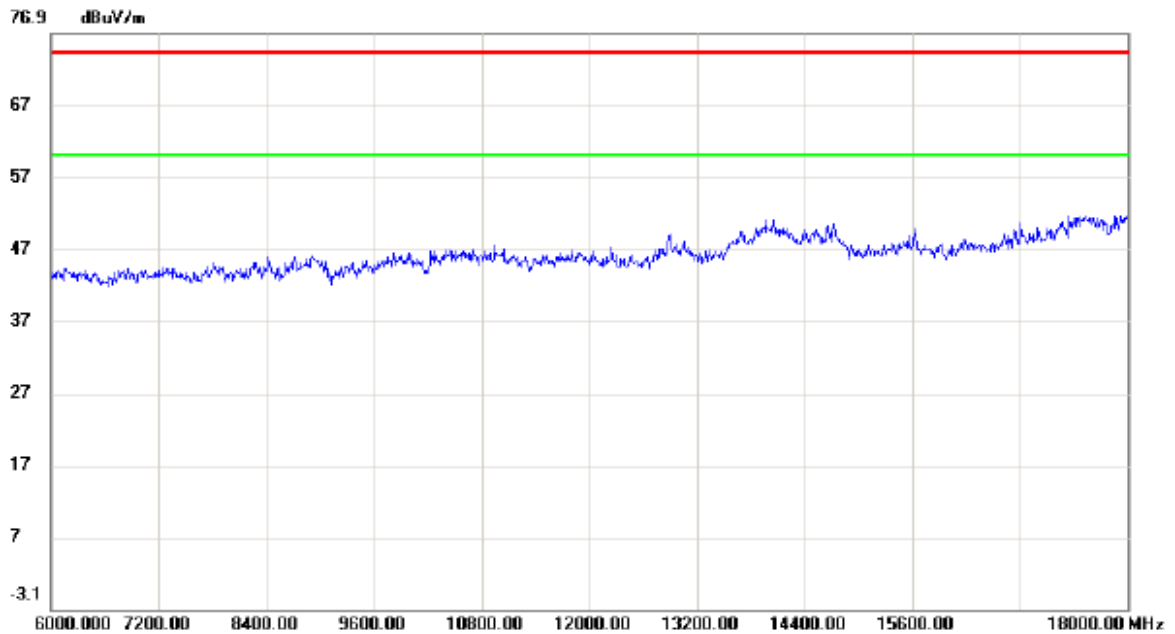

No.	Mk.	Freq.	Reading Level	Correct Factor	Measurement	Limit	Margin	Detector	Comment
		MHz	dBuV	dB	dBuV/m	dBuV/m	dB		

Orthogonal Axis:	X
Test Mode:	UNII-1/ TX AC(VHT40) Mode 5190MHz

Horizontal

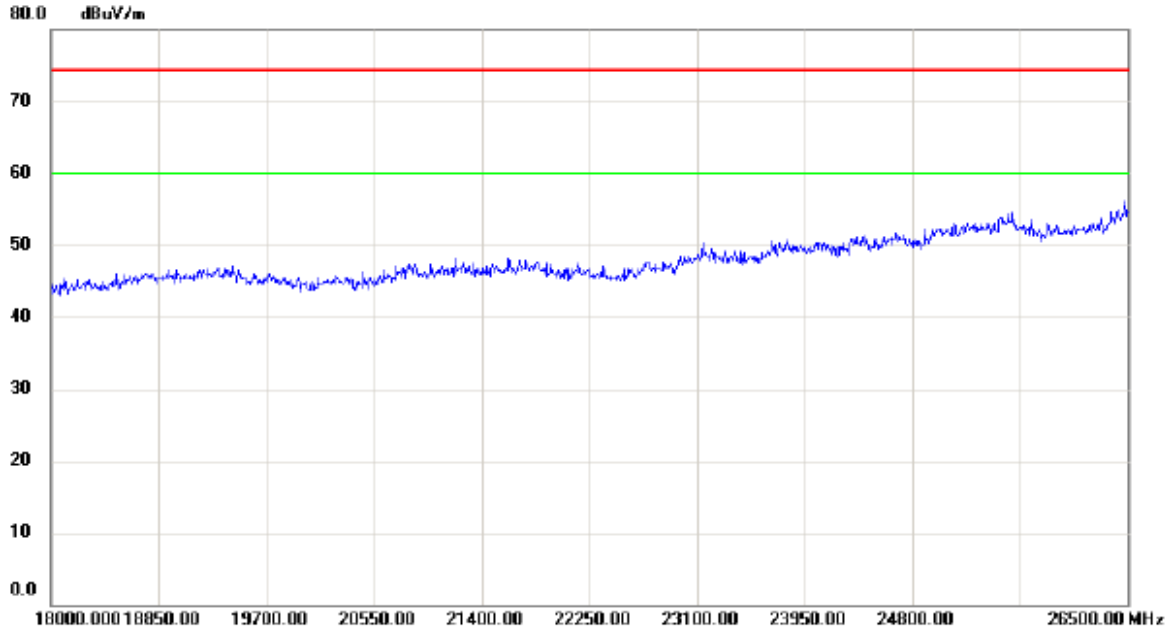

No.	Mk.	Freq.	Reading Level	Correct Factor	Measurement	Limit	Margin	Detector	Comment
		MHz	dBuV	dB	dBuV/m	dBuV/m	dB		

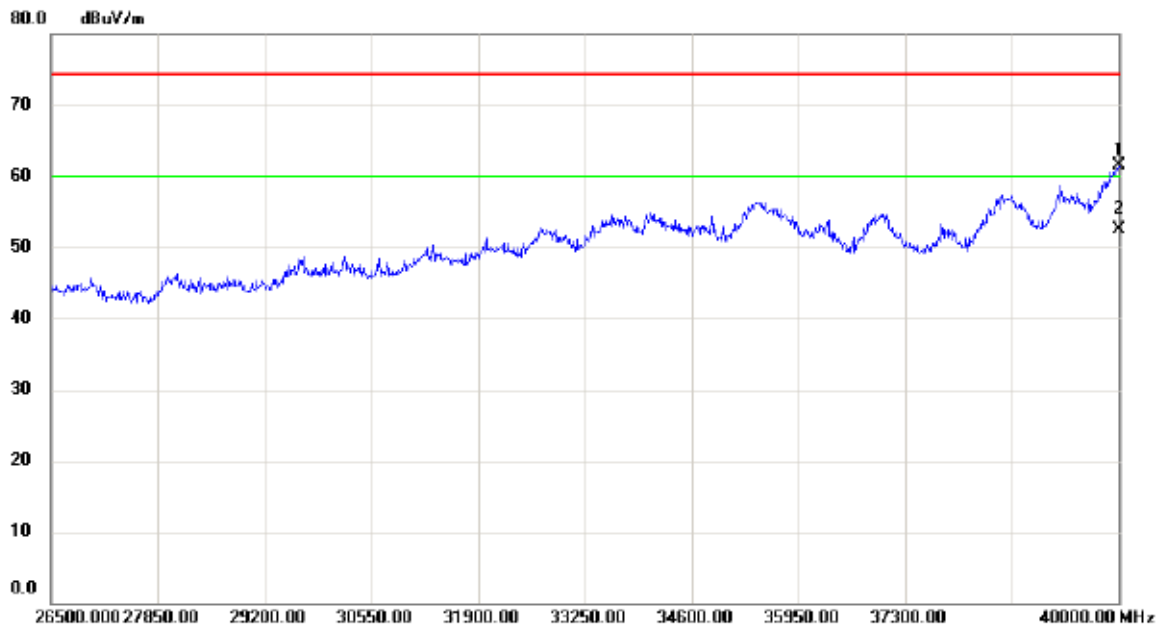

No.	Mk.	Freq.	Reading Level	Correct Factor	Measurement	Limit	Margin	Detector	Comment
		MHz	dBuV	dB	dBuV/m	dBuV/m	dB		
1		40000.00	45.67	15.89	61.56	74.30	-12.74	peak	
2	*	40000.00	36.63	15.89	52.52	60.00	-7.48	AVG	

Orthogonal Axis:	X
Test Mode:	UNII-1/ TX AC(VHT40) Mode 5230MHz

Vertical

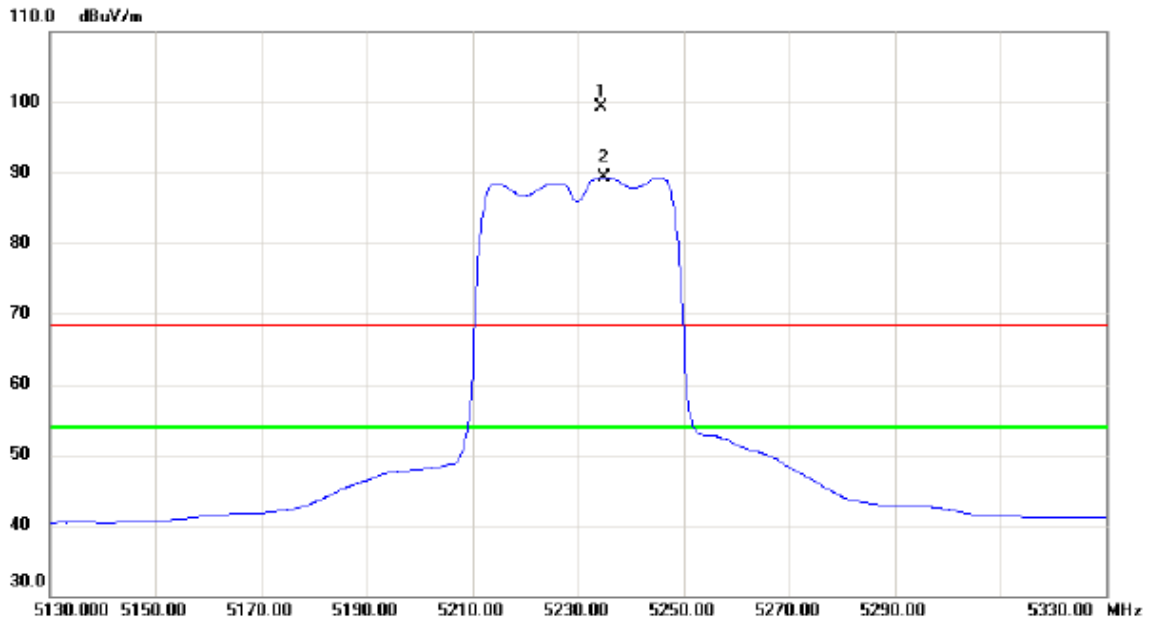

No.	Mk.	Freq.	Reading Level	Correct Factor	Measurement	Limit	Margin	Detector	Comment
		MHz	dBuV	dB	dBuV/m	dBuV/m	dB		
1	X	5234.400	58.39	40.90	99.29	68.30	30.99	peak	No Limit
2	*	5235.000	48.43	40.90	89.33	54.00	35.33	AVG	No Limit

Orthogonal Axis:	X
Test Mode:	UNII-1/ TX AC(VHT40) Mode 5230MHz

Vertical

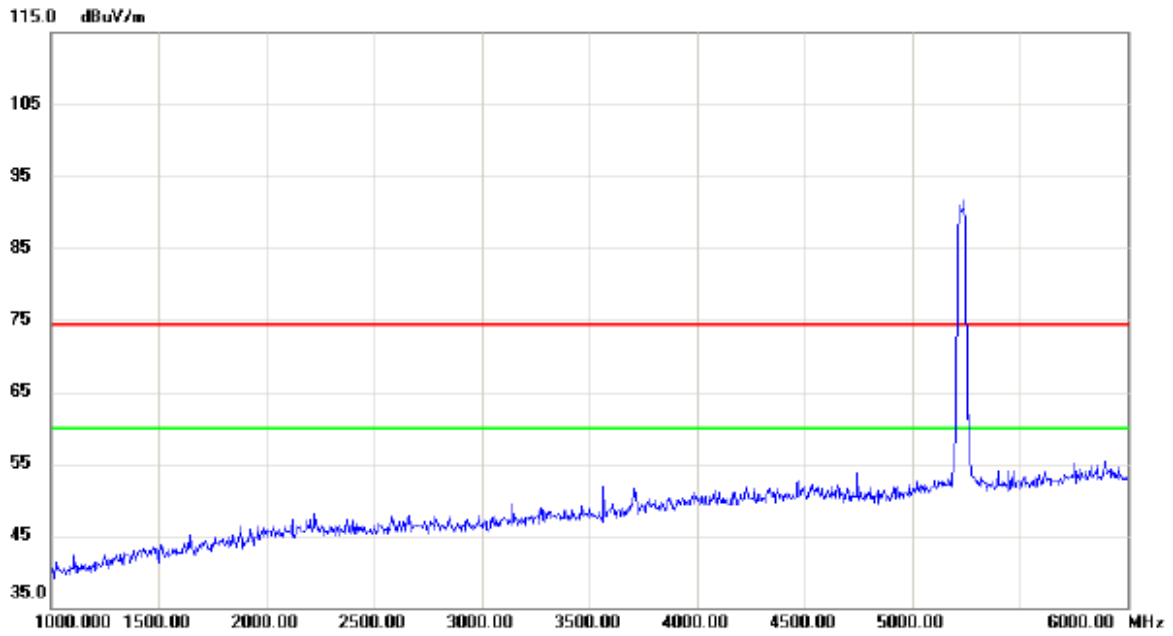

No.	Mk.	Freq.	Reading Level	Correct Factor	Measurement	Limit	Margin	Detector	Comment
		MHz	dBuV	dB	dBuV/m	dBuV/m	dB		

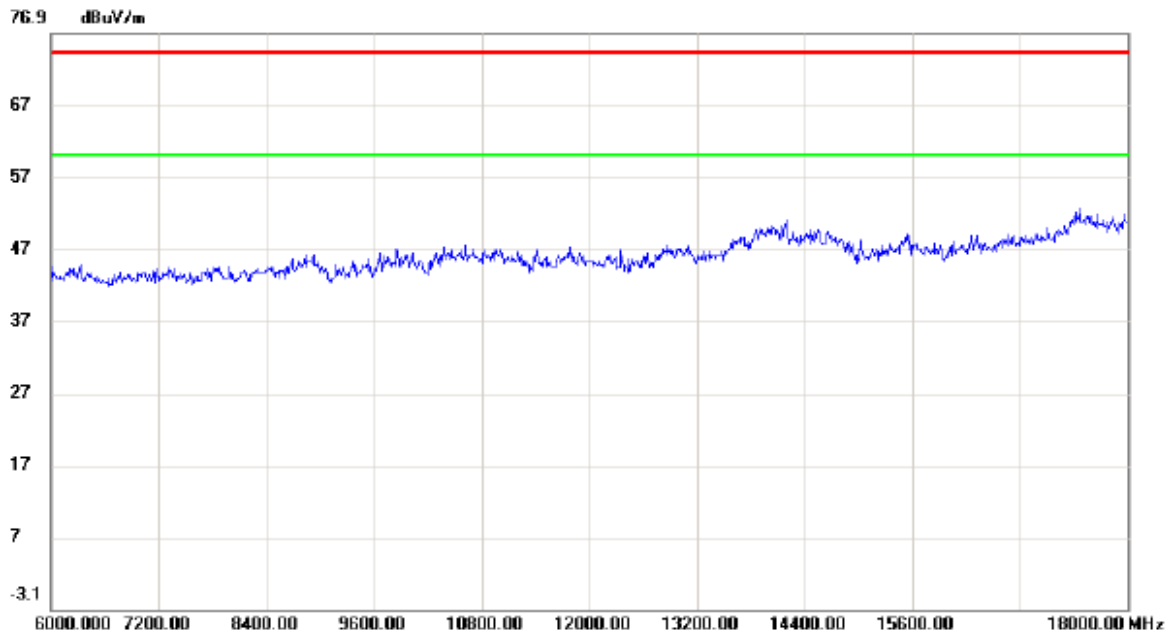

No.	Mk.	Freq.	Reading Level	Correct Factor	Measurement	Limit	Margin	Detector	Comment
		MHz	dBuV	dB	dBuV/m	dBuV/m	dB		

Orthogonal Axis:	X
Test Mode:	UNII-1/ TX AC(VHT40) Mode 5230MHz

Vertical

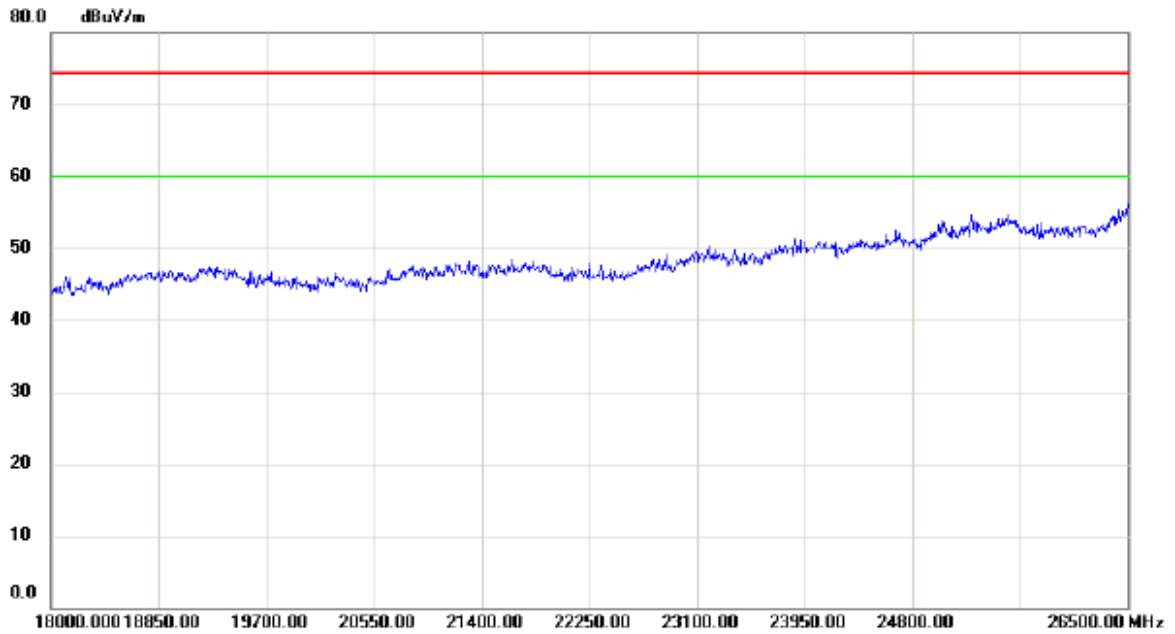

No.	Mk.	Freq.	Reading Level	Correct Factor	Measurement	Limit	Margin	Detector	Comment
		MHz	dBuV	dB	dBuV/m	dBuV/m	dB		

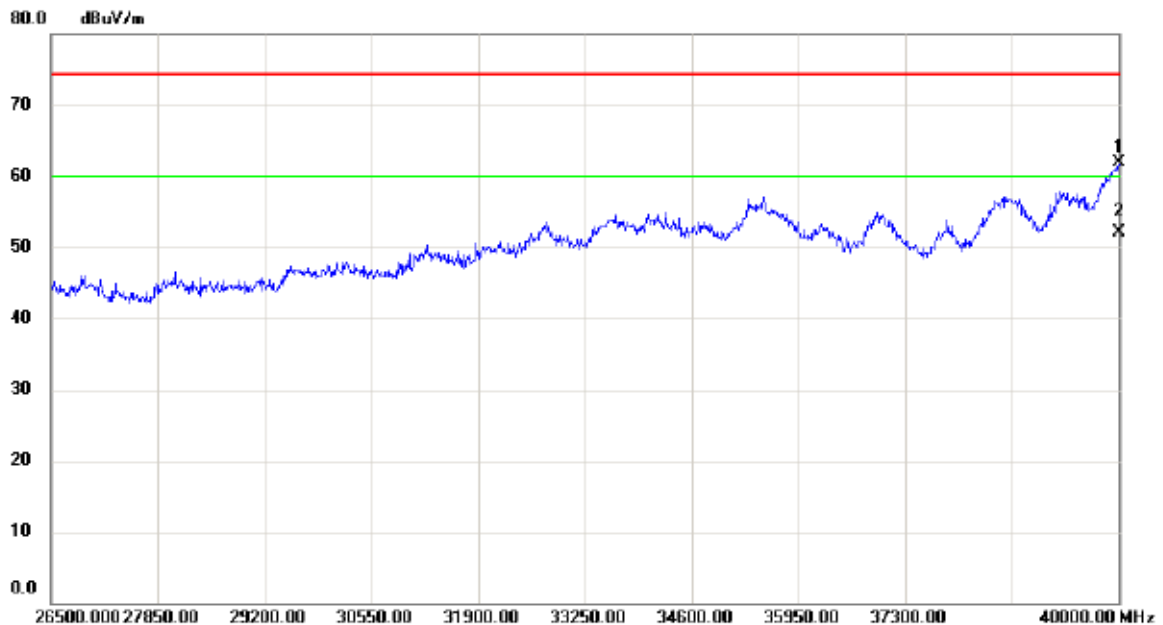

No.	Mk.	Freq.	Reading Level	Correct Factor	Measurement	Limit	Margin	Detector	Comment
		MHz	dBuV	dB	dBuV/m	dBuV/m	dB		
1		40000.00	46.08	15.89	61.97	74.30	-12.33	peak	
2	*	40000.00	36.24	15.89	52.13	60.00	-7.87	AVG	

Orthogonal Axis:	X
Test Mode:	UNII-1/ TX AC(VHT40) Mode 5230MHz

Horizontal

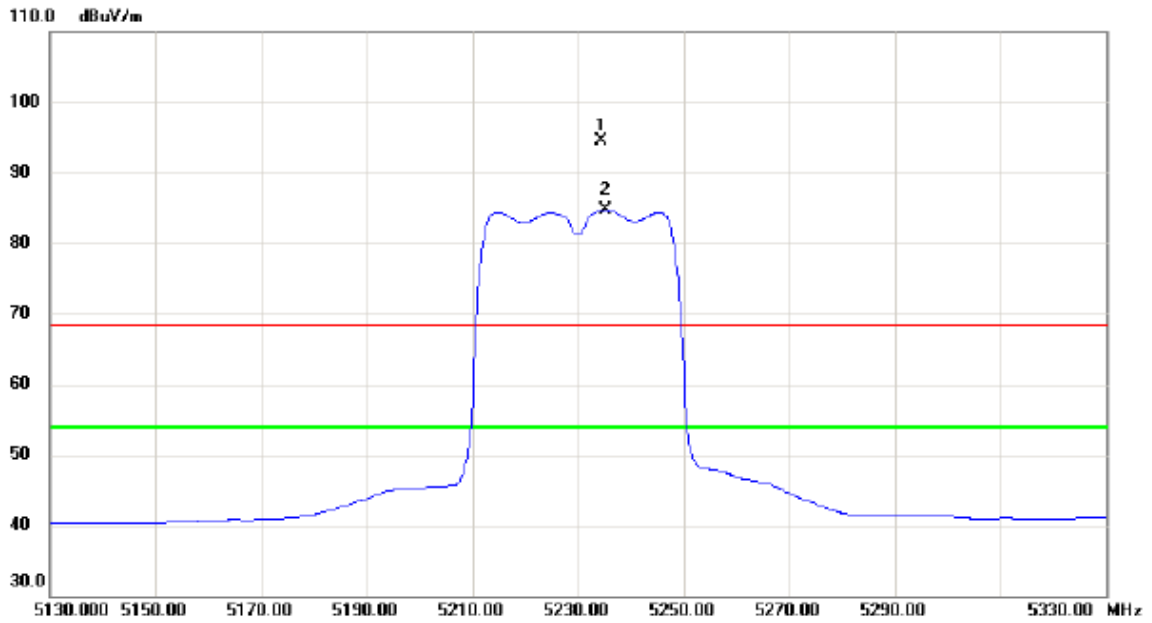

No.	Mk.	Freq.	Reading Level	Correct Factor	Measurement	Limit	Margin		
		MHz	dBuV	dB	dBuV/m	dBuV/m	dB	Detector	Comment
1	X	5234.400	53.67	40.90	94.57	68.30	26.27	peak	No Limit
2	*	5235.200	43.72	40.90	84.62	54.00	30.62	AVG	No Limit

Orthogonal Axis:	X
Test Mode:	UNII-1/ TX AC(VHT40) Mode 5230MHz

Horizontal

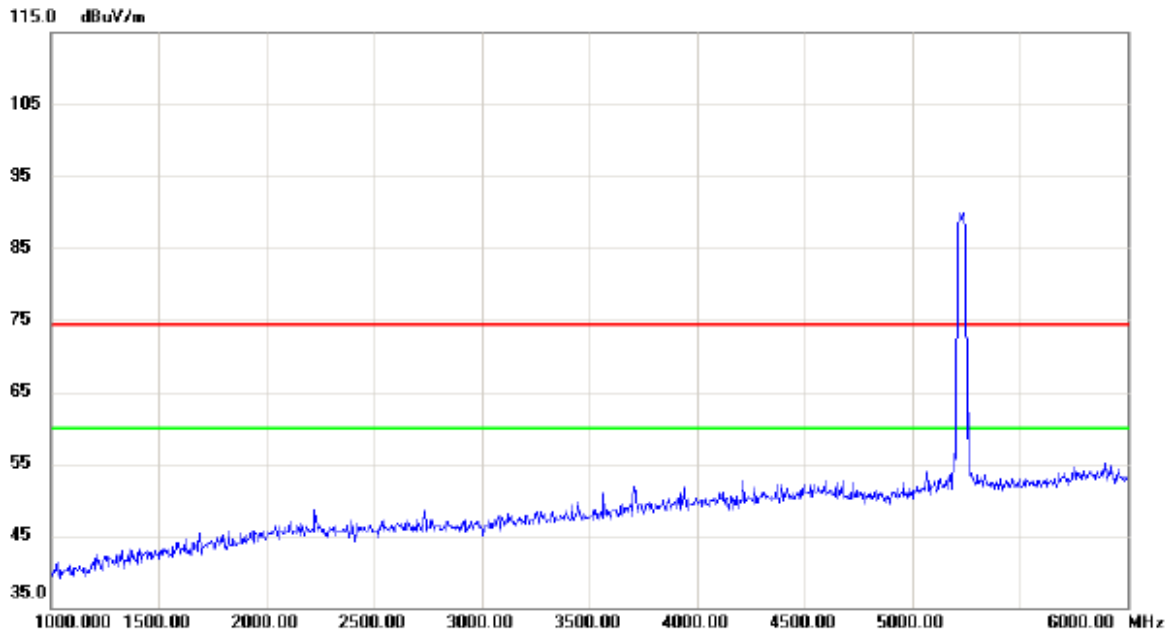

No.	Mk.	Freq.	Reading Level	Correct Factor	Measurement	Limit	Margin	Detector	Comment
		MHz	dBuV	dB	dBuV/m	dBuV/m	dB		

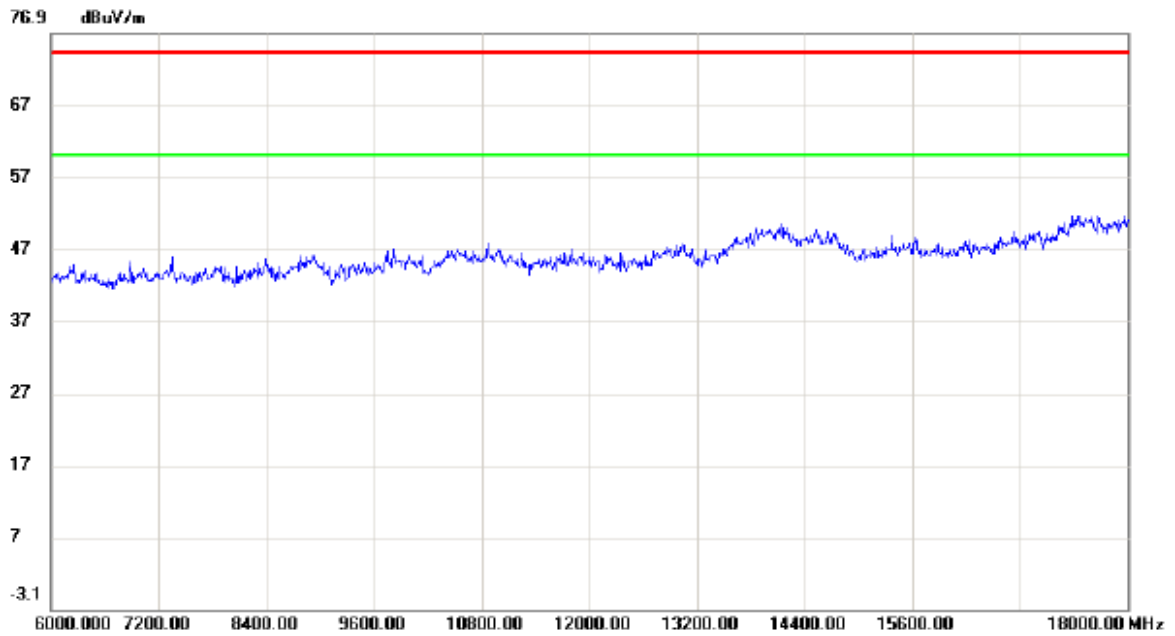

No.	Mk.	Freq.	Reading Level	Correct Factor	Measurement	Limit	Margin	Detector	Comment
		MHz	dBuV	dB	dBuV/m	dBuV/m	dB		

Orthogonal Axis:	X
Test Mode:	UNII-1/ TX AC(VHT40) Mode 5230MHz

Horizontal

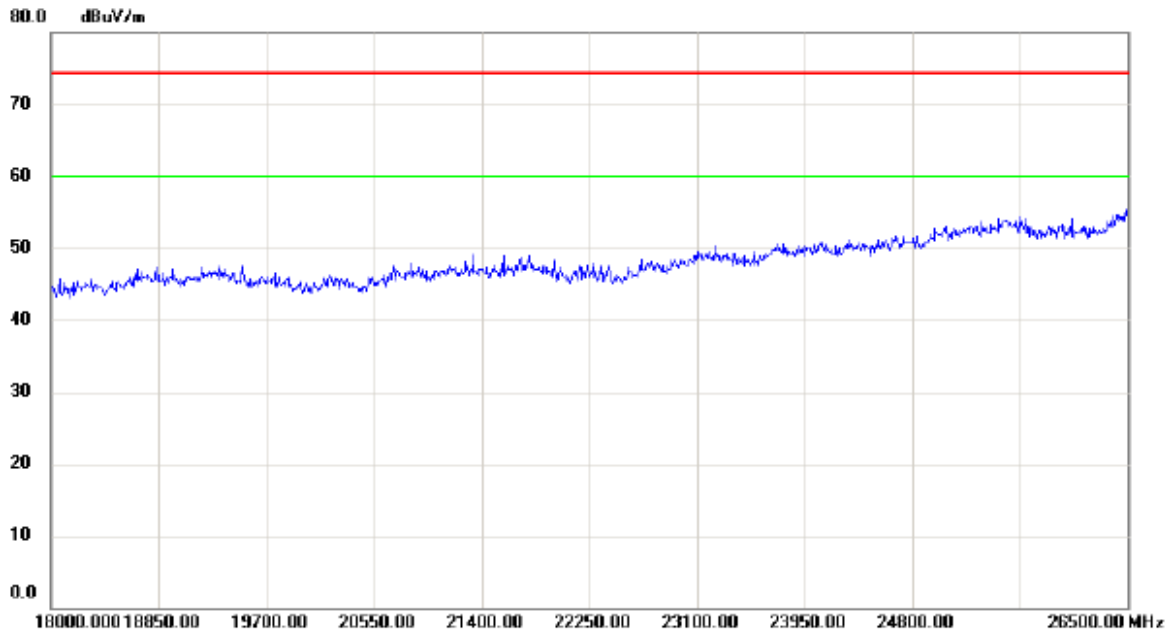

No.	Mk.	Freq.	Reading Level	Correct Factor	Measurement	Limit	Margin	Detector	Comment
		MHz	dBuV	dB	dBuV/m	dBuV/m	dB		

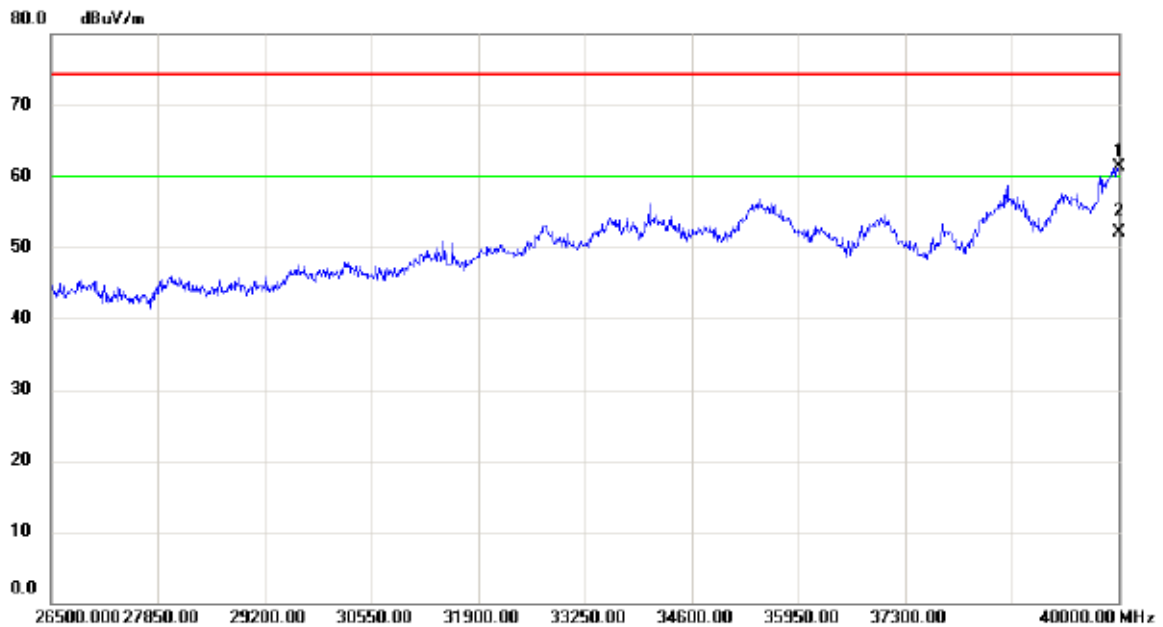

No.	Mk.	Freq.	Reading Level	Correct Factor	Measurement	Limit	Margin	Detector	Comment
		MHz	dBuV	dB	dBuV/m	dBuV/m	dB		
1		40000.00	45.41	15.89	61.30	74.30	-13.00	peak	
2	*	40000.00	36.28	15.89	52.17	60.00	-7.83	AVG	

Orthogonal Axis:	X
Test Mode:	UNII-1/ TX AC(VHT80) Mode 5210MHz

Vertical

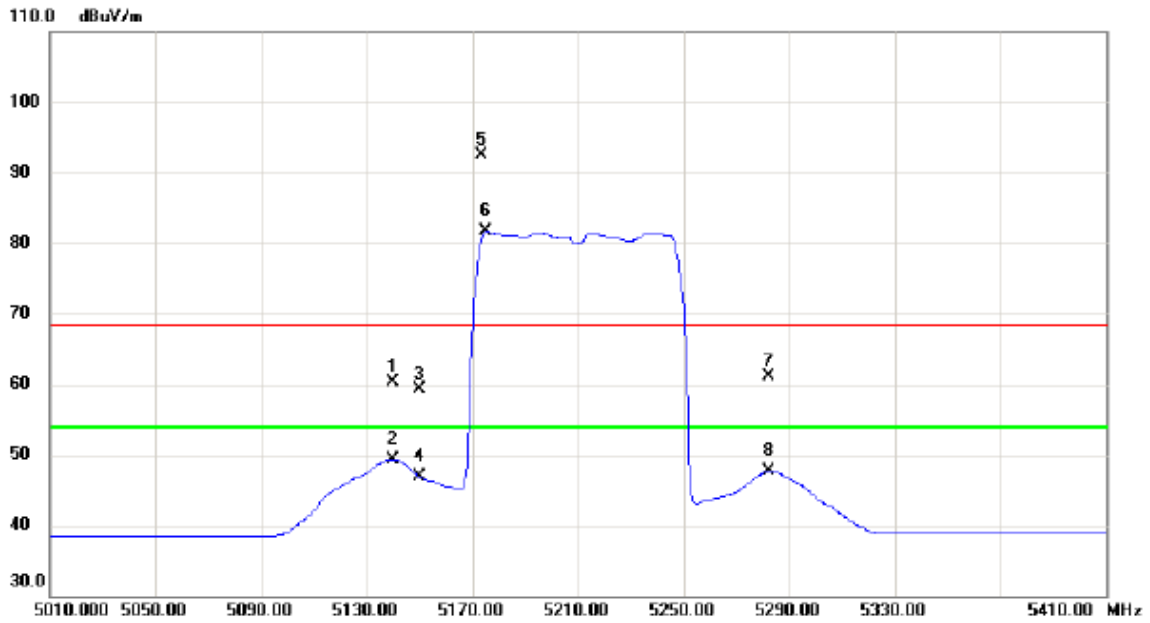

No.	Mk.	Freq. MHz	Reading Level dBuV	Correct Factor dB	Measure- ment dBuV/m	Limit dBuV/m	Margin dB	Detector	Comment
1		5139.600	19.67	40.60	60.27	68.30	-8.03	peak	
2		5139.600	8.77	40.60	49.37	54.00	-4.63	AVG	
3		5150.000	18.63	40.63	59.26	68.30	-9.04	peak	
4		5150.000	6.22	40.63	46.85	54.00	-7.15	AVG	
5	X	5173.600	51.87	40.71	92.58	68.30	24.28	peak	No Limit
6	*	5175.200	40.98	40.71	81.69	54.00	27.69	AVG	No Limit
7		5282.400	20.13	41.06	61.19	68.30	-7.11	peak	
8		5282.400	6.60	41.06	47.66	54.00	-6.34	AVG	

Orthogonal Axis:	X
Test Mode:	UNII-1/ TX AC(VHT80) Mode 5210MHz

Vertical

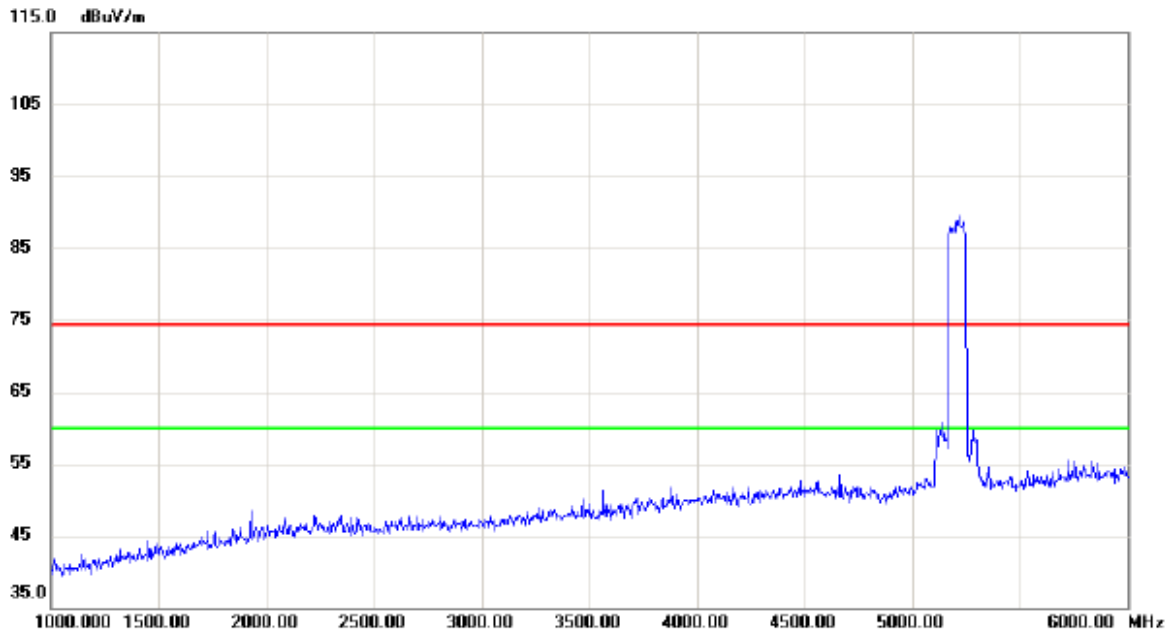

No.	Mk.	Freq.	Reading Level	Correct Factor	Measurement	Limit	Margin	Detector	Comment
		MHz	dBuV	dB	dBuV/m	dBuV/m	dB		

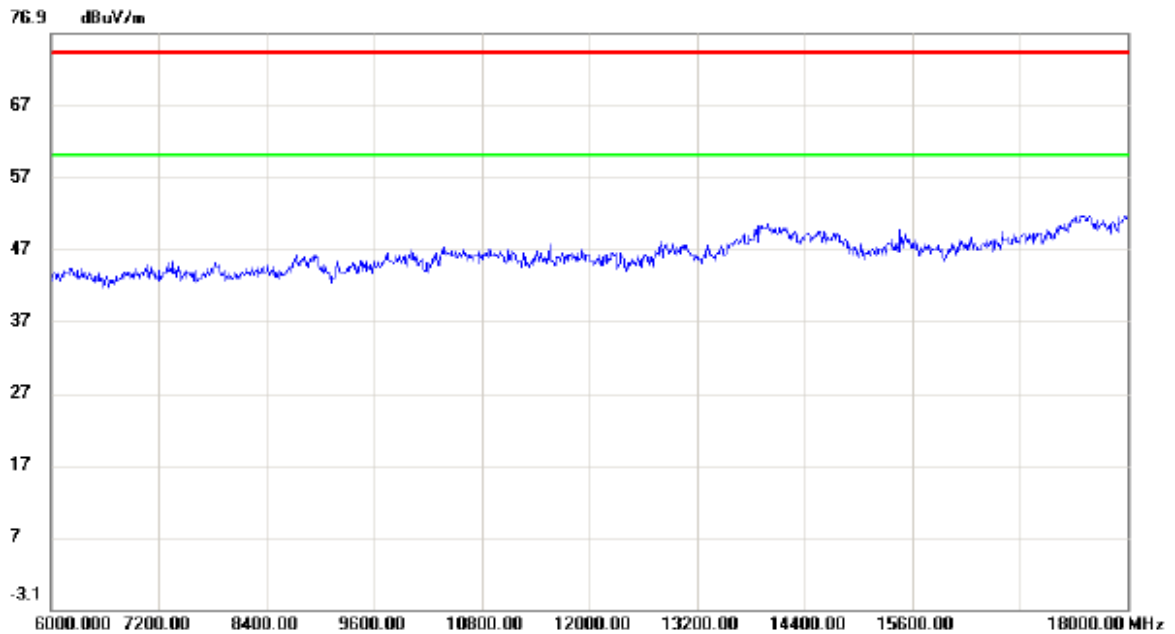

No.	Mk.	Freq.	Reading Level	Correct Factor	Measurement	Limit	Margin	Detector	Comment
		MHz	dBuV	dB	dBuV/m	dBuV/m	dB		

Orthogonal Axis:	X
Test Mode:	UNII-1/ TX AC(VHT80) Mode 5210MHz

Vertical

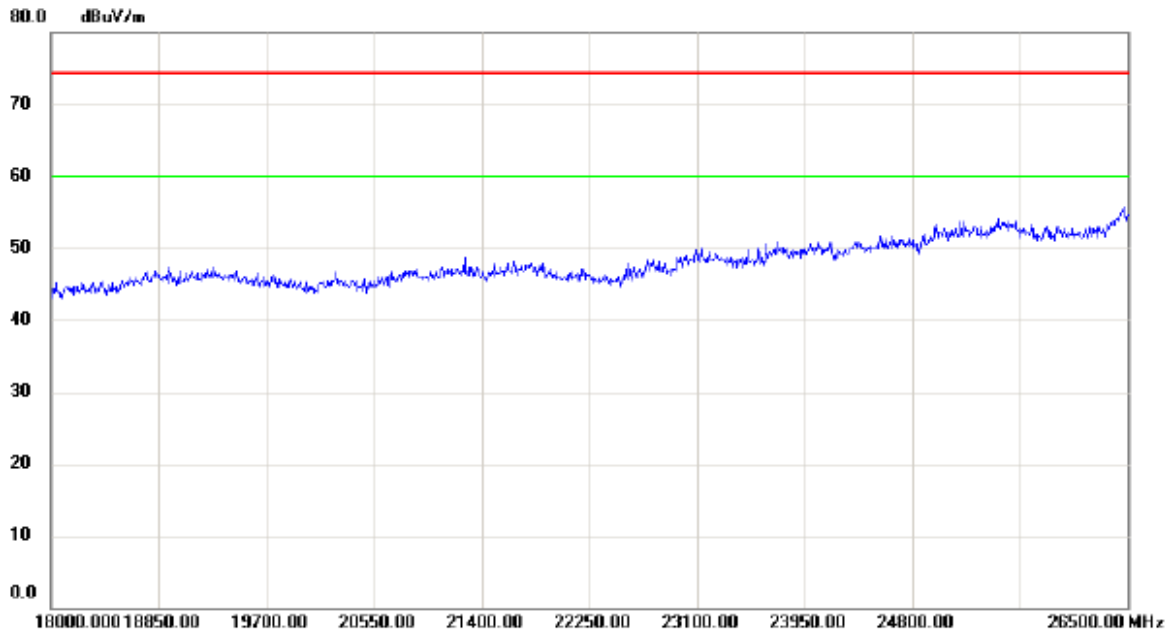

No.	Mk.	Freq.	Reading Level	Correct Factor	Measurement	Limit	Margin	Detector	Comment
		MHz	dBuV	dB	dBuV/m	dBuV/m	dB		

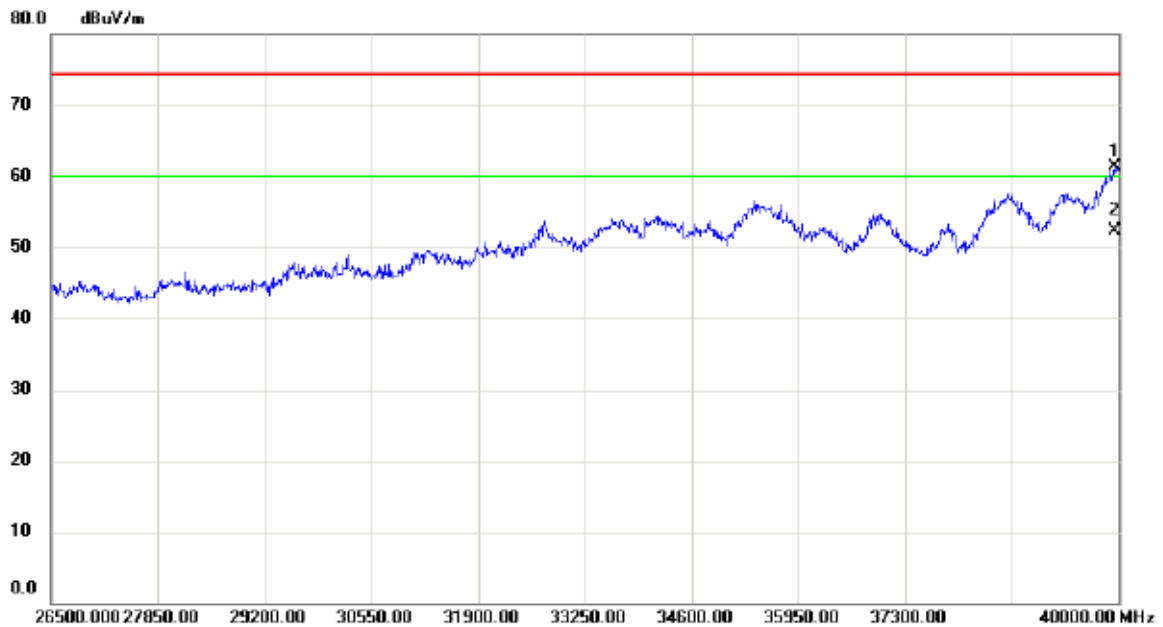

No.	Mk.	Freq.	Reading Level	Correct Factor	Measurement	Limit	Margin	Detector	Comment
		MHz	dBuV	dB	dBuV/m	dBuV/m	dB		
1		39946.00	45.42	15.81	61.23	74.30	-13.07	peak	
2	*	39946.18	36.48	15.81	52.29	60.00	-7.71	AVG	

Orthogonal Axis:	X
Test Mode:	UNII-1/ TX AC(VHT80) Mode 5210MHz

Horizontal

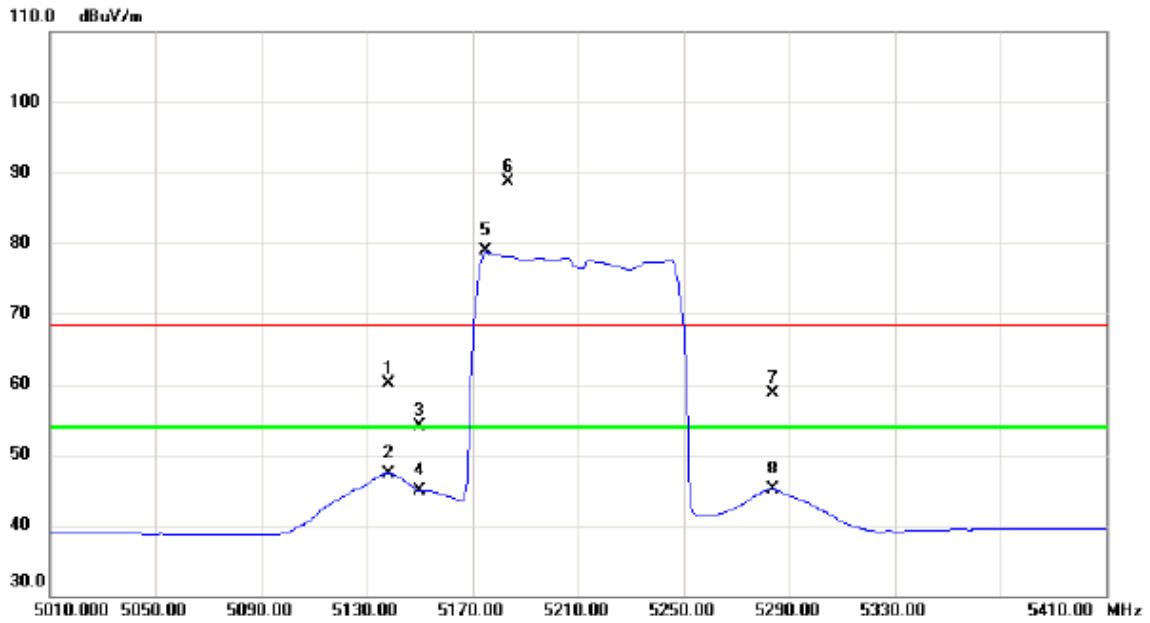

No.	Mk.	Freq. MHz	Reading Level dBuV	Correct Factor dB	Measure- ment dBuV/m	Limit dBuV/m	Margin dB	Detector	Comment
1		5138.400	19.55	40.58	60.13	68.30	-8.17	peak	
2		5138.400	6.68	40.58	47.26	54.00	-6.74	AVG	
3		5150.000	13.56	40.63	54.19	68.30	-14.11	peak	
4		5150.000	4.32	40.63	44.95	54.00	-9.05	AVG	
5	*	5175.200	38.11	40.71	78.82	54.00	24.82	AVG	No Limit
6	X	5183.600	47.88	40.74	88.62	68.30	20.32	peak	No Limit
7		5283.600	17.60	41.07	58.67	68.30	-9.63	peak	
8		5283.600	4.00	41.07	45.07	54.00	-8.93	AVG	

Orthogonal Axis:	X
Test Mode:	UNII-1/ TX AC(VHT80) Mode 5210MHz

Horizontal

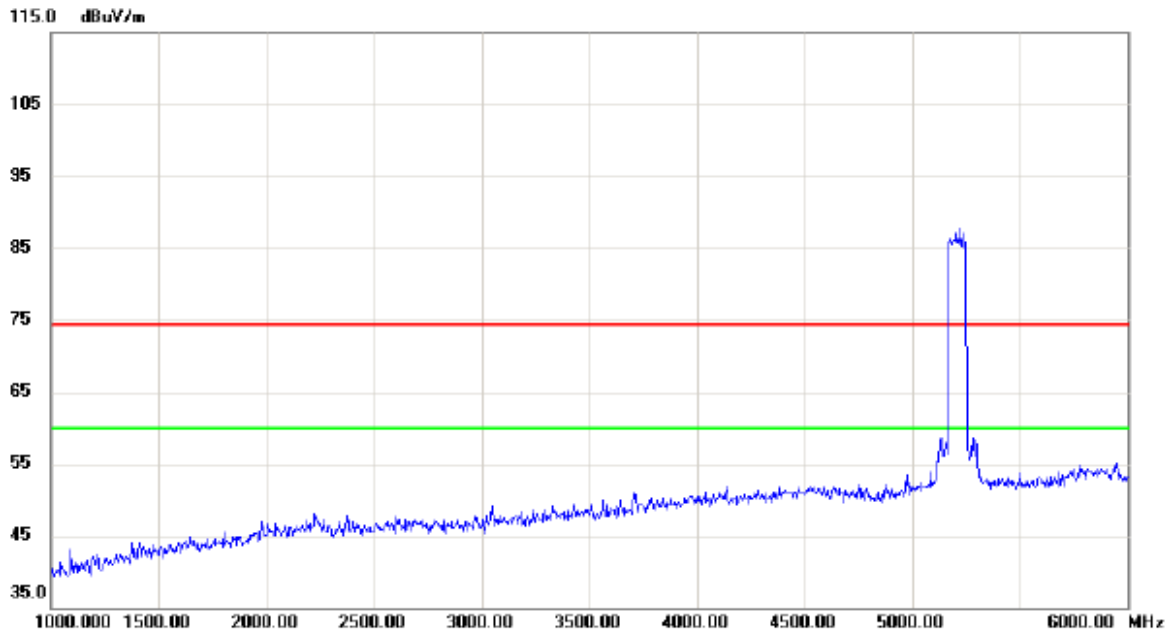

No.	Mk.	Freq.	Reading Level	Correct Factor	Measurement	Limit	Margin	Detector	Comment
		MHz	dBuV	dB	dBuV/m	dBuV/m	dB		

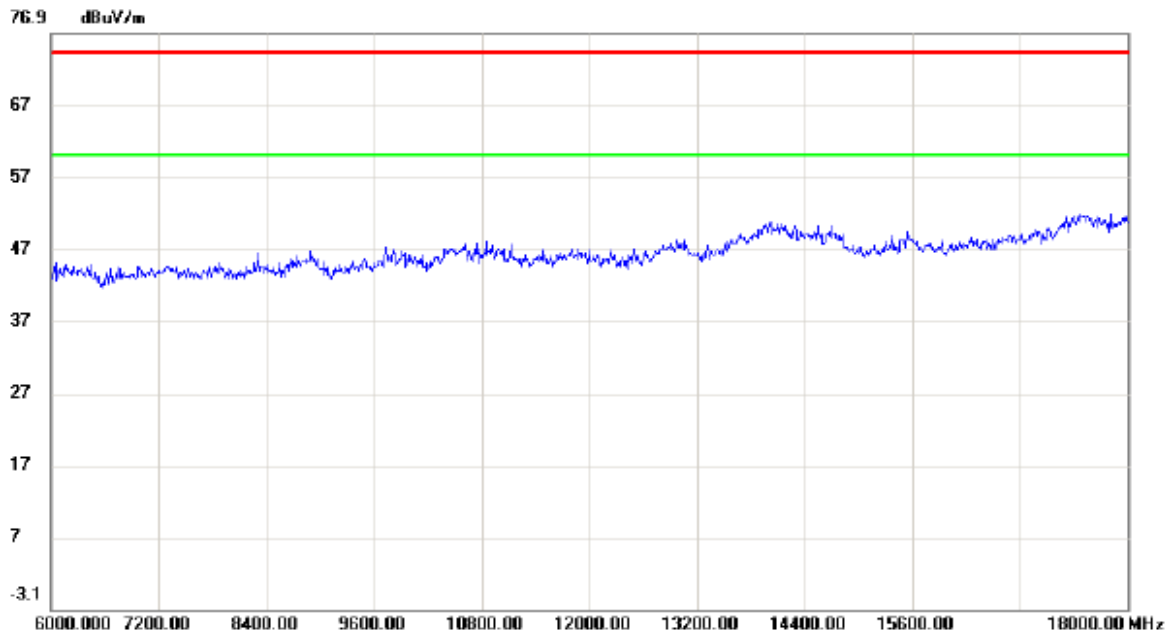

No.	Mk.	Freq.	Reading Level	Correct Factor	Measurement	Limit	Margin	Detector	Comment
		MHz	dBuV	dB	dBuV/m	dBuV/m	dB		

Orthogonal Axis:	X
Test Mode:	UNII-1/ TX AC(VHT80) Mode 5210MHz

Horizontal

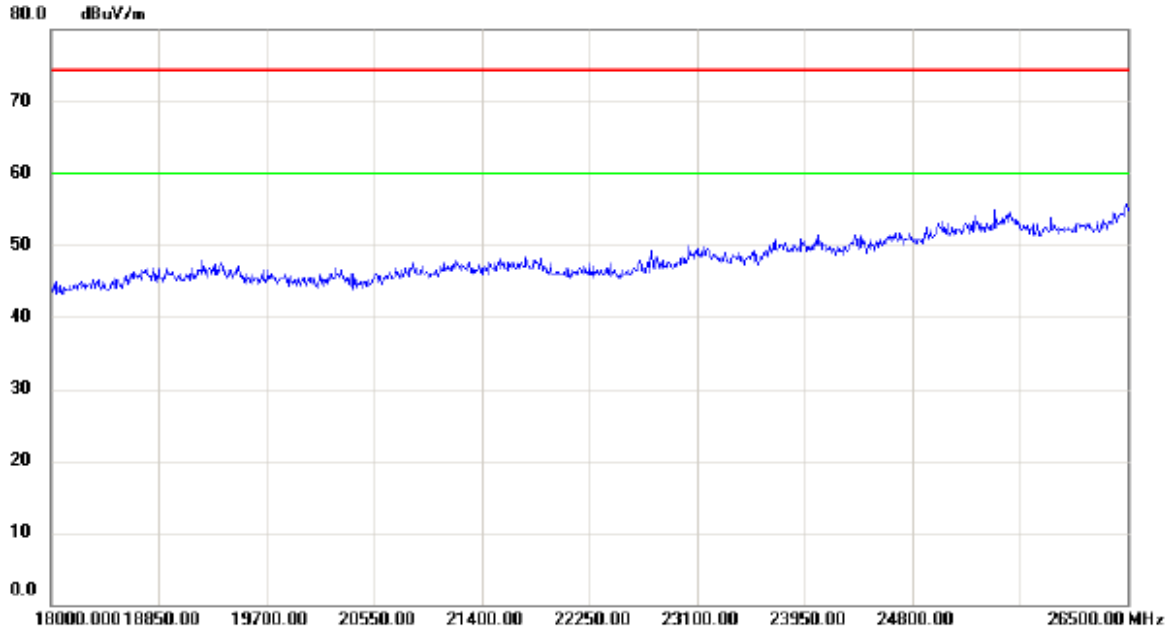

No.	Mk.	Freq.	Reading Level	Correct Factor	Measurement	Limit	Margin	Detector	Comment
		MHz	dBuV	dB	dBuV/m	dBuV/m	dB		

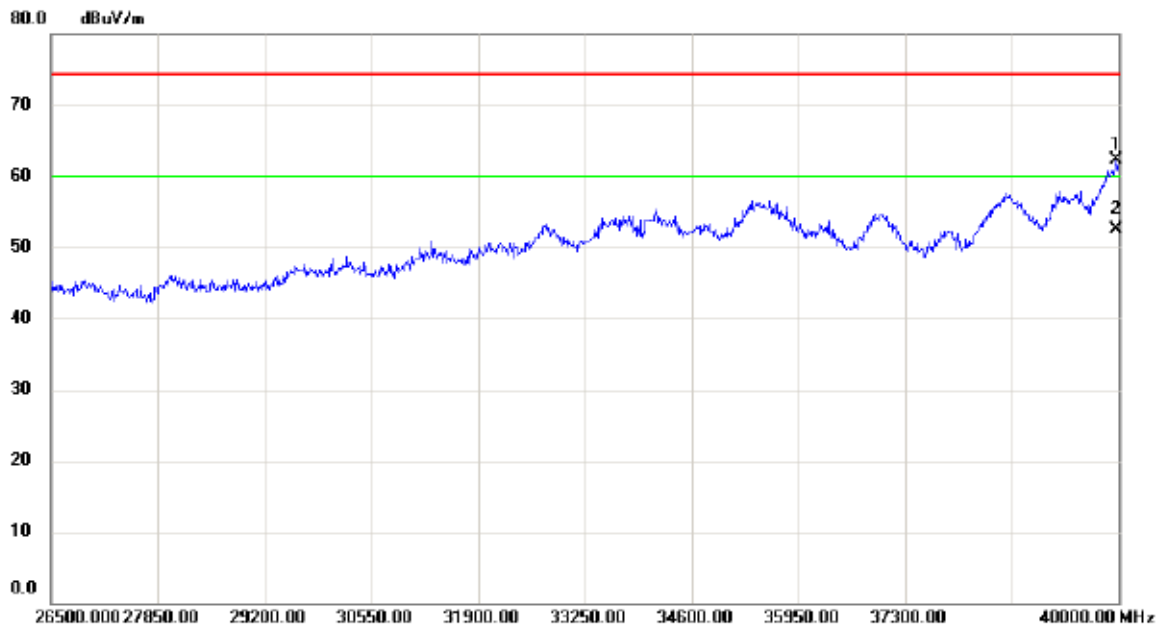

No.	Mk.	Freq.	Reading Level	Correct Factor	Measurement	Limit	Margin	Detector	Comment
		MHz	dBuV	dB	dBuV/m	dBuV/m	dB		
1		39973.00	46.39	15.84	62.23	74.30	-12.07	peak	
2	*	39973.00	36.69	15.84	52.53	60.00	-7.47	AVG	

Orthogonal Axis:	X
Test Mode:	UNII-3/TX A Mode 5745MHz

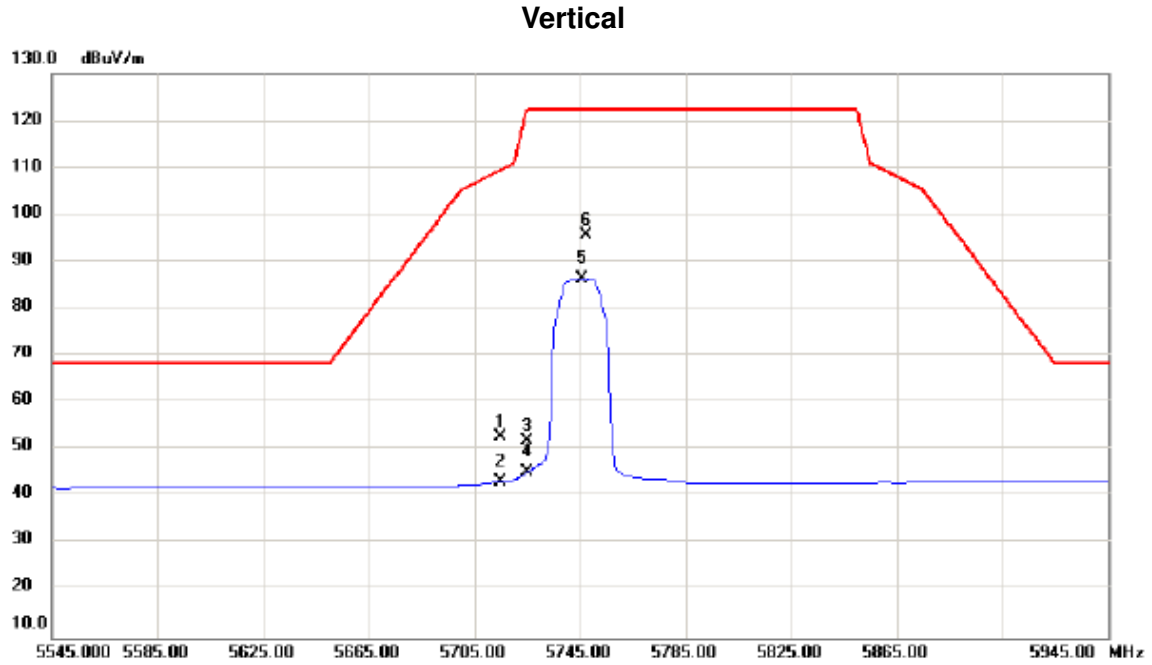

No.	Mk.	Freq.	Reading Level	Correct Factor	Measurement	Limit	Margin	Detector	Comment
		MHz	dBuV	dB	dBuV/m	dBuV/m	dB		
1		5715.000	10.07	42.55	52.62	109.50	-56.88	peak	
2		5715.000	0.62	42.55	43.17	109.50	-66.33	AVG	
3		5725.000	9.22	42.58	51.80	122.30	-70.50	peak	
4		5725.000	2.52	42.58	45.10	122.30	-77.20	AVG	
5		5745.800	43.59	42.66	86.25	122.30	-36.05	AVG	
6	*	5747.400	53.12	42.66	95.78	122.30	-26.52	peak	

Orthogonal Axis:	X
Test Mode:	UNII-3/TX A Mode 5745MHz

Vertical

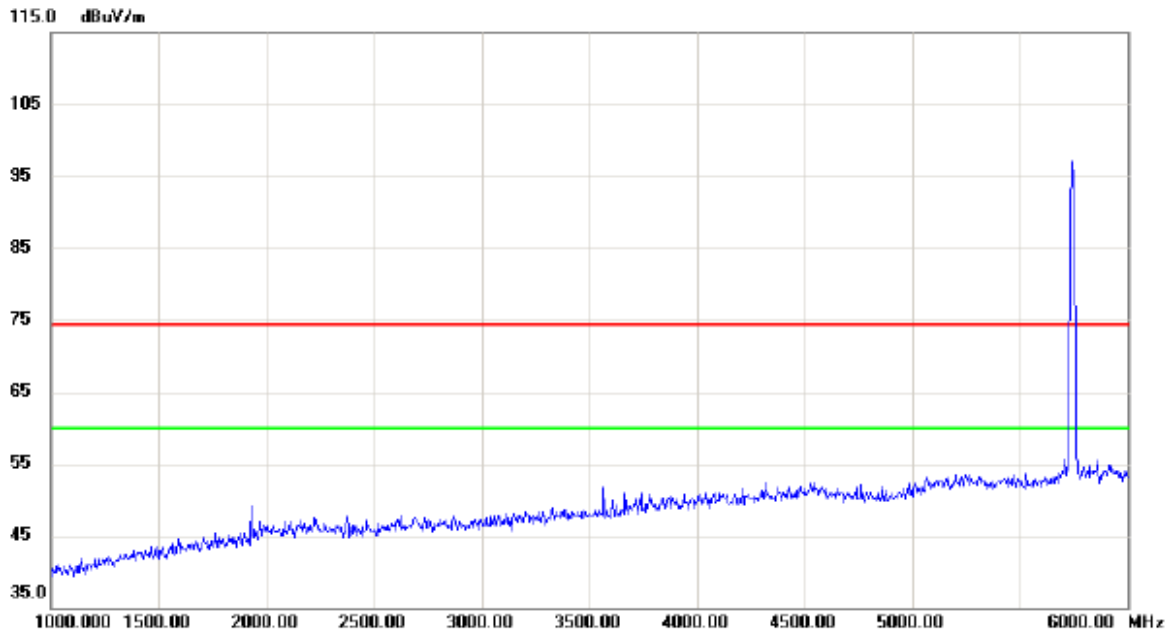

No.	Mk.	Freq.	Reading Level	Correct Factor	Measurement	Limit	Margin	Detector	Comment
		MHz	dBuV	dB	dBuV/m	dBuV/m	dB		

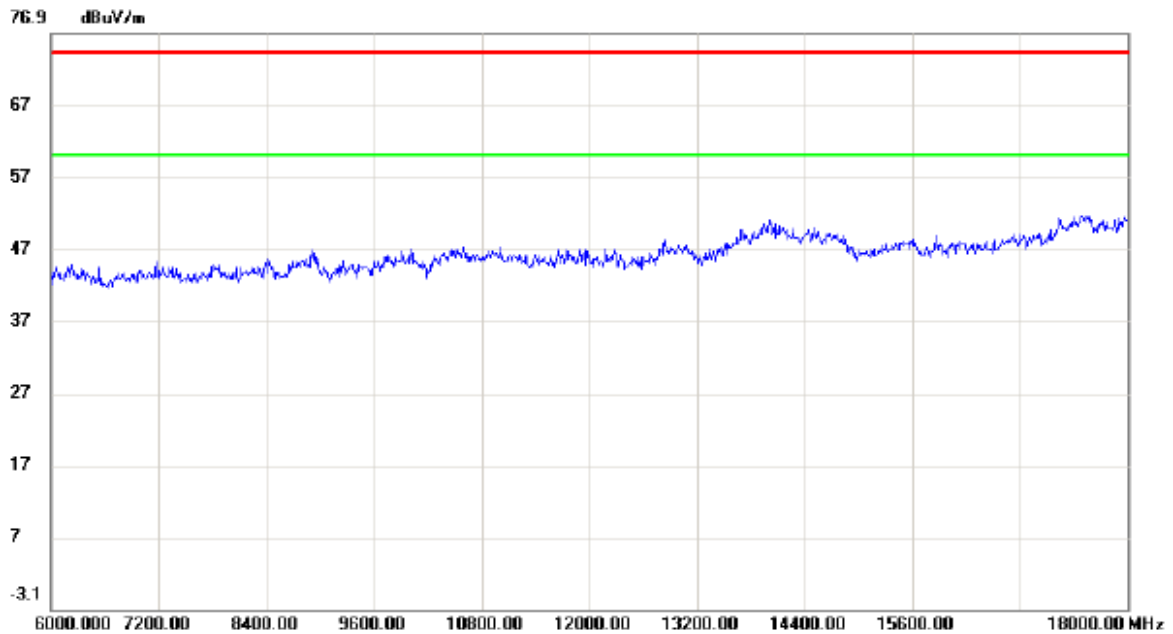

No.	Mk.	Freq.	Reading Level	Correct Factor	Measurement	Limit	Margin	Detector	Comment
		MHz	dBuV	dB	dBuV/m	dBuV/m	dB		

Orthogonal Axis:	X
Test Mode:	UNII-3/TX A Mode 5745MHz

Vertical

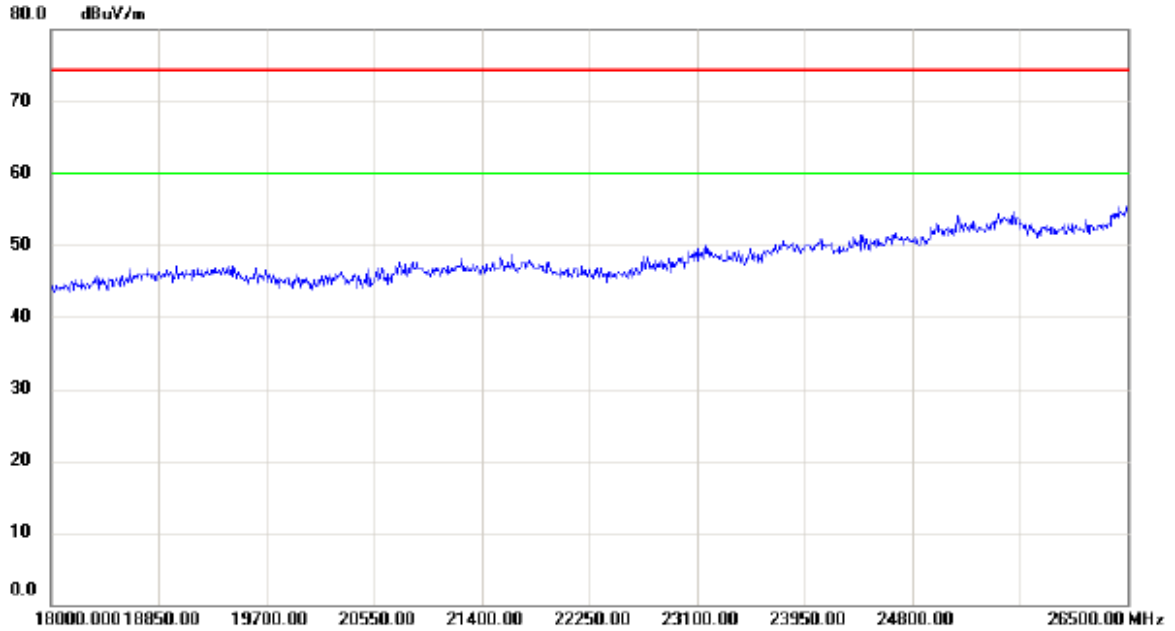

No.	Mk.	Freq.	Reading Level	Correct Factor	Measurement	Limit	Margin	Detector	Comment
		MHz	dBuV	dB	dBuV/m	dBuV/m	dB		

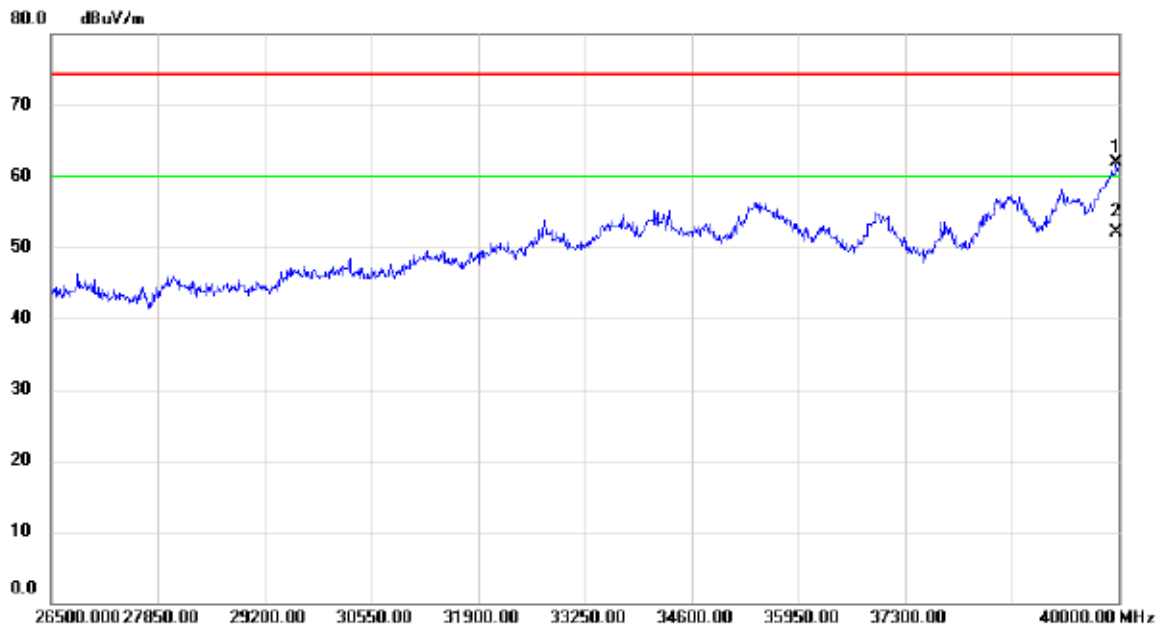

No.	Mk.	Freq.	Reading Level	Correct Factor	Measurement	Limit	Margin	Detector	Comment
		MHz	dBuV	dB	dBuV/m	dBuV/m	dB		
1		39973.00	46.15	15.84	61.99	74.30	-12.31	peak	
2	*	39973.33	36.24	15.84	52.08	60.00	-7.92	AVG	

Orthogonal Axis:	X
Test Mode:	UNII-3/TX A Mode 5745MHz

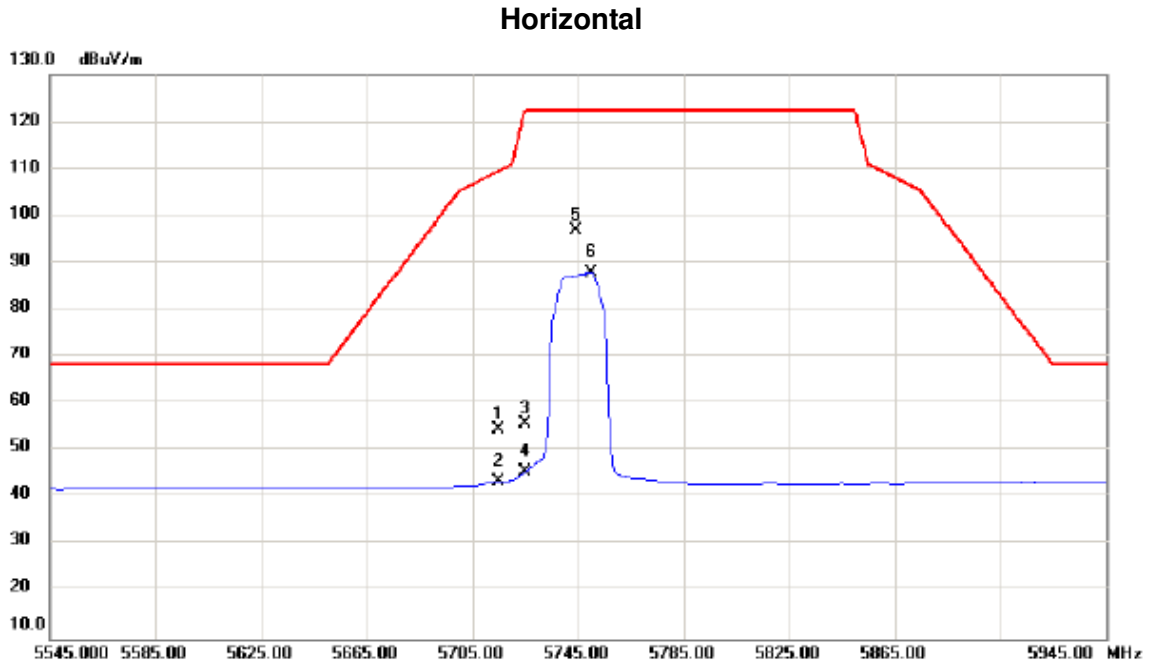

No.	Mk.	Freq.	Reading Level	Correct Factor	Measurement	Limit	Margin	Detector	Comment
		MHz	dBuV	dB	dBuV/m	dBuV/m	dB		
1		5715.000	11.88	42.55	54.43	109.50	-55.07	peak	
2		5715.000	0.81	42.55	43.36	109.50	-66.14	AVG	
3		5725.000	13.12	42.58	55.70	122.30	-66.60	peak	
4		5725.000	2.94	42.58	45.52	122.30	-76.78	AVG	
5	*	5744.200	54.14	42.65	96.79	122.30	-25.51	peak	
6		5750.200	45.23	42.67	87.90	122.30	-34.40	AVG	

Orthogonal Axis:	X
Test Mode:	UNII-3/TX A Mode 5745MHz

Horizontal

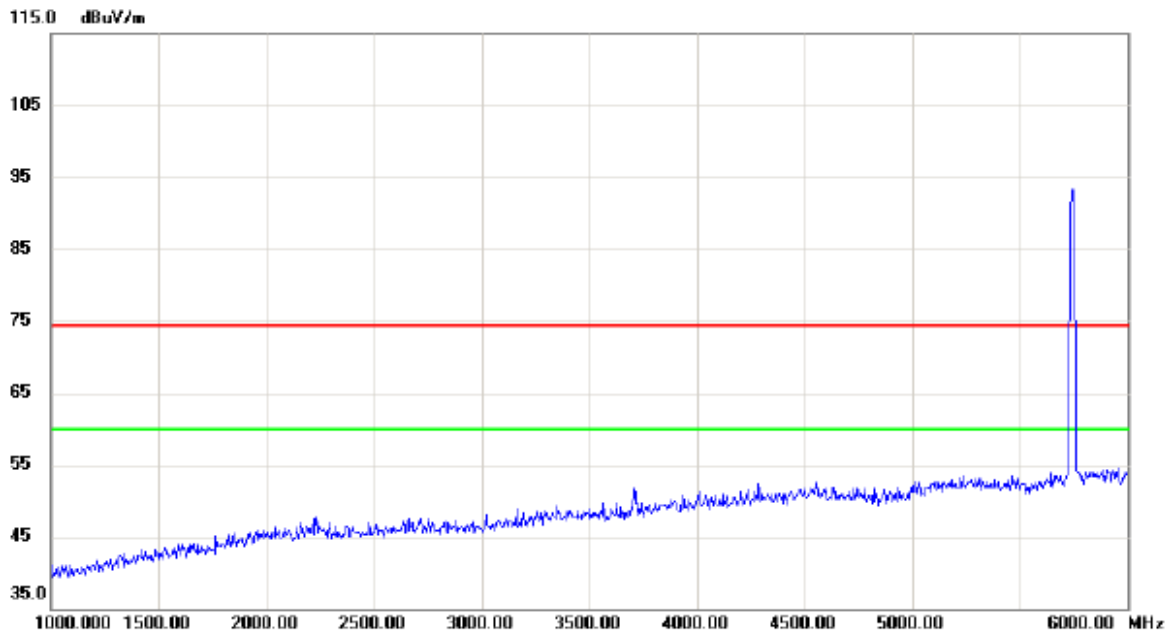

No.	Mk.	Freq.	Reading Level	Correct Factor	Measurement	Limit	Margin	Detector	Comment
		MHz	dBuV	dB	dBuV/m	dBuV/m	dB		

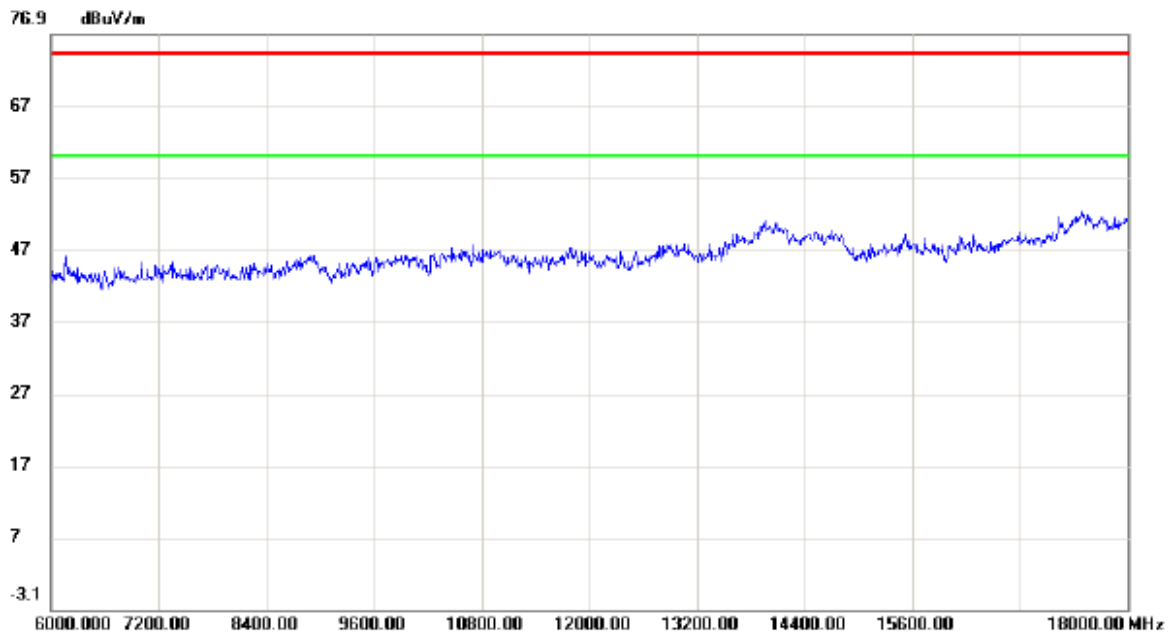

No.	Mk.	Freq.	Reading Level	Correct Factor	Measurement	Limit	Margin	Detector	Comment
		MHz	dBuV	dB	dBuV/m	dBuV/m	dB		

Orthogonal Axis:	X
Test Mode:	UNII-3/TX A Mode 5745MHz

Horizontal

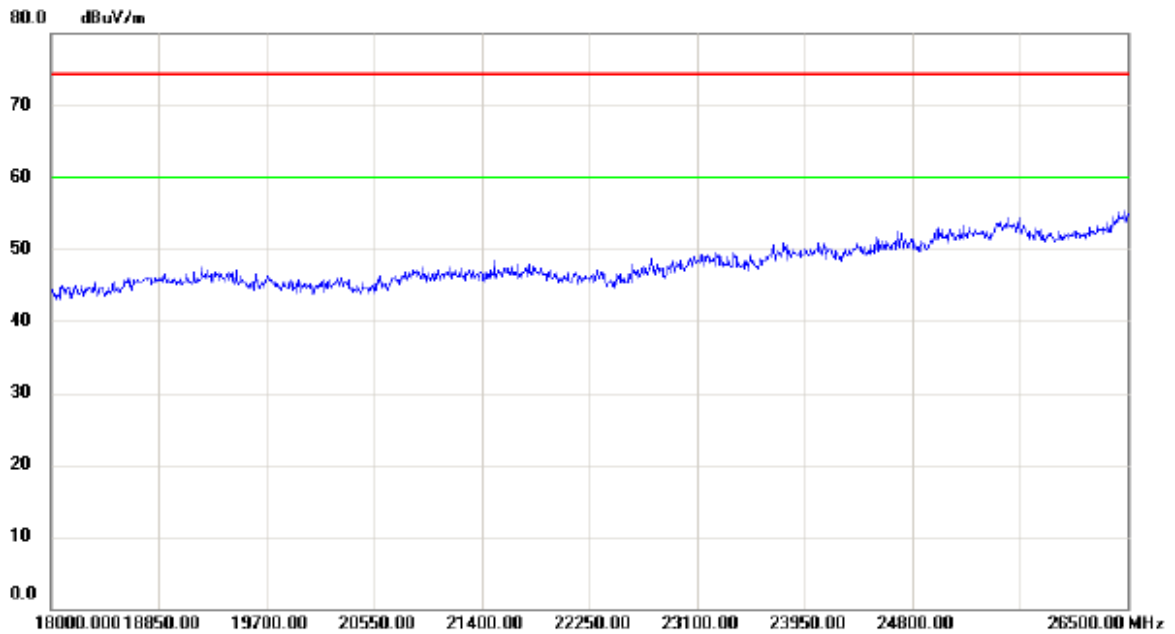

No.	Mk.	Freq.	Reading Level	Correct Factor	Measurement	Limit	Margin	Detector	Comment
		MHz	dBuV	dB	dBuV/m	dBuV/m	dB		

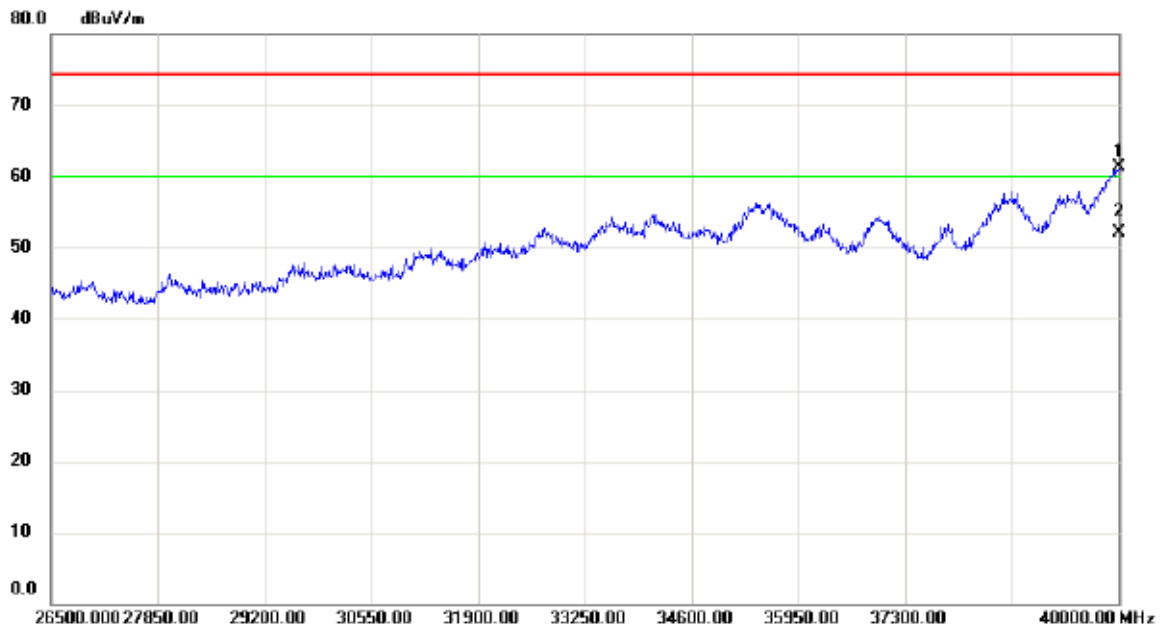

No.	Mk.	Freq.	Reading Level	Correct Factor	Measurement	Limit	Margin	Detector	Comment
		MHz	dBuV	dB	dBuV/m	dBuV/m	dB		
1		40000.00	45.37	15.89	61.26	74.30	-13.04	peak	
2	*	40000.00	36.13	15.89	52.02	60.00	-7.98	AVG	

Orthogonal Axis:	X
Test Mode:	UNII-3/TX A Mode 5825MHz

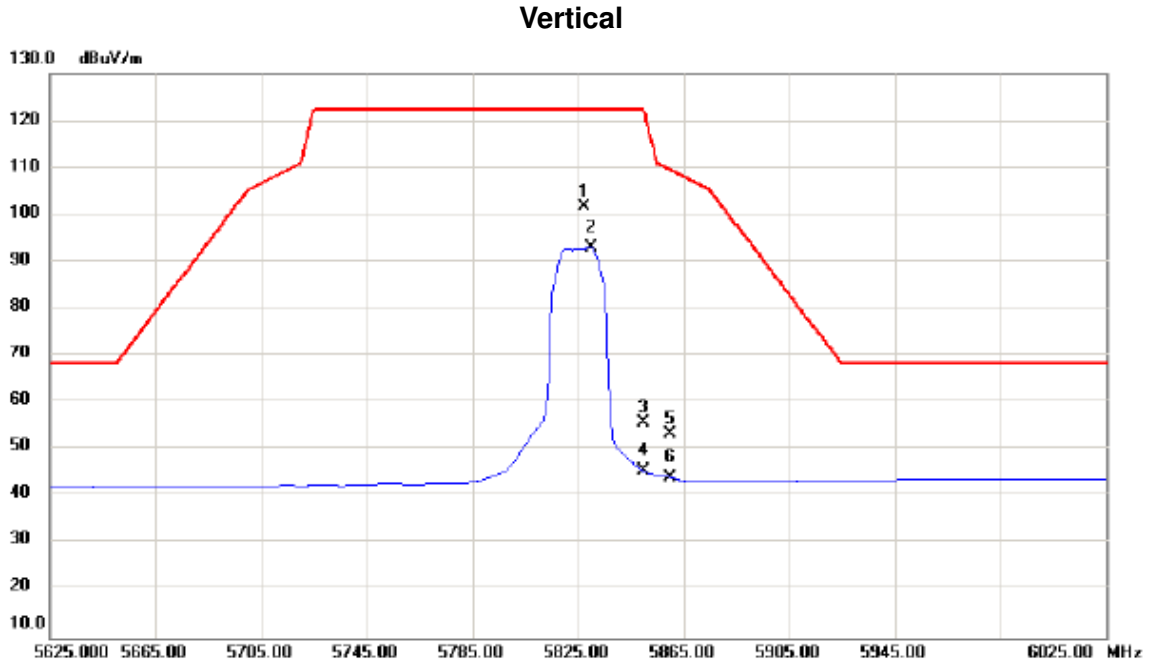

No.	Mk.	Freq.	Reading Level	Correct Factor	Measurement	Limit	Margin	Detector	Comment
		MHz	dBuV	dB	dBuV/m	dBuV/m	dB		
1	*	5827.400	58.59	42.95	101.54	122.30	-20.76	peak	
2		5830.200	50.07	42.95	93.02	122.30	-29.28	AVG	
3		5850.000	12.87	43.03	55.90	122.30	-66.40	peak	
4		5850.000	2.39	43.03	45.42	122.30	-76.88	AVG	
5		5860.000	10.33	43.06	53.39	109.50	-56.11	peak	
6		5860.000	1.03	43.06	44.09	109.50	-65.41	AVG	

Orthogonal Axis:	X
Test Mode:	UNII-3/TX A Mode 5825MHz

Vertical

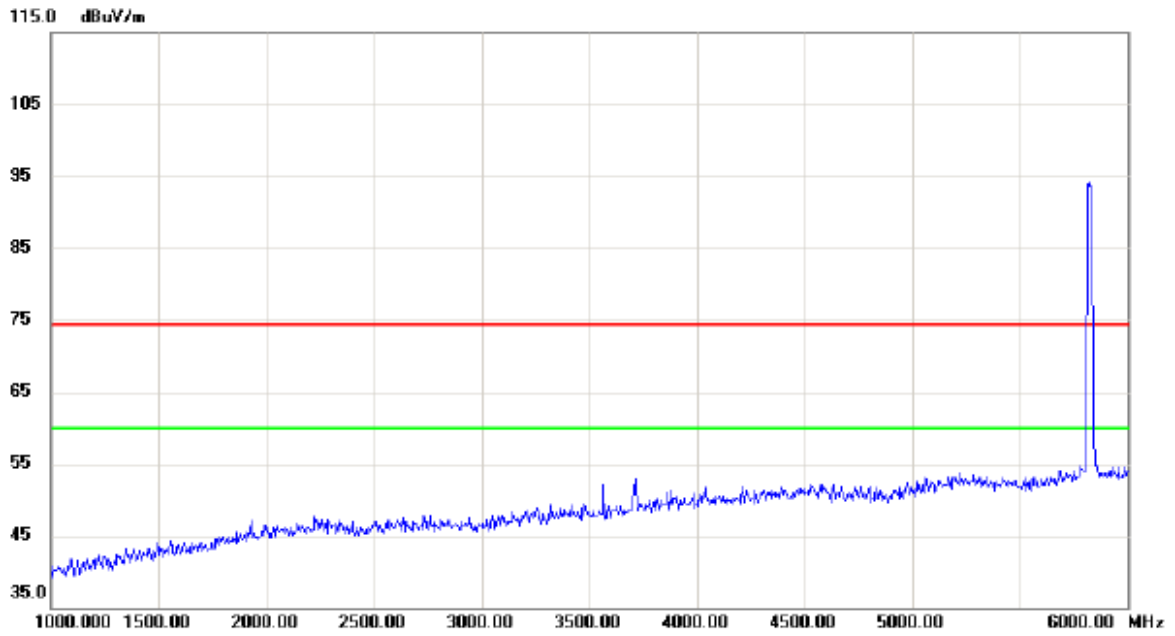

No.	Mk.	Freq.	Reading Level	Correct Factor	Measurement	Limit	Margin	Detector	Comment
		MHz	dBuV	dB	dBuV/m	dBuV/m	dB		

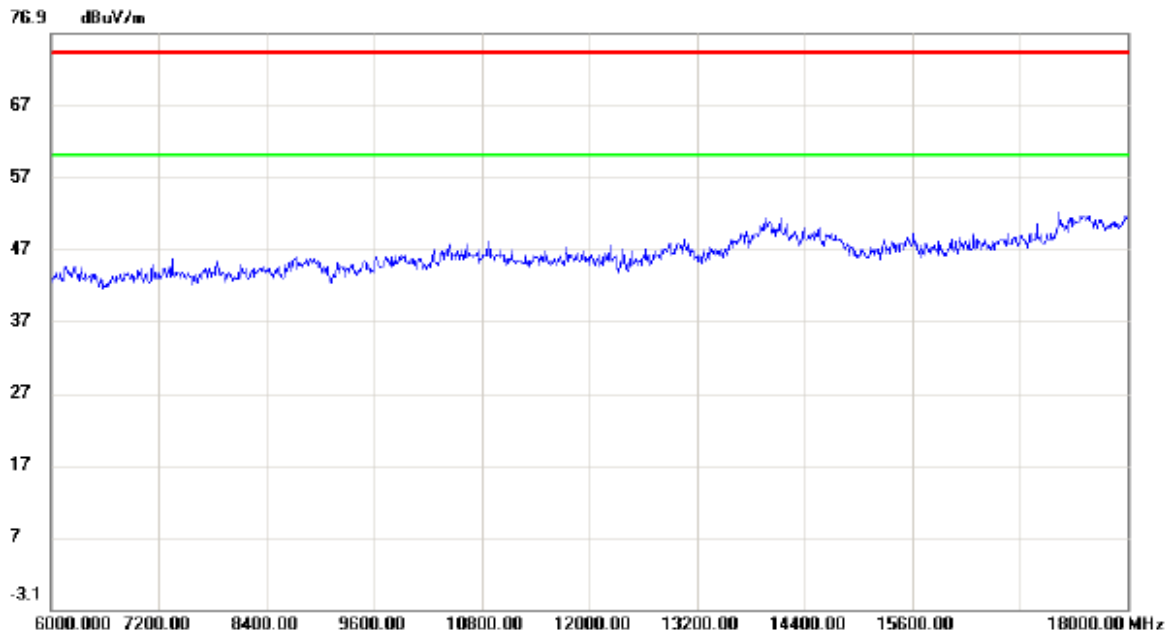

No.	Mk.	Freq.	Reading Level	Correct Factor	Measurement	Limit	Margin	Detector	Comment
		MHz	dBuV	dB	dBuV/m	dBuV/m	dB		

Orthogonal Axis:	X
Test Mode:	UNII-3/TX A Mode 5825MHz

Vertical

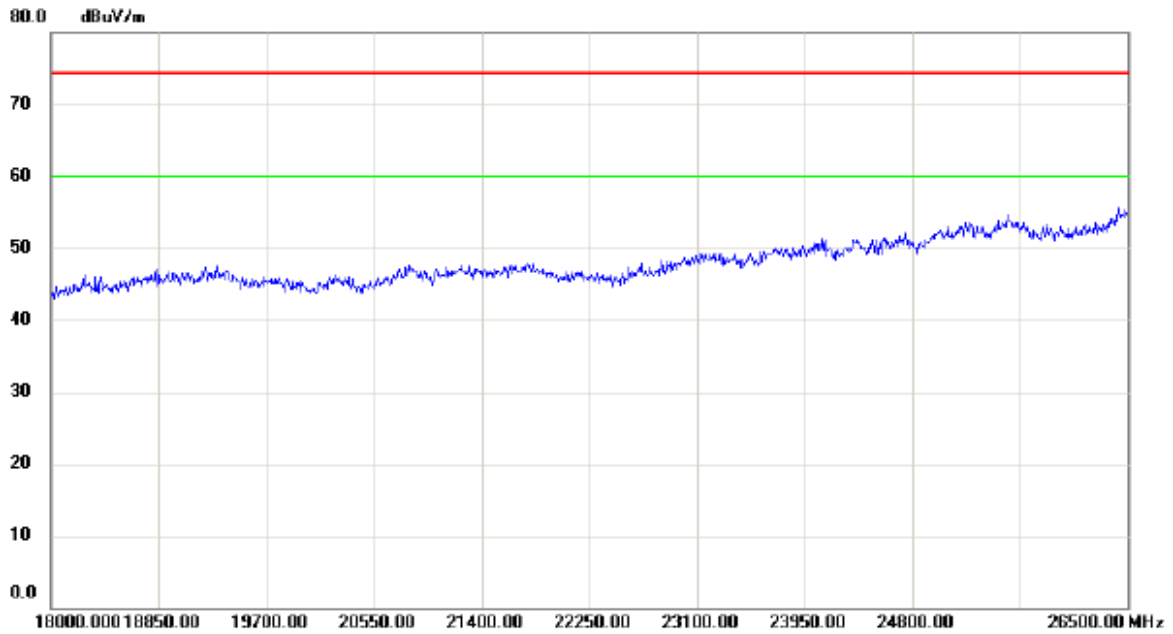

No.	Mk.	Freq.	Reading Level	Correct Factor	Measurement	Limit	Margin	Detector	Comment
		MHz	dBuV	dB	dBuV/m	dBuV/m	dB		

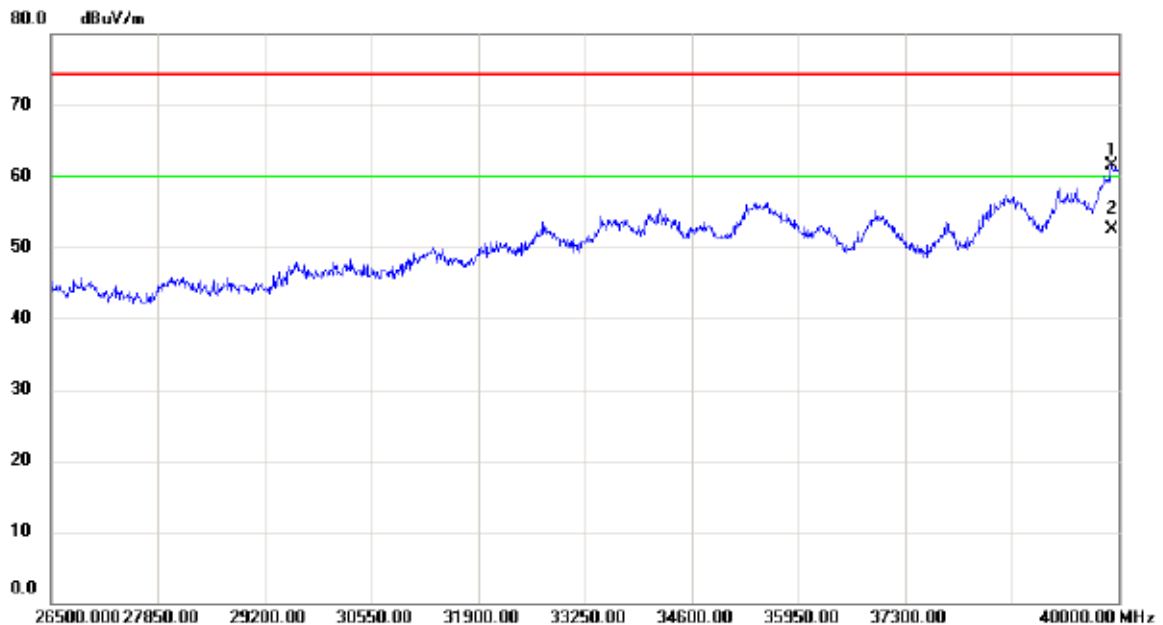

No.	Mk.	Freq.	Reading Level	Correct Factor	Measurement	Limit	Margin	Detector	Comment
		MHz	dBuV	dB	dBuV/m	dBuV/m	dB		
1		39919.00	45.67	15.76	61.43	74.30	-12.87	peak	
2	*	39919.33	36.66	15.76	52.42	60.00	-7.58	AVG	

Orthogonal Axis:	X
Test Mode:	UNII-3/TX A Mode 5825MHz

Horizontal

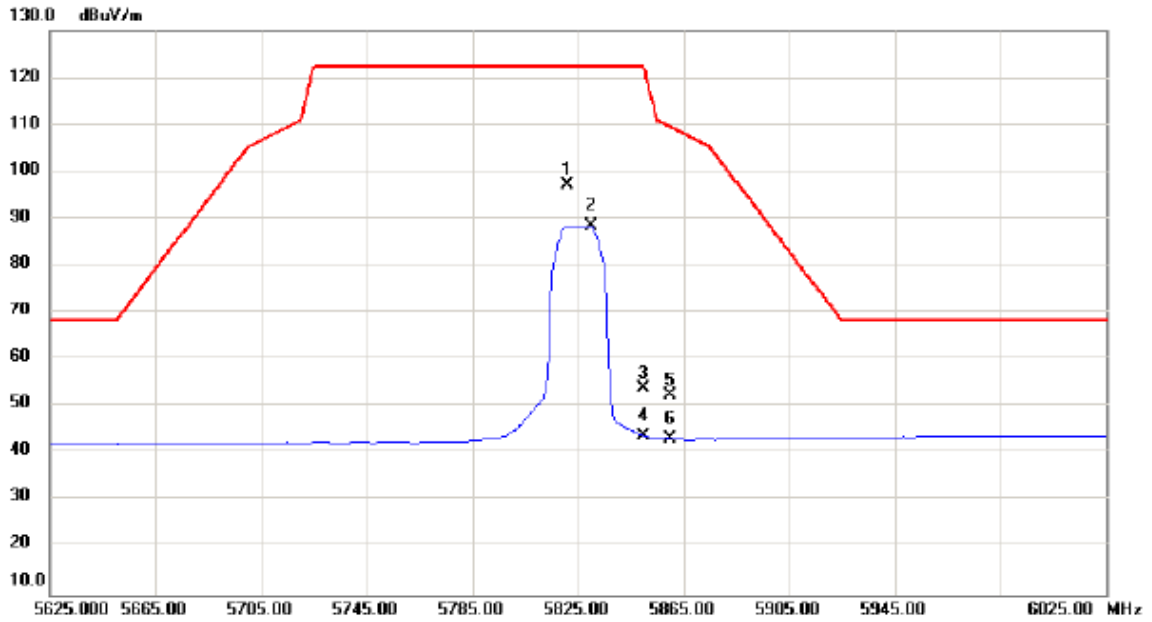

No.	Mk.	Freq.	Reading Level	Correct Factor	Measurement	Limit	Margin	Detector	Comment
		MHz	dBuV	dB	dBuV/m	dBuV/m	dB		
1	*	5821.000	54.24	42.92	97.16	122.30	-25.14	peak	
2		5829.800	45.36	42.95	88.31	122.30	-33.99	AVG	
3		5850.000	10.91	43.03	53.94	122.30	-68.36	peak	
4		5850.000	0.75	43.03	43.78	122.30	-78.52	AVG	
5		5860.000	9.35	43.06	52.41	109.50	-57.09	peak	
6		5860.000	0.19	43.06	43.25	109.50	-66.25	AVG	

Orthogonal Axis:	X
Test Mode:	UNII-3/TX A Mode 5825MHz

Horizontal

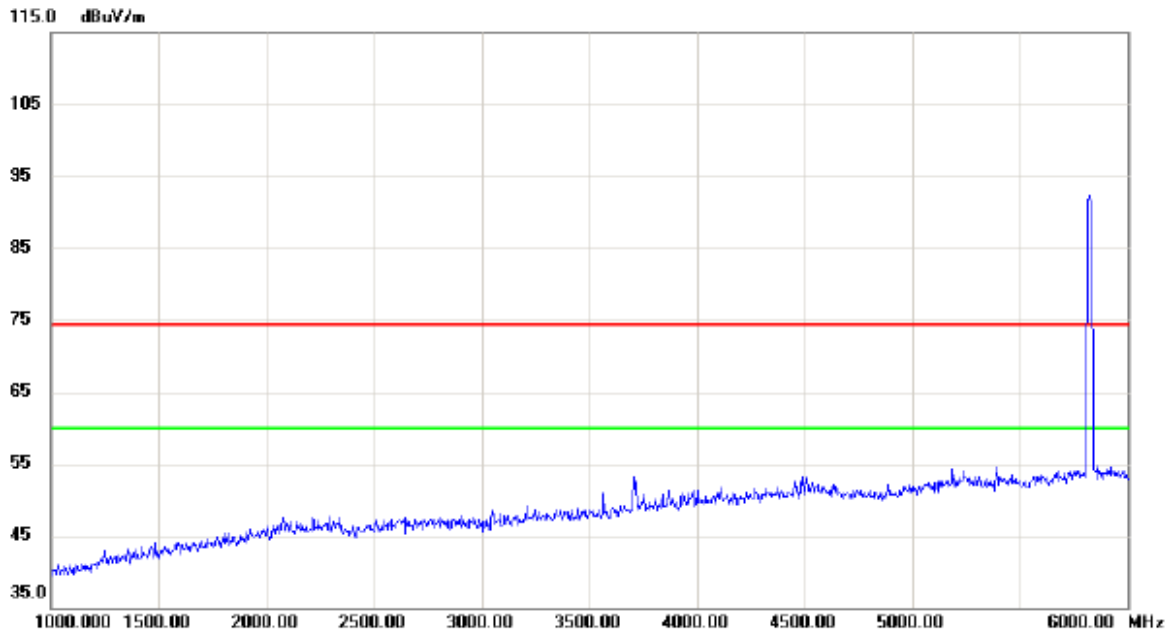

No.	Mk.	Freq.	Reading Level	Correct Factor	Measurement	Limit	Margin	Detector	Comment
		MHz	dBuV	dB	dBuV/m	dBuV/m	dB		

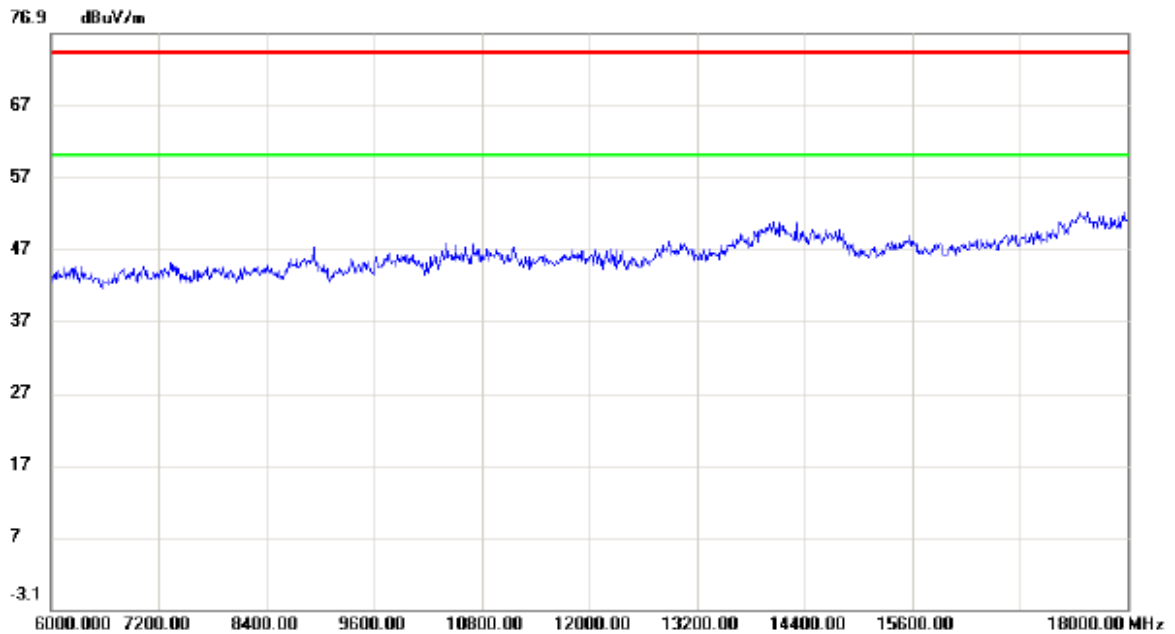

No.	Mk.	Freq.	Reading Level	Correct Factor	Measurement	Limit	Margin	Detector	Comment
		MHz	dBuV	dB	dBuV/m	dBuV/m	dB		

Orthogonal Axis:	X
Test Mode:	UNII-3/TX A Mode 5825MHz

Horizontal

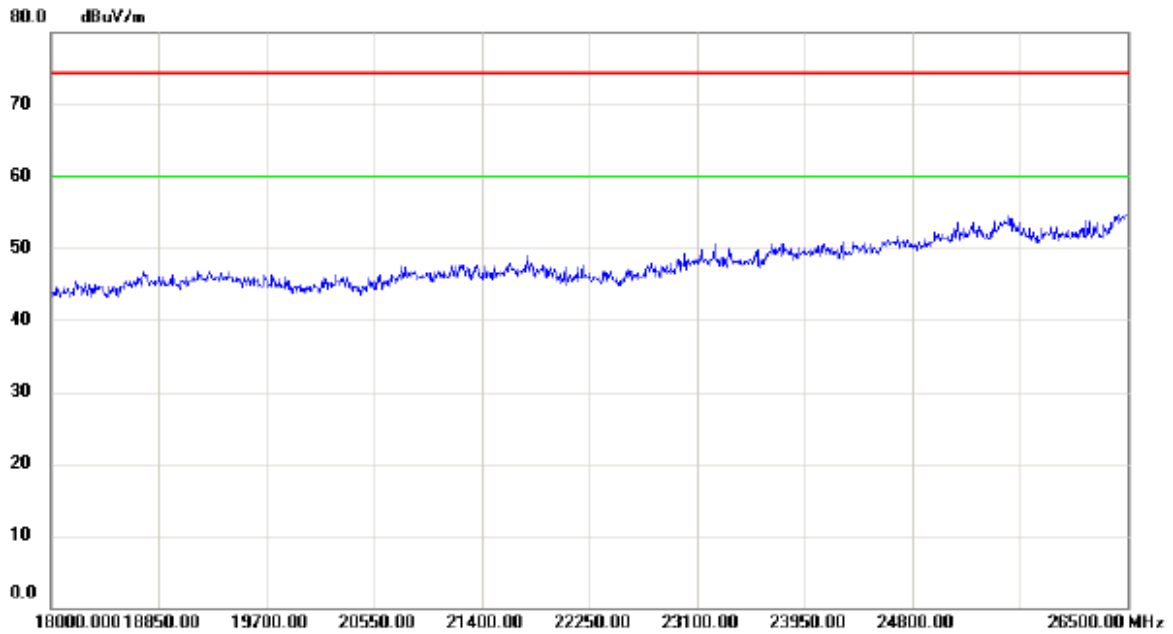

No.	Mk.	Freq.	Reading Level	Correct Factor	Measurement	Limit	Margin	Detector	Comment
		MHz	dBuV	dB	dBuV/m	dBuV/m	dB		

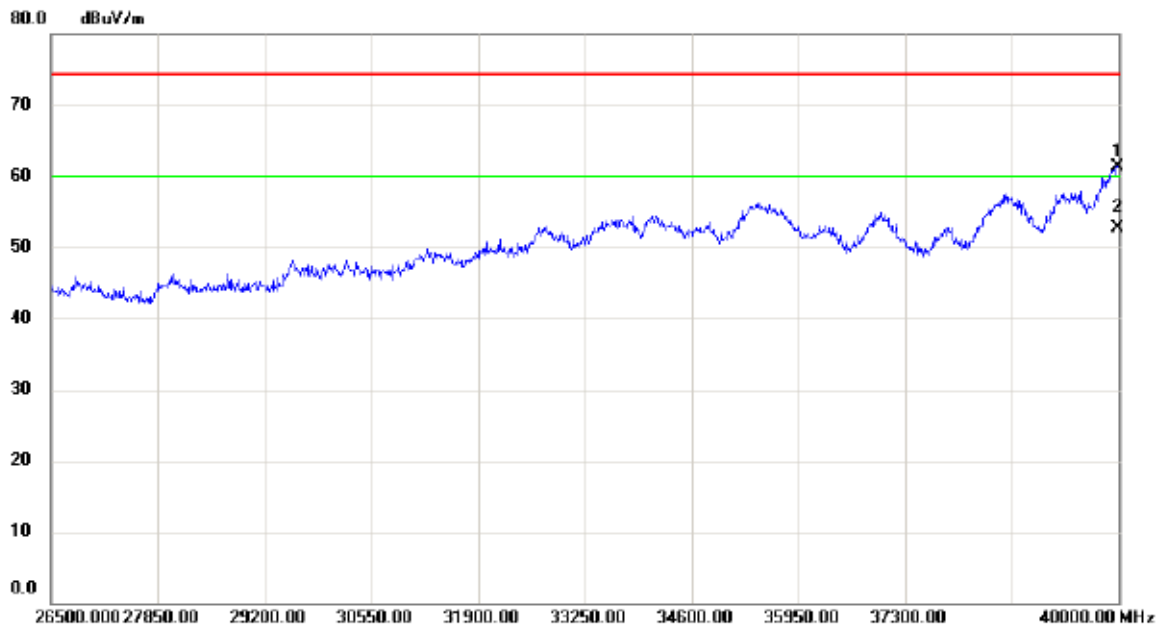

No.	Mk.	Freq.	Reading Level	Correct Factor	Measurement	Limit	Margin	Detector	Comment
		MHz	dBuV	dB	dBuV/m	dBuV/m	dB		
1		39986.50	45.50	15.86	61.36	74.30	-12.94	peak	
2	*	39986.09	36.86	15.86	52.72	60.00	-7.28	AVG	

Orthogonal Axis:	X
Test Mode:	UNII-3/TX N20 Mode 5745MHz

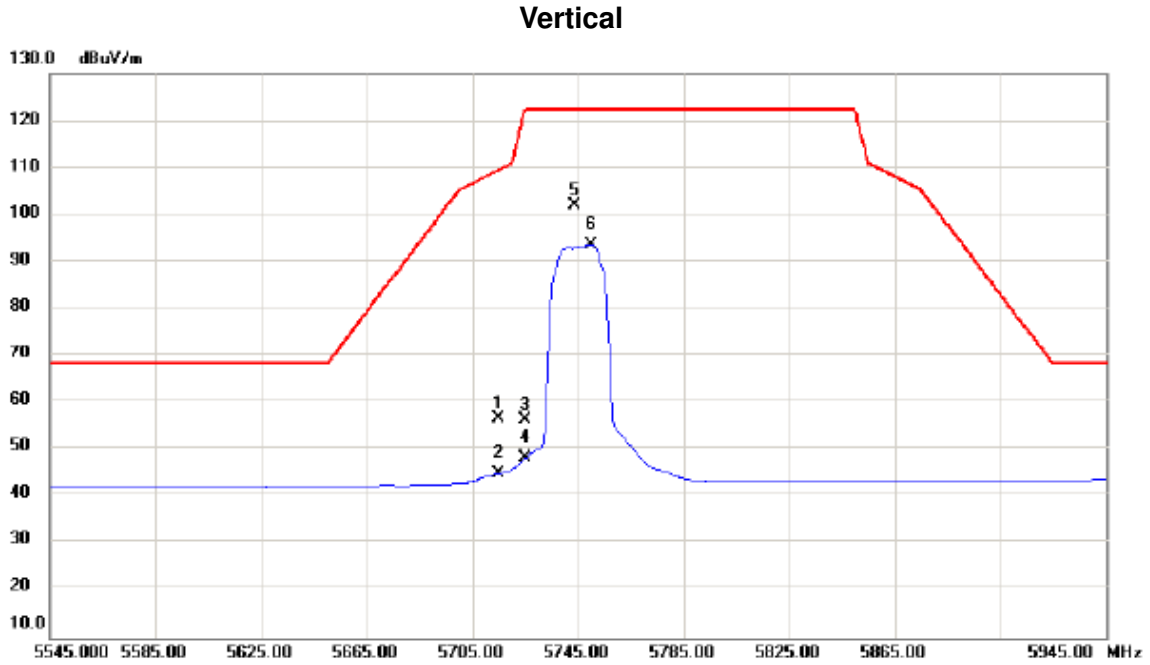

No.	Mk.	Freq.	Reading Level	Correct Factor	Measurement	Limit	Margin	Detector	Comment
		MHz	dBuV	dB	dBuV/m	dBuV/m	dB		
1		5715.000	14.08	42.55	56.63	109.50	-52.87	peak	
2		5715.000	2.43	42.55	44.98	109.50	-64.52	AVG	
3		5725.000	13.71	42.58	56.29	122.30	-66.01	peak	
4		5725.000	5.58	42.58	48.16	122.30	-74.14	AVG	
5	*	5743.800	59.43	42.65	102.08	122.30	-20.22	peak	
6		5750.200	50.93	42.67	93.60	122.30	-28.70	AVG	

Orthogonal Axis:	X
Test Mode:	UNII-3/TX N20 Mode 5745MHz

Vertical

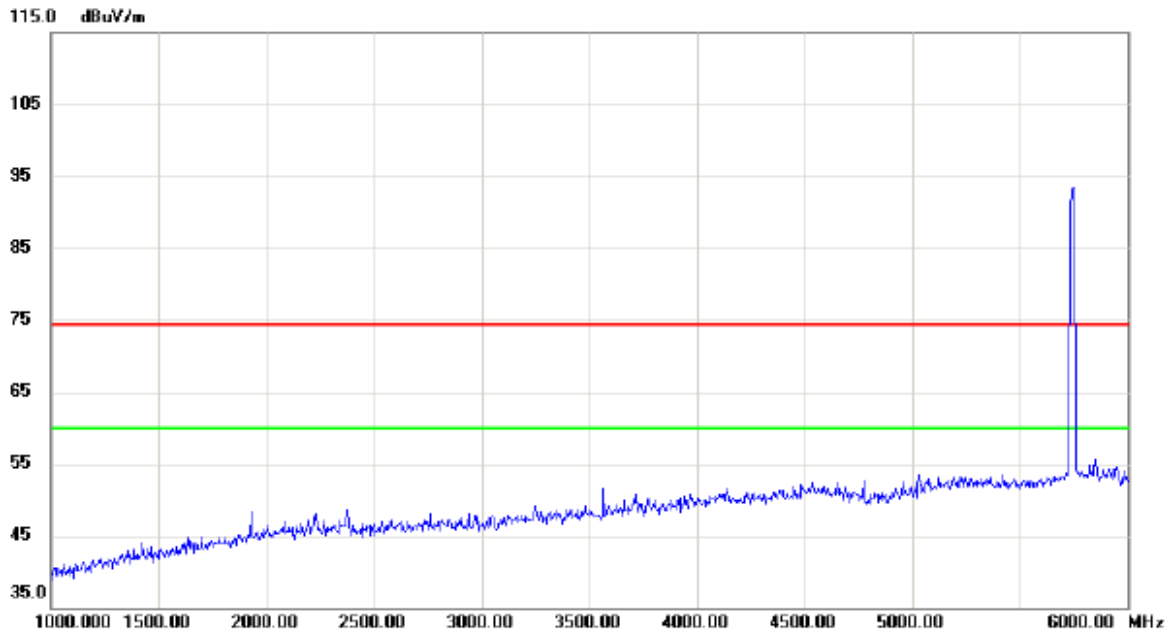

No.	Mk.	Freq.	Reading Level	Correct Factor	Measurement	Limit	Margin	Detector	Comment
		MHz	dBuV	dB	dBuV/m	dBuV/m	dB		

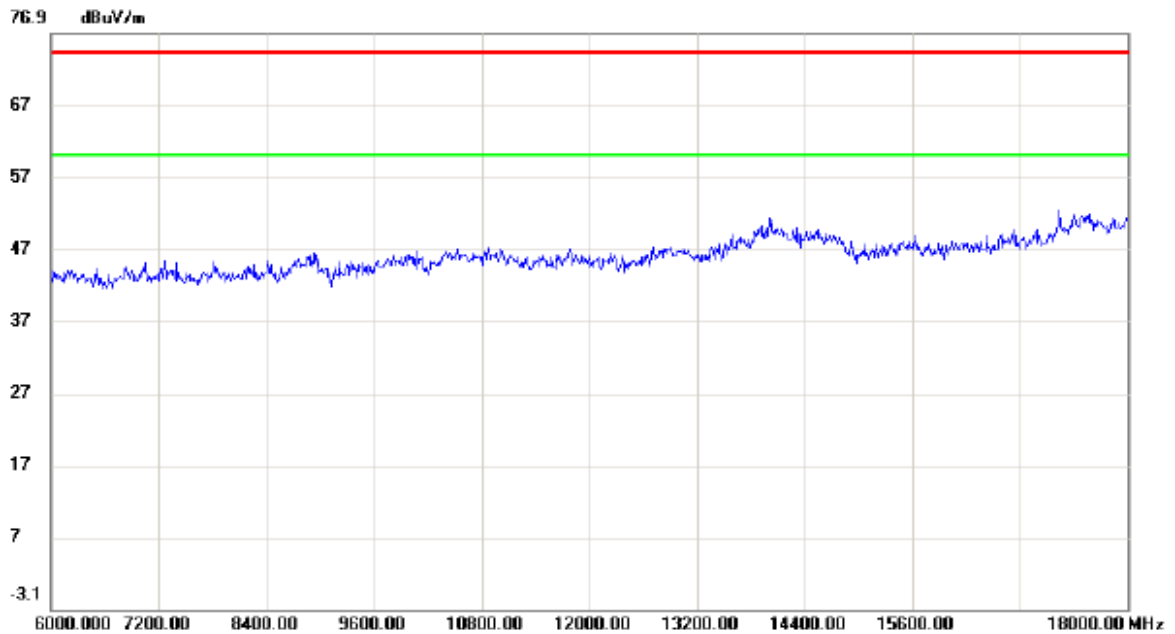

No.	Mk.	Freq.	Reading Level	Correct Factor	Measurement	Limit	Margin	Detector	Comment
		MHz	dBuV	dB	dBuV/m	dBuV/m	dB		

Orthogonal Axis:	X
Test Mode:	UNII-3/TX N20 Mode 5745MHz

Vertical

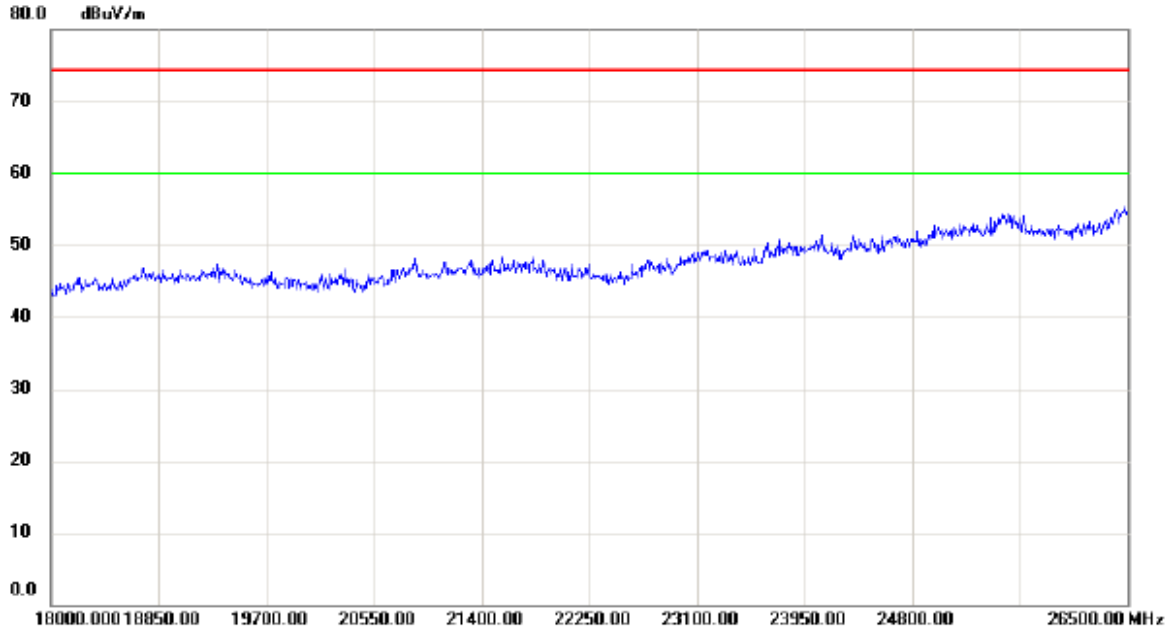

No.	Mk.	Freq.	Reading Level	Correct Factor	Measurement	Limit	Margin	Detector	Comment
		MHz	dBuV	dB	dBuV/m	dBuV/m	dB		

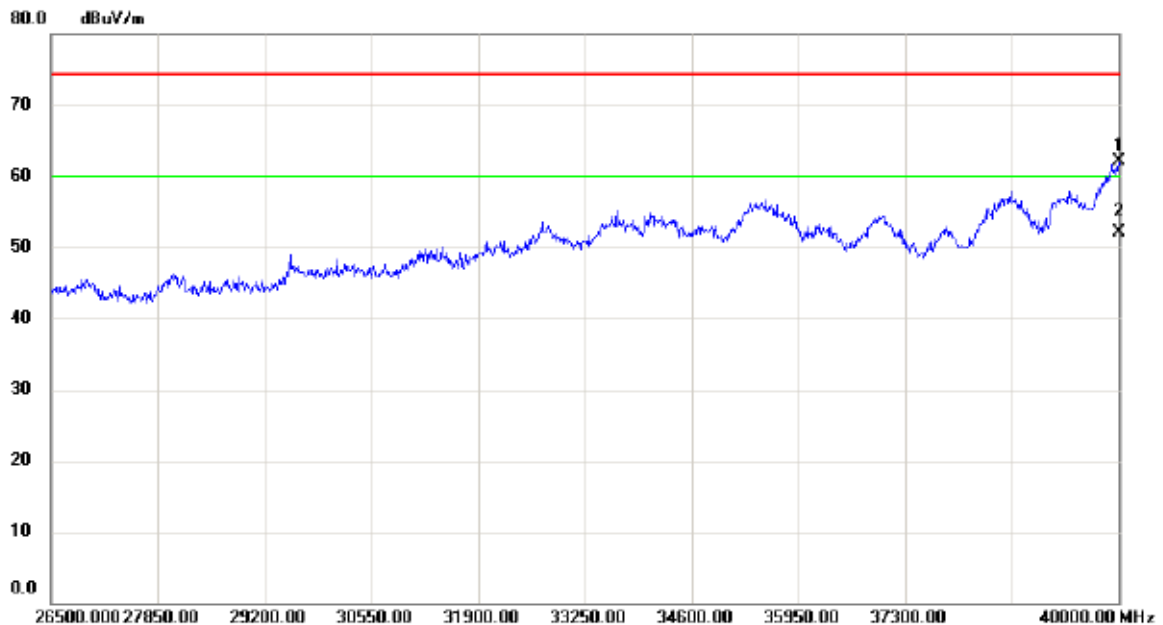

No.	Mk.	Freq.	Reading Level	Correct Factor	Measurement	Limit	Margin	Detector	Comment
		MHz	dBuV	dB	dBuV/m	dBuV/m	dB		
1		40000.00	46.23	15.89	62.12	74.30	-12.18	peak	
2	*	40000.00	36.25	15.89	52.14	60.00	-7.86	AVG	

Orthogonal Axis:	X
Test Mode:	UNII-3/TX N20 Mode 5745MHz

Horizontal

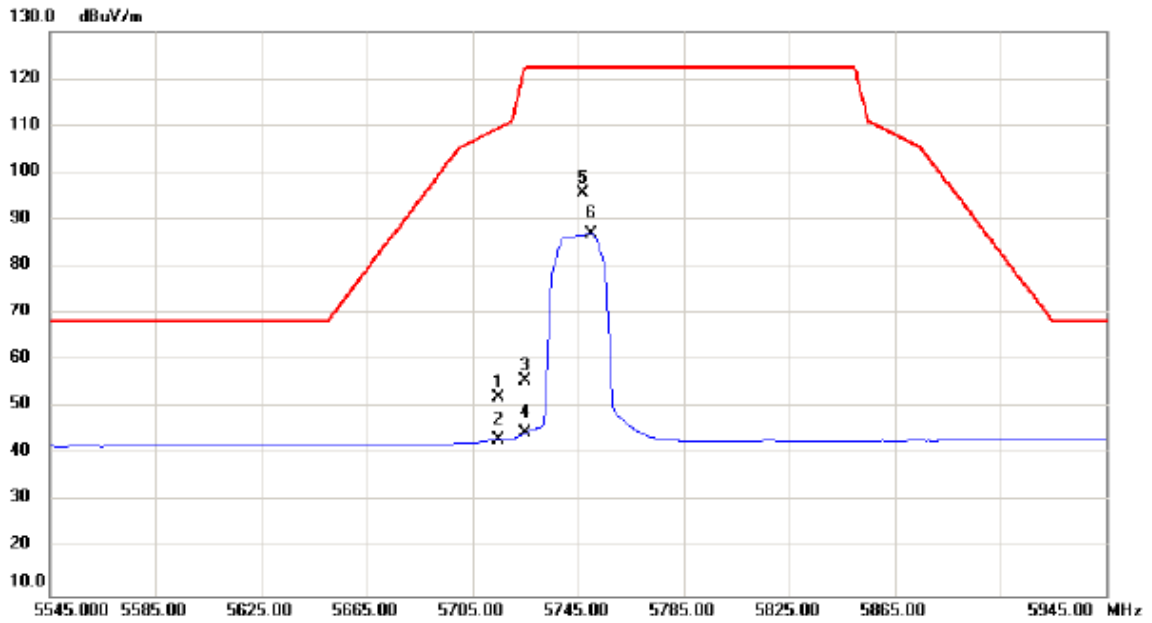

No.	Mk.	Freq.	Reading Level	Correct Factor	Measurement	Limit	Margin	Detector	Comment
		MHz	dBuV	dB	dBuV/m	dBuV/m	dB		
1		5715.000	9.66	42.55	52.21	109.50	-57.29	peak	
2		5715.000	0.67	42.55	43.22	109.50	-66.28	AVG	
3		5725.000	13.29	42.58	55.87	122.30	-66.43	peak	
4		5725.000	2.08	42.58	44.66	122.30	-77.64	AVG	
5	*	5747.000	52.96	42.66	95.62	122.30	-26.68	peak	
6		5750.200	44.38	42.67	87.05	122.30	-35.25	AVG	

Orthogonal Axis:	X
Test Mode:	UNII-3/TX N20 Mode 5745MHz

Horizontal

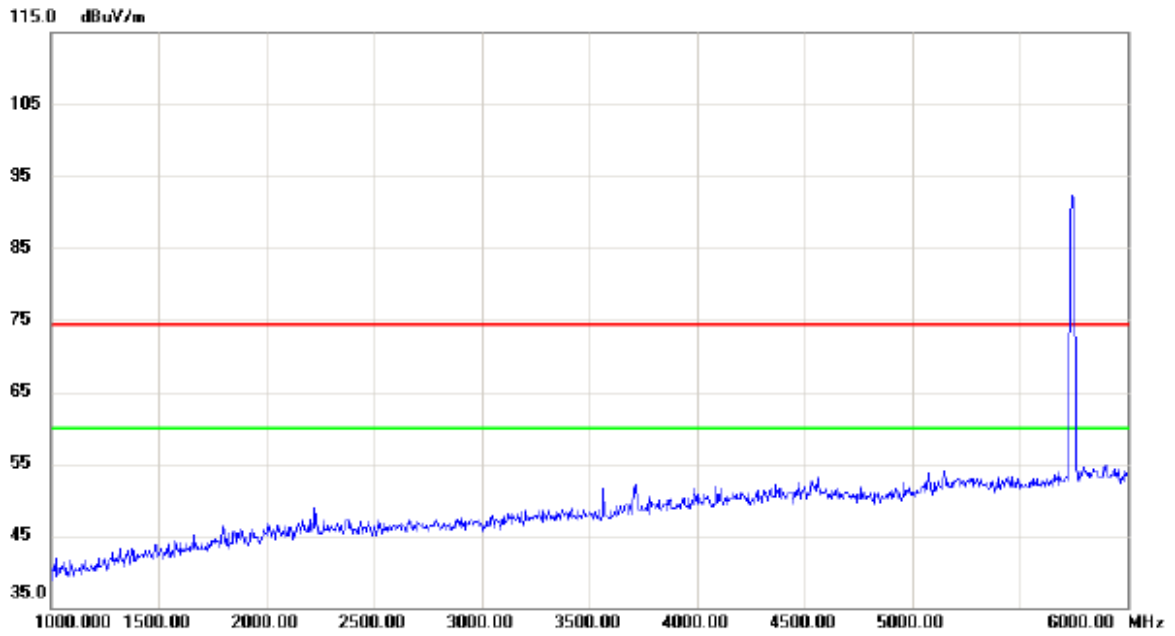

No.	Mk.	Freq.	Reading Level	Correct Factor	Measurement	Limit	Margin	Detector	Comment
		MHz	dBuV	dB	dBuV/m	dBuV/m	dB		

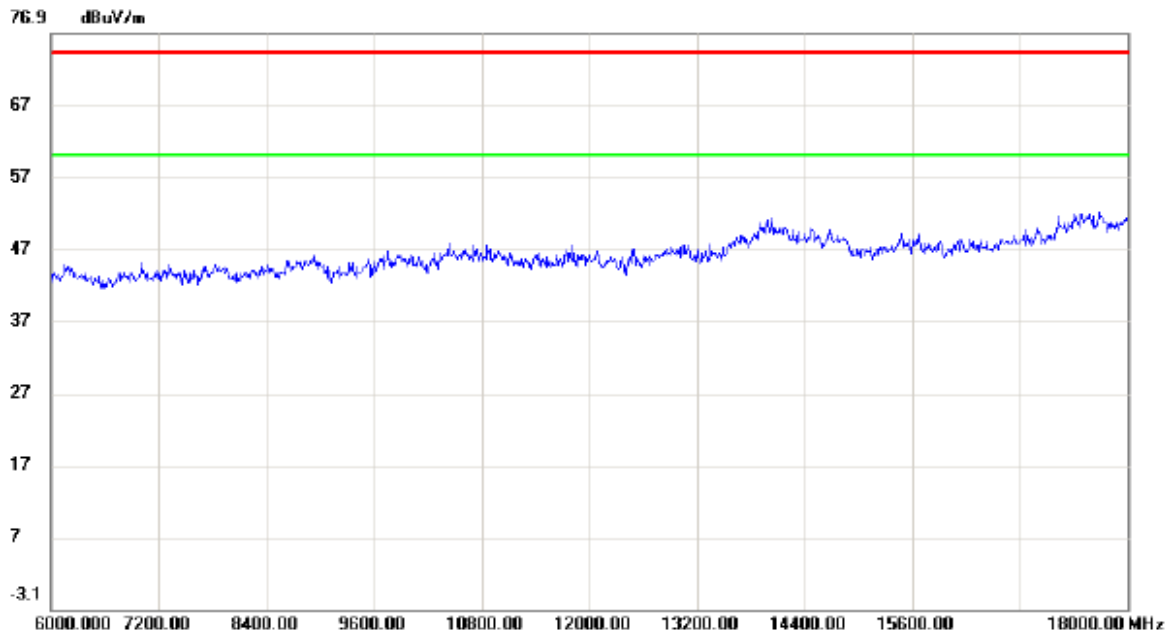

No.	Mk.	Freq.	Reading Level	Correct Factor	Measurement	Limit	Margin	Detector	Comment
		MHz	dBuV	dB	dBuV/m	dBuV/m	dB		

Orthogonal Axis:	X
Test Mode:	UNII-3/TX N20 Mode 5745MHz

Horizontal

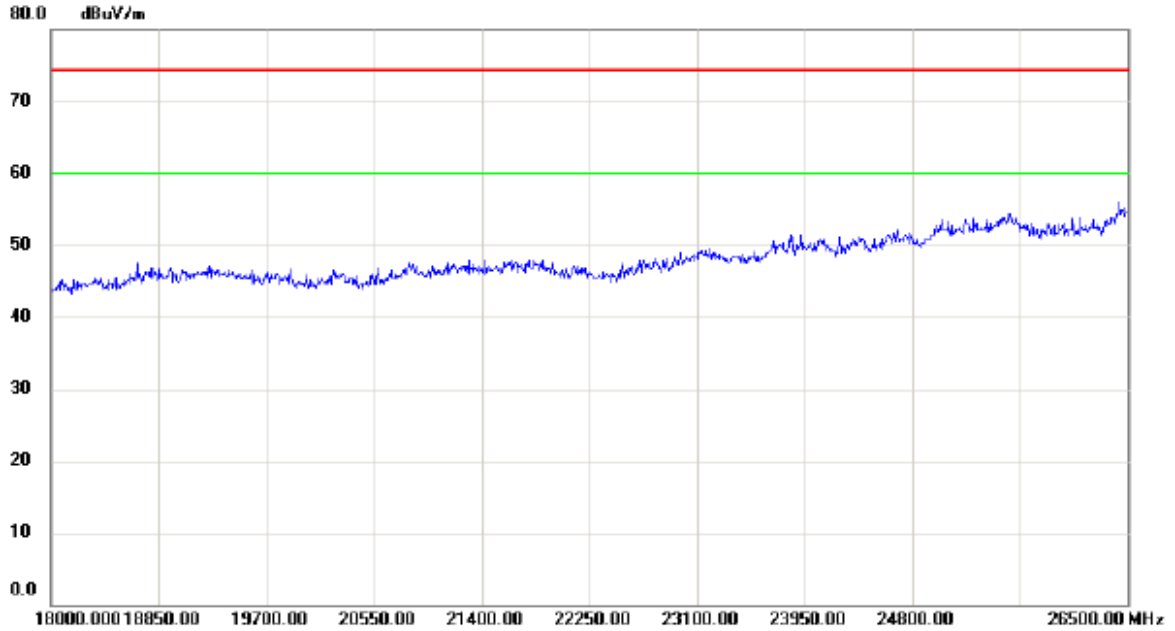

No.	Mk.	Freq.	Reading Level	Correct Factor	Measurement	Limit	Margin	Detector	Comment
		MHz	dBuV	dB	dBuV/m	dBuV/m	dB		

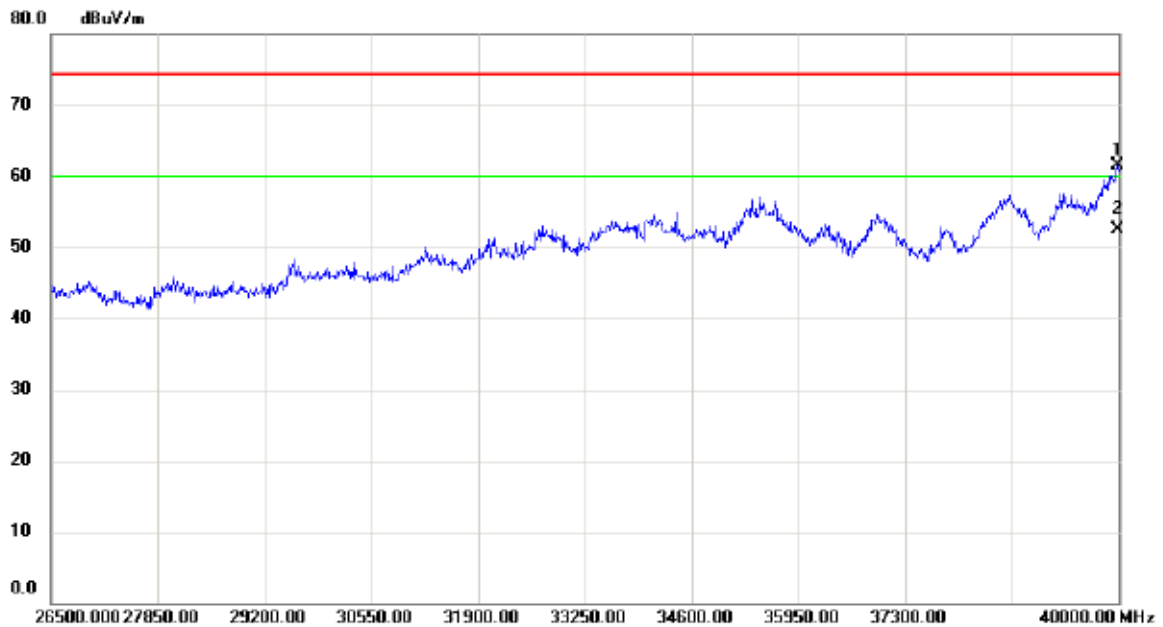

No.	Mk.	Freq.	Reading Level	Correct Factor	Measurement	Limit	Margin	Detector	Comment
		MHz	dBuV	dB	dBuV/m	dBuV/m	dB		
1		39986.50	45.70	15.86	61.56	74.30	-12.74	peak	
2	*	39986.68	36.59	15.86	52.45	60.00	-7.55	AVG	

Orthogonal Axis:	X
Test Mode:	UNII-3/TX N20 Mode 5825MHz

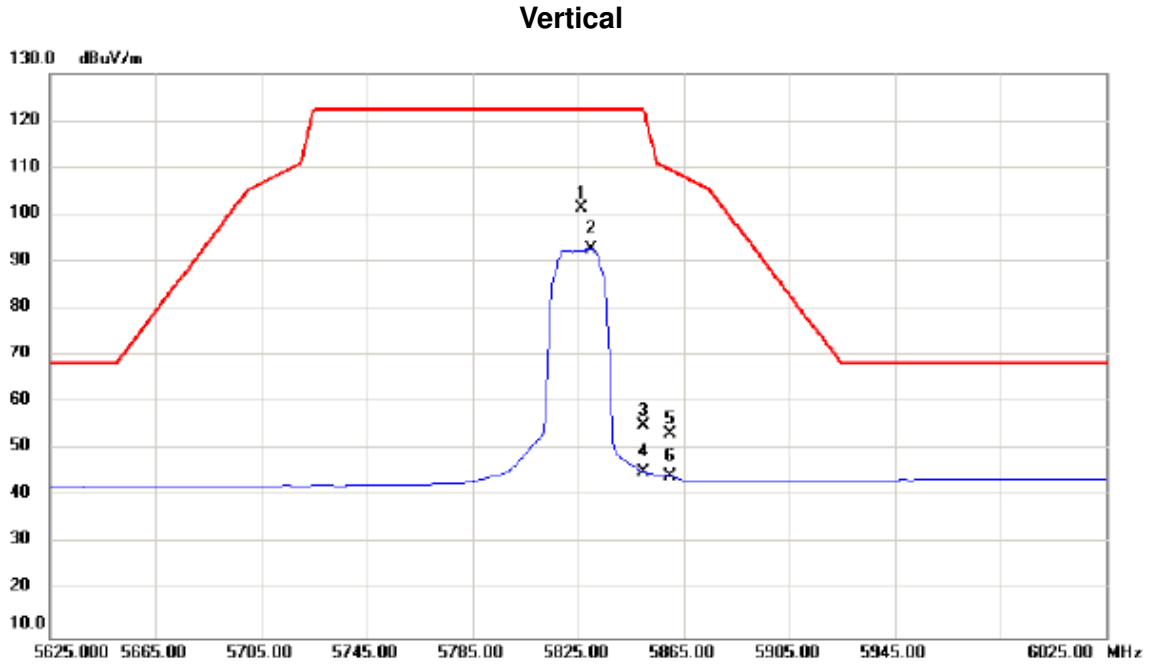

No.	Mk.	Freq.	Reading	Correct	Measure-	Limit	Margin		
		MHz	Level	Factor	ment			Detector	Comment
			dBuV	dB	dBuV/m	dBuV/m	dB		
1	*	5826.200	58.55	42.94	101.49	122.30	-20.81	peak	
2		5830.200	49.76	42.95	92.71	122.30	-29.59	AVG	
3		5850.000	12.06	43.03	55.09	122.30	-67.21	peak	
4		5850.000	2.22	43.03	45.25	122.30	-77.05	AVG	
5		5860.000	10.42	43.06	53.48	109.50	-56.02	peak	
6		5860.000	1.30	43.06	44.36	109.50	-65.14	AVG	

Orthogonal Axis:	X
Test Mode:	UNII-3/TX N20 Mode 5825MHz

Vertical

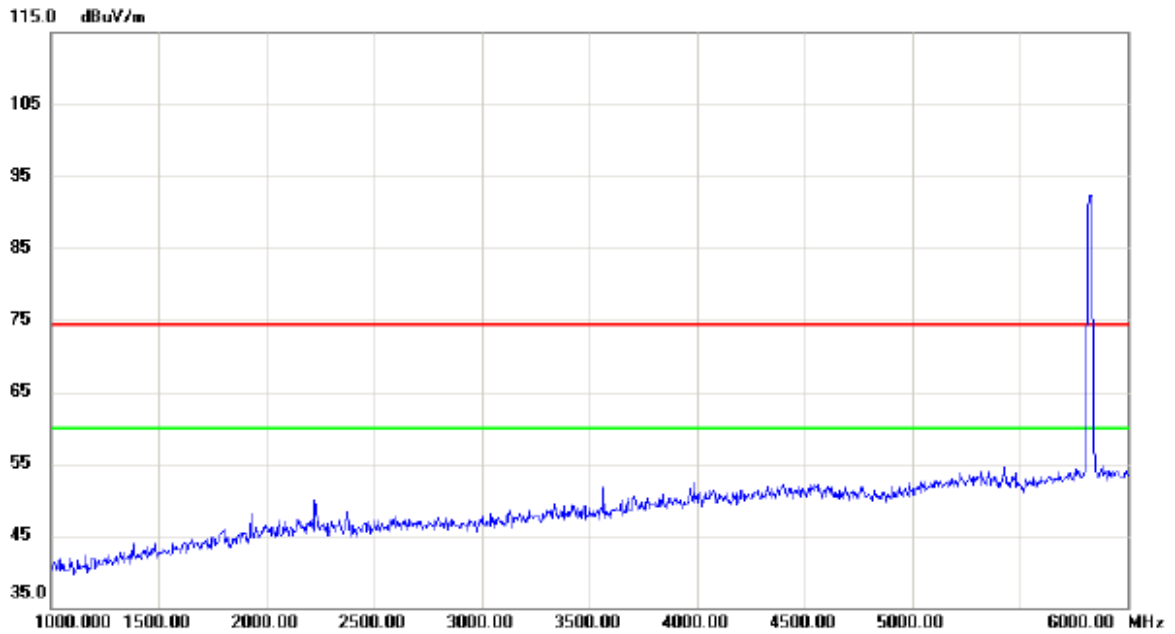

No.	Mk.	Freq.	Reading Level	Correct Factor	Measurement	Limit	Margin	Detector	Comment
		MHz	dBuV	dB	dBuV/m	dBuV/m	dB		

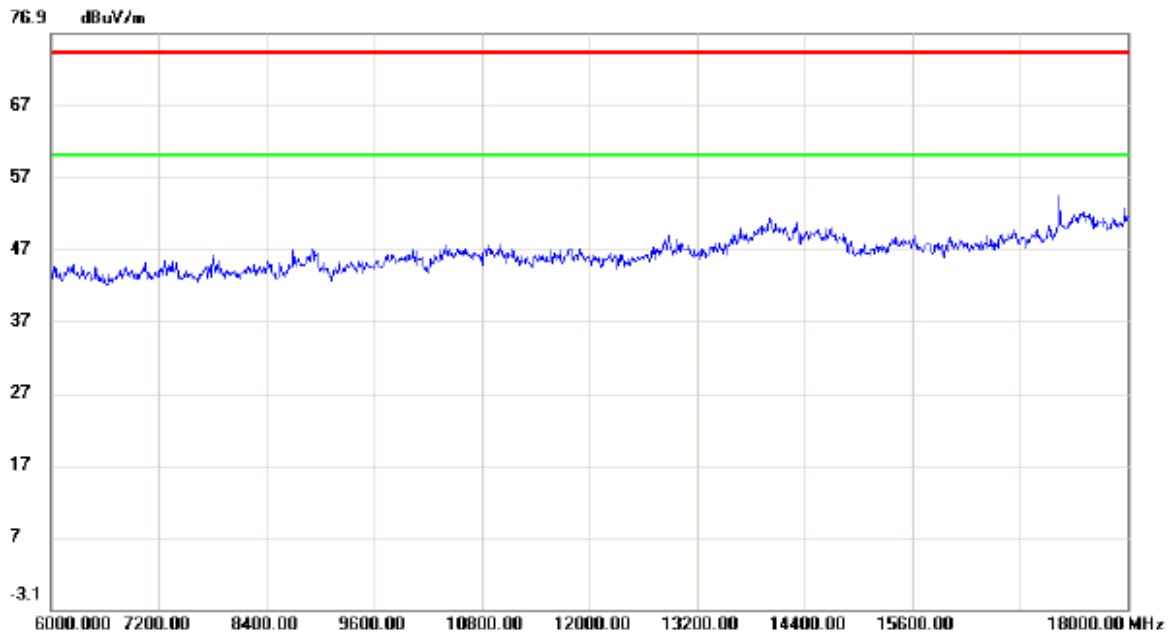

No.	Mk.	Freq.	Reading Level	Correct Factor	Measurement	Limit	Margin	Detector	Comment
		MHz	dBuV	dB	dBuV/m	dBuV/m	dB		

Orthogonal Axis:	X
Test Mode:	UNII-3/TX N20 Mode 5825MHz

Vertical

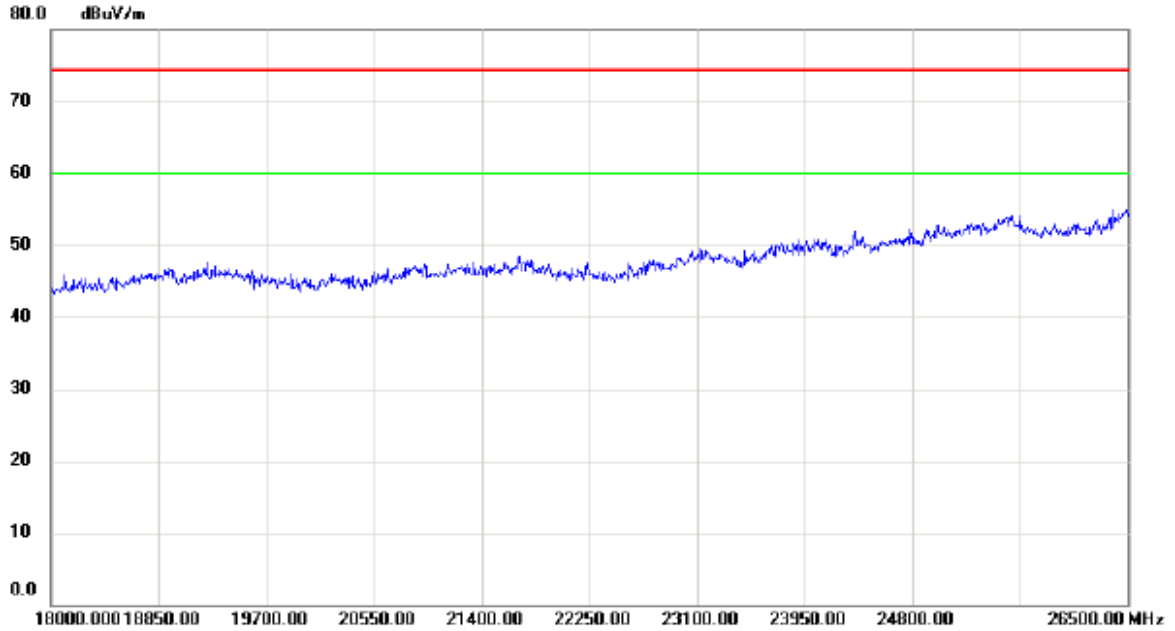

No.	Mk.	Freq.	Reading Level	Correct Factor	Measurement	Limit	Margin	Detector	Comment
		MHz	dBuV	dB	dBuV/m	dBuV/m	dB		

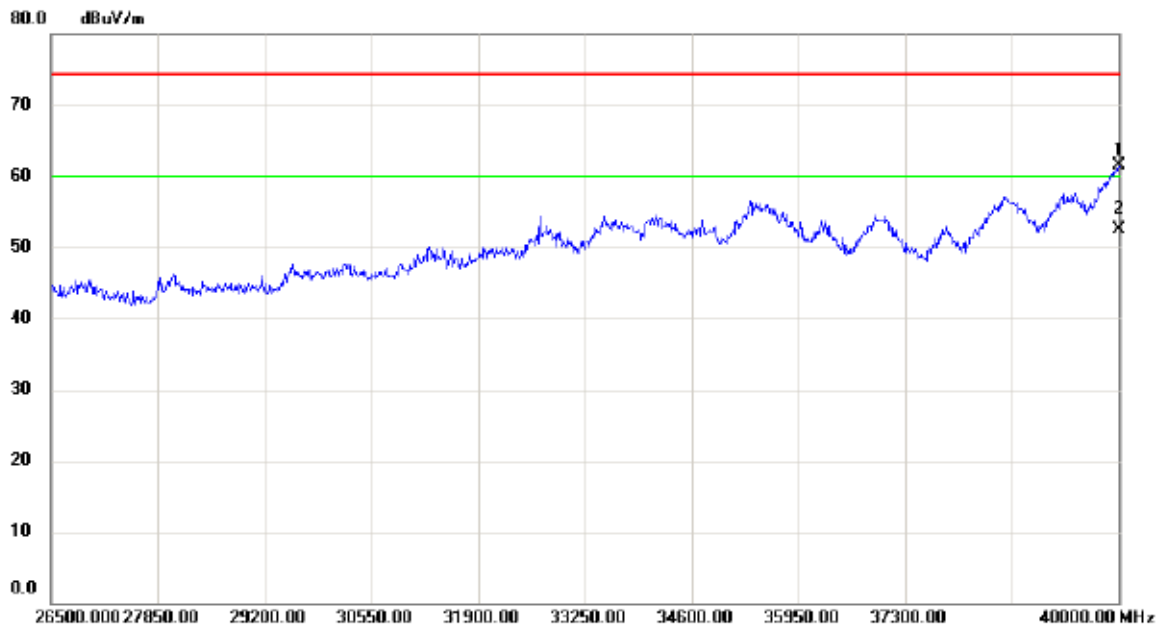

No.	Mk.	Freq.	Reading Level	Correct Factor	Measurement	Limit	Margin	Detector	Comment
		MHz	dBuV	dB	dBuV/m	dBuV/m	dB		
1		40000.00	45.52	15.89	61.41	74.30	-12.89	peak	
2	*	40000.00	36.62	15.89	52.51	60.00	-7.49	AVG	

Orthogonal Axis:	X
Test Mode:	UNII-3/TX N20 Mode 5825MHz

Horizontal

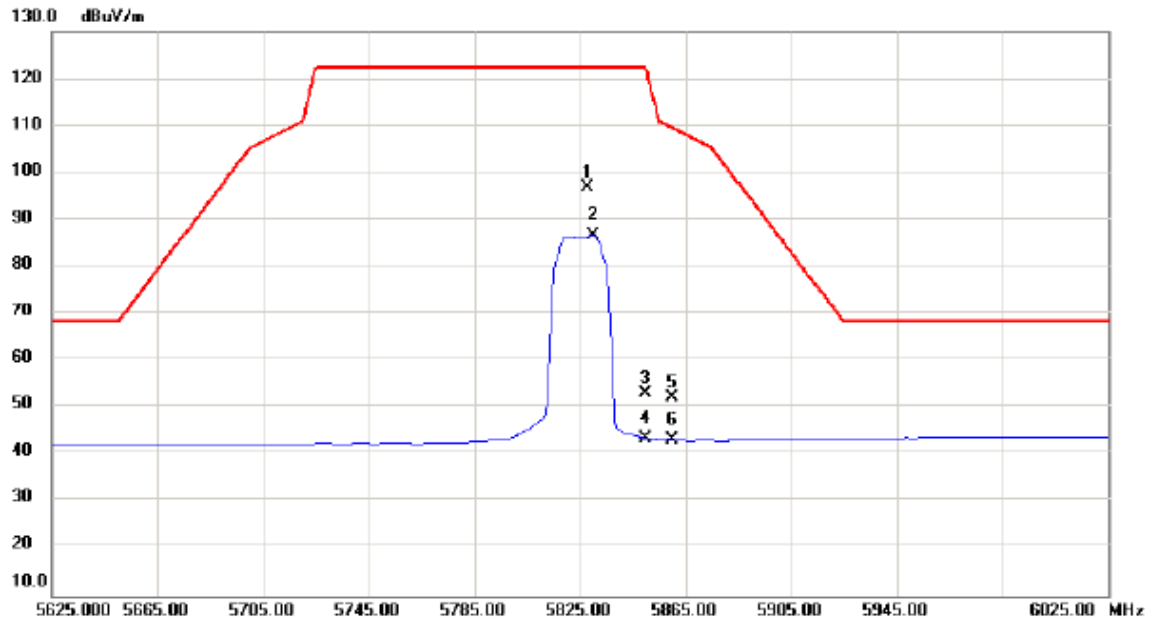

No.	Mk.	Freq.	Reading	Correct	Measure-	Limit	Margin		
		MHz	dBuV	Factor	ment	dBuV/m	dB	Detector	Comment
				dB	dBuV/m				
1	*	5828.200	53.83	42.95	96.78	122.30	-25.52	peak	
2		5830.200	43.64	42.95	86.59	122.30	-35.71	AVG	
3		5850.000	10.11	43.03	53.14	122.30	-69.16	peak	
4		5850.000	0.42	43.03	43.45	122.30	-78.85	AVG	
5		5860.000	9.10	43.06	52.16	109.50	-57.34	peak	
6		5860.000	0.19	43.06	43.25	109.50	-66.25	AVG	

Orthogonal Axis:	X
Test Mode:	UNII-3/TX N20 Mode 5825MHz

Horizontal

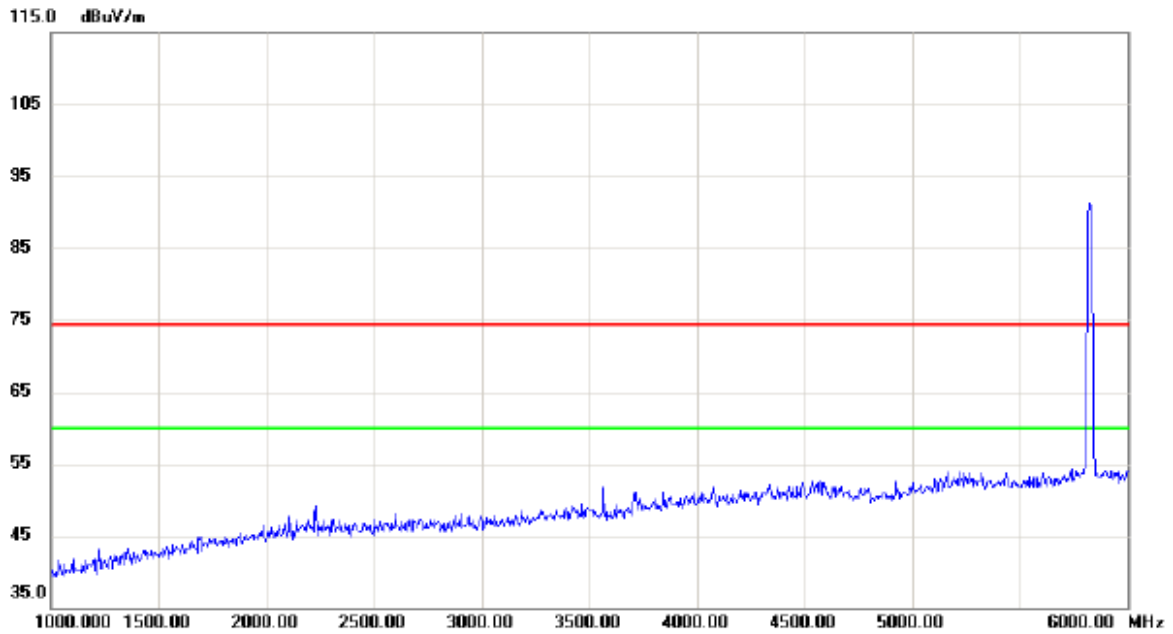

No.	Mk.	Freq.	Reading Level	Correct Factor	Measurement	Limit	Margin	Detector	Comment
		MHz	dBuV	dB	dBuV/m	dBuV/m	dB		

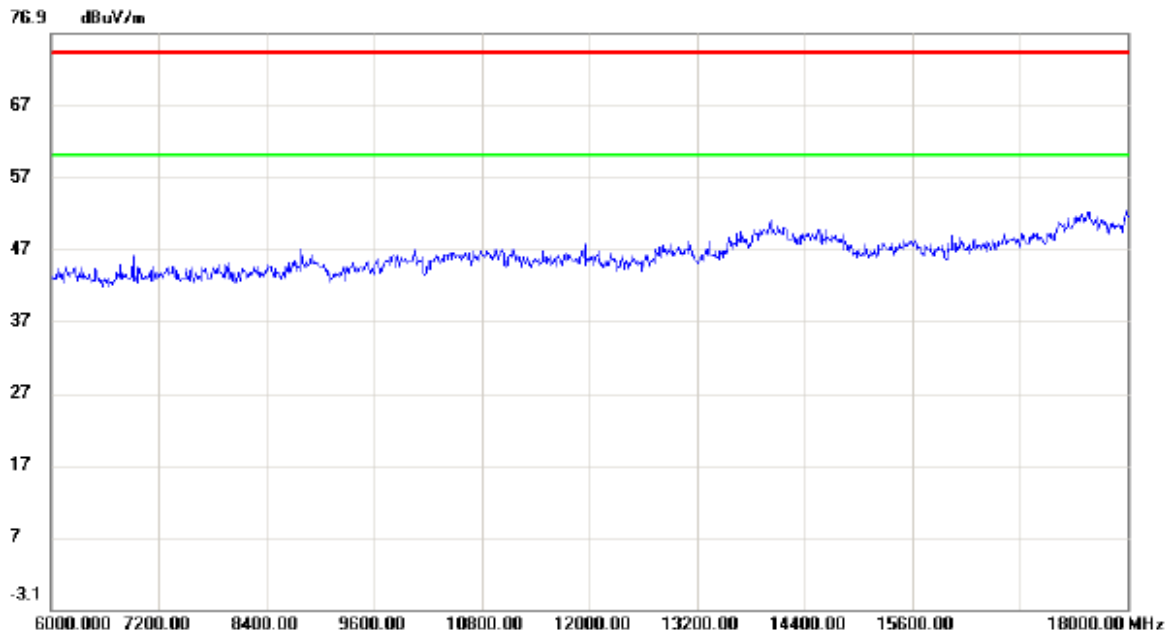

No.	Mk.	Freq.	Reading Level	Correct Factor	Measurement	Limit	Margin	Detector	Comment
		MHz	dBuV	dB	dBuV/m	dBuV/m	dB		

Orthogonal Axis:	X
Test Mode:	UNII-3/TX N20 Mode 5825MHz

Horizontal

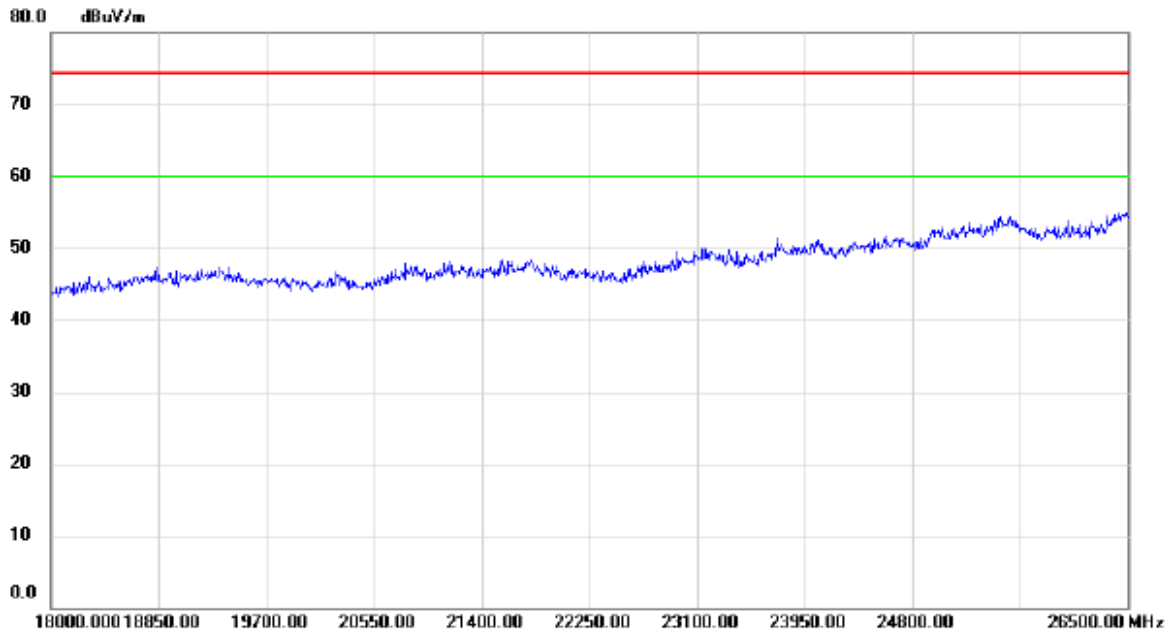

No.	Mk.	Freq.	Reading Level	Correct Factor	Measurement	Limit	Margin	Detector	Comment
		MHz	dBuV	dB	dBuV/m	dBuV/m	dB		

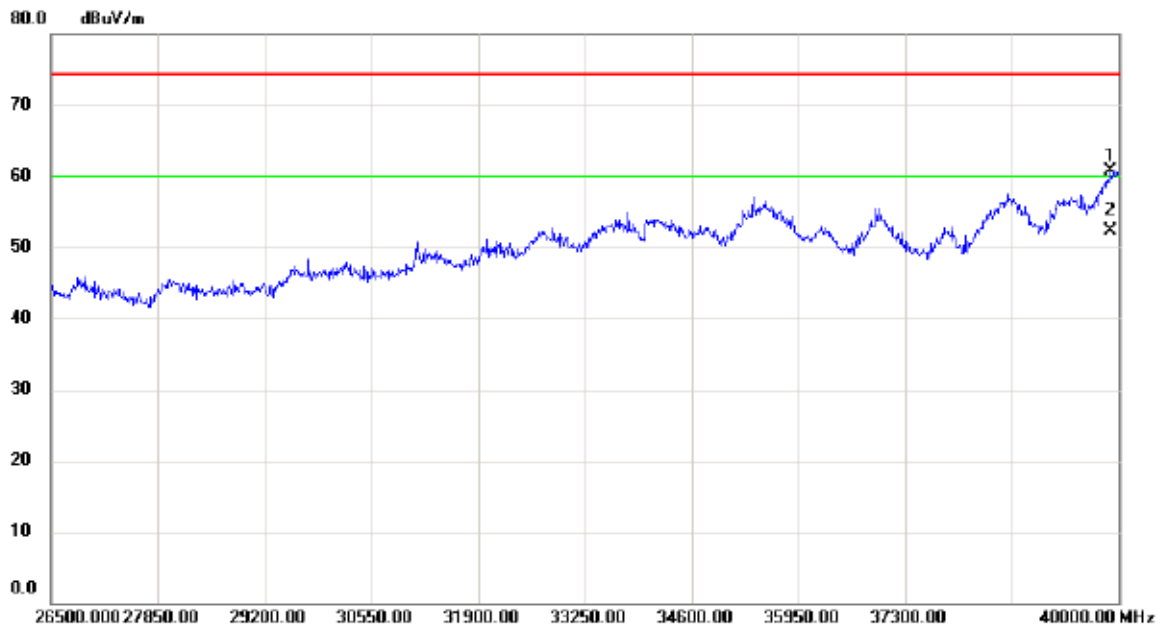

No.	Mk.	Freq.	Reading Level	Correct Factor	Measurement	Limit	Margin	Detector	Comment
		MHz	dBuV	dB	dBuV/m	dBuV/m	dB		
1		39905.50	44.99	15.73	60.72	74.30	-13.58	peak	
2	*	39905.51	36.52	15.73	52.25	60.00	-7.75	AVG	

Orthogonal Axis:	X
Test Mode:	UNII-3/TX N40 Mode 5755MHz

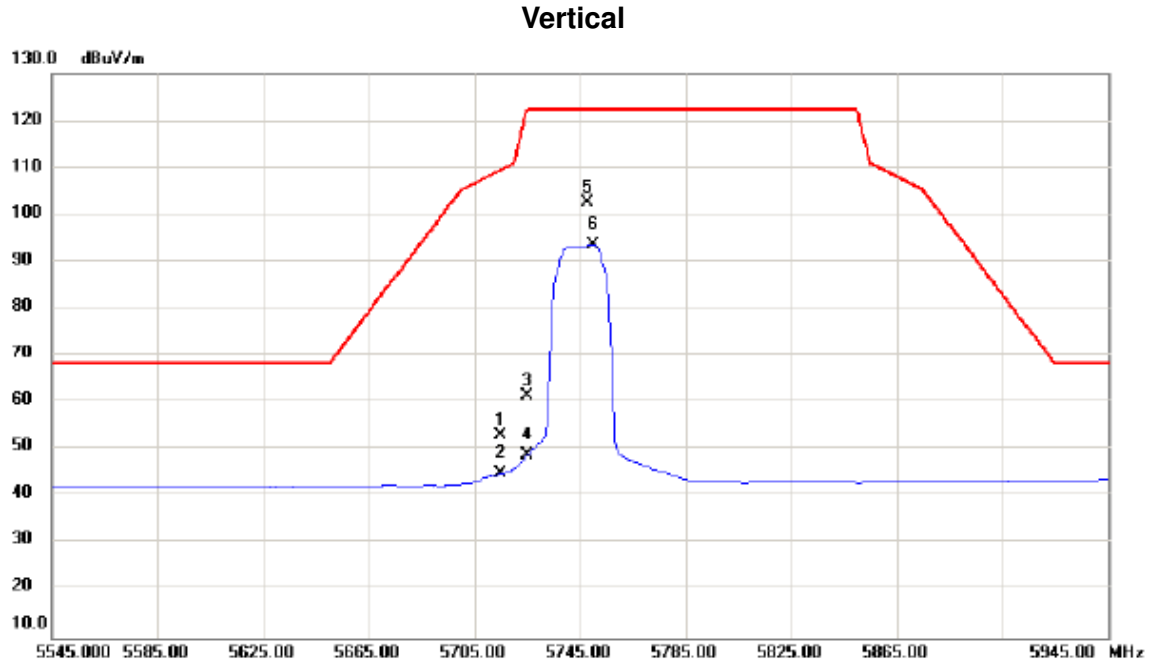

No.	Mk.	Freq. MHz	Reading Level dBuV	Correct Factor dB	Measure- ment dBuV/m	Limit dBuV/m	Margin dB	Detector	Comment
1		5715.000	10.47	42.55	53.02	109.50	-56.48	peak	
2		5715.000	2.37	42.55	44.92	109.50	-64.58	AVG	
3		5725.000	18.93	42.58	61.51	122.30	-60.79	peak	
4		5725.000	6.13	42.58	48.71	122.30	-73.59	AVG	
5	*	5748.200	59.79	42.67	102.46	122.30	-19.84	peak	
6		5750.200	50.99	42.67	93.66	122.30	-28.64	AVG	

Orthogonal Axis:	X
Test Mode:	UNII-3/TX N40 Mode 5755MHz

Vertical

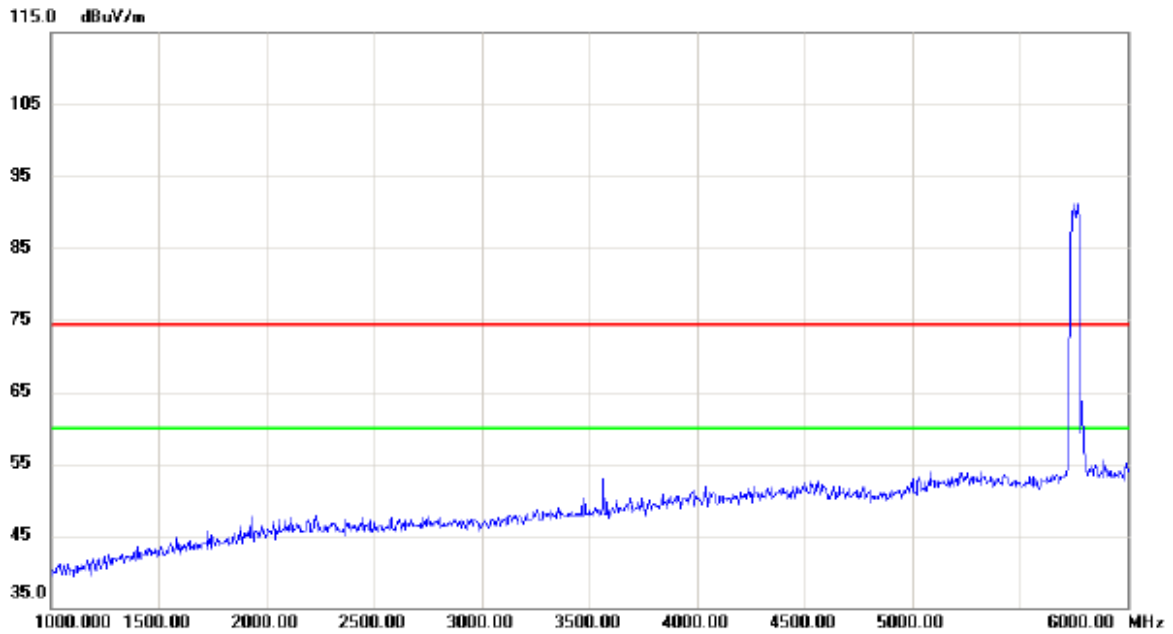

No.	Mk.	Freq.	Reading Level	Correct Factor	Measurement	Limit	Margin	Detector	Comment
		MHz	dBuV	dB	dBuV/m	dBuV/m	dB		

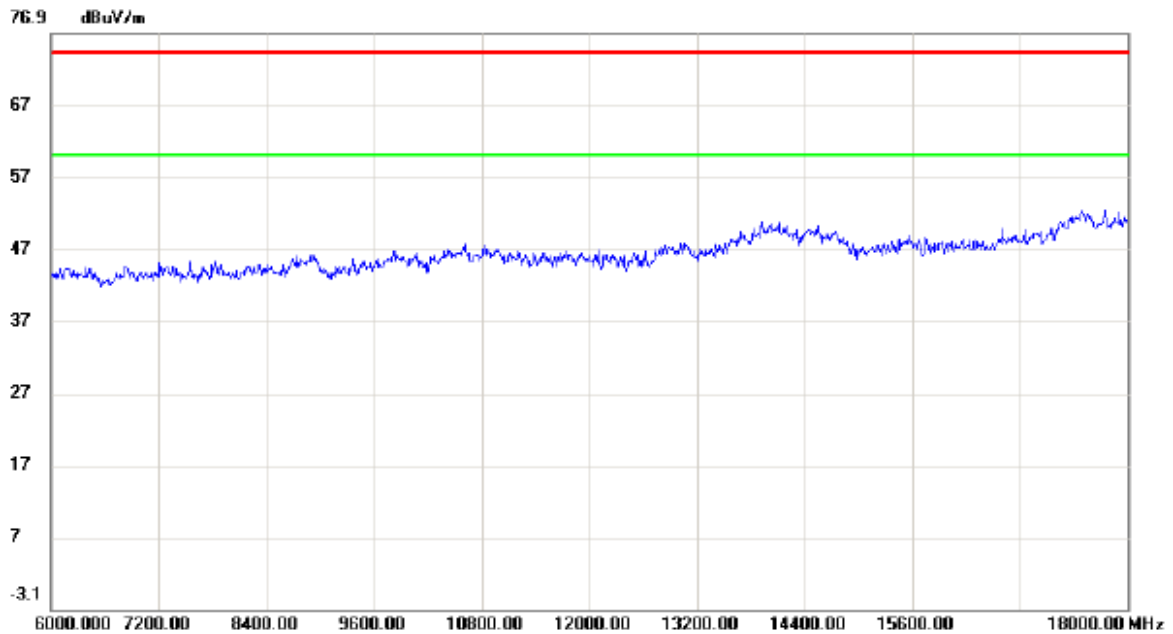

No.	Mk.	Freq.	Reading Level	Correct Factor	Measurement	Limit	Margin	Detector	Comment
		MHz	dBuV	dB	dBuV/m	dBuV/m	dB		

Orthogonal Axis:	X
Test Mode:	UNII-3/TX N40 Mode 5755MHz

Vertical

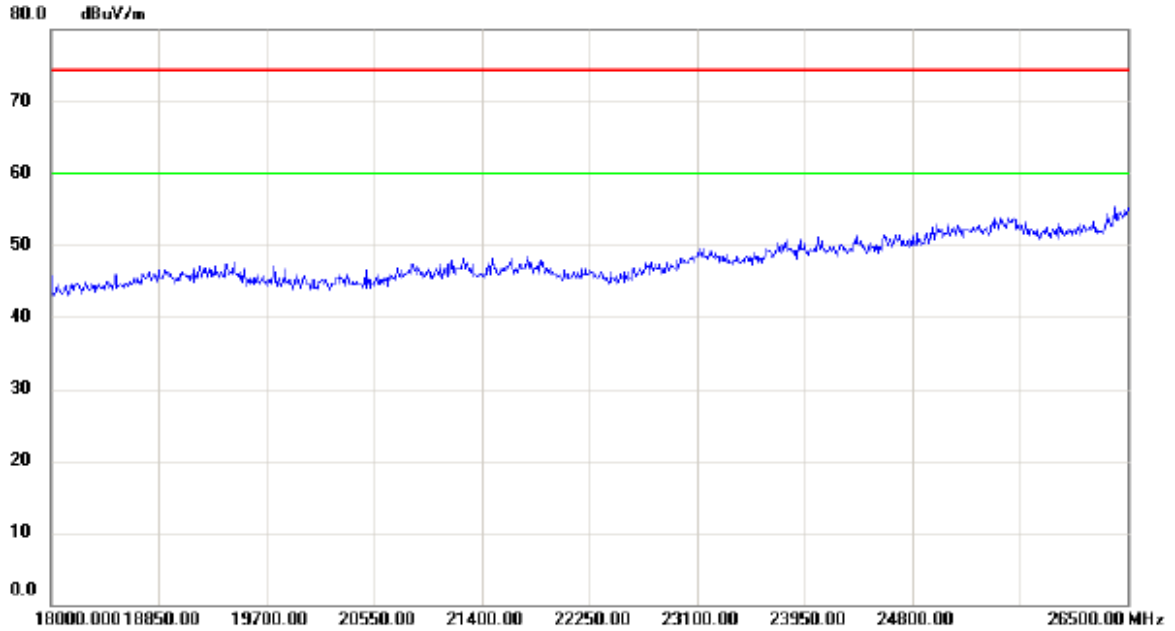

No.	Mk.	Freq.	Reading Level	Correct Factor	Measurement	Limit	Margin	Detector	Comment
		MHz	dBuV	dB	dBuV/m	dBuV/m	dB		

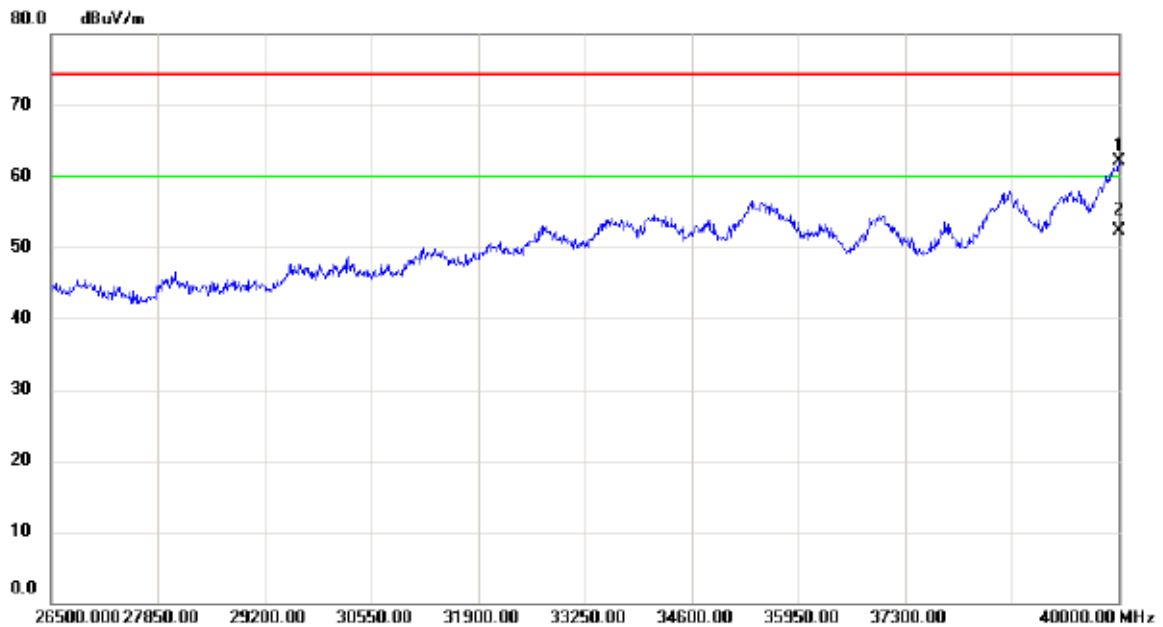

No.	Mk.	Freq.	Reading Level	Correct Factor	Measurement	Limit	Margin	Detector	Comment
		MHz	dBuV	dB	dBuV/m	dBuV/m	dB		
1		40000.00	46.30	15.89	62.19	74.30	-12.11	peak	
2	*	40000.00	36.51	15.89	52.40	60.00	-7.60	AVG	

Orthogonal Axis:	X
Test Mode:	UNII-3/TX N40 Mode 5755MHz

Horizontal

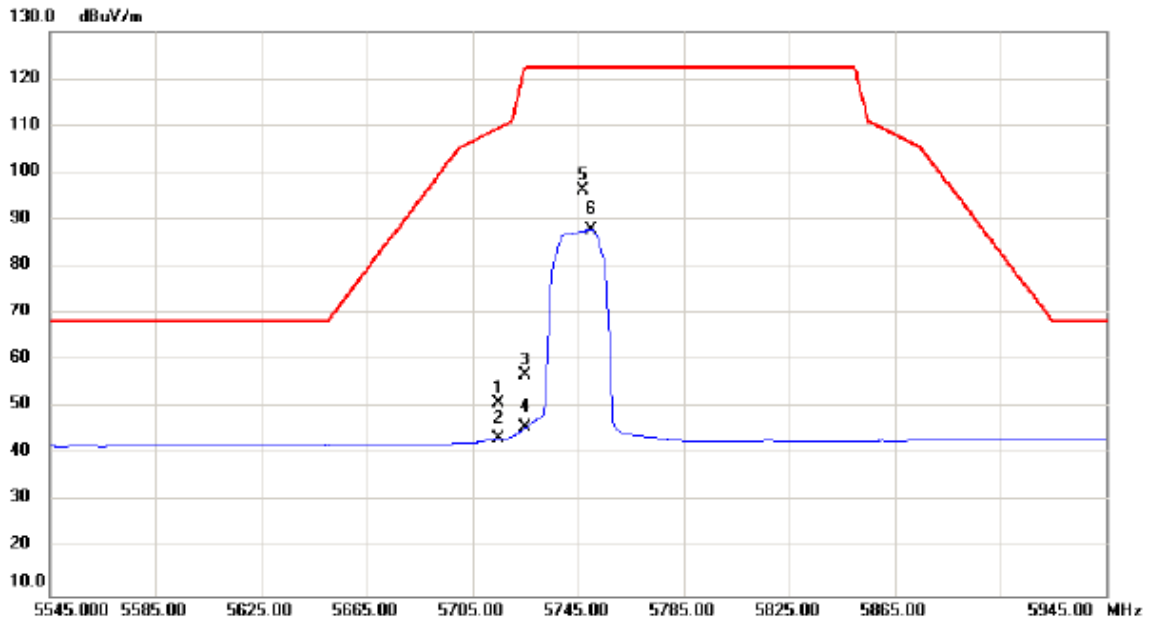

No.	Mk.	Freq. MHz	Reading Level dBuV	Correct Factor dB	Measure- ment dBuV/m	Limit dBuV/m	Margin dB	Detector	Comment
1		5715.000	8.36	42.55	50.91	109.50	-58.59	peak	
2		5715.000	0.83	42.55	43.38	109.50	-66.12	AVG	
3		5725.000	14.47	42.58	57.05	122.30	-65.25	peak	
4		5725.000	3.14	42.58	45.72	122.30	-76.58	AVG	
5	*	5747.000	53.63	42.66	96.29	122.30	-26.01	peak	
6		5750.200	45.15	42.67	87.82	122.30	-34.48	AVG	

Orthogonal Axis:	X
Test Mode:	UNII-3/TX N40 Mode 5755MHz

Horizontal

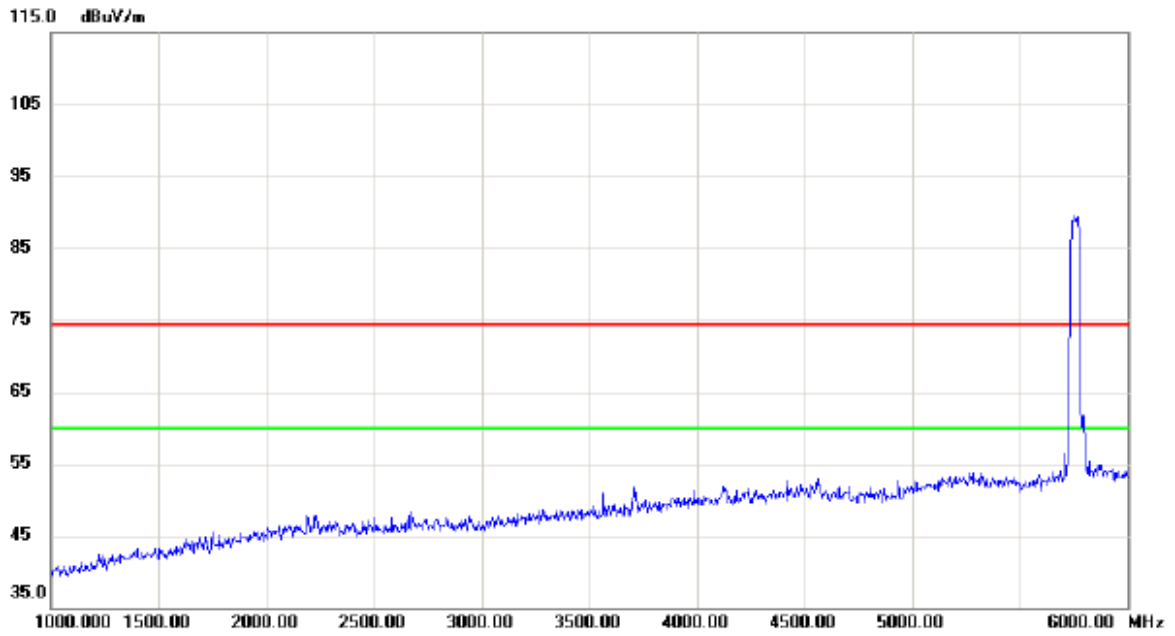

No.	Mk.	Freq.	Reading Level	Correct Factor	Measurement	Limit	Margin	Detector	Comment
		MHz	dBuV	dB	dBuV/m	dBuV/m	dB		

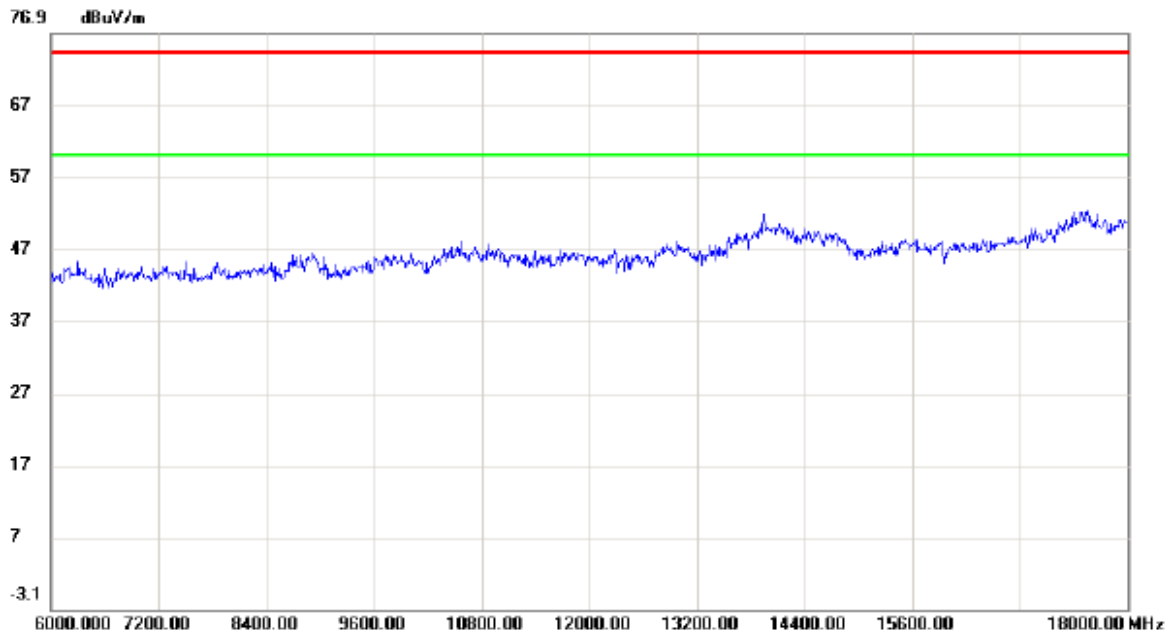

No.	Mk.	Freq.	Reading Level	Correct Factor	Measurement	Limit	Margin	Detector	Comment
		MHz	dBuV	dB	dBuV/m	dBuV/m	dB		

Orthogonal Axis:	X
Test Mode:	UNII-3/TX N40 Mode 5755MHz

Horizontal

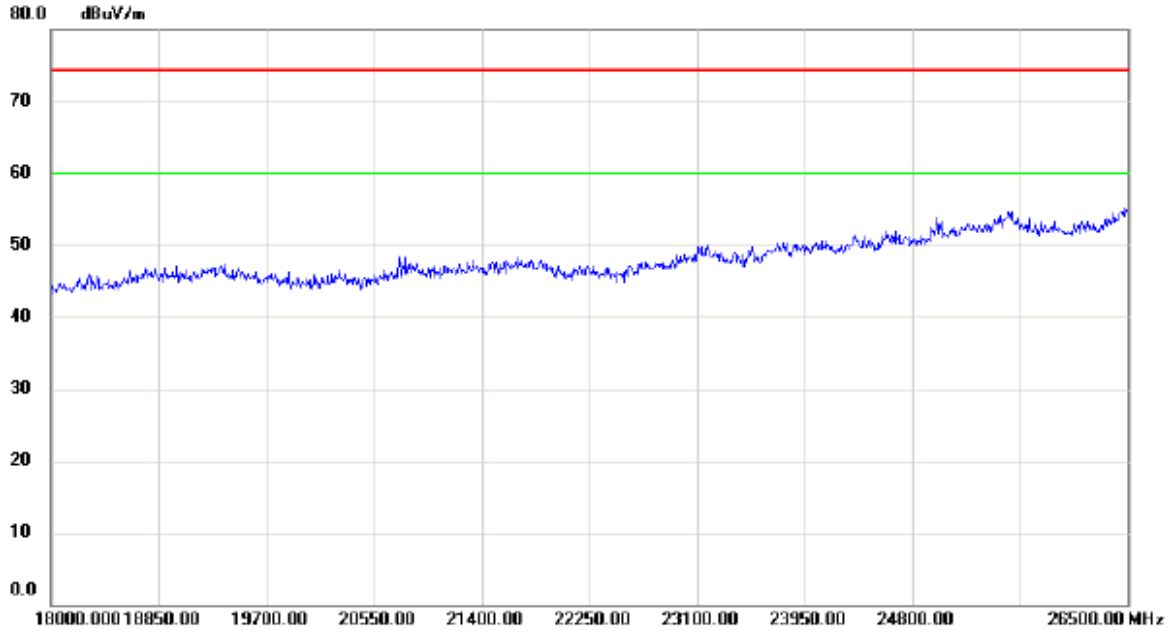

No.	Mk.	Freq.	Reading Level	Correct Factor	Measurement	Limit	Margin	Detector	Comment
		MHz	dBuV	dB	dBuV/m	dBuV/m	dB		

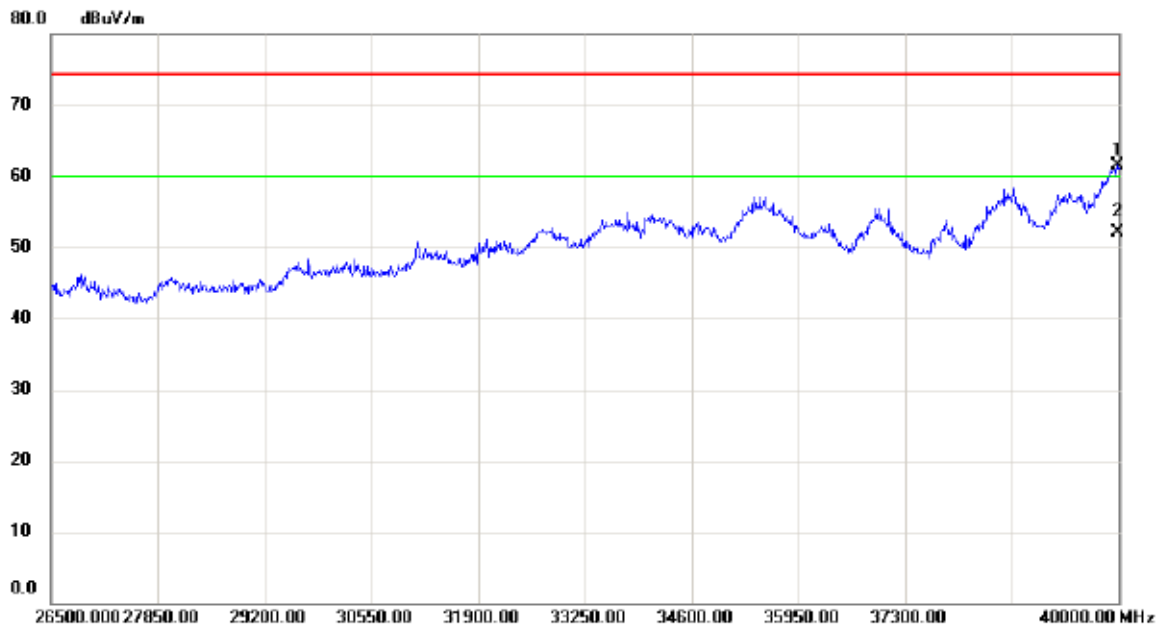

No.	Mk.	Freq.	Reading Level	Correct Factor	Measurement	Limit	Margin	Detector	Comment
		MHz	dBuV	dB	dBuV/m	dBuV/m	dB		
1		39986.50	45.57	15.86	61.43	74.30	-12.87	peak	
2	*	39986.04	36.25	15.86	52.11	60.00	-7.89	AVG	

Orthogonal Axis:	X
Test Mode:	UNII-3/TX N40 Mode 5795MHz

Vertical

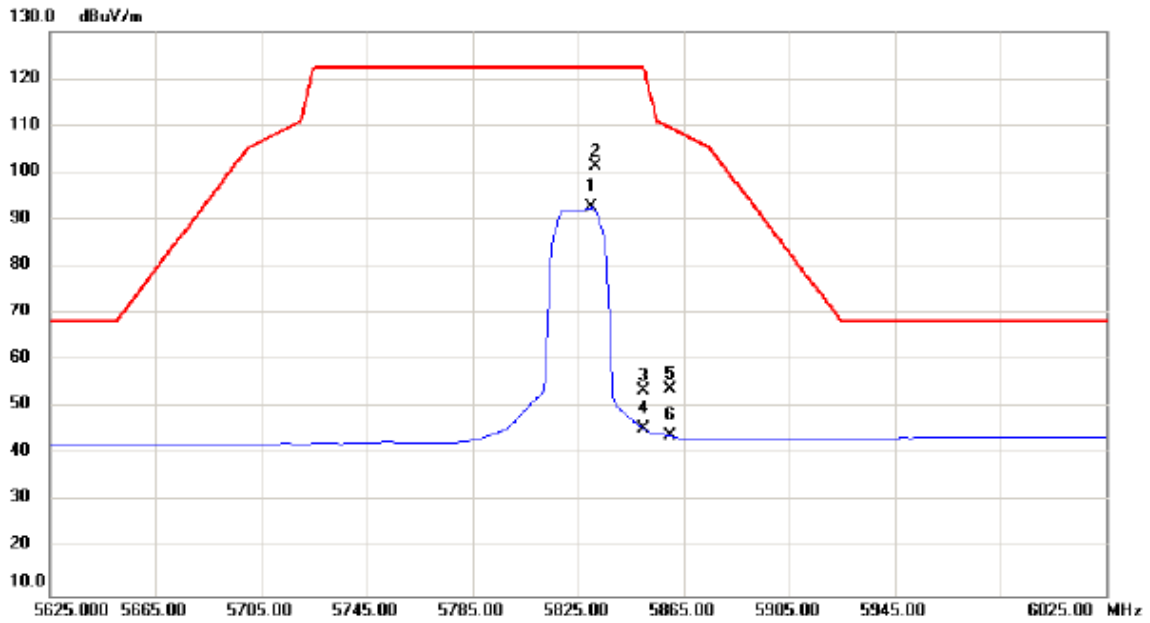

No.	Mk.	Freq.	Reading Level	Correct Factor	Measurement	Limit	Margin	Detector	Comment
		MHz	dBuV	dB	dBuV/m	dBuV/m	dB		
1		5830.200	49.56	42.95	92.51	122.30	-29.79	AVG	
2	*	5831.800	58.25	42.96	101.21	122.30	-21.09	peak	
3		5850.000	10.77	43.03	53.80	122.30	-68.50	peak	
4		5850.000	2.38	43.03	45.41	122.30	-76.89	AVG	
5		5860.000	11.00	43.06	54.06	109.50	-55.44	peak	
6		5860.000	0.92	43.06	43.98	109.50	-65.52	AVG	

Orthogonal Axis:	X
Test Mode:	UNII-3/TX N40 Mode 5795MHz

Vertical

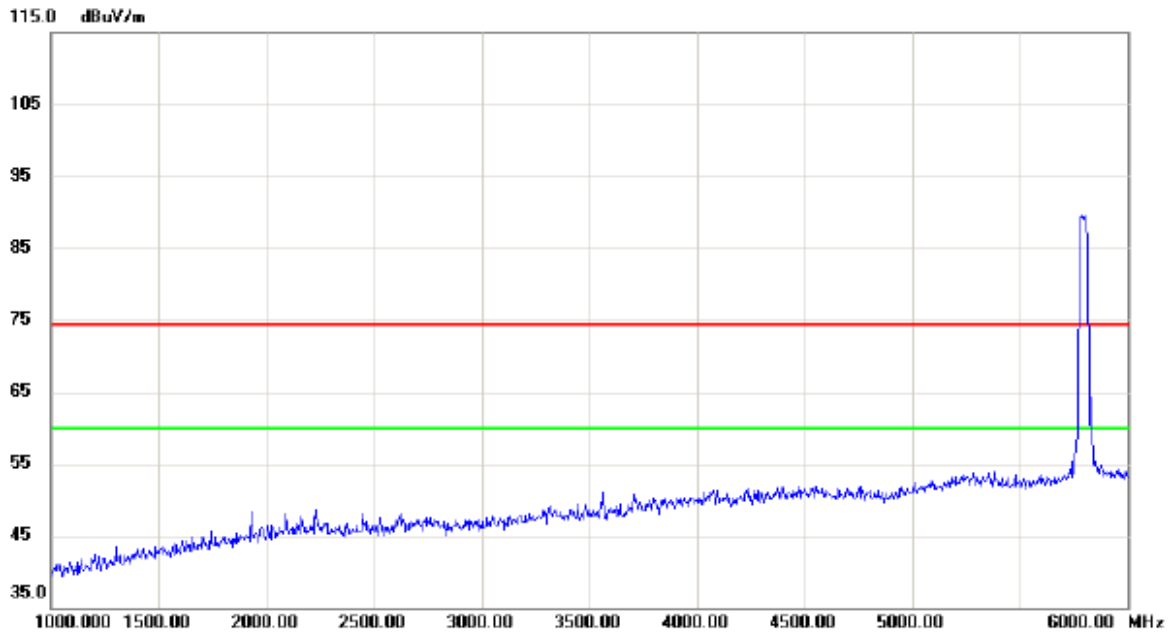

No.	Mk.	Freq.	Reading Level	Correct Factor	Measurement	Limit	Margin	Detector	Comment
		MHz	dBuV	dB	dBuV/m	dBuV/m	dB		

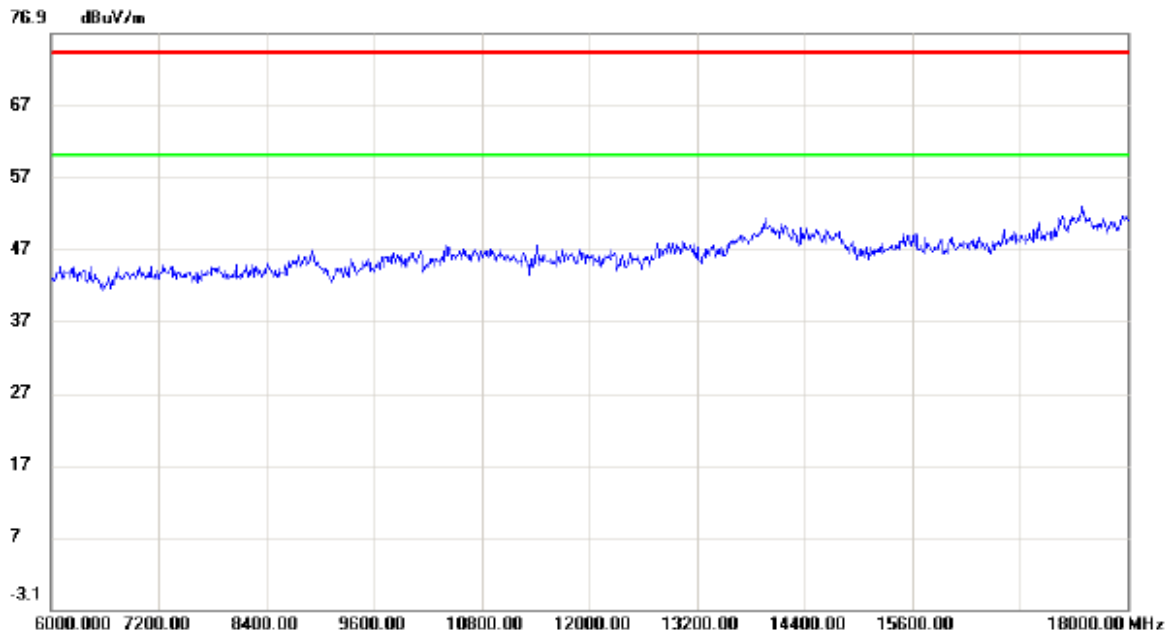

No.	Mk.	Freq.	Reading Level	Correct Factor	Measurement	Limit	Margin	Detector	Comment
		MHz	dBuV	dB	dBuV/m	dBuV/m	dB		

Orthogonal Axis:	X
Test Mode:	UNII-3/TX N40 Mode 5795MHz

Vertical

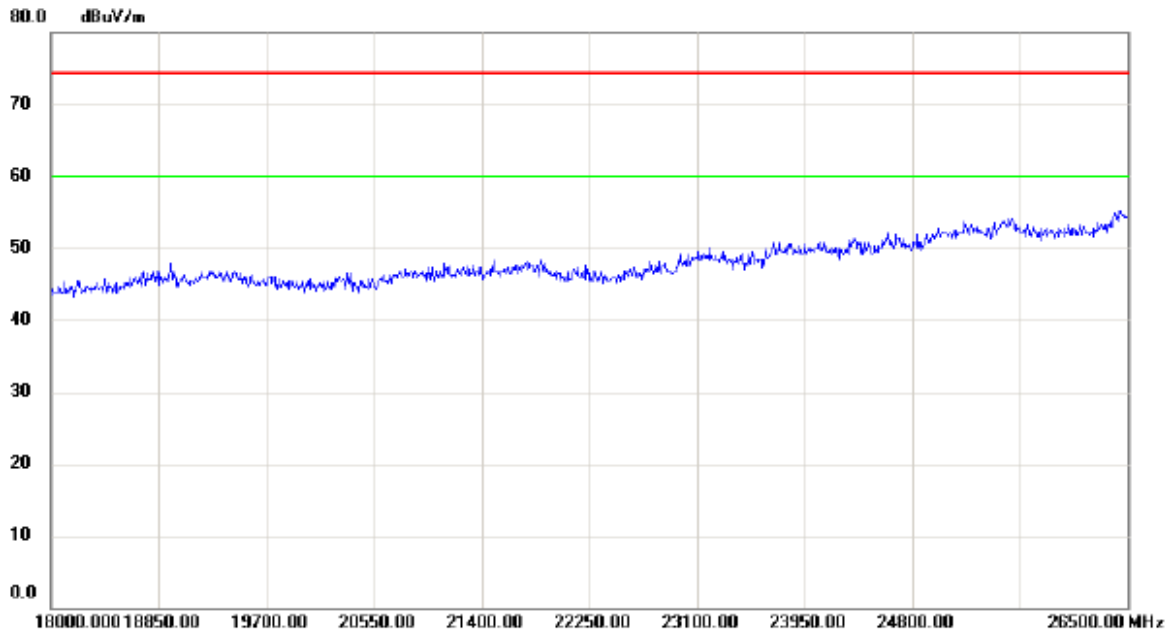

No.	Mk.	Freq.	Reading Level	Correct Factor	Measurement	Limit	Margin	Detector	Comment
		MHz	dBuV	dB	dBuV/m	dBuV/m	dB		

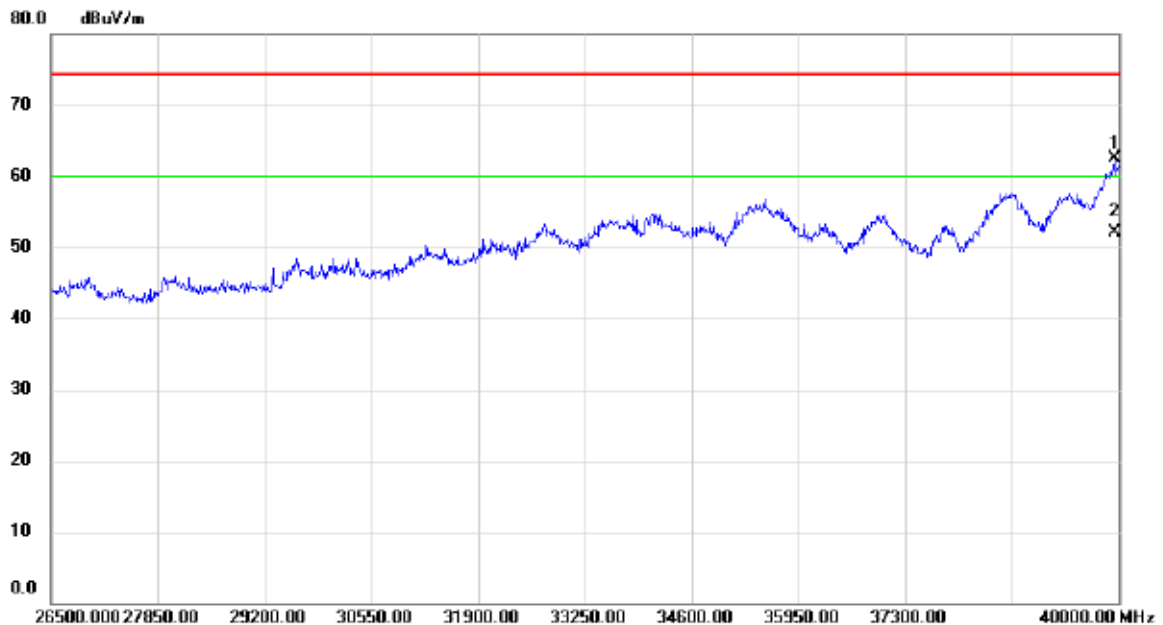

No.	Mk.	Freq.	Reading Level	Correct Factor	Measurement	Limit	Margin	Detector	Comment
		MHz	dBuV	dB	dBuV/m	dBuV/m	dB		
1		39946.00	46.64	15.81	62.45	74.30	-11.85	peak	
2	*	39946.00	36.34	15.81	52.15	60.00	-7.85	AVG	

Orthogonal Axis:	X
Test Mode:	UNII-3/TX N40 Mode 5795MHz

Horizontal

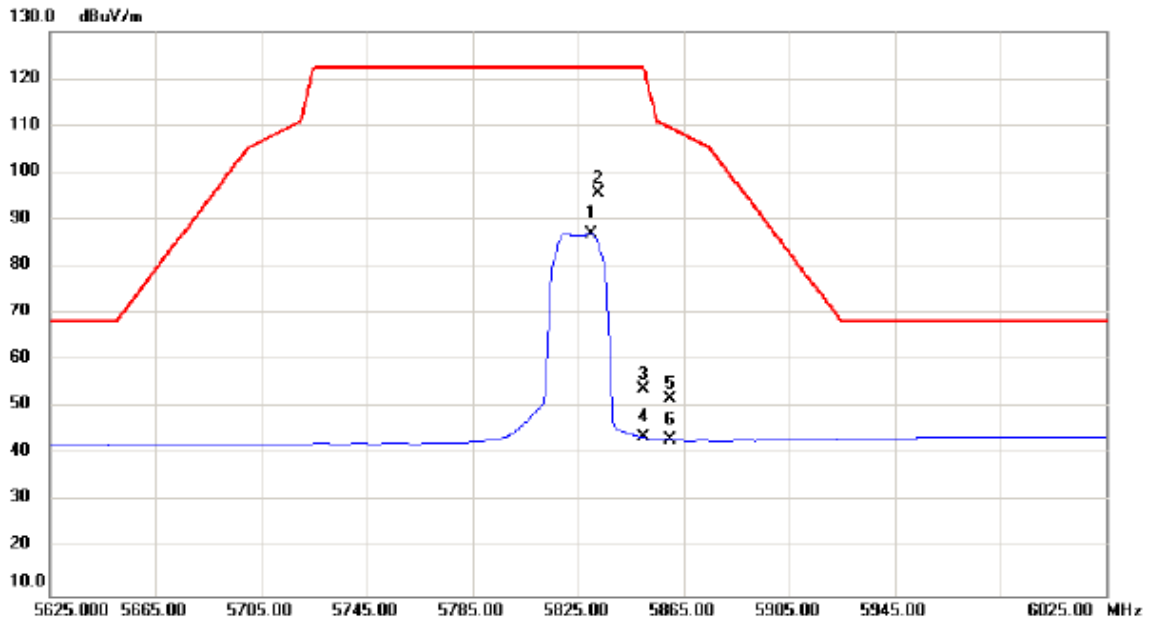

No.	Mk.	Freq.	Reading Level	Correct Factor	Measurement	Limit	Margin	Detector	Comment
		MHz	dBuV	dB	dBuV/m	dBuV/m	dB		
1		5830.200	44.02	42.95	86.97	122.30	-35.33	AVG	
2	*	5832.600	52.59	42.97	95.56	122.30	-26.74	peak	
3		5850.000	10.91	43.03	53.94	122.30	-68.36	peak	
4		5850.000	0.60	43.03	43.63	122.30	-78.67	AVG	
5		5860.000	8.76	43.06	51.82	109.50	-57.68	peak	
6		5860.000	0.21	43.06	43.27	109.50	-66.23	AVG	

Orthogonal Axis:	X
Test Mode:	UNII-3/TX N40 Mode 5795MHz

Horizontal

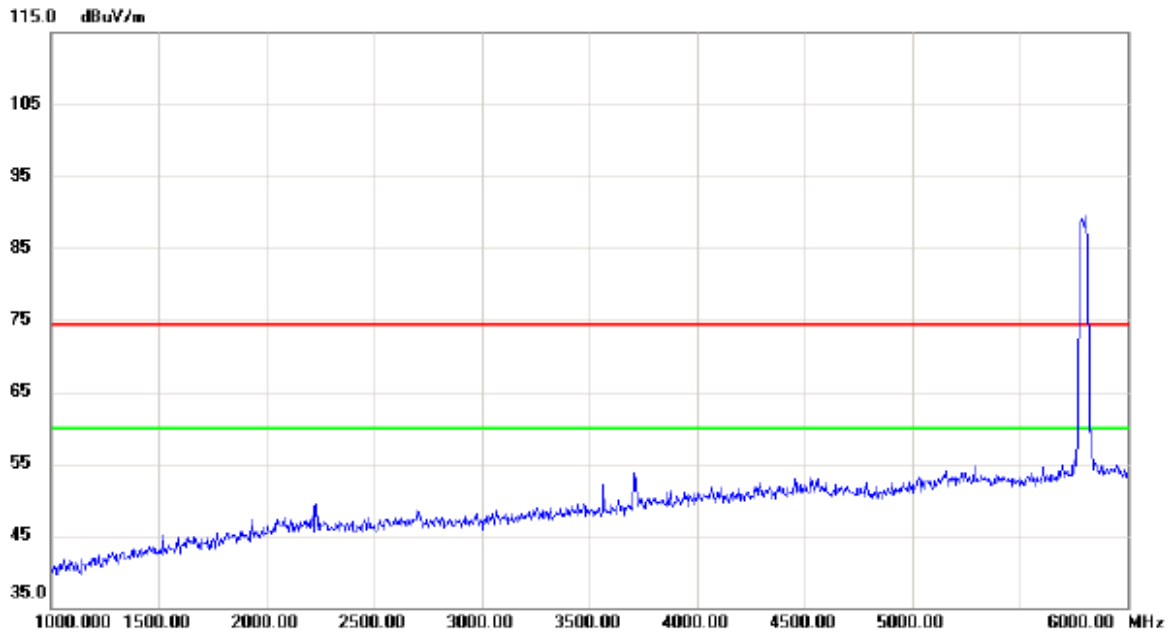

No.	Mk.	Freq.	Reading Level	Correct Factor	Measurement	Limit	Margin	Detector	Comment
		MHz	dBuV	dB	dBuV/m	dBuV/m	dB		

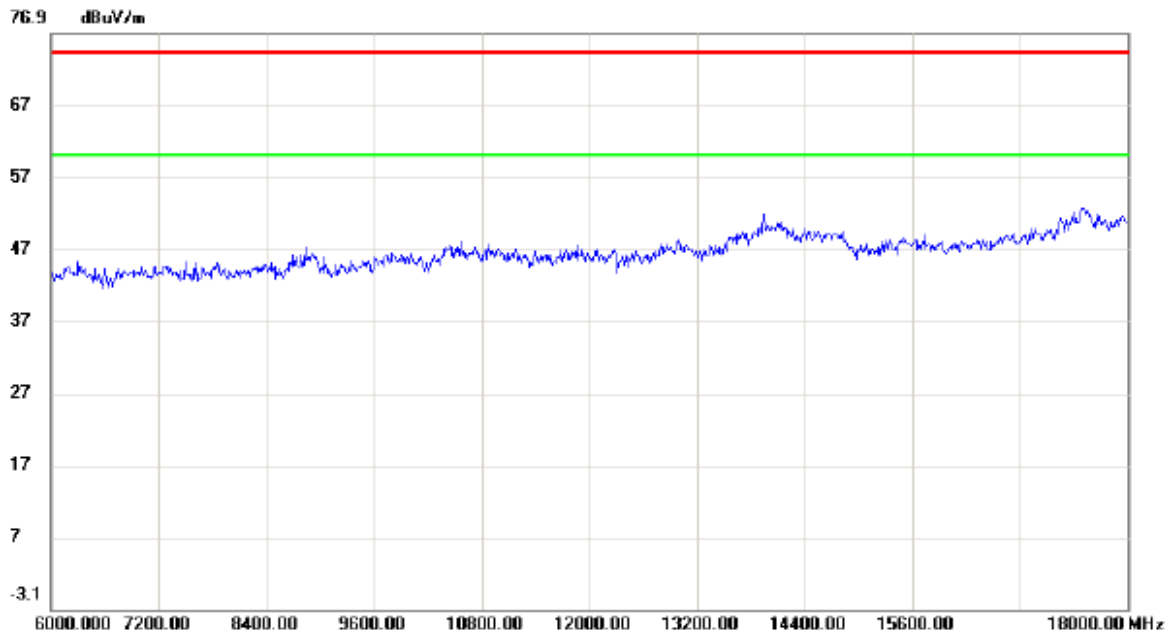

No.	Mk.	Freq.	Reading Level	Correct Factor	Measurement	Limit	Margin	Detector	Comment
		MHz	dBuV	dB	dBuV/m	dBuV/m	dB		

Orthogonal Axis:	X
Test Mode:	UNII-3/TX N40 Mode 5795MHz

Horizontal

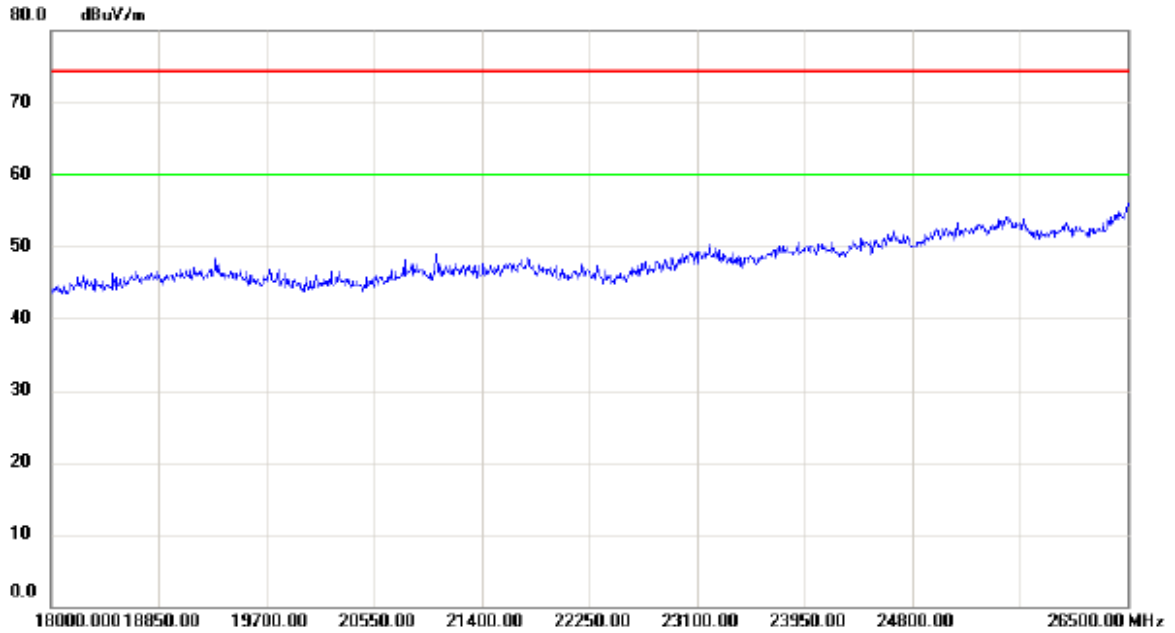

No.	Mk.	Freq.	Reading Level	Correct Factor	Measurement	Limit	Margin	Detector	Comment
		MHz	dBuV	dB	dBuV/m	dBuV/m	dB		

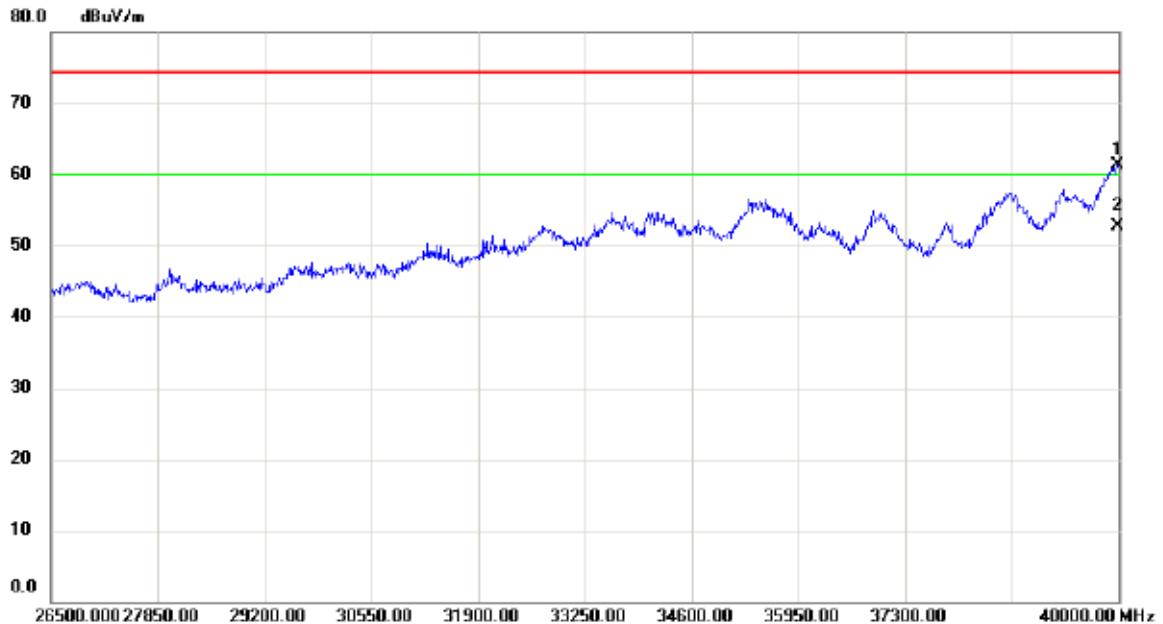

No.	Mk.	Freq.	Reading Level	Correct Factor	Measurement	Limit	Margin	Detector	Comment
		MHz	dBuV	dB	dBuV/m	dBuV/m	dB		
1		39986.50	45.38	15.86	61.24	74.30	-13.06	peak	
2	*	39986.37	36.85	15.86	52.71	60.00	-7.29	AVG	