

Report on the Intermodulation Testing

For

Gas Control Limited

on

Zeno Lite with Clarity

Report no. TRA-041253-47-02A

26 March 2019

RF915 4.0

Report Number: TRA-041253-47-02A
Issue: A

REPORT ON THE INTERMODULATION TESTING OF A
GAS CONTROL LIMITED
ZENO LITE WITH CLARITY
WITH RESPECT TO SPECIFICATIONS
47CFR PARTS 15, 22, 27, 24
INTERMODULATION EMISSIONS INVESTIGATION

TEST DATE: 2019/03/11 to 2019/03/15

Written by:

Steven Garwell
Radio Test Engineer

Approved by:

John Charters
Department Manager- Radio

Date: 26 March 2019

Disclaimers:

[1] THIS DOCUMENT MAY BE REPRODUCED ONLY IN ITS ENTIRETY AND WITHOUT CHANGE
[2] THE RESULTS CONTAINED IN THIS DOCUMENT RELATE ONLY TO THE ITEM(S) TESTED

RF915 4.0

1 Revision Record

<i>Issue Number</i>	<i>Issue Date</i>	<i>Revision History</i>
A	26 March 2019	Original

2 Summary

TEST REPORT NUMBER: TRA-041253-47-02A

WORKS ORDER NUMBER: TRA-041253-03

PURPOSE OF TEST: USA: Testing of radio frequency equipment per the relevant authorization procedure of chapter 47 of CFR (code of federal regulations) Part 2, subpart J.

TEST SPECIFICATION(S): Intermodulation emissions investigation using 47CFR Parts 15, 22, 27, 24

EQUIPMENT UNDER TEST (EUT): Zeno Lite with Clarity

EUT SERIAL NUMBER: ZL101416

MANUFACTURER/AGENT: Gas Control Limited

ADDRESS: 100 Empress Park
Penny Lane
Haydock
St Helens
WA11 9DB
United Kingdom

CLIENT CONTACT: Will Turner
☎ 01942 292962
✉ will.turner@gcegroup.com

ORDER NUMBER: 45-027-022

TEST DATE: 2019/03/11 to 2019/03/15

TESTED BY: Steven Garwell / Daniel Moncayola
Element

2.1 Test Summary

<i>Test Method and Description</i>	<i>Requirement Clause</i>	<i>Applicable to this equipment</i>	<i>Result / Note</i>
	<i>47CFR</i>		
Intermodulation spurious emissions	Parts 15, 22, 27, 24	☒	<i>Pass</i>

Notes:

The results contained in this report relate only to the items tested, in the condition at time of test, and were obtained in the period between the date of initial receipt of samples and the date of issue of the report.

The apparatus was set up and exercised using the configurations, modes of operation and arrangements defined in this report only. Any modifications made are identified in Section 8 of this report.

Particular operating modes, apparatus monitoring methods and performance criteria required by the standards tested to have been performed except where identified in Section 5.2 of this test report (Deviations from Test Standards).

3 Contents

1	Revision Record	3
2	Summary	4
2.1	Test Summary	5
3	Contents	6
4	Introduction	7
5	Glossary of Terms	8
6	Equipment Under Test.....	9
6.1	EUT Identification	9
6.2	System Equipment.....	9
6.3	EUT Mode of Operation.....	9
6.3.1	Transmission	9
6.4	EUT Description	9
7	Modifications.....	9
8	EUT Test Setup	10
8.1	Block Diagram	10
8.2	General Set-up Photograph.....	11
9	General Technical Parameters.....	12
9.1	Normal Conditions	12
10	Radiated emissions, intermodulation products	13
10.1	Definitions	13
10.2	Test Parameters	13
10.3	Test Limits	14
10.4	Test Method.....	15
10.5	Test Set-up Photograph.....	16
10.6	Test Equipment	16
10.7	Results.....	17
11	Measurement Uncertainty.....	37

4 Introduction

This report TRA-041253-47-02A presents the results of the Radio testing on a Gas Control Limited, Zeno Lite with Clarity.

The Zeno Lite with Clarity contains Pre-approved Radio modules that are able to operate simultaneously.

The testing was carried out for Gas Control Limited by Element, at the address detailed below.

<input type="checkbox"/>	Element Hull Unit E South Orbital Trading Park Hedon Road Hull HU9 1NJ UK	<input checked="" type="checkbox"/>	Element Skelmersdale Unit 1 Pendle Place Skelmersdale West Lancashire WN8 9PN UK
--------------------------	---------------------------------------------------------------------------------------------	-------------------------------------	----------------------------------------------------------------------------------------------------

This report details the configuration of the equipment, the test methods used and any relevant modifications where appropriate.

All test and measurement equipment under the control of the laboratory and requiring calibration is subject to an established programme and procedures to control and maintain measurement standards. The quality management system meets the principles of ISO 9001, and has quality control procedures for monitoring the validity of tests undertaken. Records and sufficient detail are retained to establish an audit trail of calibration records relating to its test results for a defined period. Under control of the established calibration programme, key quantities or values of the test & measurement instrumentation are within specification and comply with the relevant traceable internationally recognised and appropriate standard specifications, which are UKAS calibrated as such where these properties have a significant effect on results. Participation in inter-laboratory comparisons and proficiency testing ensures satisfactory correlation of results conform to Elements own procedures, as well as statistical techniques for analysis of test data providing the appropriate confidence in measurements.

Throughout this report EUT denotes equipment under test.

FCC Site Listing:

Element is accredited for the above sites under the US-EU MRA, Designation number UK0009.

The test site requirements of ANSI C63.4-2014 are met up to 1GHz.

The test site SVSWR requirements of CISPR 16-1-4:2010 are met over the frequency range 1 GHz to 18 GHz.

5 Glossary of Terms

§	denotes a section reference from the standard, not this document
AC	Alternating Current
ANSI	American National Standards Institute
BW	bandwidth
C	Celsius
CFR	Code of Federal Regulations
CW	Continuous Wave
dB	decibel
dBm	dB relative to 1 milliwatt
DC	Direct Current
DSSS	Direct Sequence Spread Spectrum
EIRP	Equivalent Isotropically Radiated Power
ERP	Effective Radiated Power
EUT	Equipment Under Test
FCC	Federal Communications Commission
FHSS	Frequency Hopping Spread Spectrum
Hz	hertz
IC	Industry Canada
ITU	International Telecommunication Union
LBT	Listen Before Talk
m	metre
max	maximum
MIMO	Multiple Input and Multiple Output
min	minimum
MRA	Mutual Recognition Agreement
N/A	Not Applicable
PCB	Printed Circuit Board
PDF	Portable Document Format
Pt-mpt	Point-to-multipoint
Pt-pt	Point-to-point
RF	Radio Frequency
RH	Relative Humidity
RMS	Root Mean Square
Rx	receiver
s	second
SVSWR	Site Voltage Standing Wave Ratio
Tx	transmitter
UKAS	United Kingdom Accreditation Service
V	volt
W	watt
Ω	ohm

6 Equipment Under Test

6.1 EUT Identification

- Name: Zeno Lite with Clarity
- Serial Number: ZL101416
- Model Number: RS-00600C
- Software Revision: V 1.360
- Build Level / Revision Number: Pre-Production

6.2 System Equipment

Equipment listed below forms part of the overall test setup and is required for equipment functionality and/or monitoring during testing. The compliance levels achieved in this report relate only to the EUT and not items given in the following list.

1: CMW 500 Wideband Communications Tester – Serial Number: 112969

2: Laptop

6.3 EUT Mode of Operation

6.3.1 Transmission

The mode of operation for transmitter tests was as follows:

Radios were set to transmit permanently in various combinations, the spectrum was checked to determine if any intermodulation products were generated due to multiple radios operating simultaneously. The worst case emission plots are shown in this document.

EUT was operated with worst case modes of operation for each radio device.

6.4 EUT Description

The EUT is a portable oxygen concentrator for patients requiring supplementary oxygen. The device has multiple wireless connections. This report covers intermodulations produced by the simultaneous transitions between the LTE module and the Bluetooth Low

- BTLE Radio Module: FCC ID: QOQBGM12LMA
- LTE Radio Module: FCC ID: QIPPLS62-W

7 Modifications

No modifications were performed during this assessment.

8 EUT Test Setup

8.1 Block Diagram

The following diagram shows basic EUT interconnections with cable type and cable lengths identified:

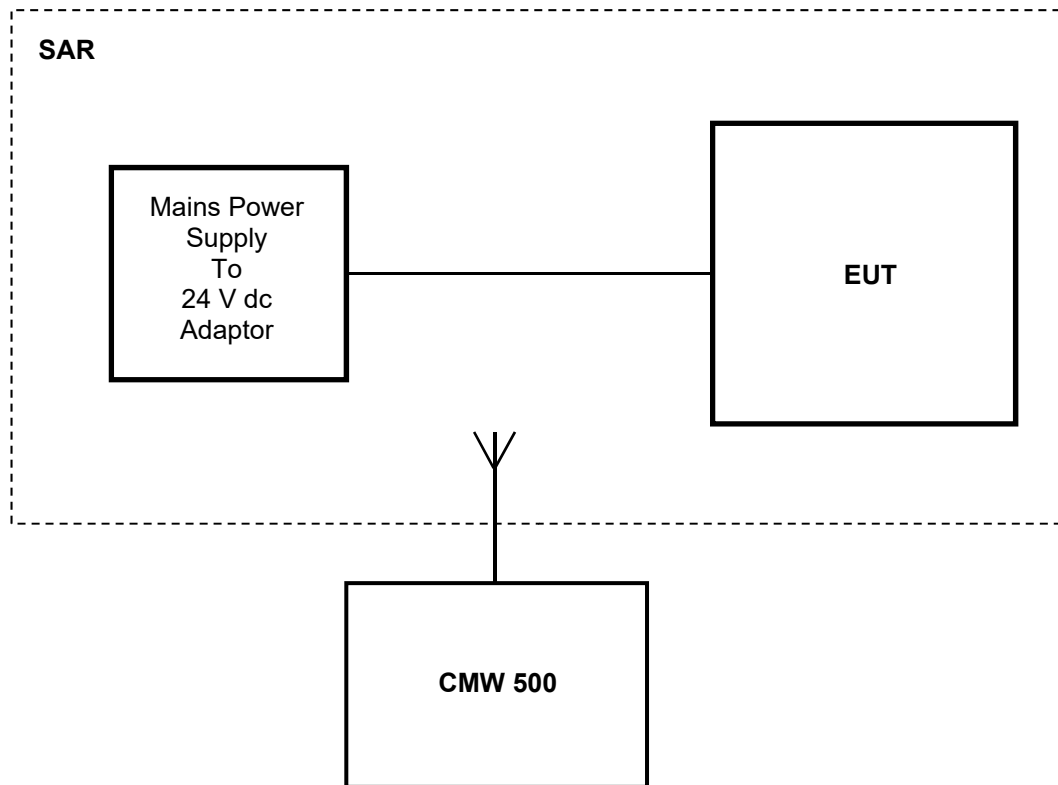

8.2 General Set-up Photograph

The following photographs shows basic EUT set-up:

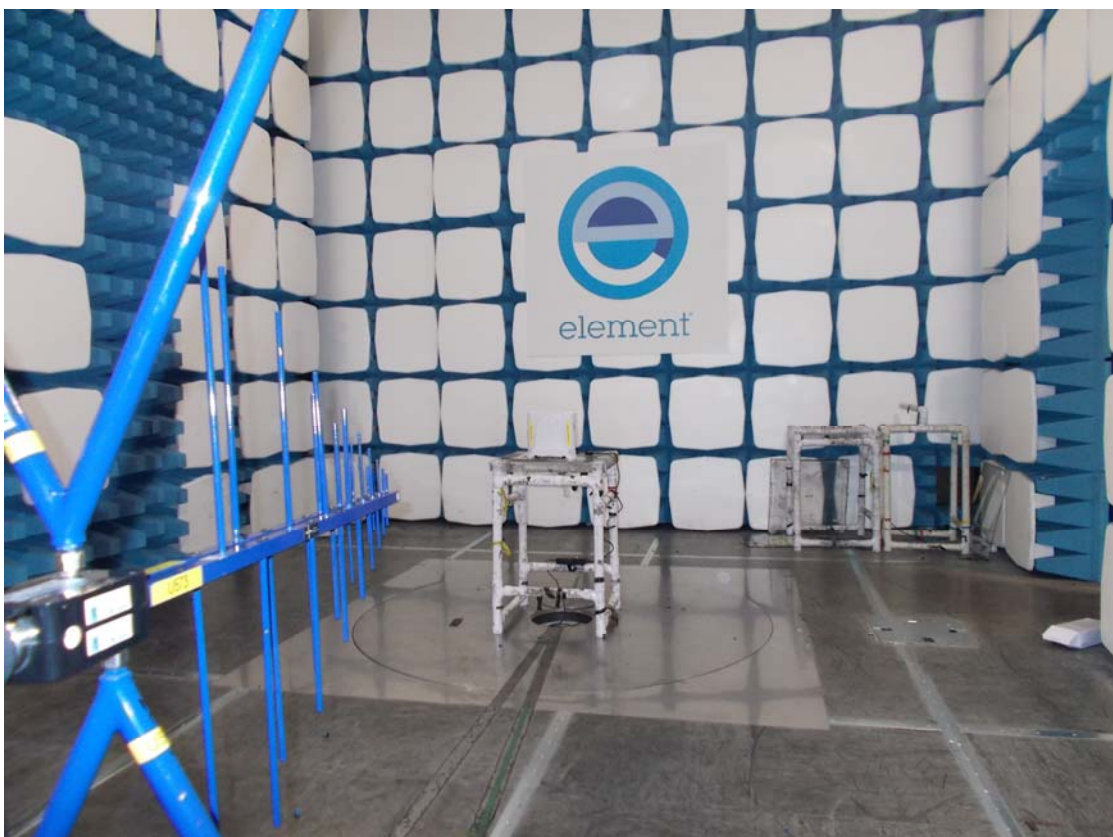
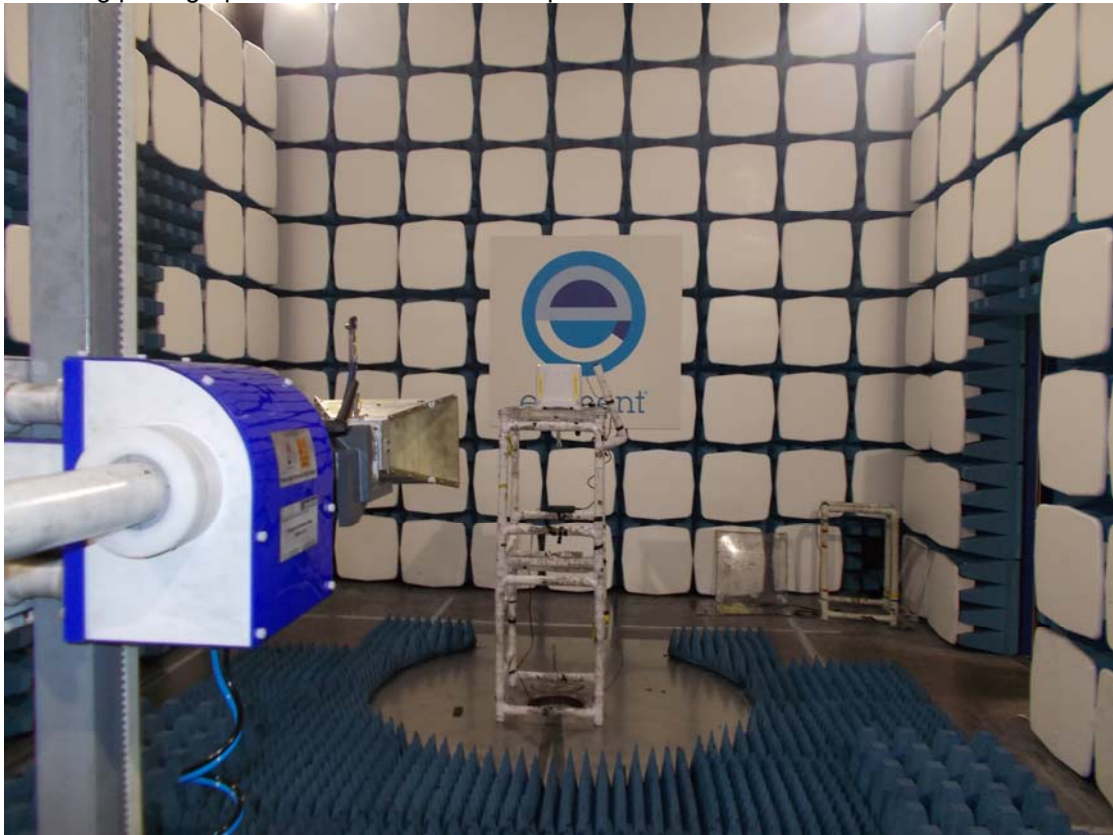

9 General Technical Parameters

9.1 Normal Conditions

The Zeno Lite with Clarity was tested under the normal environmental conditions of the test laboratory, except where otherwise stated. The normal power source applied was mains via a 24 V dc adaptor.

10 Radiated emissions, intermodulation products

10.1 Definitions

Spurious emissions

Emissions on a frequency or frequencies, which are outside the necessary bandwidth and the level of which may be reduced without affecting the corresponding transmission of information. Spurious emissions include harmonic emissions, parasitic emissions, intermodulation products and frequency conversion products, but exclude out-of-band emissions.

Intermodulation products

Emissions of two or more electromagnetic waves transmitted simultaneously through a nonlinear electronic system.

10.2 Test Parameters

Test Location:	Element Skelmersdale
Test Chamber:	Radio chamber
Test Standard and Clause:	ANSI C63.10-2013, Clause 6.5 and 6.6
Deviations From Standard:	None
Measurement BW:	30 MHz to 1 GHz: 120 kHz Above 1 GHz: 1 MHz
Measurement Detector:	Up to 1 GHz: quasi-peak Above 1 GHz: RMS average and Peak

Environmental Conditions (Normal Environment)

Temperature: 25 °C	+15 °C to +35 °C (as declared)
Humidity: 34% RH	20 % RH to 75 % RH (as declared)
Supply: 24 V dc	

10.3 Test Limits

Part 15

Unwanted emissions that fall within the restricted frequency bands shall comply with the limits specified:

General Field Strength Limits for License-Exempt Transmitters at Frequencies above 30 MHz

<i>Frequency (MHz)</i>	<i>Field Strength ($\mu\text{V/m}$ at 3 m)</i>
30 to 88	100
88 to 216	150
216 to 960	200
Above 960	500

Part 22 & Part 24

At least $43 + 10 \log P$ dB

$$(10 \log P_{\text{watts}}) - (43 + 10 \log (P_{\text{watts}} * 1000)) = \text{LIMIT} = -13 \text{ dBm}$$

10.4 Test Method

With the EUT setup as per section 9 of this report and connected as per Figure i, the emissions from the EUT were measured on a spectrum analyzer / EMI receiver.

Radiated electromagnetic emissions from the EUT are checked first by preview scans. Preview scans for all spectrum and modulation characteristics are checked, using a peak detector and where applicable worst-case determined for function, operation, orientation, etc. for both vertical and horizontal polarisations. Pre-scan plots are shown with a peak detector and 100 kHz RBW.

If the EUT connects to auxiliary equipment and is table or floor standing, the configurations prescribed in ANSI C63.10 are followed. Alternatively, a layout closest to normal use (as declared by the provider) is employed, (see EUT setup photographs for more detail).

Emissions between 30 MHz and 1 GHz are measured using calibrated broadband antennas. Emissions above 1 GHz are characterized using standard gain horn antennas. Pre-amplifiers and filters are used where required. Care is taken to ensure that test receiver resolution bandwidth, video bandwidth and detector type(s) meet the regulatory requirements.

For both horizontal and vertical polarizations, the EUT is then rotated through 360 degrees in azimuth until the highest emission is detected. At the previously determined azimuth the test antenna is raised and lowered from 1 to 4 m in height until a maximum emission level is detected, this maximum value is recorded.

Power values measured on the test receiver / analyzer are converted to field strength, FS, in dB μ V/m at the regulatory distance, using:

$$FS = PR + CL + AF - PA + DC - CF$$

Where,

PR is the power recorded on the receiver / spectrum analyzer in dB μ V;

CL is the cable loss in dB;

AF is the test antenna factor in dB/m;

PA is the pre-amplifier gain in dB (where used);

DC is the duty correction factor in dB (where used, e.g. harmonics of pulsed fundamental);

CF is the distance factor in dB (where measurement distance different to limit distance);

This field strength value is then compared with the regulatory limit.

Figure i Test Setup

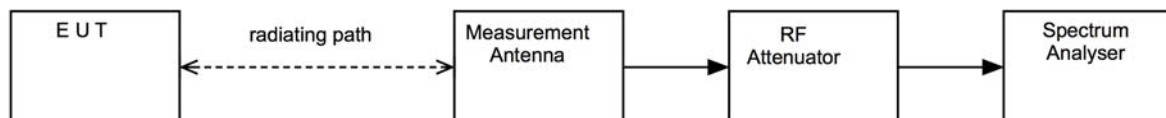

10.5 Test Set-up Photograph

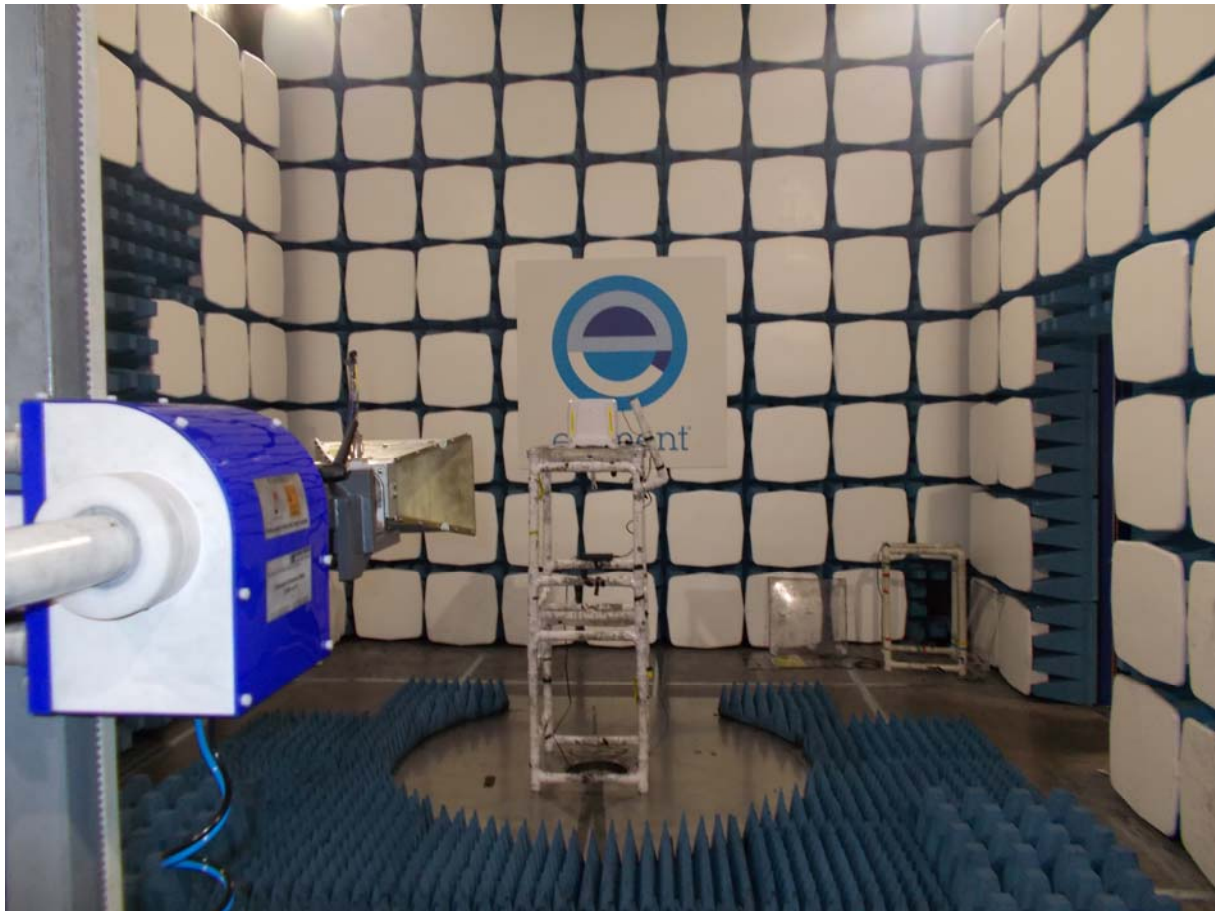

10.6 Test Equipment

<i>Equipment Description</i>	<i>Manufacturer</i>	<i>Equipment Type</i>	<i>Element No</i>	<i>Due For Calibration</i>
Receiver	R&S	ESVS10	L317	2019-03-22
Bilog	Chase	CBL611/A	U573	2019-08-02
Pre Amp	Agilent	8449B	L572	2019-10-12
1-18GHz Horn	EMCO	3115	L139	2019-09-25
Spectrum Analyser	R&S	FSU26	U405	2019-09-21

10.7 Results

Bottom Channel LTE Band II + Bottom Channel BLE

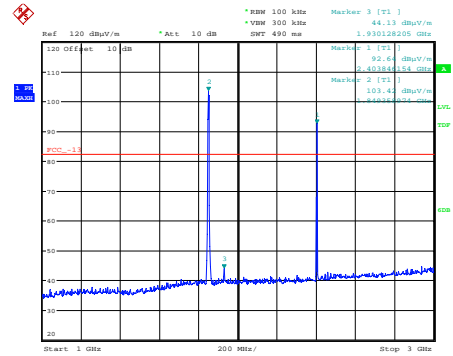
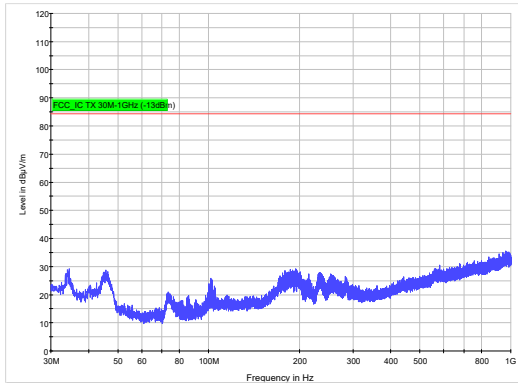

Date: 14.MAR.2019 15:47:09

30 MHz to 1 GHz

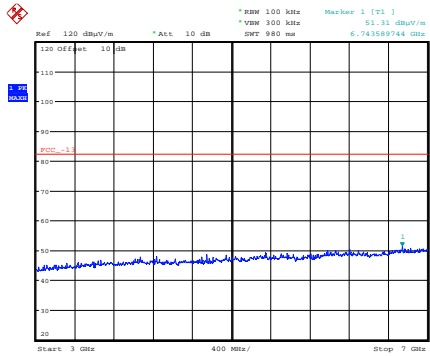

Date: 14.MAR.2019 15:46:11

1 GHz to 3 GHz

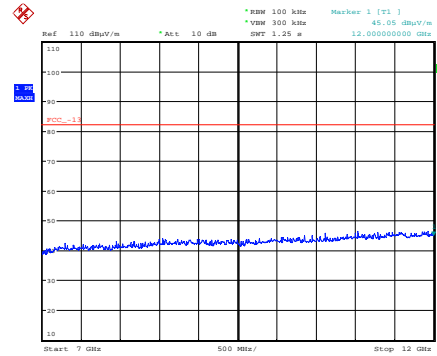

Date: 14.MAR.2019 15:25:23

3 GHz to 7 GHz

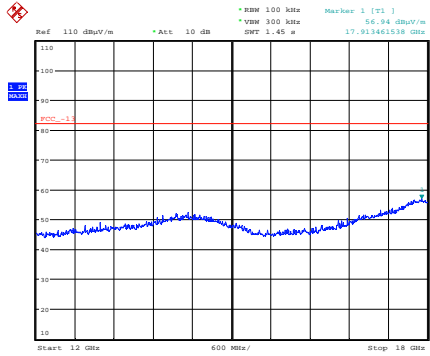

Date: 14.MAR.2019 15:24:17

7 GHz to 12 GHz

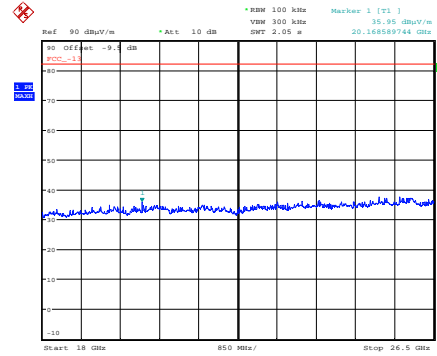

Date: 15.MAR.2019 07:47:20

12 GHz to 18 GHz

18 GHz to 26.5 GHz

All emissions on graphs are related to either the cellular operation, Bluetooth LE operation and are not intermodulation products.

Top Channel LTE Band II + Bottom Channel BLE

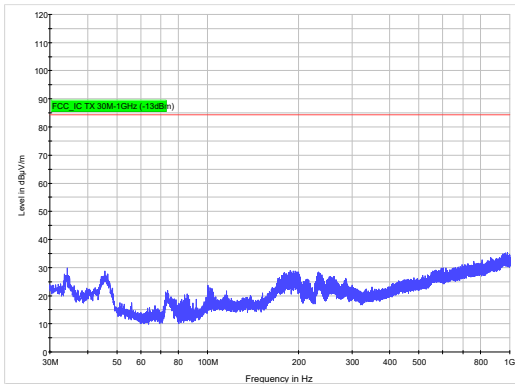

30 MHz to 1 GHz

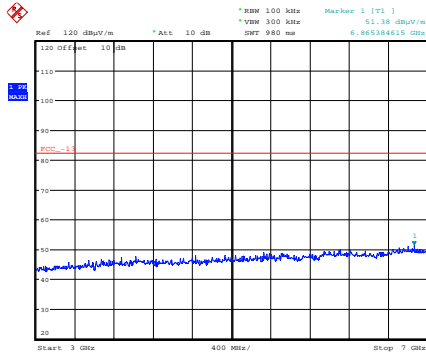

Date: 14.MAR.2019 15:38:57

3 GHz to 7 GHz

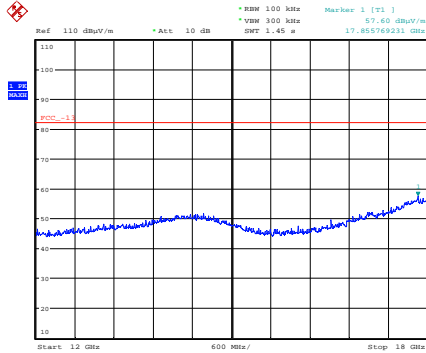

Date: 14.MAR.2019 15:19:00

12 GHz to 18 GHz

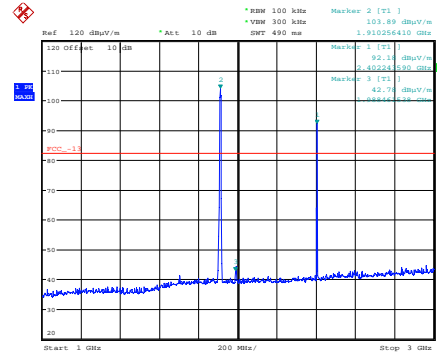

Date: 14.MAR.2019 15:37:37

1 GHz to 3 GHz

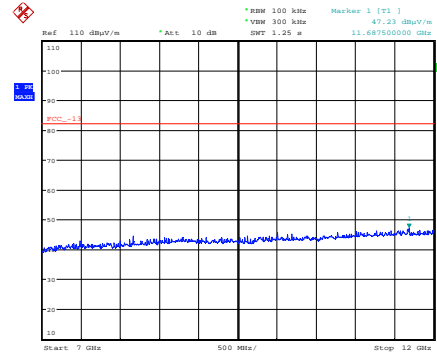

Date: 14.MAR.2019 15:18:07

7 GHz to 12 GHz

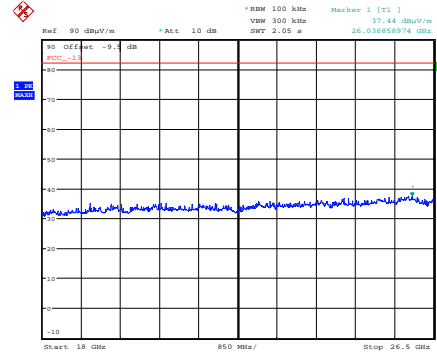

Date: 15.MAR.2019 07:48:25

18 GHz to 26.5 GHz

All emissions on graphs are related to either the cellular operation, Bluetooth LE operation and are not intermodulation products.

Bottom Channel LTE Band II + Top Channel BLE

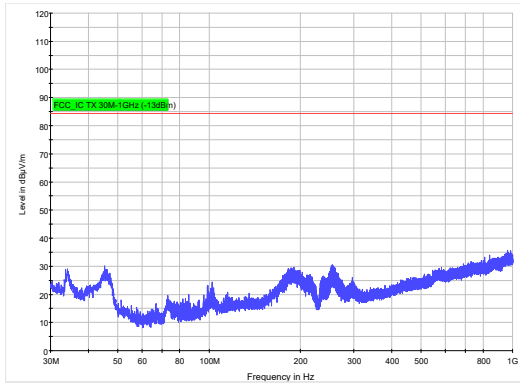

30 MHz to 1 GHz

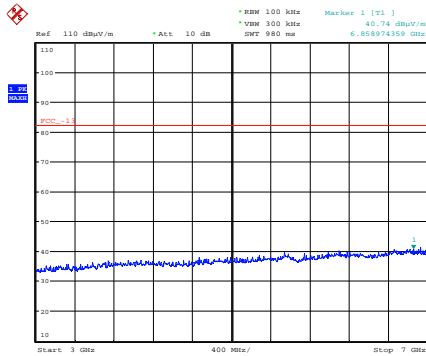

Date: 14.MAR.2019 10:43:39

3 GHz to 7 GHz

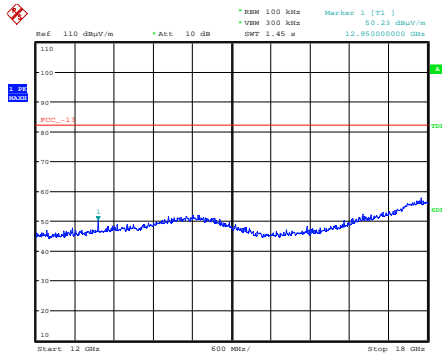

Date: 14.MAR.2019 10:59:35

12 GHz to 18 GHz

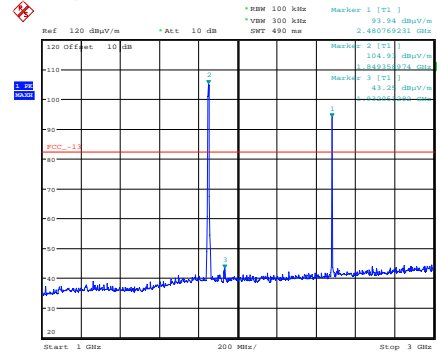

Date: 14.MAR.2019 10:53:01

1 GHz to 3 GHz

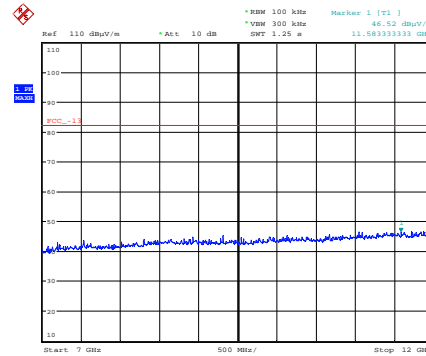

Date: 14.MAR.2019 10:56:32

7 GHz to 12 GHz

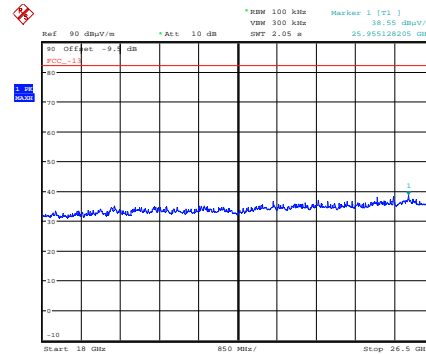

Date: 15.MAR.2019 07:13:16

18 GHz to 26.5 GHz

All emissions on graphs are related to either the cellular operation, Bluetooth LE operation and are not intermodulation products.

Top Channel LTE Band II + Top Channel BLE

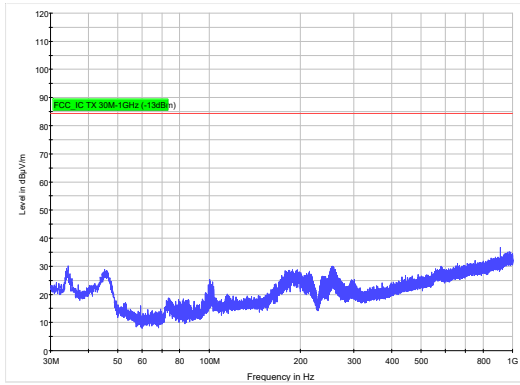

30 MHz to 1 GHz

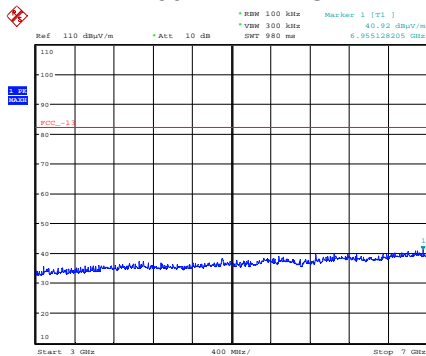

Date: 14.MAR.2019 10:46:36

3 GHz to 7 GHz

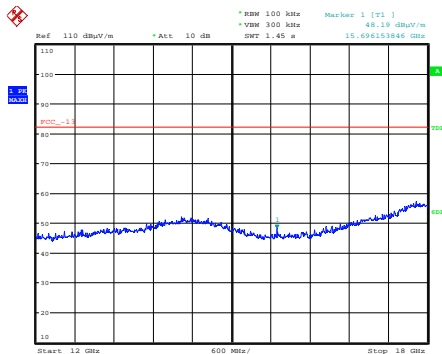

Date: 14.MAR.2019 11:00:38

12 GHz to 18 GHz

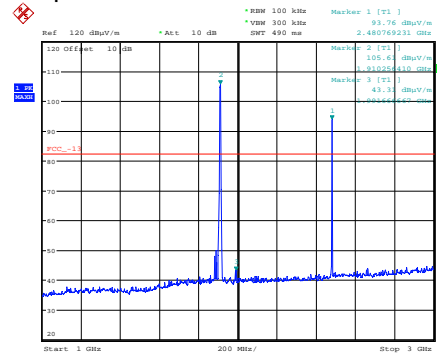

Date: 14.MAR.2019 10:50:02

1 GHz to 3 GHz

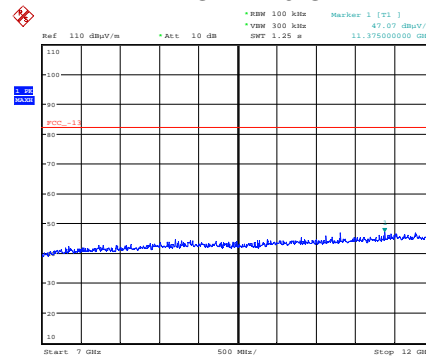

Date: 14.MAR.2019 11:03:39

7 GHz to 12 GHz

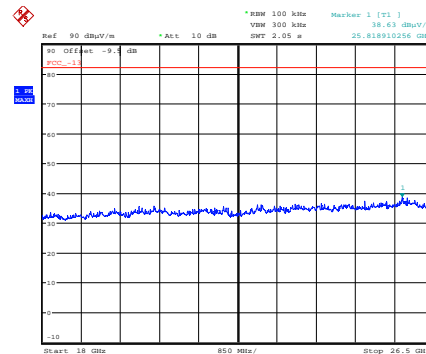

Date: 15.MAR.2019 07:14:26

18 GHz to 26.5 GHz

All emissions on graphs are related to either the cellular operation, Bluetooth LE operation and are not intermodulation products.

Bottom Channel LTE Band IV + Bottom Channel BLE

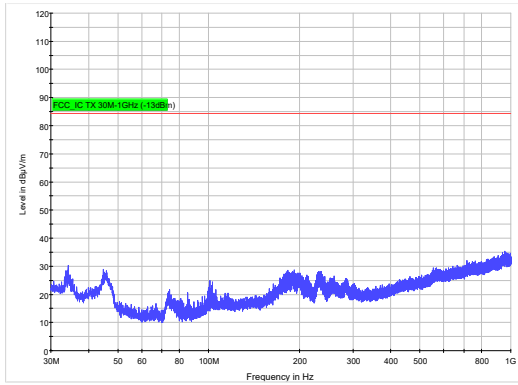

30 MHz to 1 GHz

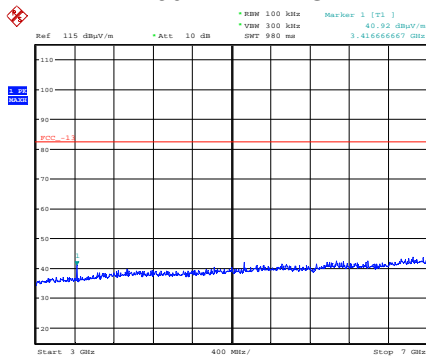

Date: 14.MAR.2019 15:40:25

3 GHz to 7 GHz

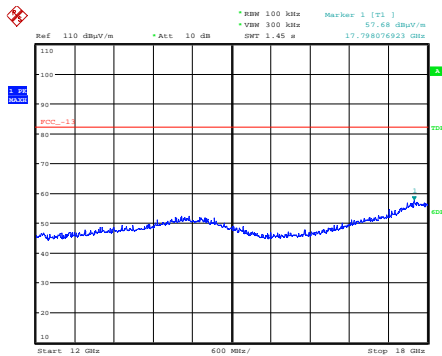

Date: 14.MAR.2019 15:11:26

12 GHz to 18 GHz

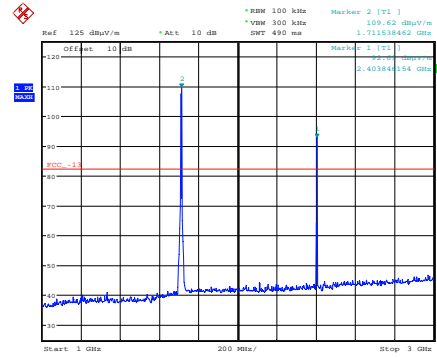

Date: 14.MAR.2019 15:49:40

1 GHz to 3 GHz

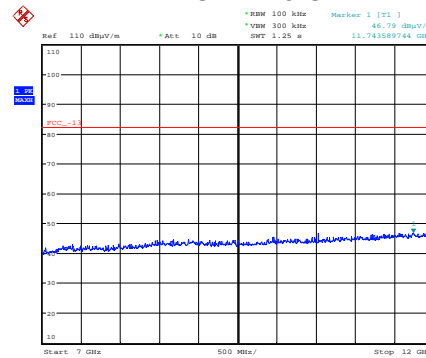

Date: 14.MAR.2019 15:14:51

7 GHz to 12 GHz

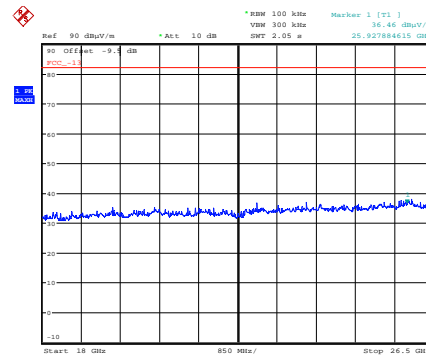

Date: 15.MAR.2019 07:54:14

18 GHz to 26.5 GHz

All emissions on graphs are related to either the cellular operation, Bluetooth LE operation and are not intermodulation products.

Top Channel LTE Band IV + Bottom Channel BLE

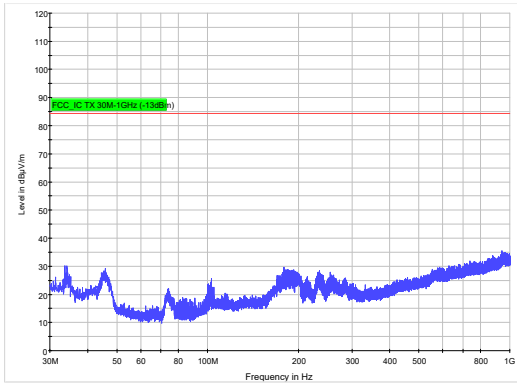

30 MHz to 1 GHz

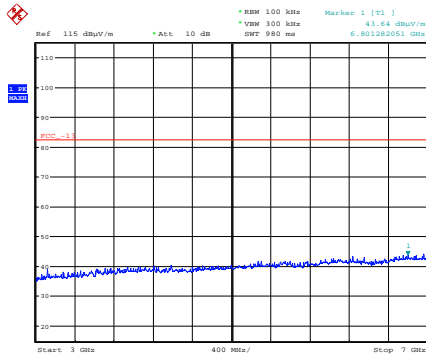

Date: 14.MAR.2019 15:36:50

3 GHz to 7 GHz

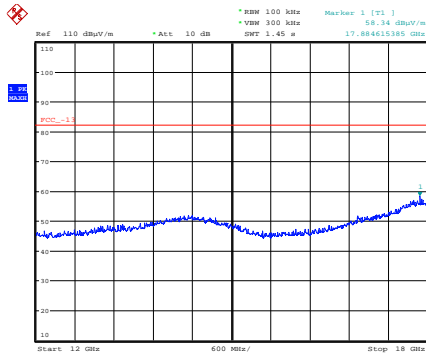

Date: 14.MAR.2019 15:04:39

12 GHz to 18 GHz

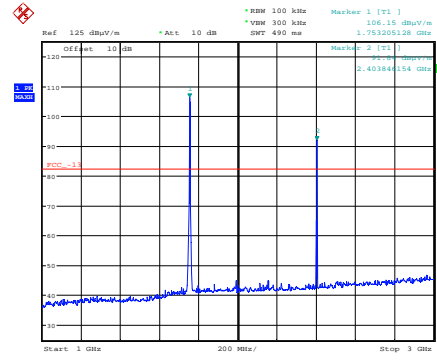

Date: 14.MAR.2019 15:55:22

1 GHz to 3 GHz

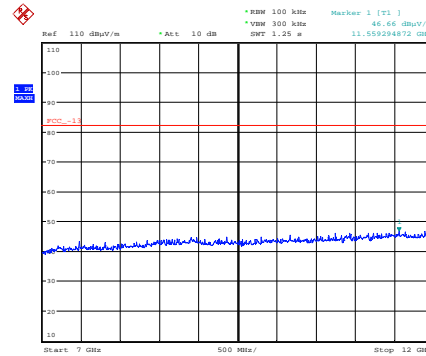

Date: 14.MAR.2019 15:03:13

7 GHz to 12 GHz

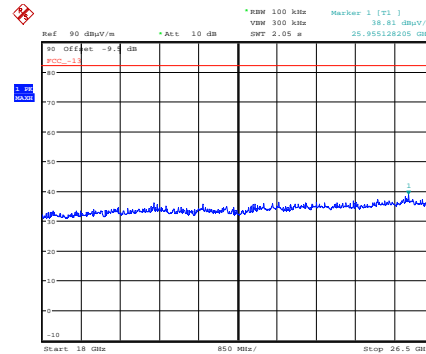

Date: 15.MAR.2019 07:55:20

18 GHz to 26.5 GHz

All emissions on graphs are related to either the cellular operation, Bluetooth LE operation and are not intermodulation products.

Bottom Channel LTE Band IV + Top Channel BLE

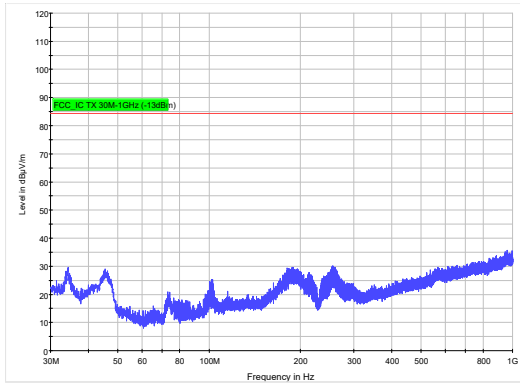

30 MHz to 1 GHz

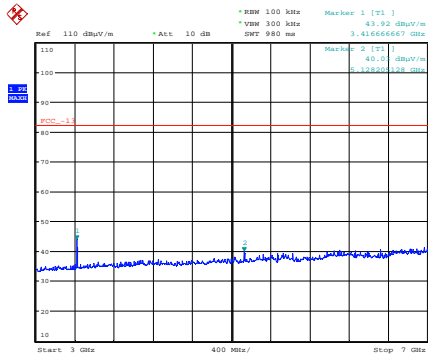

Date: 14.MAR.2019 11:20:06

3 GHz to 7 GHz

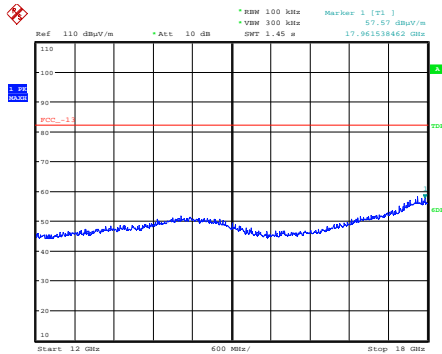

Date: 14.MAR.2019 11:09:17

12 GHz to 18 GHz

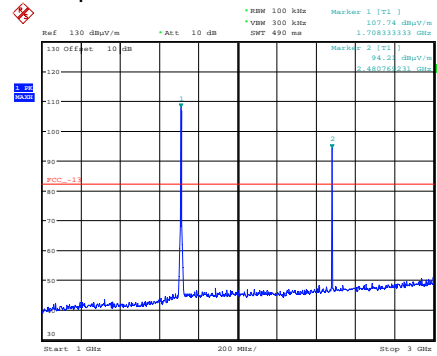

Date: 14.MAR.2019 11:23:56

1 GHz to 3 GHz

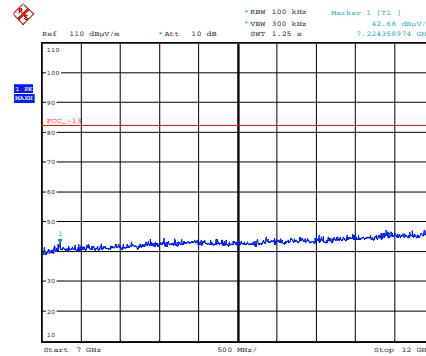

Date: 14.MAR.2019 11:06:17

7 GHz to 12 GHz

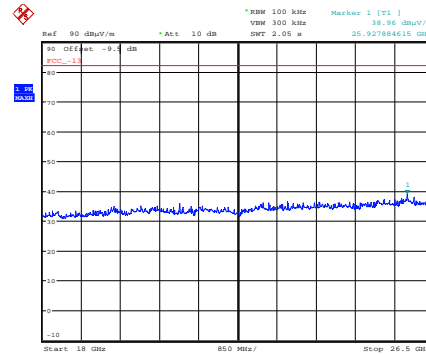

Date: 15.MAR.2019 07:17:42

18 GHz to 26.5 GHz

All emissions on graphs are related to either the cellular operation, Bluetooth LE operation and are not intermodulation products.

Top Channel LTE Band IV + Top Channel BLE

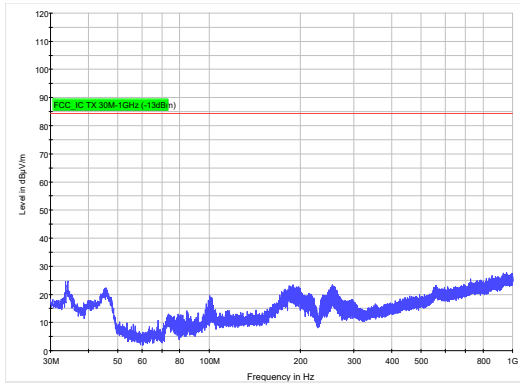

30 MHz to 1 GHz

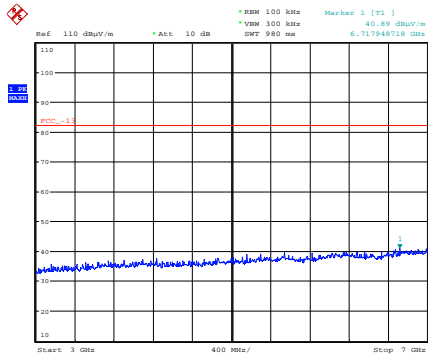

Date: 14.MAR.2019 11:15:54

3 GHz to 7 GHz

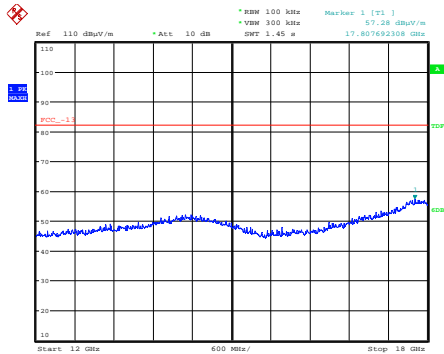

Date: 14.MAR.2019 11:10:36

12 GHz to 18 GHz

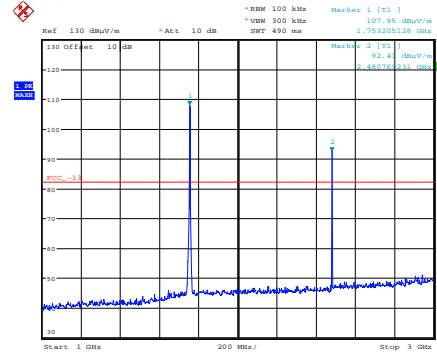

Date: 14.MAR.2019 11:50:28

1 GHz to 3 GHz

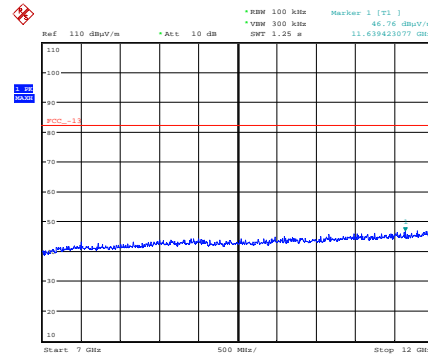

Date: 14.MAR.2019 11:13:36

7 GHz to 12 GHz

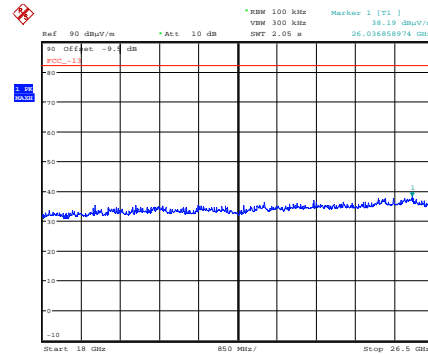

Date: 15.MAR.2019 07:18:44

18 GHz to 26.5 GHz

All emissions on graphs are related to either the cellular operation, Bluetooth LE operation and are not intermodulation products.

Bottom Channel LTE Band V + Bottom Channel BLE

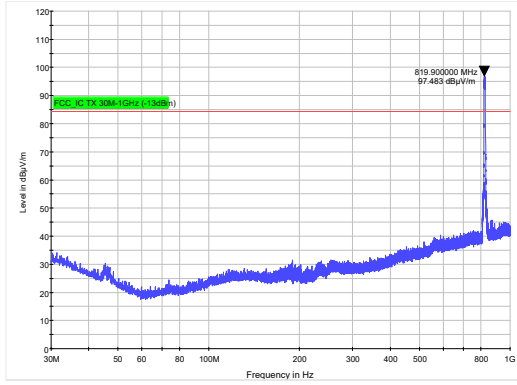

30 MHz to 1 GHz

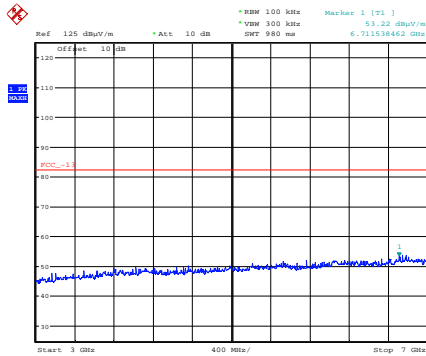

Date: 14.MAR.2019 15:58:50

3 GHz to 7 GHz

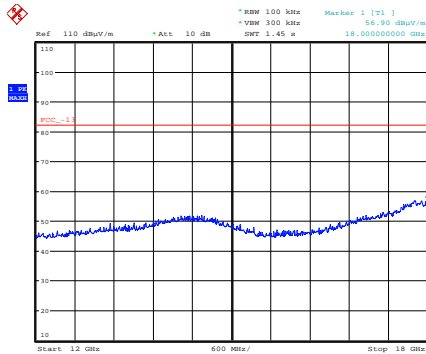

Date: 14.MAR.2019 14:57:40

12 GHz to 18 GHz

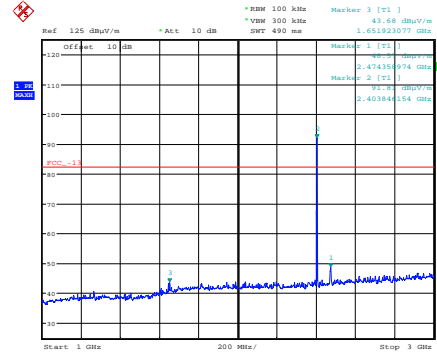

Date: 14.MAR.2019 15:58:06

1 GHz to 3 GHz

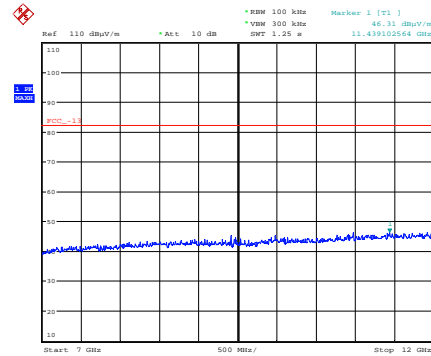

Date: 14.MAR.2019 14:58:47

7 GHz to 12 GHz

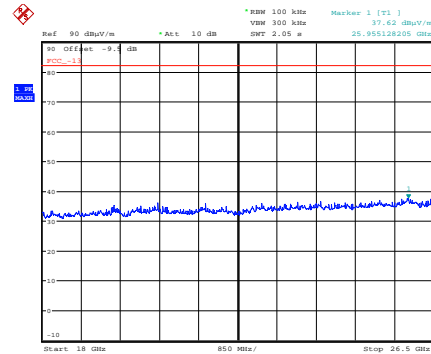

Date: 15.MAR.2019 07:58:26

18 GHz to 26.5 GHz

All emissions on graphs are related to either the cellular operation, Bluetooth LE operation and are not intermodulation products.

Top Channel LTE Band V + Bottom Channel BLE

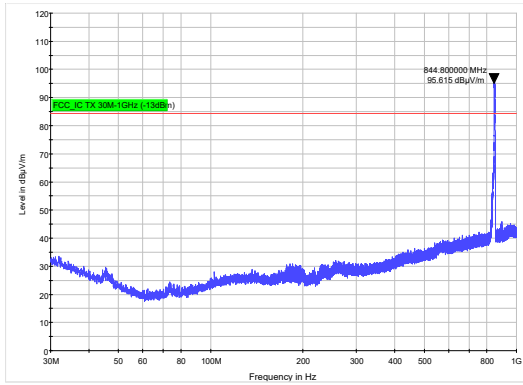

30 MHz to 1 GHz

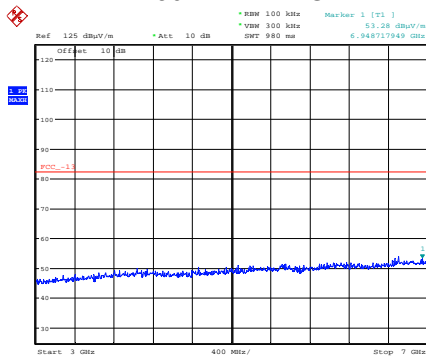

Date: 14.MAR.2019 16:05:50

3 GHz to 7 GHz

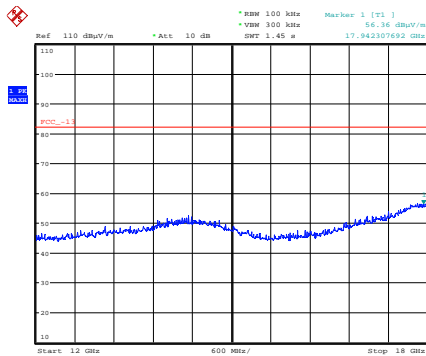

Date: 14.MAR.2019 14:39:22

12 GHz to 18 GHz

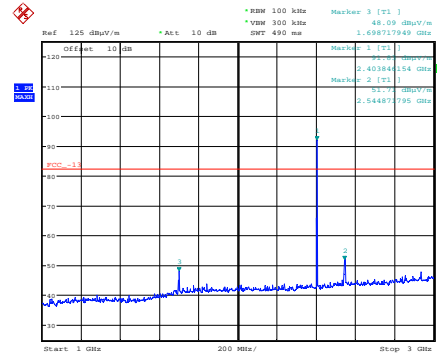

Date: 14.MAR.2019 16:07:12

1 GHz to 3 GHz

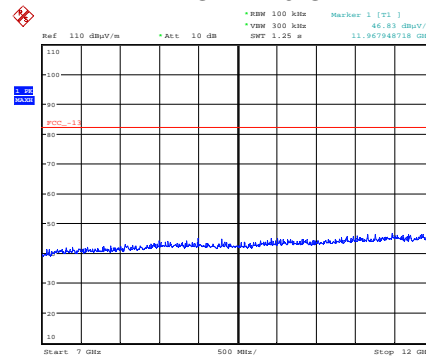

Date: 14.MAR.2019 14:38:38

7 GHz to 12 GHz

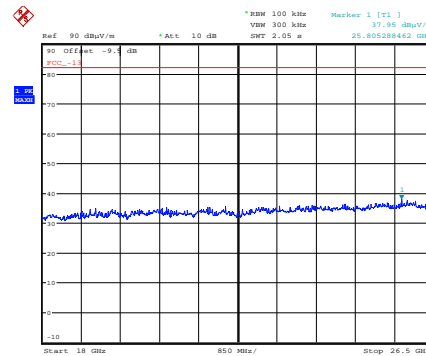

Date: 15.MAR.2019 07:59:27

18 GHz to 26.5 GHz

All emissions on graphs are related to either the cellular operation, Bluetooth LE operation and are not intermodulation products.

Bottom Channel LTE Band V + Top Channel BLE

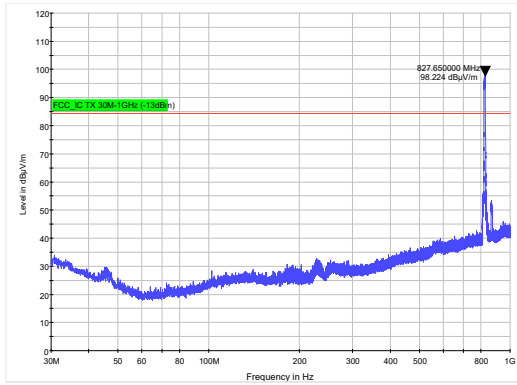

30 MHz to 1 GHz

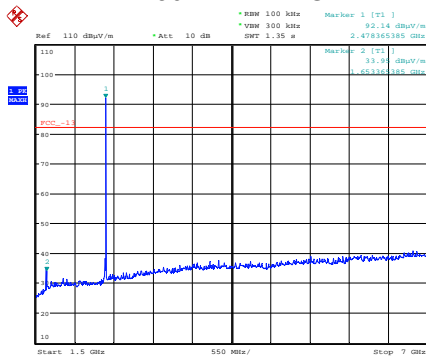

Date: 14.MAR.2019 12:04:39

1.5 GHz to 7 GHz

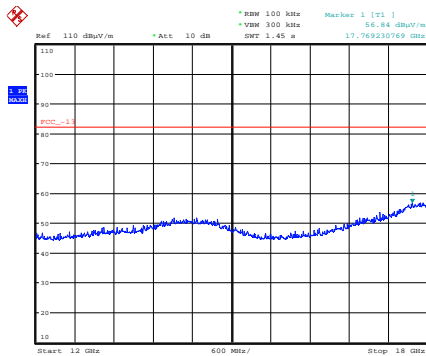

Date: 14.MAR.2019 12:10:42

12 GHz to 18 GHz

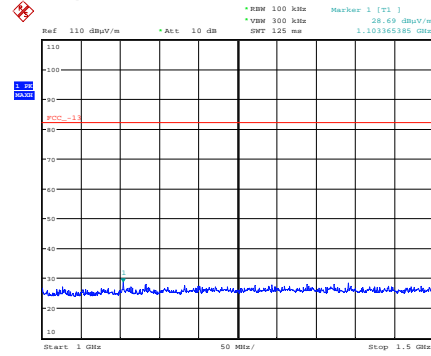

Date: 14.MAR.2019 11:57:40

1 GHz to 1.5 GHz

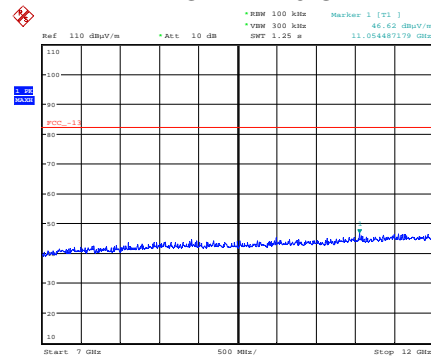

Date: 14.MAR.2019 12:09:44

7 GHz to 12 GHz

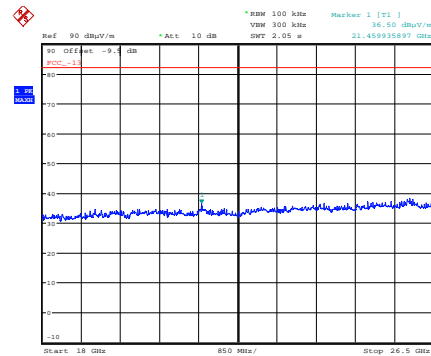

Date: 15.MAR.2019 07:21:54

18 GHz to 26.5 GHz

All emissions on graphs are related to either the cellular operation, Bluetooth LE operation and are not intermodulation products.

Top Channel LTE Band V + Top Channel BLE

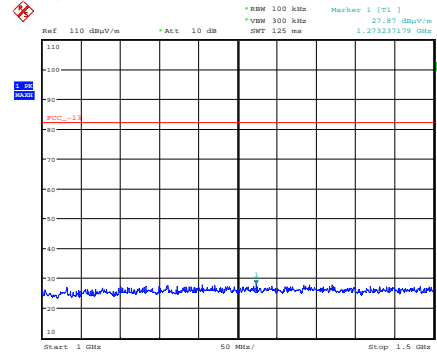
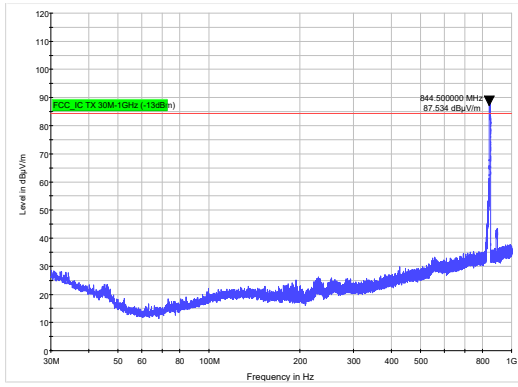

Date: 14.MAR.2019 11:58:42

30 MHz to 1 GHz

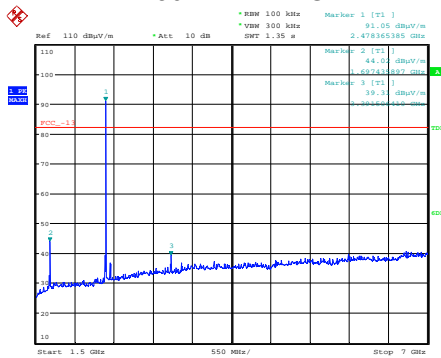

Date: 14.MAR.2019 12:03:28

1 GHz to 1.5 GHz

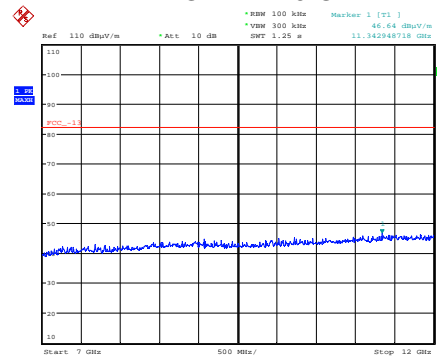

Date: 14.MAR.2019 12:14:54

1.5 GHz to 7 GHz

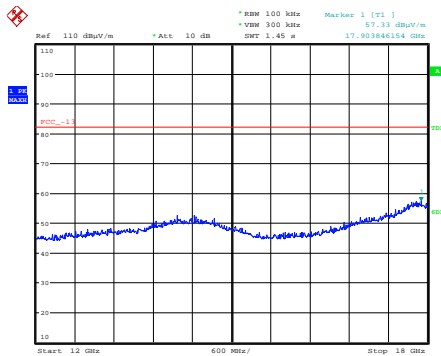

Date: 14.MAR.2019 12:13:50

7 GHz to 12 GHz

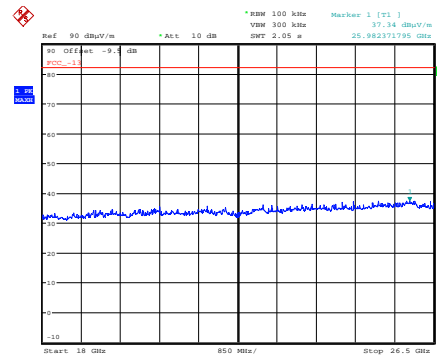

Date: 15.MAR.2019 07:23:05

12 GHz to 18 GHz

18 GHz to 26.5 GHz

All emissions on graphs are related to either the cellular operation, Bluetooth LE operation and are not intermodulation products.

Bottom Channel LTE Band VII + Bottom Channel BLE

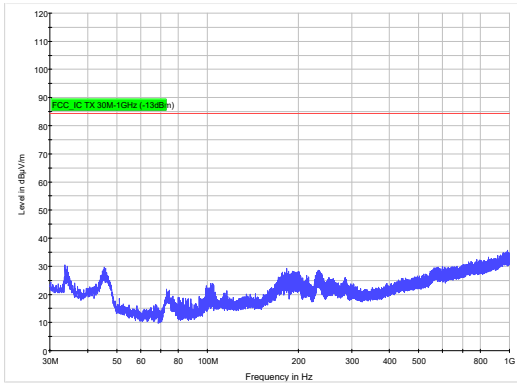

30 MHz to 1 GHz

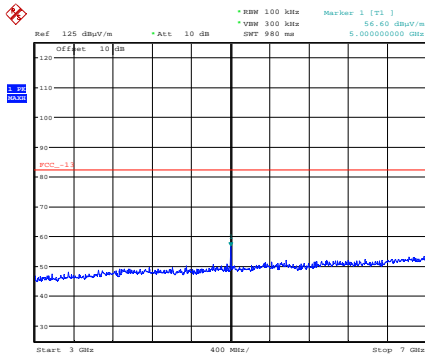

Date: 14.MAR.2019 16:11:49

3 GHz to 7 GHz

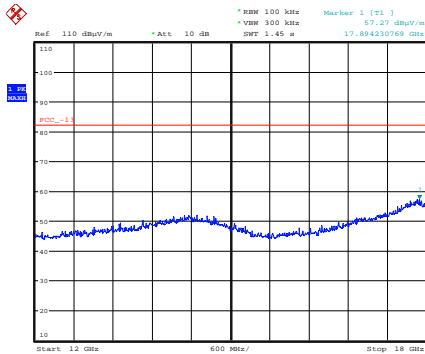

Date: 14.MAR.2019 14:21:20

12 GHz to 18 GHz

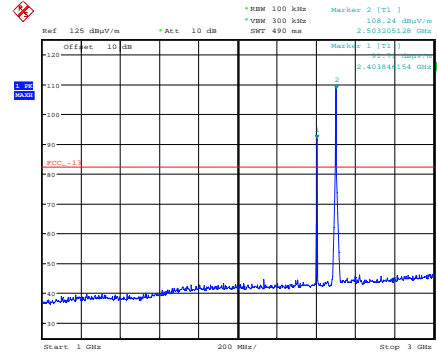

Date: 14.MAR.2019 16:10:44

1 GHz to 3 GHz

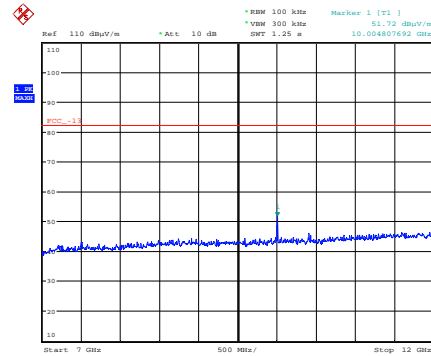

Date: 14.MAR.2019 14:22:31

7 GHz to 12 GHz

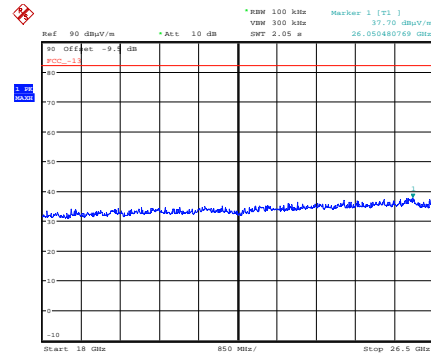

Date: 15.MAR.2019 08:02:31

18 GHz to 26.5 GHz

All emissions on graphs are related to either the cellular operation, Bluetooth LE operation and are not intermodulation products.

Top Channel LTE Band VII + Bottom Channel BLE

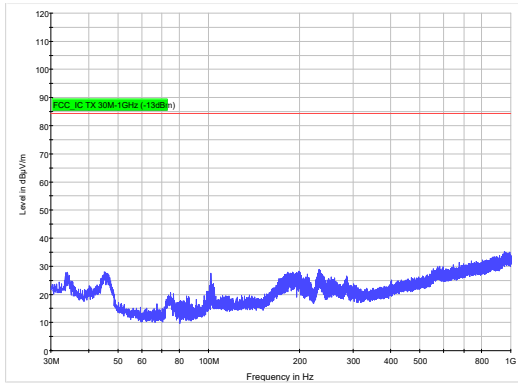

30 MHz to 1 GHz

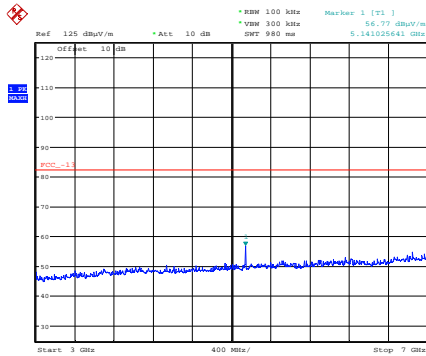

Date: 14.MAR.2019 16:18:26

3 GHz to 7 GHz

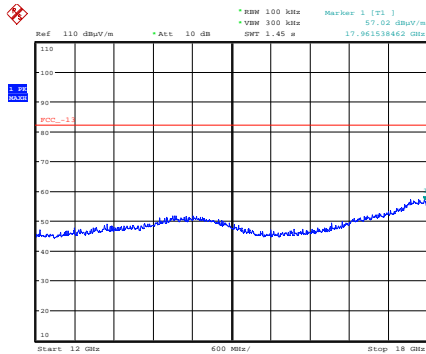

Date: 14.MAR.2019 14:14:23

12 GHz to 18 GHz

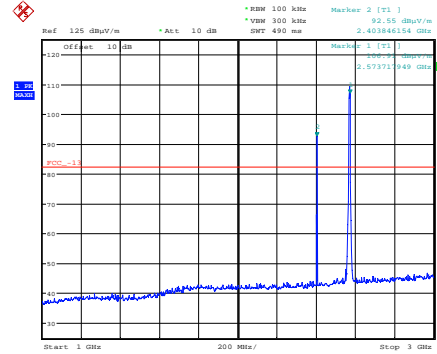

Date: 14.MAR.2019 16:19:51

1 GHz to 3 GHz

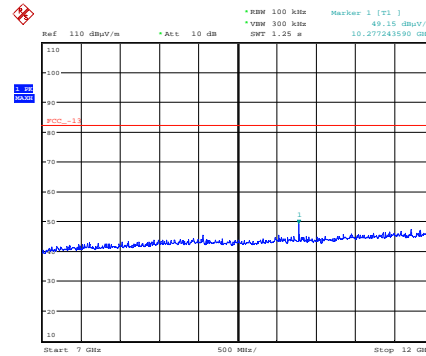

Date: 14.MAR.2019 14:32:48

7 GHz to 12 GHz

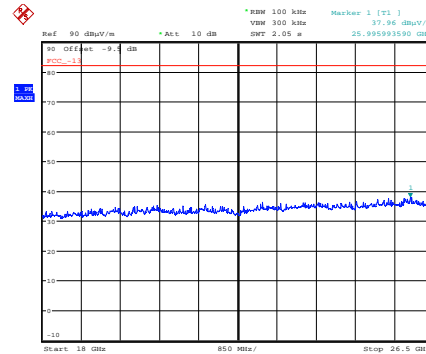

Date: 15.MAR.2019 08:03:32

18 GHz to 26.5 GHz

All emissions on graphs are related to either the cellular operation, Bluetooth LE operation and are not intermodulation products.

Bottom Channel LTE Band VII + Top Channel BLE

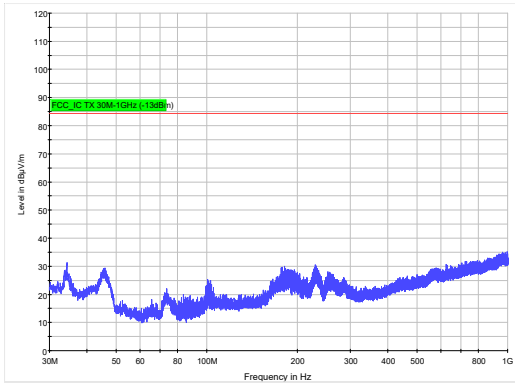

30 MHz to 1 GHz

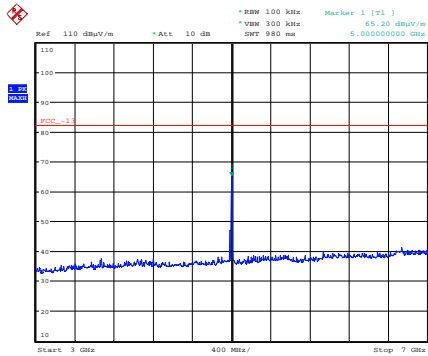

Date: 14.MAR.2019 12:30:06

3 GHz to 7 GHz

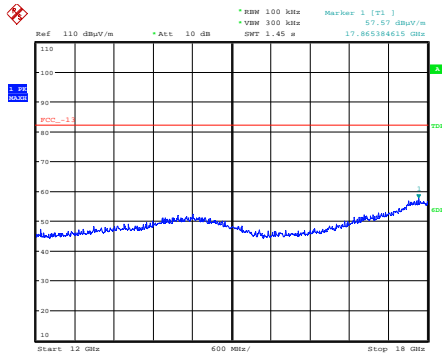

Date: 14.MAR.2019 12:25:09

12 GHz to 18 GHz

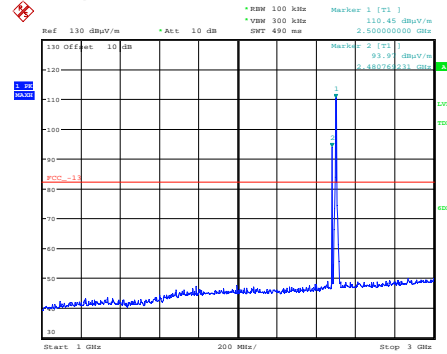

Date: 14.MAR.2019 12:59:32

1 GHz to 3 GHz

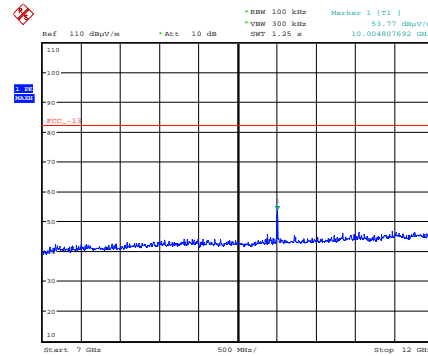

Date: 14.MAR.2019 12:19:01

7 GHz to 12 GHz

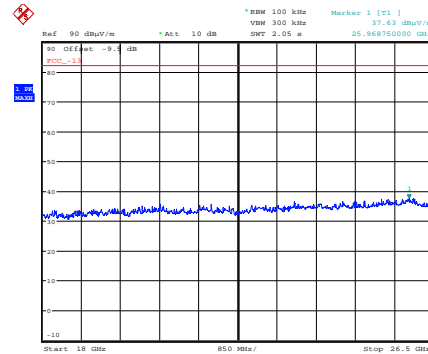

Date: 15.MAR.2019 07:26:10

18 GHz to 26.5 GHz

All emissions on graphs are related to either the cellular operation, Bluetooth LE operation and are not intermodulation products.

Top Channel LTE Band VII + Top Channel BLE

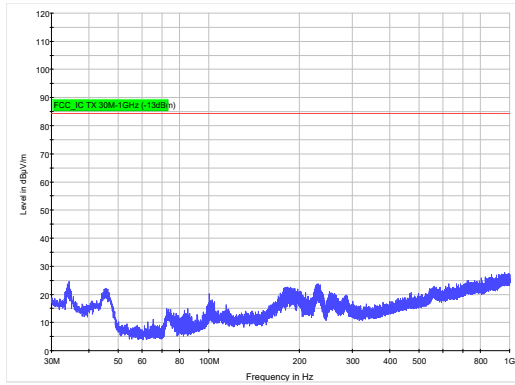

30 MHz to 1 GHz

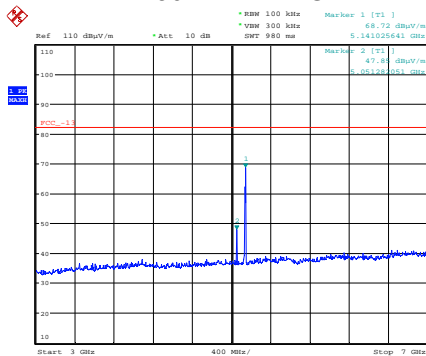

Date: 14.MAR.2019 12:32:32

3 GHz to 7 GHz

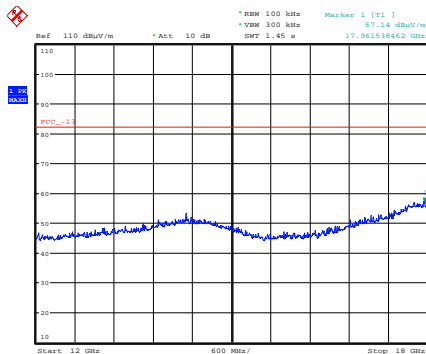

Date: 14.MAR.2019 12:23:51

12 GHz to 18 GHz

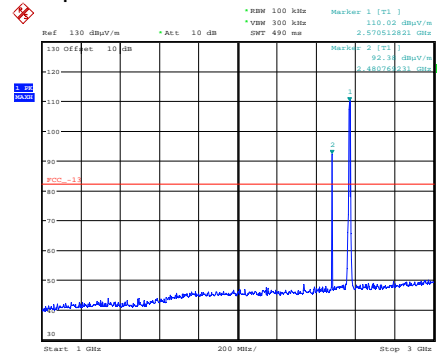

Date: 14.MAR.2019 12:56:30

1 GHz to 3 GHz

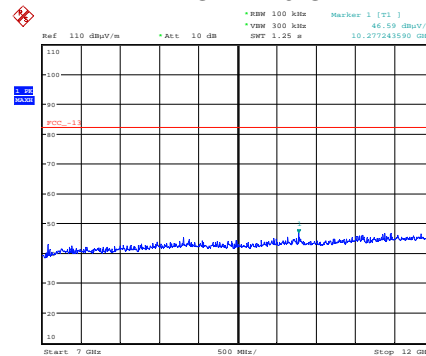

Date: 14.MAR.2019 12:20:03

7 GHz to 12 GHz

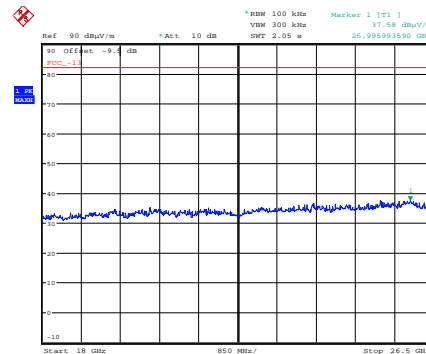

Date: 15.MAR.2019 07:27:15

18 GHz to 26.5 GHz

All emissions on graphs are related to either the cellular operation, Bluetooth LE operation, intermodulation present between 3 GHz and 7 GHz is at a level which does not exceed the spurious limit.

Bottom Channel LTE Band XII + Bottom Channel BLE

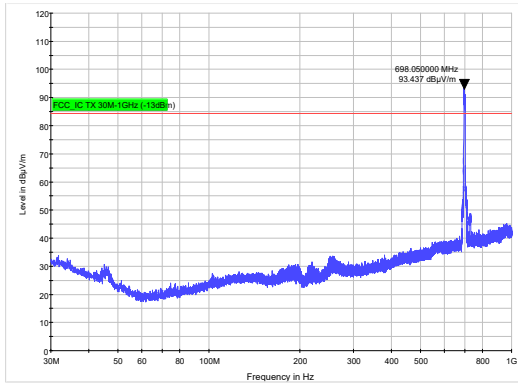

30 MHz to 1 GHz

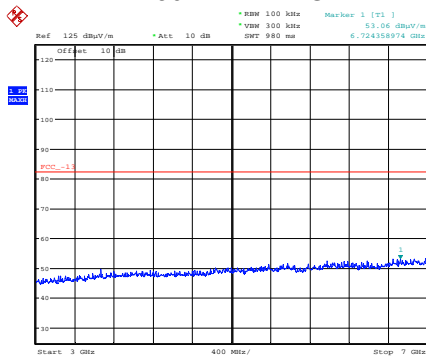

Date: 14.MAR.2019 16:29:52

3 GHz to 7 GHz

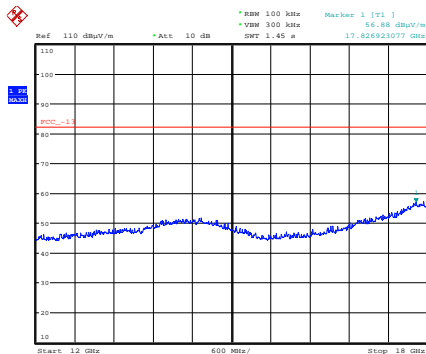

Date: 14.MAR.2019 14:00:05

12 GHz to 18 GHz

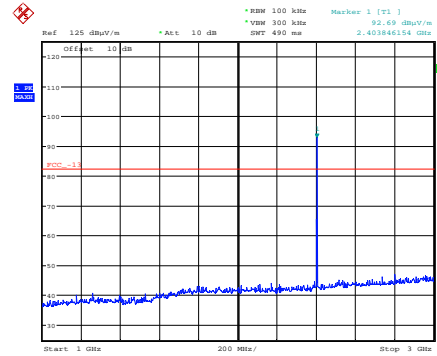

Date: 14.MAR.2019 16:30:43

1 GHz to 3 GHz

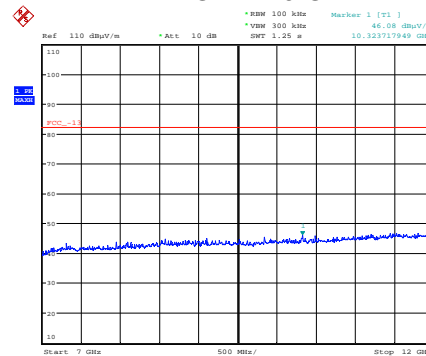

Date: 14.MAR.2019 13:59:09

7 GHz to 12 GHz

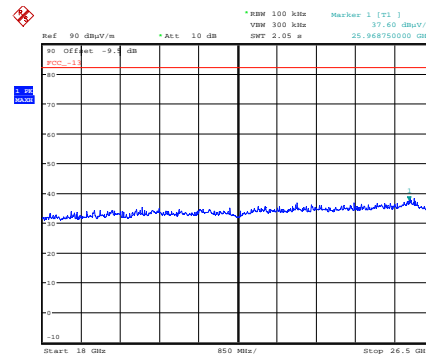

Date: 15.MAR.2019 08:07:12

18 GHz to 26.5 GHz

All emissions on graphs are related to either the cellular operation, Bluetooth LE operation and are not intermodulation products.

Top Channel LTE Band XII + Bottom Channel BLE

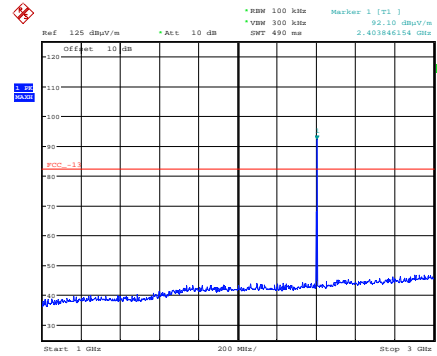
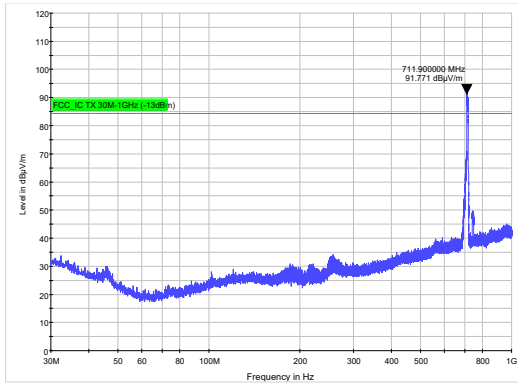

Date: 14.MAR.2019 16:23:56

30 MHz to 1 GHz

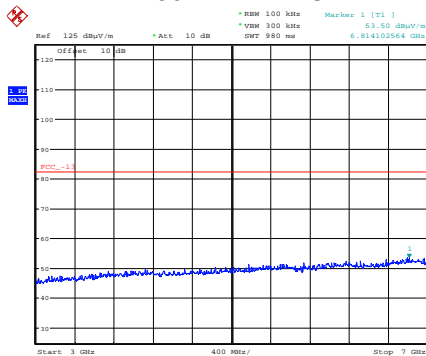

Date: 14.MAR.2019 16:25:07

1 GHz to 3 GHz

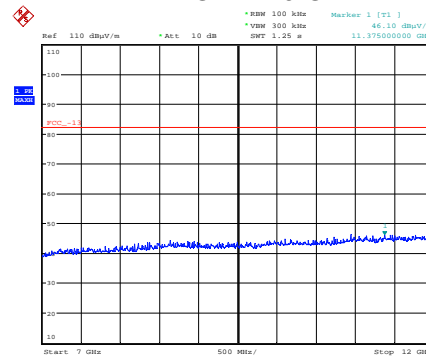

Date: 14.MAR.2019 14:10:02

3 GHz to 7 GHz

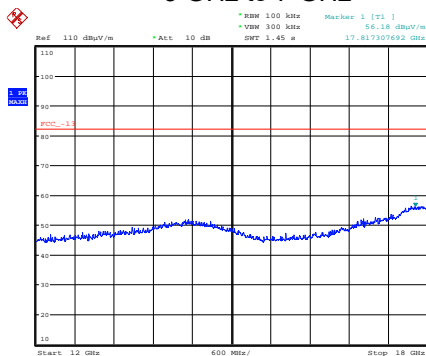

Date: 14.MAR.2019 14:09:07

7 GHz to 12 GHz

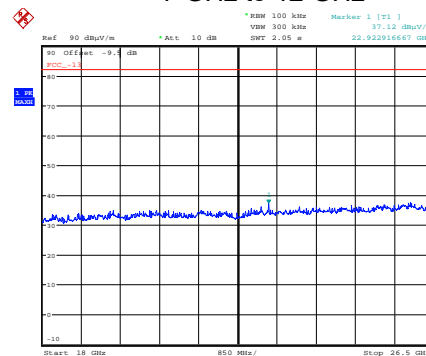

Date: 15.MAR.2019 08:20:52

12 GHz to 18 GHz

18 GHz to 26.5 GHz

All emissions on graphs are related to either the cellular operation, Bluetooth LE operation and are not intermodulation products.

Bottom Channel LTE Band XII + Top Channel BLE

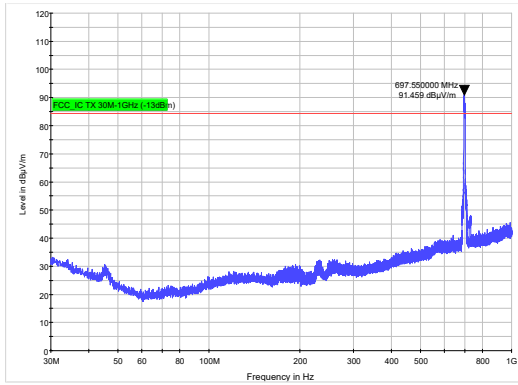

30 MHz to 1 GHz

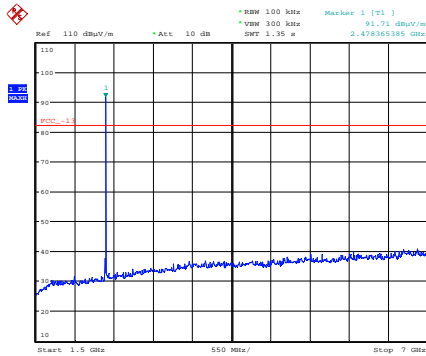

Date: 14.MAR.2019 13:31:28

1.5 GHz to 7 GHz

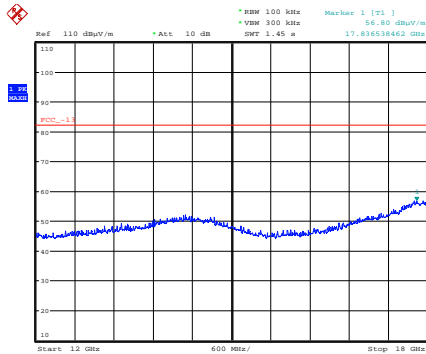

Date: 14.MAR.2019 13:41:16

12 GHz to 18 GHz

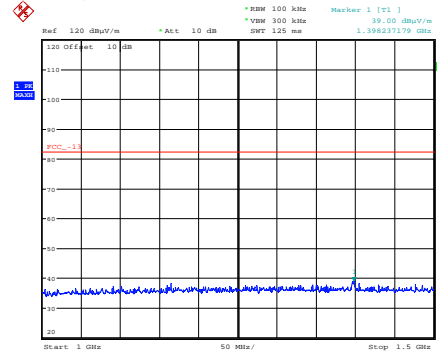

Date: 14.MAR.2019 13:20:16

1 GHz to 1.5 GHz

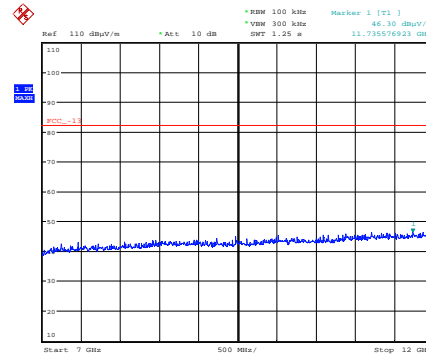

Date: 14.MAR.2019 13:35:16

7 GHz to 12 GHz

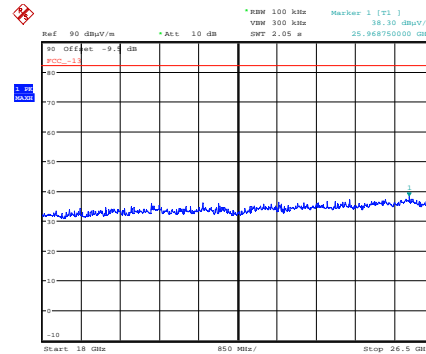

Date: 15.MAR.2019 07:30:22

18 GHz to 26.5 GHz

All emissions on graphs are related to either the cellular operation, Bluetooth LE operation and are not intermodulation products.

Top Channel LTE Band XII + Top Channel BLE

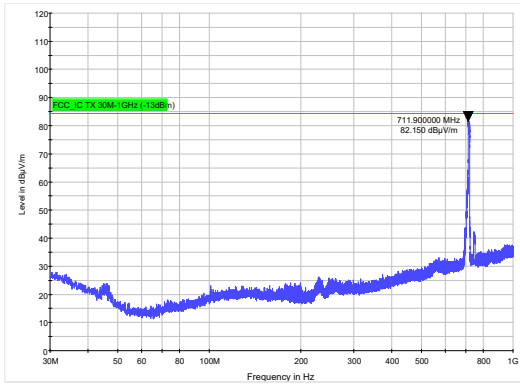

30 MHz to 1 GHz

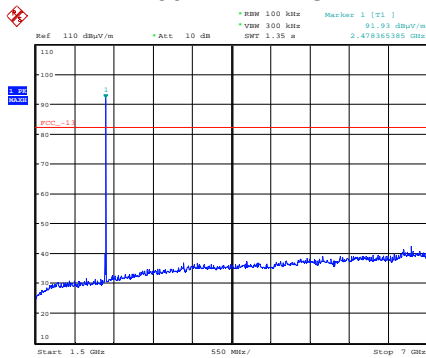

Date: 14.MAR.2019 13:30:26

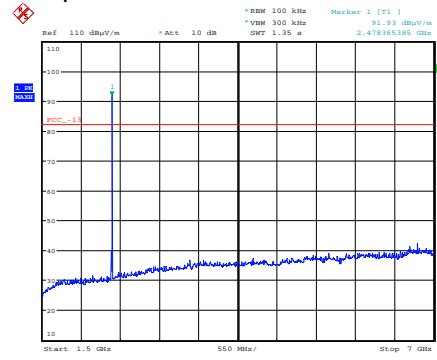

Date: 14.MAR.2019 13:30:26

1 GHz to 1.5 GHz

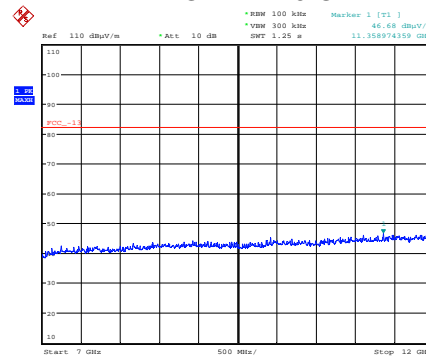

Date: 14.MAR.2019 13:36:22

1.5 GHz to 7 GHz

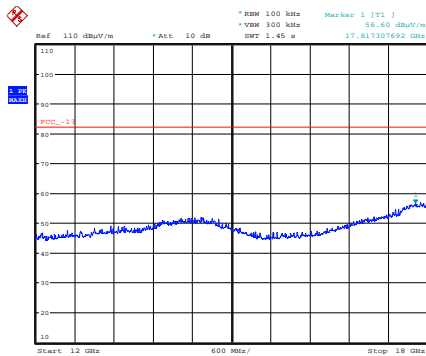

Date: 14.MAR.2019 13:38:28

7 GHz to 12 GHz

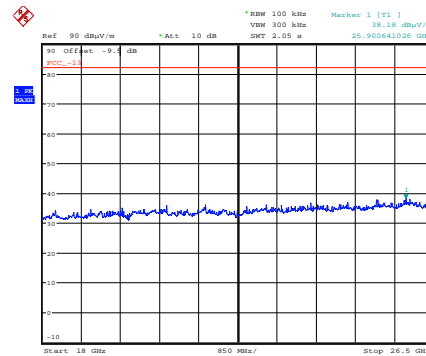

Date: 15.MAR.2019 07:31:30

12 GHz to 18 GHz

18 GHz to 26.5 GHz

All emissions on graphs are related to either the cellular operation, Bluetooth LE operation and are not intermodulation products.

11 Measurement Uncertainty

Calculated Measurement Uncertainties

All statements of uncertainty are expanded standard uncertainty using a coverage factor of 1.96 to give a 95 % confidence:

[1] Radiated spurious emissions

Uncertainty in test result (30 MHz to 1 GHz) = **4.6 dB**

Uncertainty in test result (1 GHz to 18 GHz) = **4.7 dB**