FCC Test Report

Report No.: AGC00924150303FE03

FCC ID : QIF-A009
APPLICATION PURPOSE : Original Equipment
PRODUCT DESIGNATION : Bluetooth Selfie remote
BRAND NAME : My Music
MODEL NAME : A009, A003
CLIENT : My Music Group Limited
DATE OF ISSUE : Apr.03,2015
STANDARD(S)
TEST PROCEDURE(S) : FCC Part 15 Rules
REPORT VERSION : V1.0

Attestation of *Global Compliance (Shenzhen) Co., Ltd*

CAUTION:

This report shall not be reproduced except in full without the written permission of the test laboratory and shall not be quoted out of context.



Report Revise Record

Report Version	Revise Time	Issued Date	Valid Version	Notes
V1.0	/	Apr.03,2015	Valid	Original Report

TABLE OF CONTENTS

1. VERIFICATION OF CONFORMITY	4
2. GENERAL INFORMATION	5
2.1. PRODUCT DESCRIPTION.....	5
2.2. TABLE OF CARRIER FREQUENCYS.....	5
3. MEASUREMENT UNCERTAINTY.....	6
4. DESCRIPTION OF TEST MODES.....	6
5. SYSTEM TEST CONFIGURATION	6
5.1. CONFIGURATION OF EUT SYSTEM	6
5.2. EQUIPMENT USED IN EUT SYSTEM	7
5.3. SUMMARY OF TEST RESULTS	7
6. TEST FACILITY	8
7 ALL TEST EQUIPMENT LIST	8
8. RADIATED EMISSION	9
8.1TEST LIMIT.....	9
8.2. MEASUREMENT PROCEDURE	10
8.3. TEST SETUP.....	12
8.4. TEST RESULT(Worst modulation:GFSK).....	14
9. BAND EDGE EMISSION	27
9.1. MEASUREMENT PROCEDURE	27
9.2 TEST SETUP	27
9.3 RADIATED TEST RESULT(Worst modulation:GFSK).....	28
10. FCC LINE CONDUCTED EMISSION TEST	32
10.1. LIMITS OF LINE CONDUCTED EMISSION TEST	32
10.2. BLOCK DIAGRAM OF LINE CONDUCTED EMISSION TEST	32
10.3. PRELIMINARY PROCEDURE OF LINE CONDUCTED EMISSION TEST	33
10.4. FINAL PROCEDURE OF LINE CONDUCTED EMISSION TEST	33
10.5. TEST RESULT OF LINE CONDUCTED EMISSION TEST	33
APPENDIX A: PHOTOGRAPHS OF TEST SETUP	34
APPENDIX B: PHOTOGRAPHS OF EUT	35

1. VERIFICATION OF CONFORMITY

Applicant	My Music Group Limited
Address	Room2026, Global Logistics Service Center, China South City, Pinghu Town, Long Gang District, Shenzhen 518111, China
Manufacturer	Dongguan Fulun Electronic Co.,Limited
Address	4F, Building A, Huangjinye Industrial park, No.216Shaxin Road, Keyuan City,Tangxia, Dongguan.CN
Product Designation	Bluetooth Selfie remote
Brand Name	My Music
Test Model	A009
Date of test	Apr.01,2015 to Apr.02,2015
Different Description	All the same except for the model and color.
Deviation	None
Condition of Test Sample	Normal
Report Template	AGCRT-US-BR/RF

We hereby certify that:

The above equipment was tested by Shenzhen STS Test Services Co., Ltd. The test data, data evaluation, test procedures, and equipment configurations shown in this report were made in accordance with the procedures given in ANSI C63.4 (2009) and the energy emitted by the sample EUT tested as described in this report is in compliance with radiated emission limits of FCC Rules Part 15.249.

Prepared By

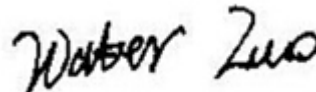

Water Zuo Apr.03,2015

Checked By



Forrest Lei Apr.03,2015

Authorized By



Solger Zhang Apr.03,2015

2. GENERAL INFORMATION

2.1. PRODUCT DESCRIPTION

A major technical description of EUT is described as following

Operation Frequency	2.402 GHz to 2.480GHz
RF Output Power	3.58dBm(Max)
Bluetooth Version	V3.0
Modulation	GFSK
Number of channels	79
Hardware Version	V1.0
Software Version	V1.0
Antenna Designation	PCB Antenna (Met 15.203 Antenna requirement)
Antenna Gain	0dBi
Power Supply	DC3V

2.2. TABLE OF CARRIER FREQUENCIES

Frequency Band	Channel Number	Frequency
2400~2483.5MHZ	0	2402MHZ
	1	2403MHZ
	:	:
	38	2440 MHZ
	39	2441 MHZ
	40	2442 MHZ
	:	:
	77	2479 MHZ
	78	2480 MHZ

3. MEASUREMENT UNCERTAINTY

The reported uncertainty of measurement $y \pm U$, where expanded uncertainty U is based on a standard uncertainty multiplied by a coverage factor of $k=2$, providing a level of confidence of approximately 95 %.

No.	Item	Uncertainty
1	Conducted Emission Test	$\pm 3.18\text{dB}$
2	All emissions, radiated	$\pm 3.91\text{dB}$
3	Temperature	$\pm 0.5^\circ\text{C}$
4	Humidity	$\pm 2\%$

4. DESCRIPTION OF TEST MODES

NO.	TEST MODE DESCRIPTION
1	Low channel GFSK
2	Middle channel GFSK
3	High channel GFSK
10	Normal operation (BT)

Note:

- All the test modes can be supply by battery, only the result of the worst case was recorded in the report, if no other cases.
- For Radiated Emission, 3axis were chosen for testing for each applicable mode.

5. SYSTEM TEST CONFIGURATION

5.1. CONFIGURATION OF EUT SYSTEM

Configure 1: (Normal hopping)

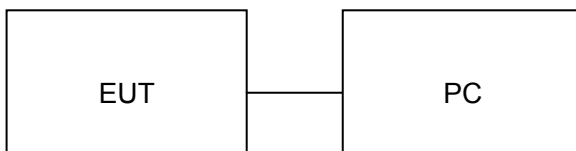

Configure 2: (Control continuous TX)

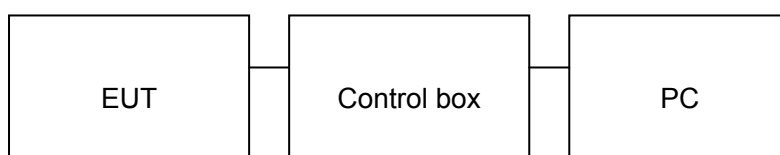

5.2. EQUIPMENT USED IN EUT SYSTEM

Item	Equipment	Model No.	ID or Specification	Remark
1	Bluetooth Selfie remote	My Music	A009	EUT
2	Control box	N/A	N/A	A.E
3	PC	Dell	A1465	A.E

5.3. SUMMARY OF TEST RESULTS

FCC RULES	DESCRIPTION OF TEST	RESULT
§15.249	Radiated Emission	Compliant
§15.249	Band Edges	Compliant
§15.207	Conduction Emission	Compliant

6. TEST FACILITY

Site	Shenzhen STS Test Services Co., Ltd.
Location	1/F, Building 2, Zhuoke Science Park, Chongqing Road, Fuyong, Baoan District, Shenzhen, China.
FCC Registration No.	842334
Description	The test site is constructed and calibrated to meet the FCC requirements in documents ANSI C63.4:2009.

7 ALL TEST EQUIPMENT LIST

Radiation Test equipment

Kind of Equipment	Manufacturer	Type No.	Serial No.	Last calibration	Calibrated until
Spectrum Analyzer	Agilent	E4407B	MY50140340	2014.10.25	2015.10.24
Test Receiver	R&S	ESCI	101427	2014.10.25	2015.10.24
Bilog Antenna	TESEQ	CBL6111D	34678	2014.10.27	2015.10.26
50Ω Coaxial Switch	Anritsu	MP59B	6200264416	2014.06.06	2015.06.06
Horn Antenna	R&S	9120D	152265	2014.10.27	2015.10.26
Horn Ant	Schwarzbeck	BBHA 9170	9170-181	2014.07.06	2015.07.05
Amplifier	EM	EM-30180	060538	2014.12.22	2015.12.21
Loop Antenna	ARA	PLA-1030/B	1029	2014.06.08	2015.06.07
Power Meter	Anritsu	ML2495A	1204003	2014.10.25	2015.10.24
Power Sensor	Anritsu	MA2411B	100309	2014.10.25	2015.10.24

Conduction Test equipment

Kind of Equipment	Manufacturer	Type No.	Serial No.	Last calibration	Calibrated until
Test Receiver	R&S	102086	102086	2014.10.25	2015.10.24
LISN	R&S	ENV216	101242	2014.10.25	2015.10.24
LISN	EMCO	3810/2NM	000-23625	2014.10.25	2015.10.24
50Ω Coaxial Switch	Anritsu	MP59B	6200264417	2014.06.06	2015.06.06
Passive Voltage Probe	R&S	ESH2-Z3	100196	2014.06.06	2015.06.06
Absorbing clamp	R&S	MDS-21	100668	2014.10.27	2015.10.26

8. RADIATED EMISSION

8.1 TEST LIMIT

Standard FCC15.249

Fundamental Frequency	Field Strength of Fundamental (millivolts/meter)	Field Strength of Harmonics (microvolts/meter)
900-928MHz	50	500
2400-2483.5MHz	50	500
5725-5875MHz	50	500
24.0-24.25GHz	250	2500

Standard FCC 15.209

Frequency (MHz)	Distance Meters	Field Strengths Limit	
		μ V/m	dB(μ V)/m
0.009 ~ 0.490	300	2400/F(kHz)	---
0.490 ~ 1.705	30	24000/F(kHz)	---
1.705 ~ 30	30	30	---
30 ~ 88	3	100	40.0
88 ~ 216	3	150	43.5
216 ~ 960	3	200	46.0
960 ~ 1000	3	500	54.0
Above 1000	3	Other:74.0 dB(μ V)/m (Peak) 54.0 dB(μ V)/m (Average)	

Remark: (1) Emission level dB μ V = 20 log Emission level μ V/m
(2) The smaller limit shall apply at the cross point between two frequency bands.
(3) Distance is the distance in meters between the measuring instrument, antenna and the closest point of any part of the device or system.

8.2. MEASUREMENT PROCEDURE

1. Configure the EUT according to ANSI C63.4. The EUT was placed on the top of the turntable 0.8 meter above ground. The phase center of the receiving antenna mounted on the top of a height-variable antenna tower was placed 3 meters far away from the turntable.
2. Power on the EUT and all the supporting units. The turntable was rotated by 360 degrees to determine the position of the highest radiation.
3. The height of the broadband receiving antenna was varied between one meter and four meters above ground to find the maximum emissions field strength of both horizontal and vertical polarization.
4. For each suspected emissions, the antenna tower was scan (from 1 M to 4 M) and then the turntable was rotated (from 0 degree to 360 degrees) to find the maximum reading.
5. Set the test-receiver system to Peak or CISPR quasi-peak Detect Function with specified bandwidth under Maximum Hold Mode.
6. For emissions above 1GHz, use 1MHz VBW and RBW for peak reading. Then 1MHz RBW and 10Hz VBW for average reading in spectrum analyzer.
7. When the radiated emissions limits are expressed in terms of the average value of the emissions, and pulsed operation is employed, the measurement field strength shall be determined by averaging over one complete pulse train, including blanking intervals, as long as the pulse train does not exceed 0.1 seconds. As an alternative (provided the transmitter operates for longer than 0.1 seconds) or in cases where the pulse train exceeds 0.1 seconds, the measured field strength shall be determined from the average absolute voltage during a 0.1 second interval during which the field strength is at its maximum values.
8. If the emissions level of the EUT in peak mode was 3 dB lower than the average limit specified, then testing will be stopped and peak values of EUT will be reported, otherwise, the emissions which do not have 3 dB margin will be repeated one by one using the quasi-peak method for below 1GHz.
9. For testing above 1GHz, the emissions level of the EUT in peak mode was lower than average limit (that means the emissions level in peak mode also complies with the limit in average mode), then testing will be stopped and peak values of EUT will be reported, otherwise, the emissions will be measured in average mode again and reported.
10. In case the emission is lower than 30MHz, loop antenna has to be used for measurement and the recorded data should be QP measured by receiver. High - Low scan is not required in this case.

The following table is the setting of spectrum analyzer and receiver.

Spectrum Parameter	Setting
Start ~Stop Frequency	9KHz~150KHz/RB 200Hz for QP
Start ~Stop Frequency	150KHz~30MHz/RB 9KHz for QP
Start ~Stop Frequency	30MHz~1000MHz/RB 120KHz for QP
Start ~Stop Frequency	1GHz~26.5GHz 1MHz/1MHz for Peak, 1MHz/10Hz for Average

Receiver Parameter	Setting
Start ~Stop Frequency	9KHz~150KHz/RB 200Hz for QP
Start ~Stop Frequency	150KHz~30MHz/RB 9KHz for QP
Start ~Stop Frequency	30MHz~1000MHz/RB 120KHz for QP

8.3. TEST SETUP

Radiated Emission Test-Setup Frequency Below 30MHz

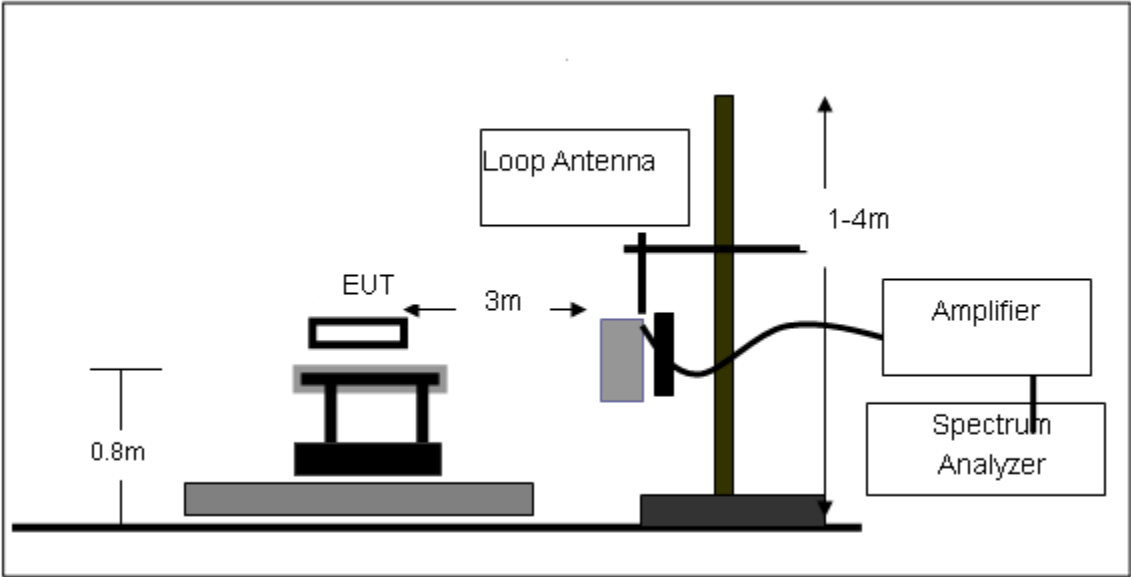

RADIATED EMISSION TEST SETUP 30MHz-1000MHz

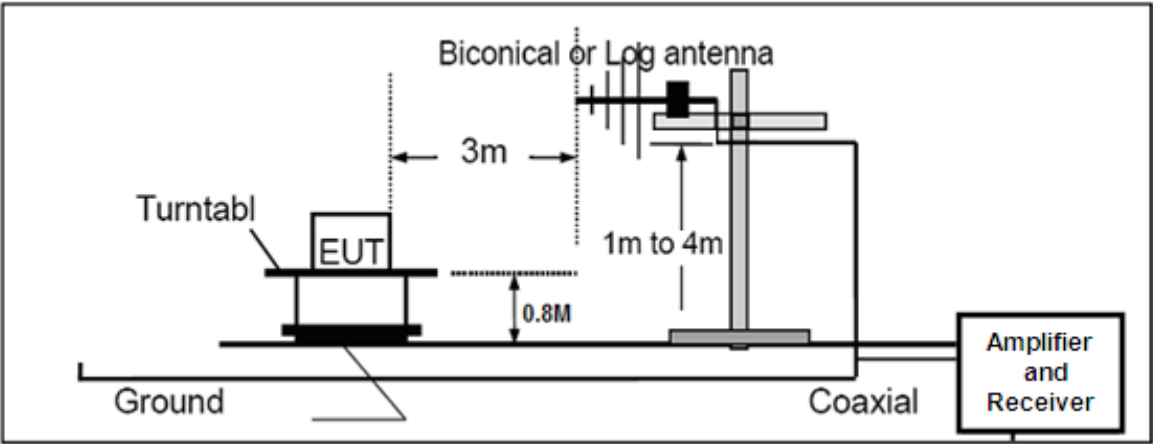

RADIATED EMISSION TEST SETUP ABOVE 1000MHz

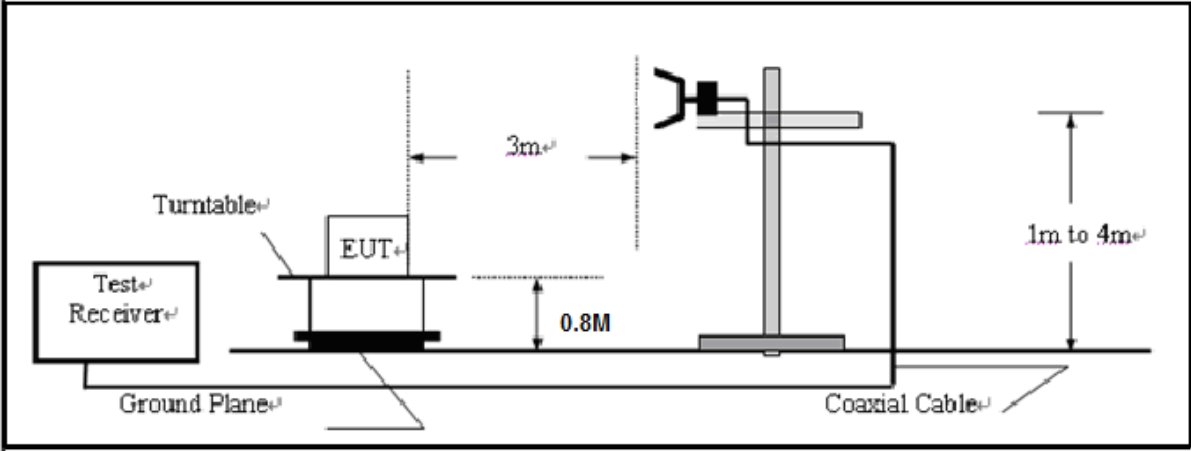

8.4. TEST RESULT(Worst modulation:GFSK)

RADIATED EMISSION BELOW 30MHZ

No emission found between lowest internal used/generated frequencies to 30MHz.

RADIATED EMISSION BELOW 1GHZ

RADIATED EMISSION TEST- (30MHZ-1GHZ)-LOW CHANNEL-HORIZONTAL

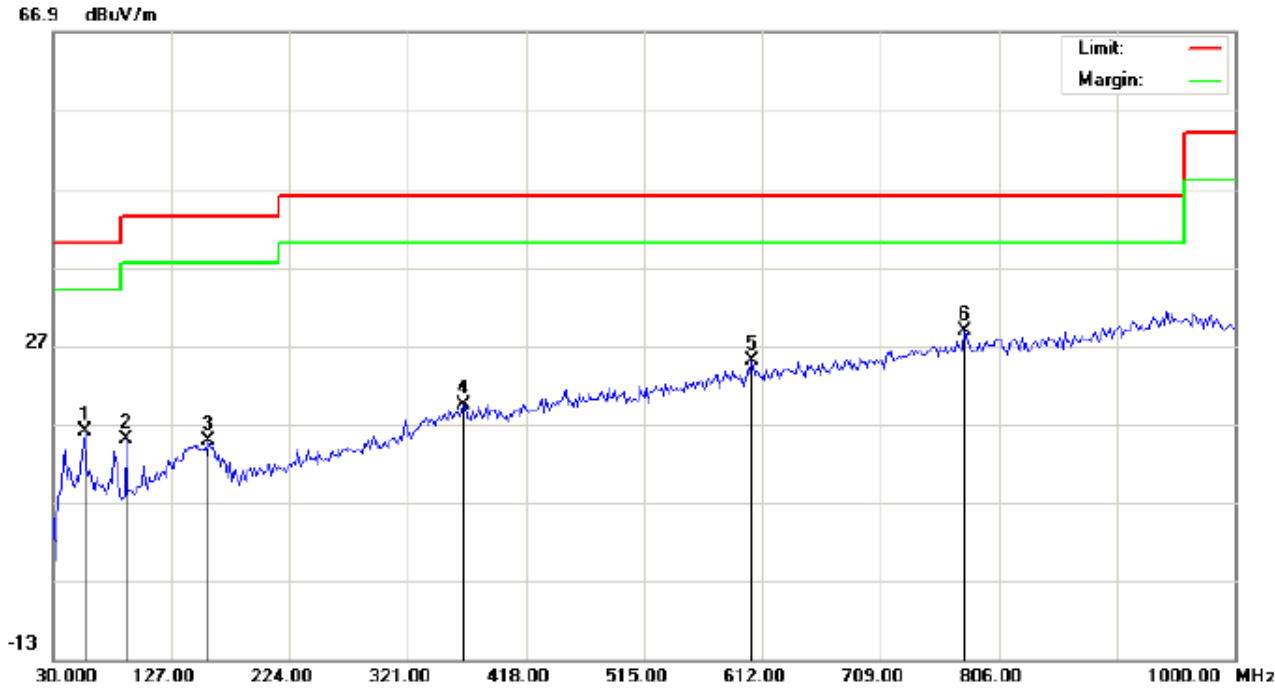

Site: site #1	Polarization: <i>Horizontal</i>	Temperature: 26
Limit: FCC Class B 3M Radiation	Power:	Humidity: 60 %
EUT: Bluetooth Selfie remote	Distance: 3m	
M/N: A009		
Mode: Low Channel TX		
Note:		

No.	Mk	Freq.	Reading	Factor	Measurement	Limit	Over	Detector	Antenna Height	Table Degree	Comment
		MHz	dBuV	dB/m	dBuV/m	dBuV/m	dB		cm	degree	
1		55.8667	4.87	11.19	16.06	40.00	-23.94	peak			
2		89.8167	5.61	9.39	15.00	43.50	-28.50	peak			
3		157.7167	-0.58	15.32	14.74	43.50	-28.76	peak			
4		366.2667	0.61	18.85	19.46	46.00	-26.54	peak			
5		603.9167	1.19	23.74	24.93	46.00	-21.07	peak			
6	*	778.5167	1.74	27.02	28.76	46.00	-17.24	peak			

RESULT: PASS

RADIATED EMISSION TEST- (30MHZ-1GHZ)-LOW CHANNEL -VERTICAL

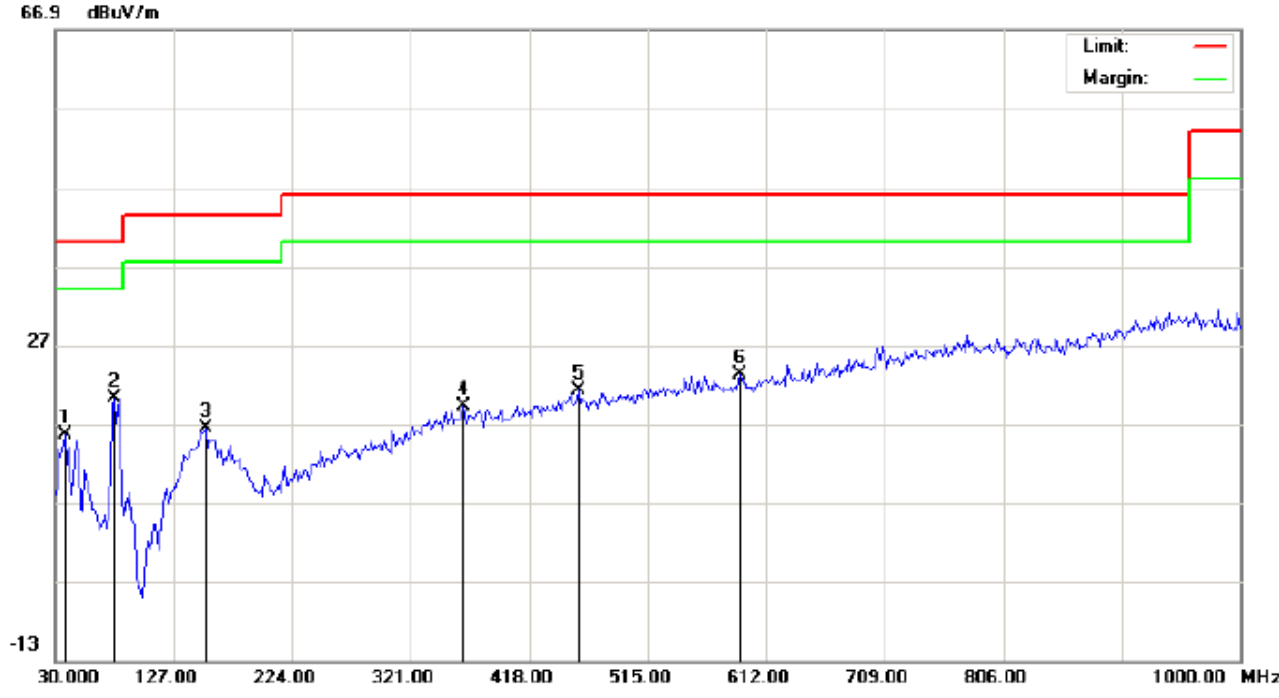

Site: site #1
 Limit: FCC Class B 3M Radiation
 EUT: Bluetooth Selfie remote
 M/N: A009
 Mode: Low Channel TX
 Note:

Polarization: *Vertical*
 Power:
 Distance: 3m

Temperature: 26
 Humidity: 60 %

No.	Mk	Freq.	Reading	Factor	Measurement	Limit	Over	Detector	Antenna Height	Table Degree	Comment
		MHz	dBuV	dB/m	dBuV/m	dBuV/m	dB		cm	degree	
1		38.0833	9.24	6.39	15.63	40.00	-24.37	peak			
2	*	78.5000	18.12	2.17	20.29	40.00	-19.71	peak			
3		152.8667	1.05	15.28	16.33	43.50	-27.17	peak			
4		364.6500	0.29	18.84	19.13	46.00	-26.87	peak			
5		458.4167	0.62	20.68	21.30	46.00	-24.70	peak			
6		590.9833	0.43	22.68	23.11	46.00	-22.89	peak			

RESULT: PASS

- Note:** 1. Factor=Antenna Factor + Cable loss, Margin=Measurement-Limit.
 2. The "Factor" value can be calculated automatically by software of measurement system.

RADIATED EMISSION TEST- (30MHZ-1GHZ)-MIDDLE CHANNEL-HORIZONTAL

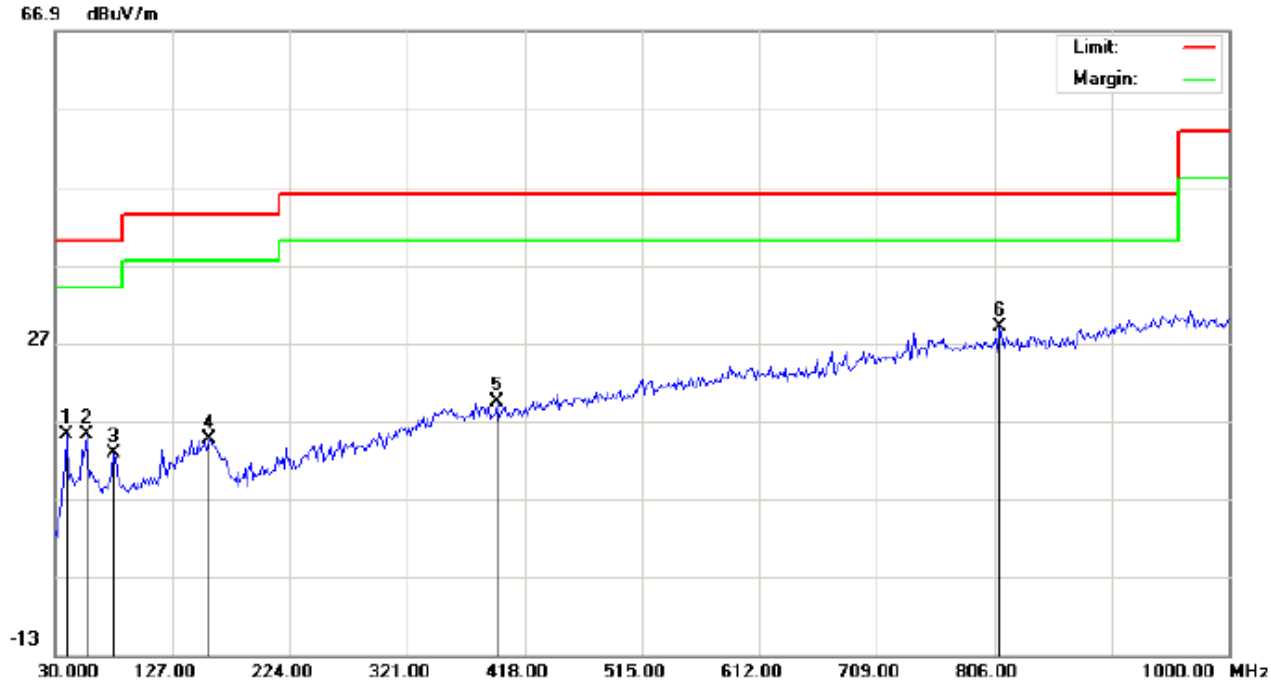

Site: site #1
 Limit: FCC Class B 3M Radiation
 EUT: Bluetooth Selfie remote
 M/N: A009
 Mode: Middle Channel TX
 Note:

Polarization: *Horizontal*
 Power:
 Distance: 3m

Temperature: 26
 Humidity: 60 %

No.	Mk	Freq.	Reading	Factor	Measurement	Limit	Over	Detector	Antenna Height	Table Degree	Comment
		MHz	dBuV	dB/m	dBuV/m	dBuV/m	dB		cm	degree	
1		39.7000	3.73	11.51	15.24	40.00	-24.76	peak			
2		55.8667	3.93	11.19	15.12	40.00	-24.88	peak			
3		78.5000	2.88	9.87	12.75	40.00	-27.25	peak			
4		157.7167	-0.74	15.32	14.58	43.50	-28.92	peak			
5		395.3667	0.31	19.04	19.35	46.00	-26.65	peak			
6	*	810.8500	1.72	27.32	29.04	46.00	-16.96	peak			

RESULT: PASS

RADIATED EMISSION TEST- (30MHZ-1GHZ)- MIDDLE CHANNEL -VERTICAL

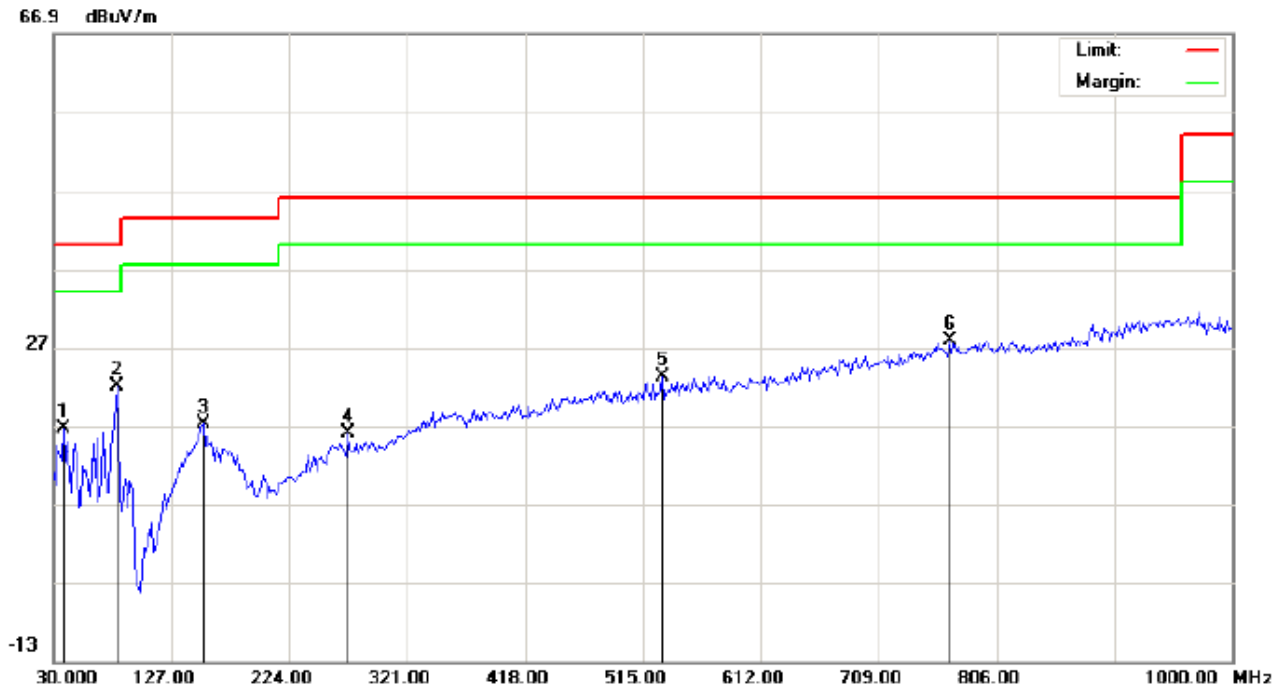

Site: site #1
Limit: FCC Class B 3M Radiation
EUT: Bluetooth Selfie remote
M/N: A009
Mode: Middle Channel TX
Note:

Polarization: *Vertical*
Power:
Distance: 3m

Temperature: 26
Humidity: 60 %

No.	Mk	Freq.	Reading	Factor	Measurement	Limit	Over	Detector	Antenna	Table	Comment
		MHz	dBuV	dB/m	dBuV/m	dBuV/m	dB		Height	Degree	
1		38.0833	10.14	6.39	16.53	40.00	-23.47	peak	cm	degree	
2	*	81.7333	19.62	2.42	22.04	40.00	-17.96	peak			
3		152.8667	1.86	15.28	17.14	43.50	-26.36	peak			
4		272.5000	1.47	14.58	16.05	46.00	-29.95	peak			
5		531.1667	1.24	21.97	23.21	46.00	-22.79	peak			
6		767.2000	0.89	26.87	27.76	46.00	-18.24	peak			

RESULT: PASS

Note: 1. Factor=Antenna Factor + Cable loss, Margin=Measurement-Limit.

2. The "Factor" value can be calculated automatically by software of measurement system.

RADIATED EMISSION TEST- (30MHZ-1GHZ)-HIGH CHANNEL-HORIZONTAL

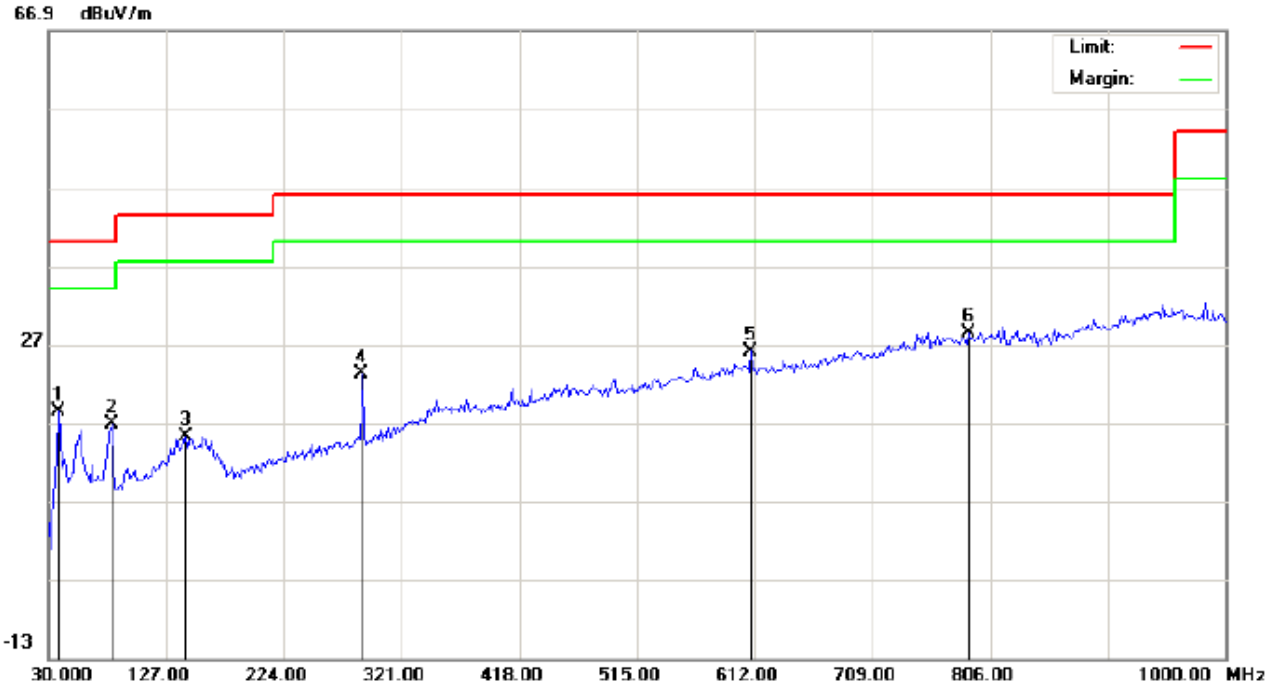

Site: site #1
 Limit: FCC Class B 3M Radiation
 EUT: Bluetooth Selfie remote
 M/N: A009
 Mode: High Channel TX
 Note:

Polarization: *Horizontal*
 Power:
 Distance: 3m

Temperature: 26
 Humidity: 60 %

No.	Mk	Freq.	Reading	Factor	Measurement	Limit	Over	Detector	Antenna	Table	Comment
		MHz	dBuV	dB/m	dBuV/m	dBuV/m	dB		Height	Degree	
									cm	degree	
1		38.0833	8.99	9.43	18.42	40.00	-21.58	peak			
2		81.7333	7.01	9.73	16.74	40.00	-23.26	peak			
3		143.1667	0.07	15.22	15.29	43.50	-28.21	peak			
4		288.6666	8.13	15.07	23.20	46.00	-22.80	peak			
5		608.7667	2.35	23.75	26.10	46.00	-19.90	peak			
6	*	788.2167	1.24	27.16	28.40	46.00	-17.60	peak			

RESULT: PASS

RADIATED EMISSION TEST- (30MHZ-1GHZ)-HIGH CHANNEL -VERTICAL

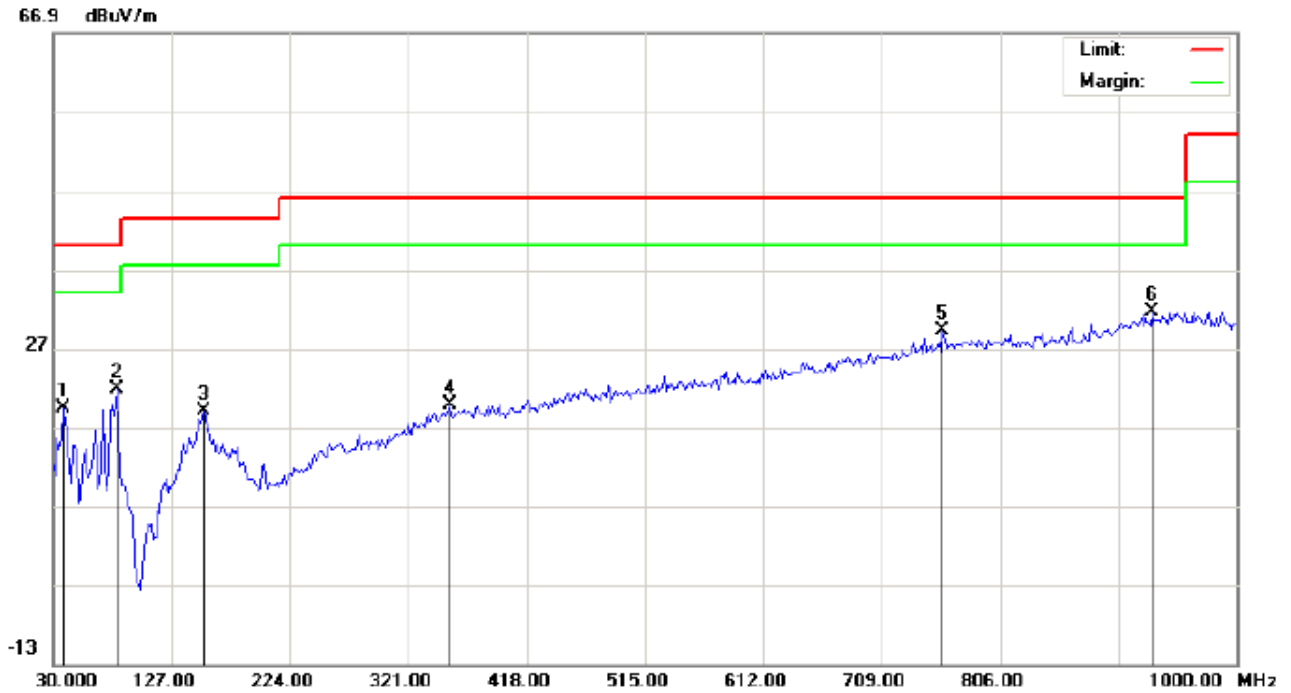

Site: site #1
 Limit: FCC Class B 3M Radiation
 EUT: Bluetooth Selfie remote
 M/N: A009
 Mode: High Channel TX
 Note:

Polarization: *Vertical*
 Power:
 Distance: 3m

Temperature: 26
 Humidity: 60 %

No.	Mk	Freq.	Reading	Factor	Measurement	Limit	Over	Detector	Antenna Height	Table Degree	Comment
		MHz	dBuV	dB/m	dBuV/m	dBuV/m	dB		cm	degree	
1		38.0833	13.02	6.39	19.41	40.00	-20.59	peak			
2		81.7333	19.32	2.42	21.74	40.00	-18.26	peak			
3		152.8667	3.66	15.28	18.94	43.50	-24.56	peak			
4		354.9500	1.00	18.77	19.77	46.00	-26.23	peak			
5		759.1167	2.45	26.76	29.21	46.00	-16.79	peak			
6	*	930.4833	2.16	29.46	31.62	46.00	-14.38	peak			

RESULT: PASS

Note: 1. Factor=Antenna Factor + Cable loss, Margin=Measurement-Limit.

2. The "Factor" value can be calculated automatically by software of measurement system.

RADIATED EMISSION ABOVE 1GHZ

RADIATED EMISSION TEST- (ABOVE 1GHZ)-LOW CHANNEL-HORIZONTAL

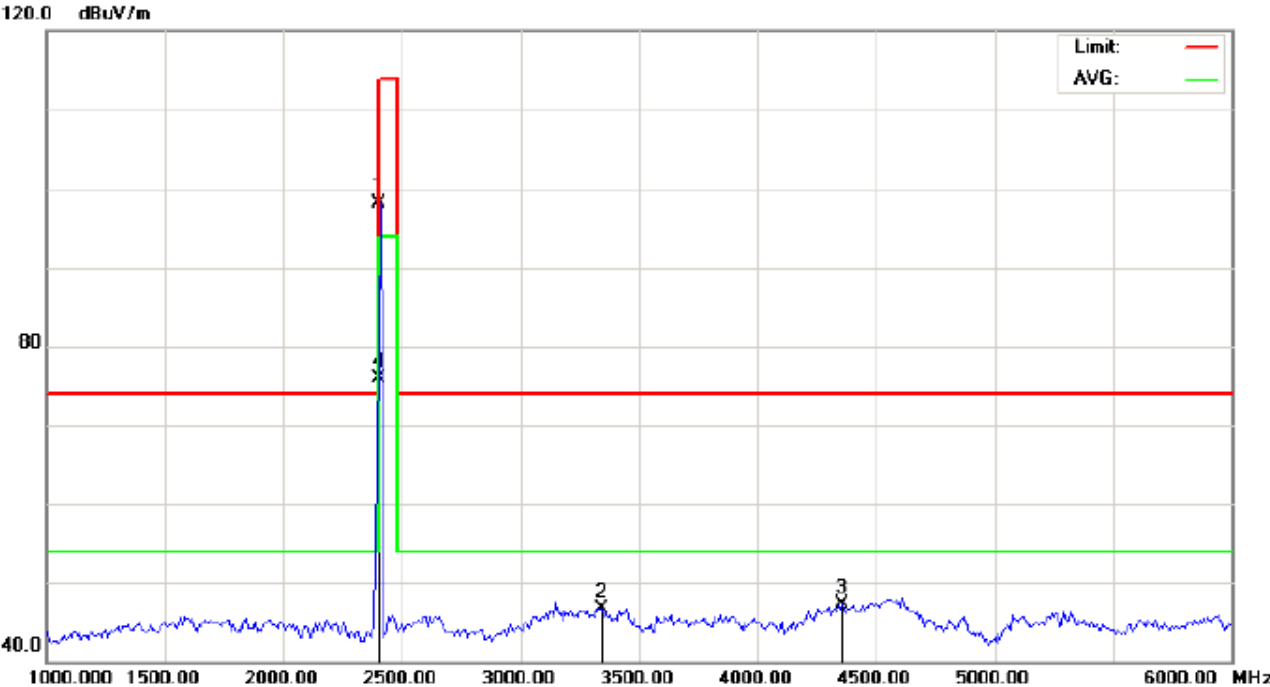

Site: site #1 Polarization: *Horizontal* Temperature: 26
 Limit: FCC Class B 3M Radiation above 1GHZ(PK) Power: Humidity: 60 %
 EUT:Bluetooth Selfie remote Distance: 3m
 M/N:A009
 Mode: Low Channel TX
 Note:

No.	Mk	Freq.	Reading	Factor	Measurement	Limit	Over	Detector	Antenna Height	Table Degree	Comment
		MHz	dBuV	dB/m	dBuV/m	dBuV/m	dB		cm	degree	
1	*	2402.000	107.73	-9.68	98.05	114.00	-15.95	peak			
2		3341.667	54.74	-8.04	46.70	74.00	-27.30	peak			
3		4358.333	50.90	-3.59	47.31	74.00	-26.69	peak			
4		2402.000	85.67	-9.68	75.99	94.00	-18.01	AVG	150	30	

RESULT: PASS

RADIATED EMISSION TEST- (ABOVE 1GHZ)-LOW CHANNEL- VERTICAL

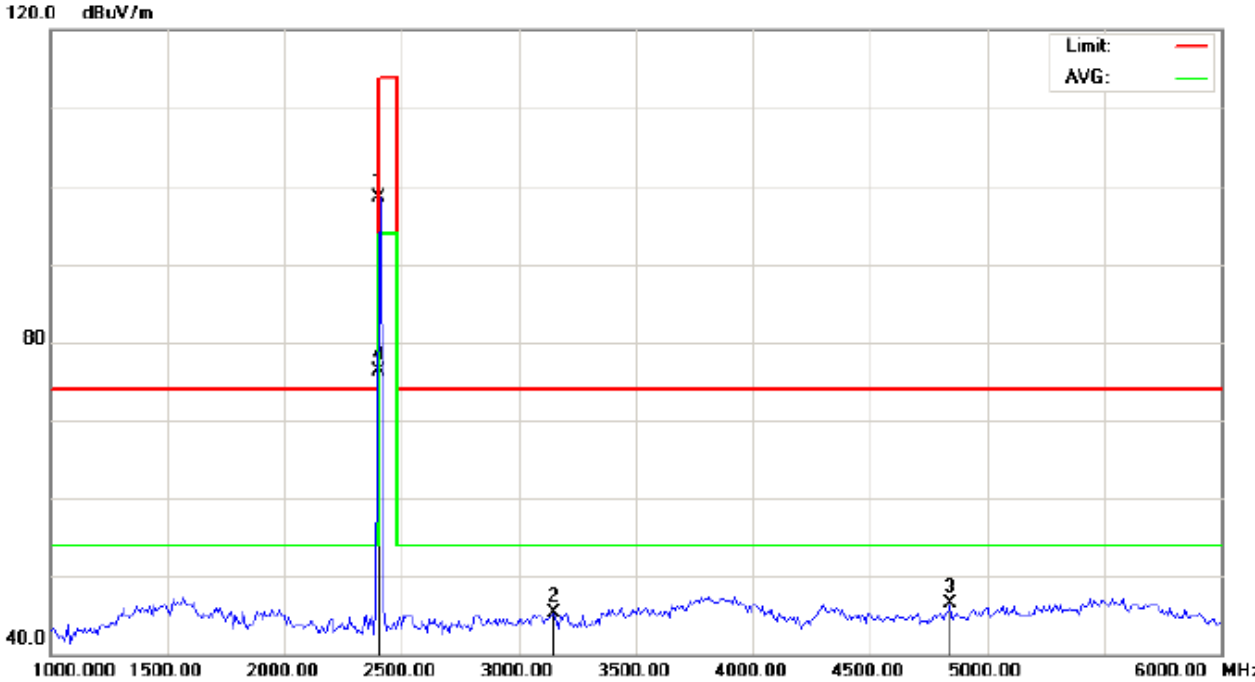

Site: site #1
 Limit: FCC Class B 3M Radiation above 1GHZ(PK)
 EUT: Bluetooth Selfie remote
 M/N: A009
 Mode: Low Channel TX
 Note:

Polarization: *Vertical*
 Power:
 Distance: 3m

Temperature: 26
 Humidity: 60 %

No.	Mk	Freq.	Reading	Factor	Measurement	Limit	Over	Detector	Antenna Height	Table Degree	Comment
		MHz	dBuV	dB/m	dBuV/m	dBuV/m	dB		cm	degree	
1	*	2402.000	108.23	-9.68	98.55	114.00	-15.45	peak			
2		3150.000	53.54	-8.22	45.32	74.00	-28.68	peak			
3		4841.667	48.62	-2.21	46.41	74.00	-27.59	peak			
4		2402.000	85.98	-9.68	76.30	94.00	-17.70	AVG	150	34	

RESULT: PASS

RADIATED EMISSION TEST- (ABOVE 1GHZ)-MIDDLE CHANNEL-HORIZONTAL

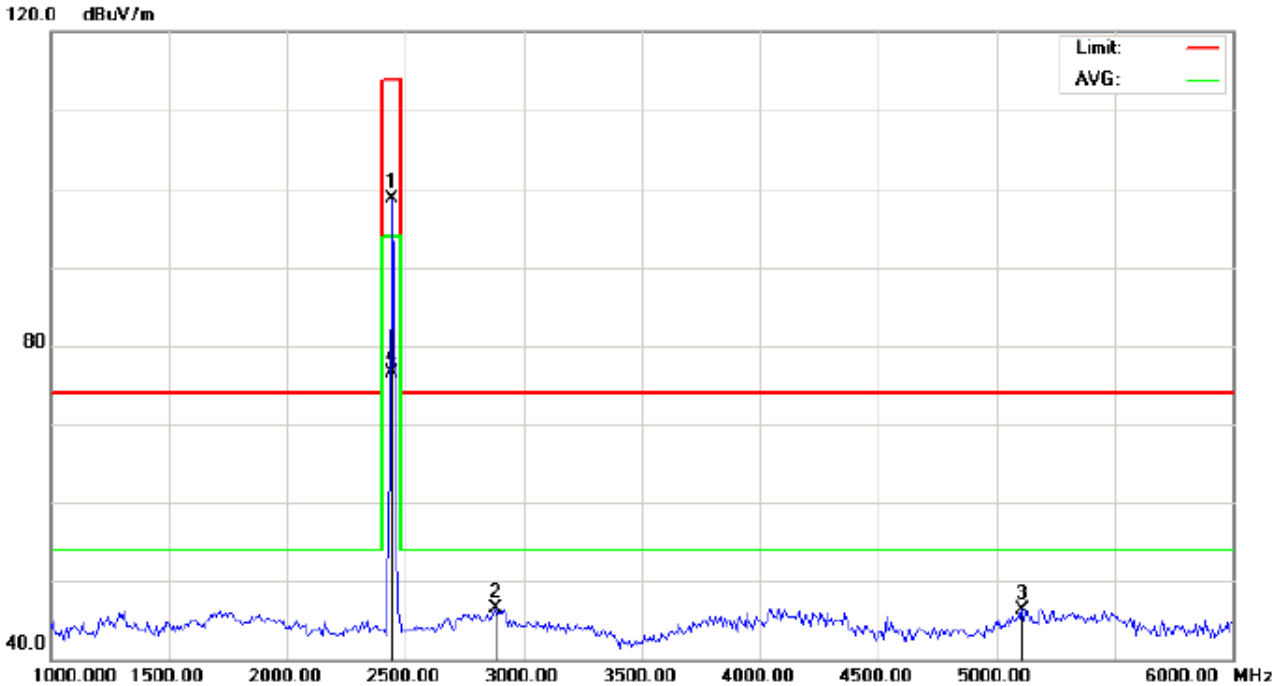

Site: site #1
 Limit: FCC Class B 3M Radiation above 1GHZ(PK)
 EUT:Bluetooth Selfie remote
 M/N:A009
 Mode: Middle Channel TX
 Note:

Polarization: *Horizontal*
 Power:
 Distance: 3m

Temperature: 26
 Humidity: 60 %

No.	Mk	Freq.	Reading	Factor	Measurement	Limit	Over	Detector	Antenna Height	Table Degree	Comment
		MHz	dBuV	dB/m	dBuV/m	dBuV/m	dB		cm	degree	
1	*	2441.000	108.29	-9.63	98.66	114.00	-15.34	peak			
2		2883.333	55.16	-8.64	46.52	74.00	-27.48	peak			
3		5108.333	48.20	-1.80	46.40	74.00	-27.60	peak			
4		2441.000	86.09	-9.63	76.46	94.00	-17.54	AVG	150	56	

RESULT: PASS

RADIATED EMISSION TEST- (ABOVE 1GHZ)-MIDDLE CHANNEL- VERTICAL

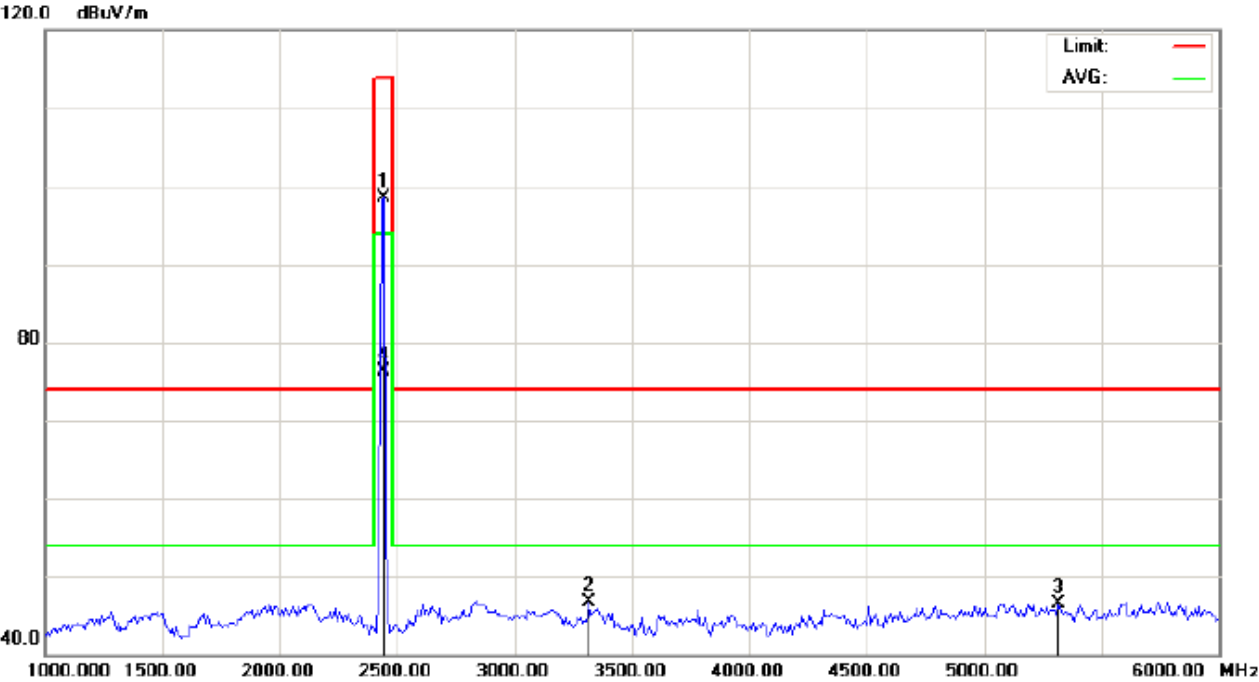

Site: site #1
 Limit: FCC Class B 3M Radiation above 1GHZ(PK)
 EUT:Bluetooth Selfie remote
 M/N:A009
 Mode: Middle Channel TX
 Note:

Polarization: *Vertical*
 Power:
 Distance: 3m

Temperature: 26
 Humidity: 60 %

No.	Mk	Freq.	Reading	Factor	Measurement	Limit	Over	Detector	Antenna Height	Table Degree	Comment
		MHz	dBuV	dB/m	dBuV/m	dBuV/m	dB		cm	degree	
1	*	2441.000	108.23	-9.63	98.60	114.00	-15.40	peak			
2		3316.667	54.69	-8.06	46.63	74.00	-27.37	peak			
3		5316.667	48.39	-1.81	46.58	74.00	-27.42	peak			
4		2441.000	86.01	-9.63	76.38	94.00	-17.62	AVG	150	50	

RESULT: PASS

RADIATED EMISSION TEST- (ABOVE 1GHZ)-HIGH CHANNEL-HORIZONTAL

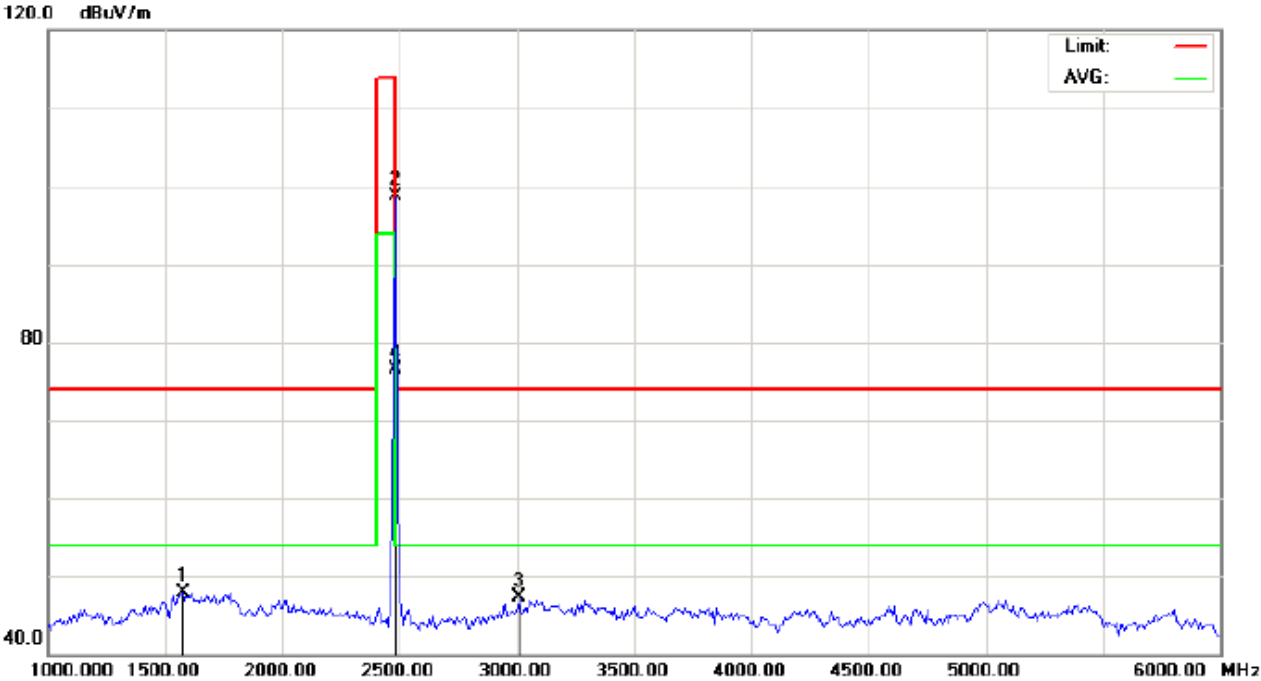

Site: site #1 Polarization: *Horizontal* Temperature: 26
 Limit: FCC Class B 3M Radiation above 1GHZ(PK) Power: Humidity: 60 %
 EUT:Bluetooth Selfie remote Distance: 3m
 M/N:A009
 Mode: High Channel TX
 Note:

No.	Mk	Freq.	Reading	Factor	Measurement	Limit	Over	Detector	Antenna Height	Table Degree	Comment
		MHz	dBuV	dB/m	dBuV/m	dBuV/m	dB		cm	degree	
1		1575.000	62.57	-14.59	47.98	74.00	-26.02	peak			
2	*	2480.000	108.37	-9.59	98.78	114.00	-15.22	peak			
3		3008.333	55.65	-8.35	47.30	74.00	-26.70	peak			
4		2480.000	86.15	-9.59	76.56	94.00	-17.44	AVG	100	67	

RESULT: PASS

RADIATED EMISSION TEST- (ABOVE 1GHZ)-HIGH CHANNEL- VERTICAL

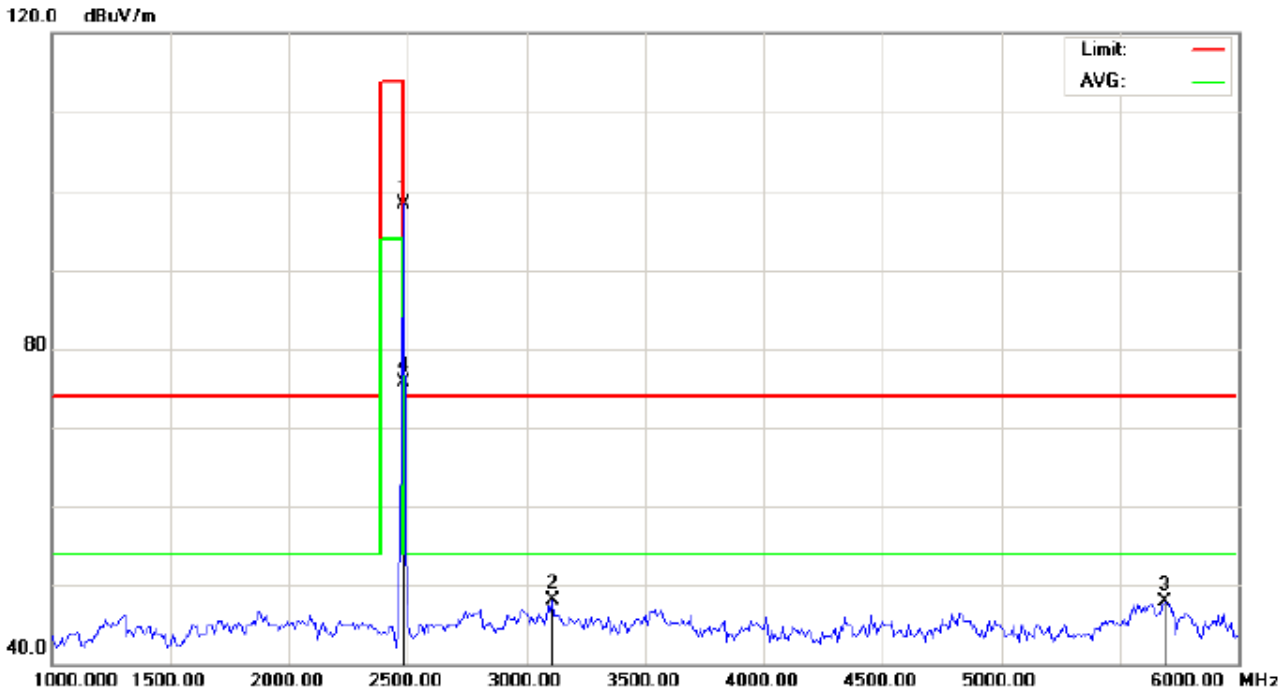

Site: site #1
 Limit: FCC Class B 3M Radiation above 1GHZ(PK)
 EUT:Bluetooth Selfie remote
 M/N:A009
 Mode: High Channel TX
 Note:

Polarization: *Vertical*
 Power:
 Distance: 3m

Temperature: 26
 Humidity: 60 %

No.	Mk	Freq.	Reading	Factor	Measurement	Limit	Over	Detector	Antenna Height	Table Degree	Comment
		MHz	dBuV	dB/m	dBuV/m	dBuV/m	dB		cm	degree	
1	*	2480.000	107.87	-9.59	98.28	114.00	-15.72	peak			
2		3108.333	56.37	-8.26	48.11	74.00	-25.89	peak			
3		5691.667	49.55	-1.72	47.83	74.00	-26.17	peak			
4		2480.000	85.26	-9.59	75.67	94.00	-18.33	AVG	100	53	

RESULT: PASS

Note: 6~25GHz at least have 20dB margin. No recording in the test report.
 Factor=Antenna Factor + Cable loss - Amplifier gain, Margin=Measurement-Limit.
 The "Factor" value can be calculated automatically by software of measurement system.

Field strength of the fundamental signal**Peak value**

Frequency	Reading Level	Factor	Measurement	Limit	Over	Antenna
(MHz)	(dBuv)	(dB/m)	(dBuv/m)	(dBuv/m)	(dB)	Polarization
2402	107.73	-9.68	98.05	114	-15.95	Horizontal
2402	108.23	-9.68	98.55	114	-15.45	Vertical
2441	108.29	-9.63	98.66	114	-15.34	Horizontal
2441	108.23	-9.63	98.60	114	-15.40	Vertical
2480	108.37	-9.59	98.78	114	-15.22	Horizontal
2480	107.87	-9.59	98.28	114	-15.72	Vertical

Average value

Frequency	Reading Level	Factor	Measurement	Limit	Over	Antenna
(MHz)	(dBuv)	(dB/m)	(dBuv/m)	(dBuv/m)	(dB)	Polarization
2402	85.67	-9.68	75.99	94	-18.01	Horizontal
2402	85.98	-9.68	76.30	94	-17.70	Vertical
2441	86.09	-9.63	76.46	94	-17.54	Horizontal
2441	86.01	-9.63	76.38	94	-17.62	Vertical
2480	86.15	-9.59	76.65	94	-17.44	Horizontal
2480	85.26	-9.59	75.67	94	-18.33	Vertical

9. BAND EDGE EMISSION

9.1. MEASUREMENT PROCEDURE

1The EUT operates at hopping-off test mode. The lowest or highest channels are tested to verify the largest transmission and spurious emissions power at the continuous transmission mode.

2Max hold the trace of the setp 1,and the EUT operates at hopping-on test mode to verify the largest spurious emissions power.

3Set the spectrum analyzer in the following setting in order to capture the lower and upper band-edges of the emission: (a) PEAK: RBW=VBW=1MHz / Sweep=AUTO

(b) AVERAGE: RBW=1MHz ; VBW=1/on time(1KHz) / Sweep=AUTO

9.2 TEST SETUP

RADIATED EMISSION TEST SETUP

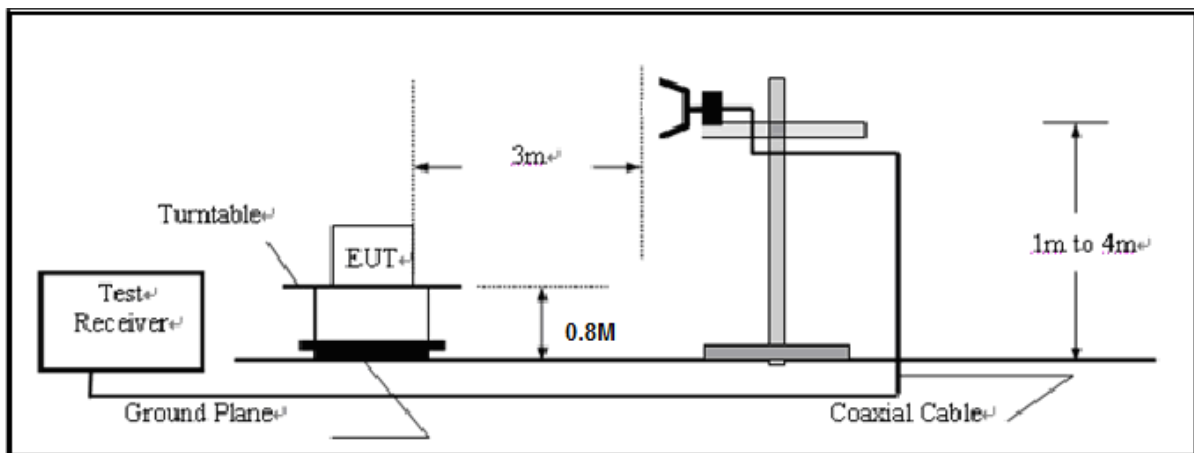

CONDUCTED TEST SETUP

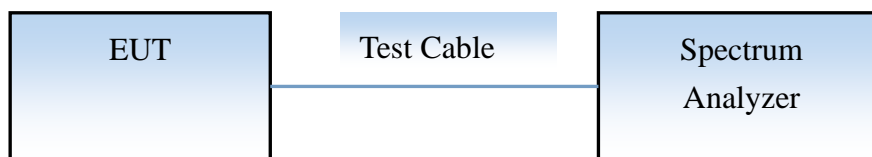

9.3 RADIATED TEST RESULT(Worst modulation:GFSK)

TEST PLOT OF BAND EDGE FOR LOW CHANNEL-Horizontal

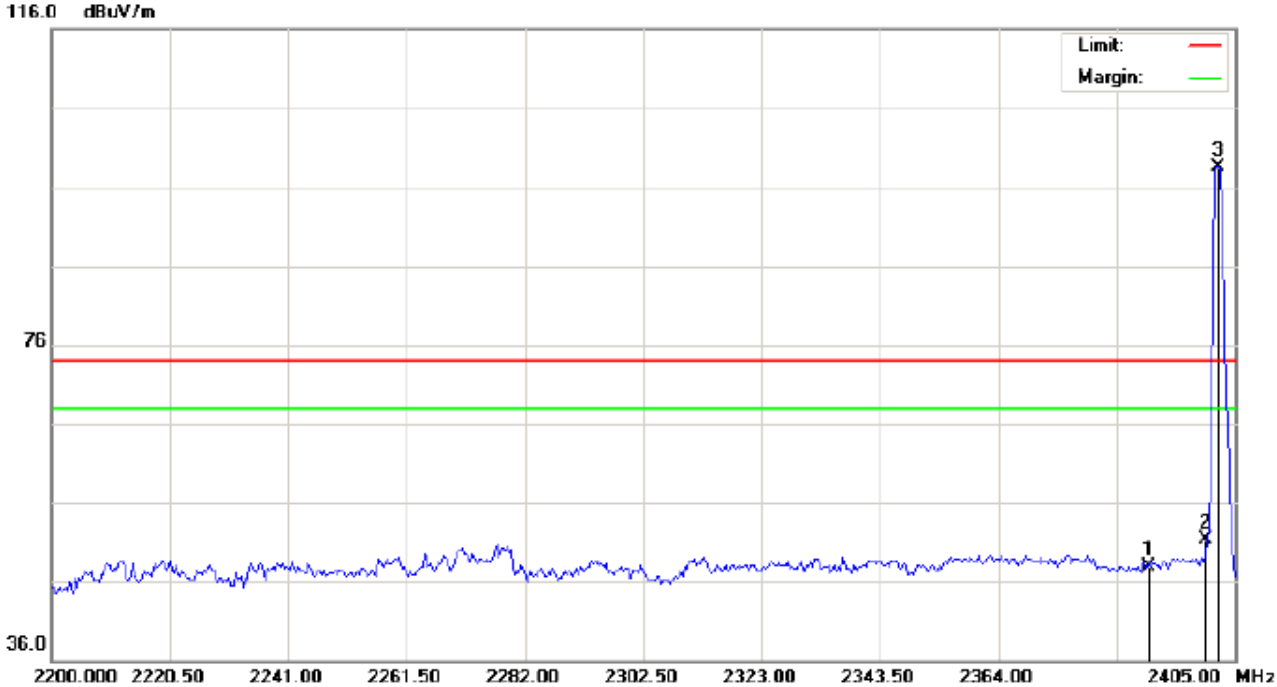

Site: site #1
Polarization: *Horizontal*
Temperature: 26
Limit: FCC Class B 3M Radiation above 1GHZ(PK)
Power:
Humidity: 60 %
EUT:Bluetooth Selfie remote
Distance:
M/N:A009
Mode: Low Channel TX
Note:

No.	Mk	Freq.	Reading	Factor	Measurement	Limit	Over	Detector	Antenna Height	Table Degree	Comment
		MHz	dBuV	dB/m	dBuV/m	dBuV/m	dB		cm	degree	
1		2390.000	37.50	10.31	47.81	74.00	-26.19	peak			
2		2400.000	40.97	10.32	51.29	74.00	-22.71	peak			
3	*	2402.000	88.22	10.32	98.54	74.00	24.54	peak			

TEST PLOT OF BAND EDGE FOR LOW CHANNEL -Vertical

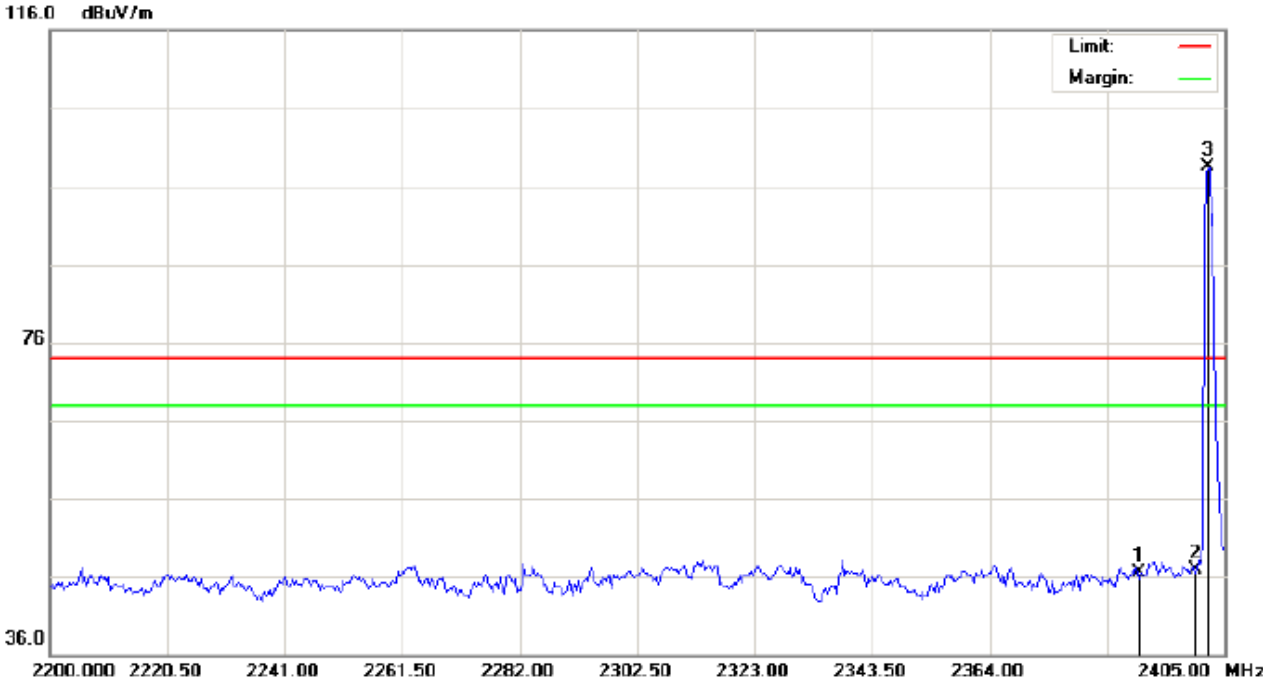

Site: site #1
 Limit: FCC Class B 3M Radiation above 1GHZ(PK)
 EUT:Bluetooth Selfie remote
 M/N:A009
 Mode: Low Channel TX
 Note:

Polarization: *Vertical*
 Power:
 Distance:

Temperature: 26
 Humidity: 60 %

No.	Mk	Freq.	Reading	Factor	Measurement	Limit	Over	Detector	Antenna Height	Table Degree	Comment
		MHz	dBuV	dB/m	dBuV/m	dBuV/m	dB		cm	degree	
1		2390.000	36.21	10.31	46.52	74.00	-27.48	peak			
2		2400.000	36.56	10.32	46.88	74.00	-27.12	peak			
3	*	2402.000	88.09	10.32	98.41	74.00	24.41	peak			

TEST PLOT OF BAND EDGE FOR HIGH CHANNEL -Horizontal

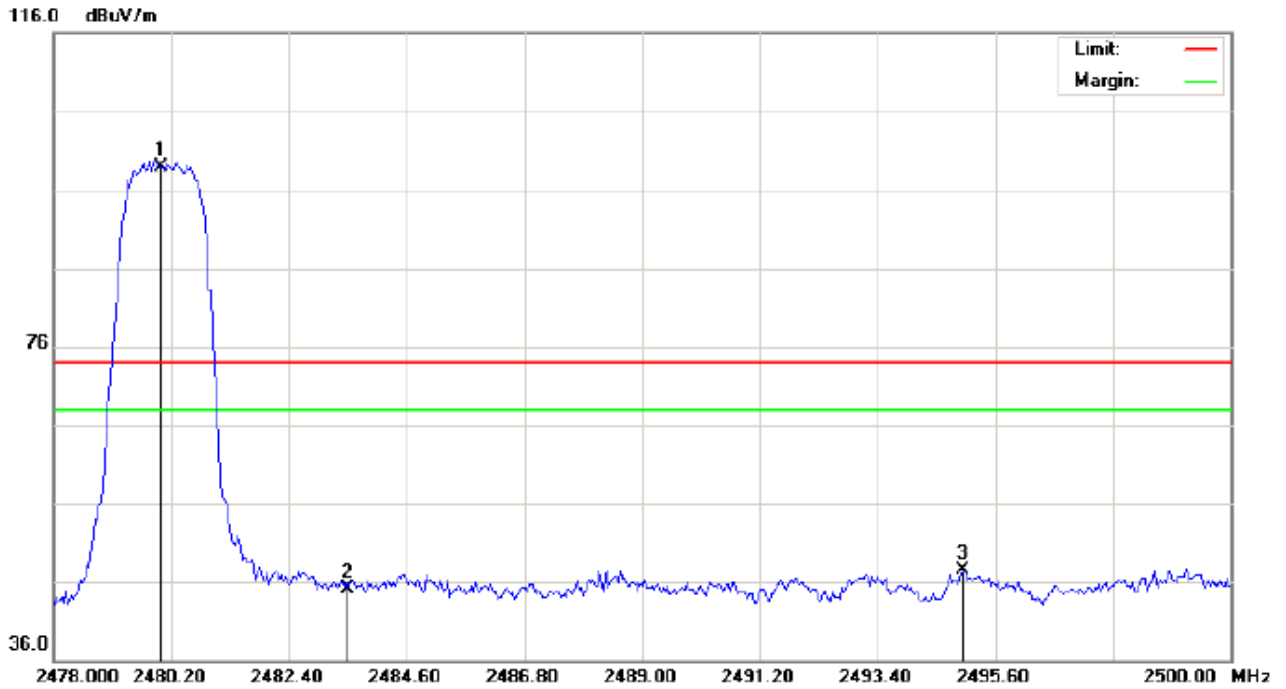

Site: site #1 Polarization: *Horizontal* Temperature: 26
Limit: FCC Class B 3M Radiation above 1GHZ(PK) Power: Humidity: 60 %
EUT:Bluetooth Selfie remote Distance:
M/N:A009
Mode: High Channel TX
Note:

No.	Mk	Freq.	Reading	Factor	Measurement	Limit	Over	Detector	Antenna Height	Table Degree	Comment
		MHz	dBuV	dB/m	dBuV/m	dBuV/m	dB		cm	degree	
1	*	2480.000	88.55	10.41	98.96	74.00	24.96	peak			
2		2483.500	34.69	10.41	45.10	74.00	-28.90	peak			
3		2495.013	37.03	10.42	47.45	74.00	-26.55	peak			

TEST PLOT OF BAND EDGE FOR HIGH CHANNEL-Vertical

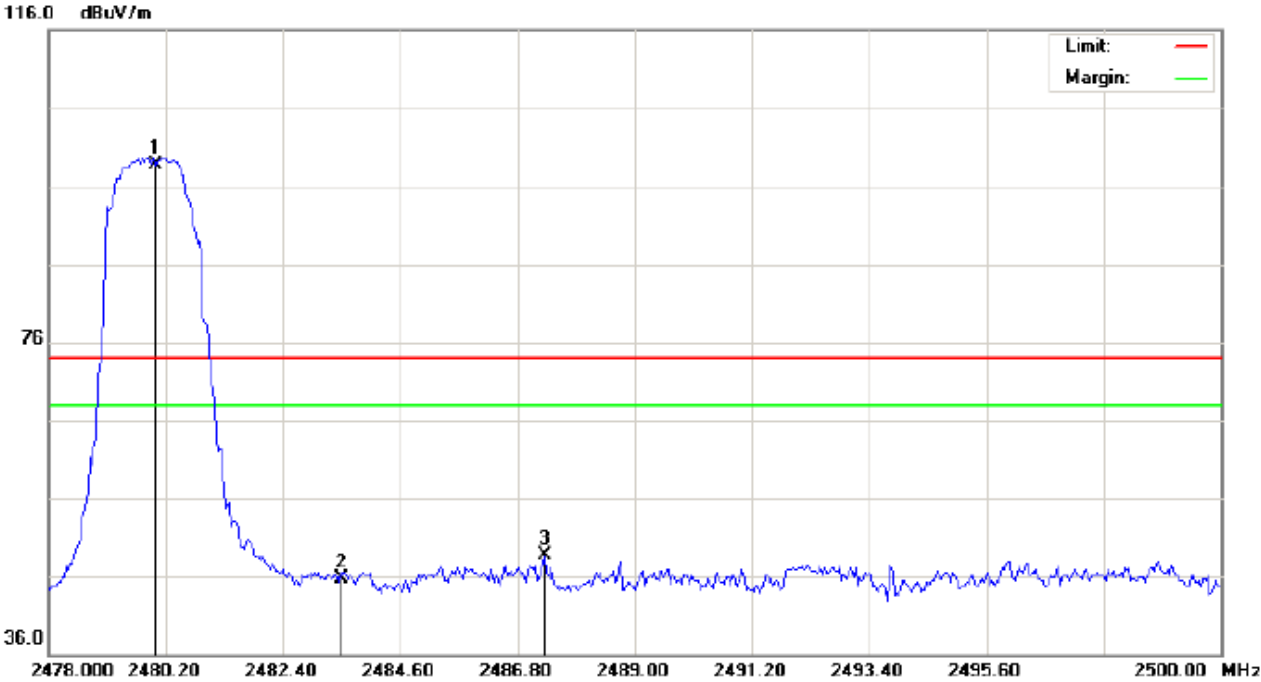

Site: site #1 Polarization: *Vertical* Temperature: 26
 Limit: FCC Class B 3M Radiation above 1GHZ(PK) Power: Humidity: 60 %
 EUT:Bluetooth Selfie remote Distance:
 M/N:A009
 Mode: High Channel TX
 Note:

No.	Mk	Freq.	Reading	Factor	Measurement	Limit	Over	Detector	Antenna	Table	Comment
		MHz	dBuV	dB/m	dBuV/m	dBuV/m	dB		Height	Degree	
									cm	degree	
1	*	2480.000	88.32	10.41	98.73	74.00	24.73	peak			
2		2483.500	35.26	10.41	45.67	74.00	-28.33	peak			
3		2487.313	38.22	10.42	48.64	74.00	-25.36	peak			

RESULT: PASS

Note: The other modes radiation emission have enough 20dB margin.
 Factor=Antenna Factor + Cable loss - Amplifier gain, Over=Measure-Limit.
 The "Factor" value can be calculated automatically by software of measurement system.

10. FCC LINE CONDUCTED EMISSION TEST

10.1. LIMITS OF LINE CONDUCTED EMISSION TEST

Frequency	Maximum RF Line Voltage	
	Q.P.(dBuV)	Average(dBuV)
150kHz~500kHz	66-56	56-46
500kHz~5MHz	56	46
5MHz~30MHz	60	50

Note:

1. The lower limit shall apply at the transition frequency.
2. The limit decreases linearly with the logarithm of the frequency in the range 0.15 MHz to 0.50 MHz.

10.2. BLOCK DIAGRAM OF LINE CONDUCTED EMISSION TEST

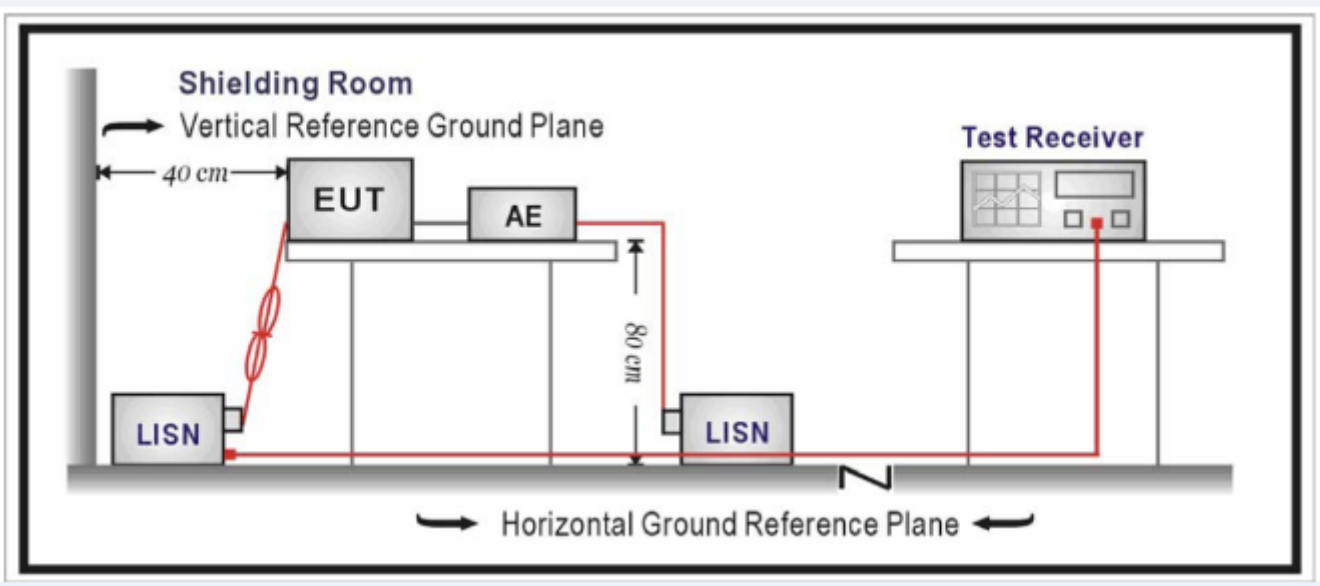

10.3. PRELIMINARY PROCEDURE OF LINE CONDUCTED EMISSION TEST

1. The equipment was set up as per the test configuration to simulate typical actual usage per the user's manual. When the EUT is a tabletop system, a wooden table with a height of 0.8 meters is used and is placed on the ground plane as per ANSI C63.4 (see Test Facility for the dimensions of the ground plane used). When the EUT is a floor-standing equipment, it is placed on the ground plane which has a 3-12 mm non-conductive covering to insulate the EUT from the ground plane.
2. Support equipment, if needed, was placed as per ANSI C63.4.
3. All I/O cables were positioned to simulate typical actual usage as per ANSI C63.4.
4. All support equipments received AC120V/60Hz power from a LISN, if any.
5. The EUT received DC charging voltage by PC which received 120V/60Hz power by a LISN..
6. The test program was started. Emissions were measured on each current carrying line of the EUT using a spectrum Analyzer / Receiver connected to the LISN powering the EUT. The LISN has two monitoring points: Line 1 (Hot Side) and Line 2 (Neutral Side). Two scans were taken: one with Line 1 connected to Analyzer / Receiver and Line 2 connected to a 50 ohm load; the second scan had Line 1 connected to a 50 ohm load and Line 2 connected to the Analyzer / Receiver.
7. Analyzer / Receiver scanned from 150 kHz to 30MHz for emissions in each of the test modes.
8. During the above scans, the emissions were maximized by cable manipulation.
9. The test mode(s) were scanned during the preliminary test.

Then, the EUT configuration and cable configuration of the above highest emission level were recorded for reference of final testing.

10.4. FINAL PROCEDURE OF LINE CONDUCTED EMISSION TEST

- EUT and support equipment was set up on the test bench as per step 2 of the preliminary test.
2. A scan was taken on both power lines, Line 1 and Line 2, recording at least the six highest emissions. Emission frequency and amplitude were recorded into a computer in which correction factors were used to calculate the emission level and compare reading to the applicable limit. If EUT emission level was less -2dB to the A.V. limit in Peak mode, then the emission signal was re-checked using Q.P and Average detector.
3. The test data of the worst case condition(s) was reported on the Summary Data page.

10.5. TEST RESULT OF LINE CONDUCTED EMISSION TEST

N/A

APPENDIX A: PHOTOGRAPHS OF TEST SETUP
FCC RADIATED EMISSION TEST SETUP

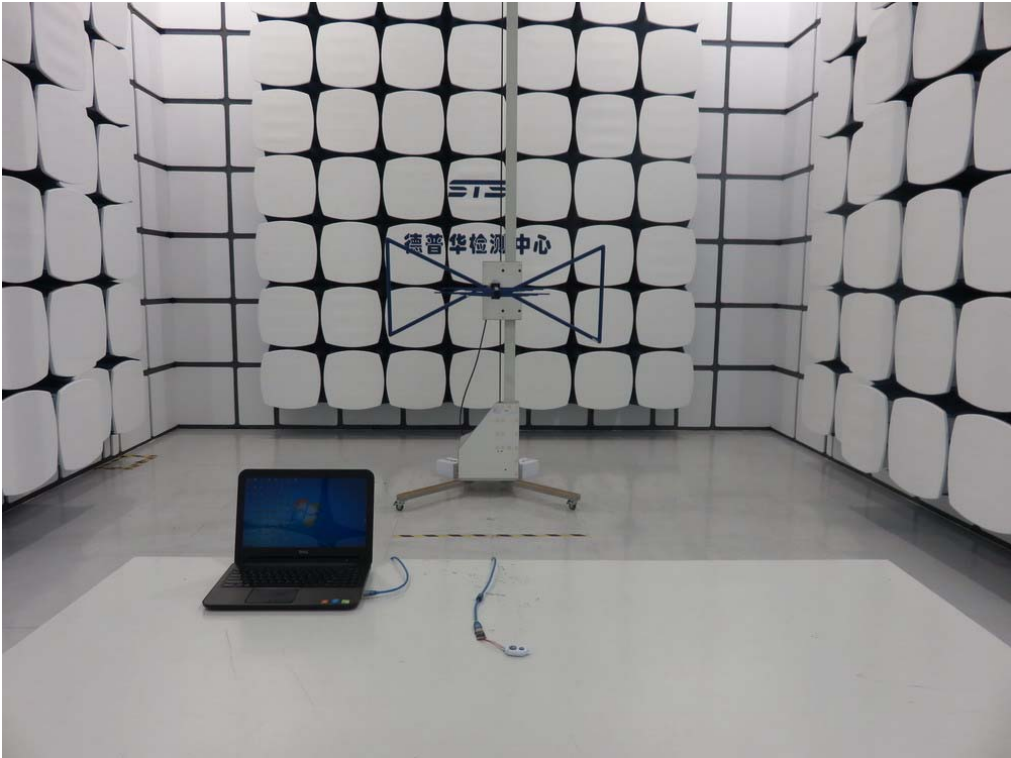
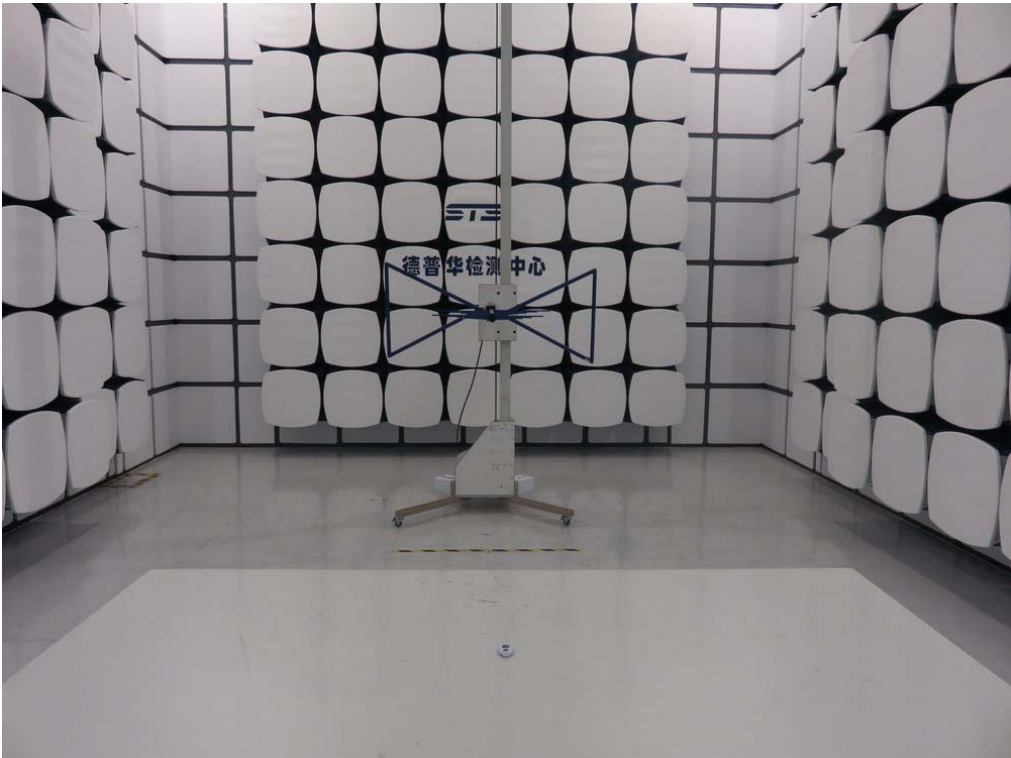

APPENDIX B: PHOTOGRAPHS OF EUT
TOP VIEW OF EUT



BOTTOM VIEW OF EUT



FRONT VIEW OF EUT



BACK VIEW OF EUT



LEFT VIEW OF EUT



RIGHT VIEW OF EUT

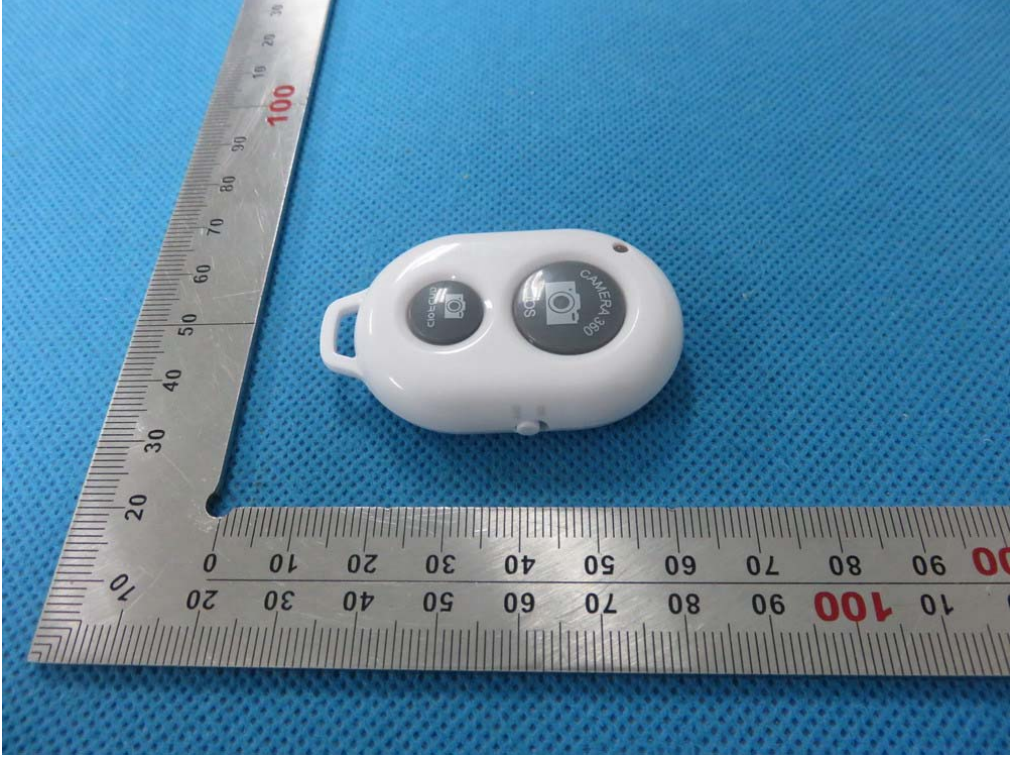

OPEN VIEW OF EUT



INTERNAL VIEW OF EUT-1

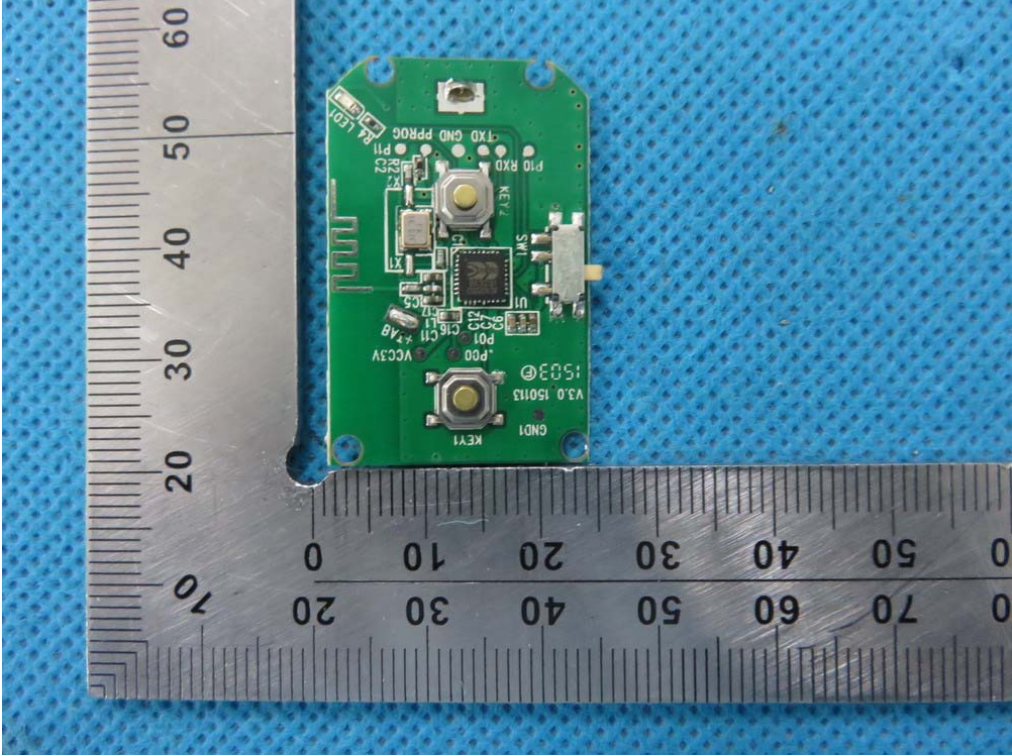

INTERNAL VIEW OF EUT-2

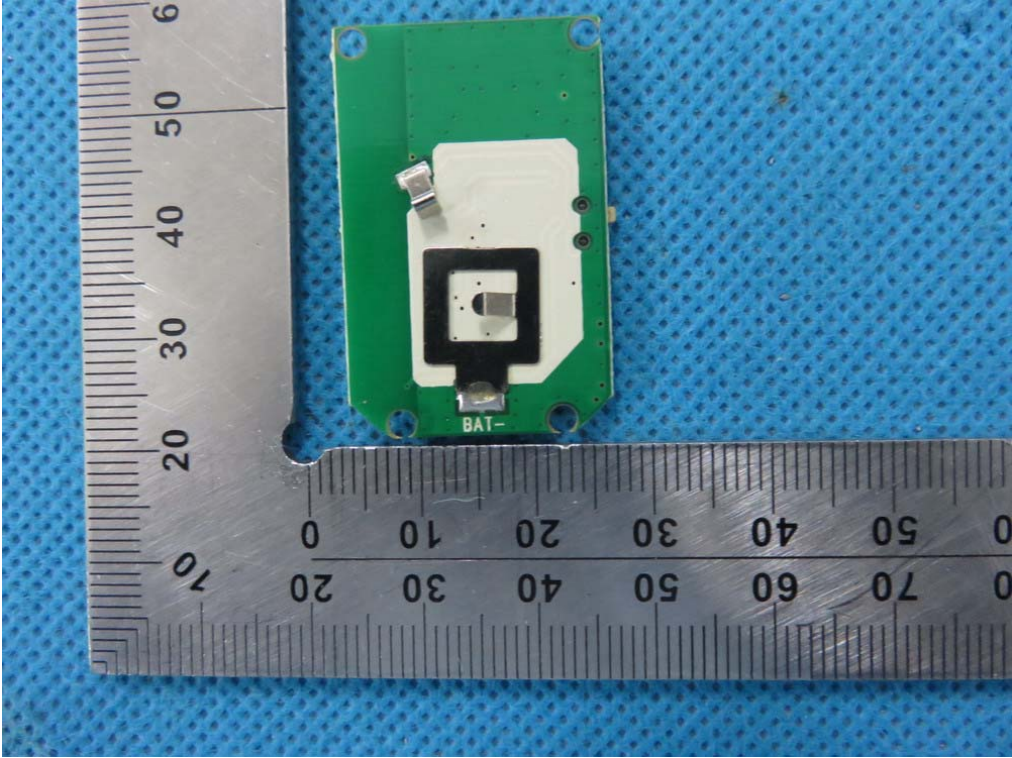

INTERNAL VIEW OF EUT-3

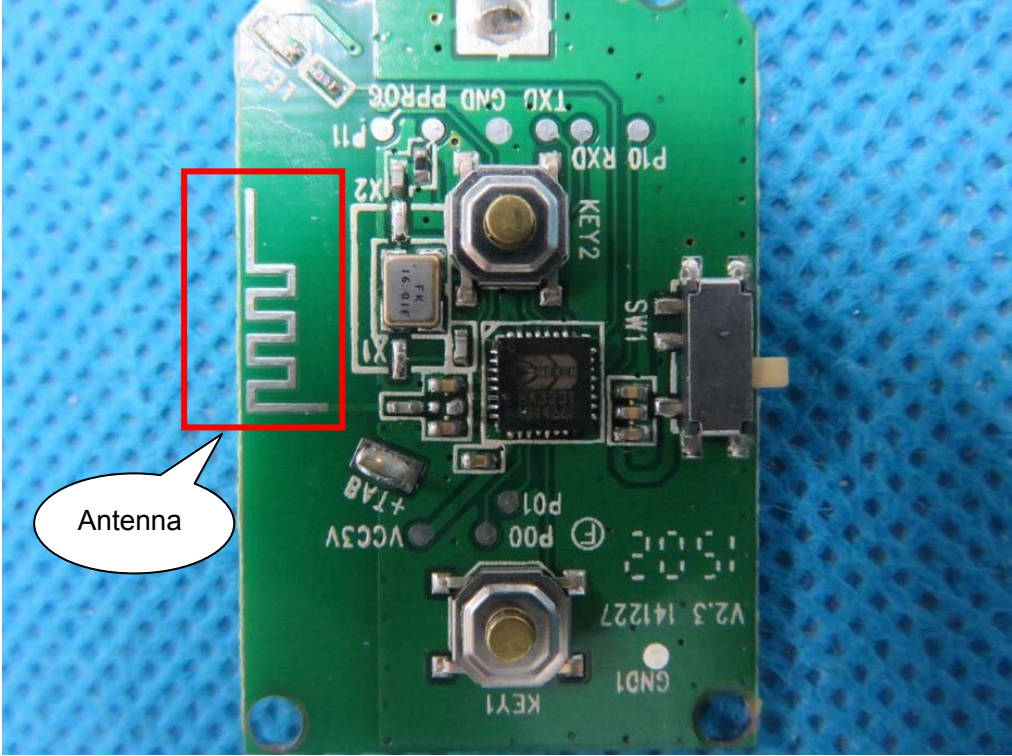

----END OF REPORT----