

Model SCAN_PEN		Sheet 10_RK3326_POWER	No 1 of 17
Board XZY_VT-E02_V1.1		BOARD NO.	Rev. V1.1
DESIGN	CHECKED	APPROVED	DATE 2020-08-21

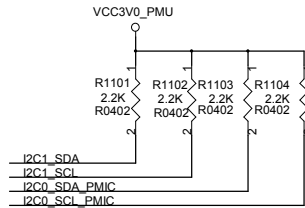

Model		SCAN_PEN	Sheet	11_RK3326_OSC/PMUIO	No	2 of 17
Board		XZY_VT-E02_V1.1	BOARD NO.		Rev.	V1.1
DESIGN	CHECKED	APPROVED	DATE	2020-08-21		

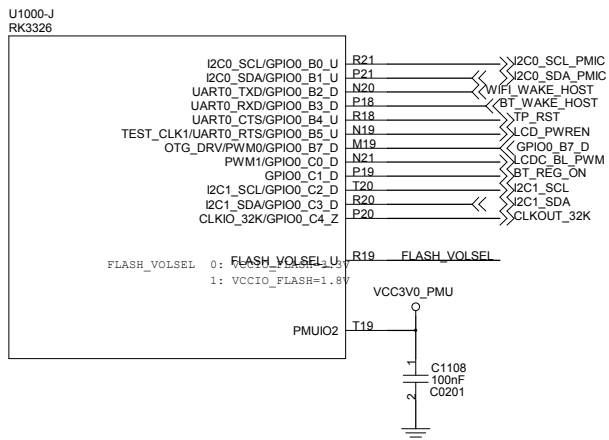
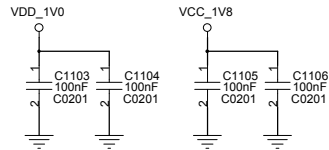
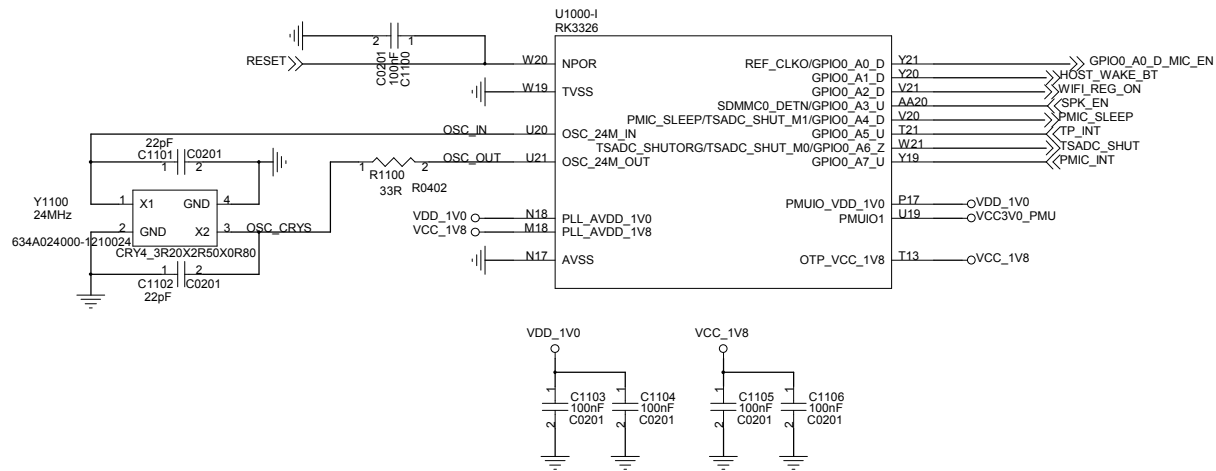
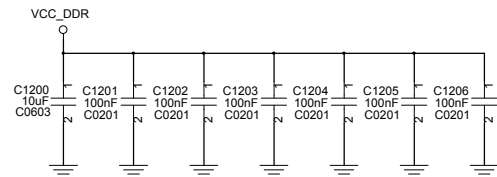
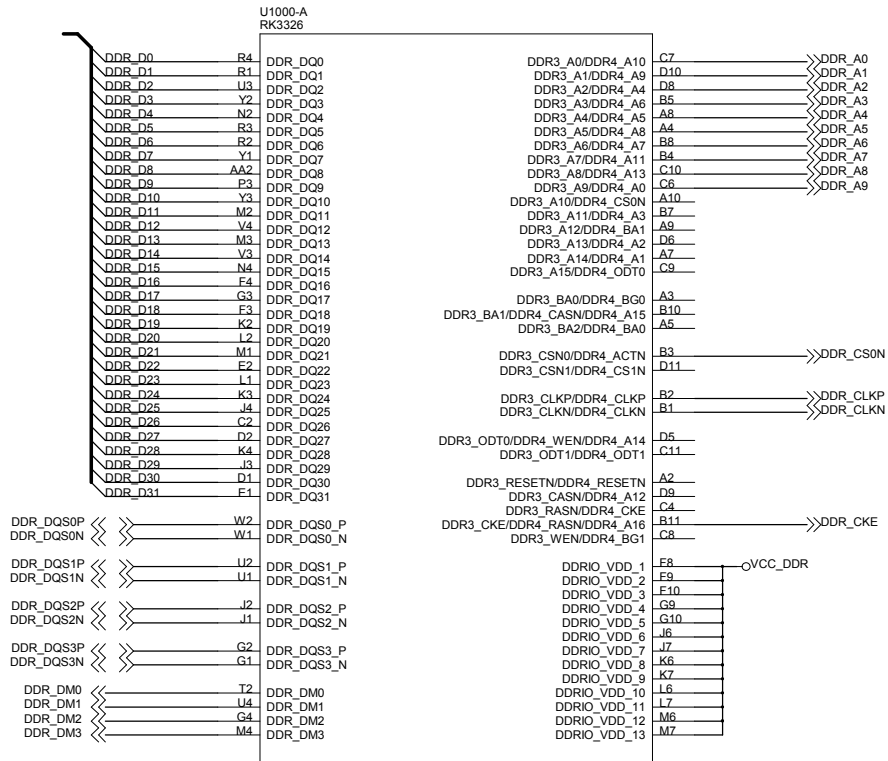

Model		SCAN_PEN	Sheet	12_RK3326_DDR_CONTROLLER	No	3 of 17
Board		XZY_VT-E02_V1.1	BOARD NO.		Rev.	V 1.1
DESIGN	CHECKED	APPROVED		DATE		
					2020-08-21	

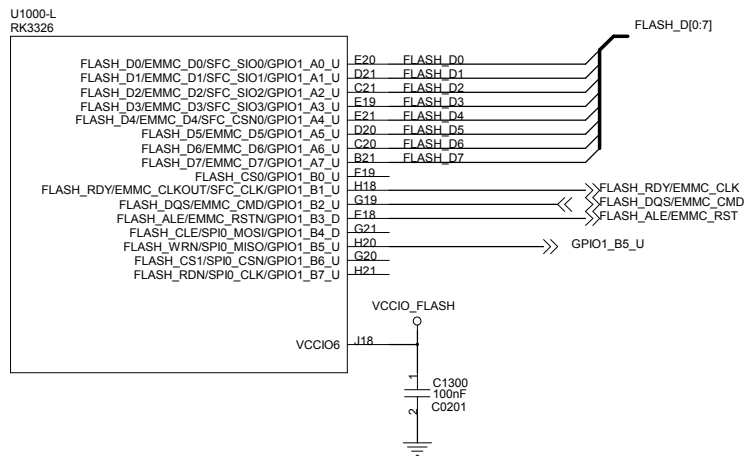

Model		Sheet		No	
SCAN_PEN		13_RK3326 FLASH CONTROLLER		4 of 17	
Board		BOARD NO.		Rev.	
XZY_VT-E02_V1.1				V1.1	
DESIGN	CHECKED	APPROVED	DATE		
			2020-08-21		

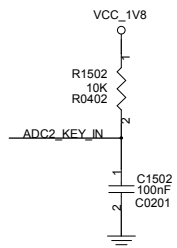
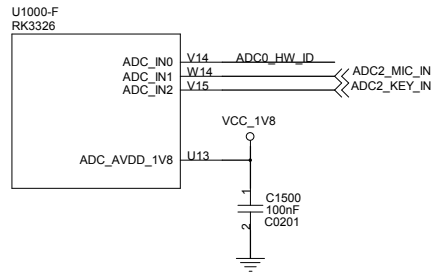

Model		Sheet		No	
SCAN_PEN		15_RK3326_SARADC		6 of 17	
Board		BOARD NO.		Rev.	
XZY_VT-E02_V1.1				V1.1	
DESIGN	CHECKED	APPROVED	DATE		
			2020-08-21		

U1000-D
RK3326

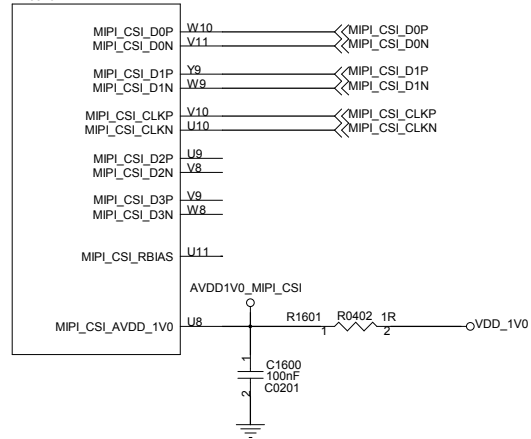

U1000-B
RK3326

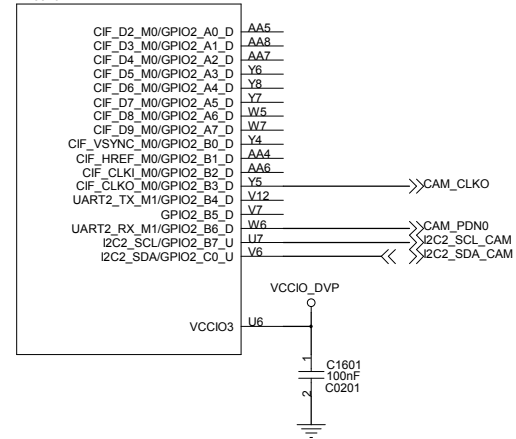

Model		Sheet		No	
SCAN_PEN		16_RK3326_DVP_INTERFACE		7 of 17	
Board		BOARD NO.		Rev.	
XZY_VT-E02_V1.1				V1.1	
DESIGN	CHECKED	APPROVED	DATE		
			2020-08-21		

RK3326 Part-M

U1000-M
RK3326

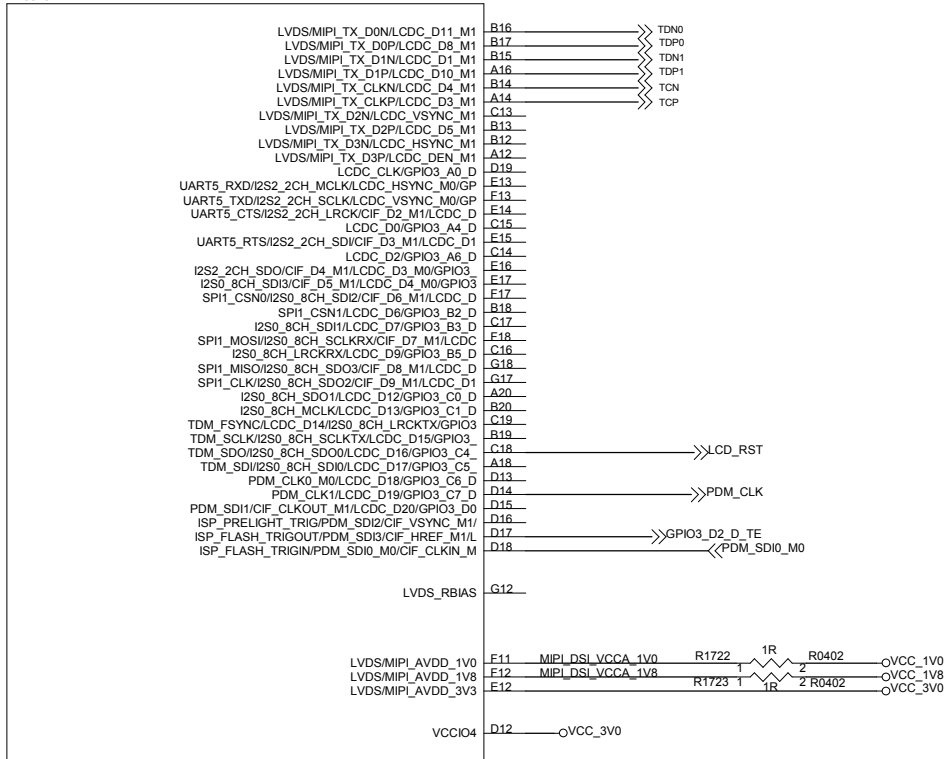

Model		Sheet	No
SCAN_PEN		17_RK3326_DISPLAY	8 of 17
Board		BOARD NO.	Rev.
XZY_VT-E02_V1.1			V1.1
DESIGN	CHECKED	APPROVED	DATE
			2020-08-21

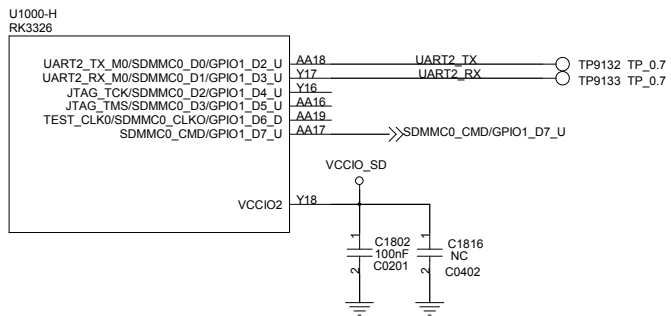
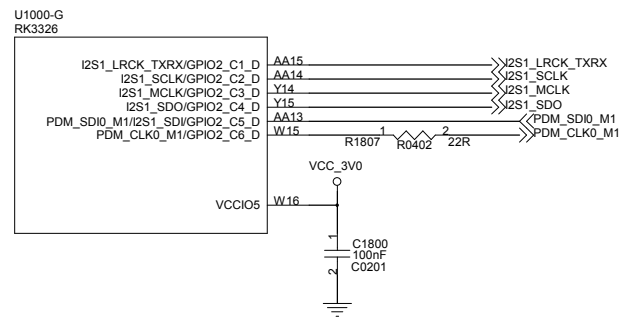
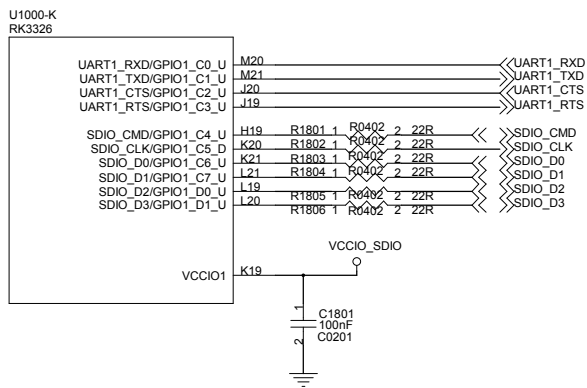

Model		Sheet		No	
SCAN_PEN		18_RK3326_UART/SDIO/I2S		9 of 17	
Board		BOARD NO.		Rev.	
XZY_VT-E02_V1.1				V1.1	
DESIGN	CHECKED	APPROVED	DATE		
			2020-08-21		

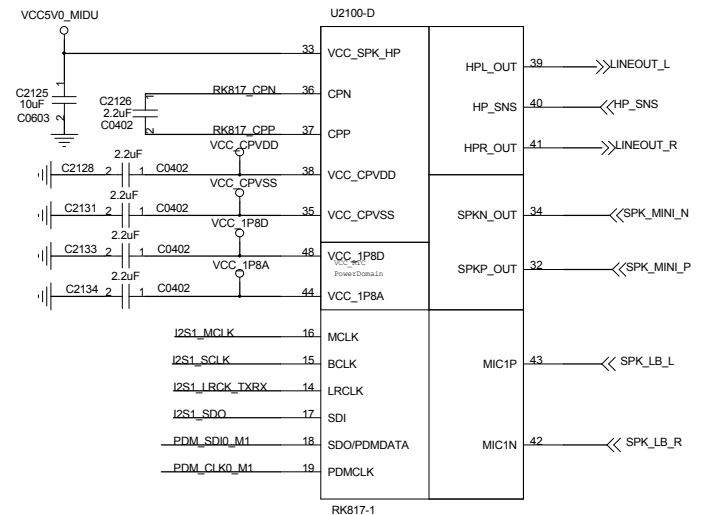
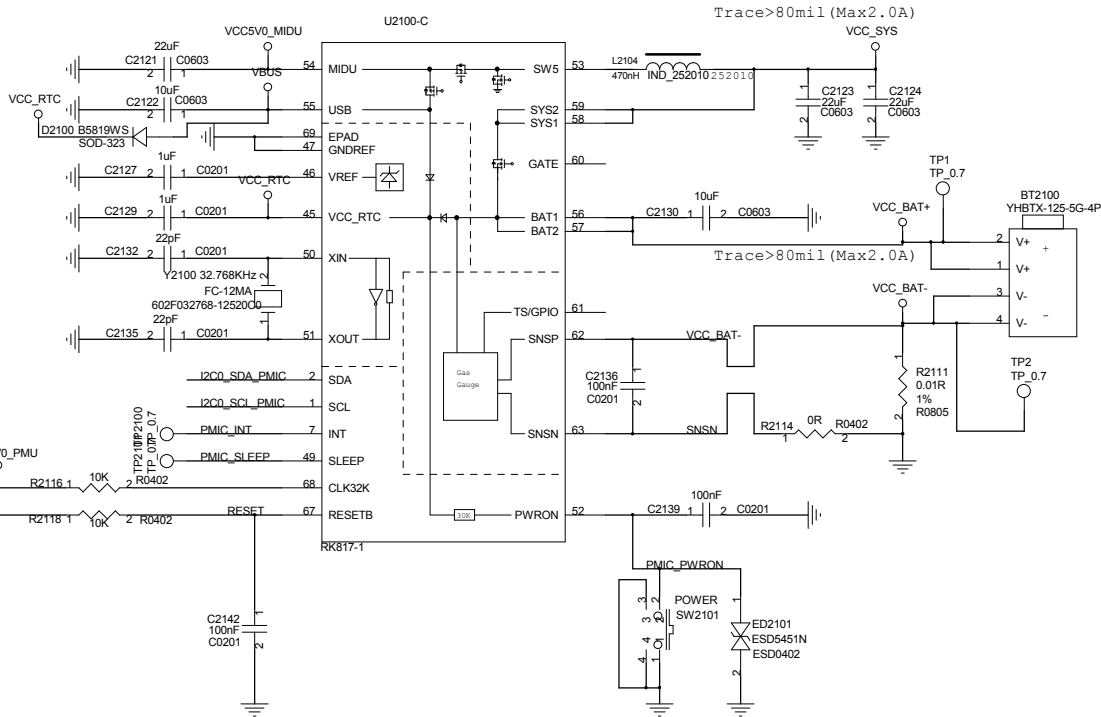
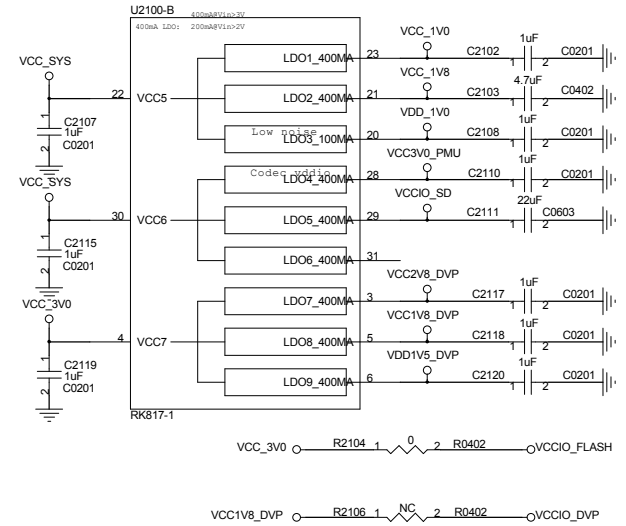
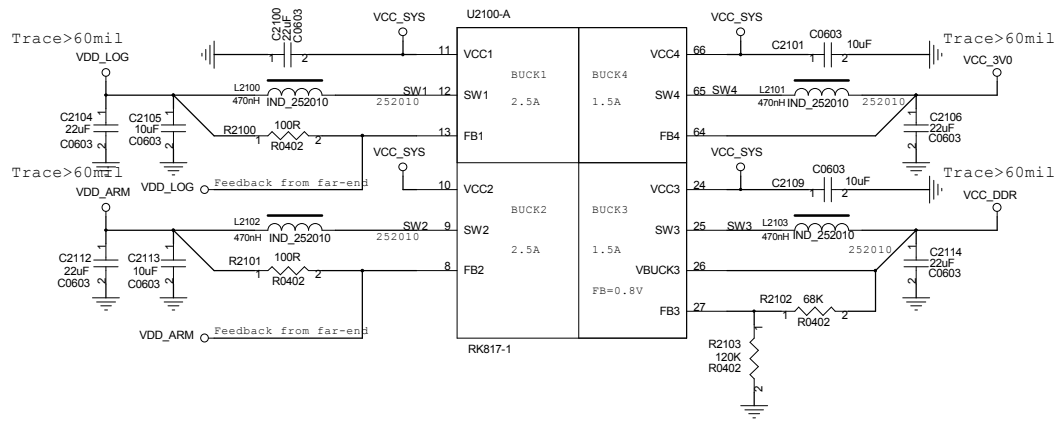

Model	SCAN_PEN	Sheet	21_POWER-PMIC_RK817-1	No	10 of 17
Board	XZY_VT-E02_V1.1	BOARD NO.		Rev.	V1.1
DESIGN	CHECKED	APPROVED		DATE	2020-08-21

USB Port

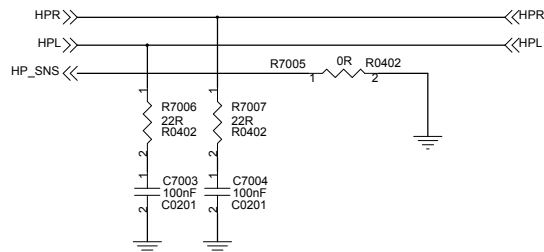
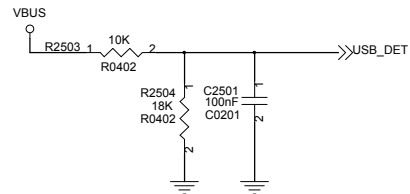
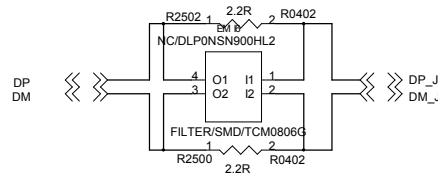
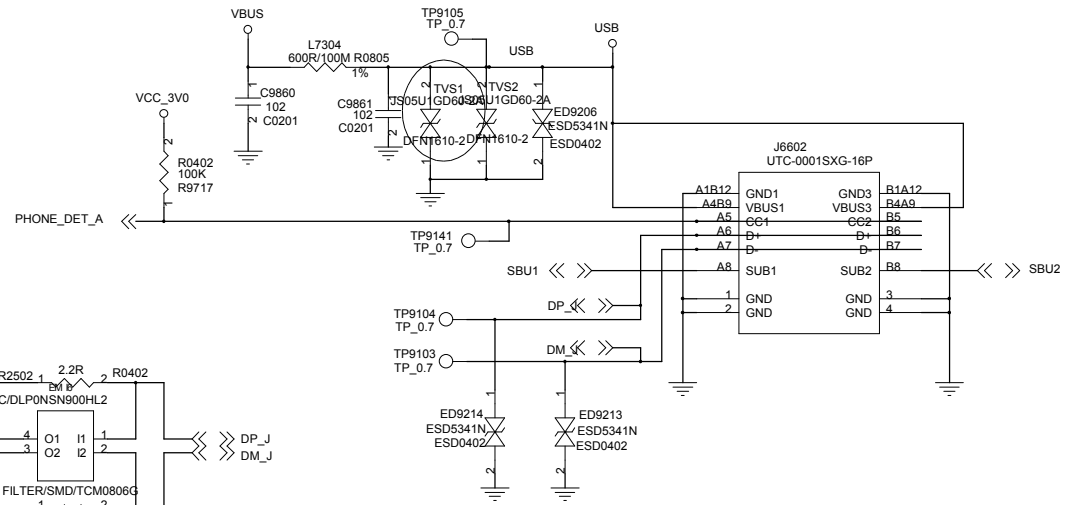
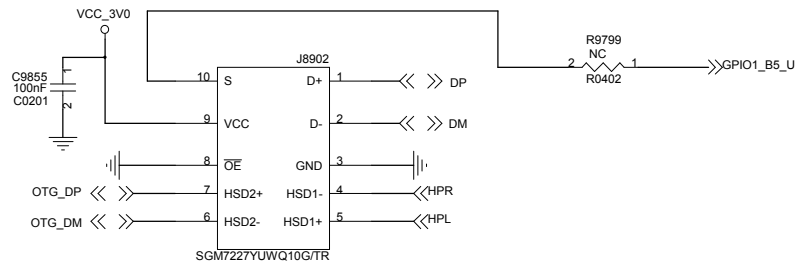

Model	SCAN_PEN	Sheet	25_USB_OTG_PORT	No	11 of 17
Board	XZY_VT-E02_V1.1	BOARD NO.		Rev.	V1.1
DESIGN	CHECKED	APPROVED	DATE	2020-08-21	

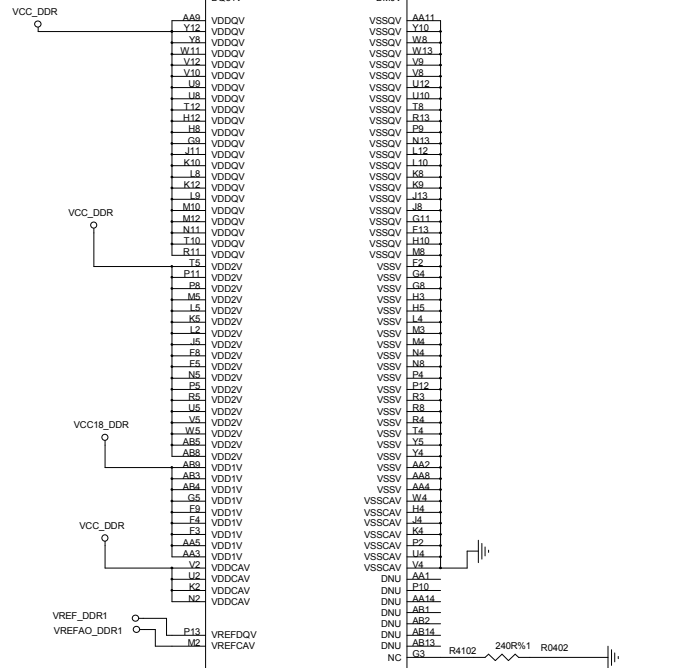
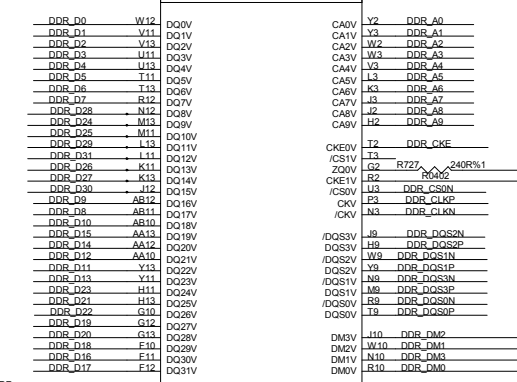
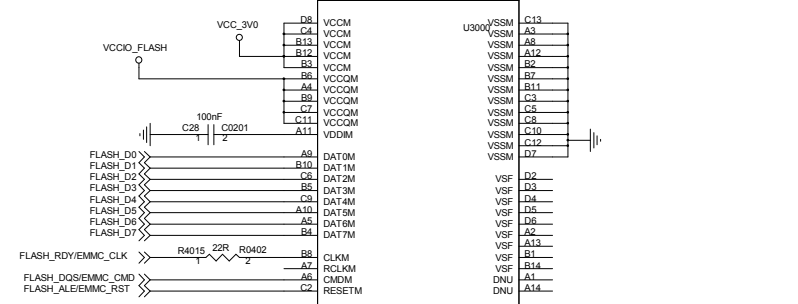
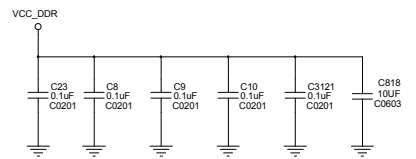
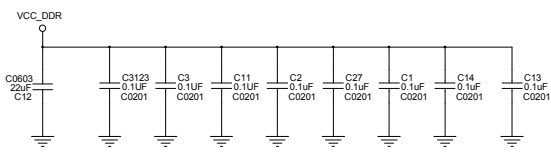
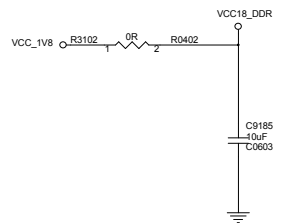

NCEPNAG1M-0808

Model	SCAN_PEN	Sheet	31_RAM-DDR1X16	No	12 of 17
Board	XZY_VT-E02_V1.1	BOARD NO.		Rev.	V1.1
DESIGN	CHECKED	APPROVED		DATE	2020-08-21

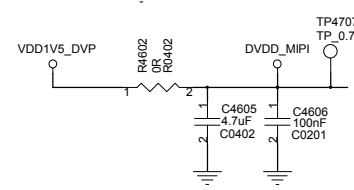
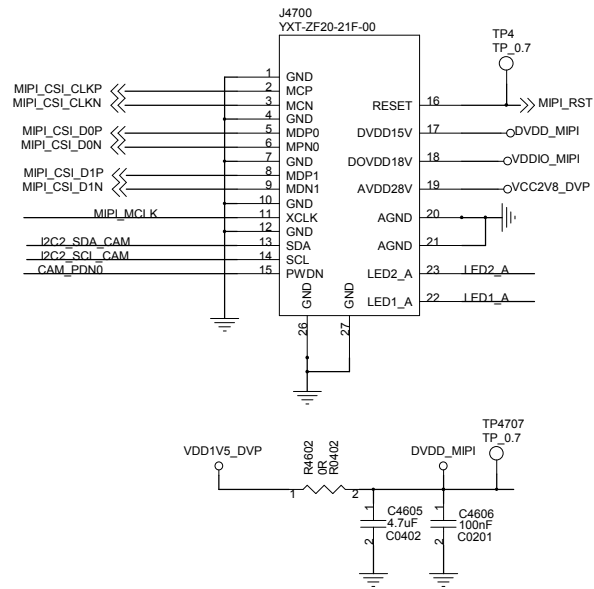
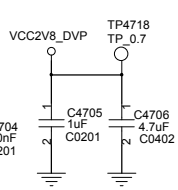
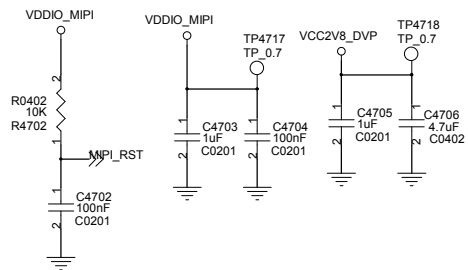
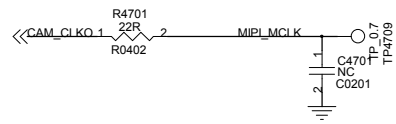

Model		Sheet		No	
SCAN_PEN		47_CAMERA-MIPI		13 of 17	
Board		BOARD NO.		Rev.	
XZY_VT-E02_V1.1				V1.1	
DESIGN	CHECKED	APPROVED	DATE		
			2020-08-21		

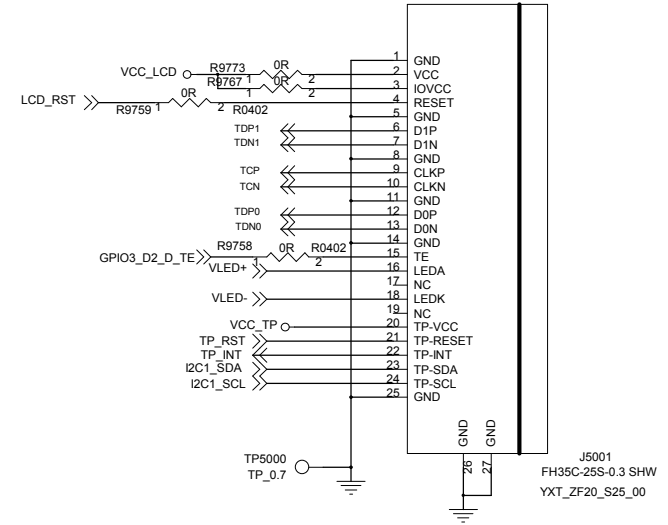
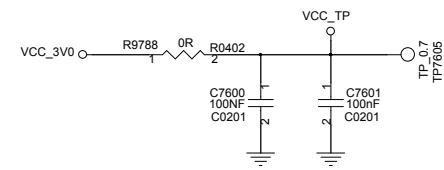
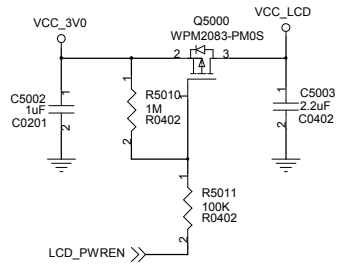
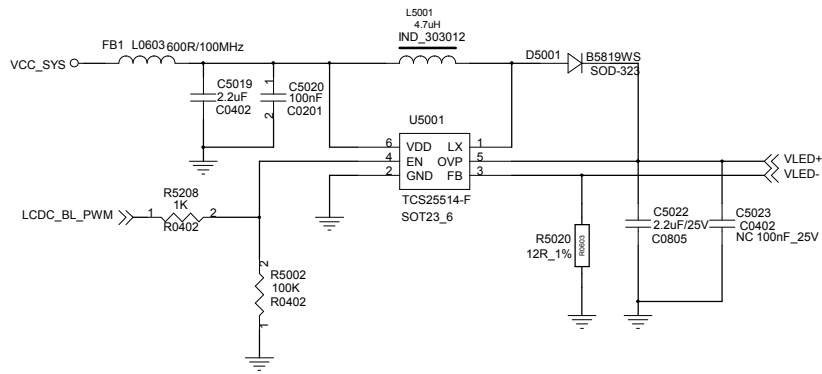

Model	SCAN_PEN	Sheet	50_LCM-MIPI_2LINE	No	14 of 17
Board	XZY_VT-E02_V1.1	BOARD NO.		Rev.	V1.1
DESIGN	CHECKED	APPROVED	DATE	2020-08-21	

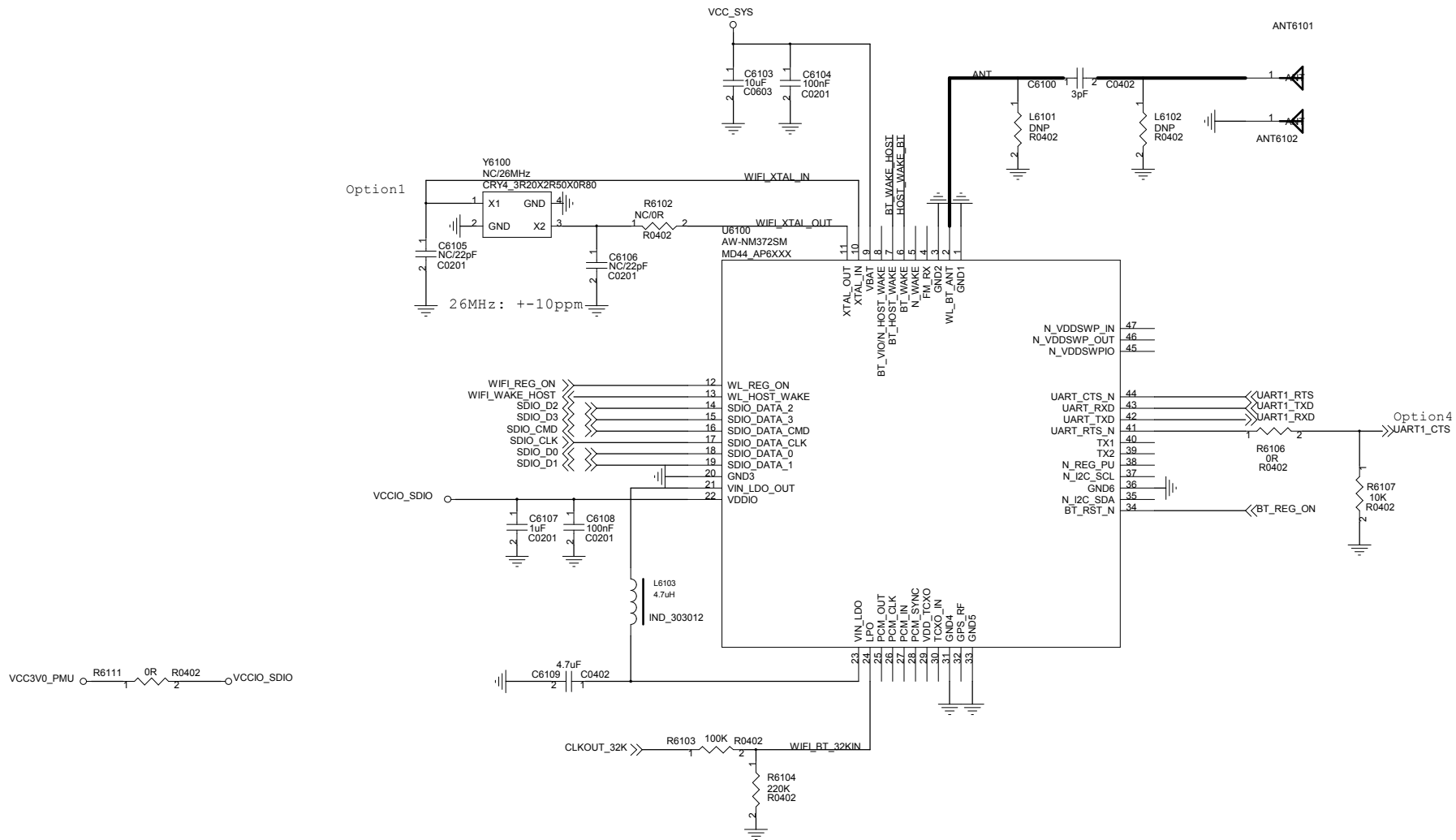

Model	SCAN_PEN	Sheet	61_SDIO_WIFI/BT-1T1R	No	15 of 17
Board	XZY_VT-E02_V1.1	BOARD NO.		Rev.	V1.1
DESIGN	CHECKED	APPROVED		DATE	2020-08-21

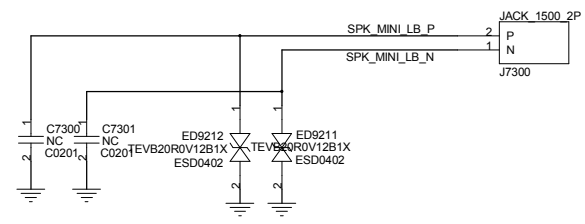
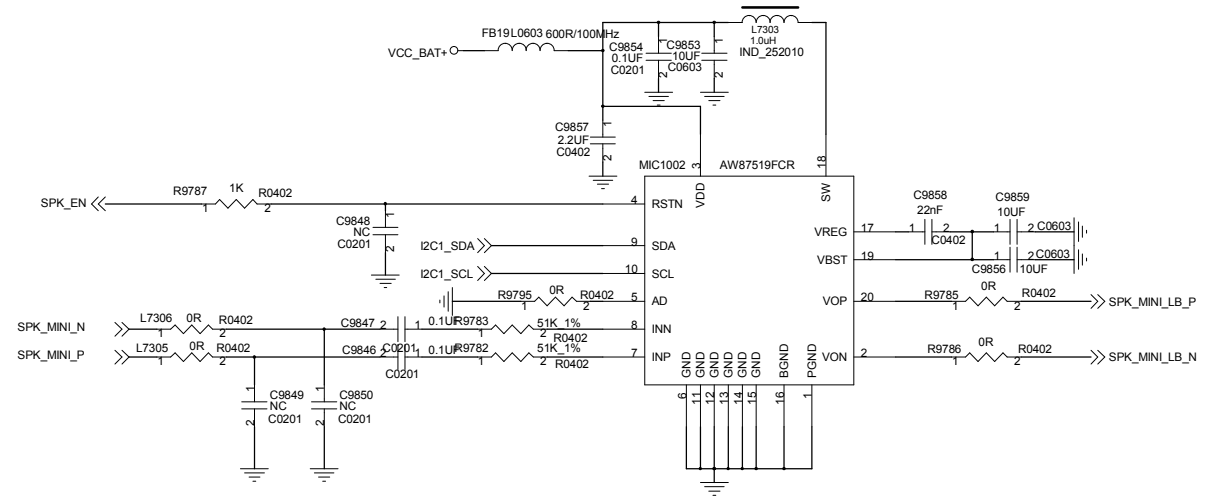
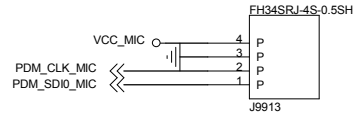
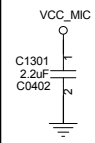
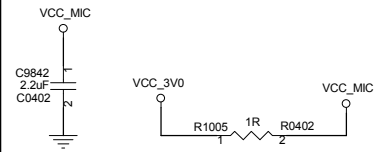
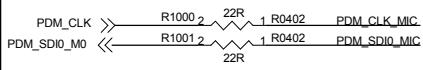

Model	SCAN_PEN	Sheet	71_AUDIO2(OPTION)	No	16 of 17
Board	XZY_VT-E02_V1.1	BOARD NO.		Rev.	V1.1
DESIGN	CHECKED	APPROVED		DATE	2020-08-21

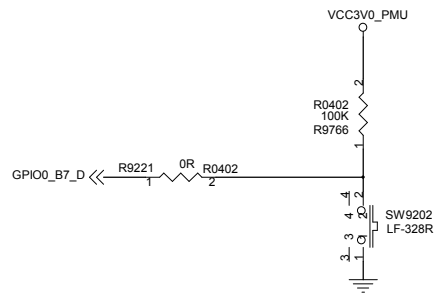
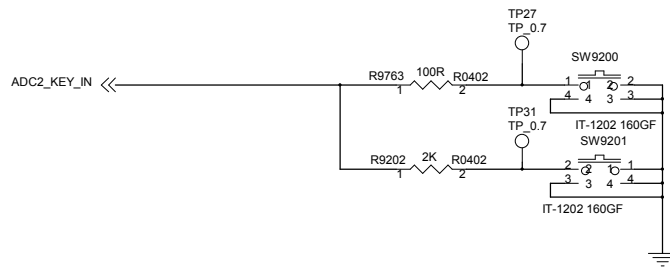

Model		Sheet		No	
SCAN_PEN		92_KEY_BOARD		17 of 17	
Board		BOARD NO.		Rev.	
XZY_VT-E02_V1.1				V1.1	
DESIGN	CHECKED	APPROVED	DATE		
			2020-08-21		