

FCC Test Report

(Part 22&24&27)

Product Name : Advanced Industrial 4G/LTE Router, WWAN Failover Manager
Model No : MX-200, MX-200e, M100
FCC ID : QI3BIL-MX200-R

Applicant : Billion Electric Co., Ltd.
Address : 8F., No.192, Sec. 2, Zhongxing Rd., Xindian Dist.,
New Taipei City 231, Taiwan (R.O.C.)

Date of Receipt : 2017/01/05
Issued Date : 2017/02/18
Report No. : 1710161R-HPUSP43V00
Report Version : V1.0



The test results relate only to the samples tested.

The test results shown in the test report are traceable to the national/international standard through the calibration of the equipment and evaluated measurement uncertainty herein.

This report must not be used to claim product endorsement by TAF or any agency of the government.

The test report shall not be reproduced without the written approval of DEKRA Testing and Certification Co., Ltd.

Test Report

Issued Date : 2017/02/18

Report No.: 1710161R-HPUSP43V00



Product Name : Advanced Industrial 4G/LTE Router, WWAN Failover Manager
Applicant : Billion Electric Co., Ltd.
Address : 8F., No.192, Sec. 2, Zhongxing Rd., Xindian Dist., New Taipei
City 231, Taiwan (R.O.C.)
Manufacturer : Billion Electric Co., Ltd.
Trade Name : BEC, Billion
Model No. : MX-200, MX-200e, M100
EUT Rated Voltage : DC 9-56V
EUT Test Voltage : DC 12V(Power By Adapter AC120V/60Hz)
Measurement Standard : FCC CFR Title 47 Part 2 22 24 27
Measurement Reference : TIA/EIA 603-D
Test Result : Complied

Documented By :

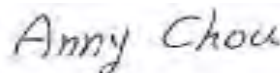

(Senior Adm. Specialist / Anny Chou)

Tested By :



(Senior Engineer / Vorana Chen)

Approved By :



(Director / Vincent Lin)

TABLE OF CONTENTS

Description	Page
1. GENERAL INFORMATION	4
1.1. EUT Description	4
1.2. Antenna List.....	4
1.3. Operational Description.....	5
1.4. Configuration of tested System	6
1.5. EUT Setup Procedures	6
1.6. Test Facility	7
1.7. Type of Emission	8
1.8. Voltages and AC currents	9
2. Technical Test	10
2.1. Summary of test result	10
2.2. List of test Equipment.....	11
2.3. Measurement Uncertainty.....	11
3. Conducted Output Power Measurement	12
3.1. Test Specification	12
3.2. Test Setup	12
3.3. Limits.....	12
3.4. Test Procedure	12
3.5. Test Result of Maximum Power Output.....	13
3.6. Maximum Conducted Power and ERP/EIRP Power	28
4. Occupied Bandwidth	29
4.1. Test Specification	29
4.2. Test Setup	29
4.3. Test Procedure	29
4.4. Test Result of Occupied Bandwidth	30
5. Spurious Emission At Antenna Terminals (+/-1MHz).....	46
5.1. Test Specification	46
5.2. Setup.....	46
5.3. Limits.....	46
5.4. Test Procedure	47
5.5. Test Result of Spurious Emission At Antenna Terminals (+/-1MHz).....	48
6. Spurious Emission	108
6.1. Test Specification	108
6.2. Test Setup	108
6.3. Limits.....	109
6.4. Test Procedure	109
6.5. Test Result of Spurious Emission	110
7. Frequency Stability Under Temperature & Voltage Variations.....	223
7.1. Test Specification	223
7.2. Test Setup	223
7.3. Limits.....	223
7.4. Test Procedure	223
7.5. Test Result of Frequency Stability Under Temperature Variations.....	224
8. Peak to Average Ratio	254
8.1 Test Specification	254
8.2 Test Setup.....	254
8.3 Limits.....	254
8.4 Test Procedure	254
8.5 Test Result of Spurious Emission	255
Attachment 1: EUT Test Photographs	
Attachment 2: EUT Detailed Photographs	

1. GENERAL INFORMATION

1.1. EUT Description

Product Name	Advanced Industrial 4G/LTE Router, WWAN Failover Manager
Model No.	MX-200, MX-200e, M100
Trade Name	BEC, Billion
IMEI No.	35907206
FCC ID	QI3BIL-MX200-R
Modulation	LTE Band 25 : QPSK/16-QAM LTE Band 26 : QPSK/16-QAM LTE Band 41 : QPSK/16-QAM
TX Frequency	LTE Band 25: 1850~1915MHz LTE Band 26 : 824MHz~849MHz LTE Band 41: 2496~2690MHz
Rx Frequency	LTE Band 25: 1930~1995MHz LTE Band 26: 869~894MHz LTE Band 41: 2496~2690MHz
Bandwidth	LTE Band 25: 1.4MHz/3MHz/5MHz/10MHz/15MHz/20MHz LTE Band 26: 1.4MHz/3MHz/5MHz/10MHz/15MHz LTE Band 41: 5MHz/10MHz/15MHz/20MHz
HW Version	1.011
SW Version	1.04.1.103p
Antenna Type	Dipole

Note: 1.The EUT is including three models.

2.The difference of each model is shown as below:

Hardware & Software comparison table:

	MX-200	M100	MX-200e
Trade Name	BEC	Billion	BEC
Hardware design	PCBA/Layout/Scheme/ Key component/housing / interface ...100% same		
LTE antennas (SMA)	Detachable LTE Antenna *2pcs	Detachable LTE Antenna *2pcs	Detachable LTE Antenna *2pcs
GPS antenna (SMA)	1	1	1
SIM slot (2FF)	1	1	1
RS-232 (DB-9)	1	1	1
Ethernet Giga port	2	2	2
Power input	9-56VDC	9-56VDC	9-56VDC
External color	Casing: Metal/Black	Casing: Metal/Black	Casing: Metal/Black
Software function	with VPN	with VPN	without VPN

1.2. Antenna List

No.	Manufacturer	Part No.	Peak Gain
1	Cortec Technolgy Inc.	AN0727-64DP5BSM	0.71 dBi for 700-960MHz 3.7 dBi for 1710-2700MHz

1.3. Operational Description

The information contained within this report is intended to show verification of compliance of the 850/1900/2500MHz to the requirements of FCC 47 CFR Part 2, 22, 24 and 27.

The EUT provide all functions described as above. The EUT is tested with maximum rated TX power via the Base Station simulator.

DEKRA has verified the construction and function in typical operation. All the test modes were carried out with the EUT in normal operation, which was shown in this test report and defined

as:

Test Mode:	LTE Band 25 (1.4M)-QPSK/16QAM
	LTE Band 25 (3M)-QPSK/16QAM
	LTE Band 25 (5M)-QPSK/16QAM
	LTE Band 25 (10M)-QPSK/16QAM
	LTE Band 25 (15M)-QPSK/16QAM
	LTE Band 25 (20M)-QPSK/16QAM
	LTE Band 26 (1.4M)-QPSK/16QAM
	LTE Band 26 (3M)-QPSK/16QAM
	LTE Band 26 (5M)-QPSK/16QAM
	LTE Band 26 (10M)-QPSK/16QAM
	LTE Band 26 (15M)-QPSK/16QAM
	LTE Band 41 (5M)-QPSK/16QAM
	LTE Band 41 (10M)-QPSK/16QAM
	LTE Band 41 (15M)-QPSK/16QAM
	LTE Band 41 (20M)-QPSK/16QAM

Note :

The maximum power levels are chosen in the LTE Band 25/26/41, only these modes were used for all tests.

1.4. Configuration of tested System

(a) Configuration of Radiated measurement

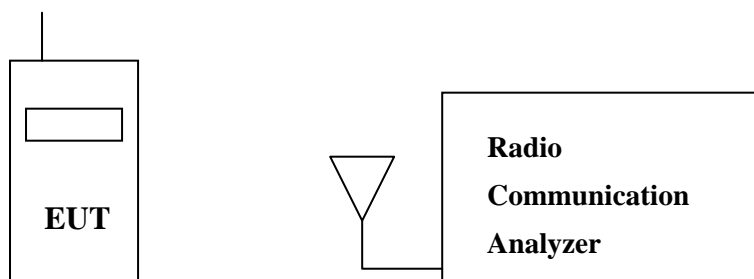

(b) Configuration of Conducted measurement

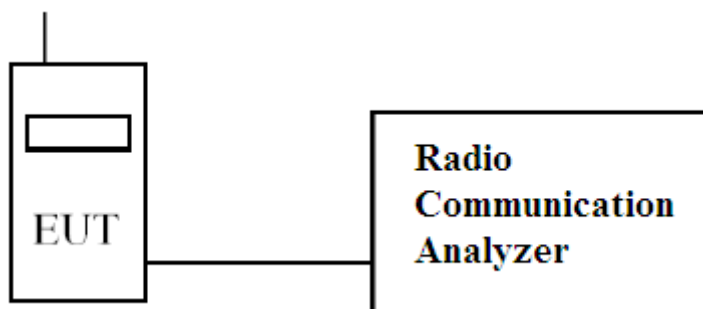

1.5. EUT Setup Procedures

- (1) Setup the EUT and simulators as shown on 1.3
- (2) Turn on the power of all equipments.
- (3) The EUT was set to communicate with MT8820C.
- (4) Repeat the above procedure (3).

1.6. Test Facility

Ambient conditions in the laboratory:

Items	Required (IEC 68-1)	Actual
Temperature (°C)	15-35	22
Humidity (%RH)	25-75	51
Barometric pressure (mbar)	860-1060	988

The related certificate for our laboratories about the test site and management system can be downloaded from DEKRA Testing and Certification Co., Ltd. Web Site:

<http://www.dekra.com.tw/english/about/certificates.aspx?bval=5>

The address and introduction of DEKRA Testing and Certification Co., Ltd. laboratories can be founded in our Web site: http://www.dekra.com.tw/index_en.aspx

Site Description: File on

Federal Communications Commission
FCC Engineering Laboratory
7435 Oakland Mills Road
Columbia, MD 21046
FCC Registration Number :92195

Site Name: DEKRA Testing and Certification Co., Ltd

Site Address: No.5-22, Ruishukeng, Linkou Dist., New Taipei City 24451,
Taiwan, R.O.C.

TEL : 886-2-8601-3788 / FAX : 886-2-8601-3789

E-Mail : info.tw@dekra.com

FCC Accreditation Number: TW1014

1.7. Type of Emission

Band	Bandwidth (MHz)	Modulation	
		QPSK	16QAM
25	1.4	1M09G7D	1M09W7D
25	3	2M74G7D	2M73W7D
25	5	4M51G7D	4M48W7D
25	10	9M06G7D	9M05W7D
25	15	13M5G7D	13M5W7D
25	20	18M6G7D	18M5W7D
26	1.4	1M09G7D	1M09W7D
26	3	2M74G7D	2M72W7D
26	5	4M50G7D	4M48W7D
26	10	9M04G7D	9M03W7D
26	15	13M5G7D	13M5W7D
41	5	4M50G7D	4M49W7D
41	10	9M03G7D	9M03W7D
41	15	13M5G7D	13M5W7D
41	20	18M6G7D	18M5W7D

1.8. Voltages and AC currents

LTE Band 25 (1.4M)	EUT Transmitting (in maximum power) :	AC voltage : 120V , AC current : 0.08A
	EUT Standby :	AC voltage : 120V , AC current : 0.05A
LTE Band 25 (3M)	EUT Transmitting (in maximum power) :	AC voltage : 120V , AC current : 0.08A
	EUT Standby :	AC voltage : 120V , AC current : 0.05A
LTE Band 25 (5M)	EUT Transmitting (in maximum power) :	AC voltage : 120V , AC current : 0.08A
	EUT Standby :	AC voltage : 120V , AC current : 0.05A
LTE Band 25 (10M)	EUT Transmitting (in maximum power) :	AC voltage : 120V , AC current : 0.08A
	EUT Standby :	AC voltage : 120V , AC current : 0.05A
LTE Band 25 (15M)	EUT Transmitting (in maximum power) :	AC voltage : 120V , AC current : 0.09A
	EUT Standby :	AC voltage : 120V , AC current : 0.05A
LTE Band 25 (20M)	EUT Transmitting (in maximum power) :	AC voltage : 120V , AC current : 0.09A
	EUT Standby :	AC voltage : 120V , AC current : 0.05A
LTE Band 26 (1.4M)	EUT Transmitting (in maximum power) :	AC voltage : 120V , AC current : 0.08A
	EUT Standby :	AC voltage : 120V , AC current : 0.05A
LTE Band 26 (3M)	EUT Transmitting (in maximum power) :	AC voltage : 120V , AC current : 0.08A
	EUT Standby :	AC voltage : 120V , AC current : 0.05A
LTE Band 26 (5M)	EUT Transmitting (in maximum power) :	AC voltage : 120V , AC current : 0.08A
	EUT Standby :	AC voltage : 120V , AC current : 0.05A
LTE Band 26 (10M)	EUT Transmitting (in maximum power) :	AC voltage : 120V , AC current : 0.08A
	EUT Standby :	AC voltage : 120V , AC current : 0.05A
LTE Band 26 (15M)	EUT Transmitting (in maximum power) :	AC voltage : 120V , AC current : 0.08A
	EUT Standby :	AC voltage : 120V , AC current : 0.05A
LTE Band 41 (5M)	EUT Transmitting (in maximum power) :	AC voltage : 120V , AC current : 0.07A
	EUT Standby :	AC voltage : 120V , AC current : 0.05A
LTE Band 41 (10M)	EUT Transmitting (in maximum power) :	AC voltage : 120V , AC current : 0.07A
	EUT Standby :	AC voltage : 120V , AC current : 0.05A
LTE Band 41 (15M)	EUT Transmitting (in maximum power) :	AC voltage : 120V , AC current : 0.07A
	EUT Standby :	AC voltage : 120V , AC current : 0.05A
LTE Band 41 (20M)	EUT Transmitting (in maximum power) :	AC voltage : 120V , AC current : 0.07A
	EUT Standby :	AC voltage : 120V , AC current : 0.05A

2. Technical Test

2.1. Summary of test result

FCC Standard	Test Item	Result	Note
2.1046	Conducted Output Power	Pass	
22.913(a)			
24.232(c)			
27.5			
2.1049	Occupied Bandwidth	Pass	
22.917(a)			
24.238(b)			
27.53(m)			
2.1051	Spurious Emission at Antenna Terminals	Pass	
22.917(a)			
24.238(a)			
27.53(m)			
2.1051	Conducted Emission	Pass	
22.917(a)			
24.238(a)			
27.53(m)			
2.1053	Field Strength of Spurious Radiation	Pass	
22.917(a)			
24.238(a)			
27.53(m)			
2.1055	Frequency Stability for Temperature & Voltage	Pass	
22.355			
24.235			
27.54			
24.232(d)	Peak to Average Ratio	Pass	
27.50(a)			

2.2. List of test Equipment

Conducted /CTR

Instrument	Manufacturer	Type No.	Serial No	Cal. Date
Spectrum Analyzer	Agilent	N9010A	MY52220597	2016/02/18
Directional coupler	Agilent	87300C	MY44300353	2016/11/04
Directional coupler	Agilent	778D-012	50550	2016/11/08
Standard Temperature & Humidity Chamber	WIT	TH-1S-B	EQ-201-00146	2016/11/28
DC power supply	Agilent	E3610A	MY40009845	2016/07/14
Communication Tester	Agilent	8820C	6201465467	2016/06/21

Radiated / Site3

Instrument	Manufacturer	Type No.	Serial No	Cal. Date
Bilog Antenna	Schaffner Chase	CBL6112B	2707	2016/06/11
Horn Antenna	R&S	9120D	576	2016/11/24
Pre-Amplifier	Agilent	87405C	MY47010653	2016/08/11
Spectrum Analyzer	Agilent	N9010A	MY52220597	2016/02/18
DC power supply	Agilent	E3610A	MY40009845	2016/07/14
Communication Tester	Agilent	8820C	6201465467	2016/06/21

2.3. Measurement Uncertainty

Conducted Emission

The measurement uncertainty of confidence of 95% is evaluated as ± 1.52 dB

Radiated Emission (Below 1GHz)

The measurement uncertainty of confidence of 95% is evaluated as ± 3.44 dB .

Radiated Emission (Above 1GHz)

The measurement uncertainty of confidence of 95% is evaluated as ± 4.08 dB

3. Conducted Output Power Measurement

3.1. Test Specification

According to FCC Part 2.1046, 22.913, 24.232, 27.50

3.2. Test Setup

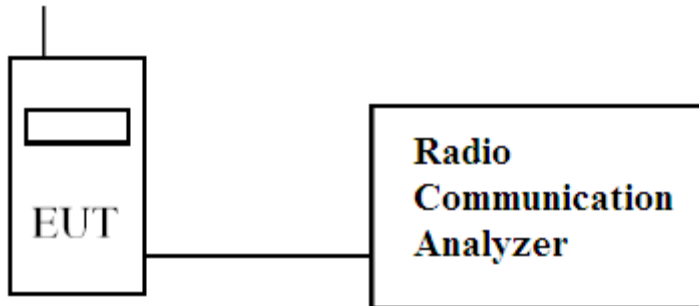

3.3. Limits

Band	Limit
LTE Band 25/1900	<2W
LTE Band 26/850	<7W
LTE Band 41/2500	<2W

3.4. Test Procedure

The EUT is tested with maximum rated TX power via the Base Station simulator, and the output power was measured at the antenna terminals of the EUT.

3.5. Test Result of Maximum Power Output

Band	Channel	Modulation	RB No.	RB Offset	MPR	Max Power (dBm)	Max Power (W)
Band 25 (1900MHz)/1.4MHz	1850.7MHz CH26047	QPSK	1	#0	0	22.94	0.197
			1	#Mid	0	23.25	0.211
			1	#Max	0	22.87	0.194
			50%	#0	1	23.03	0.201
			50%	#Mid	1	23.09	0.204
			50%	#Max	1	22.97	0.198
			100%	--	1	22.00	0.158
		16QAM	1	#0	1	22.20	0.166
			1	#Mid	1	22.39	0.173
			1	#Max	1	22.17	0.165
			50%	#0	2	22.19	0.166
			50%	#Mid	2	22.07	0.161
			50%	#Max	2	22.10	0.162
			100%	--	2	21.12	0.129
	1882.5MHz CH26365	QPSK	1	#0	0	23.06	0.202
			1	#Mid	0	23.13	0.206
			1	#Max	0	22.87	0.194
			50%	#0	1	22.99	0.199
			50%	#Mid	1	23.06	0.202
			50%	#Max	1	22.98	0.199
			100%	--	1	21.91	0.155
		16QAM	1	#0	1	22.34	0.171
			1	#Mid	1	22.26	0.168
			1	#Max	1	22.26	0.168
			50%	#0	2	21.92	0.156
			50%	#Mid	2	22.06	0.161
			50%	#Max	2	22.08	0.161
			100%	--	2	21.03	0.127
	1914.3MHz CH26683	QPSK	1	#0	0	23.13	0.206
			1	#Mid	0	23.10	0.204
1			#Max	0	23.01	0.200	
50%			#0	1	22.93	0.196	
50%			#Mid	1	23.05	0.202	
50%			#Max	1	22.96	0.198	
100%			--	1	21.95	0.157	
16QAM		1	#0	1	22.47	0.177	
		1	#Mid	1	22.23	0.167	
		1	#Max	1	22.34	0.171	
		50%	#0	2	21.93	0.156	
		50%	#Mid	2	22.04	0.160	
		50%	#Max	2	22.05	0.160	
		100%	--	2	21.00	0.126	

Band	Frequency Channel	Modulation	RB No.	RB Offset	MPR	Max Power (Conducted)	Max Power (W)
Band 25 (1900MHz)/3MHz	1851.5MHz CH26055	QPSK	1	#0	0	23.20	0.209
			1	#Mid	0	23.30	0.214
			1	#Max	0	23.05	0.202
			50%	#0	1	22.04	0.160
			50%	#Mid	1	22.14	0.164
			50%	#Max	1	22.02	0.159
			100%	--	1	22.06	0.161
		16QAM	1	#0	1	22.32	0.171
			1	#Mid	1	22.32	0.171
			1	#Max	1	22.34	0.171
			50%	#0	2	21.13	0.130
			50%	#Mid	2	21.19	0.132
			50%	#Max	2	21.08	0.128
			100%	--	2	21.06	0.128
	1882.5MHz CH26365	QPSK	1	#0	0	23.07	0.203
			1	#Mid	0	23.19	0.208
			1	#Max	0	23.08	0.203
			50%	#0	1	22.11	0.163
			50%	#Mid	1	22.11	0.163
			50%	#Max	1	22.04	0.160
			100%	--	1	22.03	0.160
		16QAM	1	#0	1	22.27	0.169
			1	#Mid	1	22.35	0.172
			1	#Max	1	22.42	0.175
			50%	#0	2	21.20	0.132
			50%	#Mid	2	21.16	0.131
			50%	#Max	2	21.08	0.128
			100%	--	2	21.08	0.128
	1913.5MHz CH26675	QPSK	1	#0	0	23.14	0.206
			1	#Mid	0	23.36	0.217
1			#Max	0	23.07	0.203	
50%			#0	1	22.04	0.160	
50%			#Mid	1	22.12	0.163	
50%			#Max	1	22.16	0.164	
100%			--	1	22.07	0.161	
16QAM		1	#0	1	22.43	0.175	
		1	#Mid	1	22.38	0.173	
		1	#Max	1	22.32	0.171	
		50%	#0	2	21.15	0.130	
		50%	#Mid	2	21.11	0.129	
		50%	#Max	2	21.05	0.127	
		100%	--	2	21.04	0.127	

Band	Frequency Channel	Modulation	RB No.	RB Offset	MPR	Max Power (Conducted)	Max Power (W)
Band 25 (1900MHz)/5MHz	1852.5MHz CH26065	QPSK	1	#0	0	23.06	0.202
			1	#Mid	0	23.00	0.200
			1	#Max	0	22.85	0.193
			50%	#0	1	21.95	0.157
			50%	#Mid	1	21.99	0.158
			50%	#Max	1	21.91	0.155
			100%	--	1	21.95	0.157
		16QAM	1	#0	1	22.36	0.172
			1	#Mid	1	22.20	0.166
			1	#Max	1	22.47	0.177
			50%	#0	2	21.01	0.126
			50%	#Mid	2	21.04	0.127
	50%		#Max	2	20.94	0.124	
	100%		--	2	21.00	0.126	
	1882.5MHz CH26365	QPSK	1	#0	0	23.17	0.207
			1	#Mid	0	22.91	0.195
			1	#Max	0	23.00	0.200
			50%	#0	1	22.08	0.161
			50%	#Mid	1	22.12	0.163
			50%	#Max	1	22.13	0.163
			100%	--	1	22.09	0.162
		16QAM	1	#0	1	22.32	0.171
			1	#Mid	1	22.58	0.181
			1	#Max	1	22.31	0.170
			50%	#0	2	21.12	0.129
			50%	#Mid	2	21.12	0.129
	50%		#Max	2	21.18	0.131	
	100%		--	2	21.12	0.129	
	1912.5MHz CH26665	QPSK	1	#0	0	23.18	0.208
			1	#Mid	0	23.19	0.208
			1	#Max	0	23.05	0.202
			50%	#0	1	22.08	0.161
			50%	#Mid	1	22.10	0.162
			50%	#Max	1	22.17	0.165
			100%	--	1	22.13	0.163
		16QAM	1	#0	1	22.38	0.173
1			#Mid	1	22.53	0.179	
1			#Max	1	22.42	0.175	
50%			#0	2	21.07	0.128	
50%			#Mid	2	21.05	0.127	
50%	#Max		2	21.12	0.129		
100%	--		2	21.09	0.129		

Band	Frequency Channel	Modulation	RB No.	RB Offset	MPR	Max Power (Conducted)	Max Power (W)
Band 25 (1900MHz)/10MHz	1855MHz CH26090	QPSK	1	#0	0	23.15	0.207
			1	#Mid	0	23.32	0.215
			1	#Max	0	22.97	0.198
			50%	#0	1	22.04	0.160
			50%	#Mid	1	21.99	0.158
			50%	#Max	1	21.96	0.157
			100%	--	1	21.98	0.158
		16QAM	1	#0	1	22.42	0.175
			1	#Mid	1	22.38	0.173
			1	#Max	1	22.30	0.170
			50%	#0	2	21.05	0.127
			50%	#Mid	2	21.00	0.126
			50%	#Max	2	21.00	0.126
			100%	--	2	20.99	0.126
	1882.5MHz CH26365	QPSK	1	#0	0	23.17	0.207
			1	#Mid	0	23.31	0.214
			1	#Max	0	23.10	0.204
			50%	#0	1	22.14	0.164
			50%	#Mid	1	22.13	0.163
			50%	#Max	1	22.09	0.162
			100%	--	1	22.11	0.163
		16QAM	1	#0	1	22.63	0.183
			1	#Mid	1	22.50	0.178
			1	#Max	1	22.46	0.176
			50%	#0	2	21.14	0.130
			50%	#Mid	2	21.20	0.132
			50%	#Max	2	21.12	0.129
			100%	--	2	21.09	0.129
	1910MHz CH26640	QPSK	1	#0	0	23.07	0.203
			1	#Mid	0	23.41	0.219
1			#Max	0	23.23	0.210	
50%			#0	1	22.08	0.161	
50%			#Mid	1	22.05	0.160	
50%			#Max	1	22.12	0.163	
100%			--	1	22.07	0.161	
16QAM		1	#0	1	22.35	0.172	
		1	#Mid	1	22.64	0.184	
		1	#Max	1	22.32	0.171	
		50%	#0	2	21.15	0.130	
		50%	#Mid	2	21.11	0.129	
		50%	#Max	2	21.09	0.129	
		100%	--	2	21.12	0.129	

Band	Frequency Channel	Modulation	RB No.	RB Offset	MPR	Max Power (Conducted)	Max Power (W)
Band 25 (1900MHz)/15MHz	1857.5MHz CH26115	QPSK	1	#0	0	23.20	0.209
			1	#Mid	0	23.27	0.212
			1	#Max	0	23.14	0.206
			50%	#0	1	22.24	0.167
			50%	#Mid	1	22.31	0.170
			50%	#Max	1	22.29	0.169
			100%	--	1	22.24	0.167
		16QAM	1	#0	1	22.62	0.183
			1	#Mid	1	22.71	0.187
			1	#Max	1	22.55	0.180
			50%	#0	2	21.23	0.133
			50%	#Mid	2	21.34	0.136
			50%	#Max	2	21.28	0.134
			100%	--	2	21.28	0.134
	1882.5MHz CH26365	QPSK	1	#0	0	23.25	0.211
			1	#Mid	0	23.17	0.207
			1	#Max	0	23.21	0.209
			50%	#0	1	22.32	0.171
			50%	#Mid	1	22.30	0.170
			50%	#Max	1	22.22	0.167
			100%	--	1	22.23	0.167
		16QAM	1	#0	1	22.70	0.186
			1	#Mid	1	22.72	0.187
			1	#Max	1	22.50	0.178
			50%	#0	2	21.32	0.136
			50%	#Mid	2	21.31	0.135
			50%	#Max	2	21.22	0.132
			100%	--	2	21.27	0.134
	1907.5MHz CH26615	QPSK	1	#0	0	23.16	0.207
			1	#Mid	0	23.28	0.213
1			#Max	0	23.17	0.207	
50%			#0	1	22.14	0.164	
50%			#Mid	1	22.17	0.165	
50%			#Max	1	22.11	0.163	
100%			--	1	22.26	0.168	
16QAM		1	#0	1	22.54	0.179	
		1	#Mid	1	22.42	0.175	
		1	#Max	1	22.32	0.171	
		50%	#0	2	21.14	0.130	
		50%	#Mid	2	21.21	0.132	
		50%	#Max	2	21.12	0.129	
		100%	--	2	21.27	0.134	

Band	Frequency Channel	Modulation	RB No.	RB Offset	MPR	Max Power (Conducted)	Max Power (W)
Band 25 (1900MHz)/20MHz	1860MHz CH26140	QPSK	1	#0	0	23.18	0.208
			1	#Mid	0	23.20	0.209
			1	#Max	0	22.92	0.196
			50%	#0	1	22.26	0.168
			50%	#Mid	1	22.29	0.169
			50%	#Max	1	22.22	0.167
			100%	--	1	22.18	0.165
		16QAM	1	#0	1	22.55	0.180
			1	#Mid	1	22.68	0.185
			1	#Max	1	22.30	0.170
			50%	#0	2	21.19	0.132
			50%	#Mid	2	21.26	0.134
			50%	#Max	2	21.22	0.132
			100%	--	2	21.23	0.133
	1882.5MHz CH26365	QPSK	1	#0	0	23.30	0.214
			1	#Mid	0	23.27	0.212
			1	#Max	0	23.09	0.204
			50%	#0	1	22.36	0.172
			50%	#Mid	1	22.30	0.170
			50%	#Max	1	22.28	0.169
			100%	--	1	22.30	0.170
		16QAM	1	#0	1	22.71	0.187
			1	#Mid	1	22.80	0.191
			1	#Max	1	22.44	0.175
			50%	#0	2	21.40	0.138
			50%	#Mid	2	21.31	0.135
			50%	#Max	2	21.22	0.132
			100%	--	2	21.31	0.135
	1905MHz CH26590	QPSK	1	#0	0	23.33	0.215
			1	#Mid	0	23.36	0.217
			1	#Max	0	23.03	0.201
			50%	#0	1	22.26	0.168
			50%	#Mid	1	22.21	0.166
			50%	#Max	1	22.21	0.166
			100%	--	1	22.23	0.167
		16QAM	1	#0	1	22.62	0.183
1			#Mid	1	22.73	0.187	
1			#Max	1	22.41	0.174	
50%			#0	2	21.30	0.135	
50%			#Mid	2	21.31	0.135	
50%			#Max	2	21.23	0.133	
100%			--	2	21.21	0.132	

Band	Frequency Channel	Modulation	RB No.	RB Offset	MPR	Max Power (dBm)	Max Power (W)
Band 26 (850MHz)/1.4MHz	824.7MHz CH26797	QPSK	1	#0	0	22.90	0.195
			1	#Mid	0	22.69	0.186
			1	#Max	0	22.52	0.179
			50%	#0	1	22.56	0.180
			50%	#Mid	1	22.54	0.179
			50%	#Max	1	22.53	0.179
			100%	--	1	21.51	0.142
		16QAM	1	#0	1	22.12	0.163
			1	#Mid	1	21.88	0.154
			1	#Max	1	22.00	0.158
			50%	#0	2	21.56	0.143
			50%	#Mid	2	21.85	0.153
			50%	#Max	2	21.53	0.142
			100%	--	2	20.47	0.111
	836.5MHz CH26915	QPSK	1	#0	0	22.50	0.178
			1	#Mid	0	22.45	0.176
			1	#Max	0	22.37	0.173
			50%	#0	1	22.26	0.168
			50%	#Mid	1	22.33	0.171
			50%	#Max	1	22.27	0.169
			100%	--	1	21.38	0.137
		16QAM	1	#0	1	21.66	0.147
			1	#Mid	1	21.92	0.156
			1	#Max	1	22.16	0.164
			50%	#0	2	21.38	0.137
			50%	#Mid	2	21.51	0.142
			50%	#Max	2	21.34	0.136
			100%	--	2	20.69	0.117
	848.3MHz CH27033	QPSK	1	#0	0	22.82	0.191
			1	#Mid	0	22.72	0.187
			1	#Max	0	22.79	0.190
			50%	#0	1	22.45	0.176
			50%	#Mid	1	22.54	0.179
			50%	#Max	1	22.48	0.177
			100%	--	1	21.53	0.142
		16QAM	1	#0	1	22.30	0.170
1			#Mid	1	22.15	0.164	
1			#Max	1	22.15	0.164	
50%			#0	2	21.47	0.140	
50%			#Mid	2	21.84	0.153	
50%			#Max	2	21.51	0.142	
100%			--	2	20.69	0.117	

Band	Frequency Channel	Modulation	RB No.	RB Offset	MPR	Max Power (Conducted)	Max Power (W)
Band 26 (850MHz)/3MHz	825.5MHz CH26805	QPSK	1	#0	0	22.86	0.193
			1	#Mid	0	22.97	0.198
			1	#Max	0	22.57	0.181
			50%	#0	1	21.50	0.141
			50%	#Mid	1	21.61	0.145
			50%	#Max	1	21.57	0.144
			100%	--	1	21.57	0.144
		16QAM	1	#0	1	22.16	0.164
			1	#Mid	1	22.34	0.171
			1	#Max	1	21.99	0.158
			50%	#0	2	20.58	0.114
			50%	#Mid	2	20.69	0.117
			50%	#Max	2	20.66	0.116
			100%	--	2	20.58	0.114
	836.5MHz CH26915	QPSK	1	#0	0	22.52	0.179
			1	#Mid	0	22.59	0.182
			1	#Max	0	22.54	0.179
			50%	#0	1	21.40	0.138
			50%	#Mid	1	21.32	0.136
			50%	#Max	1	21.26	0.134
			100%	--	1	21.31	0.135
		16QAM	1	#0	1	21.84	0.153
			1	#Mid	1	21.94	0.156
			1	#Max	1	21.71	0.148
			50%	#0	2	20.48	0.112
			50%	#Mid	2	20.52	0.113
			50%	#Max	2	20.45	0.111
			100%	--	2	20.30	0.107
	847.5MHz CH27025	QPSK	1	#0	0	22.61	0.182
			1	#Mid	0	22.61	0.182
1			#Max	0	22.52	0.179	
50%			#0	1	21.57	0.144	
50%			#Mid	1	21.59	0.144	
50%			#Max	1	21.59	0.144	
100%			--	1	21.56	0.143	
16QAM		1	#0	1	22.09	0.162	
		1	#Mid	1	22.26	0.168	
		1	#Max	1	22.20	0.166	
		50%	#0	2	20.65	0.116	
		50%	#Mid	2	20.66	0.116	
		50%	#Max	2	20.60	0.115	
		100%	--	2	20.59	0.115	

Band	Frequency Channel	Modulation	RB No.	RB Offset	MPR	Max Power (Conducted)	Max Power (W)
Band 26 (850MHz)/5MHz	826.5MHz CH26815	QPSK	1	#0	0	22.59	0.182
			1	#Mid	0	22.66	0.185
			1	#Max	0	22.62	0.183
			50%	#0	1	21.58	0.144
			50%	#Mid	1	21.61	0.145
			50%	#Max	1	21.70	0.148
			100%	--	1	21.70	0.148
		16QAM	1	#0	1	22.07	0.161
			1	#Mid	1	22.19	0.166
			1	#Max	1	22.09	0.162
			50%	#0	2	20.59	0.115
			50%	#Mid	2	20.58	0.114
			50%	#Max	2	20.72	0.118
			100%	--	2	20.54	0.113
	836.5MHz CH26915	QPSK	1	#0	0	22.43	0.175
			1	#Mid	0	22.46	0.176
			1	#Max	0	22.40	0.174
			50%	#0	1	21.43	0.139
			50%	#Mid	1	21.41	0.138
			50%	#Max	1	21.27	0.134
			100%	--	1	21.27	0.134
		16QAM	1	#0	1	21.81	0.152
			1	#Mid	1	22.09	0.162
			1	#Max	1	21.79	0.151
			50%	#0	2	20.39	0.109
			50%	#Mid	2	20.43	0.110
			50%	#Max	2	20.29	0.107
			100%	--	2	20.24	0.106
	846.5MHz CH27015	QPSK	1	#0	0	22.61	0.182
			1	#Mid	0	22.85	0.193
			1	#Max	0	22.63	0.183
			50%	#0	1	21.55	0.143
			50%	#Mid	1	21.65	0.146
			50%	#Max	1	21.53	0.142
			100%	--	1	21.58	0.144
		16QAM	1	#0	1	22.05	0.160
1			#Mid	1	22.21	0.166	
1			#Max	1	22.05	0.160	
50%			#0	2	20.49	0.112	
50%			#Mid	2	20.64	0.116	
50%			#Max	2	20.57	0.114	
100%			--	2	20.54	0.113	

Band	Frequency Channel	Modulation	RB No.	RB Offset	MPR	Max Power (Conducted)	Max Power (W)
Band 26 (850MHz)/10MHz	829MHz CH26840	QPSK	1	#0	0	22.51	0.178
			1	#Mid	0	22.52	0.179
			1	#Max	0	22.44	0.175
			50%	#0	1	21.47	0.140
			50%	#Mid	1	21.53	0.142
			50%	#Max	1	21.50	0.141
			100%	--	1	21.45	0.140
		16QAM	1	#0	1	21.58	0.144
			1	#Mid	1	21.99	0.158
			1	#Max	1	21.95	0.157
			50%	#0	2	20.43	0.110
			50%	#Mid	2	20.43	0.110
			50%	#Max	2	20.41	0.110
			100%	--	2	20.44	0.111
	836.5MHz CH26915	QPSK	1	#0	0	22.75	0.188
			1	#Mid	0	22.78	0.190
			1	#Max	0	22.32	0.171
			50%	#0	1	21.43	0.139
			50%	#Mid	1	21.31	0.135
			50%	#Max	1	21.42	0.139
			100%	--	1	21.45	0.140
		16QAM	1	#0	1	21.99	0.158
			1	#Mid	1	22.06	0.161
			1	#Max	1	22.00	0.158
			50%	#0	2	20.29	0.107
			50%	#Mid	2	20.38	0.109
			50%	#Max	2	20.28	0.107
			100%	--	2	20.39	0.109
	844MHz CH26990	QPSK	1	#0	0	22.56	0.180
			1	#Mid	0	22.85	0.193
1			#Max	0	22.50	0.178	
50%			#0	1	21.60	0.145	
50%			#Mid	1	21.59	0.144	
50%			#Max	1	21.58	0.144	
100%			--	1	21.65	0.146	
16QAM		1	#0	1	22.10	0.162	
		1	#Mid	1	22.26	0.168	
		1	#Max	1	22.00	0.158	
		50%	#0	2	20.68	0.117	
		50%	#Mid	2	20.53	0.113	
		50%	#Max	2	20.54	0.113	
		100%	--	2	20.54	0.113	

Band	Frequency Channel	Modulation	RB No.	RB Offset	MPR	Max Power (Conducted)	Max Power (W)
Band 26 (850MHz)/15MHz	831.5MHz CH26865	QPSK	1	#0	0	22.86	0.193
			1	#Mid	0	22.90	0.195
			1	#Max	0	22.69	0.186
			50%	#0	1	21.90	0.155
			50%	#Mid	1	21.93	0.156
			50%	#Max	1	21.81	0.152
			100%	--	1	21.86	0.153
		16QAM	1	#0	1	22.12	0.163
			1	#Mid	1	22.18	0.165
			1	#Max	1	21.98	0.158
			50%	#0	2	20.88	0.122
			50%	#Mid	2	20.88	0.122
			50%	#Max	2	20.68	0.117
			100%	--	2	20.75	0.119
	836.5MHz CH26915	QPSK	1	#0	0	22.67	0.185
			1	#Mid	0	22.62	0.183
			1	#Max	0	22.48	0.177
			50%	#0	1	21.67	0.147
			50%	#Mid	1	21.66	0.147
			50%	#Max	1	21.49	0.141
			100%	--	1	21.57	0.144
		16QAM	1	#0	1	22.00	0.158
			1	#Mid	1	21.91	0.155
			1	#Max	1	21.73	0.149
			50%	#0	2	20.63	0.116
			50%	#Mid	2	20.63	0.116
			50%	#Max	2	20.42	0.110
			100%	--	2	20.56	0.114
	841.5MHz CH26965	QPSK	1	#0	0	22.64	0.184
			1	#Mid	0	22.53	0.179
			1	#Max	0	22.52	0.179
			50%	#0	1	21.58	0.144
			50%	#Mid	1	21.62	0.145
			50%	#Max	1	21.60	0.145
			100%	--	1	21.58	0.144
		16QAM	1	#0	1	21.80	0.151
1			#Mid	1	21.80	0.151	
1			#Max	1	21.75	0.150	
50%			#0	2	20.50	0.112	
50%			#Mid	2	20.60	0.115	
50%			#Max	2	20.50	0.112	
100%			--	2	20.55	0.114	

Band	Frequency Channel	Modulation	RB No.	RB Offset	MPR	Max Power (Conducted)	Max Power (W)
Band 41 (2500MHz)/5MHz	2498.5MHz CH39675	QPSK	1	#0	0	21.38	0.137
			1	#Mid	0	21.39	0.138
			1	#Max	0	21.47	0.140
			50%	#0	1	20.42	0.110
			50%	#Mid	1	20.58	0.114
			50%	#Max	1	20.67	0.117
			100%	--	1	20.65	0.116
		16QAM	1	#0	1	20.78	0.120
			1	#Mid	1	20.65	0.116
			1	#Max	1	20.81	0.121
			50%	#0	2	19.58	0.091
			50%	#Mid	2	19.65	0.092
			50%	#Max	2	19.62	0.092
			100%	--	2	19.63	0.092
	2593MHz CH40620	QPSK	1	#0	0	21.52	0.142
			1	#Mid	0	21.27	0.134
			1	#Max	0	21.19	0.132
			50%	#0	1	20.51	0.112
			50%	#Mid	1	20.48	0.112
			50%	#Max	1	20.50	0.112
			100%	--	1	20.44	0.111
		16QAM	1	#0	1	20.84	0.121
			1	#Mid	1	20.69	0.117
			1	#Max	1	20.73	0.118
			50%	#0	2	19.50	0.089
			50%	#Mid	2	19.59	0.091
			50%	#Max	2	19.48	0.089
			100%	--	2	19.46	0.088
	2687.5MHz CH41565	QPSK	1	#0	0	21.49	0.141
			1	#Mid	0	21.02	0.126
			1	#Max	0	21.23	0.133
			50%	#0	1	20.32	0.108
			50%	#Mid	1	20.45	0.111
			50%	#Max	1	20.23	0.105
			100%	--	1	20.31	0.107
		16QAM	1	#0	1	20.47	0.111
1			#Mid	1	20.22	0.105	
1			#Max	1	20.53	0.113	
50%			#0	2	19.29	0.085	
50%			#Mid	2	19.31	0.085	
50%			#Max	2	19.21	0.083	
100%			--	2	19.31	0.085	

Band	Frequency Channel	Modulation	RB No.	RB Offset	MPR	Max Power (dBm)	Max Power (W)
Band 41 (2500MHz)/10MHz	2501MHz CH39700	QPSK	1	#0	0	21.58	0.144
			1	#Mid	0	22.11	0.163
			1	#Max	0	21.71	0.148
			50%	#0	1	20.66	0.116
			50%	#Mid	1	20.53	0.113
			50%	#Max	1	20.56	0.114
			100%	--	1	20.65	0.116
		16QAM	1	#0	1	21.05	0.127
			1	#Mid	1	21.12	0.129
			1	#Max	1	21.20	0.132
			50%	#0	2	19.62	0.092
			50%	#Mid	2	19.72	0.094
			50%	#Max	2	19.73	0.094
			100%	--	2	19.72	0.094
	2593MHz CH40620	QPSK	1	#0	0	21.18	0.131
			1	#Mid	0	21.59	0.144
			1	#Max	0	21.51	0.142
			50%	#0	1	20.45	0.111
			50%	#Mid	1	20.43	0.110
			50%	#Max	1	20.34	0.108
			100%	--	1	20.45	0.111
		16QAM	1	#0	1	20.70	0.117
			1	#Mid	1	20.83	0.121
			1	#Max	1	20.83	0.121
			50%	#0	2	19.46	0.088
			50%	#Mid	2	19.56	0.090
			50%	#Max	2	19.46	0.088
			100%	--	2	19.46	0.088
	2685MHz CH41540	QPSK	1	#0	0	21.37	0.137
			1	#Mid	0	21.85	0.153
			1	#Max	0	21.21	0.132
			50%	#0	1	20.34	0.108
			50%	#Mid	1	20.27	0.106
			50%	#Max	1	20.27	0.106
			100%	--	1	20.28	0.107
		16QAM	1	#0	1	20.77	0.119
1			#Mid	1	20.54	0.113	
1			#Max	1	20.53	0.113	
50%			#0	2	19.43	0.088	
50%			#Mid	2	19.38	0.087	
50%			#Max	2	19.38	0.087	
100%			--	2	19.39	0.087	

Band	Frequency Channel	Modulation	RB No.	RB Offset	MPR	Max Power (Conducted)	Max Power (W)
Band 41 (2500MHz)/15MHz	2503.5MHz CH39725	QPSK	1	#0	0	21.71	0.148
			1	#Mid	0	21.83	0.152
			1	#Max	0	21.80	0.151
			50%	#0	1	20.74	0.119
			50%	#Mid	1	20.93	0.124
			50%	#Max	1	20.82	0.121
			100%	--	1	20.78	0.120
		16QAM	1	#0	1	20.95	0.124
			1	#Mid	1	20.97	0.125
			1	#Max	1	20.93	0.124
			50%	#0	2	19.65	0.092
			50%	#Mid	2	19.72	0.094
			50%	#Max	2	19.84	0.096
			100%	--	2	19.85	0.097
	2593MHz CH40620	QPSK	1	#0	0	21.77	0.150
			1	#Mid	0	21.58	0.144
			1	#Max	0	21.41	0.138
			50%	#0	1	20.59	0.115
			50%	#Mid	1	20.68	0.117
			50%	#Max	1	20.55	0.114
			100%	--	1	20.57	0.114
		16QAM	1	#0	1	21.03	0.127
			1	#Mid	1	20.94	0.124
			1	#Max	1	20.77	0.119
			50%	#0	2	19.46	0.088
			50%	#Mid	2	19.46	0.088
			50%	#Max	2	19.50	0.089
			100%	--	2	19.55	0.090
	2682.5MHz CH41515	QPSK	1	#0	0	21.26	0.134
			1	#Mid	0	21.36	0.137
1			#Max	0	21.06	0.128	
50%			#0	1	20.41	0.110	
50%			#Mid	1	20.53	0.113	
50%			#Max	1	20.45	0.111	
100%			--	1	20.44	0.111	
16QAM		1	#0	1	20.78	0.120	
		1	#Mid	1	20.95	0.124	
		1	#Max	1	20.65	0.116	
		50%	#0	2	19.34	0.086	
		50%	#Mid	2	19.46	0.088	
		50%	#Max	2	19.50	0.089	
		100%	--	2	19.56	0.090	

Band	Frequency Channel	Modulation	RB No.	RB Offset	MPR	Max Power (Conducted)	Max Power (W)
Band 41 (2500MHz)/20MHz	2506MHz CH39750	QPSK	1	#0	0	21.69	0.148
			1	#Mid	0	21.87	0.154
			1	#Max	0	21.59	0.144
			50%	#0	1	20.70	0.117
			50%	#Mid	1	20.91	0.123
			50%	#Max	1	20.74	0.119
			100%	--	1	20.76	0.119
		16QAM	1	#0	1	20.82	0.121
			1	#Mid	1	21.06	0.128
			1	#Max	1	21.04	0.127
			50%	#0	2	19.77	0.095
			50%	#Mid	2	19.88	0.097
			50%	#Max	2	19.72	0.094
			100%	--	2	19.73	0.094
	2593MHz CH40620	QPSK	1	#0	0	21.28	0.134
			1	#Mid	0	21.41	0.138
			1	#Max	0	21.23	0.133
			50%	#0	1	20.48	0.112
			50%	#Mid	1	20.57	0.114
			50%	#Max	1	20.36	0.109
			100%	--	1	20.52	0.113
		16QAM	1	#0	1	20.59	0.115
			1	#Mid	1	20.84	0.121
			1	#Max	1	20.55	0.114
			50%	#0	2	19.50	0.089
			50%	#Mid	2	19.60	0.091
			50%	#Max	2	19.48	0.089
			100%	--	2	19.54	0.090
	2680MHz CH41490	QPSK	1	#0	0	21.29	0.135
			1	#Mid	0	21.40	0.138
1			#Max	0	21.20	0.132	
50%			#0	1	20.35	0.108	
50%			#Mid	1	20.51	0.112	
50%			#Max	1	20.39	0.109	
100%			--	1	20.31	0.107	
16QAM		1	#0	1	20.69	0.117	
		1	#Mid	1	20.88	0.122	
		1	#Max	1	20.33	0.108	
		50%	#0	2	19.47	0.089	
		50%	#Mid	2	19.52	0.090	
		50%	#Max	2	19.42	0.087	
		100%	--	2	19.53	0.090	

3.6. Maximum Conducted Power and ERP/EIRP Power

According to KDB 412172 D01 Section 1.2 Power Approach

$$EIRP = P_T + G_T - L_C = ERP + 2.15 \text{ dB}, ERP = EIRP - 2.15 \text{ dB}$$

P_T = transmitter output power in dBm

G_T = gain of the transmitting antenna in dBi

L_C = signal attenuation in the connecting cable between the transmitter and antenna in dB

LTE Band	BW	Modulation	Conducted Peak Power (dBm)	Conducted Peak Power (W)	Antenna Gain (dBi)	Maximum ERP/EIRP (W)	Maximum ERP/EIRP Limit (W)	
25	1.4M	QPSK	23.25	0.211	3.70	0.495	2	
		16QAM	22.47	0.177	3.70	0.414	2	
	3M	QPSK	23.36	0.217	3.70	0.508	2	
		16QAM	22.43	0.175	3.70	0.410	2	
	5M	QPSK	23.19	0.208	3.70	0.489	2	
		16QAM	22.58	0.181	3.70	0.425	2	
	10M	QPSK	23.41	0.219	3.70	0.514	2	
		16QAM	22.64	0.184	3.70	0.431	2	
	15M	QPSK	23.28	0.213	3.70	0.499	2	
		16QAM	22.72	0.187	3.70	0.439	2	
	20M	QPSK	23.36	0.217	3.70	0.508	2	
		16QAM	22.80	0.191	3.70	0.447	2	
	26	1.4M	QPSK	22.90	0.195	0.71	0.140	7
			16QAM	22.30	0.170	0.71	0.122	7
3M		QPSK	22.97	0.198	0.71	0.142	7	
		16QAM	22.34	0.171	0.71	0.123	7	
5M		QPSK	22.85	0.193	0.71	0.138	7	
		16QAM	22.21	0.166	0.71	0.119	7	
10M		QPSK	22.85	0.193	0.71	0.138	7	
		16QAM	22.26	0.168	0.71	0.121	7	
15M		QPSK	22.90	0.195	0.71	0.140	7	
		16QAM	22.18	0.165	0.71	0.119	7	
41	5M	QPSK	21.52	0.142	3.70	0.333	2	
		16QAM	20.84	0.121	3.70	0.284	2	
	10M	QPSK	22.11	0.163	3.70	0.381	2	
		16QAM	21.20	0.132	3.70	0.309	2	
	15M	QPSK	21.83	0.152	3.70	0.357	2	
		16QAM	21.03	0.127	3.70	0.297	2	
	20M	QPSK	21.87	0.154	3.70	0.361	2	
		16QAM	21.06	0.128	3.70	0.299	2	

4. Occupied Bandwidth

4.1. Test Secification

According to FCC Part 2.1049, 22.917, 24.238, 27.53

4.2. Test Setup

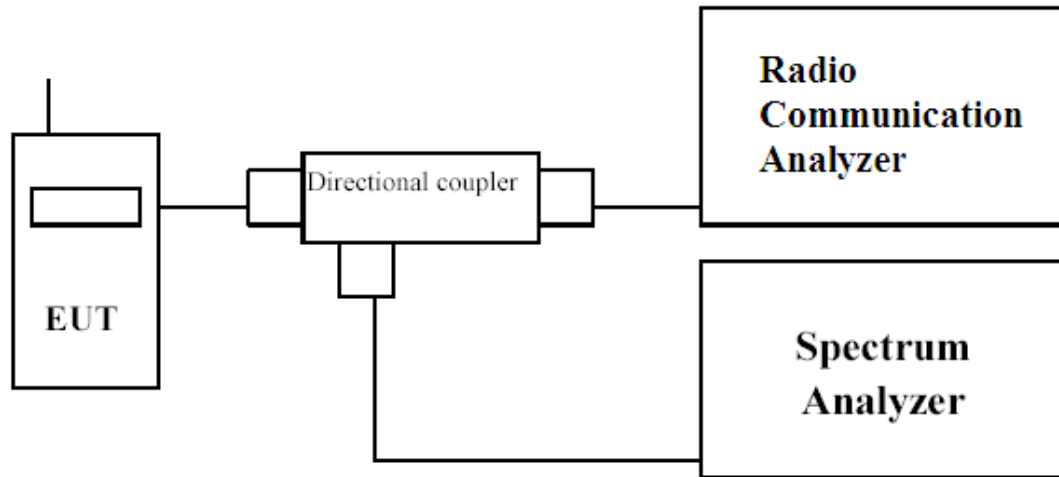

4.3. Test Procedure

The EUT is tested with maximum rated TX power via the Base Station simulator, and the occupied bandwidth was measured at the antenna terminals of the EUT.

The Resolution BW of the analyzer is set to 1 %~5% of the emission bandwidth. The EUT's occupied bandwidth is measured as the width of the signal between two points, one below the carrier center frequency and one above the carrier frequency, outside of which all emissions are attenuated at least 26 dB below the transmitter power.

The plots below show the resultant display from the Spectrum Analyser.

4.4. Test Result of Occupied Bandwidth

Product	Advanced Industrial 4G/LTE Router, WWAN Failover Manager
Test Mode	Occupied Bandwidth
Test Site	CTR

Test Mode	Channel	TX Frequency (MHz)	99% Occupied Bandwidth (MHz)	26 dB bandwidth (MHz)	Result
Band 25 1.4M QPSK	26365	1882.5	1.0943	1.249	Pass
Band 25 1.4M 16QAM	26365	1882.5	1.0915	1.255	Pass
Band 25 3M QPSK	26365	1882.5	2.7362	3.112	Pass
Band 25 3M 16QAM	26365	1882.5	2.7298	3.091	Pass
Band 25 5M QPSK	26365	1882.5	4.5127	4.980	Pass
Band 25 5M 16QAM	26365	1882.5	4.4847	4.930	Pass
Band 25 10M QPSK	26365	1882.5	9.0548	9.989	Pass
Band 25 10M 16QAM	26365	1882.5	9.0503	10.04	Pass
Band 25 15M QPSK	26365	1882.5	13.473	14.76	Pass
Band 25 15M 16QAM	26365	1882.5	13.478	14.67	Pass
Band 25 20M QPSK	26365	1882.5	18.630	20.74	Pass
Band 25 20M 16QAM	26365	1882.5	18.533	20.42	Pass
Band 26 1.4M QPSK	26915	836.5	1.0942	1.243	Pass
Band 26 1.4M 16QAM	26915	836.5	1.0898	1.242	Pass
Band 26 3M QPSK	26915	836.5	2.7360	3.105	Pass
Band 26 3M 16QAM	26915	836.5	2.7195	3.052	Pass
Band 26 5M QPSK	26915	836.5	4.5011	4.942	Pass
Band 26 5M 16QAM	26915	836.5	4.4807	4.924	Pass
Band 26 10M QPSK	26915	836.5	9.0411	9.958	Pass
Band 26 10M 16QAM	26915	836.5	9.0330	9.980	Pass
Band 26 15M QPSK	26915	836.5	13.460	14.68	Pass
Band 26 15M 16QAM	26915	836.5	13.451	14.65	Pass
Band 41 5M QPSK	40620	2593	4.4982	4.937	Pass
Band 41 5M 16QAM	40620	2593	4.4912	4.975	Pass
Band 41 10M QPSK	40620	2593	9.0334	10.37	Pass
Band 41 10M 16QAM	40620	2593	9.0254	10.27	Pass
Band 41 15M QPSK	40620	2593	13.491	15.29	Pass
Band 41 15M 16QAM	40620	2593	13.470	15.09	Pass
Band 41 20M QPSK	40620	2593	18.638	23.60	Pass
Band 41 20M 16QAM	40620	2593	18.529	22.38	Pass

Product	Advanced Industrial 4G/LTE Router, WWAN Failover Manager		
Test Mode	Occupied Bandwidth		
Date of Test	2017/01/17	Test Site	CTR
Test Condition	Band 25 1.4M		

Band 25 1.4M QPSK - LTE Mode CH26365 (1882.5MHz)

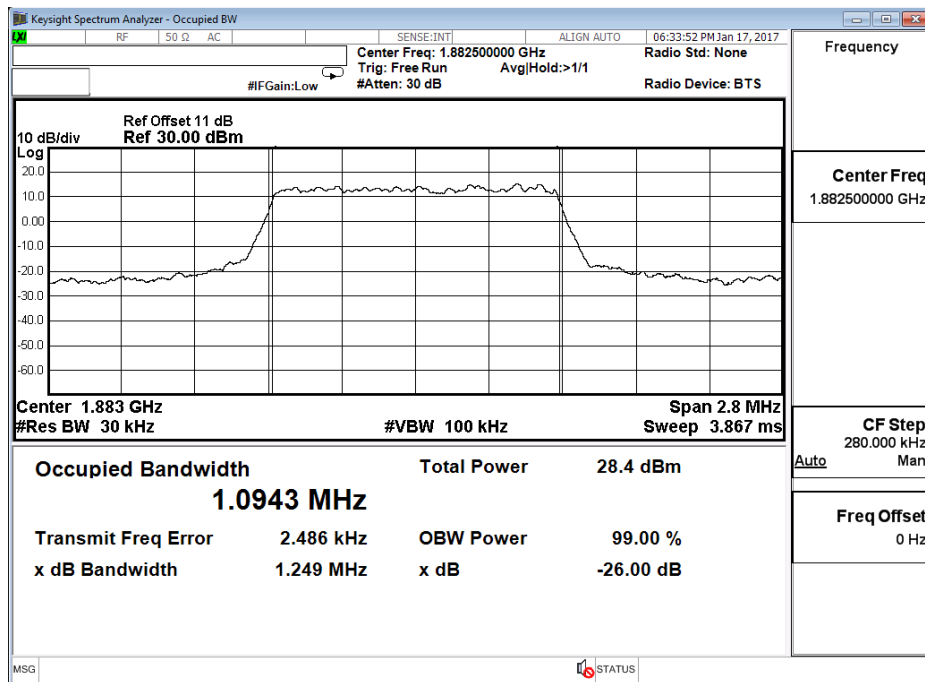

Band 25 1.4M 16QAM - LTE Mode CH26365 (1882.5MHz)

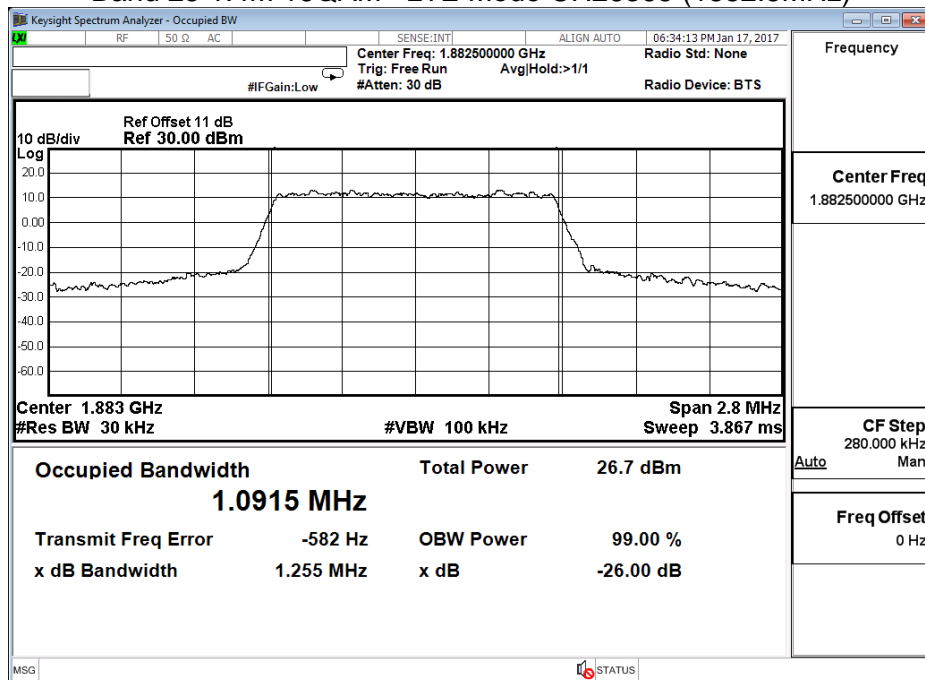

Product	Advanced Industrial 4G/LTE Router, WWAN Failover Manager		
Test Mode	Occupied Bandwidth		
Date of Test	2017/01/17	Test Site	CTR
Test Condition	Band 25 3M		

Band 25 3M QPSK - LTE Mode CH26365 (1882.5MHz)

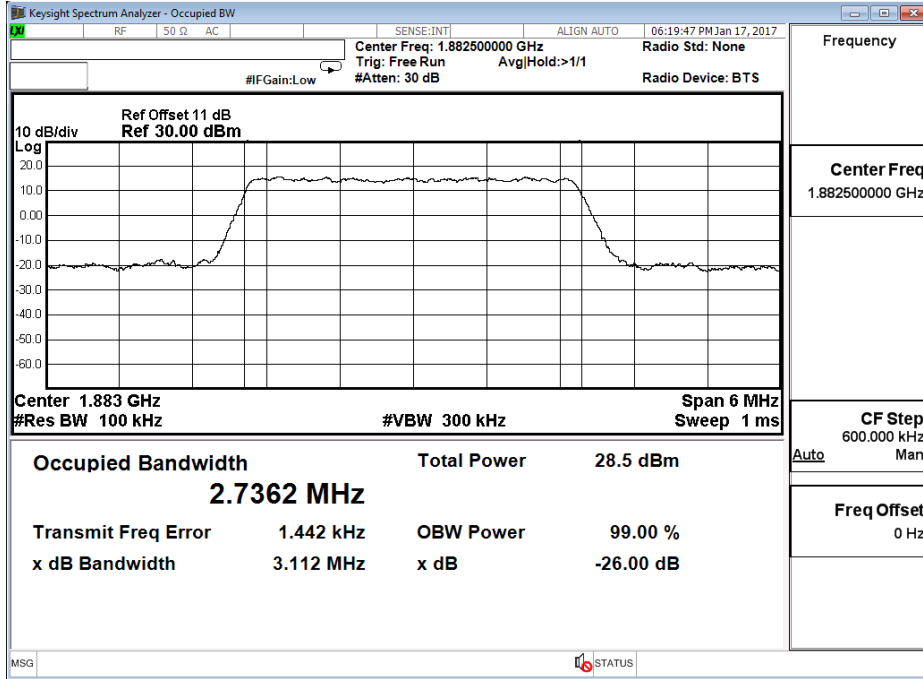

Band 25 3M 16QAM - LTE Mode CH26365 (1882.5MHz)

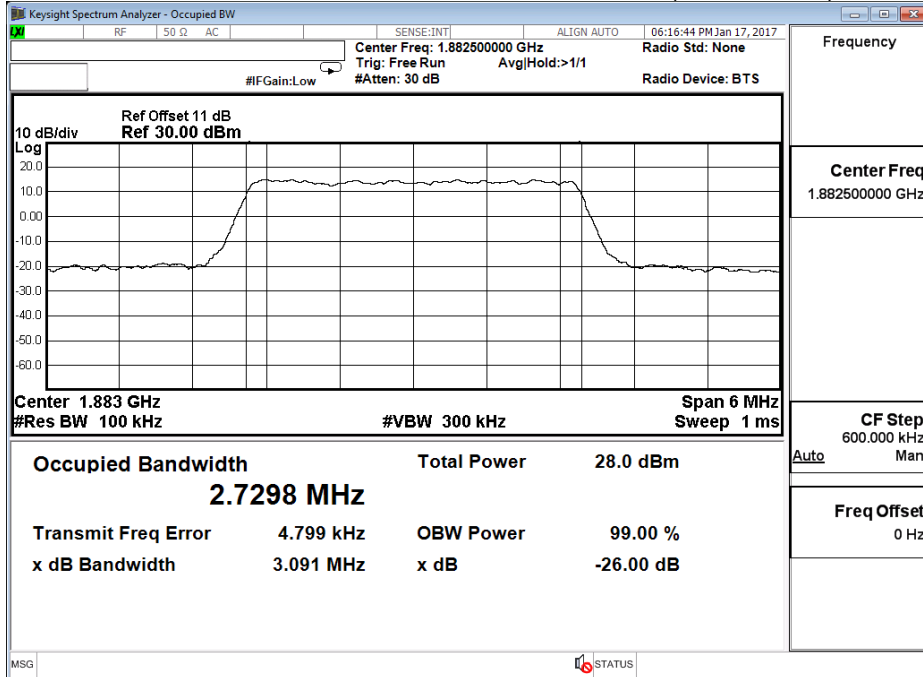

Product	Advanced Industrial 4G/LTE Router, WWAN Failover Manager		
Test Mode	Occupied Bandwidth		
Date of Test	2017/01/17	Test Site	CTR
Test Condition	Band 25 5M		

Band 25 5M QPSK - LTE Mode CH26365 (1882.5MHz)

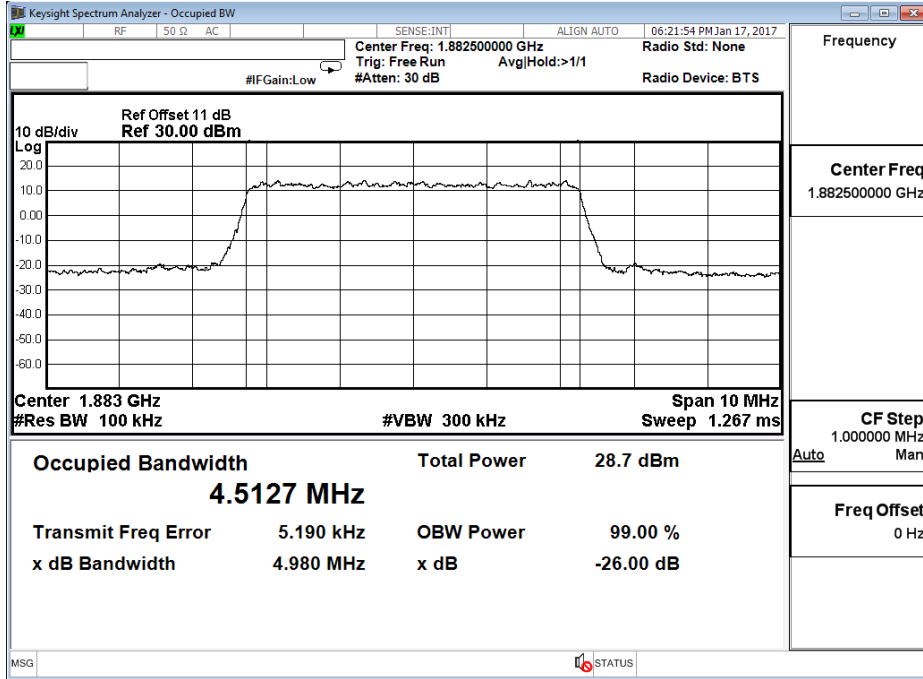

Band 25 5M 16QAM - LTE Mode CH26365 (1882.5MHz)

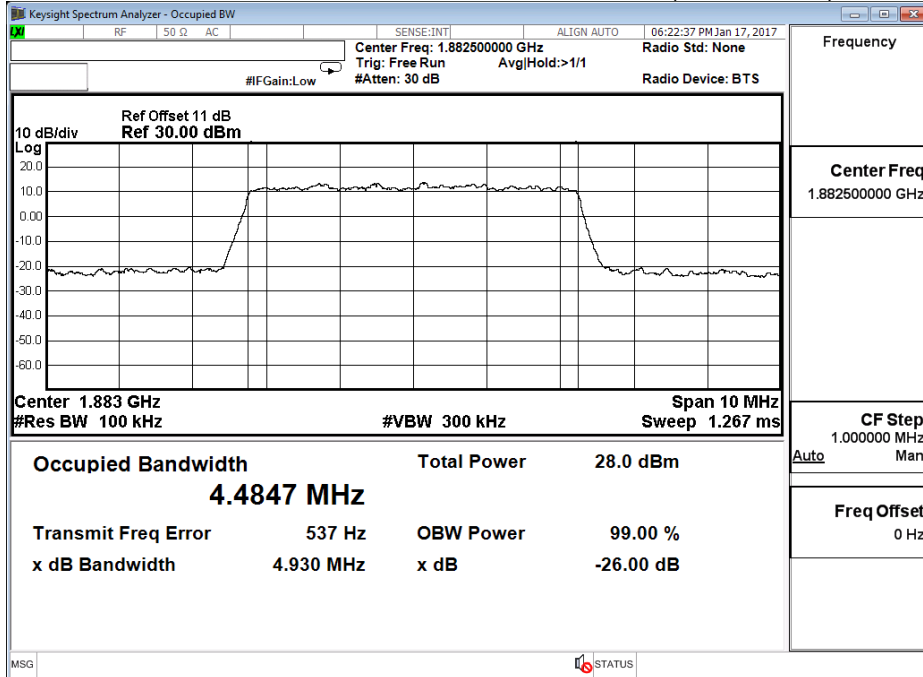

Product	Advanced Industrial 4G/LTE Router, WWAN Failover Manager		
Test Mode	Occupied Bandwidth		
Date of Test	2017/01/17	Test Site	CTR
Test Condition	Band 25 10M		

Band 25 10M QPSK - LTE Mode CH26365 (1882.5MHz)

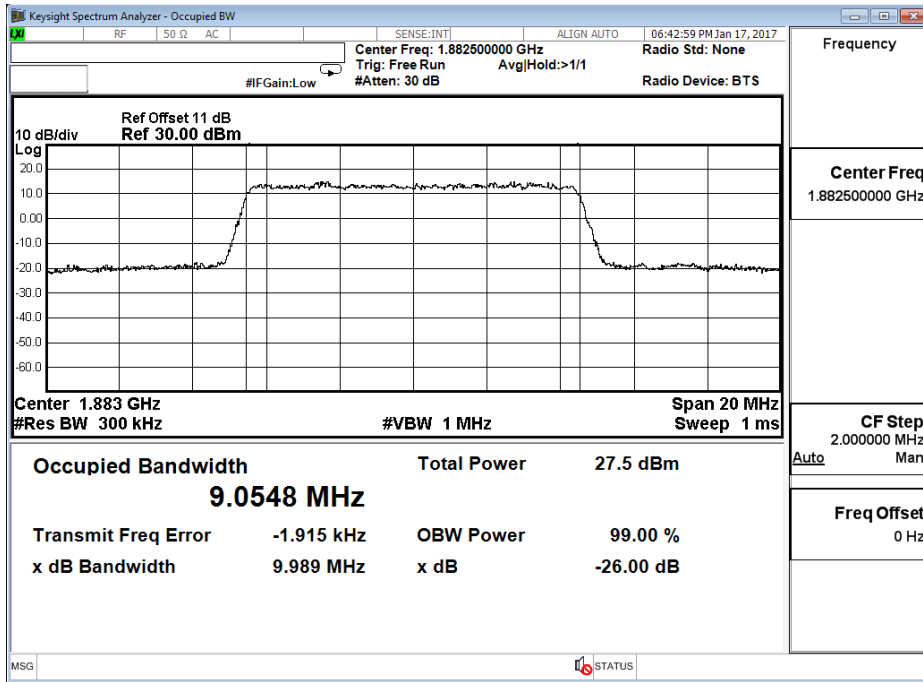

Band 25 10M 16QAM - LTE Mode CH26365 (1882.5MHz)

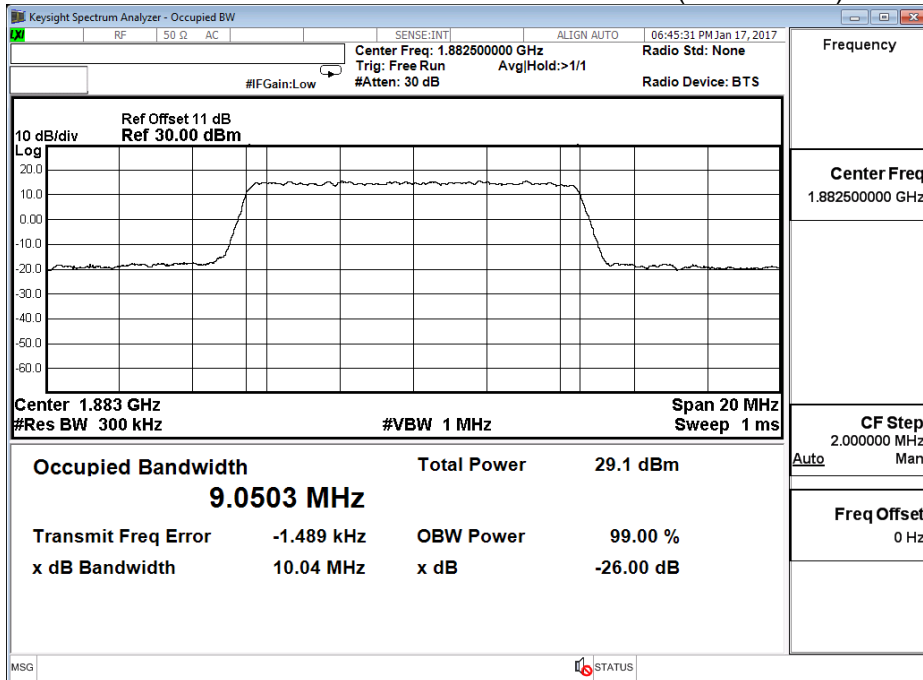

Product	Advanced Industrial 4G/LTE Router, WWAN Failover Manager		
Test Mode	Occupied Bandwidth		
Date of Test	2017/01/17	Test Site	CTR
Test Condition	Band 25 15M		

Band 25 15M QPSK - LTE Mode CH26365 (1882.5MHz)

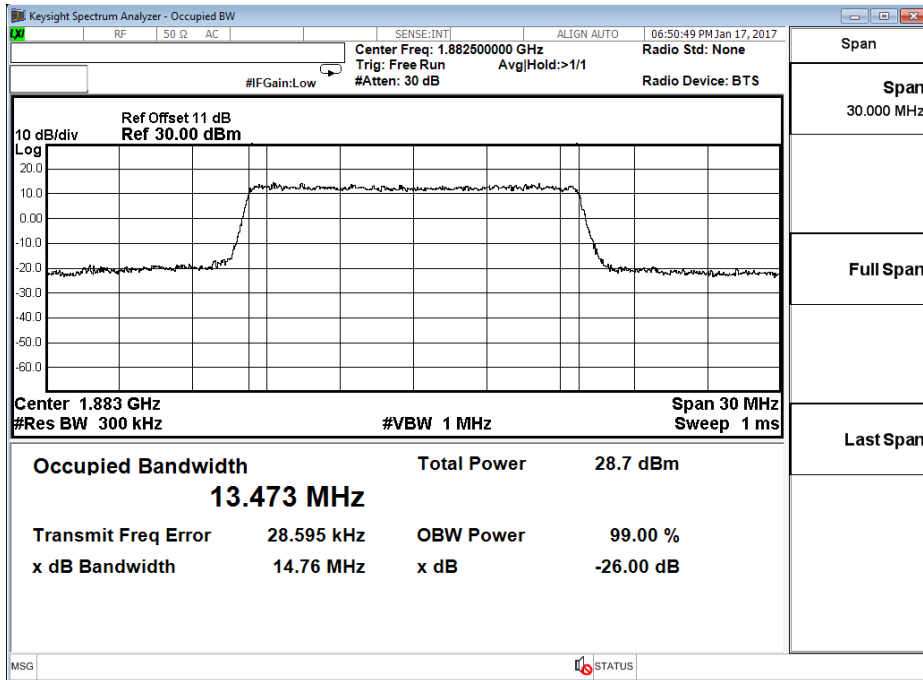

Band 25 15M 16QAM - LTE Mode CH26365 (1882.5MHz)

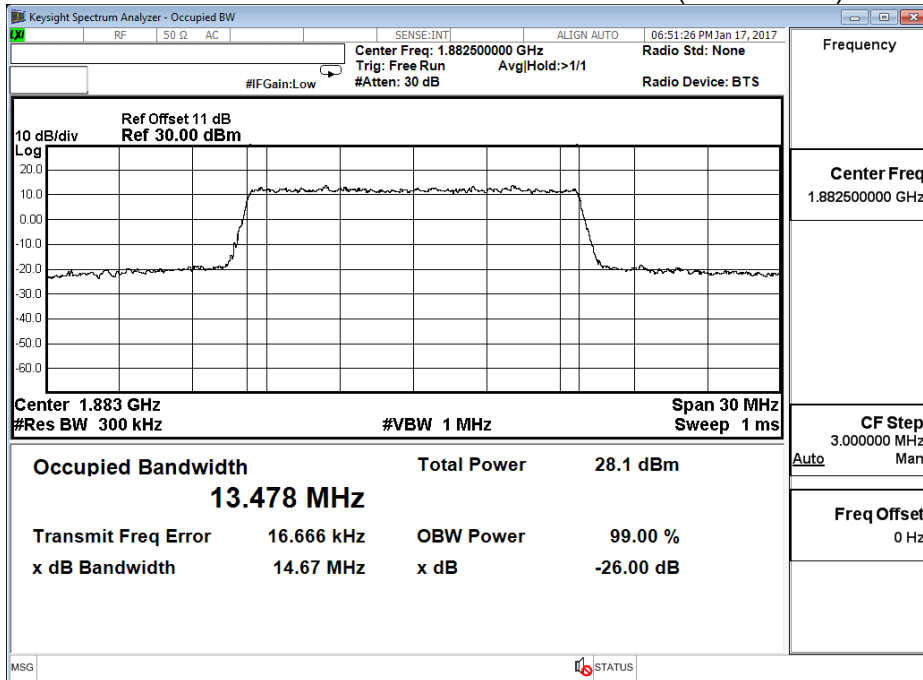

Product	Advanced Industrial 4G/LTE Router, WWAN Failover Manager		
Test Mode	Occupied Bandwidth		
Date of Test	2017/01/17	Test Site	CTR
Test Condition	Band 25 20M		

Band 25 20M QPSK - LTE Mode CH26365 (1882.5MHz)

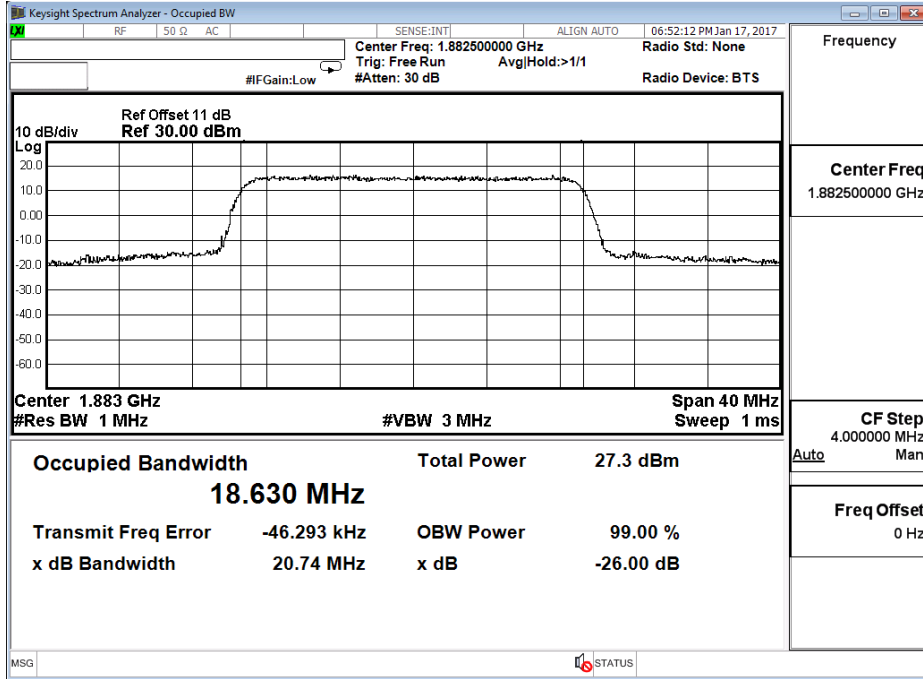

Band 25 20M 16QAM - LTE Mode CH26365 (1882.5MHz)

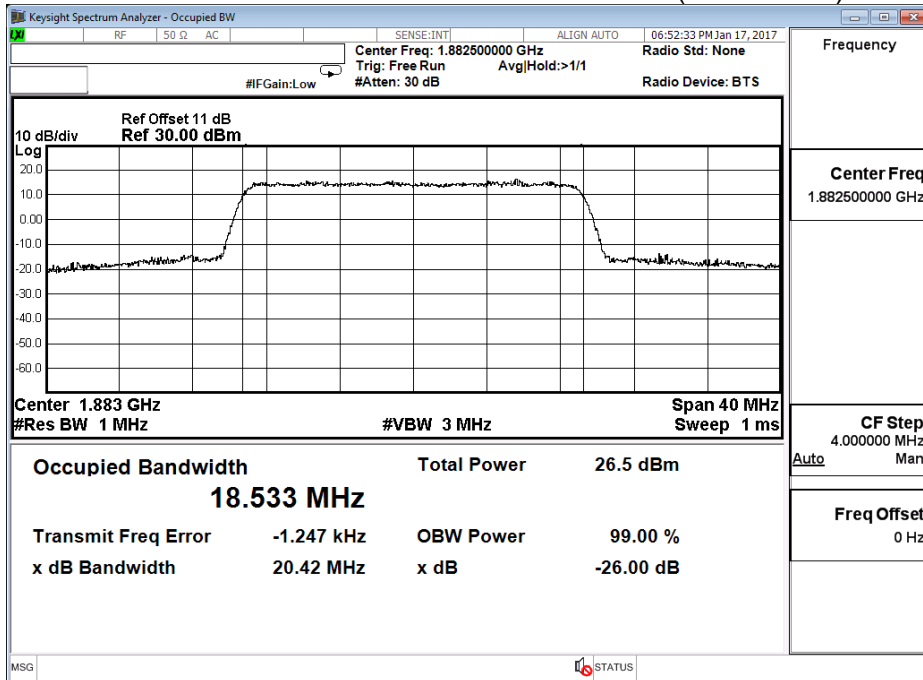

Product	Advanced Industrial 4G/LTE Router, WWAN Failover Manager		
Test Mode	Occupied Bandwidth		
Date of Test	2017/01/17	Test Site	CTR
Test Condition	Band 26 1.4M		

Band 26 1.4M QPSK - LTE Mode CH 26195 (836.5MHz)

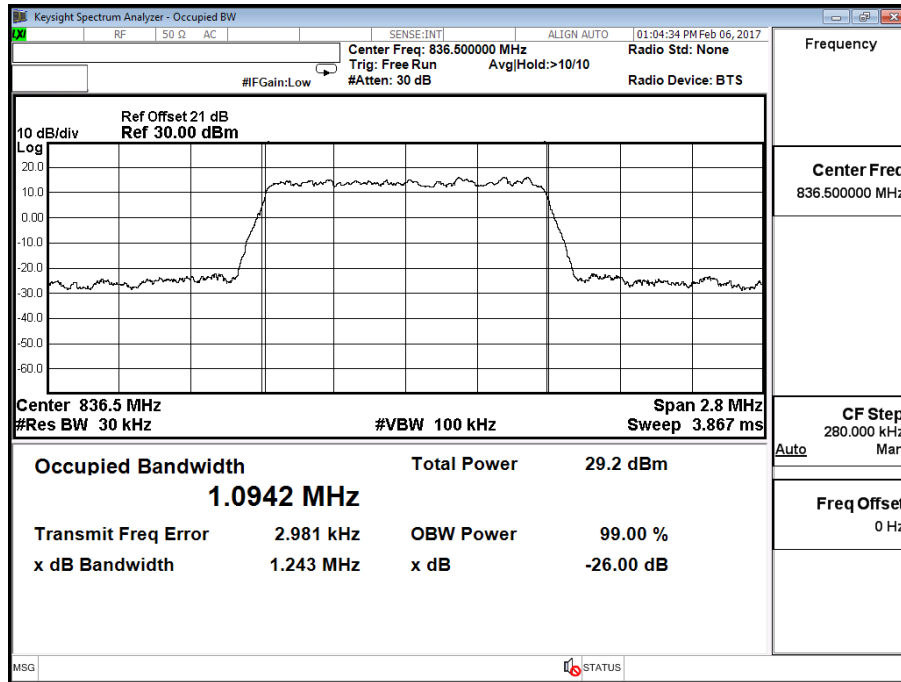

Band 26 1.4M 16QAM - LTE Mode CH 26195 (836.5MHz)

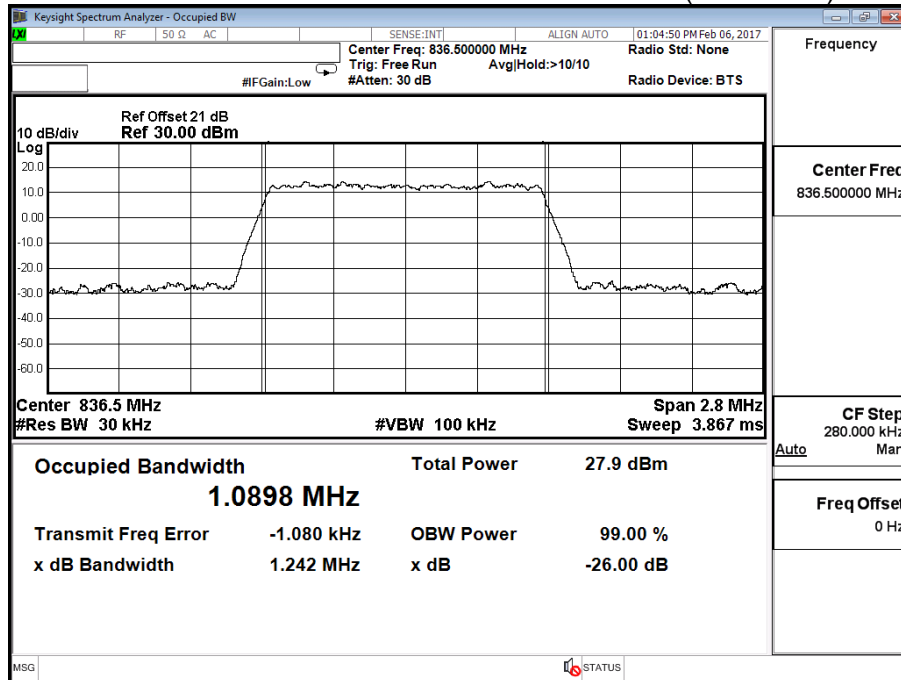

Product	Advanced Industrial 4G/LTE Router, WWAN Failover Manager		
Test Mode	Occupied Bandwidth		
Date of Test	2017/01/17	Test Site	CTR
Test Condition	Band 26 3M		

Band 26 3M QPSK - LTE Mode CH 26195 (836.5MHz)

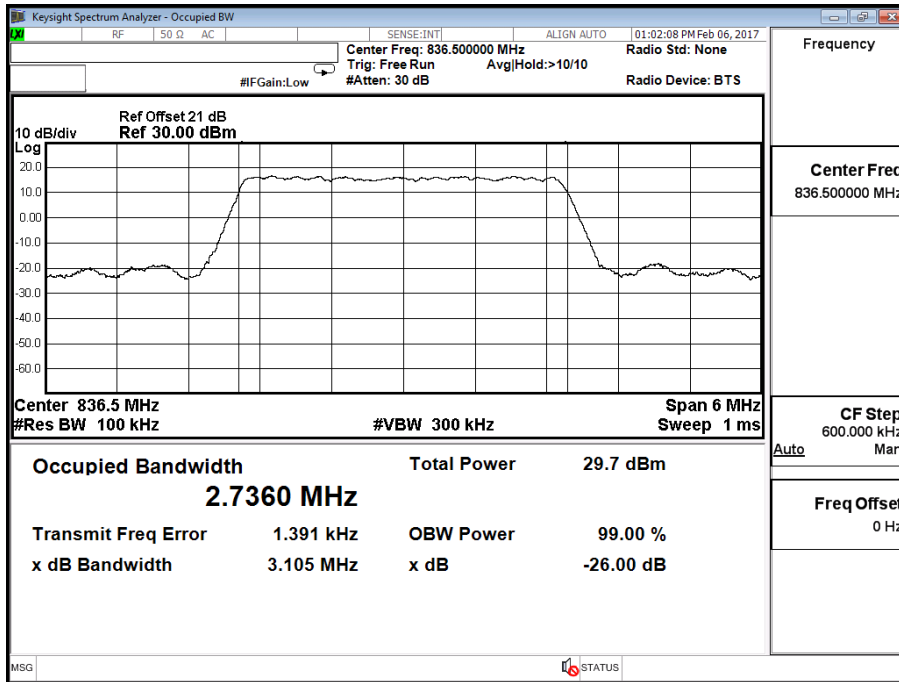

Band 26 3M 16QAM - LTE Mode CH 26195 (836.5MHz)

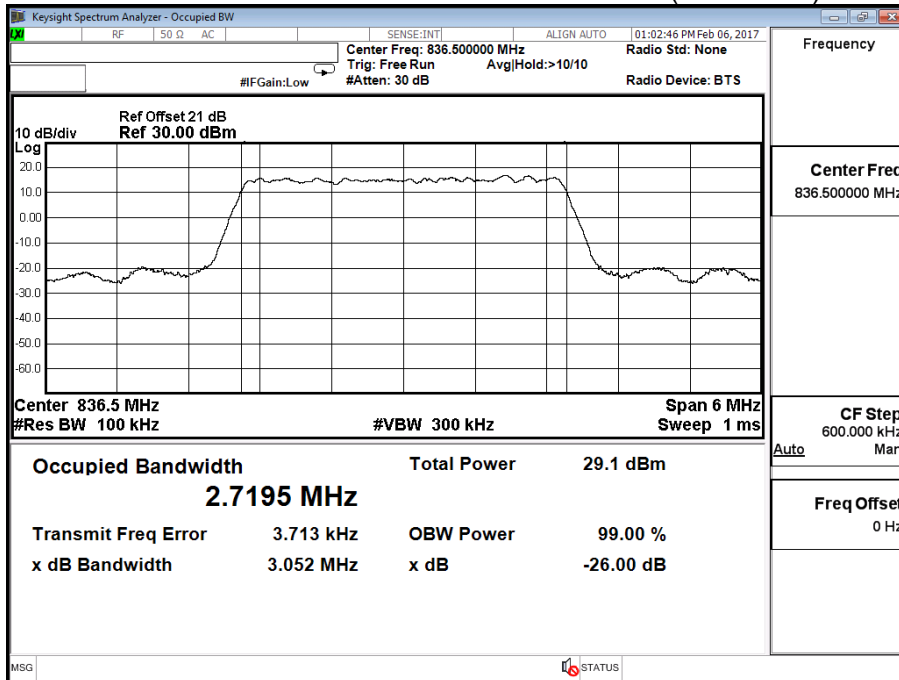

Product	Advanced Industrial 4G/LTE Router, WWAN Failover Manager		
Test Mode	Occupied Bandwidth		
Date of Test	2017/01/17	Test Site	CTR
Test Condition	Band 26 5M		

Band 26 5M QPSK - LTE Mode CH 26195 (836.5MHz)

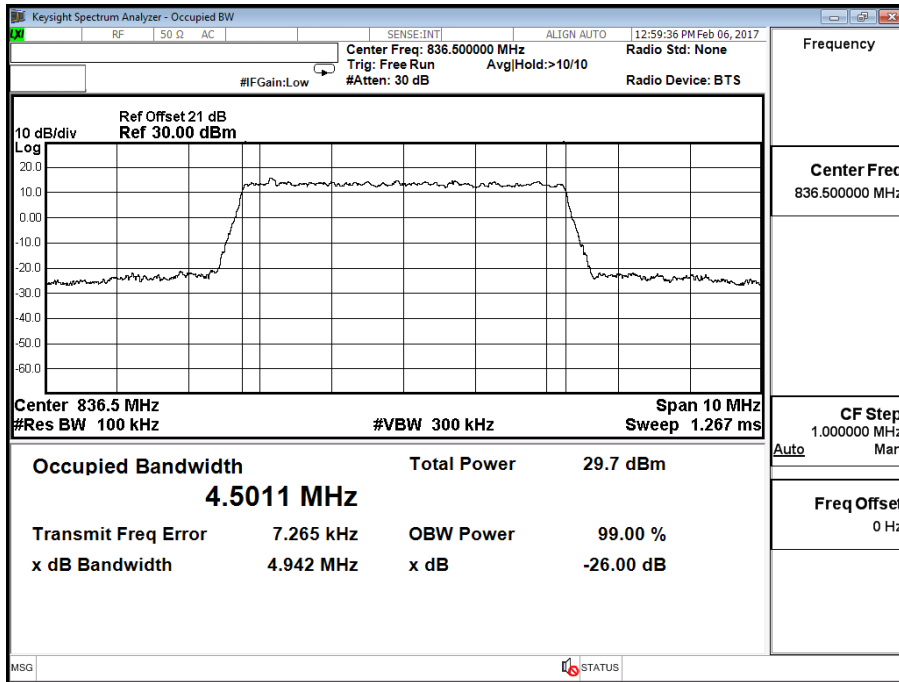

Band 26 5M 16QAM - LTE Mode CH 26195 (836.5MHz)

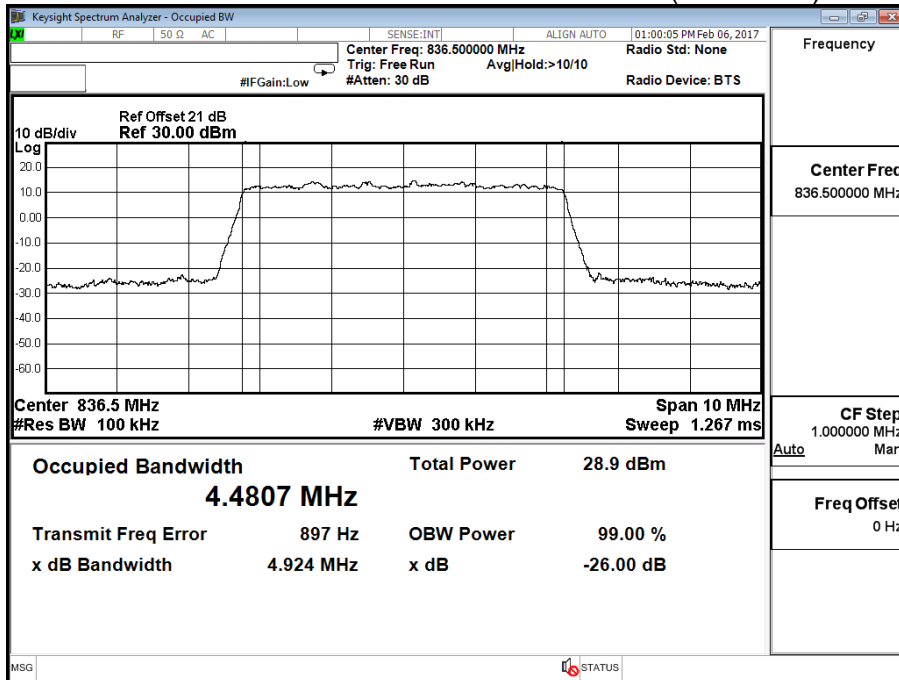

Product	Advanced Industrial 4G/LTE Router, WWAN Failover Manager		
Test Mode	Occupied Bandwidth		
Date of Test	2017/01/17	Test Site	CTR
Test Condition	Band 26 10M		

Band 26 10M QPSK - LTE Mode CH 26195 (836.5MHz)

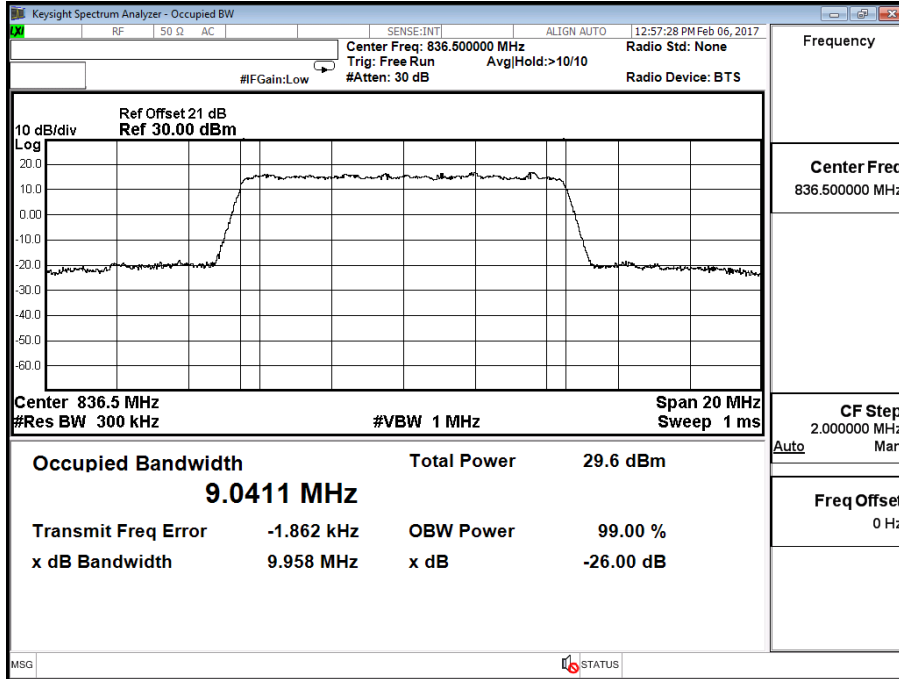

Band 26 10M 16QAM - LTE Mode CH 26195 (836.5MHz)

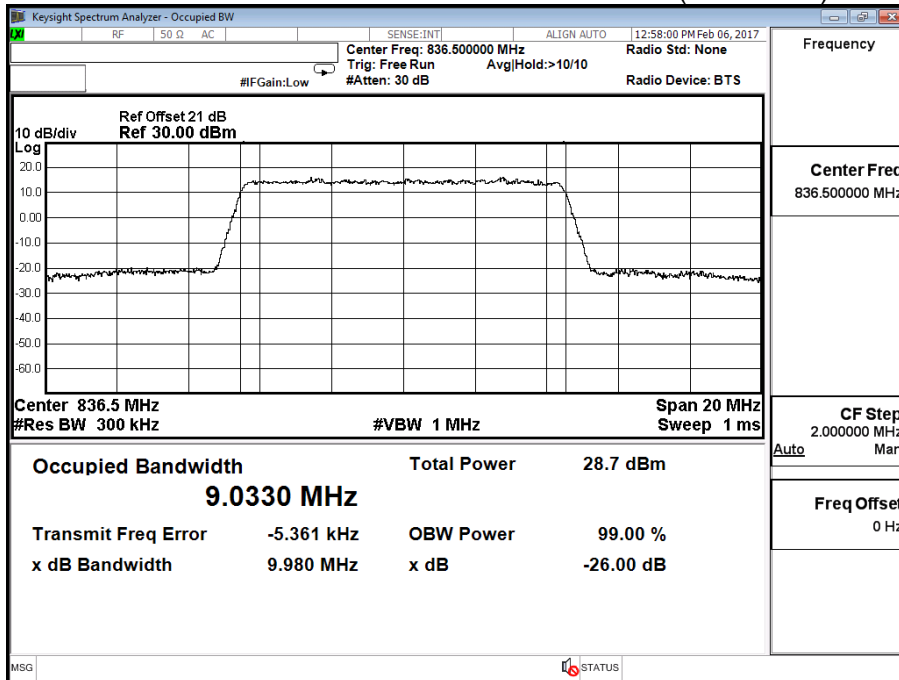

Product	Advanced Industrial 4G/LTE Router, WWAN Failover Manager		
Test Mode	Occupied Bandwidth		
Date of Test	2017/01/17	Test Site	CTR
Test Condition	Band 26 15M		

Band 26 15M QPSK - LTE Mode CH 26195 (836.5MHz)

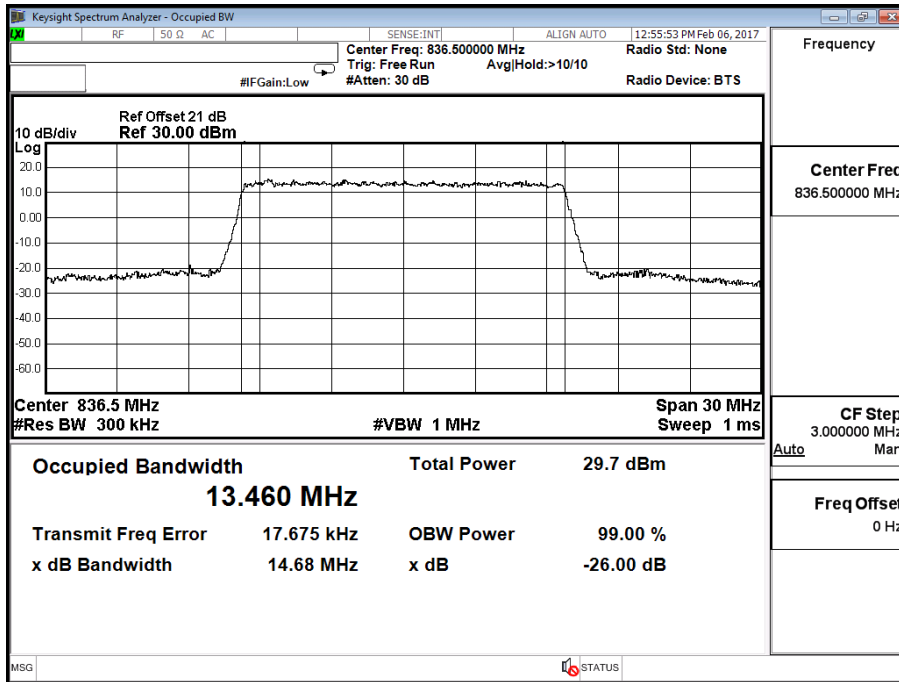

Band 26 15M 16QAM - LTE Mode CH 26195 (836.5MHz)

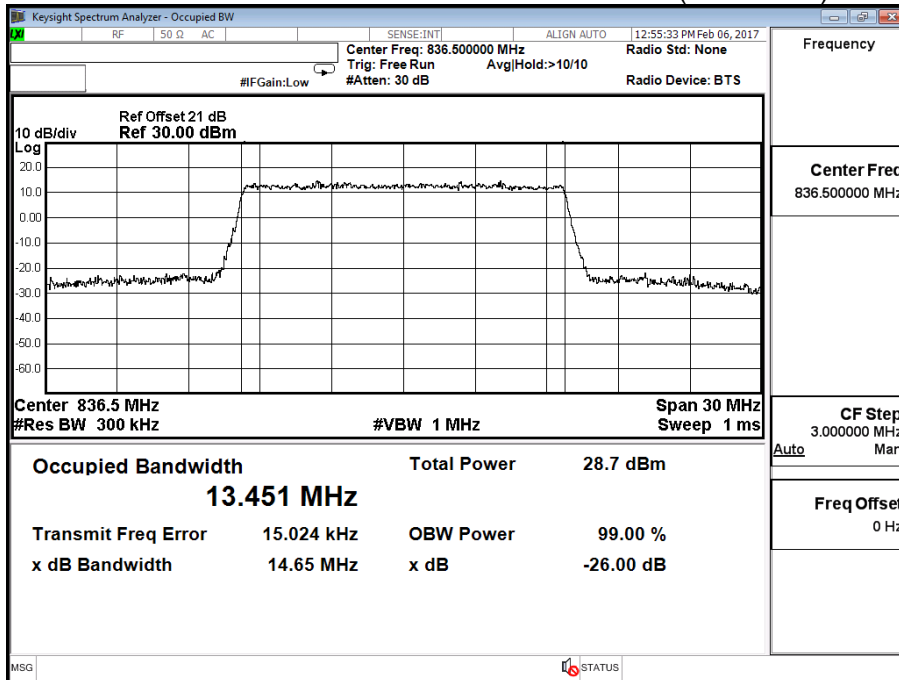

Product	Advanced Industrial 4G/LTE Router, WWAN Failover Manager		
Test Mode	Occupied Bandwidth		
Date of Test	2017/01/17	Test Site	CTR
Test Condition	Band 41 5M		

Band 41 5M QPSK - LTE Mode CH40620 (2593MHz)

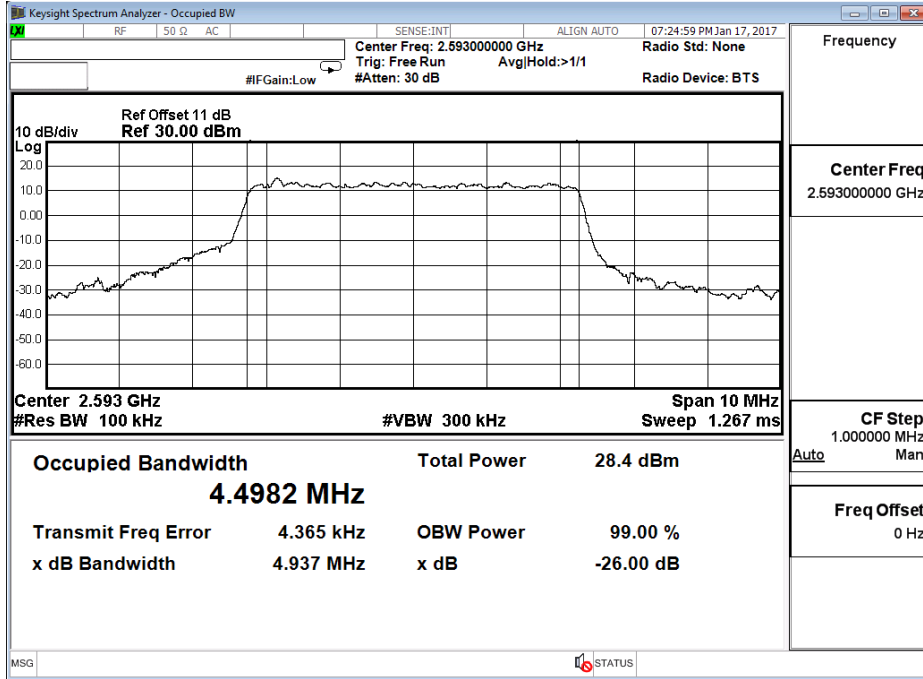

Band 41 5M 16QAM - LTE Mode CH40620 (2593MHz)

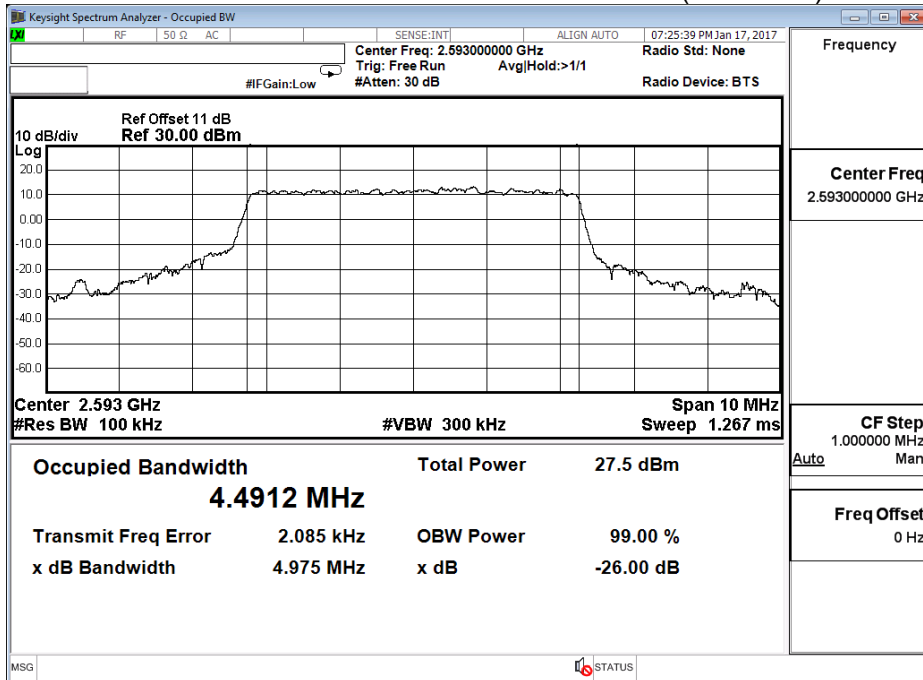

Product	Advanced Industrial 4G/LTE Router, WWAN Failover Manager		
Test Mode	Occupied Bandwidth		
Date of Test	2017/01/17	Test Site	CTR
Test Condition	Band 41 10M		

Band 41 10M QPSK - LTE Mode CH40620 (2593MHz)

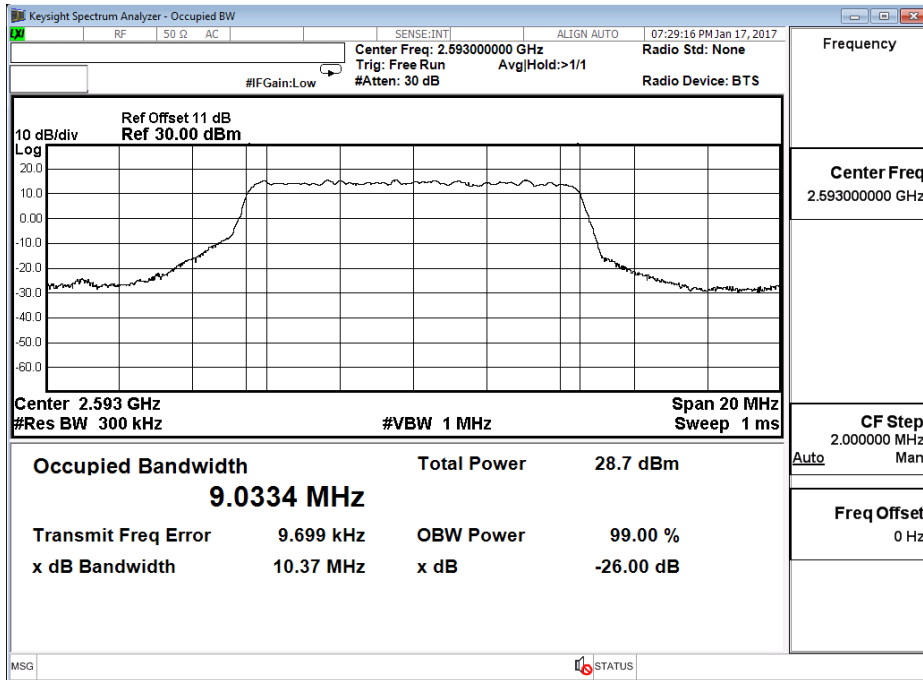

Band 41 10M 16QAM - LTE Mode CH40620 (2593MHz)

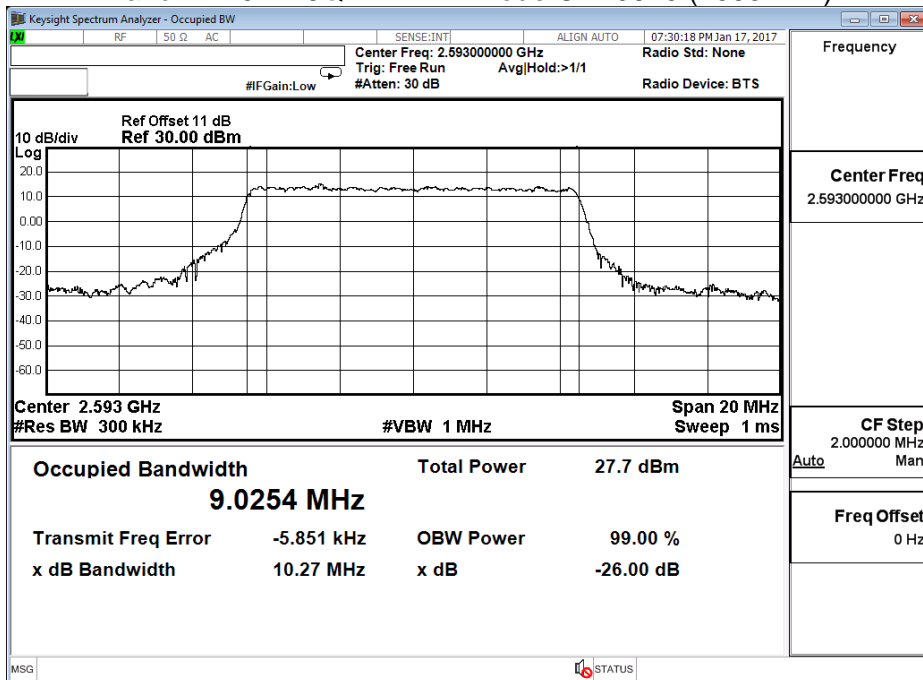

Product	Advanced Industrial 4G/LTE Router, WWAN Failover Manager		
Test Mode	Occupied Bandwidth		
Date of Test	2017/01/17	Test Site	CTR
Test Condition	Band 41 15M		

Band 41 15M QPSK - LTE Mode CH40620 (2593MHz)

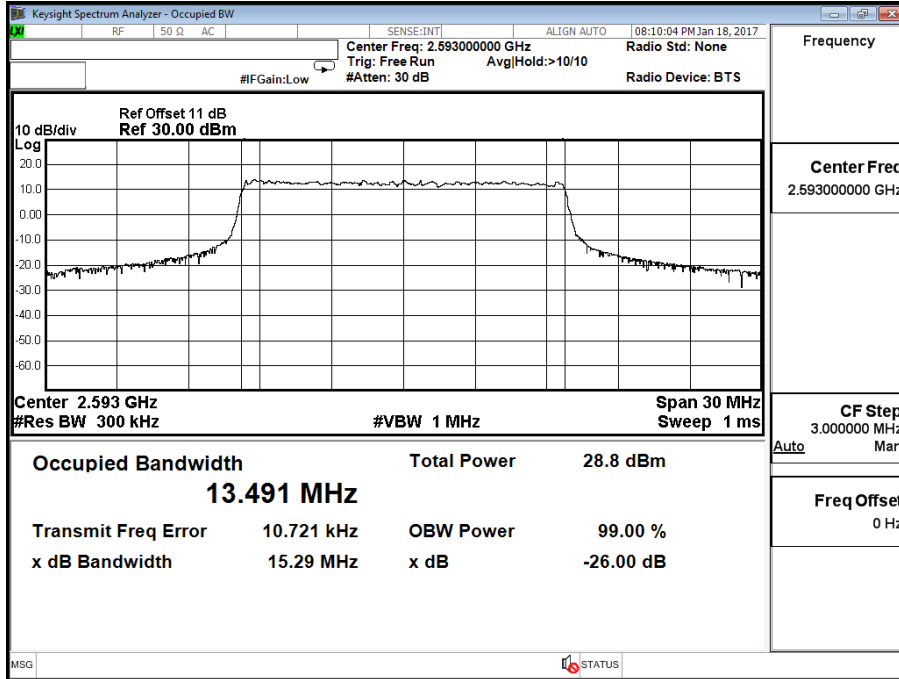

Band 41 15M 16QAM - LTE Mode CH40620 (2593MHz)

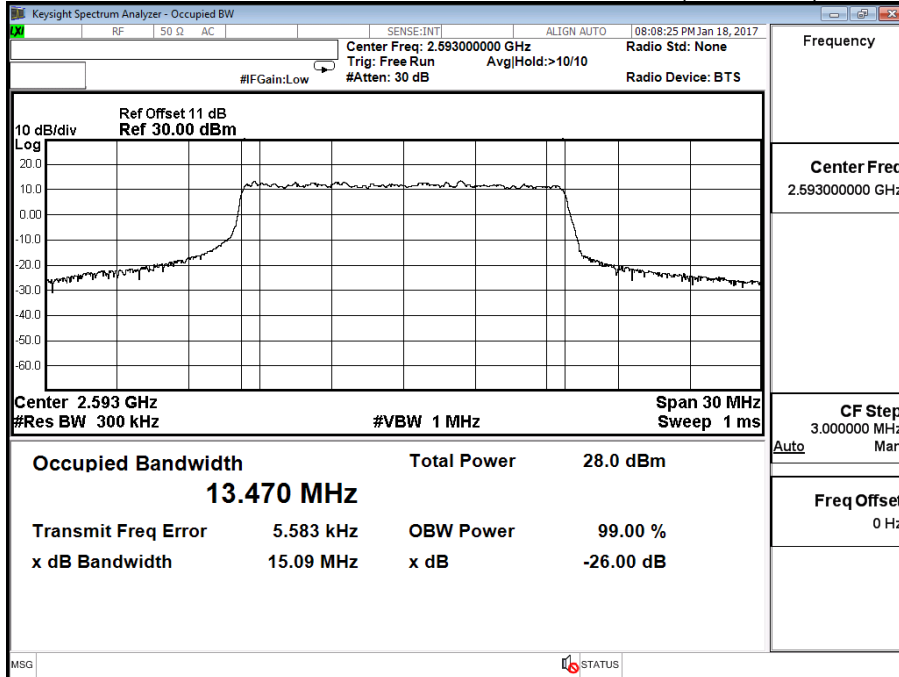

Product	Advanced Industrial 4G/LTE Router, WWAN Failover Manager		
Test Mode	Occupied Bandwidth		
Date of Test	2017/01/17	Test Site	CTR
Test Condition	Band 41 20M		

Band 41 20M QPSK - LTE Mode CH40620 (2593MHz)

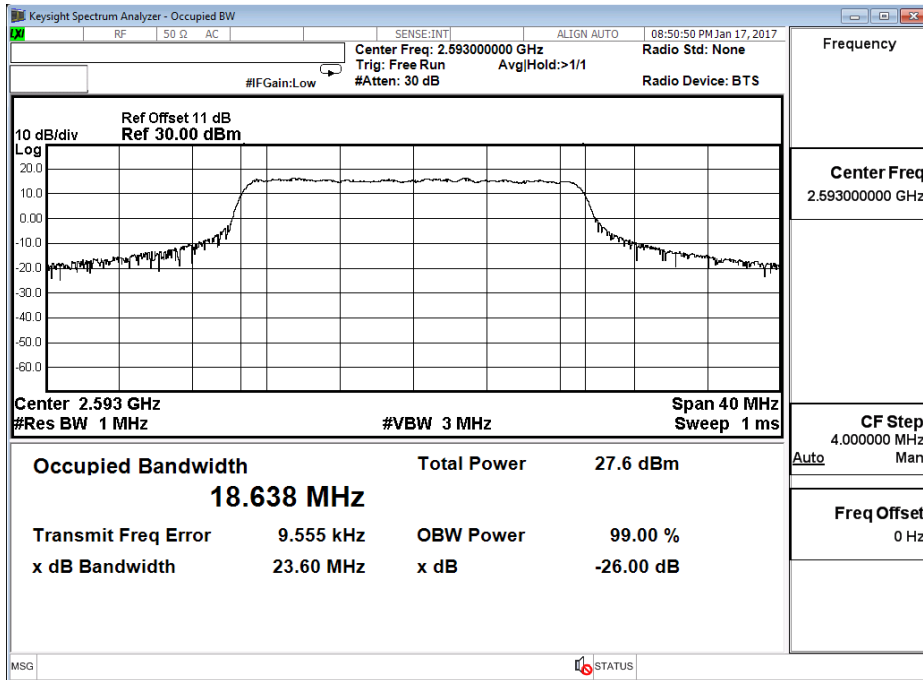

Band 41 20M 16QAM - LTE Mode CH40620 (2593MHz)

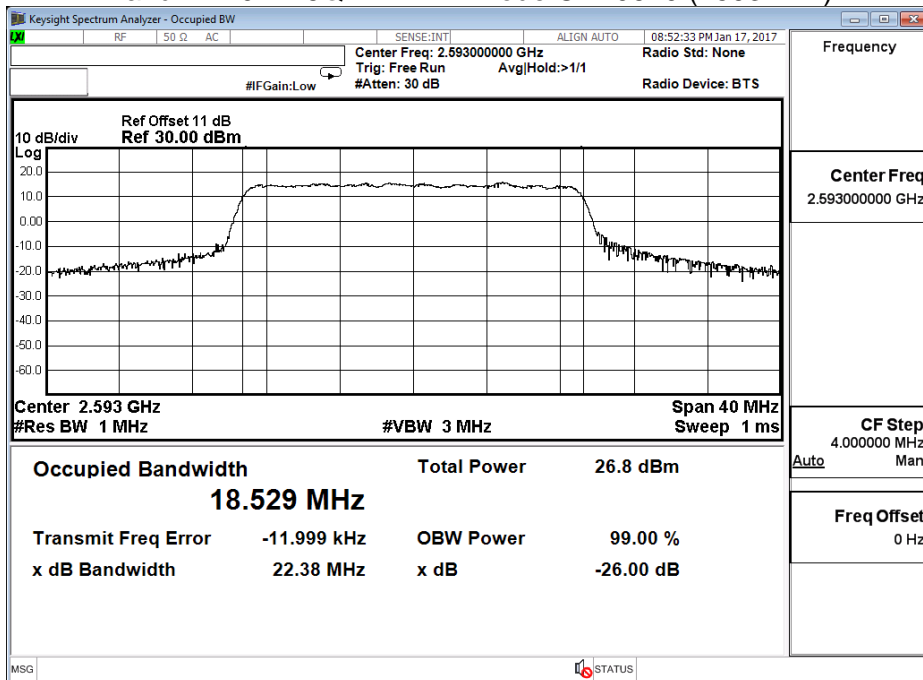

5. Spurious Emission At Antenna Terminals (+/-1MHz)

5.1. Test Specification

According to Part 2.1051, 22.917, 24.238, 27.53

5.2. Setup

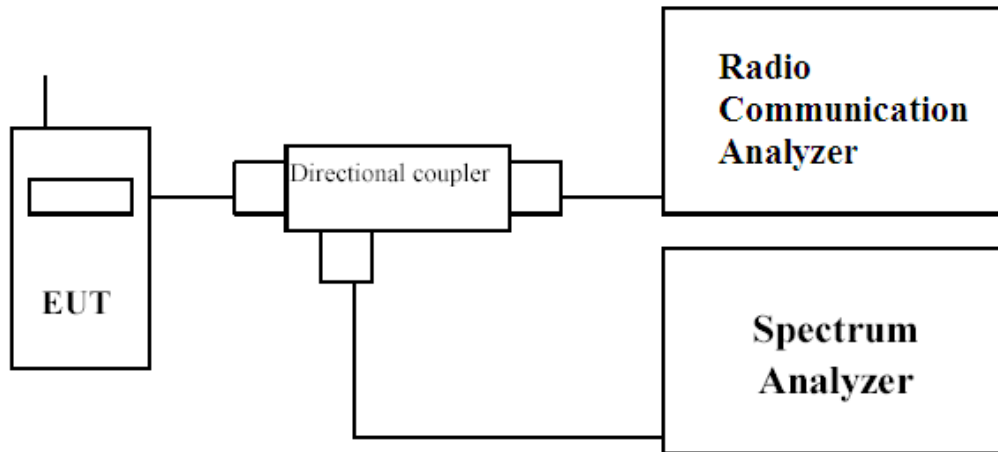

5.3. Limits

The spurious (unwanted) emission limits specified in the individual FCC rule parts applicable to licensed digital transmitters (typically referred to under the heading 'emission limits') normally apply to any and all emissions that are present outside of the authorized frequency band/block and apply to emissions in both the out-of-band and spurious domains. unwanted emissions are required by the licensed rule parts to be attenuated below the transmitter power by a factor of at least $43 + 10 \log(P)$ dB, where P represents the transmitter power expressed in watts

For LTE Band 41:

27.53(m) For mobile digital stations, the attenuation factor shall be not less than $40 + 10 \log(P)$ dB on all frequencies between the channel edge and 5 megahertz from the channel edge, $43 + 10 \log(P)$ dB on all frequencies between 5 megahertz and X megahertz from the channel edge, and $55 + 10 \log(P)$ dB on all frequencies more than X megahertz from the channel edge, where X is the greater of 6 megahertz or the actual emission bandwidth as defined in paragraph (m)(6) of this section. In addition, the attenuation factor shall not be less than $43 + 10 \log(P)$ dB on all frequencies between 2490.5 MHz and 2496 MHz and $55 + 10 \log(P)$ dB at or below 2490.5 MHz. Mobile Satellite Service licensees operating on frequencies below 2495 MHz may also submit a documented interference complaint against BRS licensees operating on channel BRS Channel 1 on the same terms and conditions as adjacent channel BRS or EBS licensees.

5.4. Test Procedure

In accordance with Part 22.917, 24.238, 27.53 at least 1% of the emission bandwidth was used for the resolution and video bandwidths up to 1MHz away from the Block Edge. At greater than 1MHz, the resolution and video bandwidth were increased to 1MHz/3MHz. The reference power and path losses of all channels used for testing in each frequency block were measured.

5.5. Test Result of Spurious Emission At Antenna Terminals (+/-1MHz)

Product	Advanced Industrial 4G/LTE Router, WWAN Failover Manager		
Test Mode	Spurious Emission At Antenna Terminals (+/-1MHz)		
Date of Test	2017/01/18	Test Site	CTR
Test Condition	Block Edge Test (Band 25 (1.4M))		

Band 25 (1.4M) QPSK (1,0) Lower Channel 26047 (1850.7MHz)

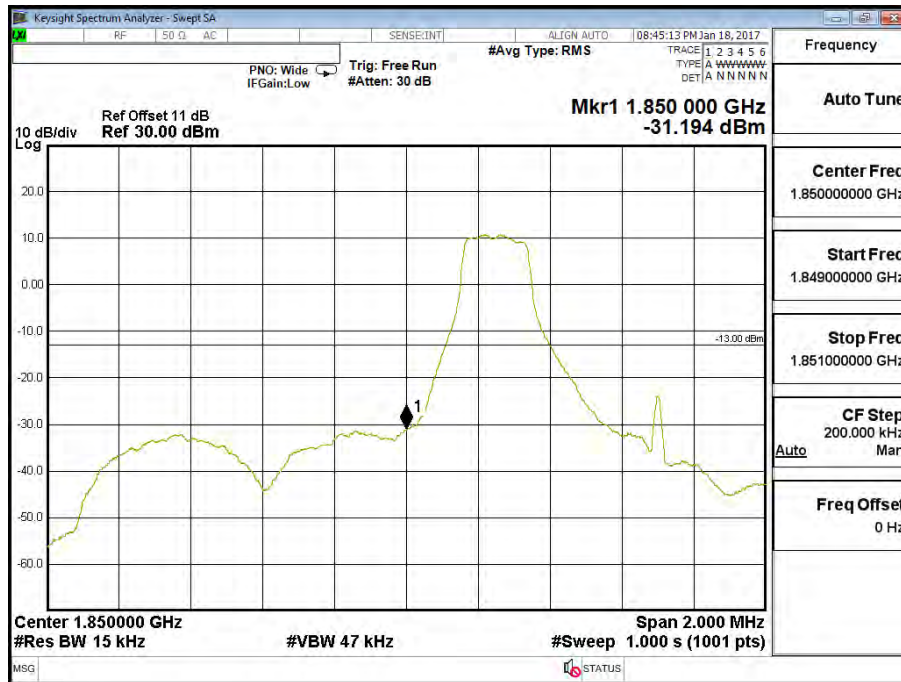

Band 25 (1.4M) QPSK (1,5) Upper Channel 26683 (1914.3MHz)

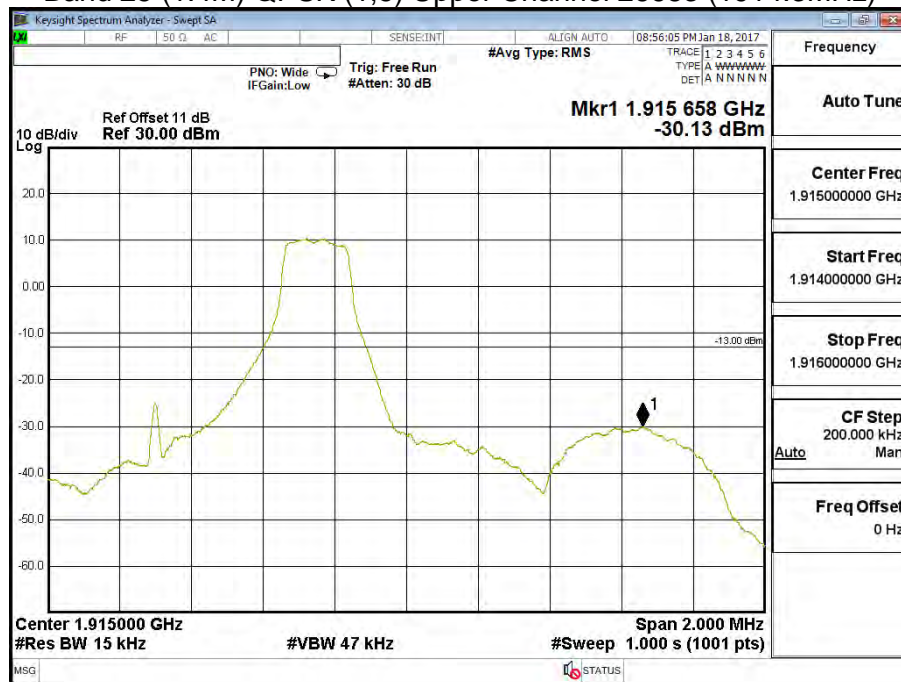

Band 25 (1.4M) QPSK (6,0) Lower Channel 26047 (1850.7MHz)

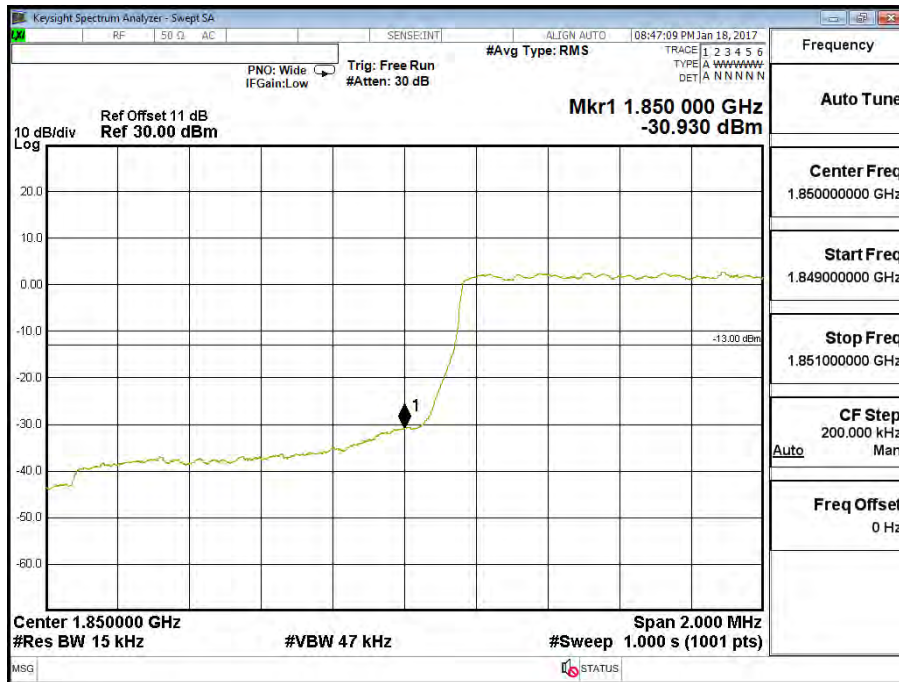

Band 25 (1.4M) QPSK (6,0) Upper Channel 26683 (1914.3MHz)

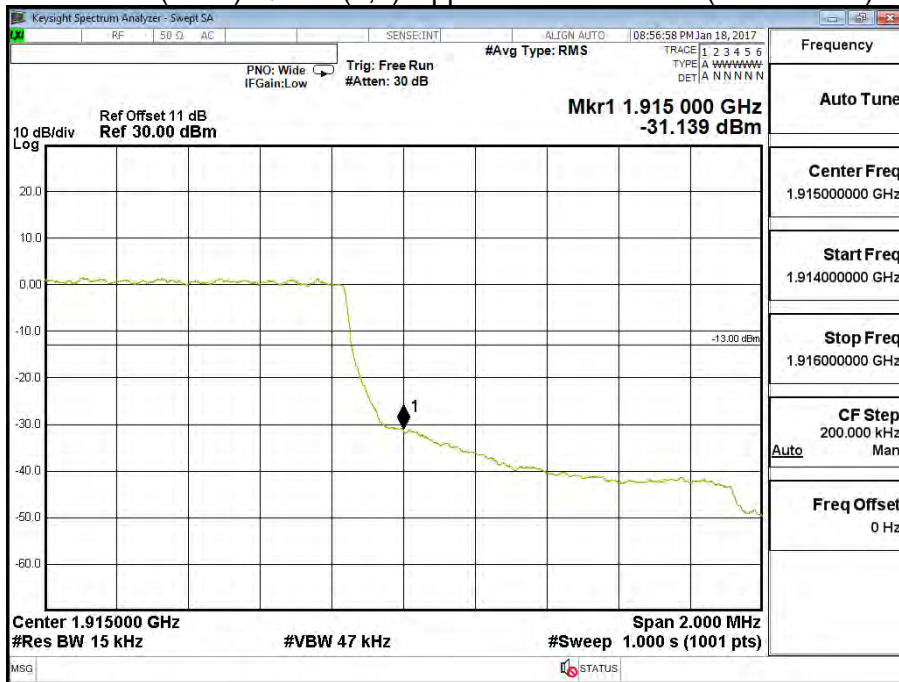

Band 25 (1.4M) 16QAM (1,0) Lower Channel 26047 (1850.7MHz)

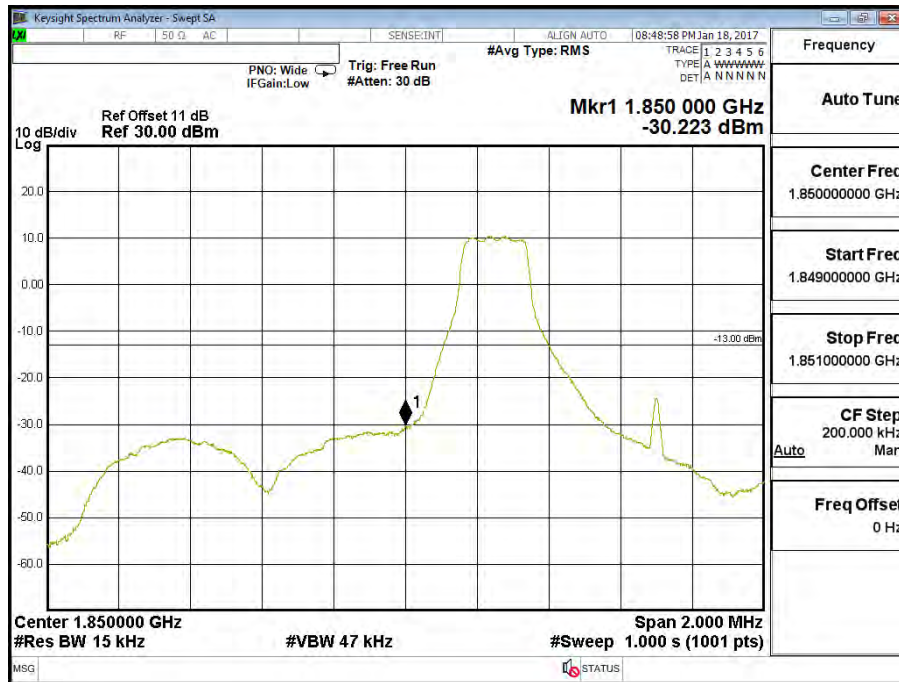

Band 25 (1.4M) 16QAM (1,5) Upper Channel 26683 (1914.3MHz)

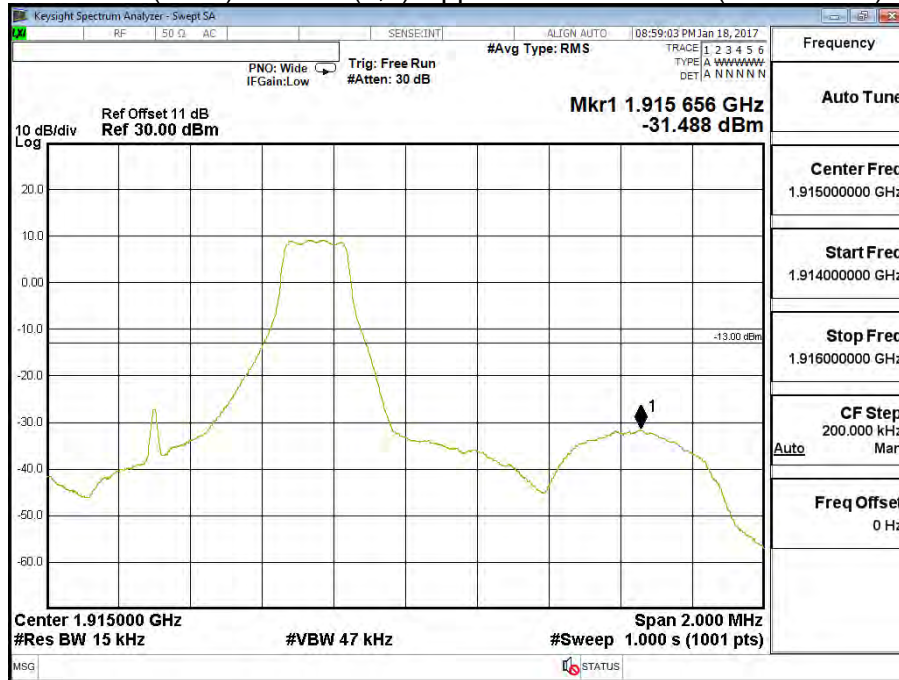

Band 25 (1.4M) 16QAM (6,0) Lower Channel 26047 (1850.7MHz)

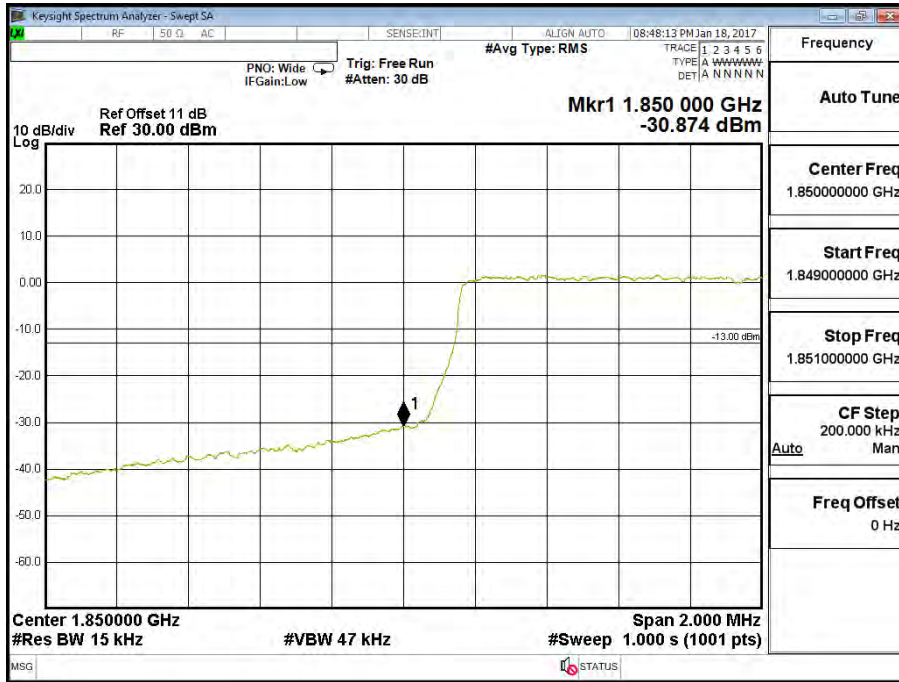

Band 25 (1.4M) 16QAM (6,0) Upper Channel 26683 (1914.3MHz)

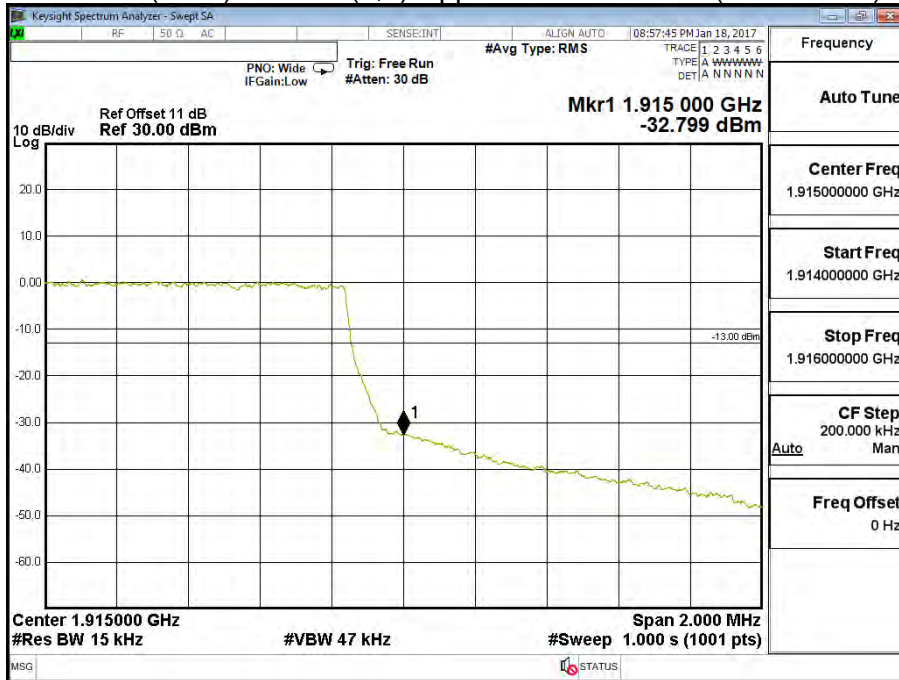

Product	Advanced Industrial 4G/LTE Router, WWAN Failover Manager		
Test Mode	Spurious Emission At Antenna Terminals (+/-1MHz)		
Date of Test	2017/01/18	Test Site	CTR
Test Condition	Block Edge Test (Band 25 (3M))		

Band 25 (3M) QPSK (1,0) Lower Channel 26055 (1851.5MHz)

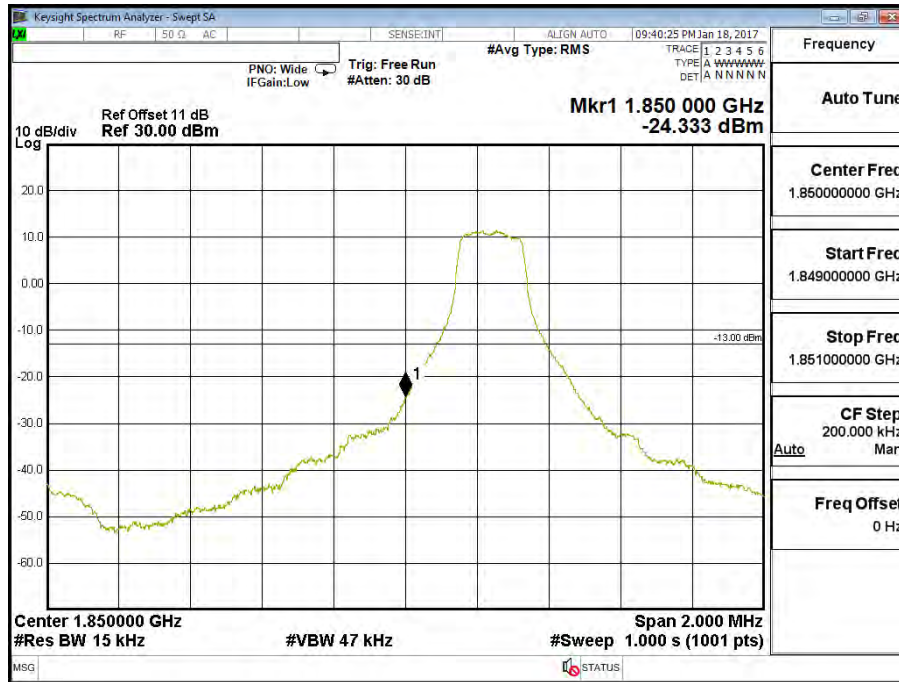

Band 25 (3M) QPSK (1,14) Upper Channel 26675 (1913.5MHz)

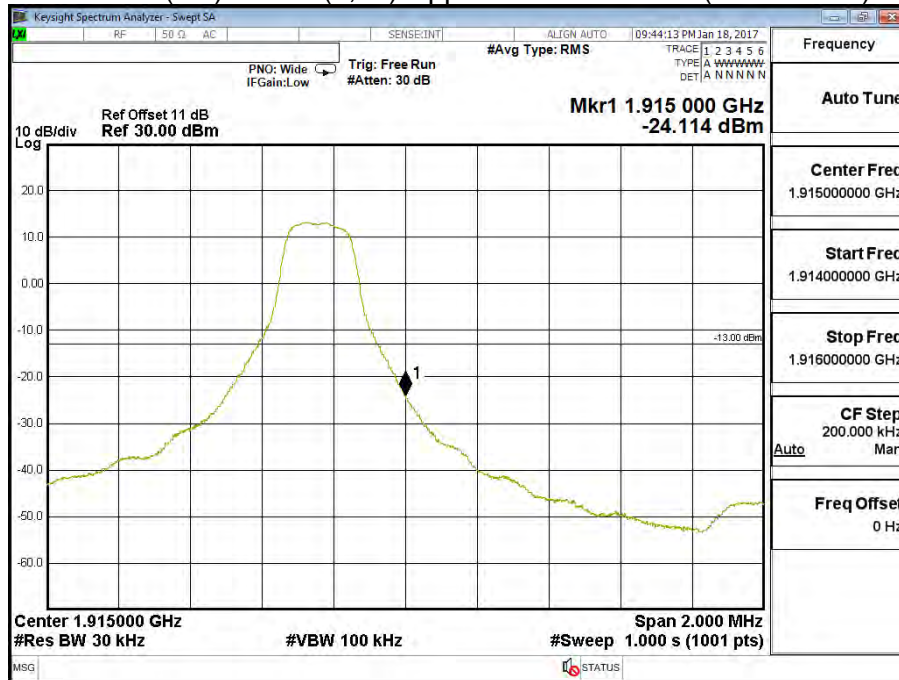

Band 25 (3M) QPSK (15,0) Lower Channel 26055 (1851.5MHz)

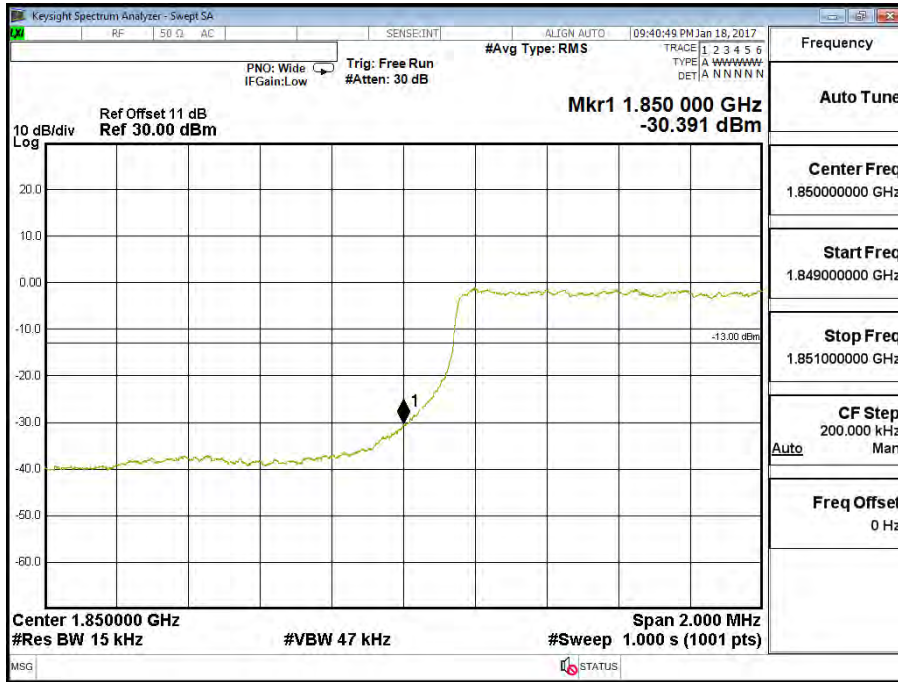

Band 25 (3M) QPSK (15,0) Upper Channel 26675 (1913.5MHz)

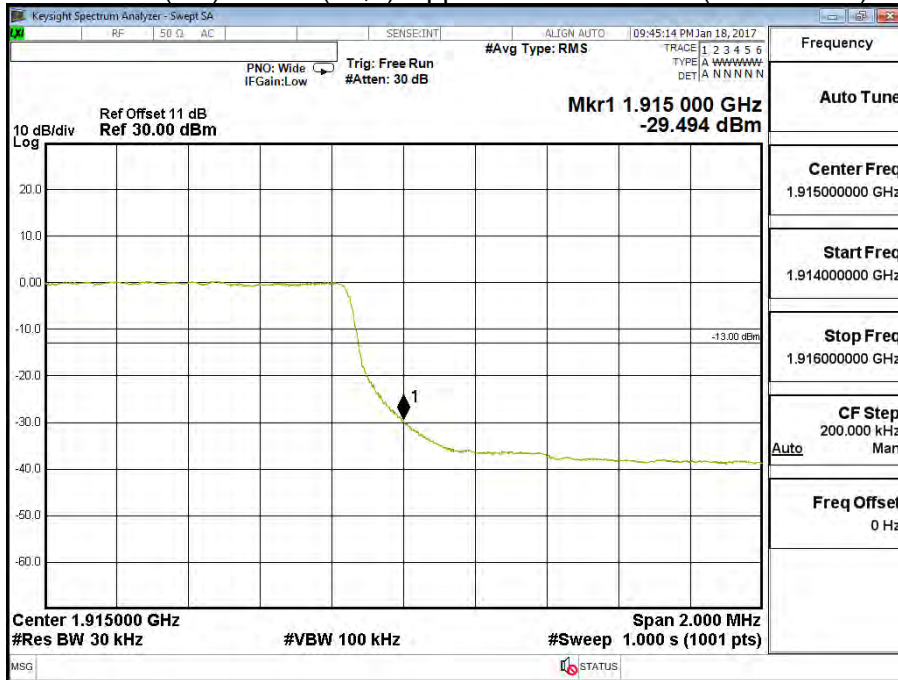

Band 25 (3M) 16QAM (1,0) Lower Channel 26055 (1851.5MHz)

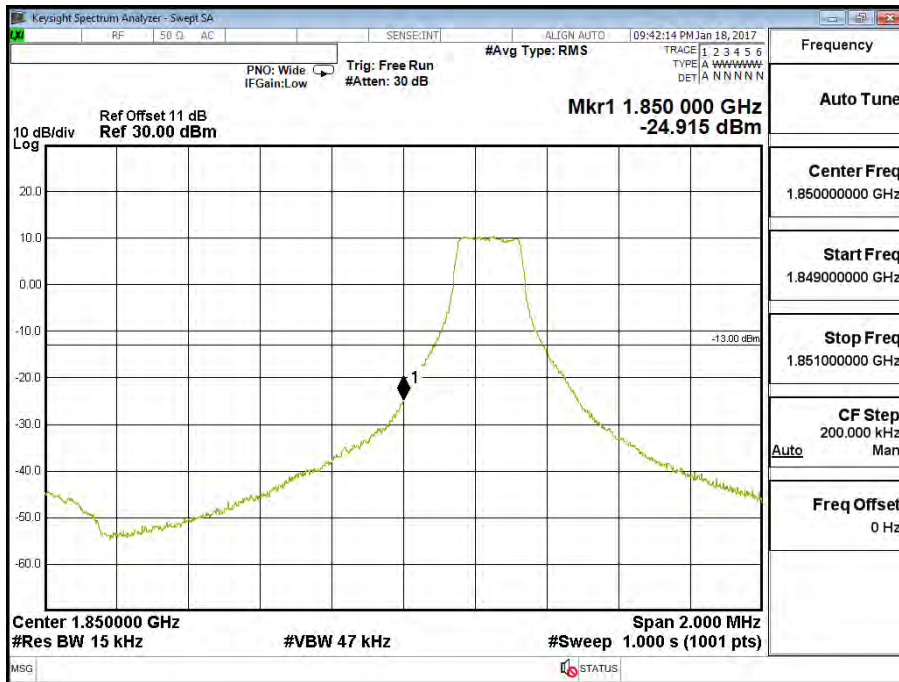

Band 25 (3M) 16QAM (1,14) Upper Channel 26675 (1913.5MHz)

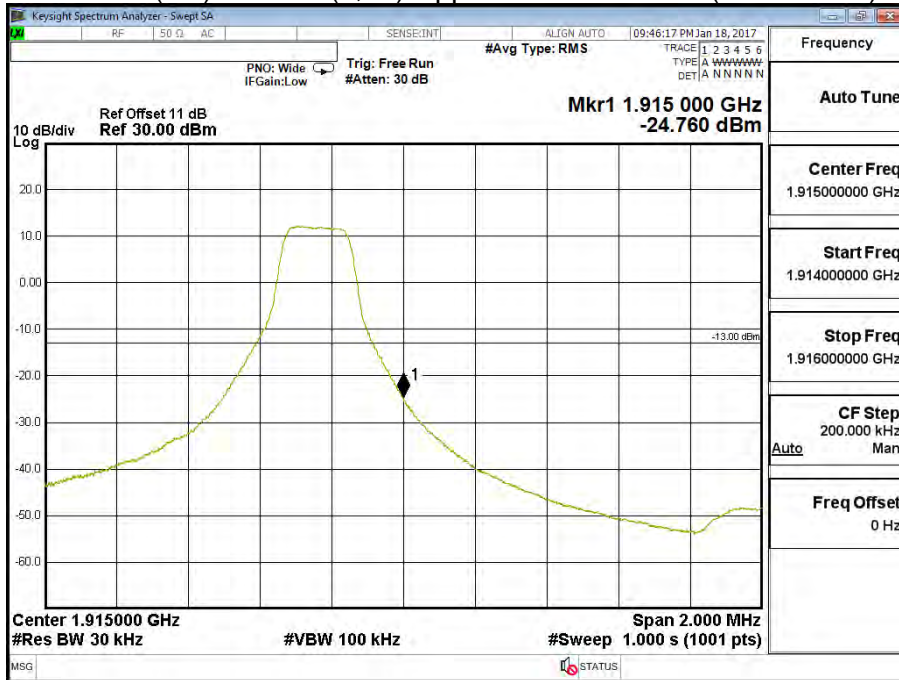

Band 25 (3M) 16QAM (15,0) Lower Channel 26055 (1851.5MHz)

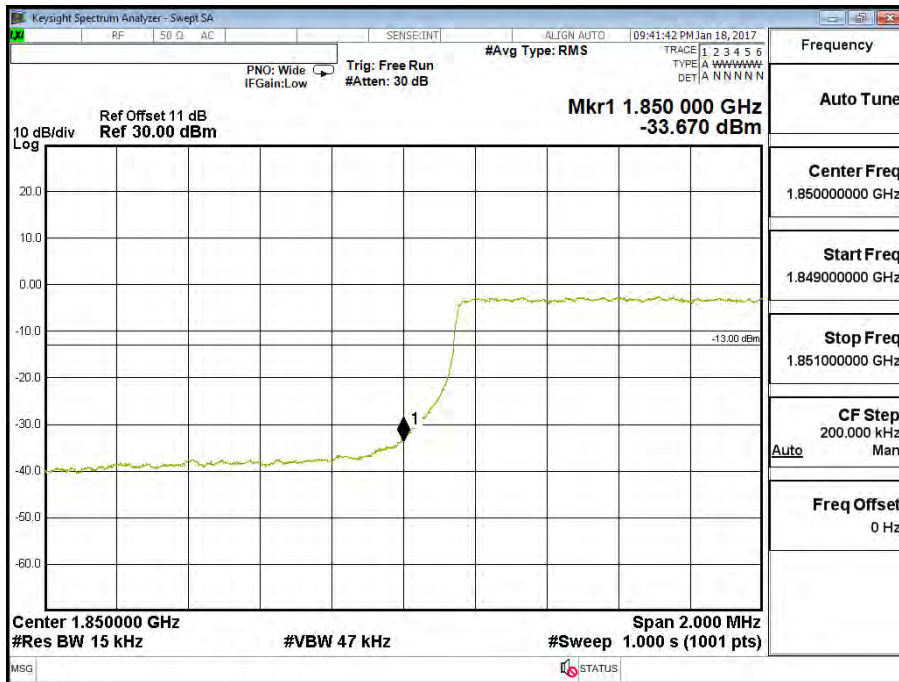

Band 25 (3M) 16QAM (15,0) Upper Channel 26675 (1913.5MHz)

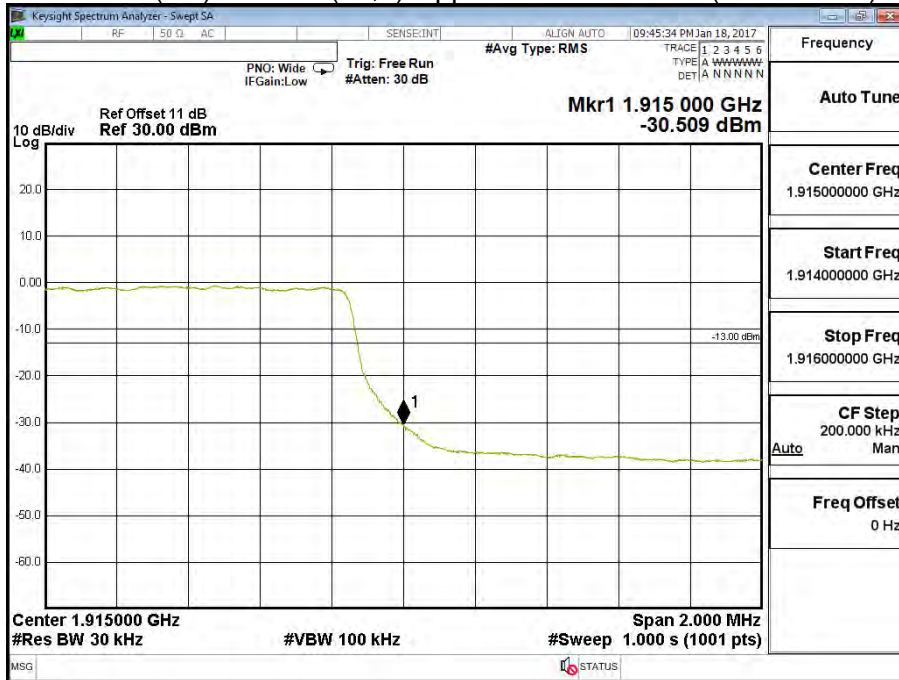

Product	Advanced Industrial 4G/LTE Router, WWAN Failover Manager		
Test Mode	Spurious Emission At Antenna Terminals (+/-1MHz)		
Date of Test	2017/01/18	Test Site	CTR
Test Condition	Block Edge Test (Band 25 (5M))		

Band 25 (5M) QPSK(1,0) Lower Channel 26065 (1852.5MHz)

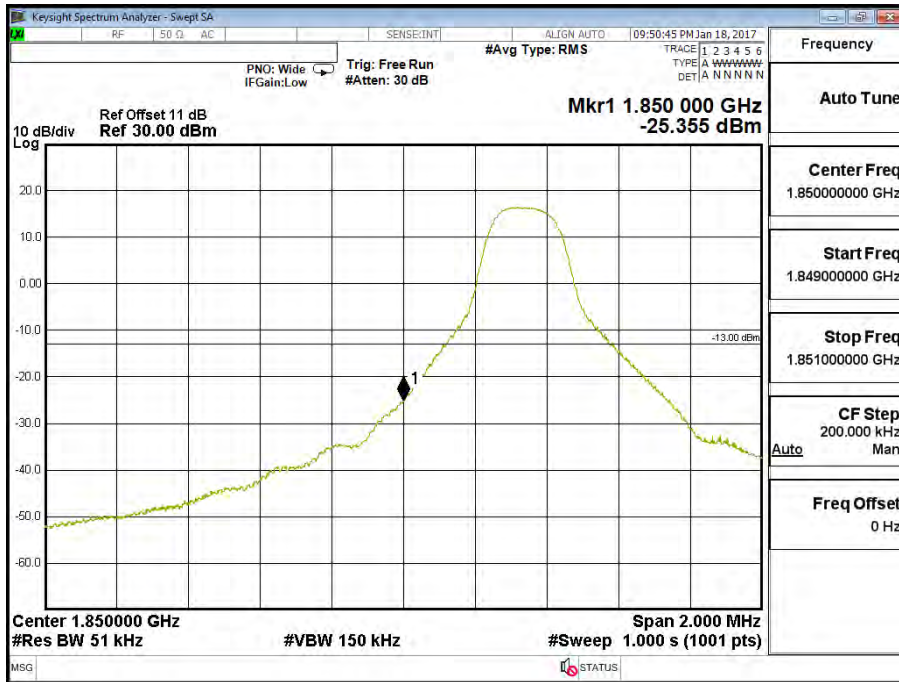

Band 25 (5M) QPSK(1,24) Upper Channel 26665 (1912.5MHz)

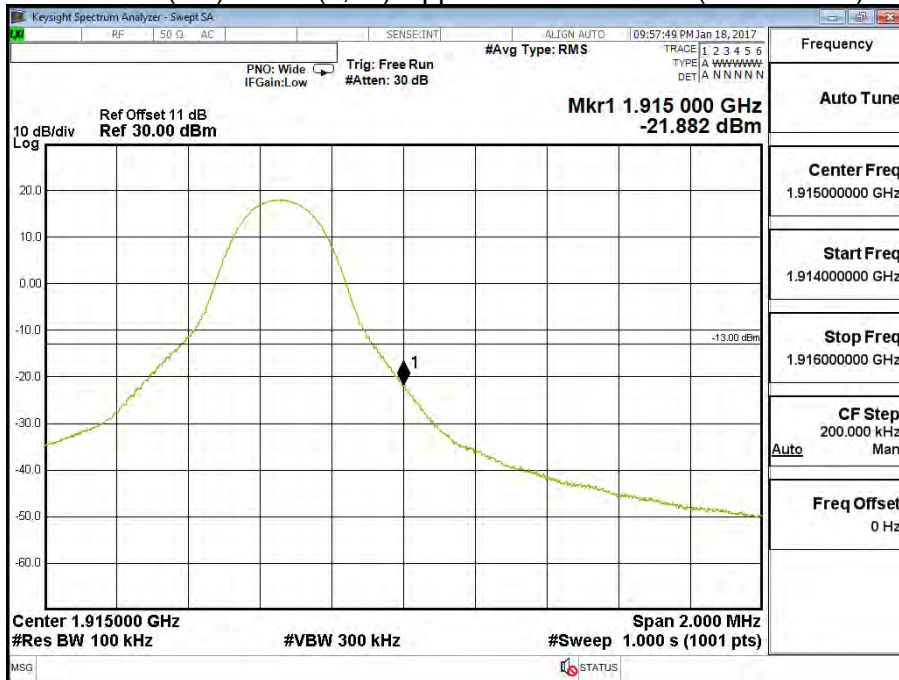

Band 25 (5M) QPSK(25,0) Lower Channel 26065 (1852.5MHz)

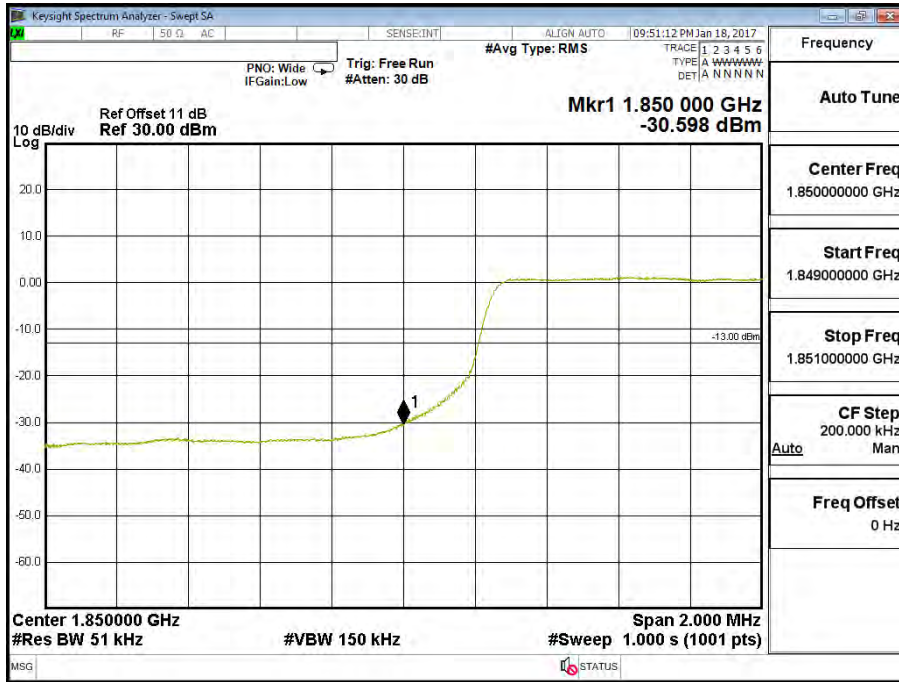

Band 25 (5M) QPSK(25,0) Upper Channel 26665 (1912.5MHz)

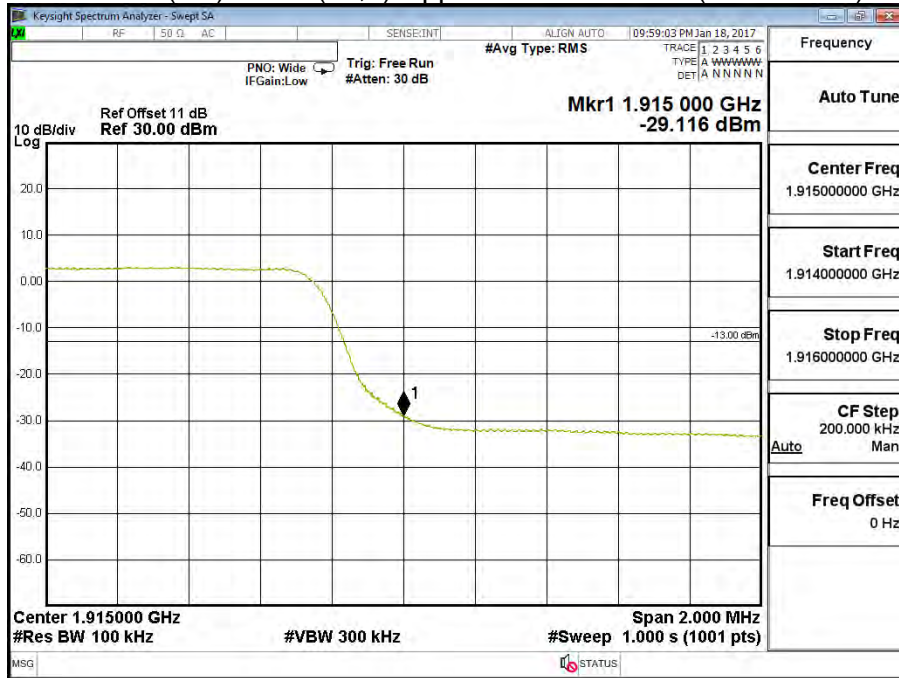

Band 25 (5M) 16QAM(1,0) Lower Channel 26065 (1852.5MHz)

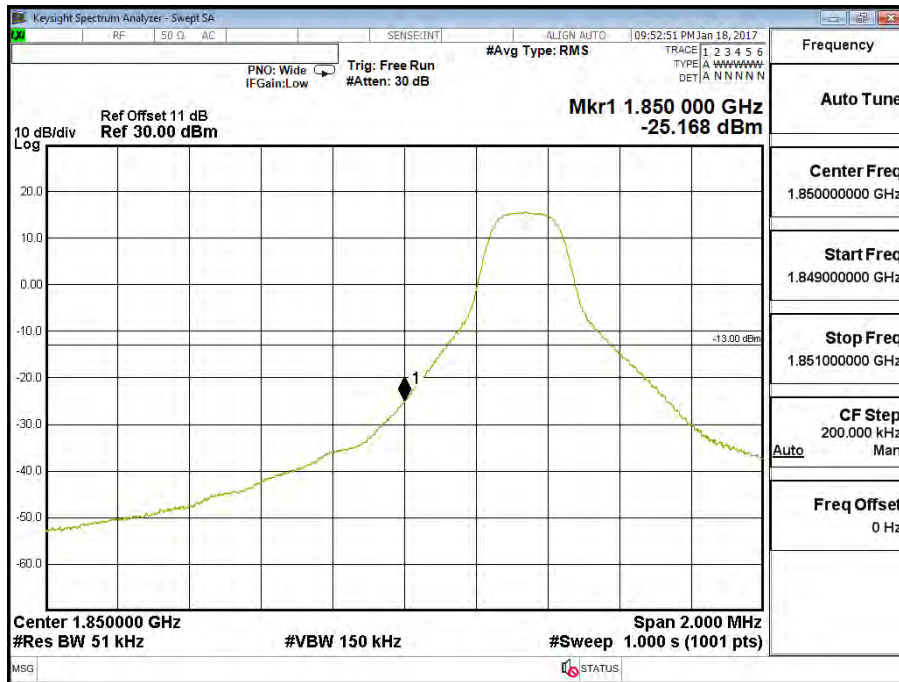

Band 25 (5M) 16QAM(1,24) Upper Channel 26665 (1912.5MHz)

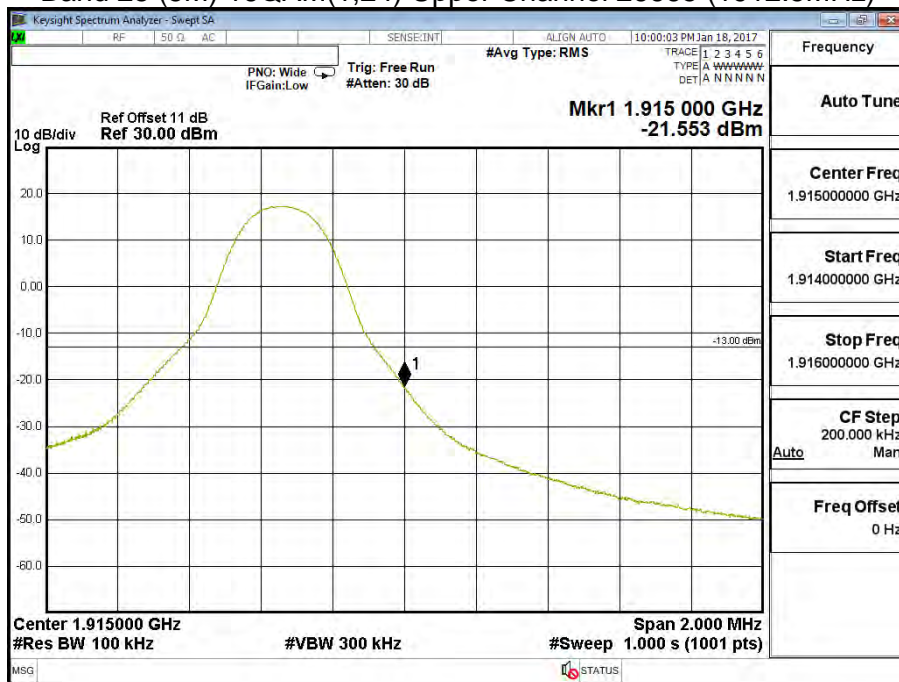

Band 25 (5M) 16QAM(25,0) Lower Channel 26065 (1852.5MHz)

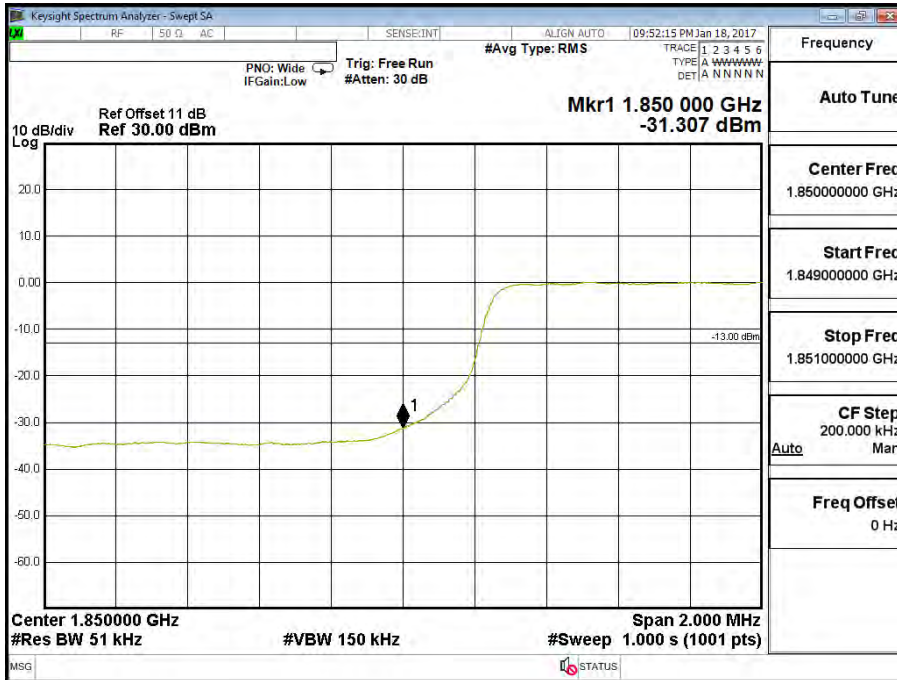

Band 25 (5M) 16QAM(25,0) Upper Channel 26665 (1912.5MHz)

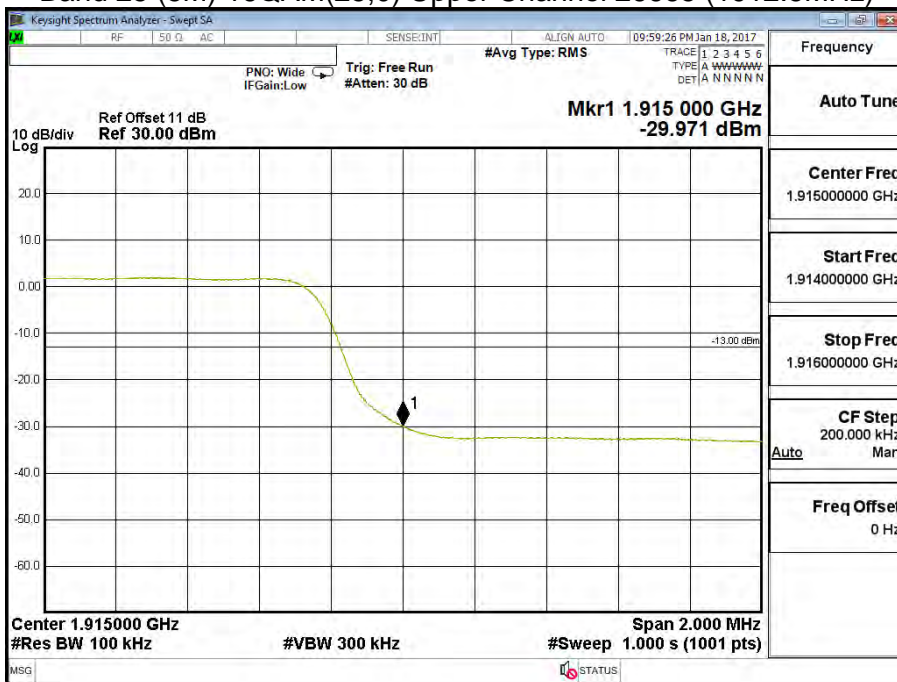

Product	Advanced Industrial 4G/LTE Router, WWAN Failover Manager		
Test Mode	Spurious Emission At Antenna Terminals (+/-1MHz)		
Date of Test	2017/01/18	Test Site	CTR
Test Condition	Block Edge Test (Band 25 (10M))		

Band 25 (10M) QPSK(1,0) Lower Channel 26090 (1855MHz)



Band 25 (10M) QPSK(1,49) Upper Channel 26640 (1910MHz)

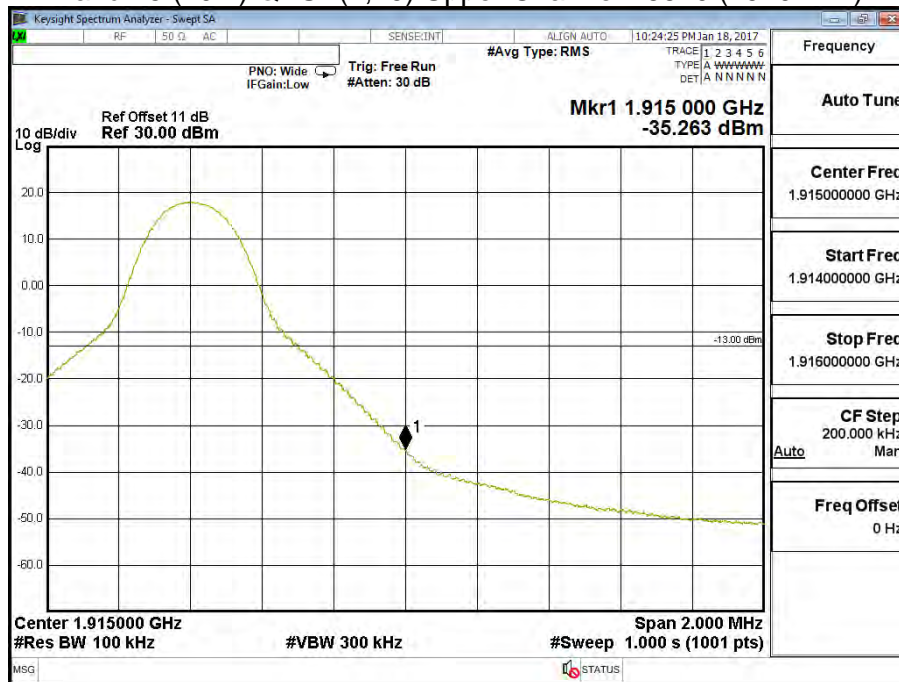

Band 25 (10M) QPSK(50,0) Lower Channel 26090 (1855MHz)

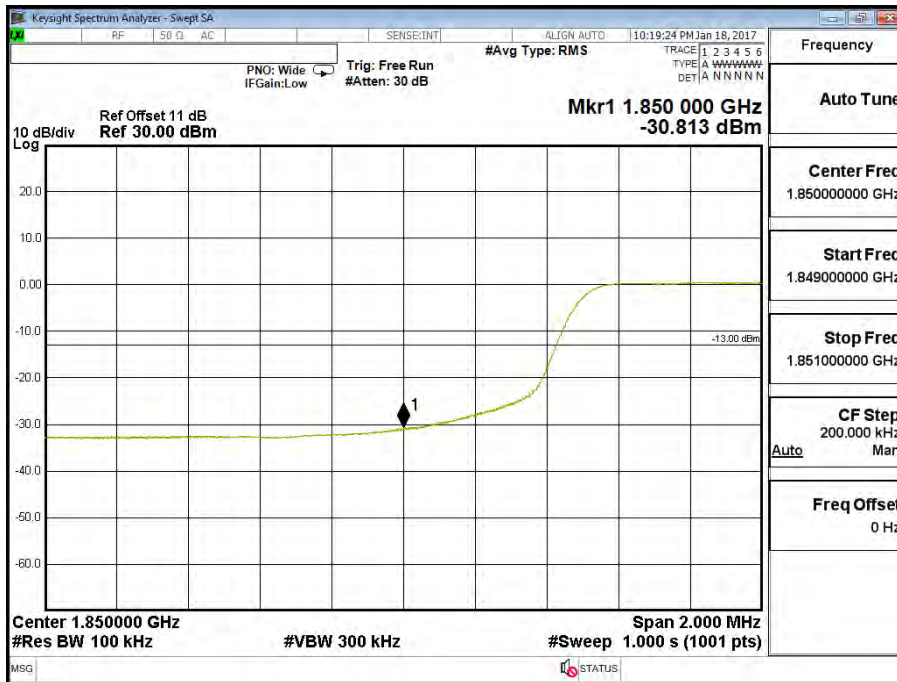

Band 25 (10M) QPSK(50,0) Upper Channel 26640 (1910MHz)

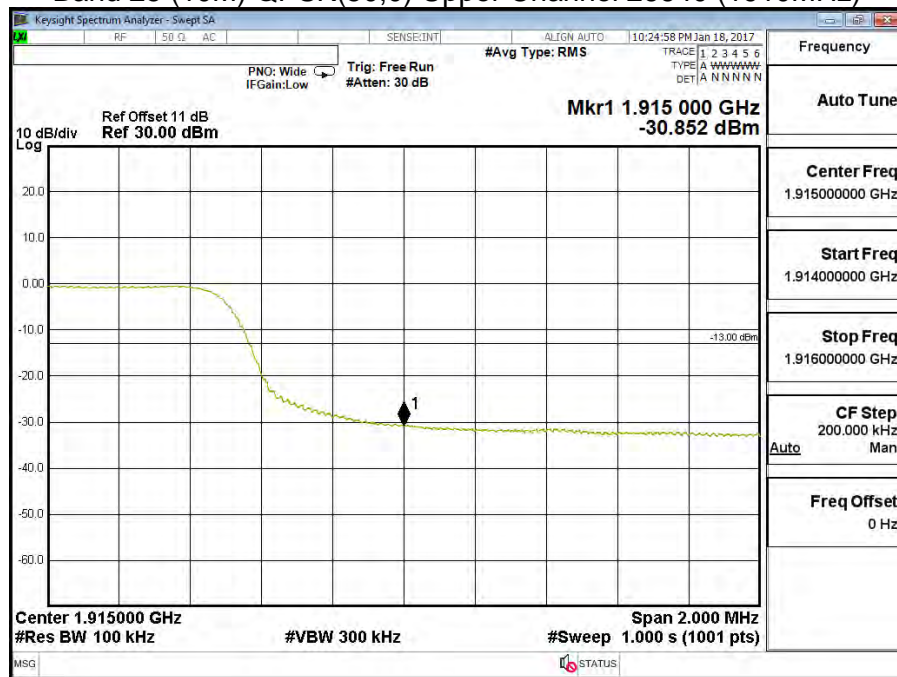

Band 25 (10M) 16QAM(1,0) Lower Channel 26090 (1855MHz)

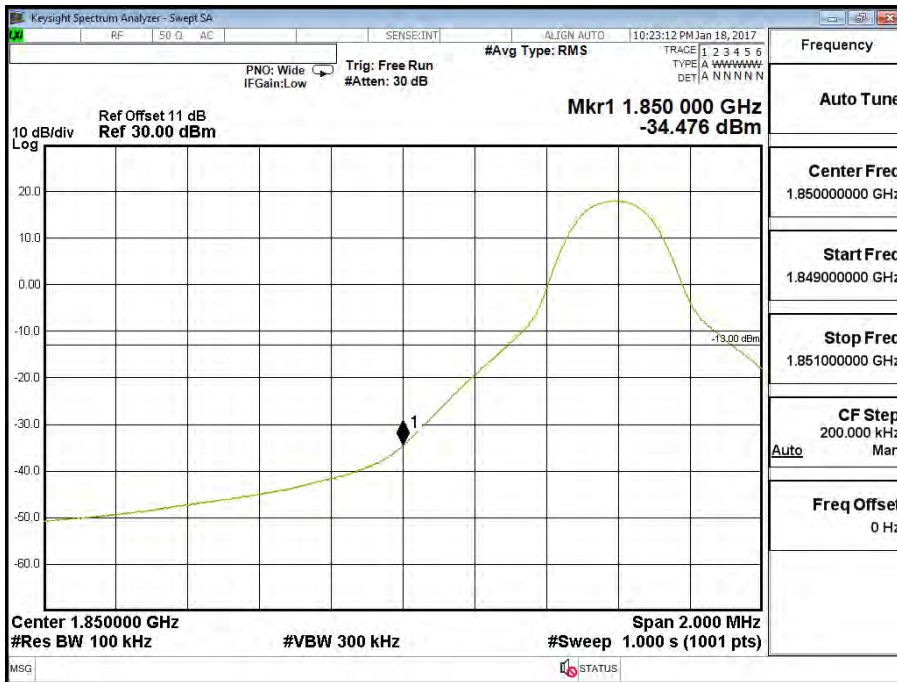

Band 25 (10M) 16QAM(1,49) Upper Channel 26640 (1910MHz)

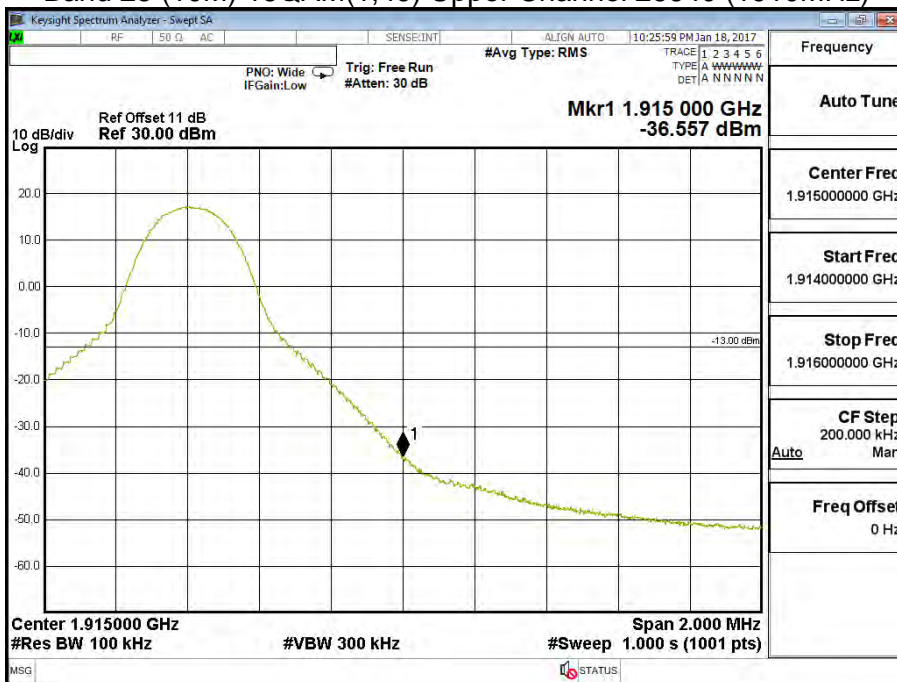

Band 25 (10M) 16QAM(50,0) Lower Channel 26090 (1855MHz)

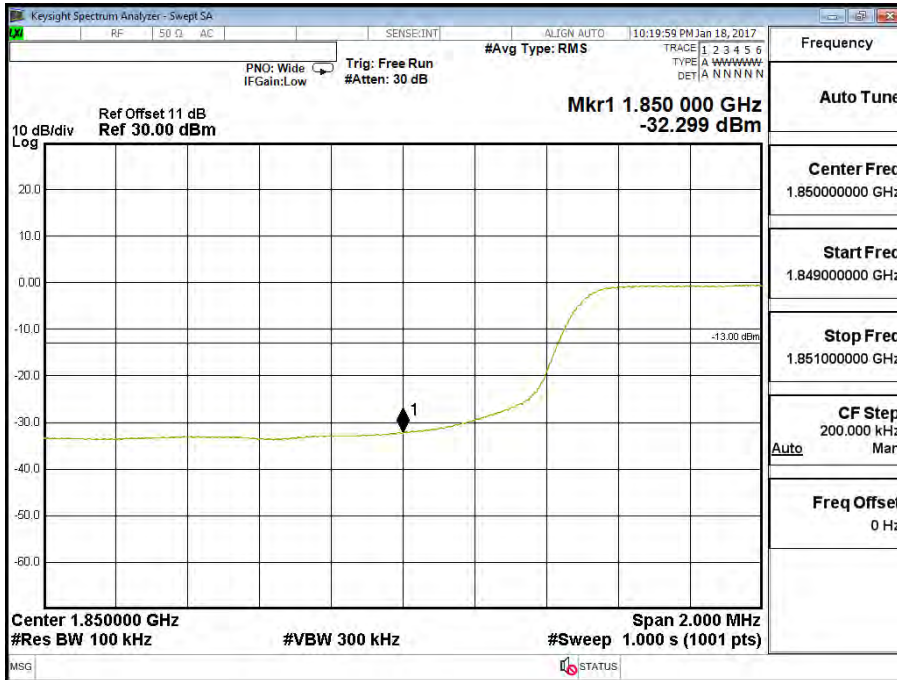

Band 25 (10M) 16QAM(50,0) Upper Channel 26640 (1910MHz)

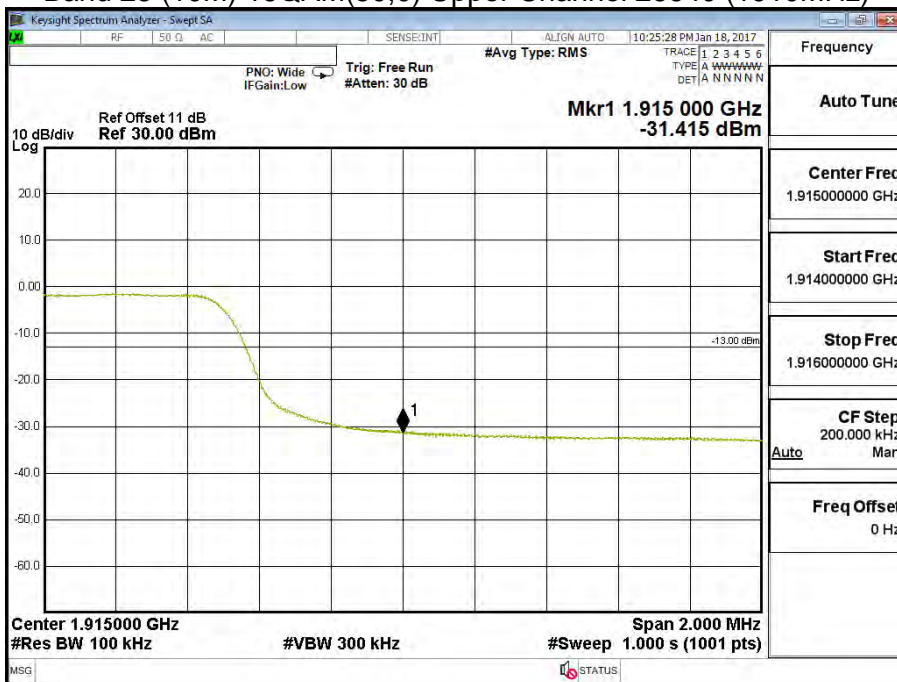

Product	Advanced Industrial 4G/LTE Router, WWAN Failover Manager		
Test Mode	Spurious Emission At Antenna Terminals (+/-1MHz)		
Date of Test	2017/01/18	Test Site	CTR
Test Condition	Block Edge Test (Band 25 (15M))		

Band 25 (15M)QPSK(1,0) Lower Channel 26155 (1857.5MHz)

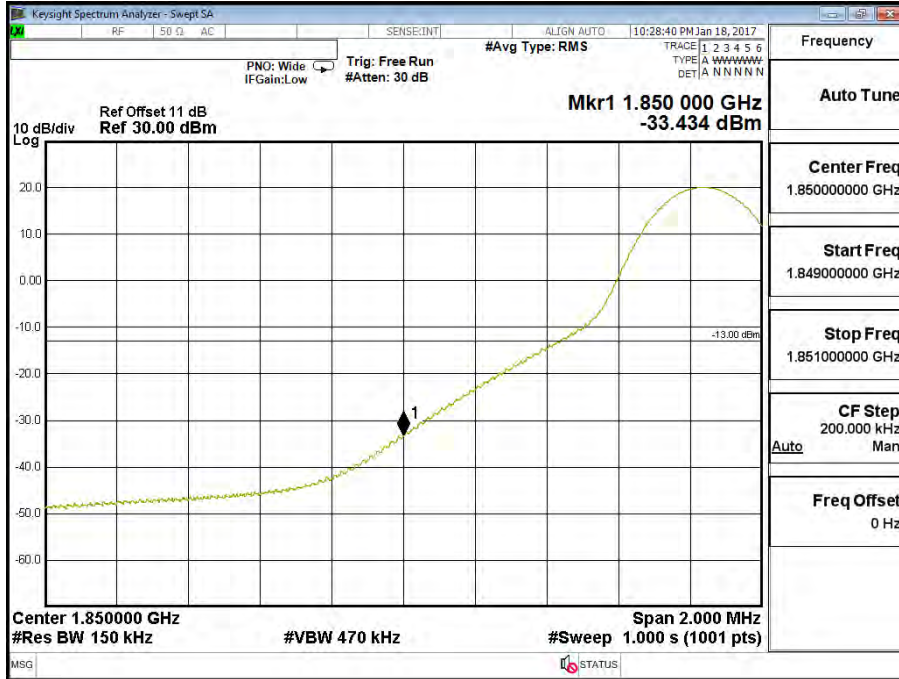

Band 25 (15M) QPSK(1,74) Upper Channel 26615 (1907.5MHz)

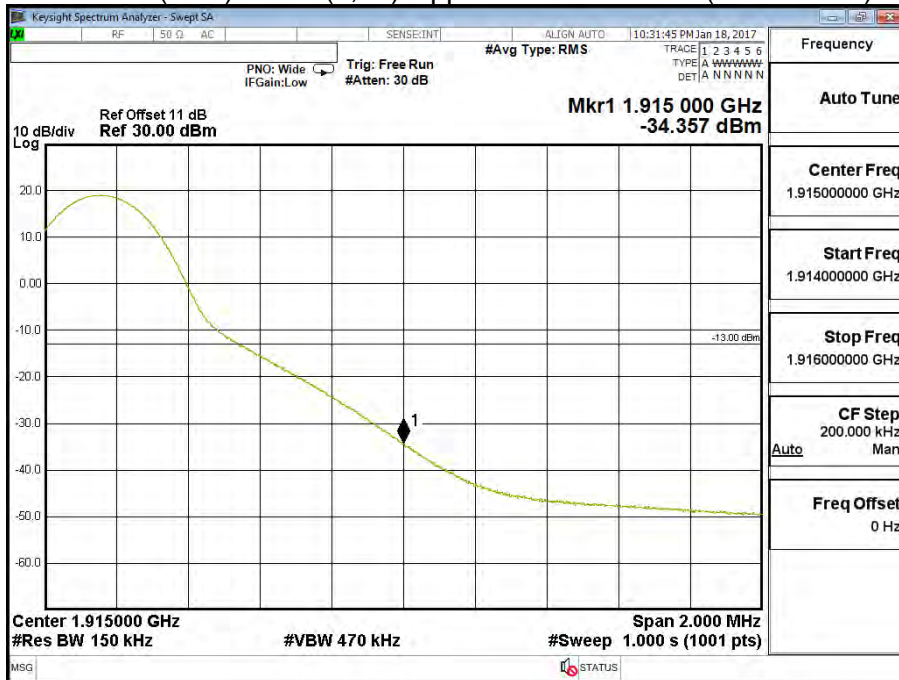

Band 25 (15M) QPSK(75,0) Lower Channel 26155 (1857.5MHz)

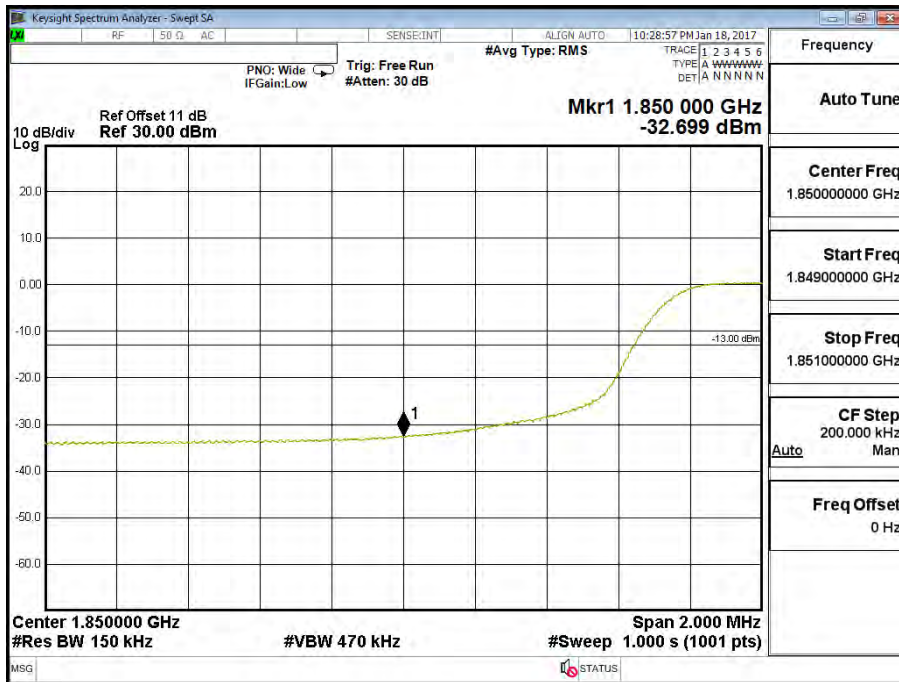

Band 25 (15M) QPSK(75,0) Upper Channel 26615 (1907.5MHz)

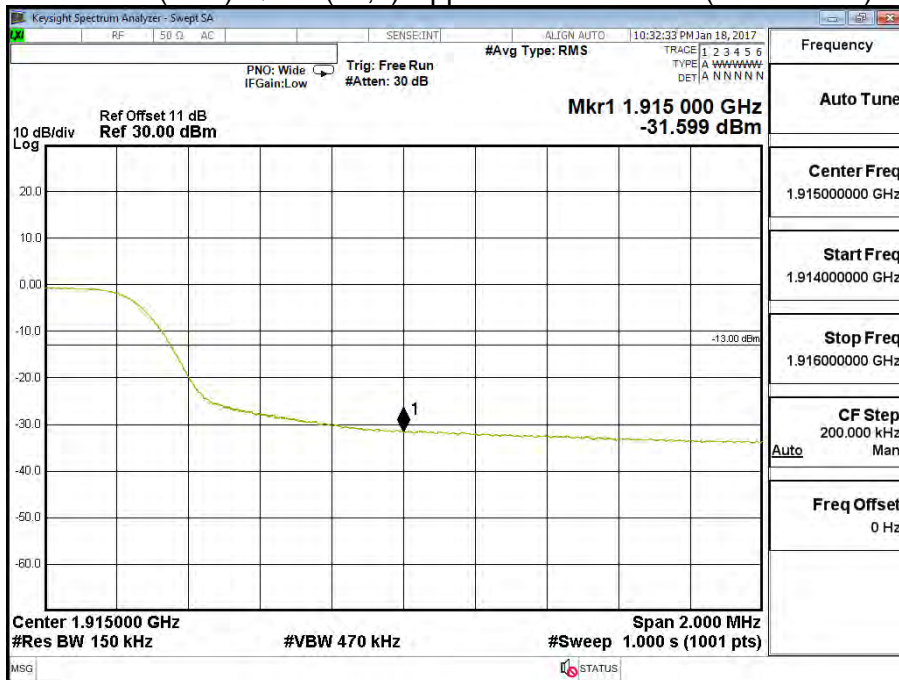

Band 25 (15M) 16QAM(1,0) Lower Channel 26155 (1857.5MHz)



Band 25 (15M) 16QAM(1,74) Upper Channel 26615 (1907.5MHz)

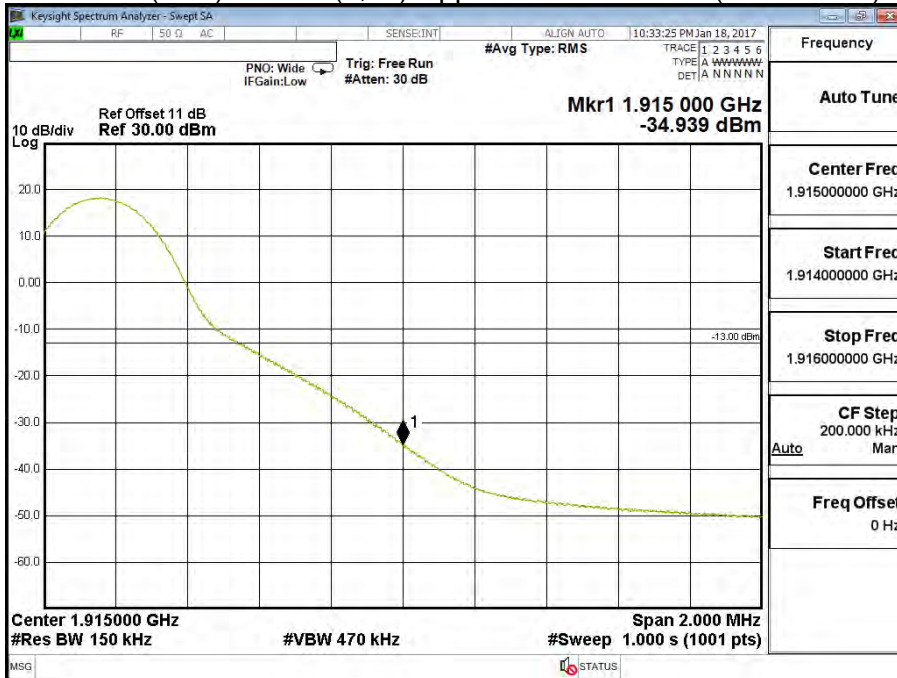

Band 25 (15M) 16QAM(75,0) Lower Channel 26155 (1857.5MHz)

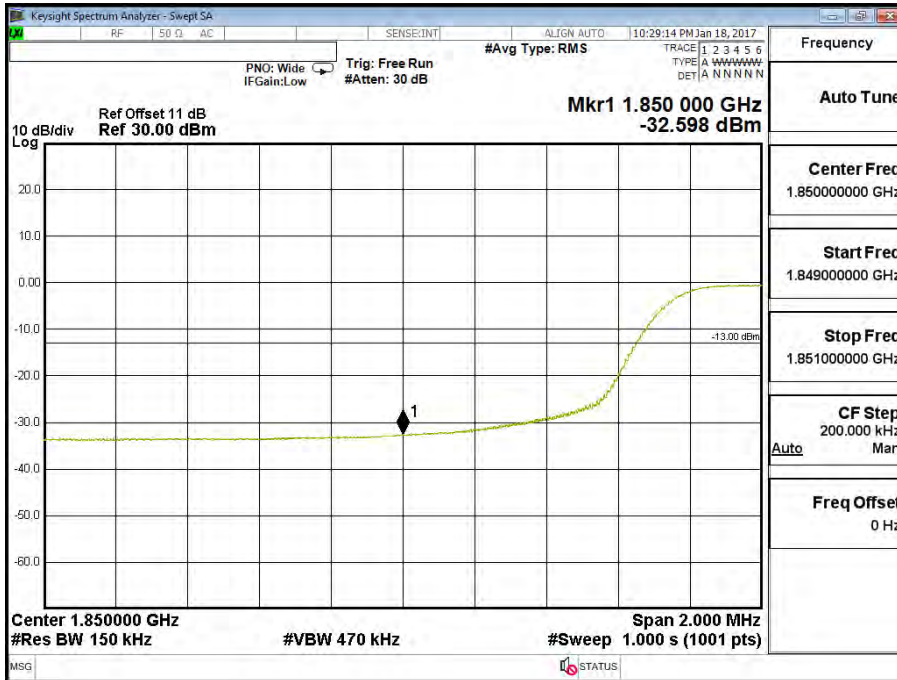

Band 25 (15M) 16QAM(75,0) Upper Channel 26615 (1907.5MHz)

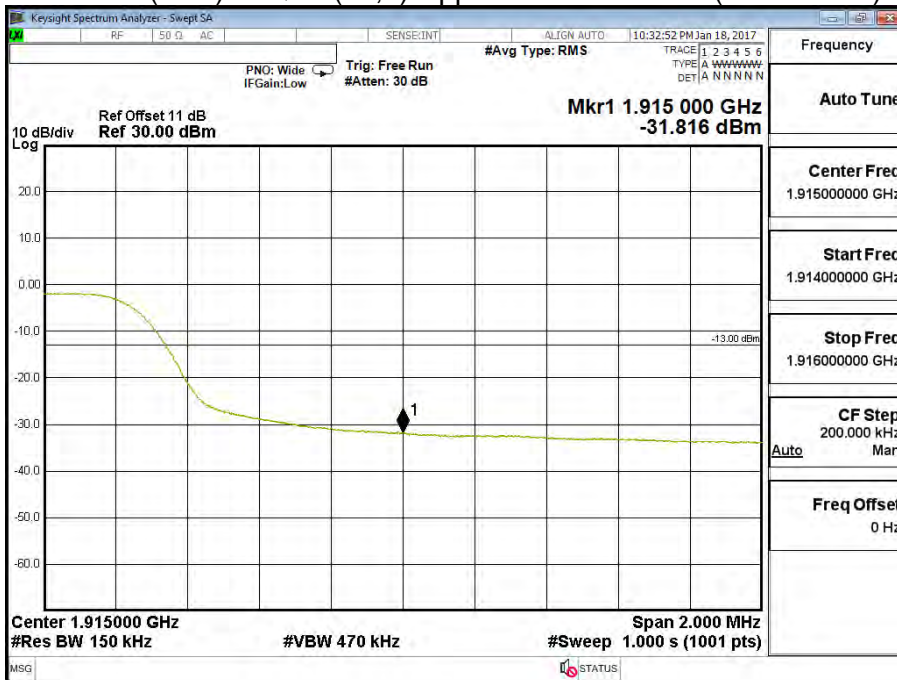

Product	Advanced Industrial 4G/LTE Router, WWAN Failover Manager		
Test Mode	Spurious Emission At Antenna Terminals (+/-1MHz)		
Date of Test	2017/01/18	Test Site	CTR
Test Condition	Block Edge Test (Band 25 (20M))		

Band 25 (20M) QPSK(1,0) Lower Channel 26140 (1860MHz)

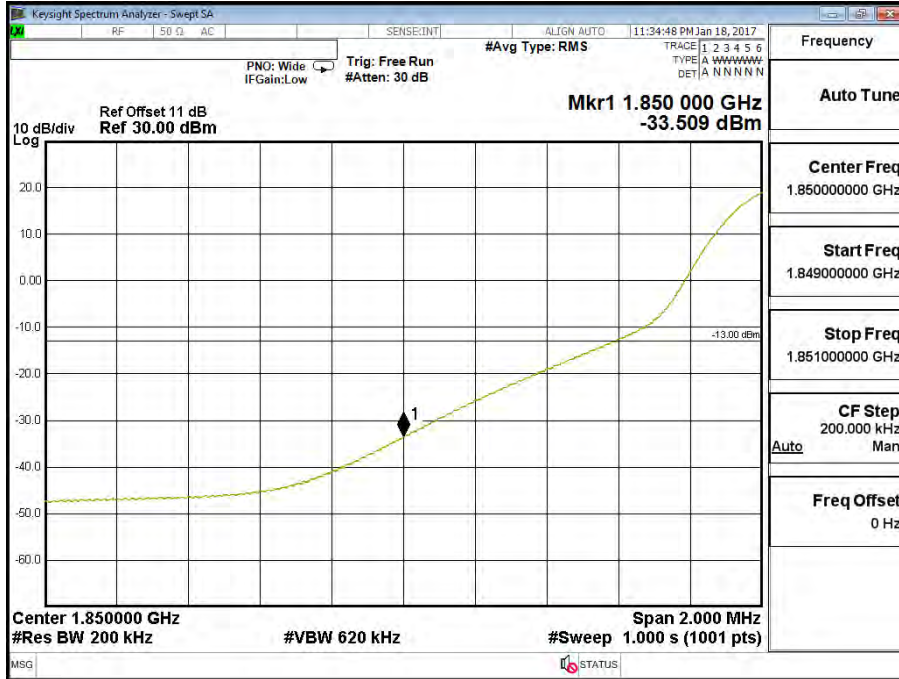

Band 25 (20M) QPSK(1,99) Upper Channel 26590 (1905MHz)



Band 25 (20M) QPSK(100,0) Lower Channel 26140 (1860MHz)

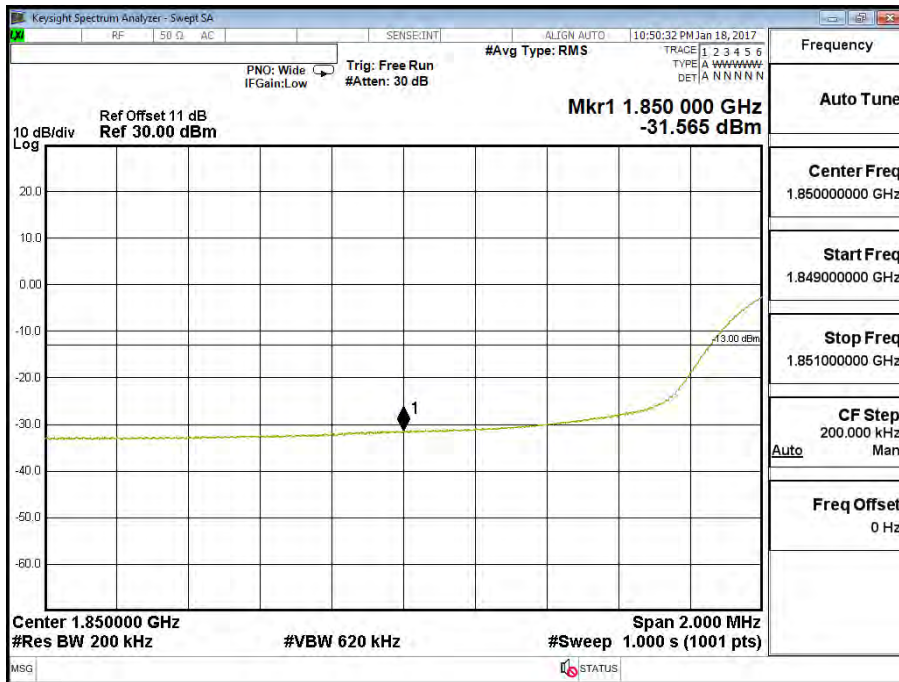

Band 25 (20M) QPSK(100,0) Upper Channel 26590 (1905MHz)

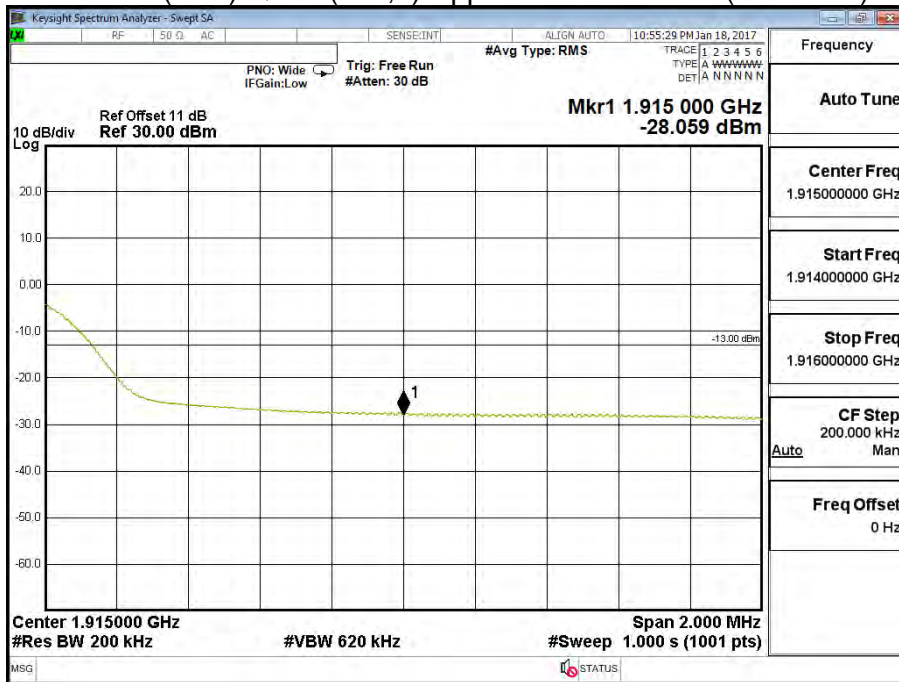

Band 25 (20M) 16QAM(1,0) Lower Channel 26140 (1860MHz)

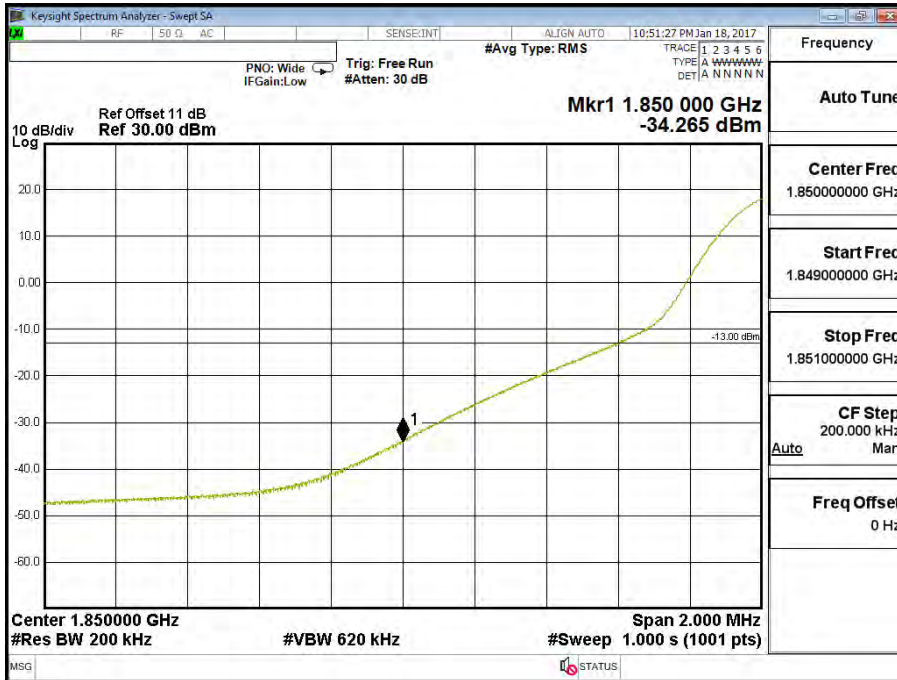

Band 25 (20M) 16QAM(1,99) Upper Channel 26590 (1905MHz)

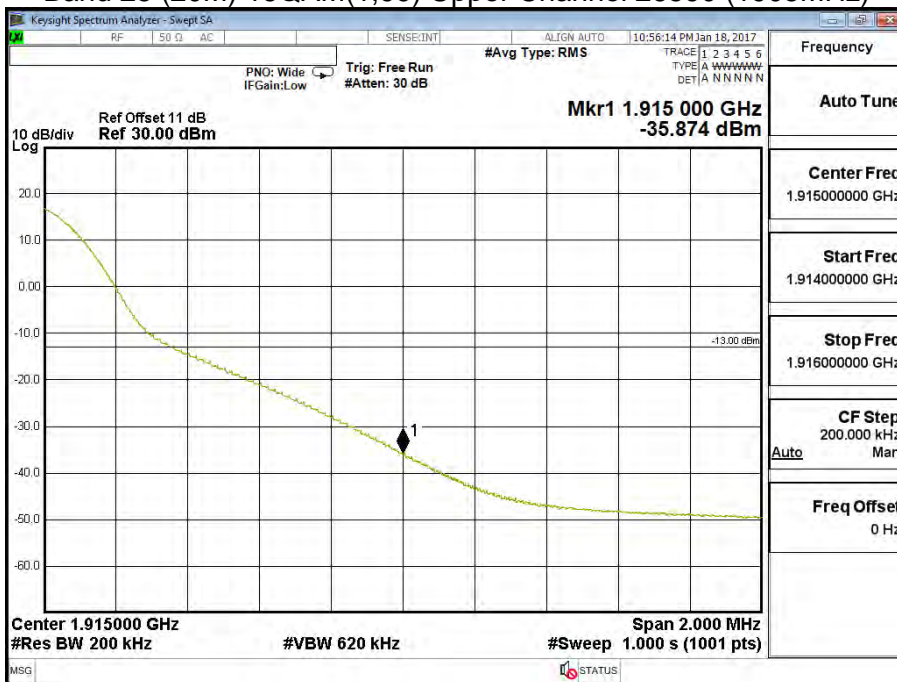

Band 25 (20M) 16QAM(100,0) Lower Channel 26140 (1860MHz)

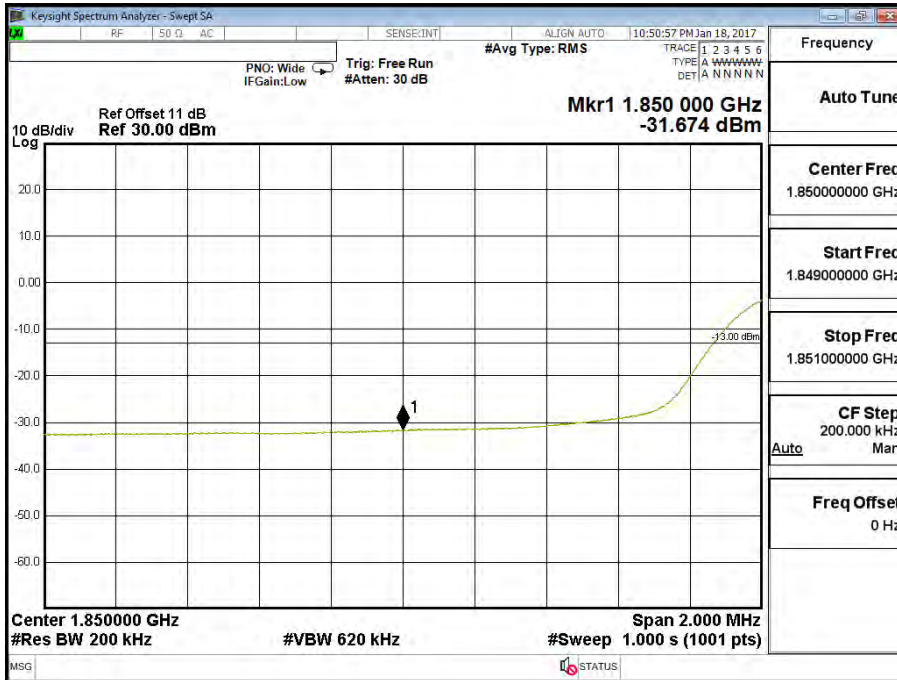

Band 25 (20M) 16QAM(100,0) Upper Channel 26590 (1905MHz)

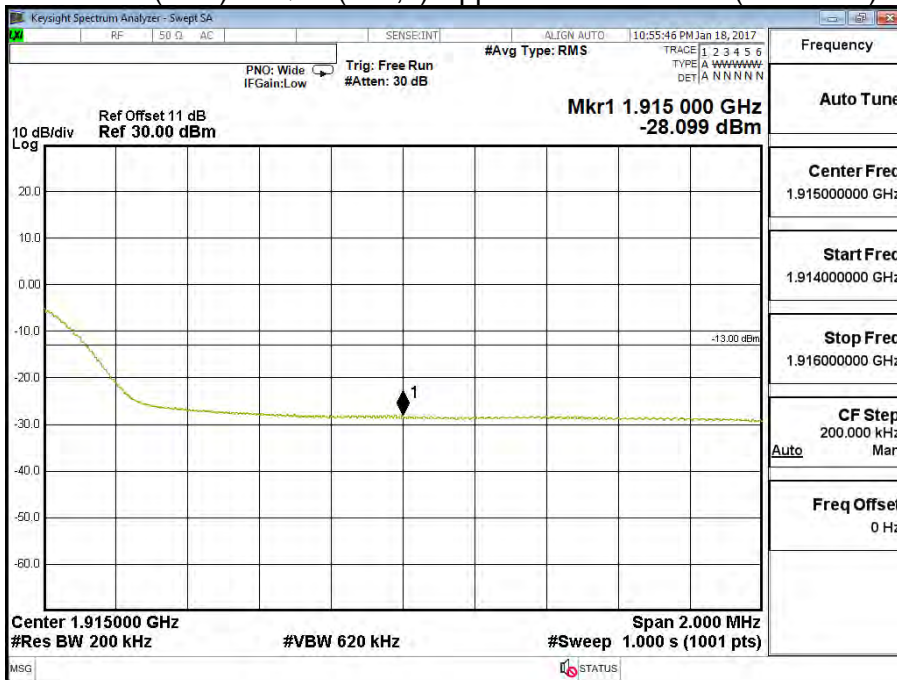

Product	Advanced Industrial 4G/LTE Router, WWAN Failover Manager		
Test Mode	Spurious Emission At Antenna Terminals (+/-1MHz)		
Date of Test	2017/02/06	Test Site	CTR
Test Condition	Block Edge Test (Band 26 (1.4M))		

Band 26 (1.4M) QPSK(1,0) Lower Channel 26797 (824.7MHz)

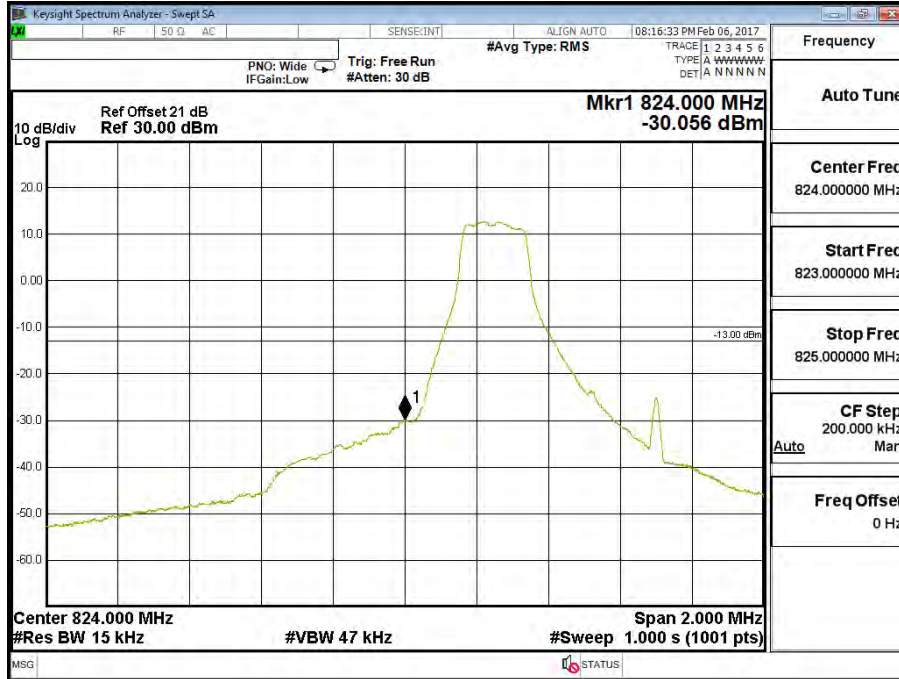

Band 26 (1.4M) QPSK(1,5) Upper Channel 27033 (848.3MHz)

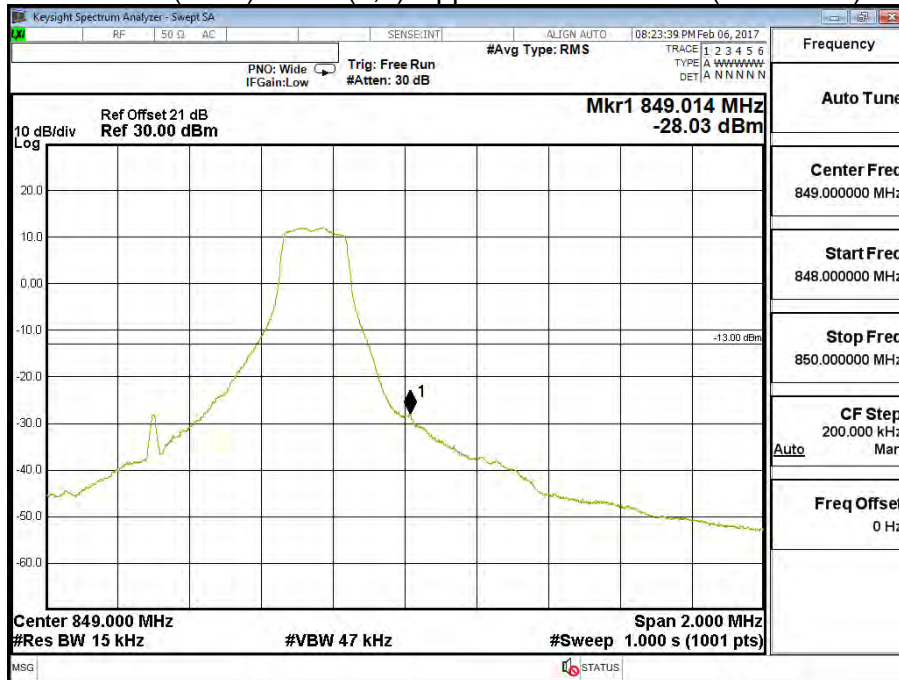

Band 26 (1.4M) QPSK(6,0) Lower Channel 26797 (824.7MHz)

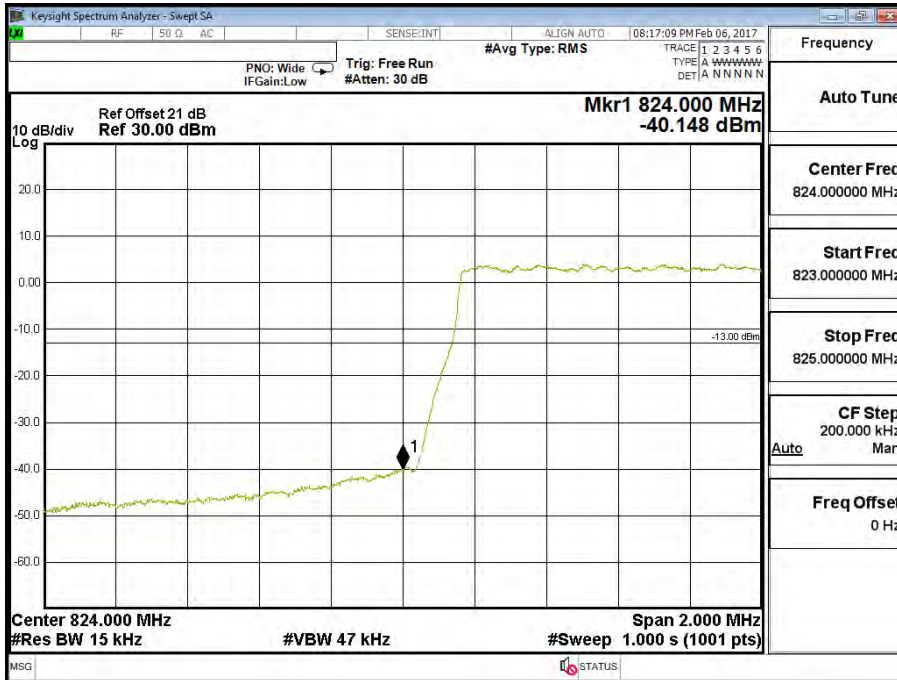

Band 26 (1.4M) QPSK(6,0) Upper Channel 27033 (848.3MHz)

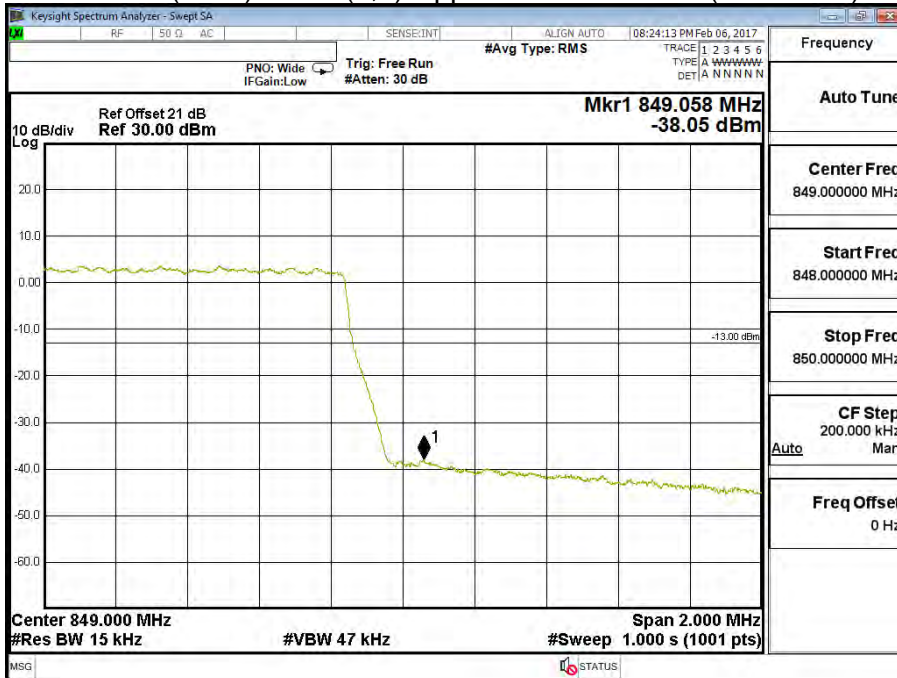

Band 26 (1.4M) 16QAM(1,0) Lower Channel 26797 (824.7MHz)

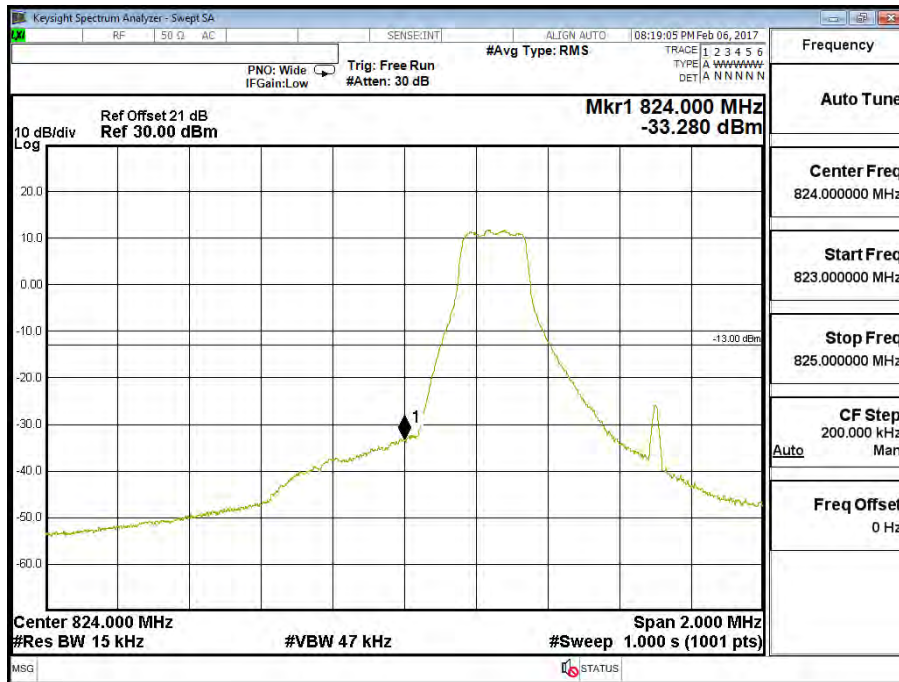

Band 26 (1.4M) 16QAM(1,5) Upper Channel 27033 (848.3MHz)

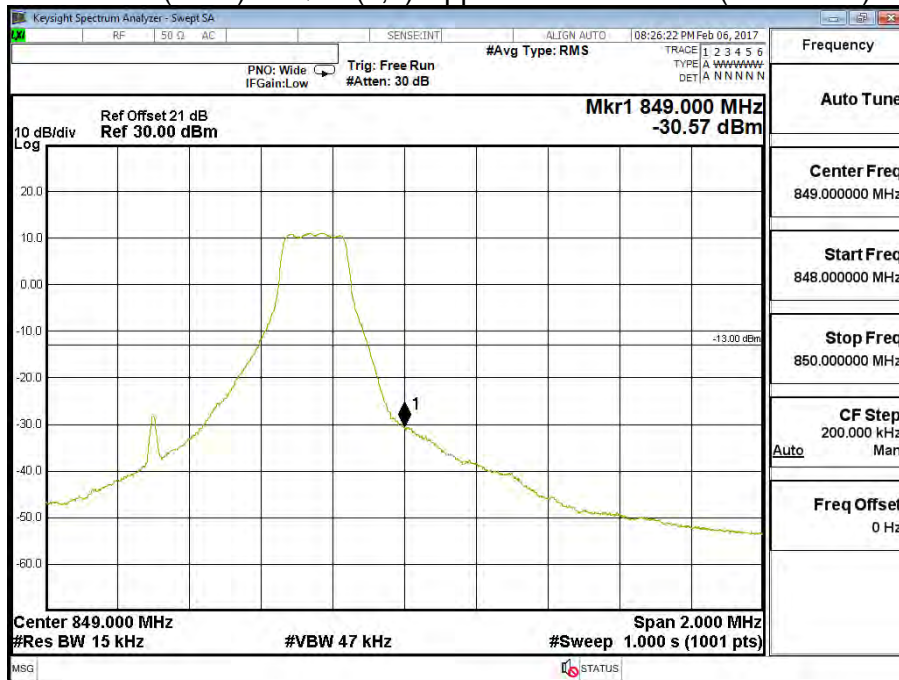

Band 26 (1.4M) 16QAM(6,0) Lower Channel 26797 (824.7MHz)

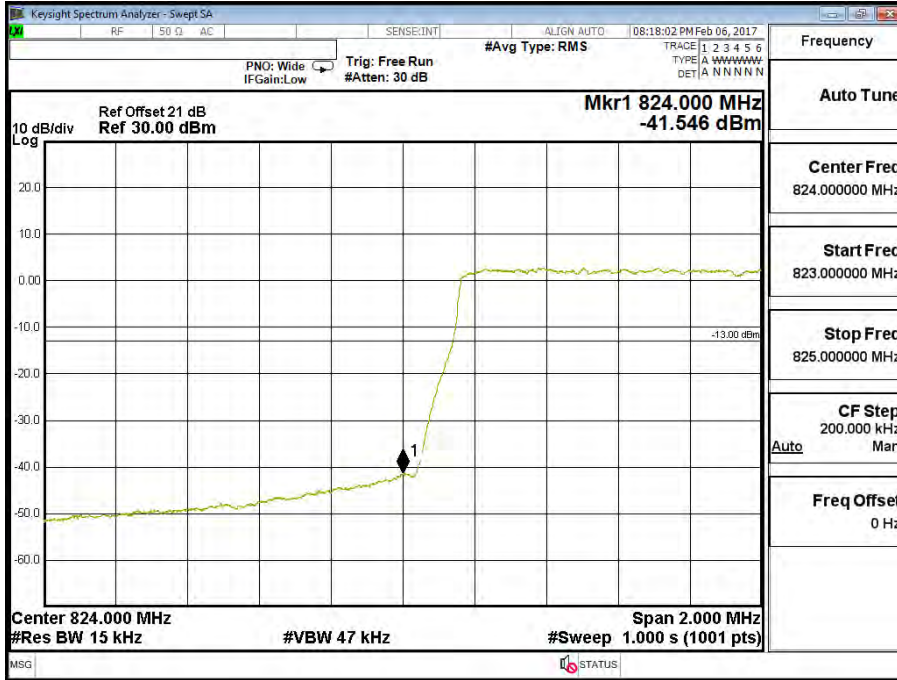

Band 26 (1.4M) 16QAM(6,0) Upper Channel 27033 (848.3MHz)

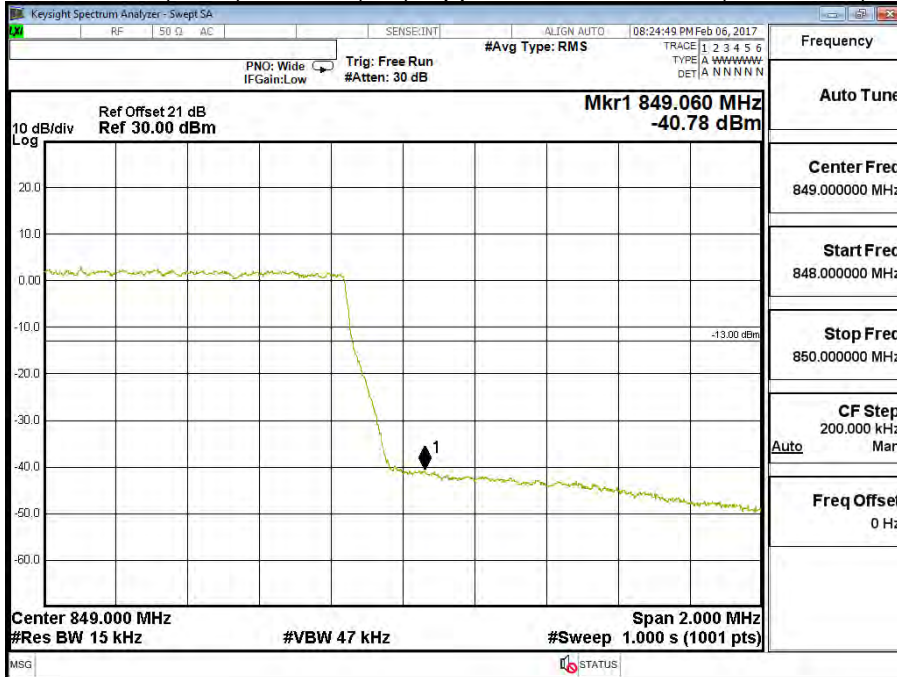

Product	Advanced Industrial 4G/LTE Router, WWAN Failover Manager		
Test Mode	Spurious Emission At Antenna Terminals (+/-1MHz)		
Date of Test	2017/02/06	Test Site	CTR
Test Condition	Block Edge Test (Band 26 (3M))		

Band 26 (3M) QPSK(1,0) Lower Channel 26805 (825.5MHz)

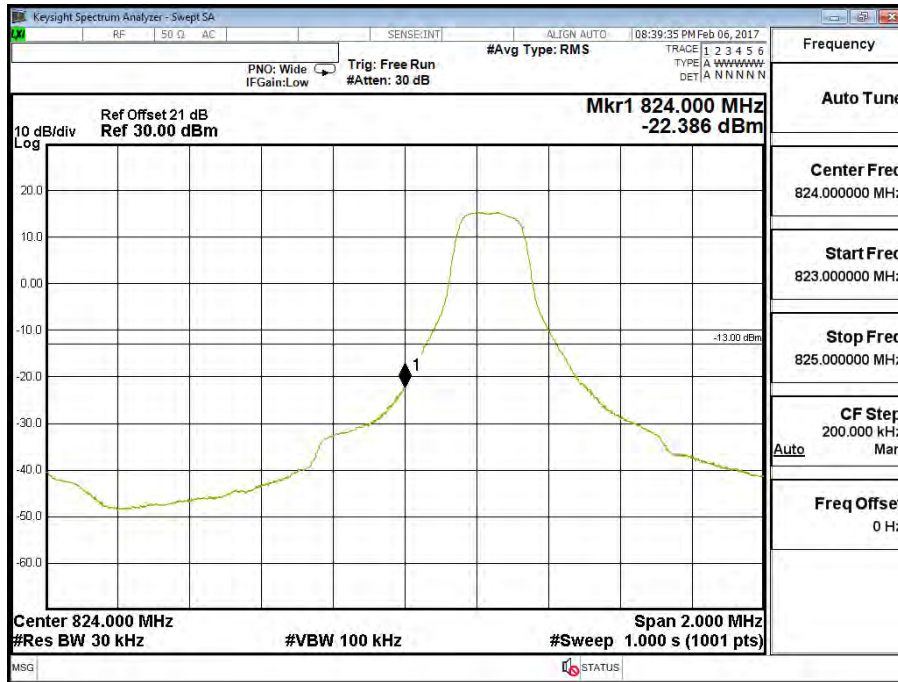

Band 26 (3M) QPSK(1,14) Upper Channel 27025 (847.5MHz)

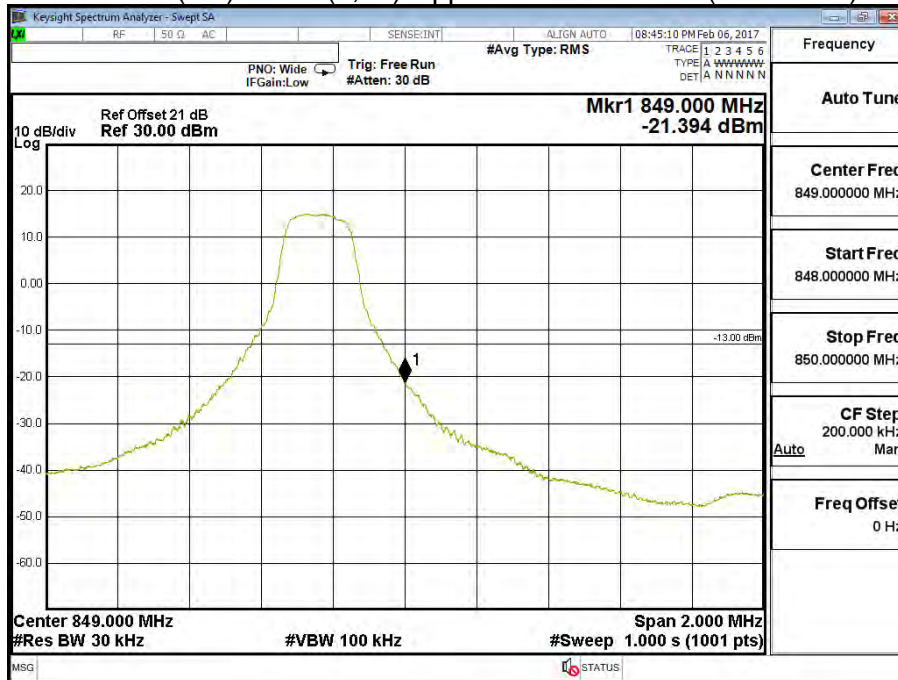

Band 26 (3M) QPSK(15,0) Lower Channel 26805 (825.5MHz)

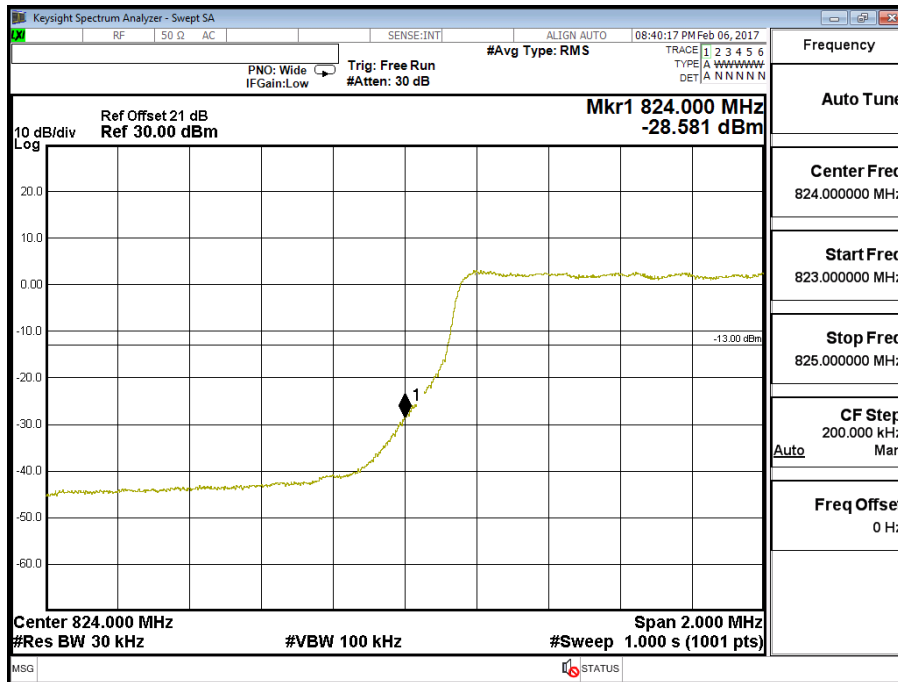

Band 26 (3M) QPSK(15,0) Upper Channel 27025 (847.5MHz)

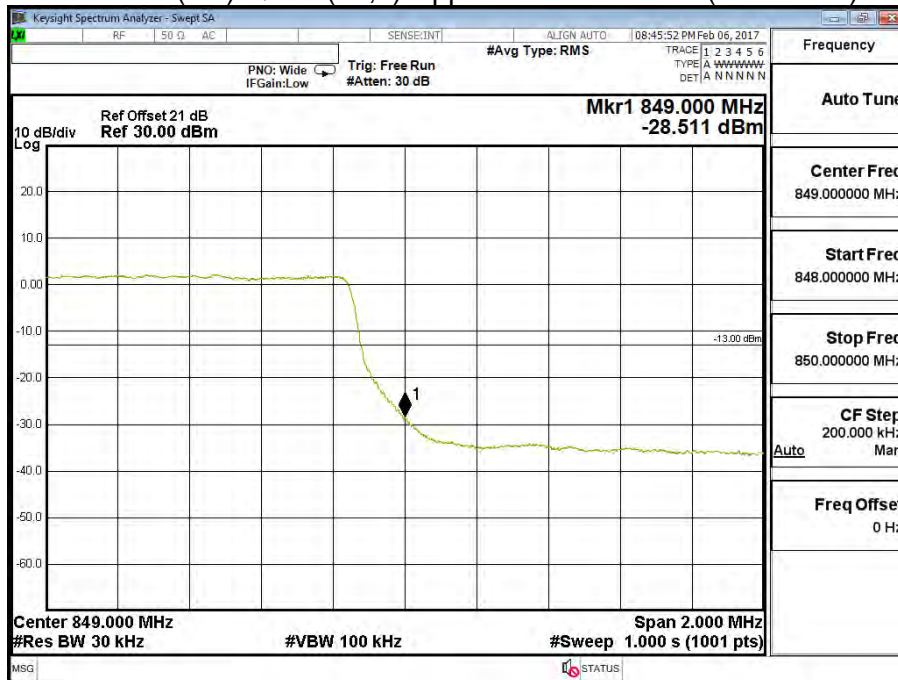

Band 26 (3M) 16QAM(1,0) Lower Channel 26805 (825.5MHz)

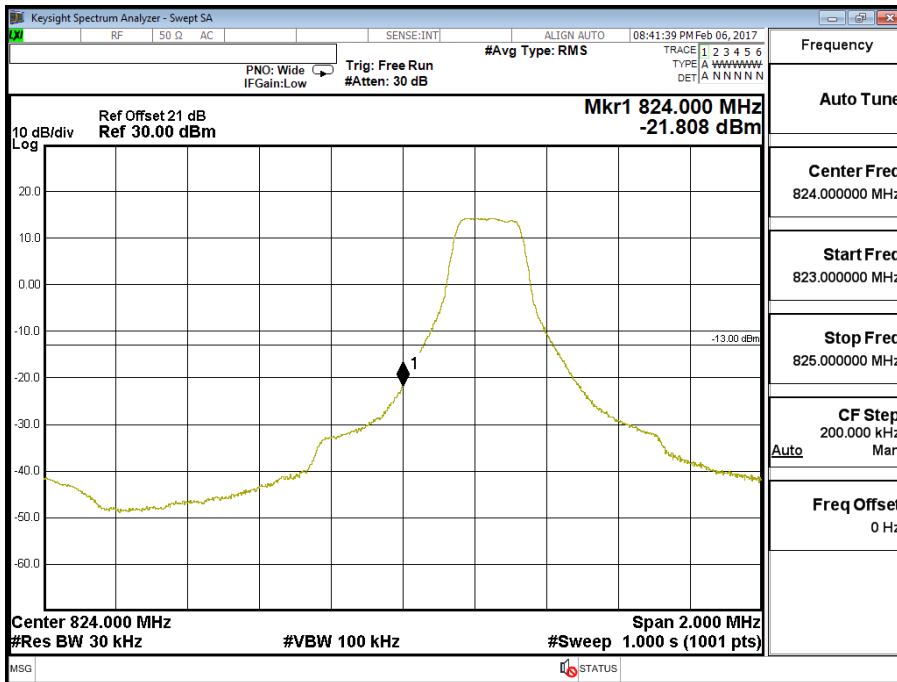

Band 26 (3M) 16QAM(1,14) Upper Channel 27025 (847.5MHz)

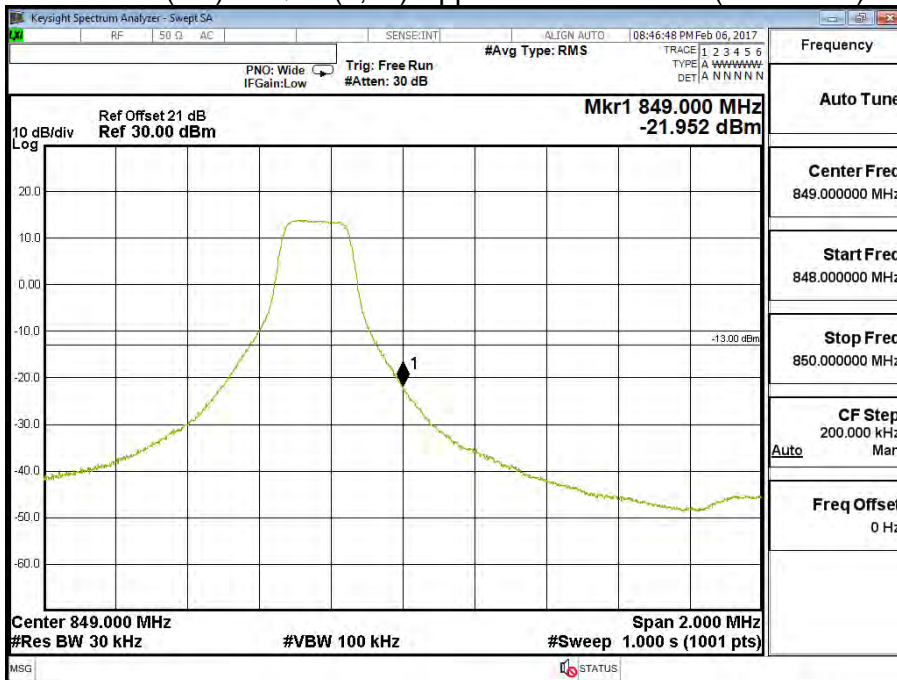

Band 26 (3M) 16QAM(15,0) Lower Channel 26805 (825.5MHz)

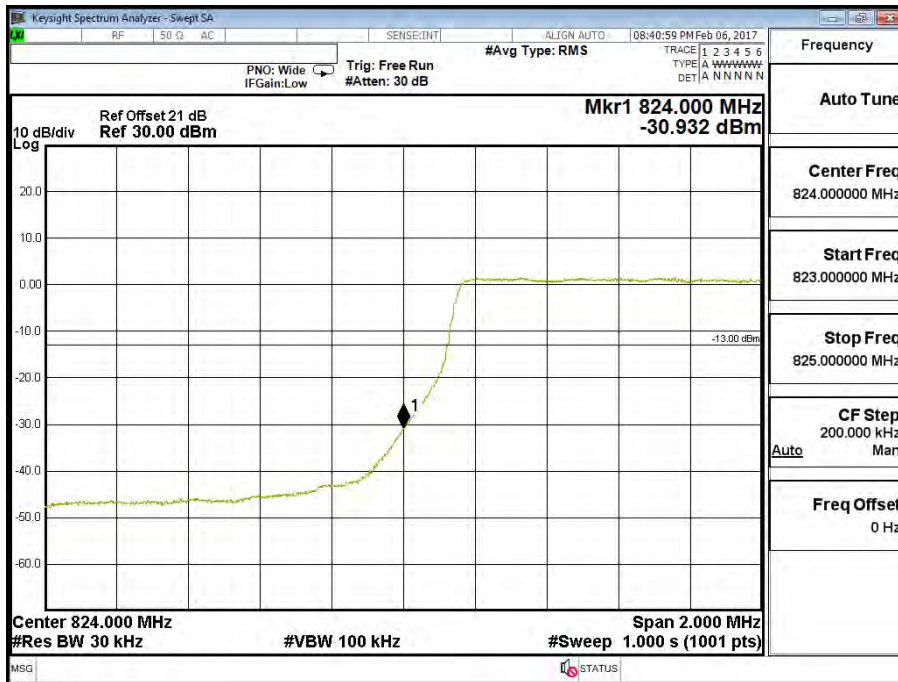

Band 26 (3M) 16QAM(15,0) Upper Channel 27025 (847.5MHz)

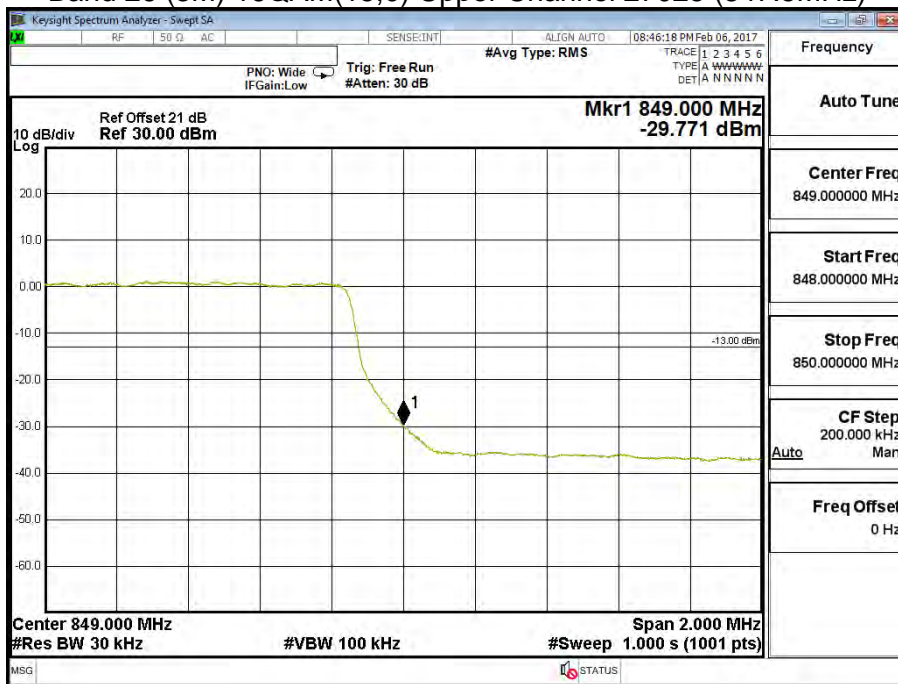

Product	Advanced Industrial 4G/LTE Router, WWAN Failover Manager		
Test Mode	Spurious Emission At Antenna Terminals (+/-1MHz)		
Date of Test	2017/02/06	Test Site	CTR
Test Condition	Block Edge Test (Band 26 (5M))		

Band 26 (5M) QPSK(1,0) Lower Channel 26815 (826.5MHz)

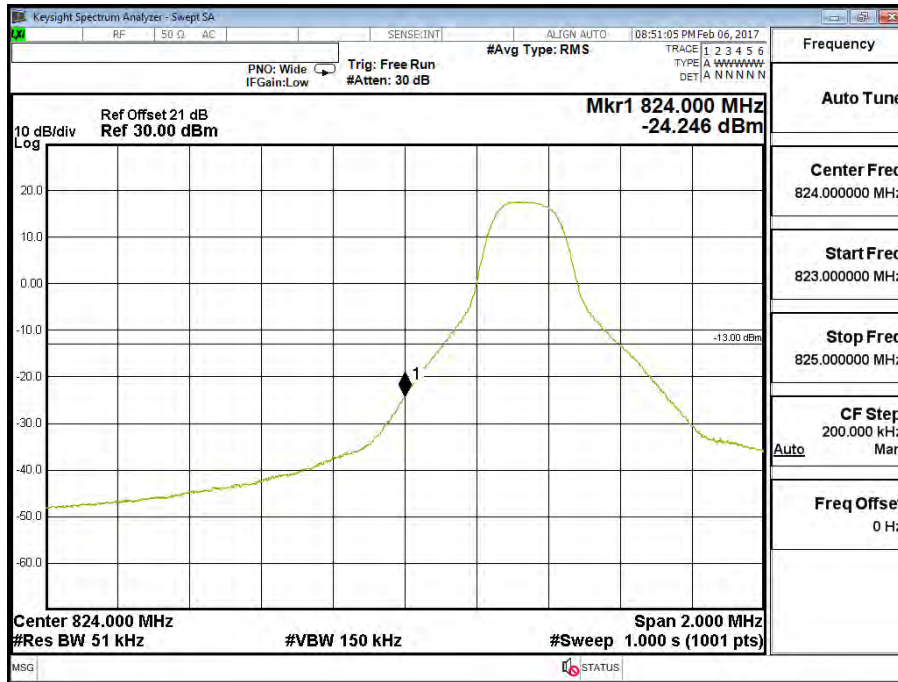

Band 26 (5M) QPSK(1,24) Upper Channel 27015 (846.5MHz)

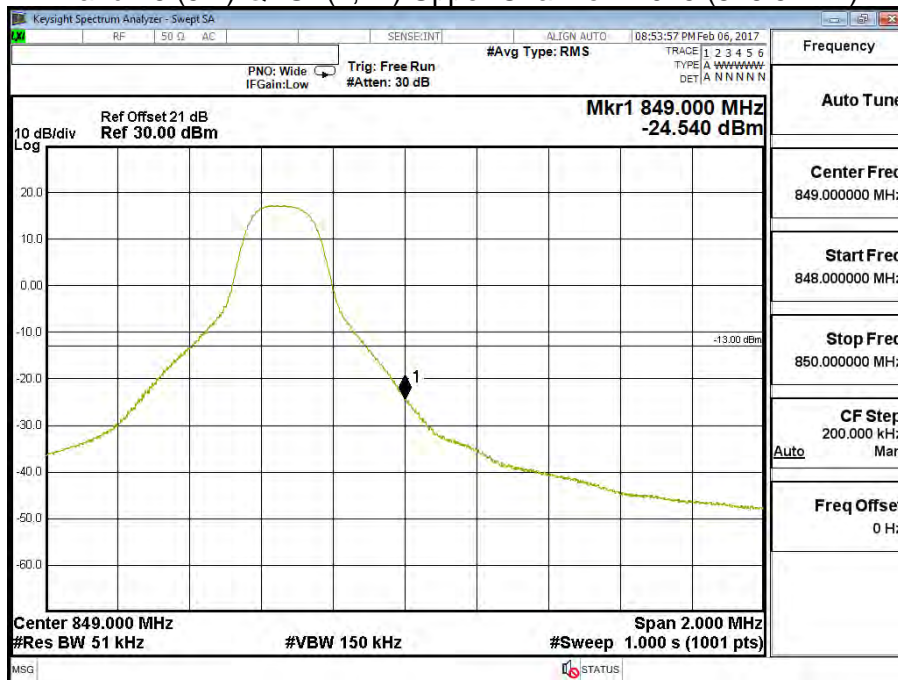

Band 26 (5M) QPSK(25,0) Lower Channel 26815 (826.5MHz)

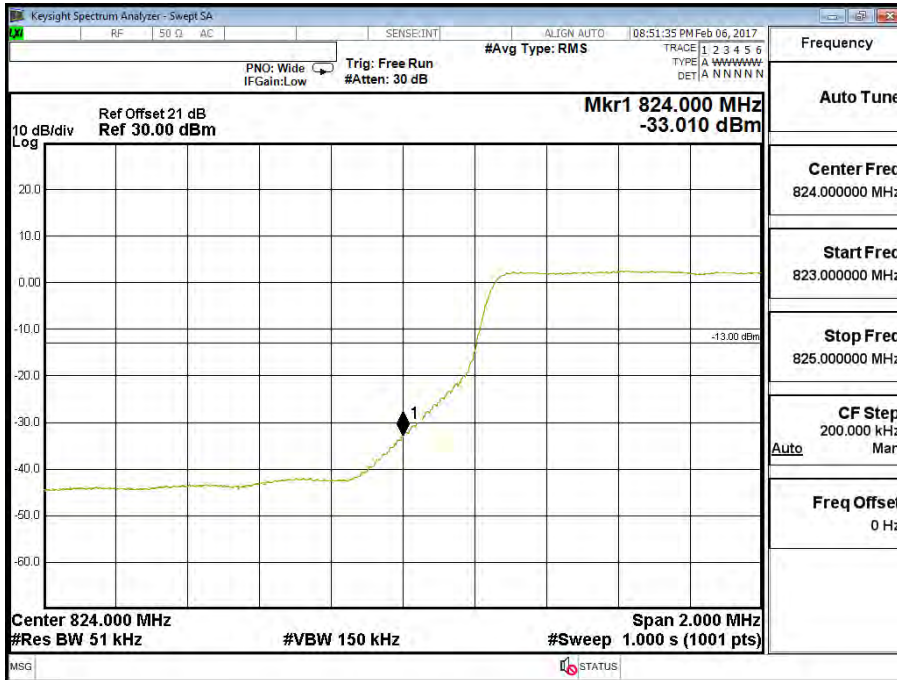

Band 26 (5M) QPSK(25,0) Upper Channel 27015 (846.5MHz)

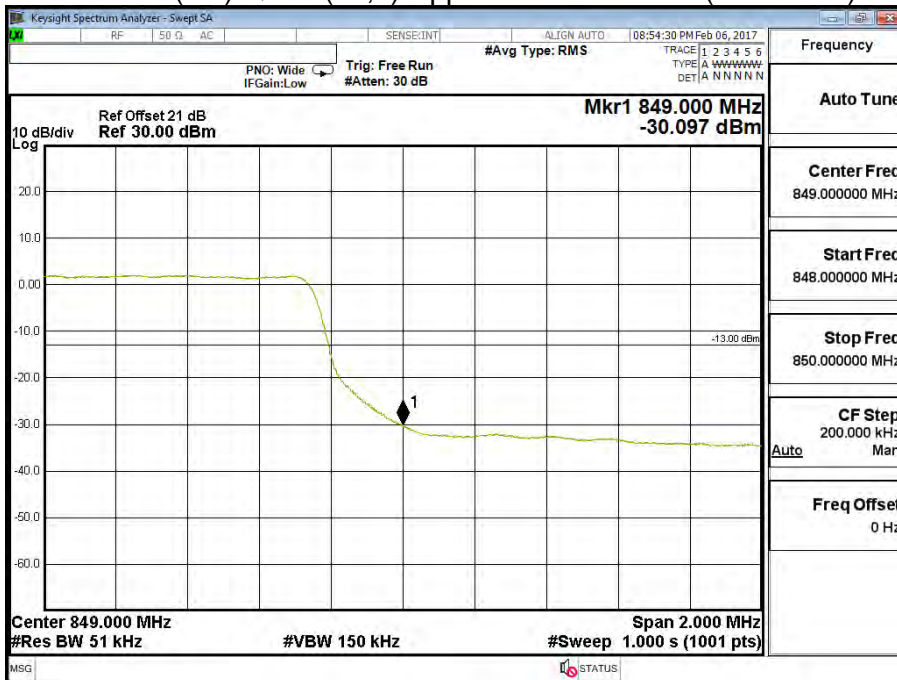

Band 26 (5M) 16QAM(1,0) Lower Channel 26815 (826.5MHz)

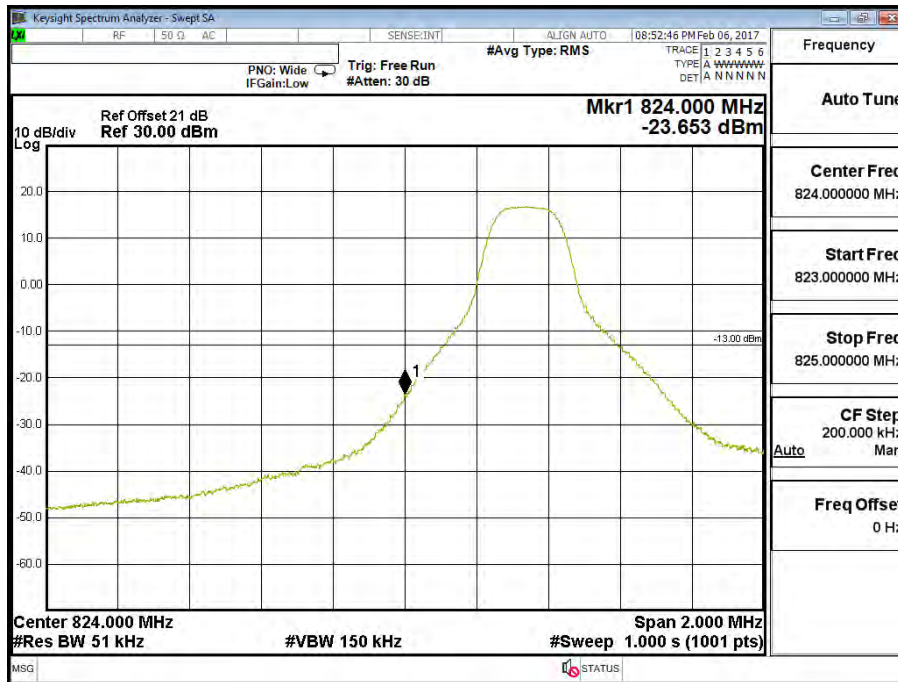

Band 26 (5M) 16QAM(1,24) Upper Channel 27015 (846.5MHz)

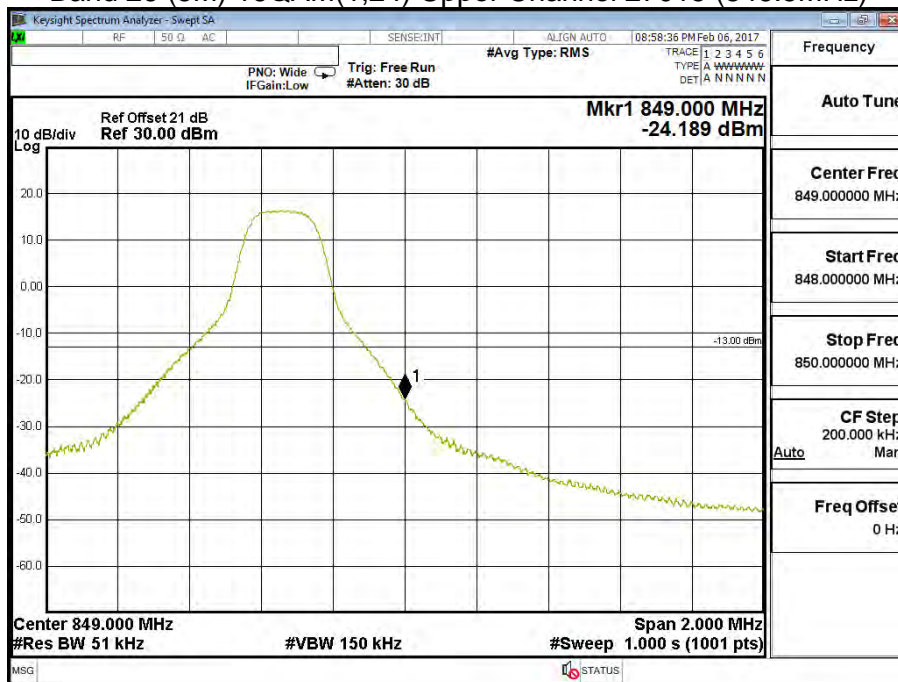

Band 26 (5M) 16QAM(25,0) Lower Channel 26815 (826.5MHz)

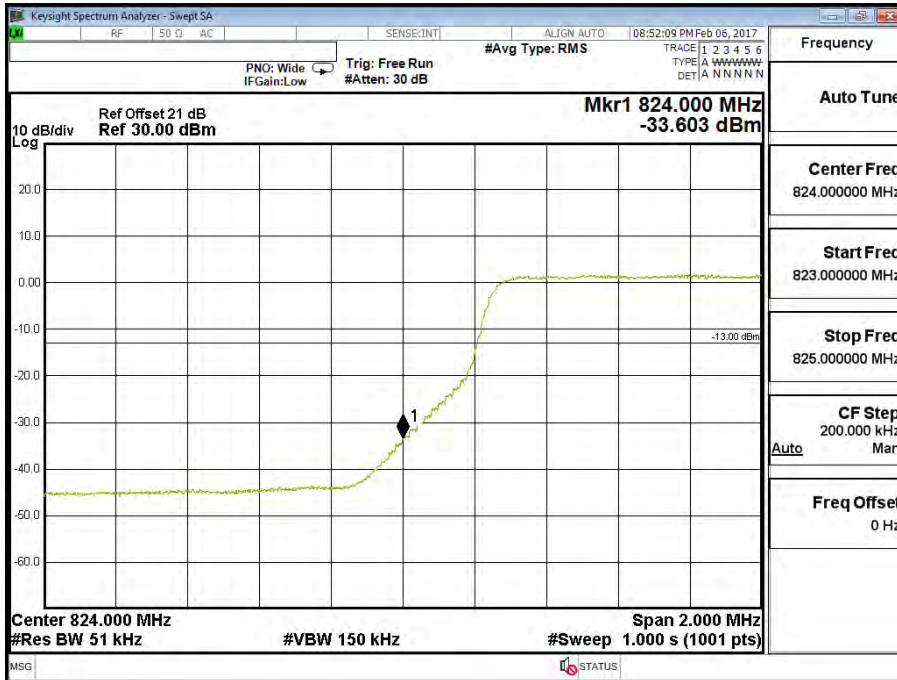

Band 26 (5M) 16QAM(25,0) Upper Channel 27015 (846.5MHz)

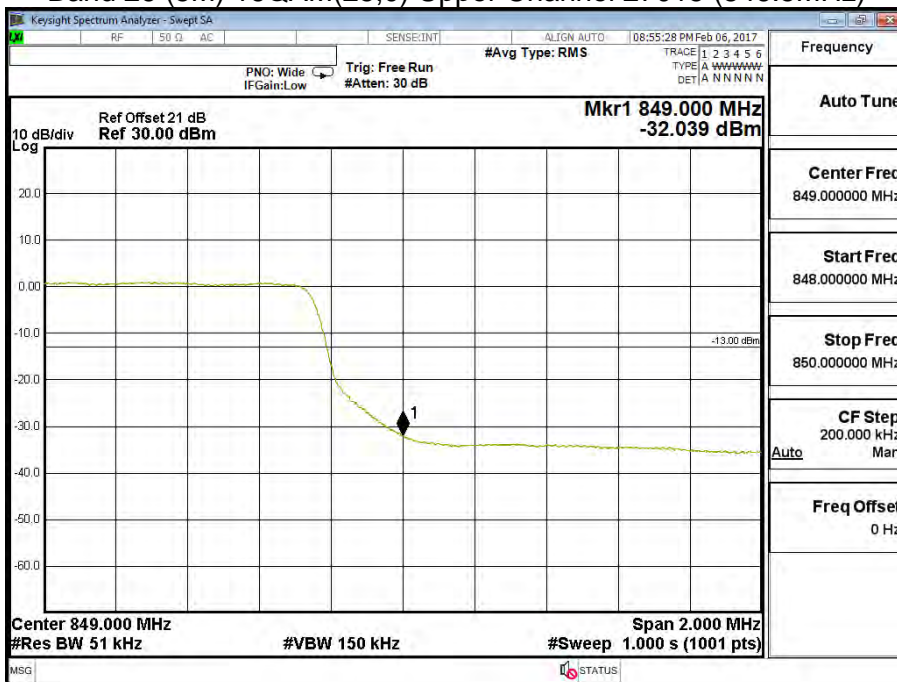

Product	Advanced Industrial 4G/LTE Router, WWAN Failover Manager		
Test Mode	Spurious Emission At Antenna Terminals (+/-1MHz)		
Date of Test	2017/02/06	Test Site	CTR
Test Condition	Block Edge Test (Band 26 (10M))		

Band 26 (10M) QPSK(1,0) Lower Channel 26840 (829MHz)

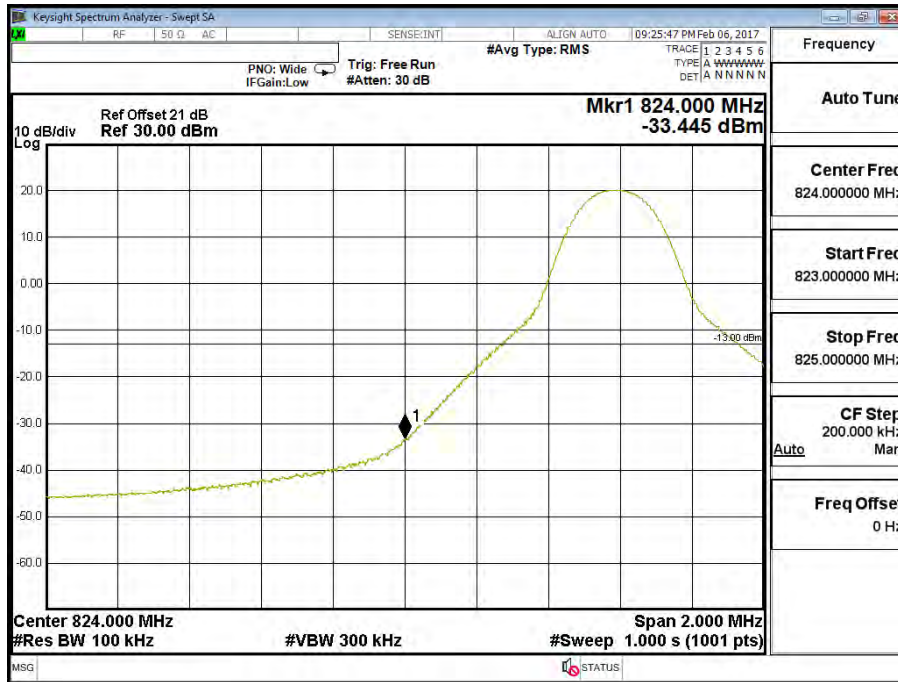

Band 26 (10M) QPSK(1,49) Upper Channel 26990 (844MHz)

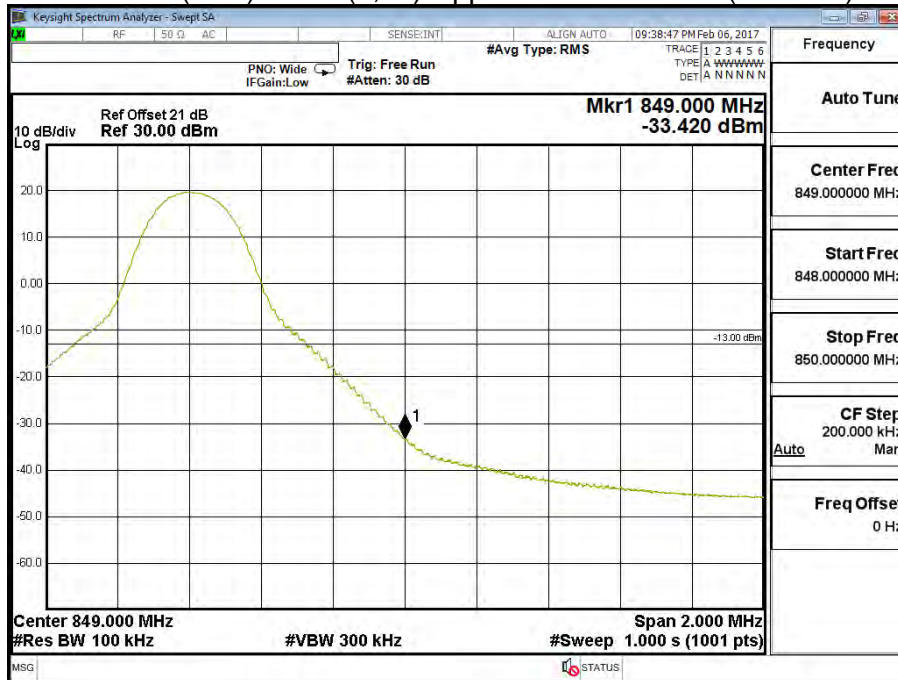

Band 26 (10M) QPSK(50,0) Lower Channel 26840 (829MHz)

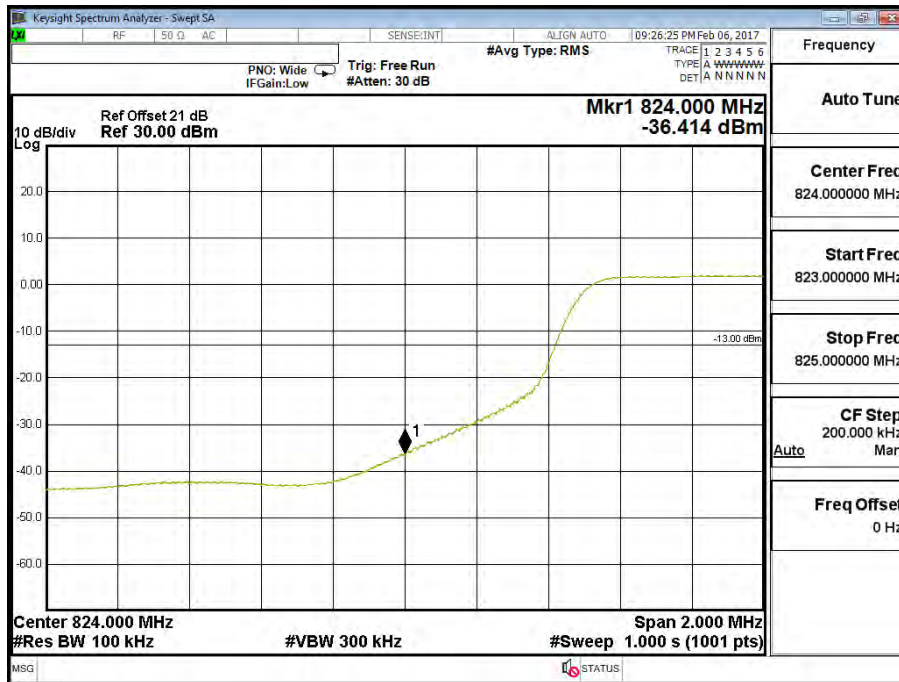

Band 26 (10M) QPSK(50,0) Upper Channel 26990 (844MHz)

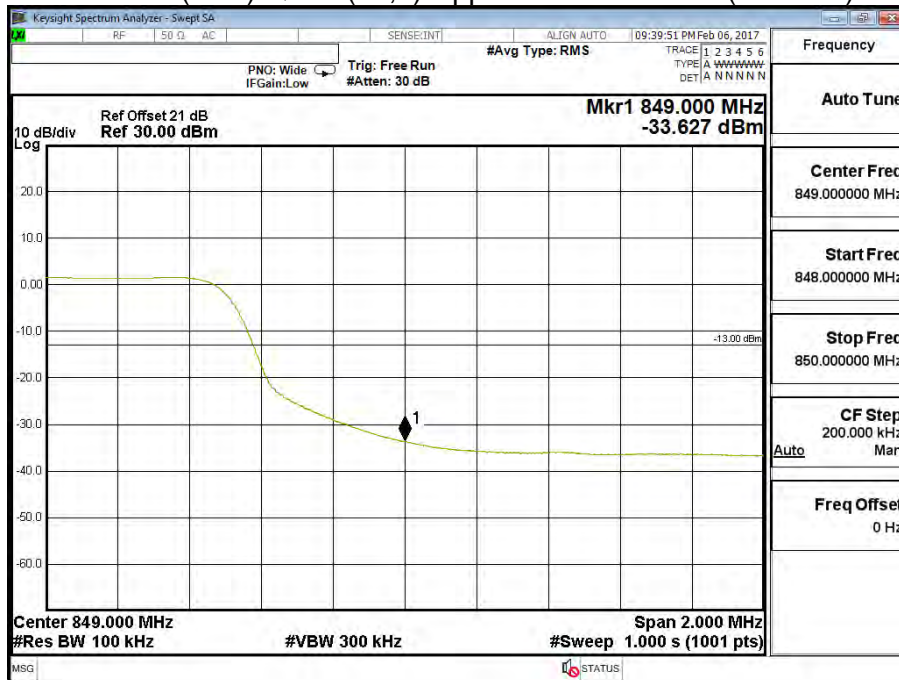

Band 26 (10M) 16QAM(1,0) Lower Channel 26840 (829MHz)

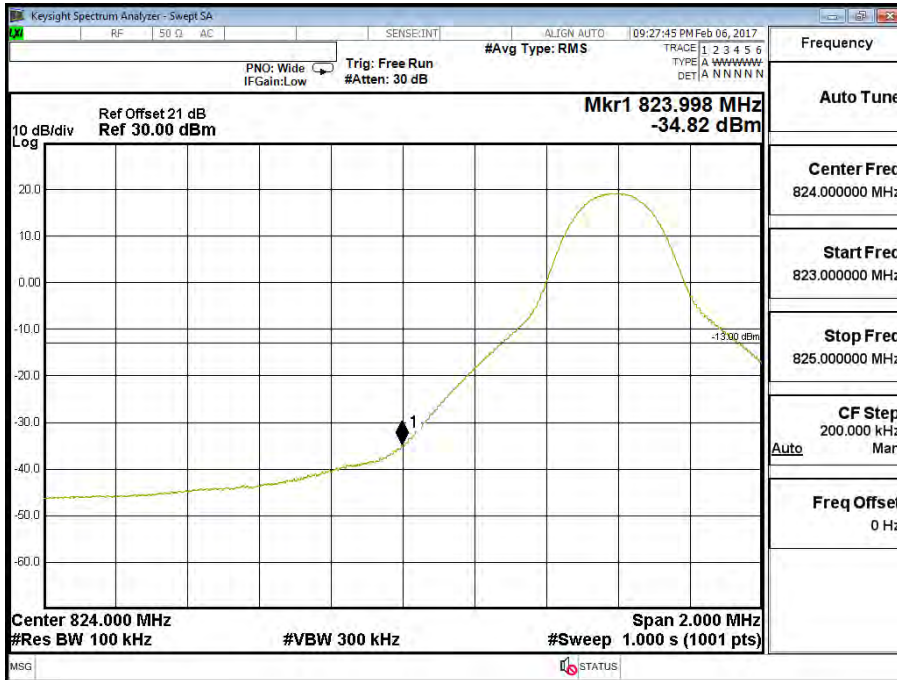

Band 26 (10M) 16QAM(1,49) Upper Channel 26990 (844MHz)

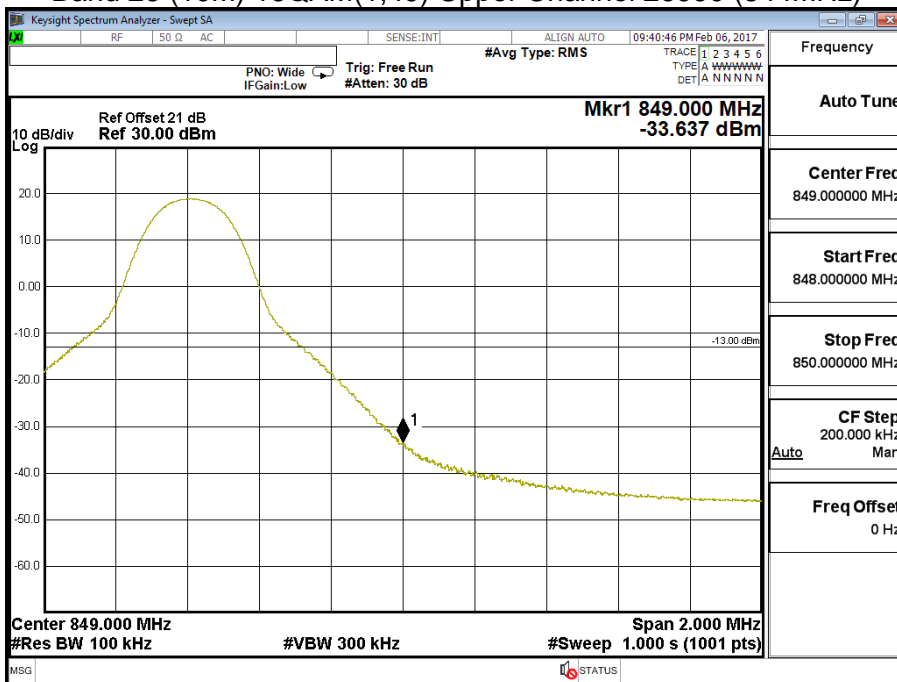

Band 26 (10M) 16QAM(50,0) Lower Channel 26840 (829MHz)

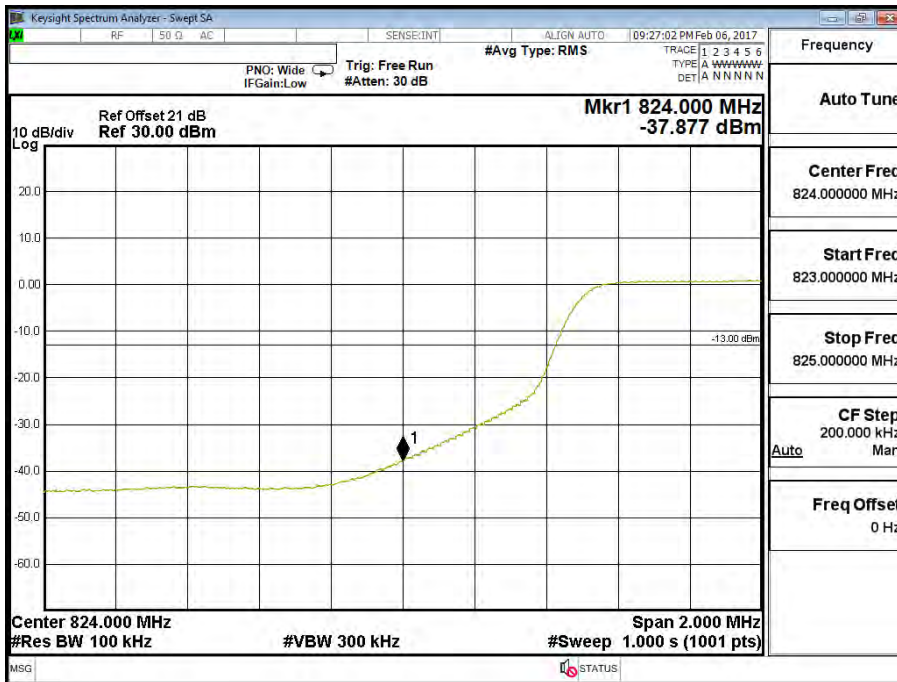

Band 26 (10M) 16QAM(50,0) Upper Channel 26990 (844MHz)

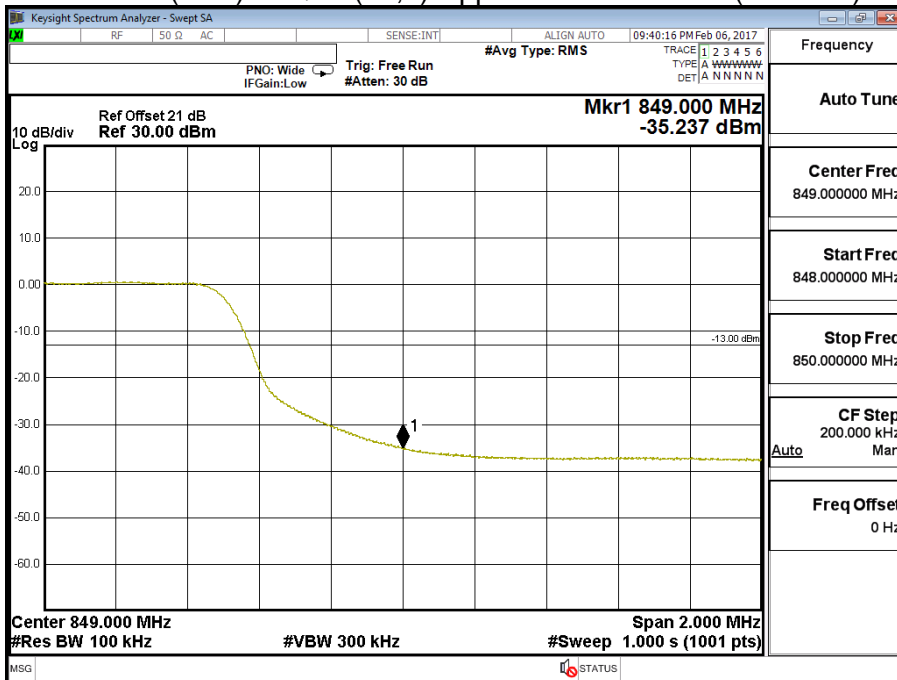

Product	Advanced Industrial 4G/LTE Router, WWAN Failover Manager		
Test Mode	Spurious Emission At Antenna Terminals (+/-1MHz)		
Date of Test	2017/02/06	Test Site	CTR
Test Condition	Block Edge Test (Band 26 (15M))		

Band 26 (15M) QPSK(1,0) Lower Channel 26865 (831.5MHz)

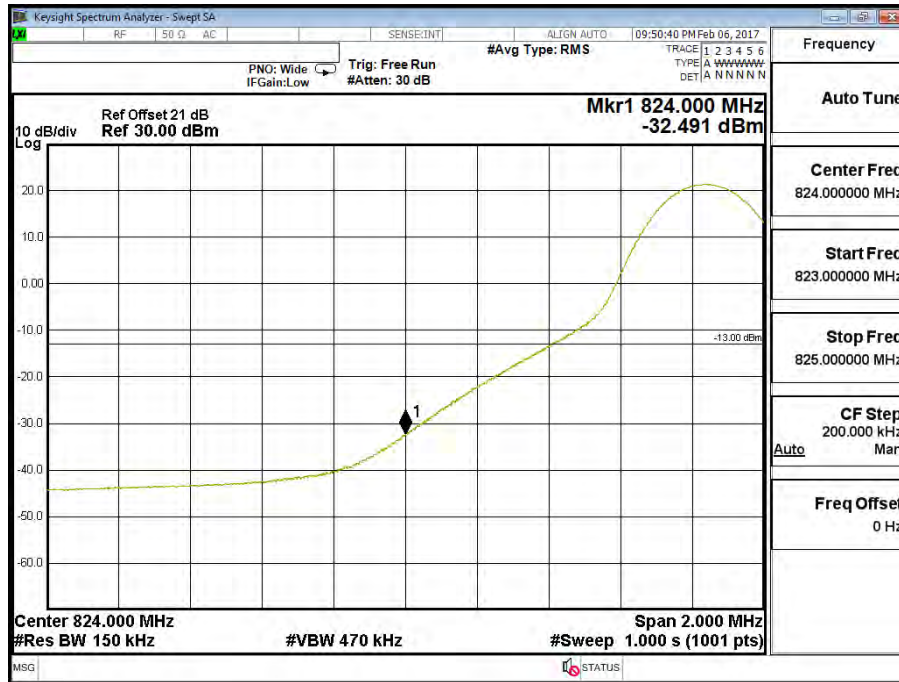

Band 26 (15M) QPSK(1,74) Upper Channel 26965 (841.5MHz)



Band 26 (15M) QPSK(75,0) Lower Channel 26865 (831.5MHz)

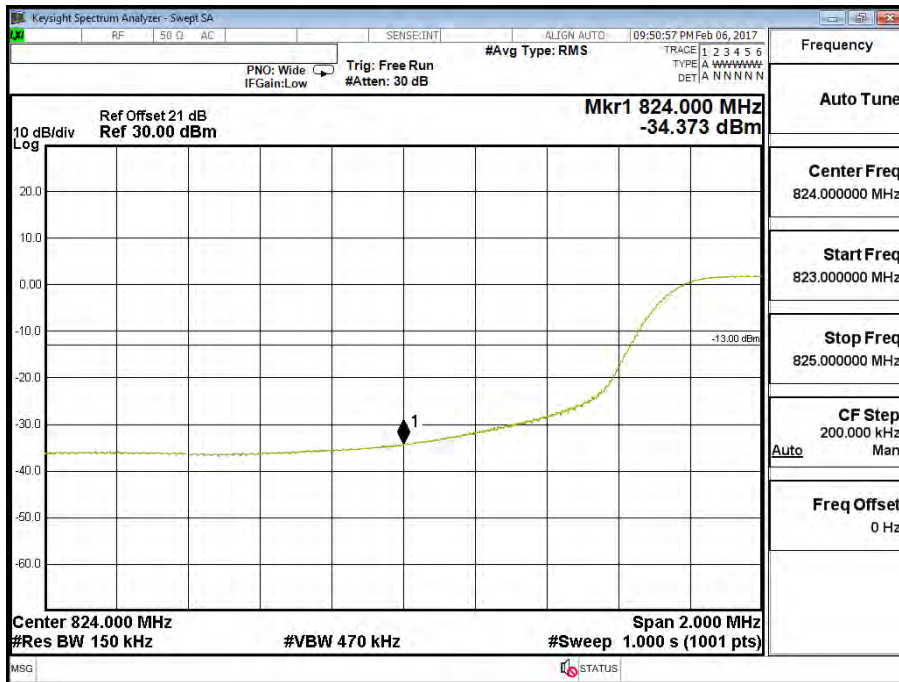

Band 26 (15M) QPSK(75,0) Upper Channel 26965 (841.5MHz)

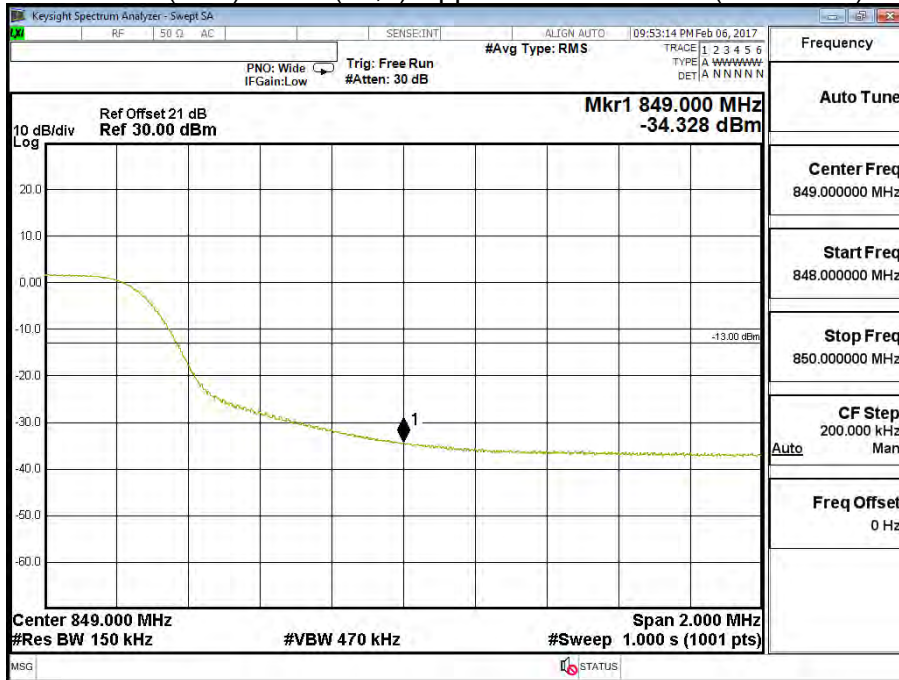

Band 26 (15M) 16QAM(1,0) Lower Channel 26865 (831.5MHz)

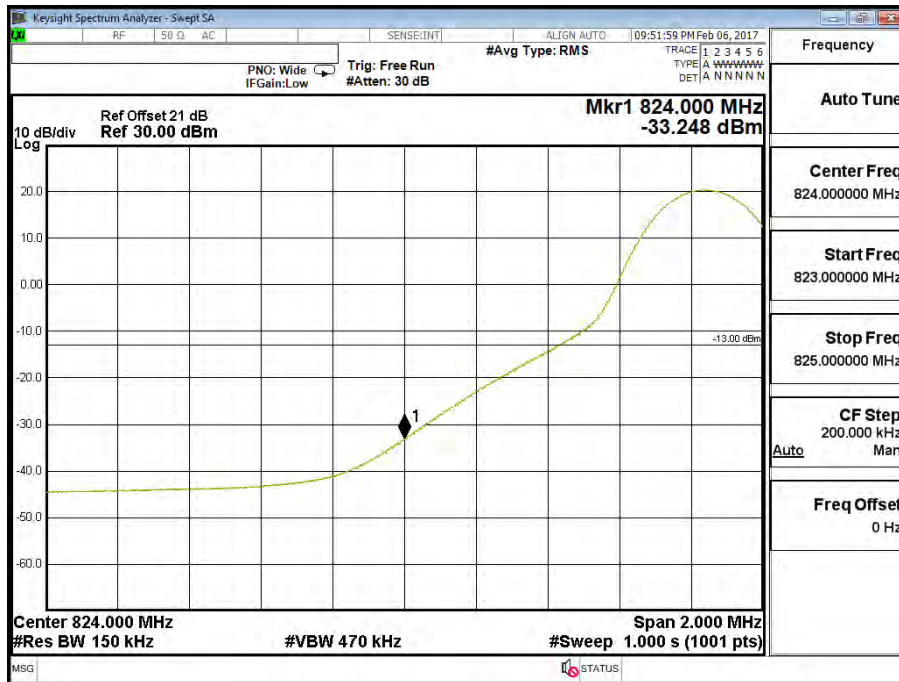

Band 26 (15M) 16QAM(1,74) Upper Channel 26965 (841.5MHz)



Band 26 (15M) 16QAM(75,0) Lower Channel 26865 (831.5MHz)

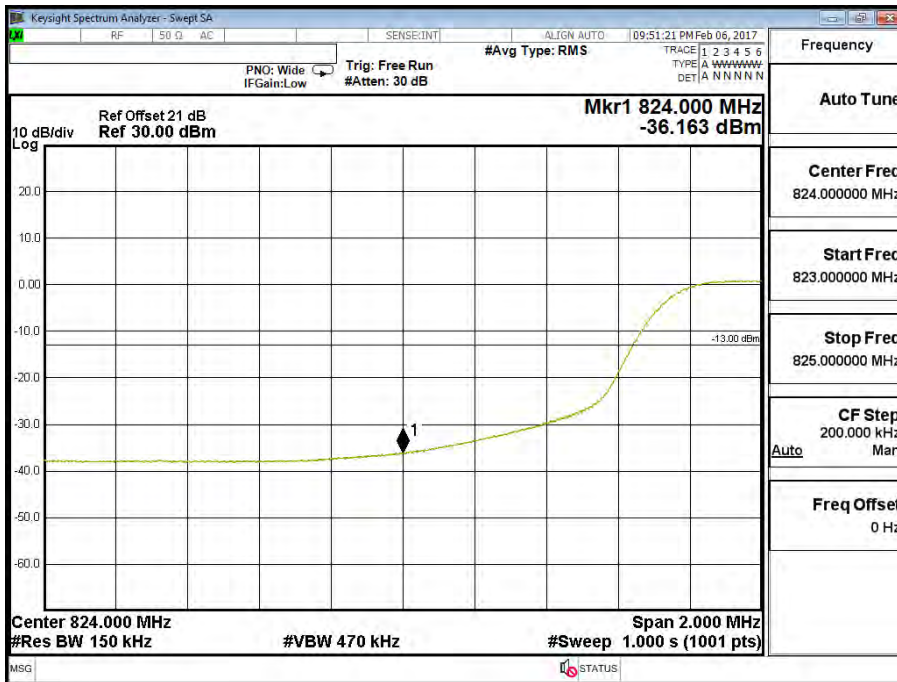

Band 26 (15M) 16QAM(75,0) Upper Channel 26965 (841.5MHz)

