

# FCC RADIO TEST REPORT

## FCC 47 CFR PART 27

<b>Test Standard</b>	<b>FCC Part 27</b>
<b>FCC ID</b>	<b>QI3BIL-7820NZ-4G</b>
<b>Product name</b>	<b>3G/4G LTE Embedded with Dual-SIM Slots ADSL2+ Wireless-N VPN Firewall Router</b>
<b>Brand name</b>	<b>BILLION, BEC</b>
<b>Test Result</b>	<b>Pass</b>
<b>Function</b>	<b>LTE Band 4</b>

The test Result was tested by Compliance Certification Services Inc. The test data, data evaluation, test procedures, and equipment configurations shown in this report were given in TIA/EIA-603D:2012 and compliance standards.

The test results of this report relate only to the tested sample (EUT) identified in this report.

The test Report of full or partial shall not copy. Without written approval of Compliance Certification Services Inc.( Wugu Laboratory)

The sample selected for test was production product and was provided by manufacturer.



Approved by:

Reviewed by:

Handwritten signature of Sam Chuang in black ink.

Handwritten signature of Zeus Chen in black ink.

---

Sam Chuang  
Manager

---

Zeus Chen  
Supervisor

## Revision History

Rev.	Issue Date	Revisions	Revised By
00	January 18, 2017	Initial Issue	Angel Cheng
01	March 24, 2017	1. Modify antenna gain in page 6.	Angel Cheng
02	April 25, 2017	1. Modify EIRP data in page 21-22. 2. Modify Bandedge data in page 39-50.	Angel Cheng
03	May 03, 2017	1. Add 16QAM Frequency Stability	Angel Cheng

## Table of contents

<b>1. GENERAL INFORMATION .....</b>	<b>4</b>
<b>1.1 EUT INFORMATION .....</b>	<b>4</b>
<b>1.2 EUT CHANNEL INFORMATION .....</b>	<b>7</b>
<b>1.3 EMISSION DESIGNATOR.....</b>	<b>7</b>
<b>1.4 ANTENNA INFORMATION .....</b>	<b>8</b>
<b>1.5 MEASUREMENT UNCERTAINTY.....</b>	<b>9</b>
<b>1.6 FACILITIES AND TEST LOCATION .....</b>	<b>10</b>
<b>1.7 INSTRUMENT CALIBRATION .....</b>	<b>10</b>
<b>1.8 SUPPORT AND EUT ACCESSORIES EQUIPMENT .....</b>	<b>11</b>
<b>1.9 TEST METHODOLOGY AND APPLIED STANDARDS .....</b>	<b>11</b>
<b>1.10 TABLE OF ACCREDITATIONS AND LISTINGS .....</b>	<b>11</b>
<b>2. DESCRIPTION OF TEST MODES .....</b>	<b>12</b>
<b>2.1 THE WORST MODE OF OPERATING CONDITION .....</b>	<b>12</b>
<b>2.2 THE WORST MODE OF MEASUREMENT .....</b>	<b>13</b>
<b>3. TEST RESULT .....</b>	<b>14</b>
<b>3.1 OUTPUT POWER MEASUREMENT .....</b>	<b>14</b>
<b>3.2 OCCUPIED BANDWIDTH(99%).....</b>	<b>23</b>
<b>3.3 PEAK TO AVERAGE POWER RATIO .....</b>	<b>31</b>
<b>3.4 BANDEDGE MEASURMENT .....</b>	<b>38</b>
<b>3.5 CONDUCTED SPURIOUS EMISSION .....</b>	<b>51</b>
<b>3.6 RADIATION EMISSION.....</b>	<b>64</b>
<b>3.7 FREQUENCY STABILITY .....</b>	<b>84</b>

### APPENDIX 1 - PHOTOGRAPHS OF EUT

# 1. GENERAL INFORMATION

## 1.1 EUT INFORMATION

Applicant	Billion Electric Co., Ltd.			
Applicant Address	8F., No.192, Sec. 2, Zhongxing Rd., Xindian Dist., New Taipei City 231, Taiwan (R.O.C.)			
Equipment	3G/4G LTE Embedded with Dual-SIM Slots ADSL2+ Wireless-N VPN Firewall Router			
Model No.	BiPAC 7820NZ	BiPAC 7820NZL	BiPAC6820NZ	BiPAC 6820NZL
	BEC 7820NZ	BEC 7820NZL	BEC 6820NZ	BEC 6820NZL
	BiPAC 7800NZ	BiPAC 7800NZL	BiPAC6800NZ	BiPAC 6800NZL
	BEC 7800NZ	BEC 7800NZL	BEC 6800NZ	BEC 6800NZL
EUT Functions	LTE Band 4			
Received Date	Dec 19, 2016			
Date of Test	Dec 27, 2016 ~ April 11, 2017			
Power Operation	<input checked="" type="checkbox"/> AC 120V/60Hz <input checked="" type="checkbox"/> Adapter <input type="checkbox"/> PoE(Not for sale) <input type="checkbox"/> DC Type : <input type="checkbox"/> Battery <input type="checkbox"/> DC Power Supply <input type="checkbox"/> External DC adapter			

**Model Discrepancy:**

Model Name	BiPAC 7820NZ	BiPAC 7820NZL	BiPAC 6820NZ	BiPAC 6820NZL	BEC 7820NZ	BEC 7820NZL
Trade Name	Billion	Billion	Billion	Billion	BEC	BEC
External Feature	Wide-band Antenna	Wide-band Antenna	Wide-band Antenna	Wide-band Antenna	Wide-band Antenna	Wide-band Antenna
External Color	Upper/lower Casing: blue/white	Upper/lower Casing: blue/white	Upper/lower Casing: blue/white	Upper/lower Casing: blue/white	Upper/lower Casing: gray/silver	Upper/lower Casing: gray/silver
Housing Drawing	D3-1	D3-1	D3-1	D3-1	D3-1	D3-1
Dual-SIM Slots	○	○	○	○	○	○
VPN	○	×	○	×	○	×
ADSL Function	○	○	×	×	○	○
Power Adaptor	DC12V/1.2A	DC12V/1.2A	DC12V/1.2A	DC12V/1.2A	DC12V/1.2A	DC12V/1.2A

**Notes:**

1. " O " means all the same
2. Please refer to the difference between the actual product differences in the case of changes in the instructions.
3. N represents the models support 802.11n, there are Z represents the 4G LTE Function.

Model Name	BEC 6820NZ	BEC 6820NZL	BiPAC 7800NZ	BiPAC 7800NZL	BiPAC 6800NZ	BiPAC 6800NZL
Trade Name	BEC	BEC	Billion	Billion	Billion	Billion
External Feature	Wide-band Antenna	Wide-band Antenna	Wide-band Antenna	Wide-band Antenna	Wide-band Antenna	Wide-band Antenna
External Color	Upper/lower Casing: gray/silver	Upper/lower Casing: gray/silver	Upper/lower Casing: blue/white	Upper/lower Casing: blue/white	Upper/lower Casing: blue/white	Upper/lower Casing: blue/white
Housing Drawing	D3-1	D3-1	D3-1	D3-1	D3-1	D3-1
Dual-SIM Slots	○	○	×	×	×	×
VPN	○	×	○	×	○	×
ADSL Function	×	×	○	○	×	×
Power Adaptor	DC12V/1.2A	DC12V/1.2A	DC12V/1.2A	DC12V/1.2A	DC12V/1.2A	DC12V/1.2A

**Notes:**

1. " O " means all the same
2. Please refer to the difference between the actual product differences in the case of changes in the instructions.
3. N represents the models support 802.11n, there are Z represents the 4G LTE Function.

Model Name	BEC 7800NZ	BEC 7800NZL	BEC 6800NZ	BEC 6800NZL		
Trade Name	BEC	BEC	BEC	BEC		
External Feature	Wide-band Antenna	Wide-band Antenna	Wide-band Antenna	Wide-band Antenna		
External Color	Upper/lower Casing: gray/silver	Upper/lower Casing: gray/silver	Upper/lower Casing: gray/silver	Upper/lower Casing: gray/silver		
Housing Drawing	D3-1	D3-1	D3-1	D3-1		
Dual-SIM Slots	×	×	×	×		
VPN	○	×	○	×		
ADSL Function	○	○	×	×		
Power Adaptor	DC12V/1.2A	DC12V/1.2A	DC12V/1.2A	DC12V/1.2A		

**Notes:**

1. " O " means all the same
2. Please refer to the difference between the actual product differences in the case of changes in the instructions.
3. N represents the models support 802.11n, there are Z represents the 4G LTE Function.

## 1.2 EUT CHANNEL INFORMATION

Frequency Range						
Channel	1.4MHz		3MHz		5MHz	
	Channel	Frequency (MHz)	Channel	Frequency (MHz)	Channel	Frequency (MHz)
Low CH	19957	1710.7	19965	1711.5	19975	1712.5
Middle CH	20175	1732.5	20175	1732.5	20175	1732.5
High CH	20392	1754.2	20384	1753.4	20375	1752.5
Channel	10MHz		15MHz		20MHz	
	Channel	Frequency (MHz)	Channel	Frequency (MHz)	Channel	Frequency (MHz)
Low CH	20000	1715.0	20025	1717.5	20050	1720.0
Middle CH	20175	1732.5	20175	1732.5	20175	1732.5
High CH	20350	1750.0	20325	1747.5	20300	1745.0

## 1.3 EMISSION DESIGNATOR

Emission Designator						
Band	Frequency Range(MHz)	BW (MHz)	QPSK		16QAM	
			Emission Designator	Maximum EIRP (W)	Emission Designator	Maximum EIRP (W)
4	1710.7MHz ~1754.2MHz	1.4	1M08G7D	0.519	1M08W7D	0.500
	1711.5MHz ~1753.4MHz	3	2M67G7D	0.473	2M68W7D	0.537
	1712.5MHz ~1752.5MHz	5	4M45G7D	0.485	4M45W7D	0.492
	1715.0MHz ~1750.0MHz	10	8M91G7D	0.505	8M91W7D	0.539
	1717.5MHz ~1747.50MHz	15	13M4G7D	0.487	13M4W7D	0.497
	1720MHz ~1745MHz	20	18M0G7D	0.474	18M0W7D	0.467

## 1.4 ANTENNA INFORMATION

<b>Antenna Category</b>	<input type="checkbox"/> Integral: antenna permanently attached <input type="checkbox"/> External dedicated antennas <input checked="" type="checkbox"/> External Unique antenna connector
<b>Antenna Type</b>	<input type="checkbox"/> PIFA <input type="checkbox"/> PCB for <input checked="" type="checkbox"/> Dipole <input type="checkbox"/> Printed <input type="checkbox"/> Coils
<b>Antenna Gain</b>	2.26 (dBi)



## 1.5 MEASUREMENT UNCERTAINTY

PARAMETER	UNCERTAINTY
AC Powerline Conducted Emission	+/- 1.2575
Emission bandwidth, 20dB bandwidth	+/- 1.4003
RF output power, conducted	+/- 1.1372
Power density, conducted	+/- 1.4003
3M Semi Anechoic Chamber / 30M~200M	+/- 4.0138
3M Semi Anechoic Chamber / 200M~1000M	+/- 3.9483
3M Semi Anechoic Chamber / 1G~8G	+/- 2.5975
3M Semi Anechoic Chamber / 8G~18G	+/- 2.6112
3M Semi Anechoic Chamber / 18G~26G	+/- 2.7389
3M Semi Anechoic Chamber / 26G~40G	+/- 2.9683
3M Semi Anechoic Chamber / 40G~60G	+/- 1.8509
3M Semi Anechoic Chamber / 60G~75G	+/- 1.9869
3M Semi Anechoic Chamber / 75G~110G	+/- 2.9651
3M Semi Anechoic Chamber / 110G~170G	+/- 2.7807
3M Semi Anechoic Chamber / 170G~220G	+/- 3.6437
3M Semi Anechoic Chamber / 220G~325G	+/- 4.2982

**Remark:**

1. This uncertainty represents an expanded uncertainty expressed at approximately the 95% confidence level using a coverage factor of  $k=2$
2. ISO/IEC 17025 requires that an estimate of the measurement uncertainties associated with the emissions test results be included in the report.

## 1.6 FACILITIES AND TEST LOCATION

All measurement facilities used to collect the measurement data are located at  
No. 11, Wugong 6th Rd., Wugu Dist., New Taipei City 24891, Taiwan. (R.O.C.)

Test site	Test Engineer	Remark
AC Conduction Room	-	-
Radiation	Rondo Raw	-
RF Conducted	Ian Tu	-

**Remark:** The sites are constructed in conformance with the requirements of ANSI C63.7, ANSI C63.4 and CISPR Publication 22.

## 1.7 INSTRUMENT CALIBRATION

RF Conducted Test Site					
Equipment	Manufacturer	Model	S/N	Cal Date	Cal Due
Spectrum Analyzer	R&S	FSV 40	101073	05/11/2016	05/10/2017
Communication Analyzer	Anritsu	MT-8820C	6201240043	02/18/2016	02/17/2017
Communication Analyzer	Anritsu	MT-8820C	6200938900	07/26/2017	07/25/2017

3M 966 Chamber Test Site					
Equipment	Manufacturer	Model	S/N	Cal Date	Cal Due
Spectrum Analyzer	Agilent	E4446A	US42510252	12/07/2016	12/04/2017
Loop Ant	COM-POWER	AL-130	121051	02/25/2016	02/24/2017
Bilog Antenna	Sunol Sciences	JB3	A030105	07/03/2016	07/02/2017
Pre-Amplifier	EMEC	EM330	60609	06/08/2016	06/07/2017
Horn Antenna	ETC	MCTD 1209	DRH13M02003	08/30/2016	09/01/2017
Pre-Amplifier	MITEQ	AMF-6F-260400-40-8P	985646	01/14/2016	01/13/2017
Horn Antenna	EMCO	3116	26370	01/15/2016	01/14/2017
Antenna Tower	CCS	CC-A-1F	N/A	N.C.R	N.C.R
Controller	CCS	CC-C-1F	N/A	N.C.R	N.C.R
Turn Table	CCS	CC-T-1F	N/A	N.C.R	N.C.R
Software	EZ-EMC (CCS-3A1RE)				

**Remark:** Each piece of equipment is scheduled for calibration once a year.

## 1.8 SUPPORT AND EUT ACCESSORIES EQUIPMENT



EUT Accessories Equipment					
No.	Equipment	Brand	Model	Series No.	FCC ID
1	Adapter	Ktec	KSASB0241500160HU	N/A	N/A

Support Equipment					
No.	Equipment	Brand	Model	Series No.	FCC ID
	N/A				

## 1.9 TEST METHODOLOGY AND APPLIED STANDARDS

The test methodology, setups and results comply with all requirements in accordance with TIA/EIA-603-D:2010 and Part 27.

## 1.10 TABLE OF ACCREDITATIONS AND LISTINGS

Country	Agency	Scope of Accreditation	Logo
USA	FCC	3M Semi Anechoic Chamber (FCC MRA: TW1039) to perform FCC Part 15 measurements	 FCC MRA: TW1039
Canada	Industry Canada	3M Semi Anechoic Chamber (IC 2324G-1 / IC 2324G-2) to perform	 IC 2324G-1 IC 2324G-2

## 2. DESCRIPTION OF TEST MODES

### 2.1 THE WORST MODE OF OPERATING CONDITION

Operation mode	Channel	1.4MHz		3MHz		5MHz	
		Channel	Frequency (MHz)	Channel	Frequency (MHz)	Channel	Frequency (MHz)
	Low CH	19957	1710.7	19965	1711.5	19975	1712.5
	Middle CH	20175	1732.5	20175	1732.5	20175	1732.5
	High CH	20392	1754.2	20384	1753.4	20375	1752.5
Operation mode	Channel	10MHz		15MHz		20MHz	
		Channel	Frequency (MHz)	Channel	Frequency (MHz)	Channel	Frequency (MHz)
	Low CH	20000	1715.0	20025	1717.5	20050	1720.0
	Middle CH	20175	1732.5	20175	1732.5	20175	1732.5
	High CH	20350	1750.0	20325	1747.5	20300	1745.0

*Remark:*

- 1. EUT pre-scanned the output power for each mode, the worst data rate were recorded in this report.*
- 2. Client consigns only one model sample to test (Model Number: BiPAC 7820NZ).*

## 2.2 THE WORST MODE OF MEASUREMENT

Radiated Emission Measurement Above 1G	
Test Condition	Band edge, Emission for Unwanted and Fundamental
Voltage/Hz	120V/60Hz
Test Mode	Mode 1:EUT power by AC adapter
Worst Mode	<input checked="" type="checkbox"/> Mode 1 <input type="checkbox"/> Mode 2 <input type="checkbox"/> Mode 3 <input type="checkbox"/> Mode 4
Worst Position	<input type="checkbox"/> Placed in fixed position. <input type="checkbox"/> Placed in fixed position at X-Plane (E2-Plane) <input checked="" type="checkbox"/> Placed in fixed position at Y-Plane (E1-Plane) <input type="checkbox"/> Placed in fixed position at Z-Plane (H-Plane)
Worst Polarity	<input checked="" type="checkbox"/> Horizontal <input type="checkbox"/> Vertical

Radiated Emission Measurement Below 1G	
Test Condition	Radiated Emission Below 1G
Voltage/Hz	120V/60Hz
Test Mode	Mode 1:EUT power by AC adapter
Worst Mode	<input checked="" type="checkbox"/> Mode 1 <input type="checkbox"/> Mode 2 <input type="checkbox"/> Mode 3 <input type="checkbox"/> Mode 4

**Remark:**

1. The worst mode was record in this test report.
2. EUT pre-scanned in three axis, X, Y, Z and two polarity, Horizontal and Vertical for radiated measurement. The worst case(X-Plane and Horizontal) were recorded in this report.
3. For below 1G AC power line conducted emission and radiation emission were performed the EUT transmit at the highest output power channel as worse case.

### **3. TEST RESULT**

#### **3.1 OUTPUT POWER MEASUREMENT**

##### **3.1.1 Test Procedure**

Conducted Power Measurement

1. The transmitter output power was connected to the call box.
2. Set EUT at maximum output power via call box.
3. Set Call box at lowest, middle and highest channels for each band and modulation.

##### **3.1.2 Test Result**

**LTE Band 4**

Band	BW (MHz)	Channel	Frequency (MHz)	Mode	UL RB Allocation	UL RB Offset	MPR	Average Power (dBm)	Average Power (W)
4	1.4	19957	1710.7	QPSK	1	0	0	22.5	0.1778
					1	2	0	22.4	0.1738
					1	5	0	22.3	0.1698
					3	0	0	22.7	0.1862
					3	1	0	22.4	0.1738
					3	2	0	22.3	0.1698
				6	0	1	21.5	0.1413	
				16QAM	1	0	1	21.8	0.1514
					1	2	1	21.6	0.1445
		1	5		1	21.5	0.1413		
		3	0		1	21.8	0.1514		
		3	1		1	21.6	0.1445		
		3	2		1	21.5	0.1413		
		6	0	2	20.5	0.1122			
		20175	1732.5	QPSK	1	0	0	22.5	0.1778
					1	2	0	22.3	0.1698
					1	5	0	22.3	0.1698
					3	0	0	22.5	0.1778
	3				1	0	22.3	0.1698	
	3				2	0	22.3	0.1698	
	6			0	1	21.4	0.1380		
	16QAM			1	0	1	21.5	0.1413	
				1	2	1	21.5	0.1413	
		1	5	1	21.4	0.1380			
		3	0	1	21.5	0.1413			
		3	1	1	21.5	0.1413			
		3	2	1	21.4	0.1380			
6	0	2	20.5	0.1122					
20392	1754.2	QPSK	1	0	0	22.6	0.1820		
			1	2	0	22.4	0.1738		
			1	5	0	22.4	0.1738		
			3	0	0	22.6	0.1820		
			3	1	0	22.4	0.1738		
			3	2	0	22.4	0.1738		
			6	0	1	21.5	0.1413		
		16QAM	1	0	1	21.6	0.1445		
			1	2	1	21.5	0.1413		
			1	5	1	21.5	0.1413		
			3	0	1	21.6	0.1445		
			3	1	1	21.5	0.1413		
			3	2	1	21.5	0.1413		
			6	0	2	20.6	0.1148		

**LTE Band 4**

Band	BW (MHz)	Channel	Frequency (MHz)	Mode	UL RB Allocation	UL RB Offset	MPR	Average Power (dBm)	Average Power (W)		
4	3	19965	1711.5	QPSK	1	0	0	22.5	0.1778		
					1	7	0	22.4	0.1738		
					1	14	0	22.3	0.1698		
					8	0	1	21.8	0.1514		
					8	4	1	21.6	0.1445		
					8	7	1	21.6	0.1445		
				16QAM	15	0	1	21.5	0.1413		
					1	0	1	21.8	0.1514		
					1	7	1	21.6	0.1445		
					1	14	1	21.5	0.1413		
					8	0	2	20.8	0.1202		
					8	4	2	20.6	0.1148		
		20175	1732.5	QPSK	1732.5	QPSK	8	7	1	21.6	0.1445
							8	0	1	21.7	0.1479
							8	4	1	21.5	0.1413
							8	7	1	21.5	0.1413
							15	0	1	21.4	0.1380
							1	0	0	22.5	0.1778
				16QAM	1	7	1	21.5	0.1413		
					1	14	1	21.4	0.1380		
					8	0	2	20.6	0.1148		
					8	4	2	20.4	0.1096		
					8	7	2	20.5	0.1122		
					15	0	2	20.4	0.1096		
		20384	1753.4	QPSK	1753.4	QPSK	1	0	0	22.6	0.1820
							1	7	0	22.4	0.1738
							1	14	0	22.4	0.1738
							8	0	1	21.7	0.1479
							8	4	1	21.6	0.1445
							8	7	1	21.6	0.1445
16QAM	15			0	1	21.5	0.1413				
	1			0	1	21.6	0.1445				
	1			7	1	21.5	0.1413				
	1			14	1	21.5	0.1413				
	8			0	2	20.7	0.1175				
	8			4	2	20.6	0.1148				
8	7	2	20.6	0.1148							
15	0	2	20.5	0.1122							



**LTE Band 4**

Band	BW (MHz)	Channel	Frequency (MHz)	Mode	UL RB Allocation	UL RB Offset	MPR	Average Power (dBm)	Average Power (W)
4	5	19975	1712.5	QPSK	1	0	0	22.6	0.1820
					1	12	0	22.5	0.1778
					1	24	0	22.4	0.1738
					12	0	1	21.9	0.1549
					12	6	1	21.7	0.1479
					12	11	1	21.7	0.1479
					25	0	1	21.6	0.1445
				16QAM	1	0	1	21.9	0.1549
					1	12	1	21.7	0.1479
					1	24	1	21.6	0.1445
					12	0	2	20.9	0.1230
					12	6	2	20.7	0.1175
					12	11	2	20.7	0.1175
					25	0	2	20.6	0.1148
		20175	1732.5	QPSK	1	0	0	22.6	0.1820
					1	12	0	22.4	0.1738
					1	24	0	22.4	0.1738
					12	0	1	21.8	0.1514
					12	6	1	21.6	0.1445
					12	11	1	21.6	0.1445
					25	0	1	21.5	0.1413
				16QAM	1	0	1	21.6	0.1445
					1	12	1	21.6	0.1445
					1	24	1	21.5	0.1413
					12	0	2	20.7	0.1175
					12	6	2	20.5	0.1122
					12	11	2	20.6	0.1148
					25	0	2	20.5	0.1122
		20375	1752.5	QPSK	1	0	0	22.7	0.1862
					1	12	0	22.5	0.1778
1	24				0	22.5	0.1778		
12	0				1	21.8	0.1514		
12	6				1	21.7	0.1479		
12	11				1	21.7	0.1479		
25	0				1	21.6	0.1445		
16QAM	1			0	1	21.7	0.1479		
	1			12	1	21.6	0.1445		
	1			24	1	21.6	0.1445		
	12			0	2	20.8	0.1202		
	12			6	2	20.7	0.1175		
	12			11	2	20.7	0.1175		
	25			0	2	20.6	0.1148		

**LTE Band 4**

Band	BW (MHz)	Channel	Frequency (MHz)	Mode	UL RB Allocation	UL RB Offset	MPR	Average Power (dBm)	Average Power (W)
4	10	20000	1715.0	QPSK	1	0	0	22.6	0.1820
					1	24	0	22.5	0.1778
					1	49	0	22.4	0.1738
					25	0	1	21.9	0.1549
					25	12	1	21.7	0.1479
					25	24	1	21.7	0.1479
					50	0	1	21.6	0.1445
				16QAM	1	0	1	21.9	0.1549
					1	24	1	21.7	0.1479
					1	49	1	21.6	0.1445
					25	0	2	20.9	0.1230
					25	12	2	20.7	0.1175
					25	24	2	20.7	0.1175
					50	0	2	20.6	0.1148
		20175	1732.5	QPSK	1	0	0	22.6	0.1820
					1	24	0	22.4	0.1738
					1	49	0	22.4	0.1738
					25	0	1	21.8	0.1514
					25	12	1	21.6	0.1445
					25	24	1	21.6	0.1445
					50	0	1	21.5	0.1413
				16QAM	1	0	1	21.6	0.1445
					1	24	1	21.6	0.1445
					1	49	1	21.5	0.1413
					25	0	2	20.7	0.1175
					25	12	2	20.5	0.1122
					25	24	2	20.6	0.1148
					50	0	2	20.5	0.1122
		20350	1750.0	QPSK	1	0	0	22.7	0.1862
					1	24	0	22.5	0.1778
1	49				0	22.5	0.1778		
25	0				1	21.8	0.1514		
25	12				1	21.7	0.1479		
25	24				1	21.7	0.1479		
50	0				1	21.6	0.1445		
16QAM	1			0	1	21.7	0.1479		
	1			24	1	21.6	0.1445		
	1			49	1	21.6	0.1445		
	25			0	2	20.8	0.1202		
	25			12	2	20.7	0.1175		
	25			24	2	20.7	0.1175		
	50			0	2	20.6	0.1148		

**LTE Band 4**

Band	BW (MHz)	Channel	Frequency (MHz)	Mode	UL RB Allocation	UL RB Offset	MPR	Average Power (dBm)	Average Power (W)
4	15	20025	1717.5	QPSK	1	0	0	22.7	0.1862
					1	37	0	22.6	0.1820
					1	74	0	22.5	0.1778
					36	0	1	22.0	0.1585
					36	18	1	21.8	0.1514
					36	35	1	21.8	0.1514
					75	0	1	21.7	0.1479
				16QAM	1	0	1	22.0	0.1585
					1	37	1	21.8	0.1514
					1	74	1	21.7	0.1479
					36	0	2	21.0	0.1259
					36	18	2	20.8	0.1202
					36	35	2	20.8	0.1202
					75	0	2	20.7	0.1175
		20175	1732.5	QPSK	1	0	0	22.7	0.1862
					1	37	0	22.5	0.1778
					1	74	0	22.5	0.1778
					36	0	1	21.9	0.1549
					36	18	1	21.7	0.1479
					36	35	1	21.7	0.1479
					75	0	1	21.6	0.1445
				16QAM	1	0	1	21.7	0.1479
					1	37	1	21.7	0.1479
					1	74	1	21.6	0.1445
					36	0	2	20.8	0.1202
					36	18	2	20.6	0.1148
					36	35	2	20.7	0.1175
					75	0	2	20.6	0.1148
		20325	1747.5	QPSK	1	0	0	22.8	0.1905
					1	37	0	22.6	0.1820
1	74				0	22.6	0.1820		
36	0				1	21.9	0.1549		
36	18				1	21.8	0.1514		
36	35				1	21.8	0.1514		
75	0				1	21.7	0.1479		
16QAM	1			0	1	21.8	0.1514		
	1			37	1	21.7	0.1479		
	1			74	1	21.7	0.1479		
	36			0	2	20.9	0.1230		
	36			18	2	20.8	0.1202		
	36			35	2	20.8	0.1202		
	75			0	2	20.7	0.1175		

**LTE Band 4**

Band	BW (MHz)	Channel	Frequency (MHz)	Mode	UL RB Allocation	UL RB Offset	MPR	Average Power (dBm)	Average Power (W)				
4	20	20050	1720.0	QPSK	1	0	0	22.7	0.1862				
					1	49	0	22.6	0.1820				
					1	99	0	22.5	0.1778				
					50	0	1	22.0	0.1585				
					50	24	1	21.8	0.1514				
					50	49	1	21.8	0.1514				
				16QAM	100	0	1	21.7	0.1479				
					1	0	1	22.0	0.1585				
					1	49	1	21.8	0.1514				
					1	99	1	21.7	0.1479				
					50	0	2	21.0	0.1259				
					50	24	2	20.8	0.1202				
		20175	1732.5	QPSK	1732.5	QPSK	50	49	2	20.8	0.1202		
							50	0	2	21.0	0.1259		
							50	24	2	20.8	0.1202		
							50	49	2	20.8	0.1202		
							100	0	2	20.7	0.1175		
							100	0	2	20.7	0.1175		
				16QAM	QPSK	1732.5	QPSK	16QAM	1	0	0	22.7	0.1862
									1	49	0	22.5	0.1778
									1	99	0	22.5	0.1778
									50	0	1	21.9	0.1549
									50	24	1	21.7	0.1479
									50	49	1	21.7	0.1479
		20300	1745.0	QPSK	1745.0	QPSK	100	0	1	21.6	0.1445		
							1	0	1	21.7	0.1479		
							1	49	1	21.7	0.1479		
							1	99	1	21.6	0.1445		
							50	0	2	20.8	0.1202		
							50	24	2	20.6	0.1148		
16QAM	QPSK			1745.0	QPSK	16QAM	50	49	2	20.7	0.1175		
							50	0	2	20.8	0.1202		
							50	24	2	20.8	0.1202		
							50	49	2	20.8	0.1202		
							100	0	2	20.6	0.1148		
							100	0	2	20.6	0.1148		
20300	1745.0	QPSK	1745.0	QPSK	1	0	0	22.8	0.1905				
					1	49	0	22.6	0.1820				
					1	99	0	22.6	0.1820				
					50	0	1	21.9	0.1549				
					50	24	1	21.8	0.1514				
					50	49	1	21.8	0.1514				
		16QAM	QPSK	1745.0	QPSK	16QAM	100	0	1	21.7	0.1479		
							1	0	1	21.8	0.1514		
							1	49	1	21.7	0.1479		
							1	99	1	21.7	0.1479		
							50	0	2	20.9	0.1230		
							50	24	2	20.8	0.1202		
16QAM	QPSK	1745.0	QPSK	16QAM	50	49	2	20.8	0.1202				
					50	0	2	20.9	0.1230				
					50	24	2	20.8	0.1202				
					50	49	2	20.8	0.1202				
					100	0	2	20.7	0.1175				
					100	0	2	20.7	0.1175				

**LTE Band 4**

**BW: 1.4MHz / RB=1, RB Offset=0**

Band	BW (MHz)	Channel	Mode	UL RB Allocation	UL RB offset	Vertical		Horizontal	
						EIRP (dBm)	EIRP (W)	EIRP (dBm)	EIRP (W)
4	1.4	Lowest	QPSK	1	0	10.68	0.011	27.16	0.519
		Middle		1	0	10.72	0.011	25.44	0.349
		Highest		1	0	10.46	0.011	26.25	0.421
		Lowest	16 QAM	1	0	10.27	0.010	26.99	0.500
		Middle		1	0	10.12	0.010	25.36	0.343
		Highest		1	0	10.09	0.010	26.22	0.418

**BW: 3MHz / RB=1, RB Offset=0**

Band	BW (MHz)	Channel	Mode	UL RB Allocation	UL RB offset	Vertical		Horizontal	
						EIRP (dBm)	EIRP (W)	EIRP (dBm)	EIRP (W)
4	3	Lowest	QPSK	1	0	10.42	0.011	26.75	0.473
		Middle		1	0	9.67	0.009	25.14	0.326
		Highest		1	0	10.68	0.011	26.42	0.438
		Lowest	16 QAM	1	0	10.40	0.010	27.30	0.537
		Middle		1	0	9.92	0.009	25.01	0.316
		Highest		1	0	10.54	0.011	26.70	0.467

**BW: 5MHz / RB=1, RB Offset=0**

Band	BW (MHz)	Channel	Mode	UL RB Allocation	UL RB offset	Vertical		Horizontal	
						EIRP (dBm)	EIRP (W)	EIRP (dBm)	EIRP (W)
4	5	Lowest	QPSK	1	0	10.39	0.010	26.68	0.465
		Middle		1	0	9.48	0.008	25.12	0.325
		Highest		1	0	11.13	0.012	26.86	0.485
		Lowest	16 QAM	1	0	10.24	0.010	26.92	0.492
		Middle		1	0	9.65	0.009	25.01	0.316
		Highest		1	0	11.17	0.013	26.84	0.483

**BW: 10MHz / RB=1, RB Offset=0**

Band	BW (MHz)	Channel	Mode	UL RB Allocation	UL RB offset	Vertical		Horizontal	
						EIRP (dBm)	EIRP (W)	EIRP (dBm)	EIRP (W)
4	10	Lowest	QPSK	1	0	10.21	0.010	26.98	0.498
		Middle		1	0	9.44	0.008	25.06	0.320
		Highest		1	0	11.45	0.013	27.04	0.505
		Lowest	16 QAM	1	0	10.52	0.011	27.12	0.515
		Middle		1	0	9.44	0.008	24.93	0.311
		Highest		1	0	11.59	0.014	27.32	0.539

**BW: 15MHz / RB=1, RB Offset=0**

Band	BW (MHz)	Channel	Mode	UL RB Allocation	UL RB offset	Vertical		Horizontal	
						EIRP (dBm)	EIRP (W)	EIRP (dBm)	EIRP (W)
4	15	Lowest	QPSK	1	0	9.82	0.009	26.87	0.486
		Middle		1	0	9.55	0.009	24.97	0.314
		Highest		1	0	10.34	0.010	26.88	0.487
		Lowest	16 QAM	1	0	9.76	0.009	26.83	0.481
		Middle		1	0	9.10	0.008	24.86	0.306
		Highest		1	0	10.88	0.012	26.97	0.497

**BW: 20MHz / RB=1, RB Offset=0**

Band	BW (MHz)	Channel	Mode	UL RB Allocation	UL RB offset	Vertical		Horizontal	
						EIRP (dBm)	EIRP (W)	EIRP (dBm)	EIRP (W)
4	20	Lowest	QPSK	1	0	10.22	0.010	26.76	0.474
		Middle		1	0	9.46	0.008	24.98	0.314
		Highest		1	0	10.26	0.010	26.07	0.404
		Lowest	16 QAM	1	0	10.04	0.010	26.70	0.467
		Middle		1	0	9.19	0.008	24.96	0.313
		Highest		1	0	9.85	0.009	26.06	0.403

## 3.2 OCCUPIED BANDWIDTH(99%)

### 3.2.1 Test Limit

**Occupied Bandwidth(99%)** : For reporting purposes only.

### 3.2.2 Test Procedure

KDB 971168 D01 v02r02 - Section 4..2,

1. The occupied bandwidth was measured with the spectrum analyzer at the lowest, middle and highest channels in each band and different modulation. The 99% and -26dB bandwidth was measured and recorded.
2. RBW = 1-5% of the expected OBW, VBW  $\geq$  3 x RBW, Detector = Peak, Trace mode = max. hold

### 3.2.3 Test Setup



### 3.2.4 Test Result

#### LTE Band 4

Band	BW (MHz)	Channel	Mode	UL RB Allocation	UL RB offset	OBW(99%)(MHz)	26 dB Bandwidth(MHz)
4	1.4	Middle	QPSK	6	0	1.0897	1.2808
		Middle	16QAM	6	0	1.0897	1.2721
	3	Middle	QPSK	15	0	2.6743	2.9609
		Middle	16QAM	15	0	2.6830	2.9783
	5	Middle	QPSK	25	0	4.4573	4.8050
		Middle	16QAM	25	0	4.4573	4.7900
	10	Middle	QPSK	50	0	8.9146	9.3490
		Middle	16QAM	50	0	8.9146	9.4970
	15	Middle	QPSK	75	0	13.4587	14.7610
		Middle	16QAM	75	0	13.4159	14.8910
	20	Middle	QPSK	100	0	18.0028	19.2220
		Middle	16QAM	100	0	18.0028	19.2800



# Test Data

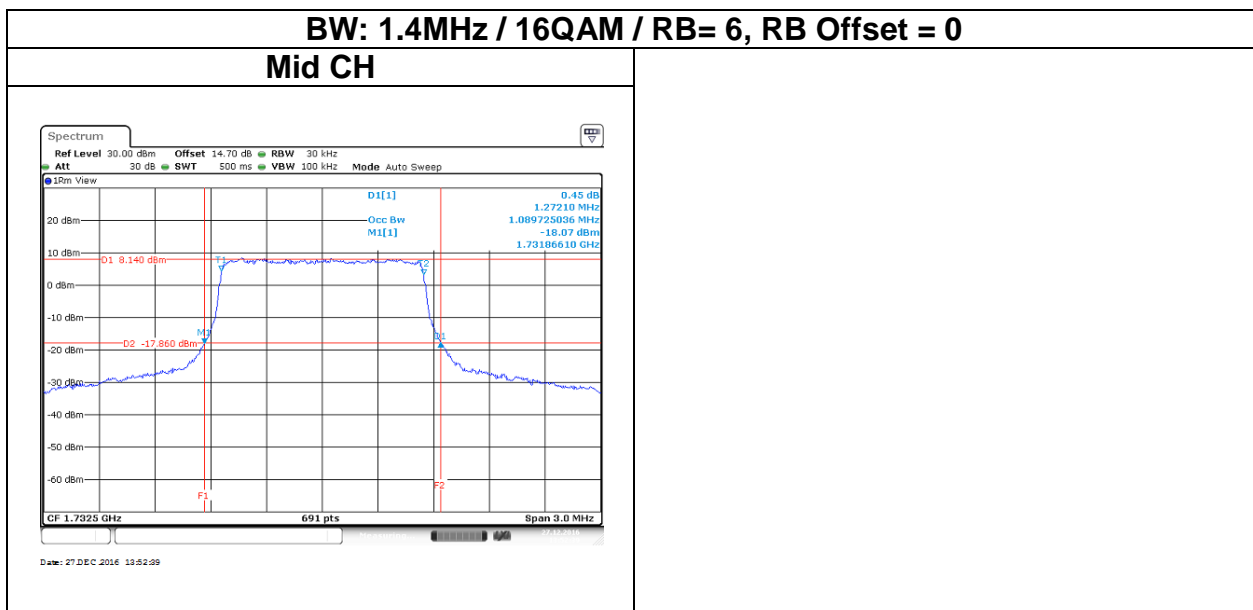
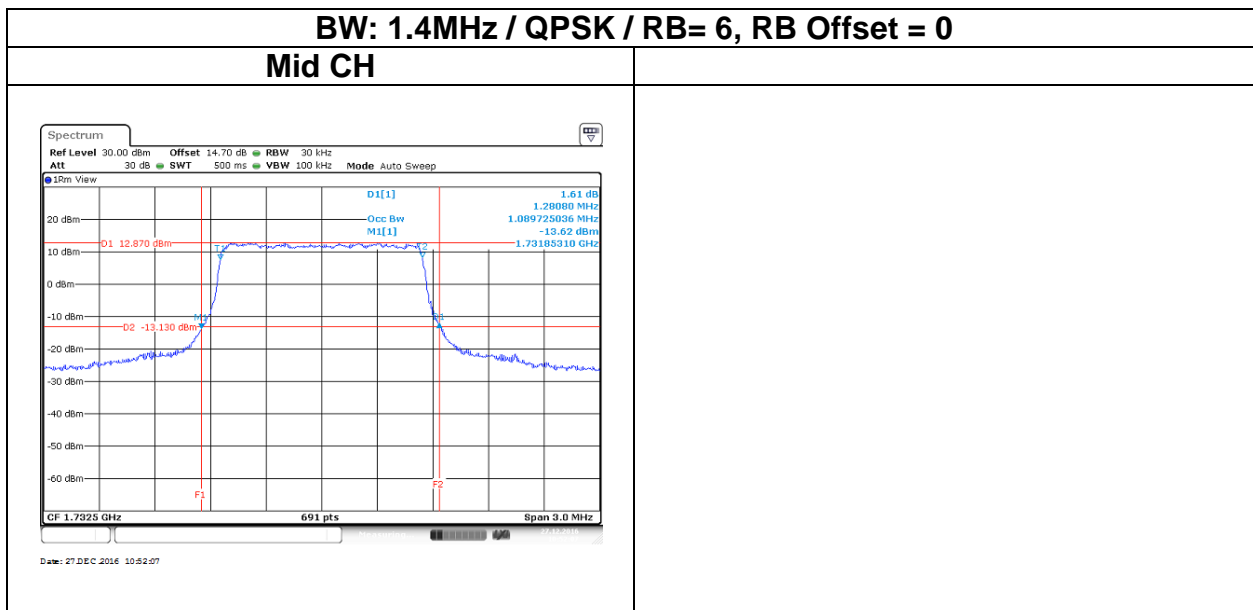

**BW: 3MHz / QPSK / RB= 15, RB Offset = 0**

**Mid CH**

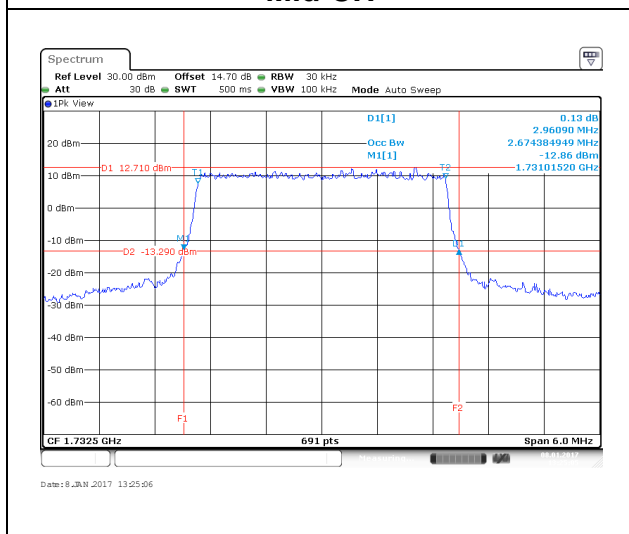

**BW: 3MHz / 16QAM / RB= 15, RB Offset = 0**

**Mid CH**

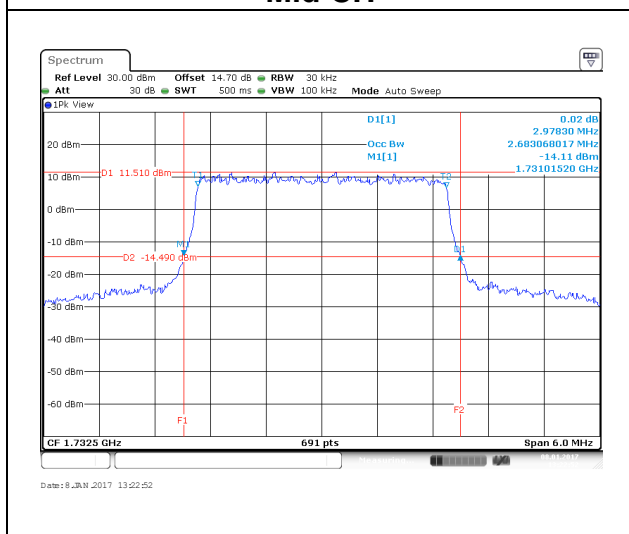

**BW: 5MHz / QPSK / RB= 25, RB Offset = 0**

**Mid CH**

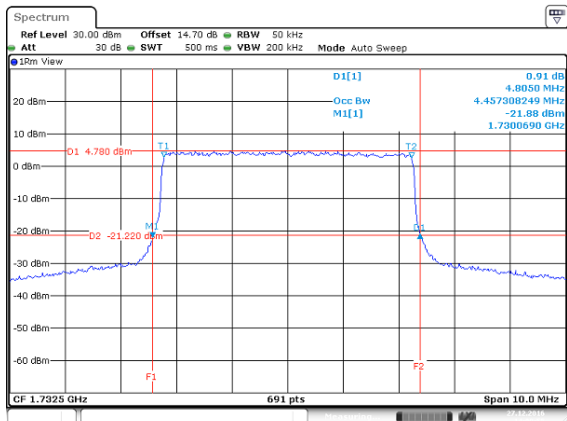

Date: 27 DEC 2016 14:00:55

**BW: 5MHz / 16QAM / RB= 25, RB Offset = 0**

**Mid CH**

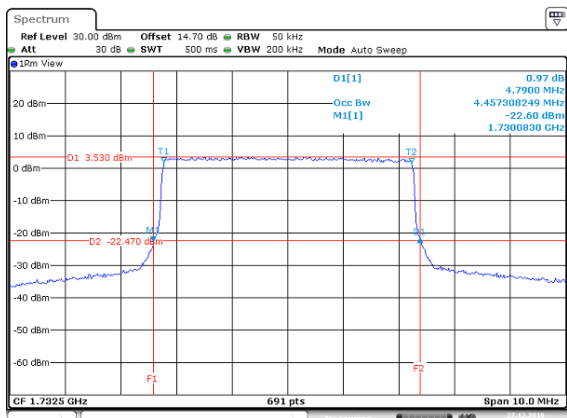

Date: 27 DEC 2016 14:03:28

**BW: 10MHz / QPSK / RB= 50, RB Offset = 0**

**Mid CH**

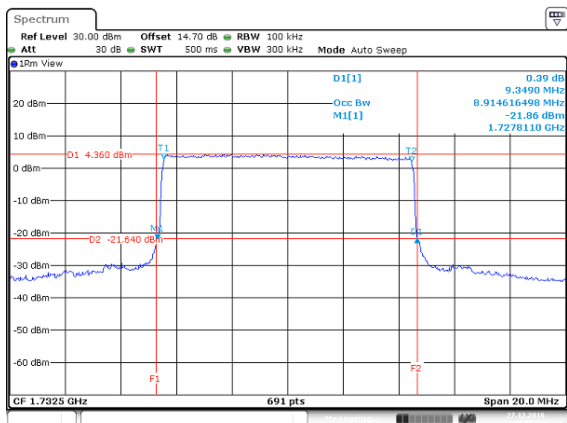

Date: 27 DEC 2016 14:20:27

**BW: 10MHz / 16QAM / RB= 50, RB Offset = 0**

**Mid CH**

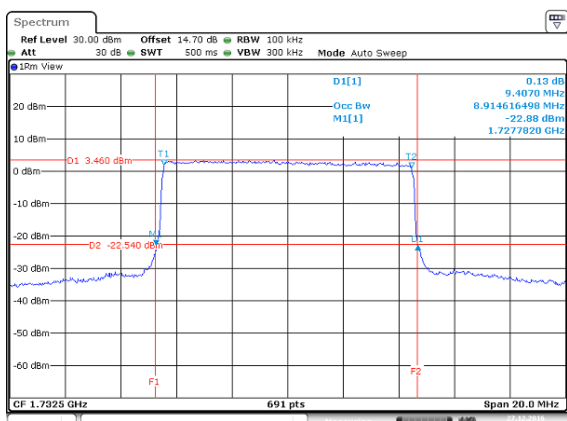

Date: 27 DEC 2016 14:18:47

**BW: 15MHz / QPSK / RB= 75, RB Offset = 0**

**Mid CH**

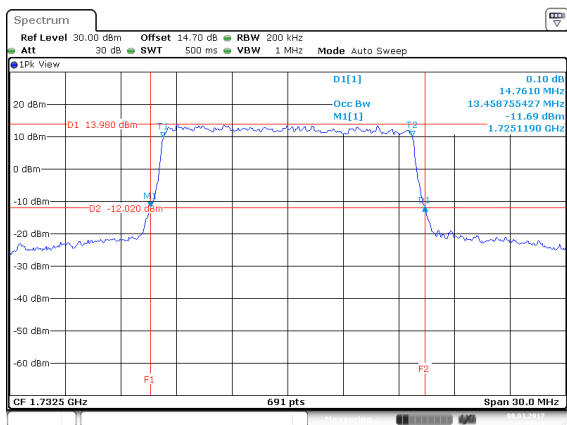

Date: 8 JUN 2017 13:27:29

**BW: 15MHz / 16QAM / RB= 75, RB Offset = 0**

**Mid CH**

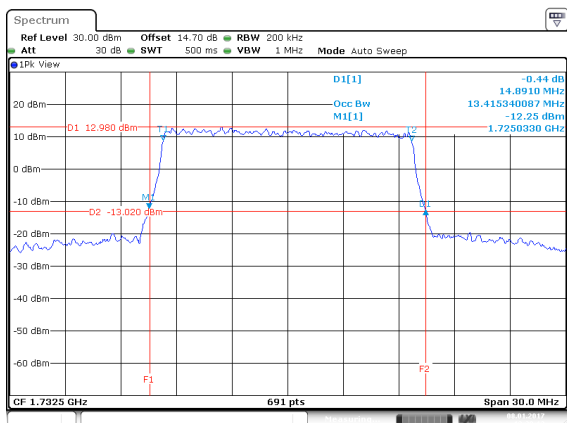

Date: 8 JUN 2017 13:30:13

**BW: 20MHz / QPSK / RB= 100, RB Offset = 0**

**Mid CH**

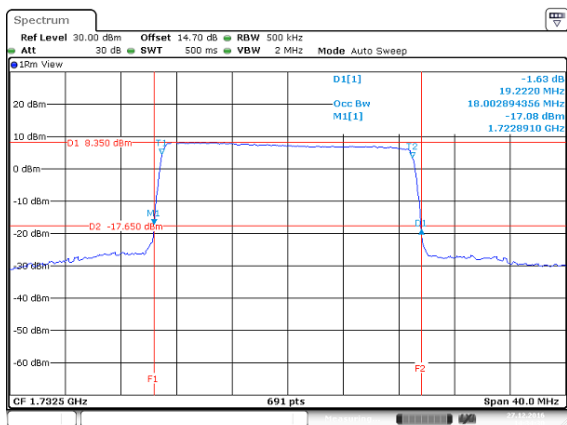

**BW: 20MHz / 16QAM / RB= 100, RB Offset = 0**

**Mid CH**

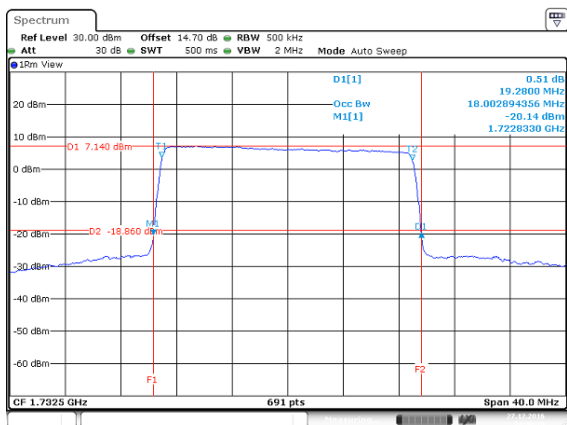

### **3.3 PEAK TO AVERAGE POWER RATIO**

#### **3.3.1 Test Limit**

In measuring transmissions in this band using an average power technique, peak-to-average power ratio (PAPR) of the transmission may not exceed 13 dB

#### **3.3.2 Test Procedure**

According to KDB 971168 D01, section. 5.7.1.

1. The EUT was connect to spectrum analyzer and call box..
2. Set the CCDF function in spectrum analyzer.
3. The highest RF output power were measured and recorded the maximum PAPR level associated with a probability of 0.1%.
4. Record the Peak to Average Power Ratio.

#### **3.3.3 Test Setup**

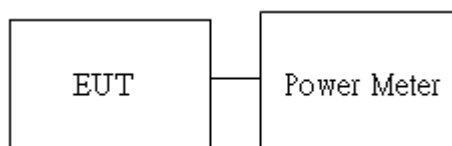

### 3.3.4 Test Result

## Test Data

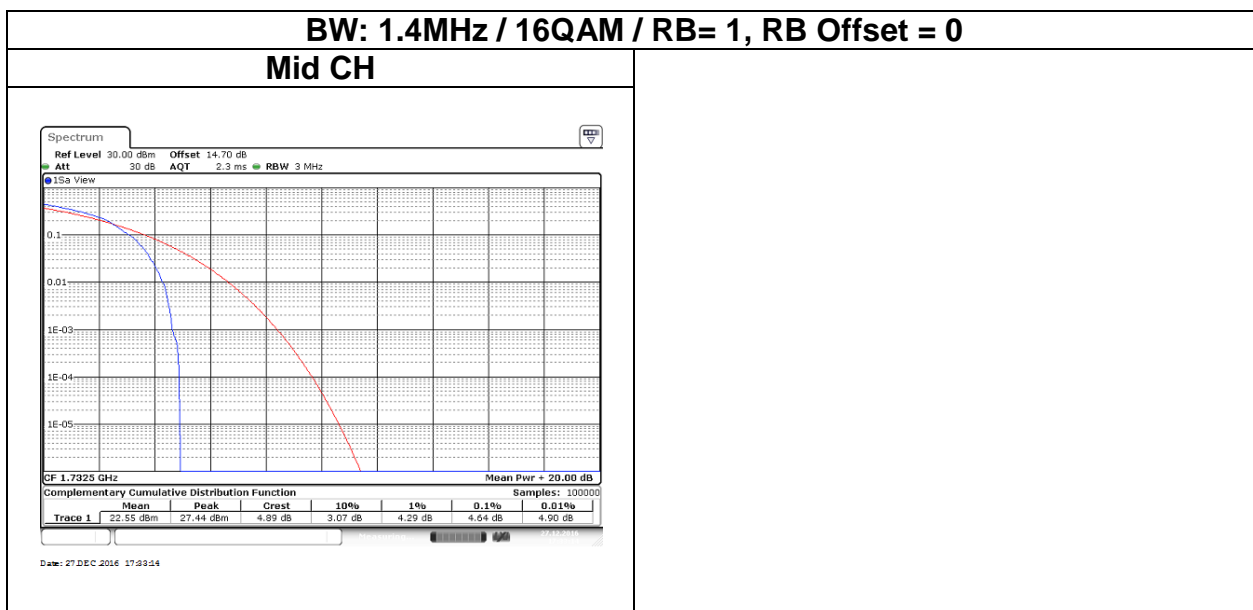
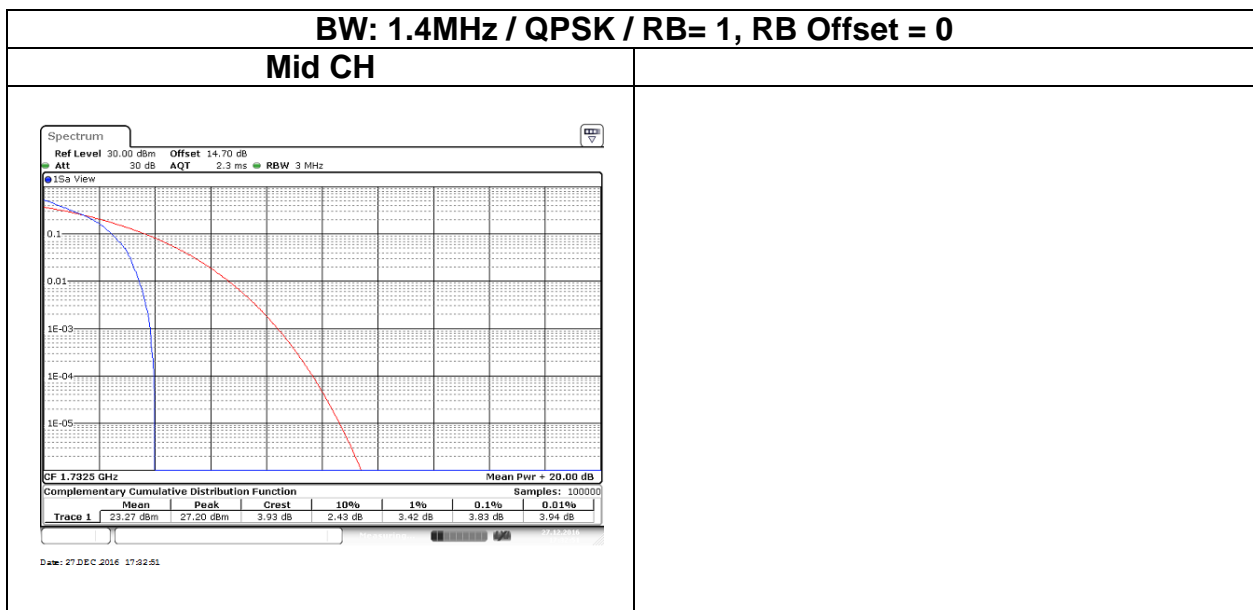



**BW: 3MHz / QPSK / RB= 1, RB Offset = 0**

**Mid CH**

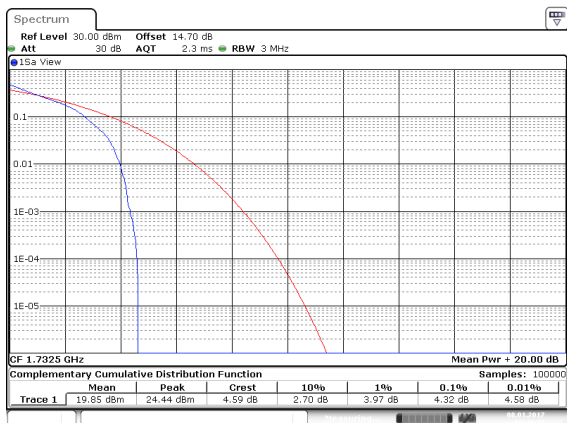

Date: 8 JUN 2017 13:40:23

**BW: 3MHz / 16QAM / RB= 1, RB Offset = 0**

**Mid CH**

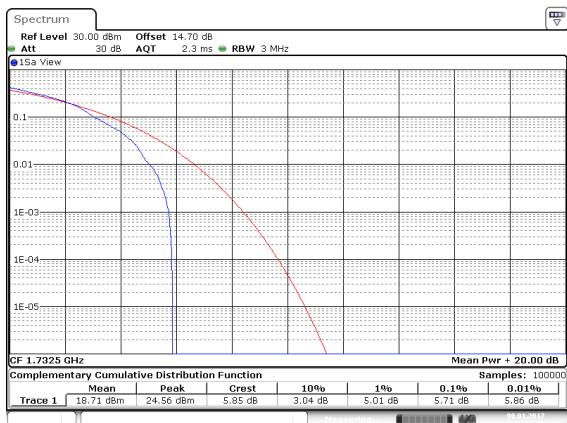

Date: 8 JUN 2017 13:41:58

**BW: 5MHz / QPSK / RB= 1, RB Offset = 0**

**Mid CH**

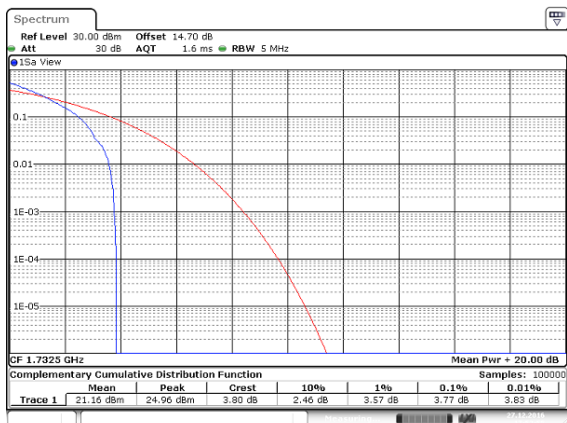

Date: 27 DEC 2016 17:52:55

**BW: 5MHz / 16QAM / RB= 1, RB Offset = 0**

**Mid CH**

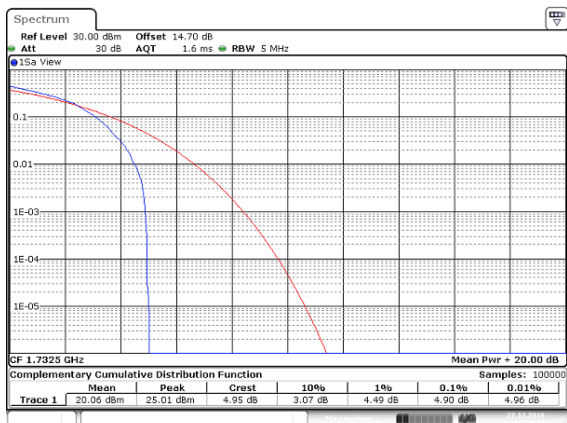

Date: 27 DEC 2016 17:54:16

**BW: 10MHz / QPSK / RB= 1, RB Offset = 0**

**Mid CH**

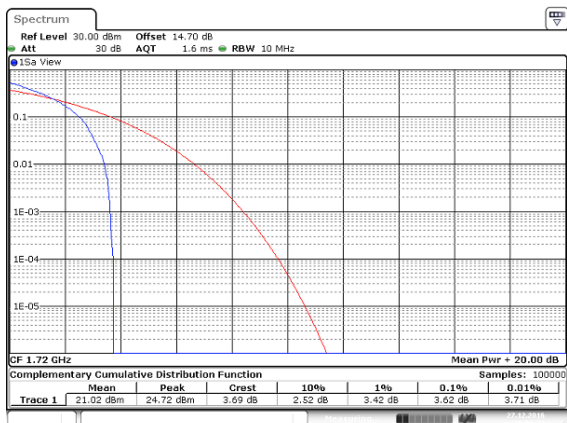

Date: 27 DEC 2016 15:01:23

**BW: 10MHz / 16QAM / RB= 1, RB Offset = 0**

**Mid CH**

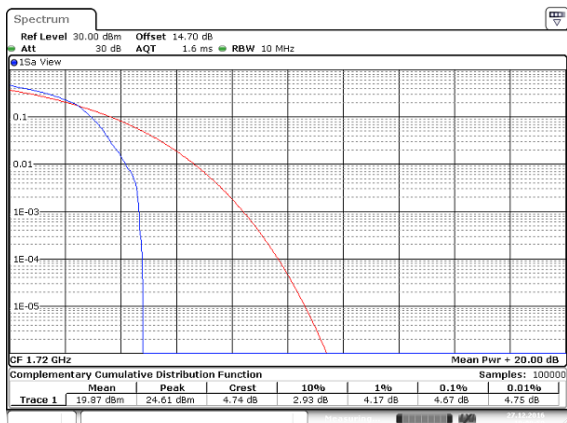

Date: 27 DEC 2016 15:00:58

**BW: 15MHz / QPSK / RB= 1, RB Offset = 0**

**Mid CH**

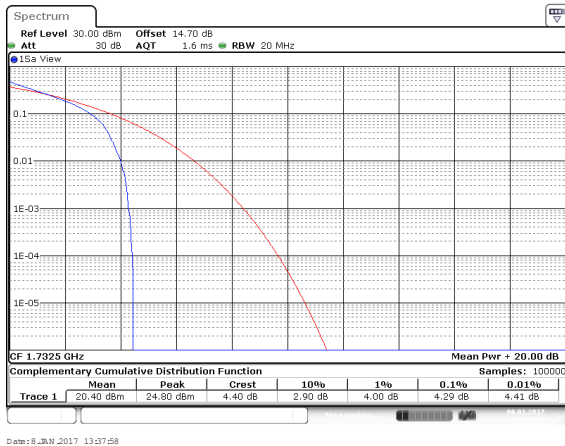

**BW: 15MHz / 16QAM / RB= 1, RB Offset = 0**

**Mid CH**

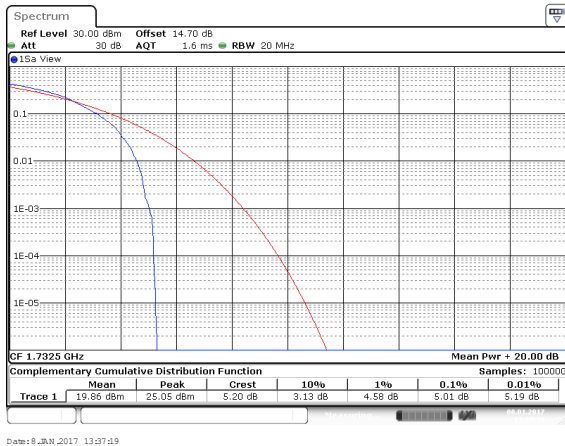

**BW: 20MHz / QPSK / RB= 1, RB Offset = 0**

**Mid CH**

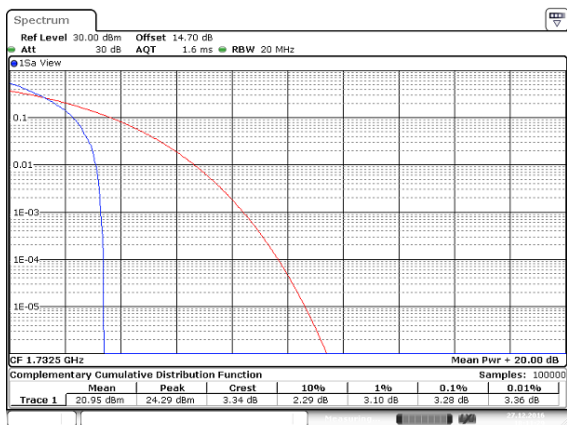

Date: 27 DEC 2016 18:11:29

**BW: 20MHz / 16QAM / RB= 1, RB Offset = 0**

**Mid CH**

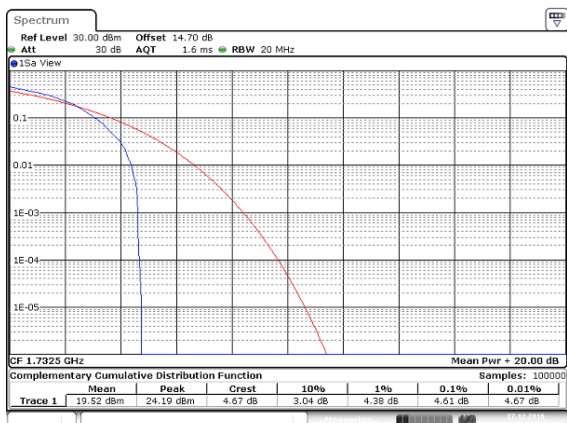

Date: 27 DEC 2016 18:11:57

## 3.4 BANDEDGE MEASUREMENT

### 3.4.1 Test Limit

#### FCC §27.53(h), Band 4

For operations in the, 1710-1755 MHz band, the power of any emission outside a licensee's frequency block shall be attenuated below the transmitter power (P) in watts by at least  $43 + 10 \log_{10} (P)$  dB.

### 3.4.2 Test Procedure

KDB 971168 D01 v02r02 - Section 6.0

1. RBW  $\geq$  1% of the emission bandwidth.
2. VBW  $\geq$  3 x RBW
3. Span was set large enough so as to capture all out of emissions near the band edge.

### 3.4.3 Test Setup

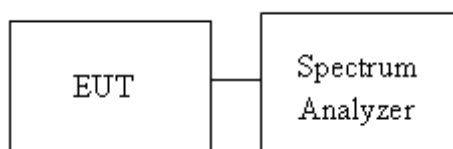

### 3.4.4 Test Result

### Test Data

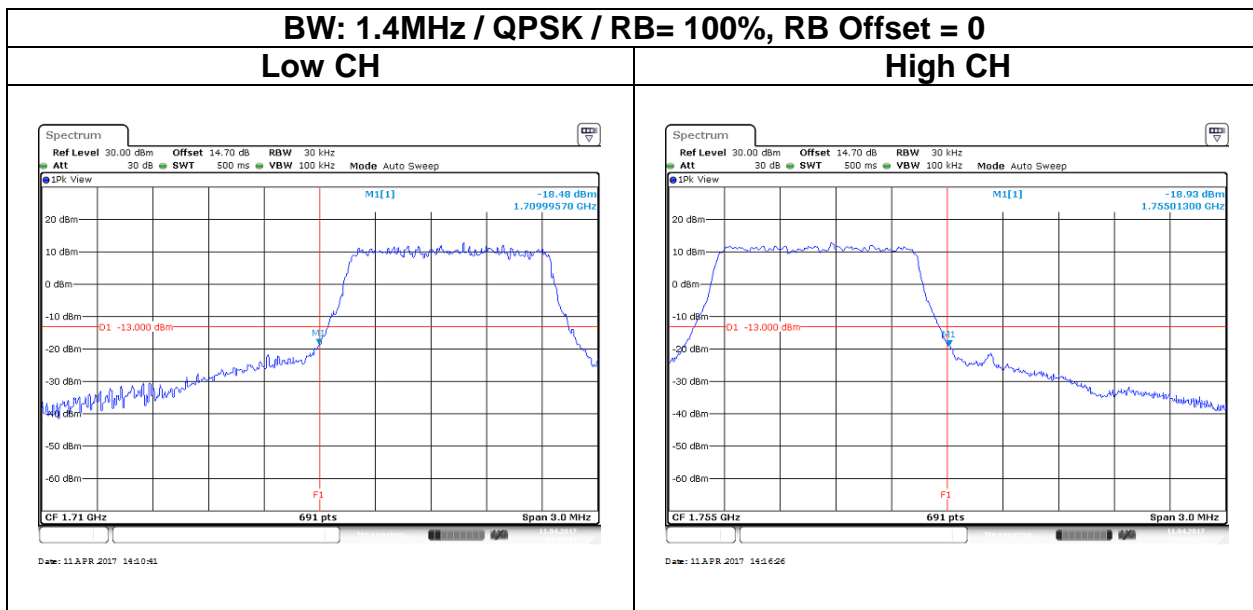
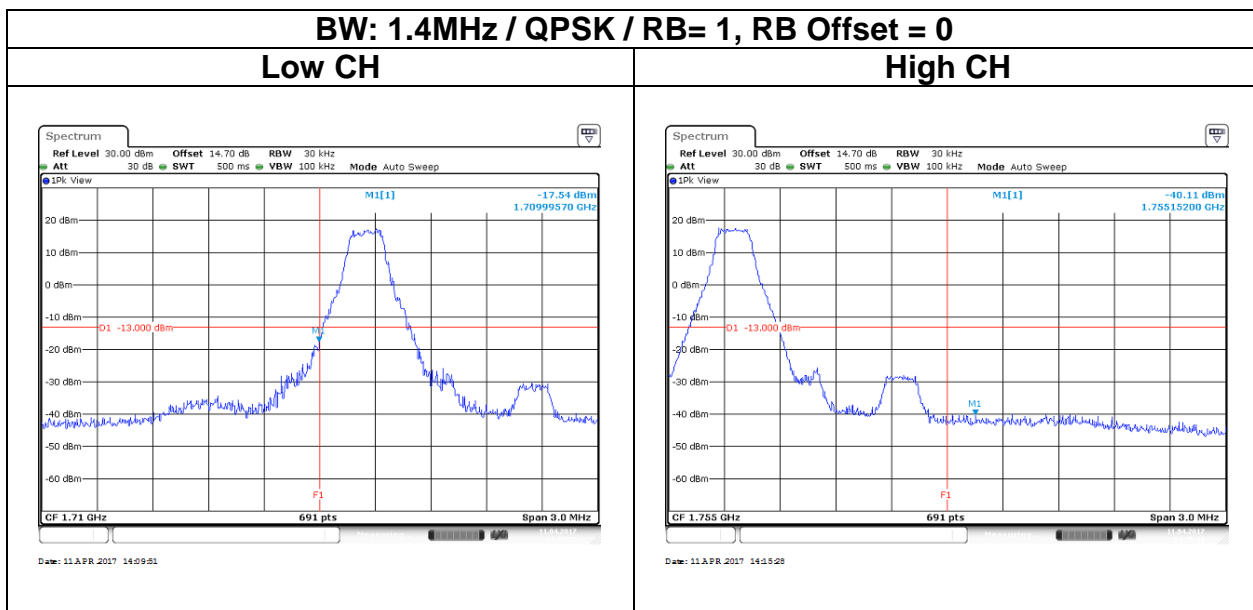

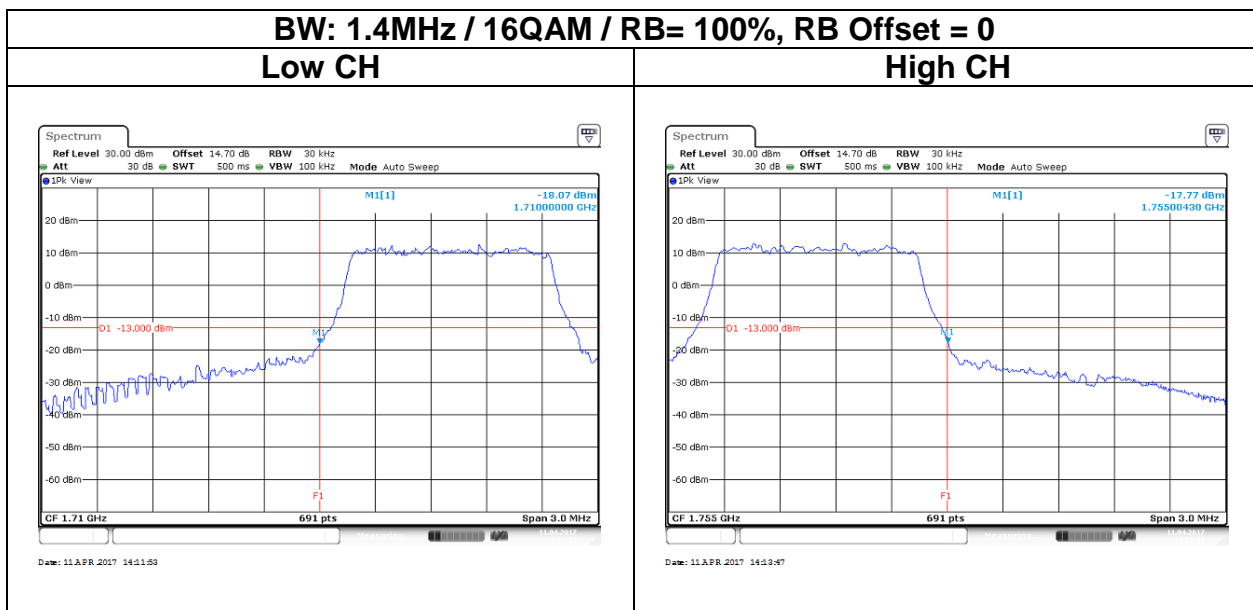
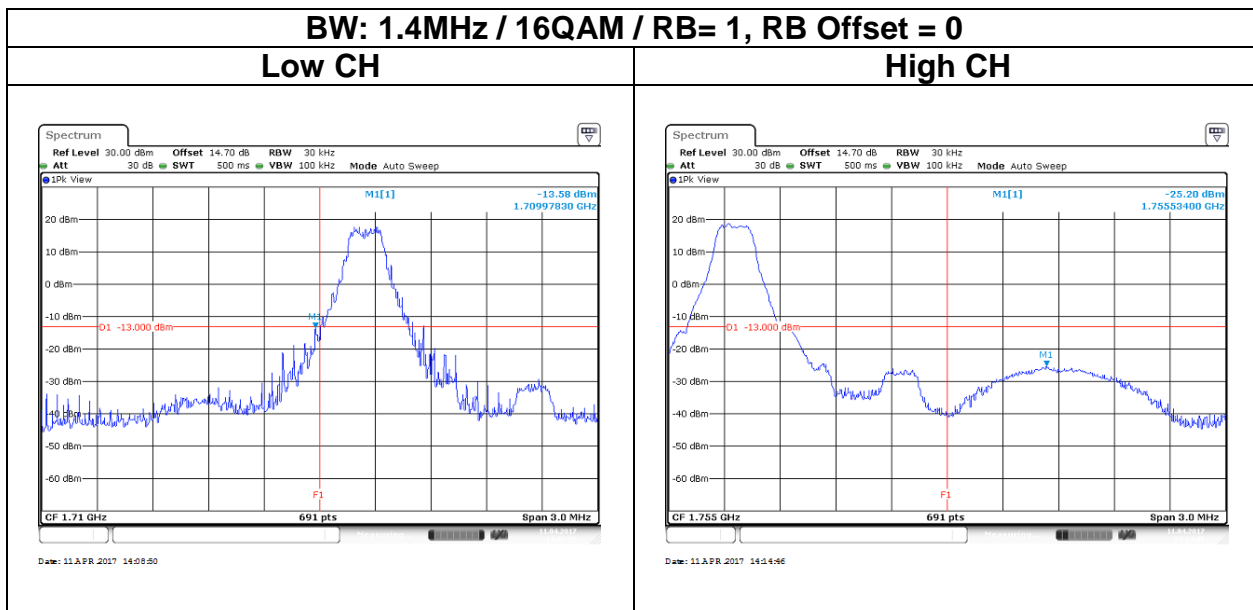



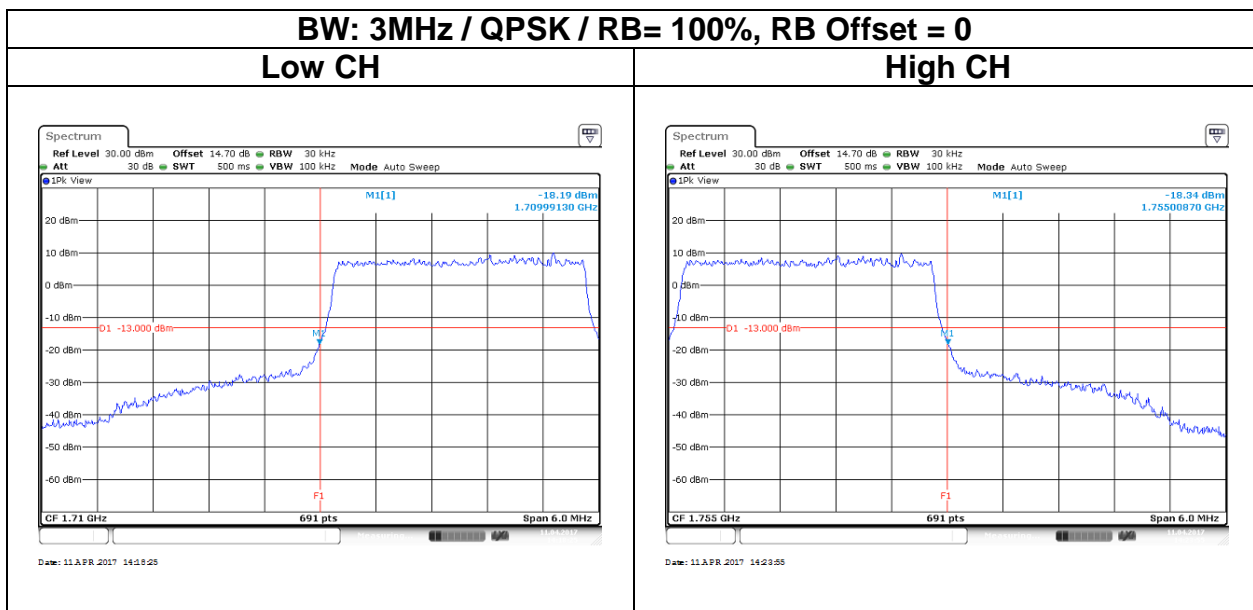
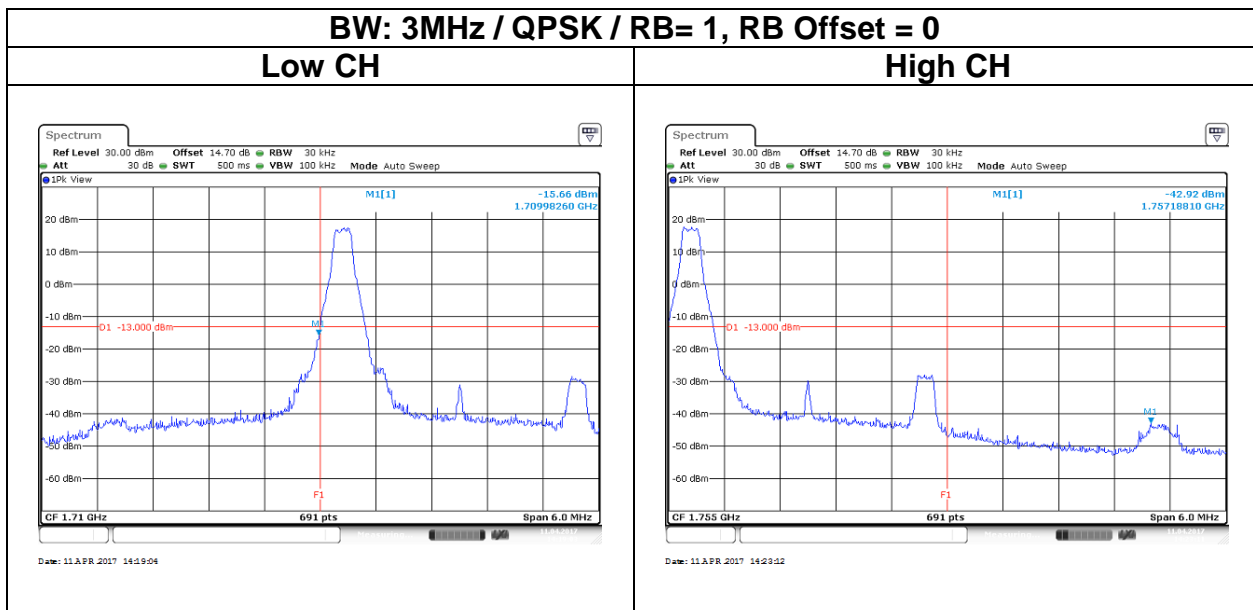

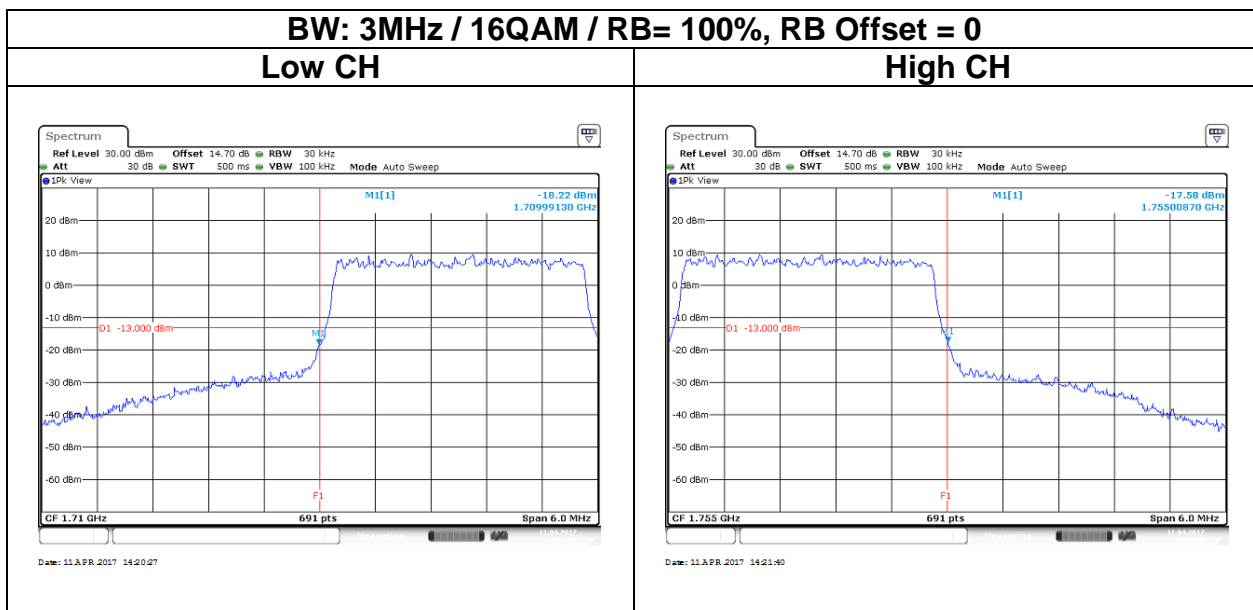
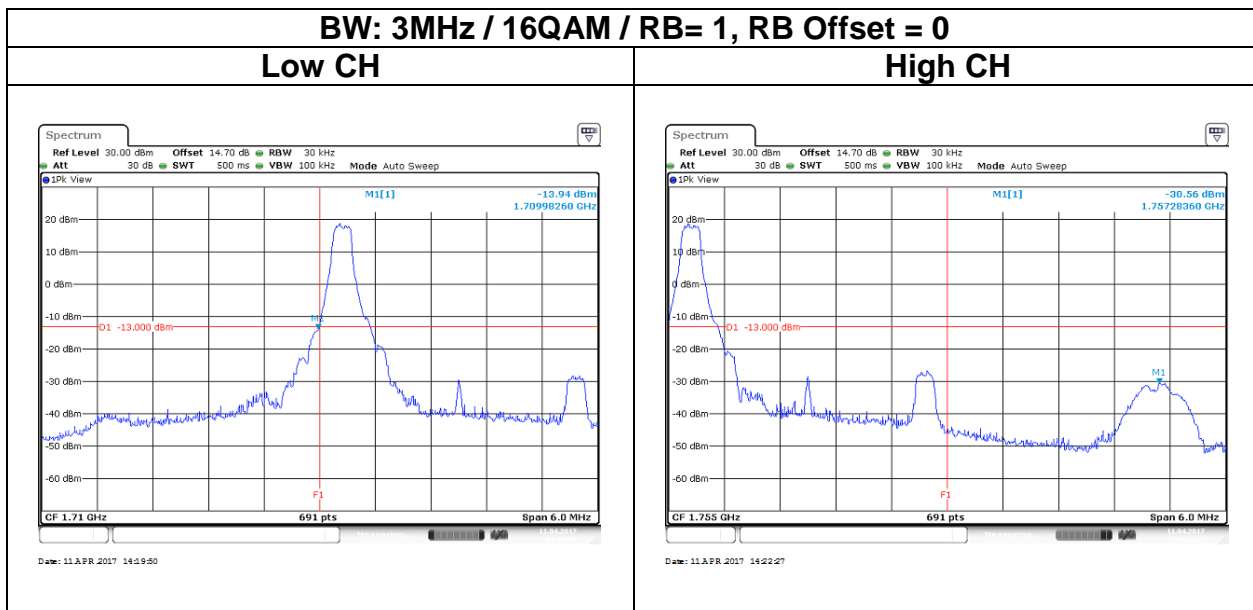

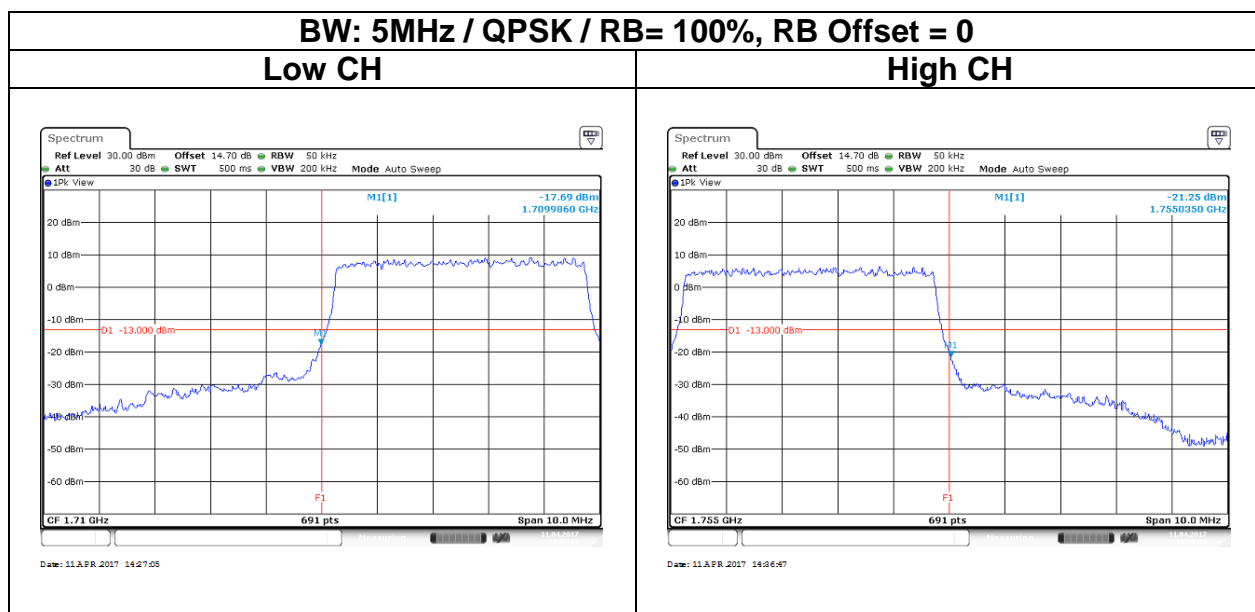
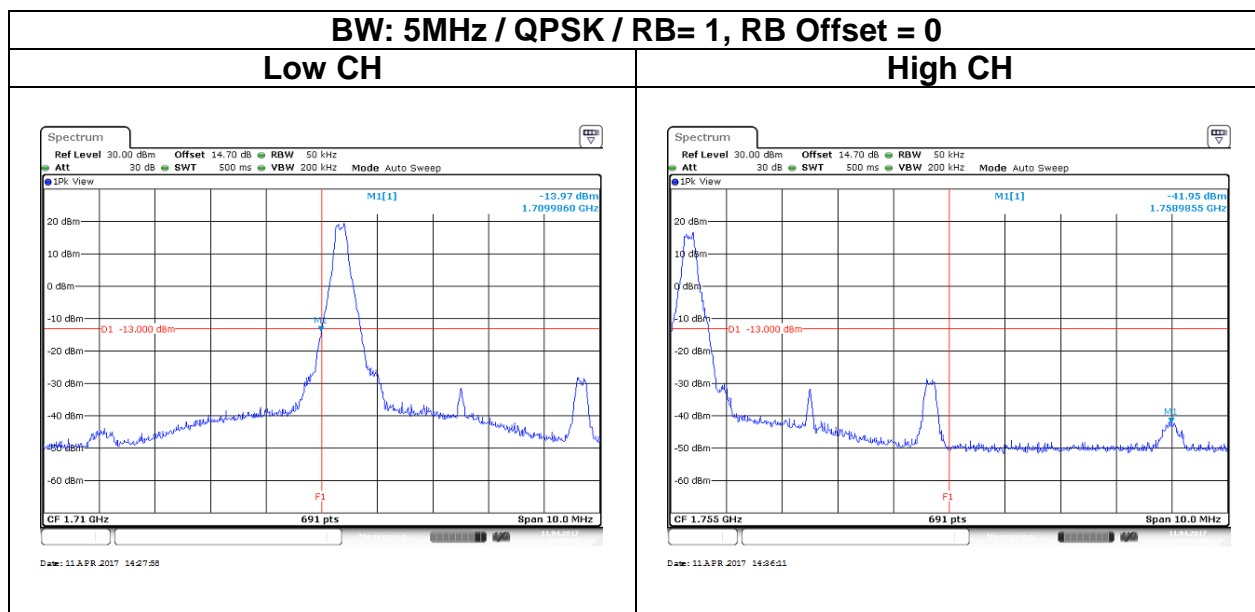

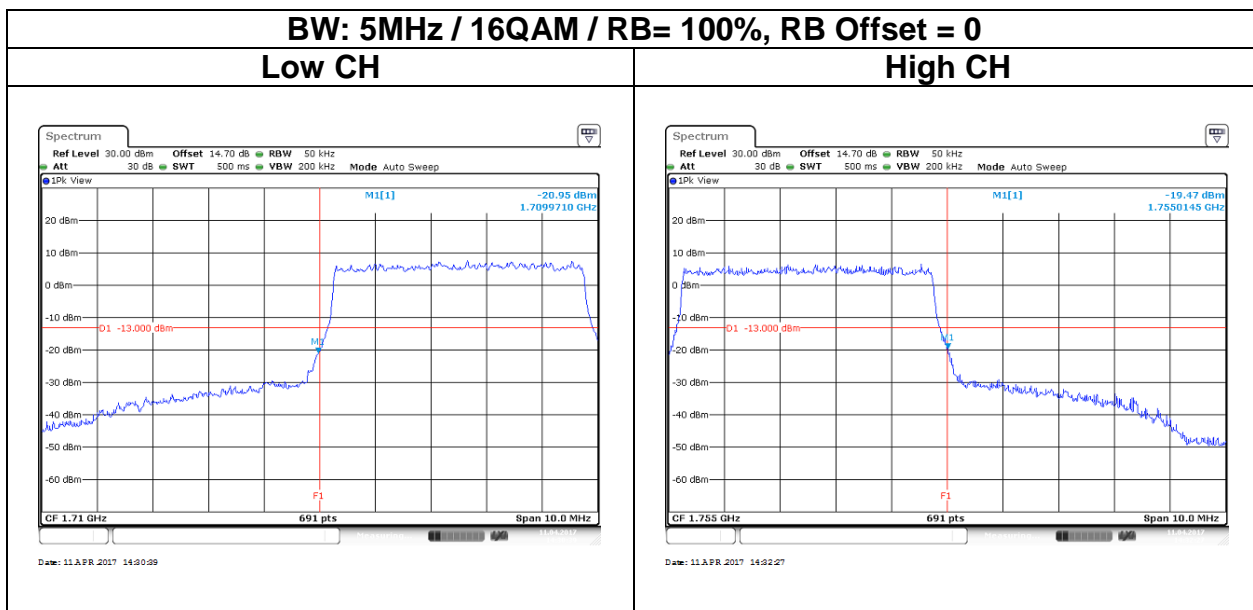
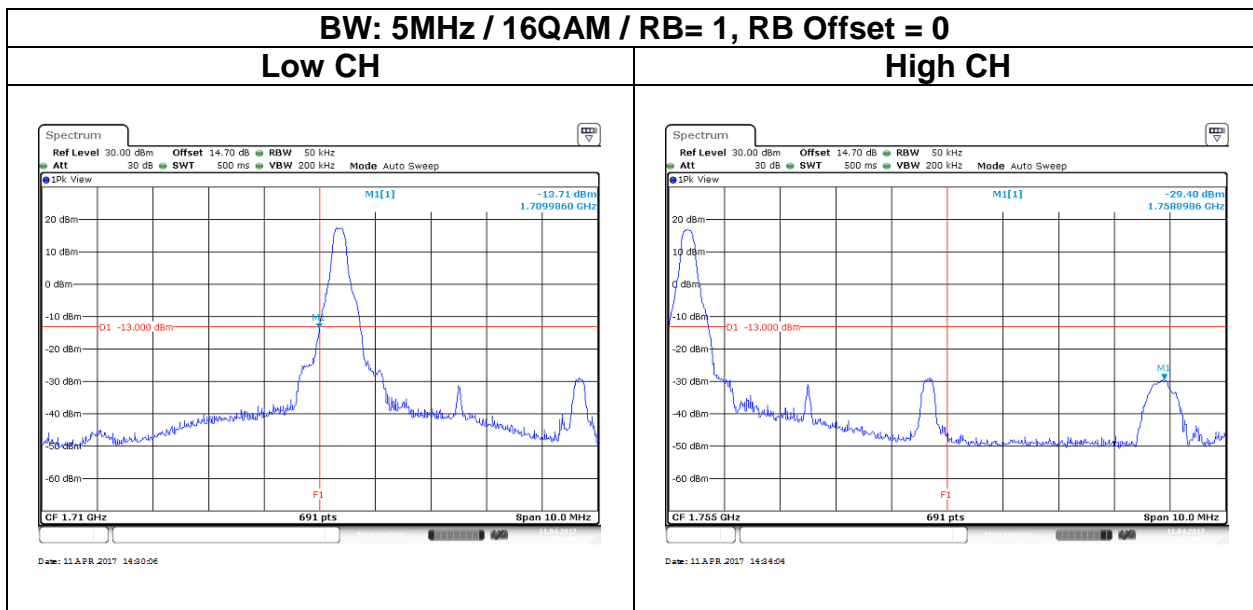

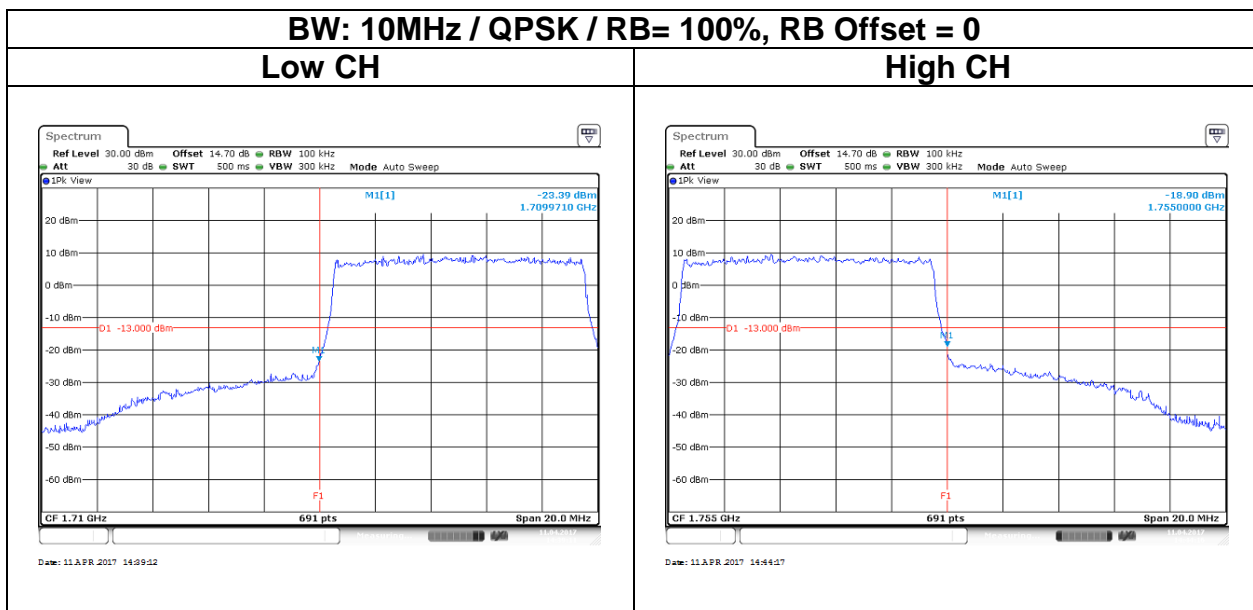
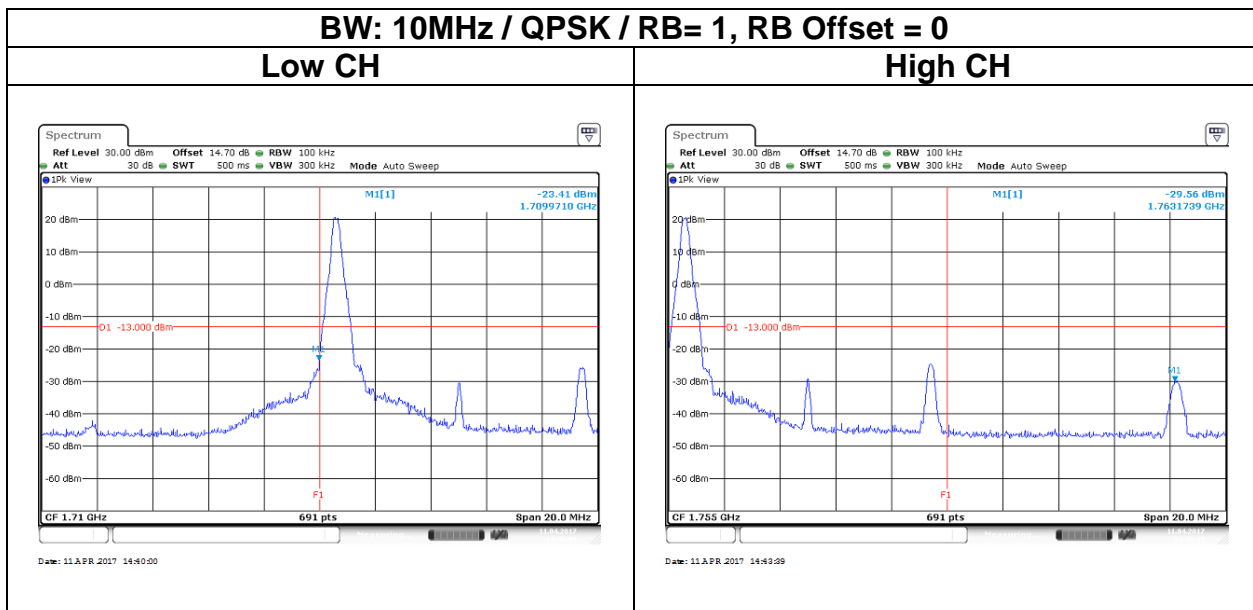

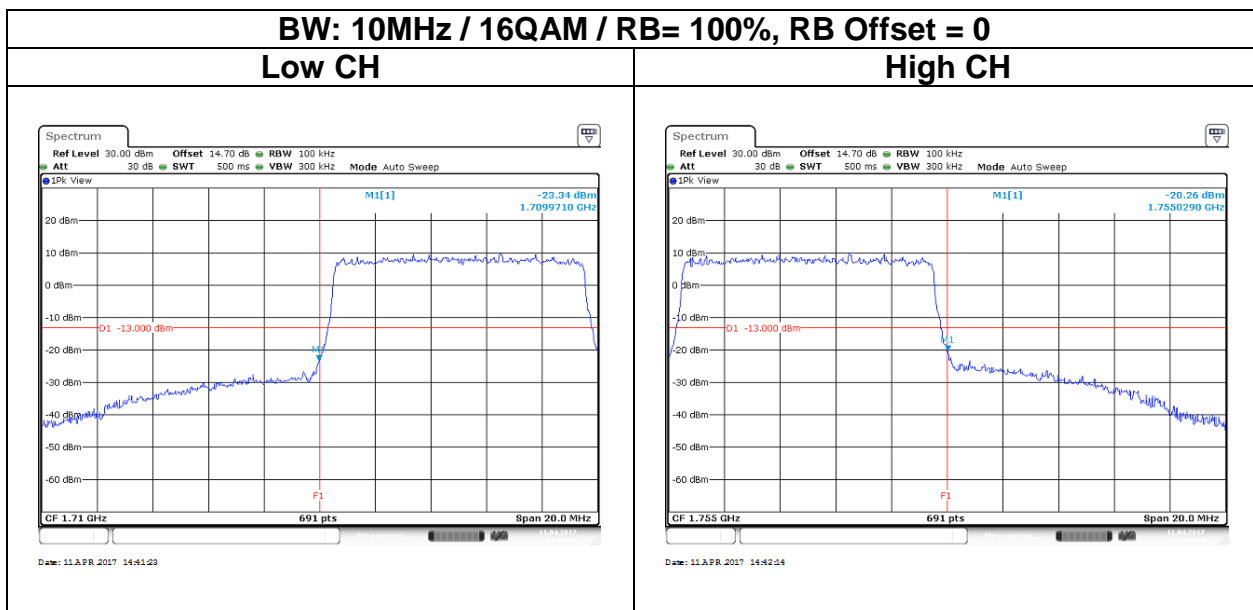
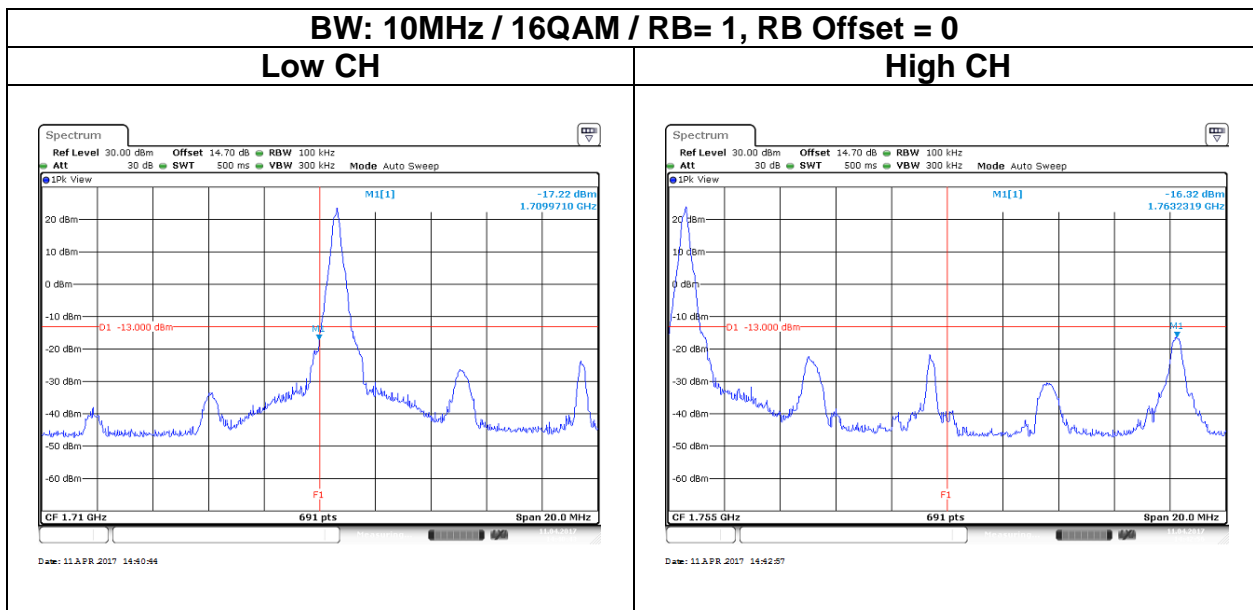

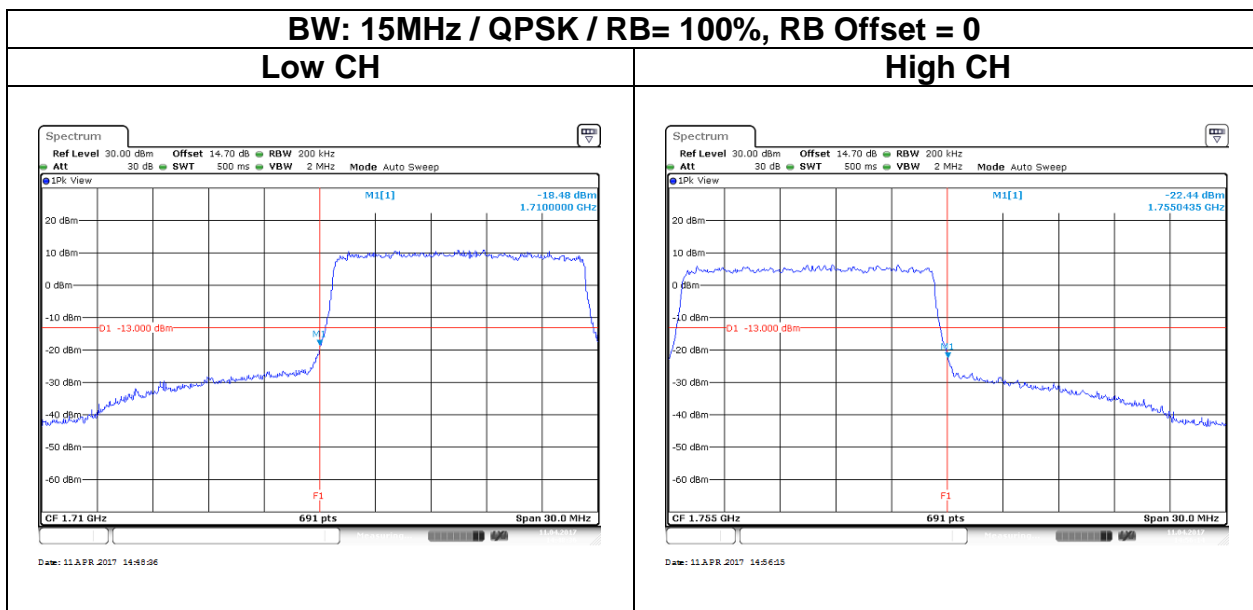
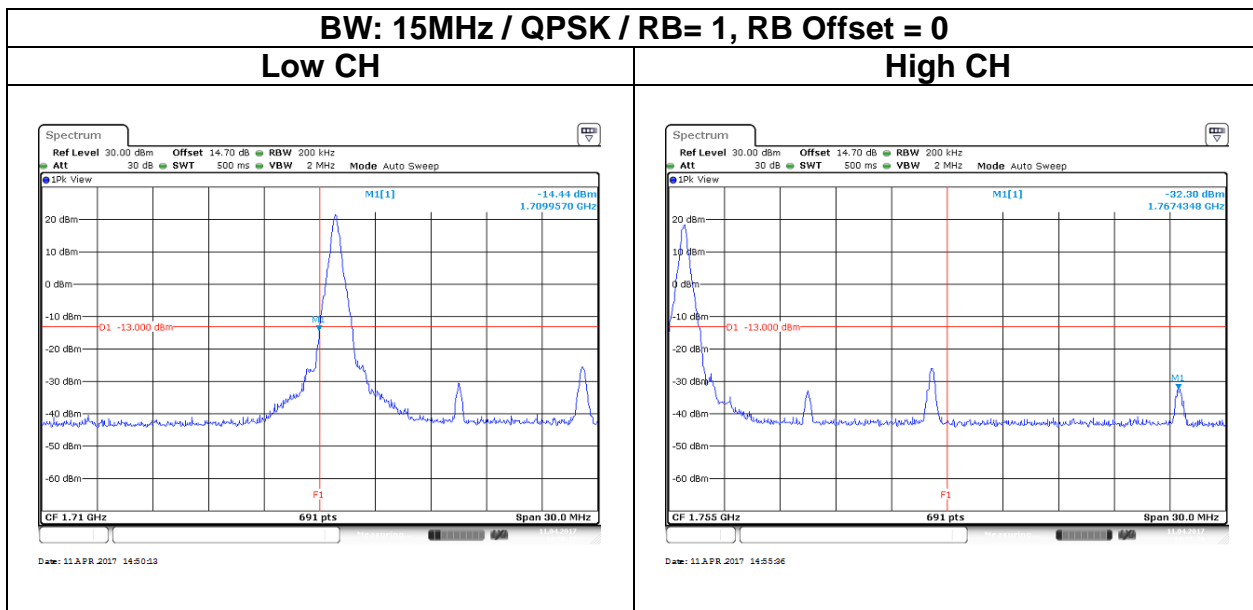

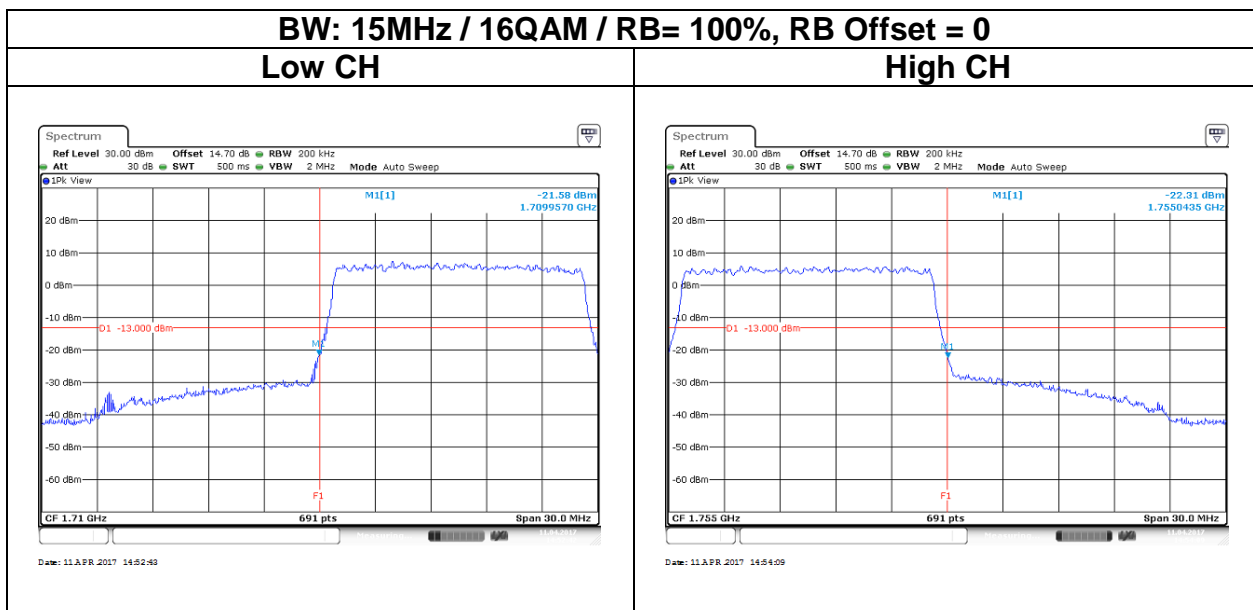
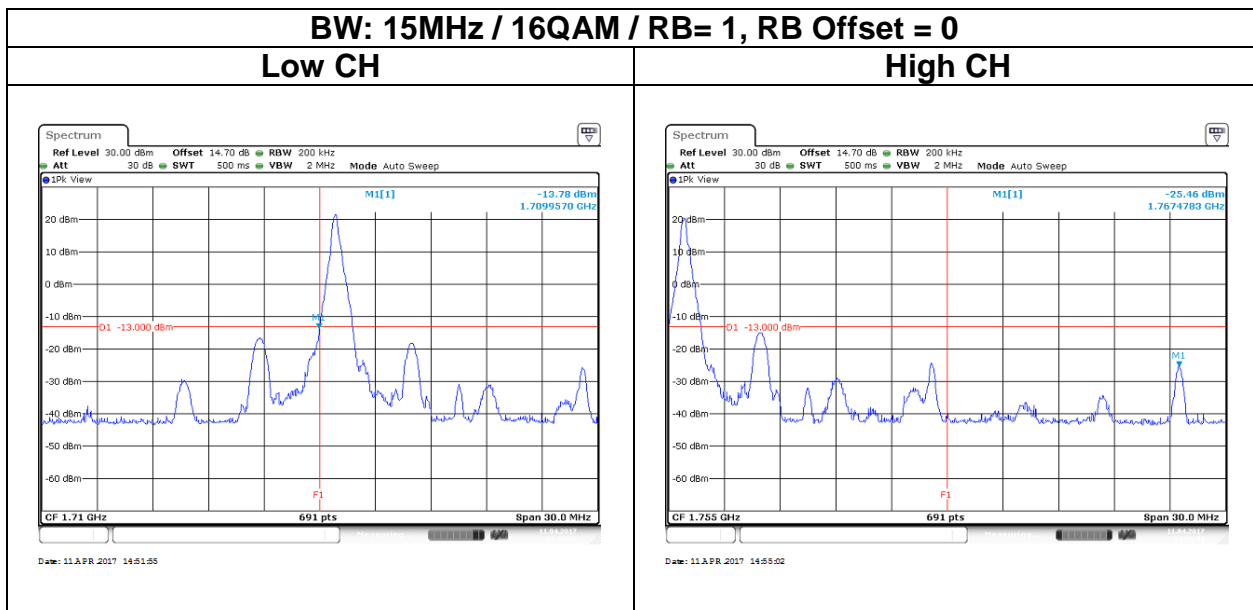



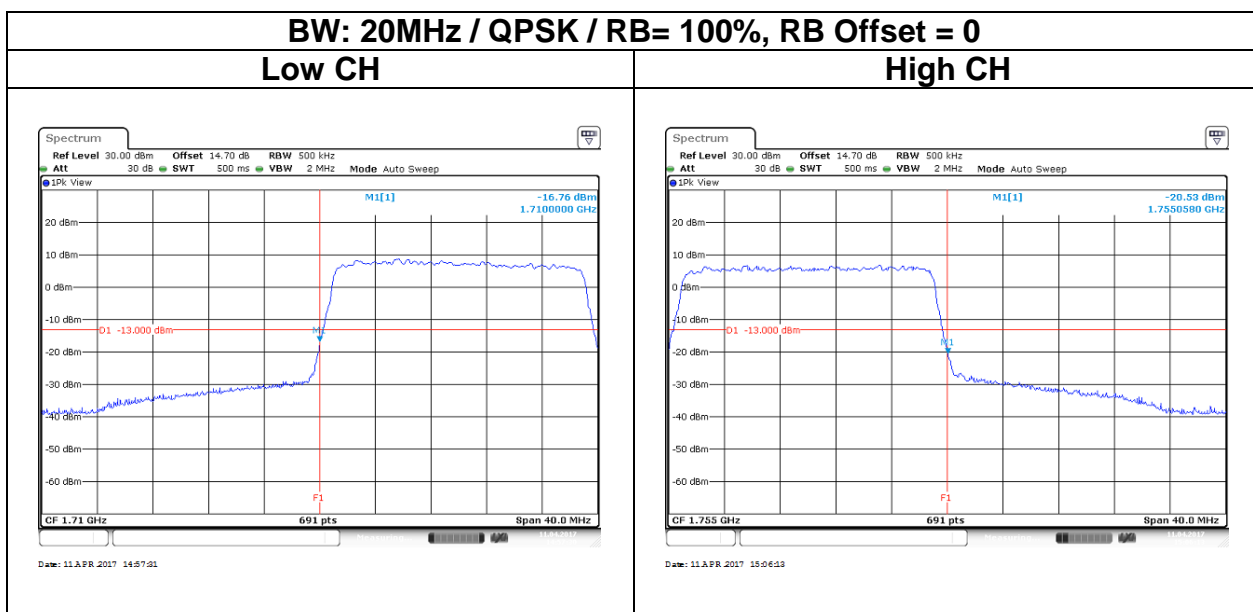
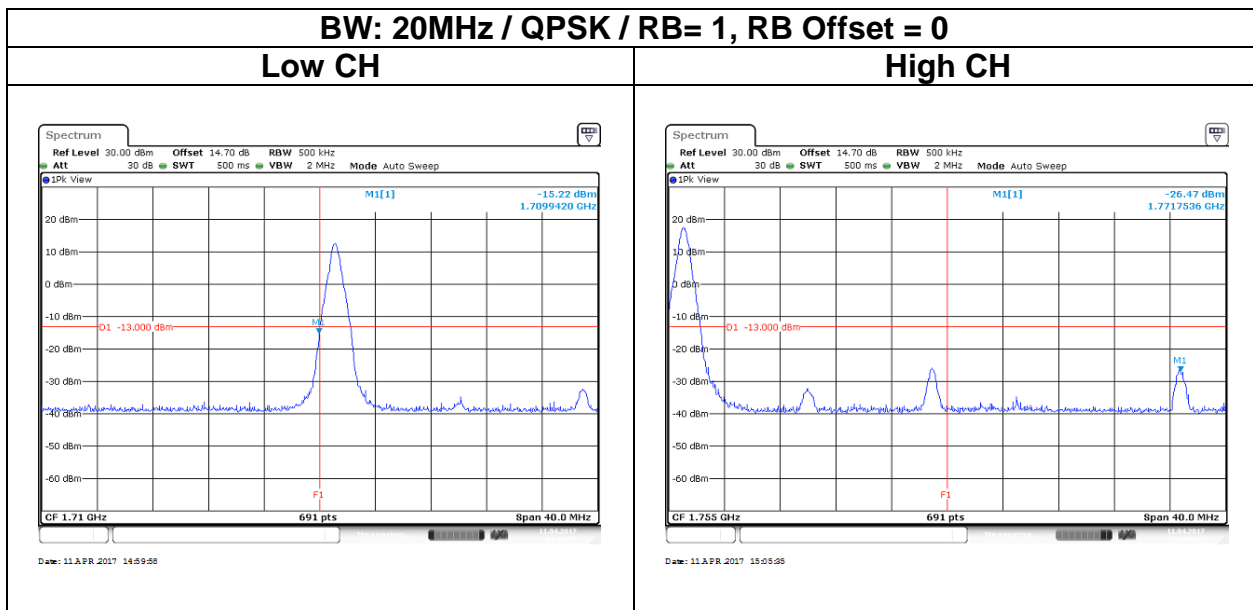

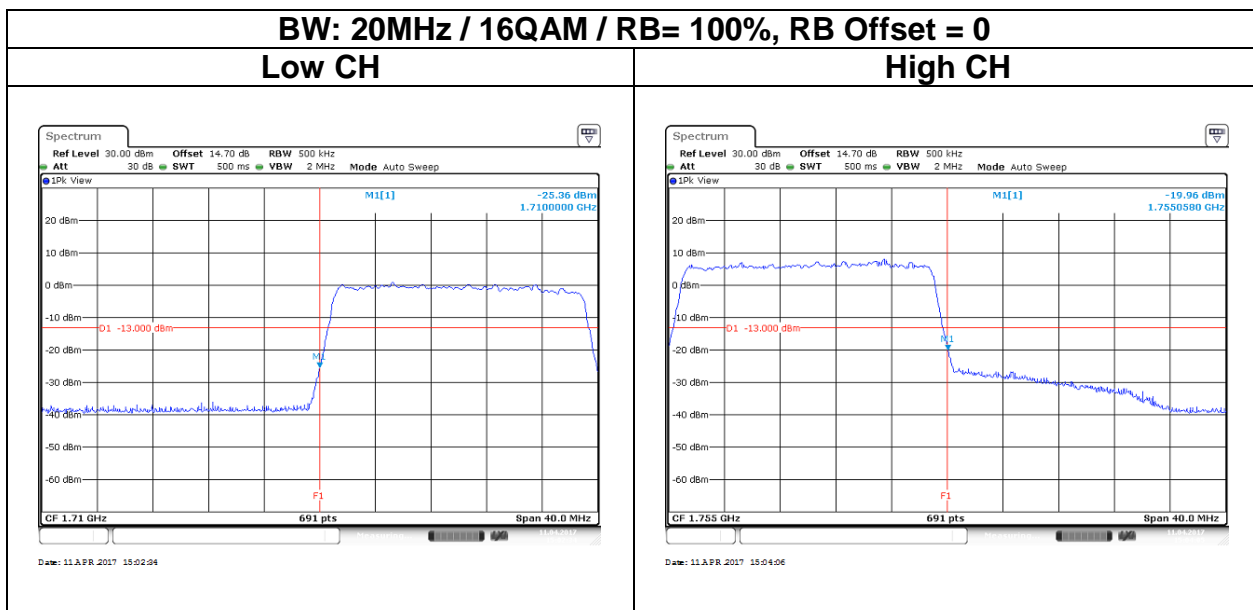
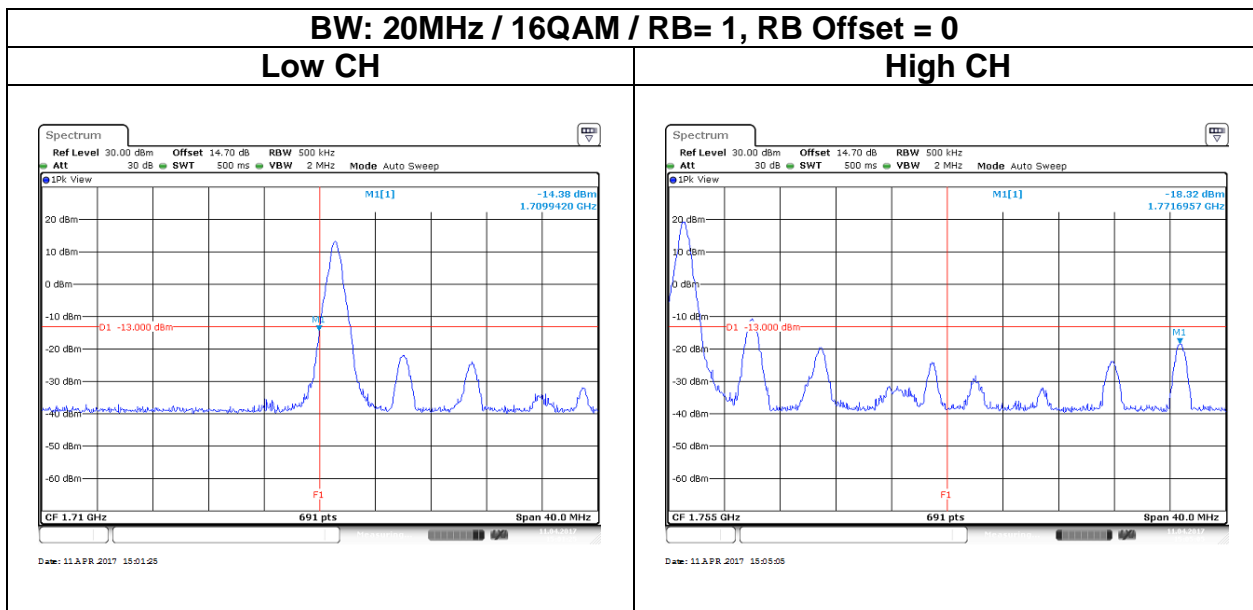

## **3.5 CONDUCTED SPURIOUS EMISSION**

### **3.5.1 Test Limit**

The power of any emission outside a licensee's frequency block shall be attenuated below the transmitter power (P) by at least  $43 + 10 \log_{10}(P)$  dB. The limit of emission equal to  $-13\text{dBm}$

### **3.5.2 Test Procedure**

1. According to KDB 971168 D01, section 6.0
2. The EUT was connect to spectrum analyzer and call box.
3. The RF output of EUT was connected to the spectrum analyzer.
4. Set the spectrum analyzer , RBW=1MHz, VBW=3MHz.
5. Record the maximum spurious emission.

The fundamental frequency should be excluded against the limit in operating band

### 3.5.3 Test Result

## Test Data

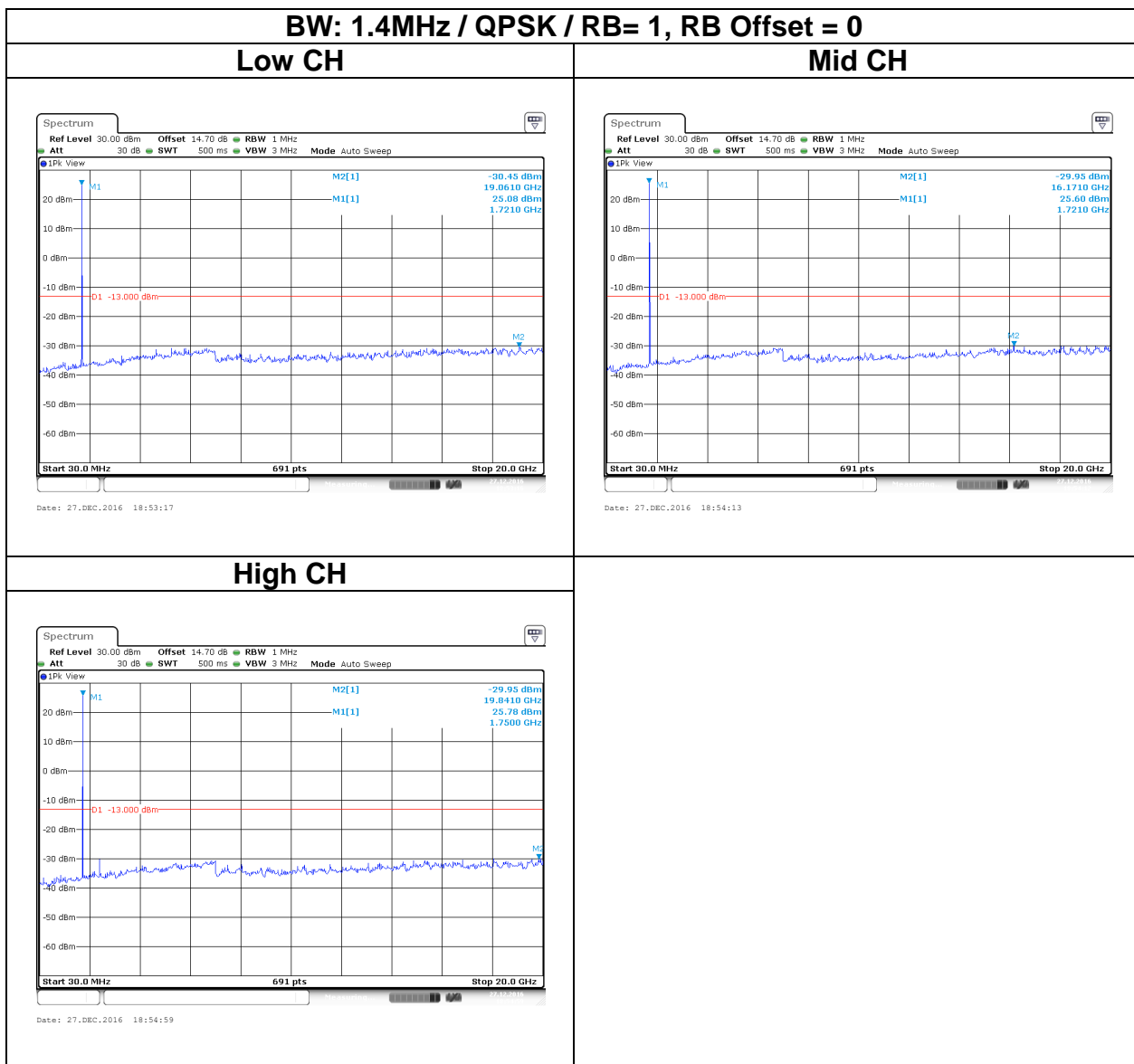

**BW: 1.4MHz / 16QAM / RB= 1, RB Offset = 0**

**Low CH**

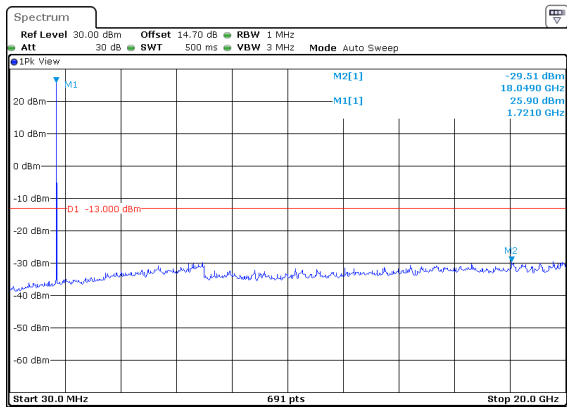

Date: 27.DEC.2016 18:37:35

**Mid CH**

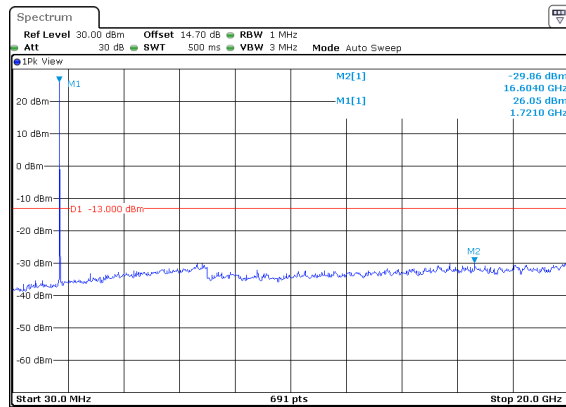

Date: 27.DEC.2016 18:36:10

**High CH**

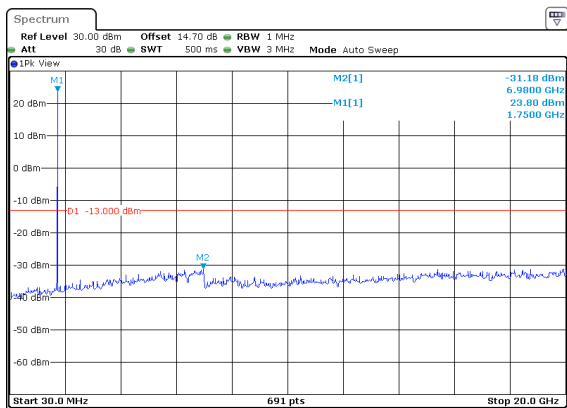

Date: 27.DEC.2016 18:35:22

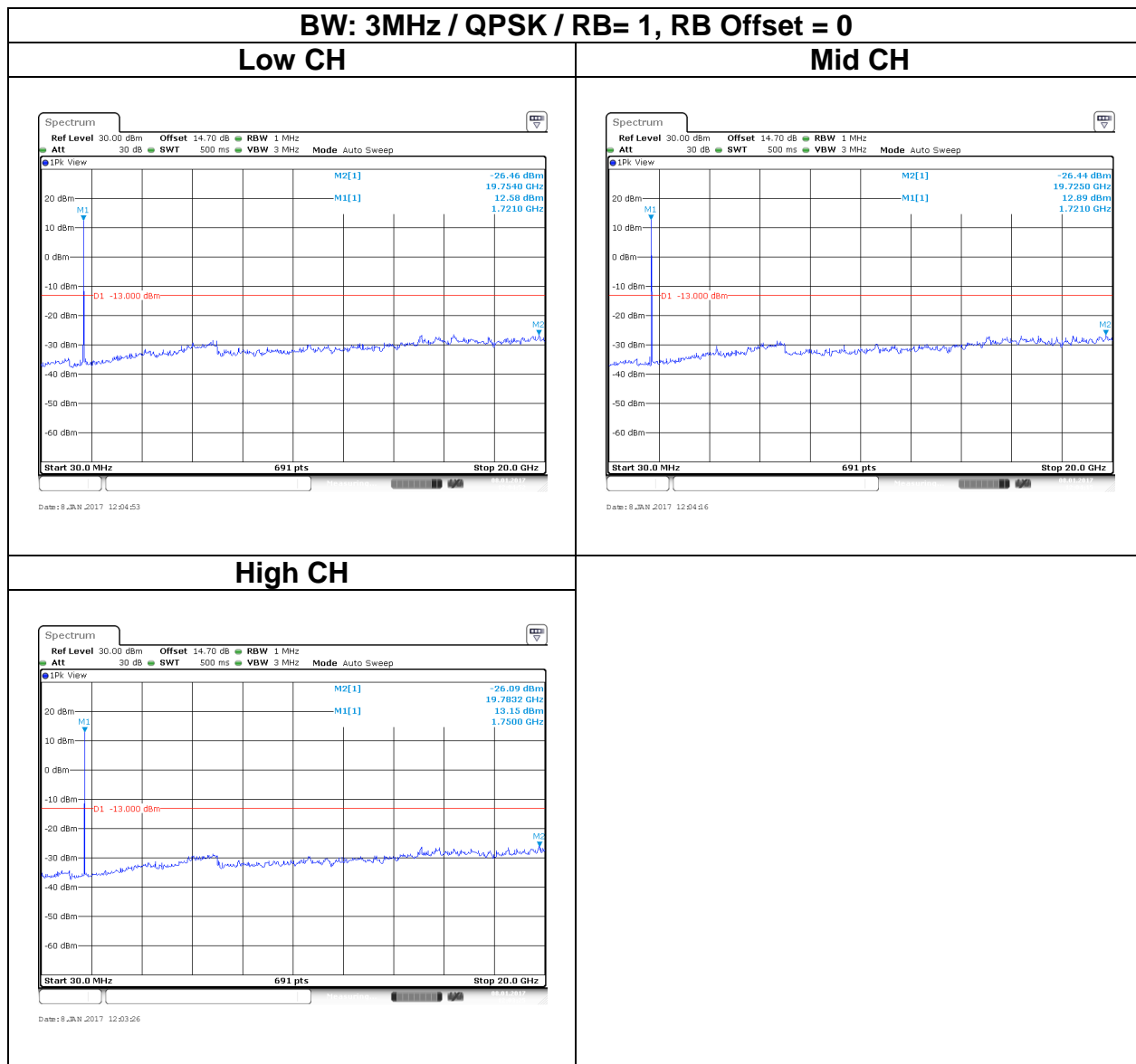

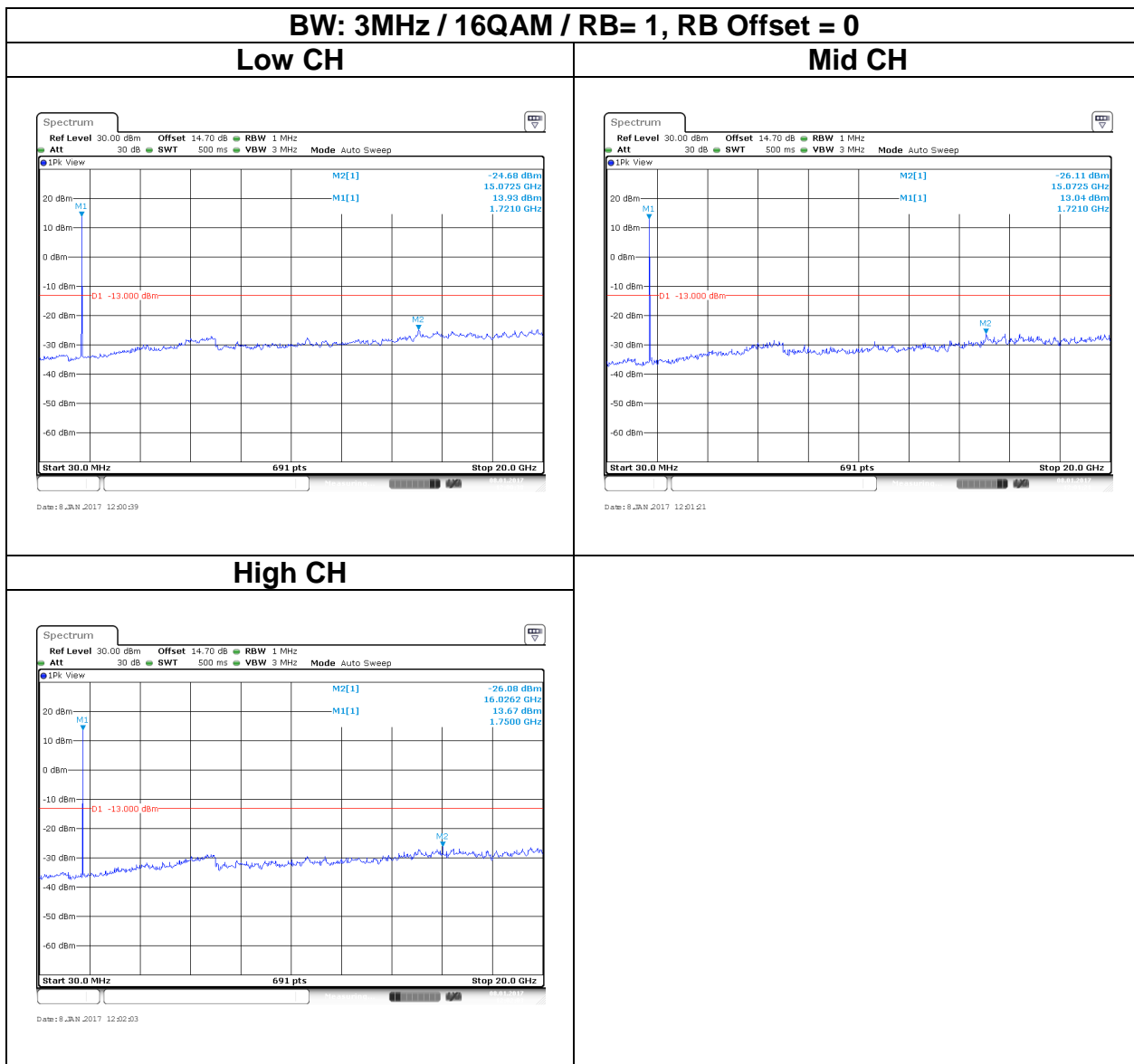

**BW: 5MHz / QPSK / RB= 1, RB Offset = 0**

**Low CH**

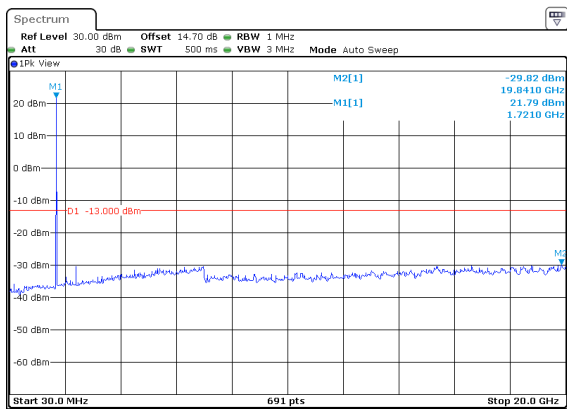

**Mid CH**

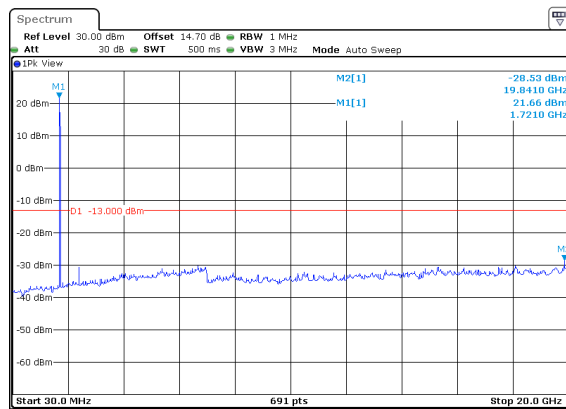

**High CH**

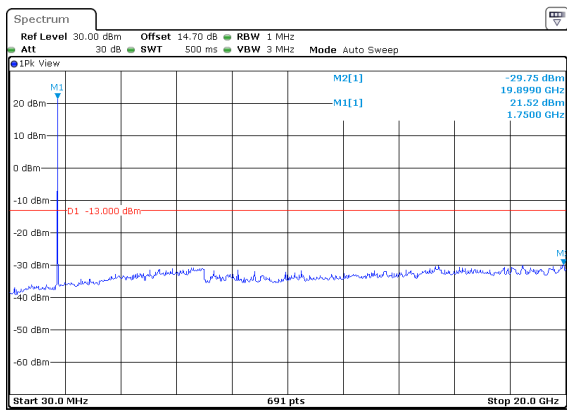



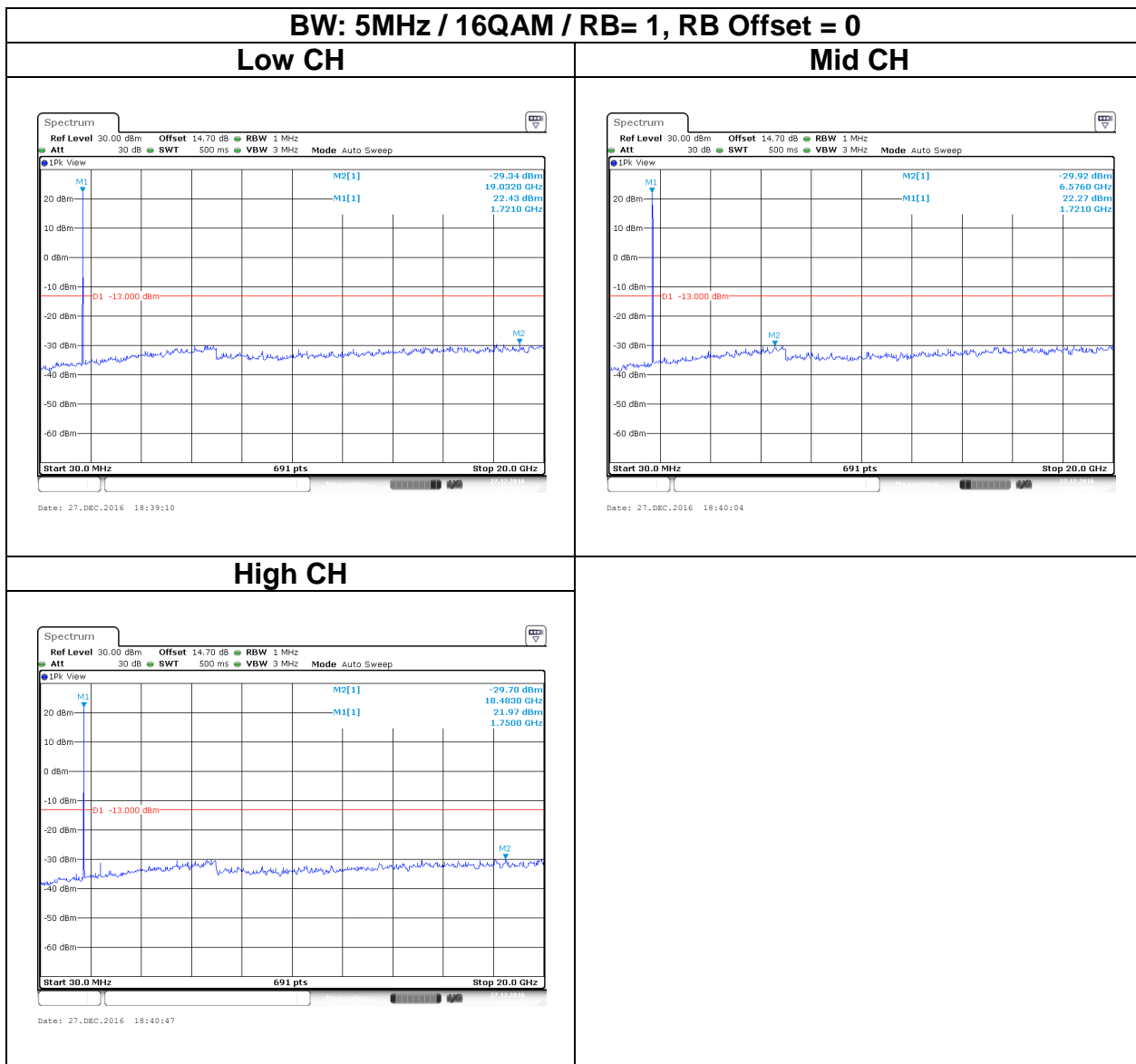

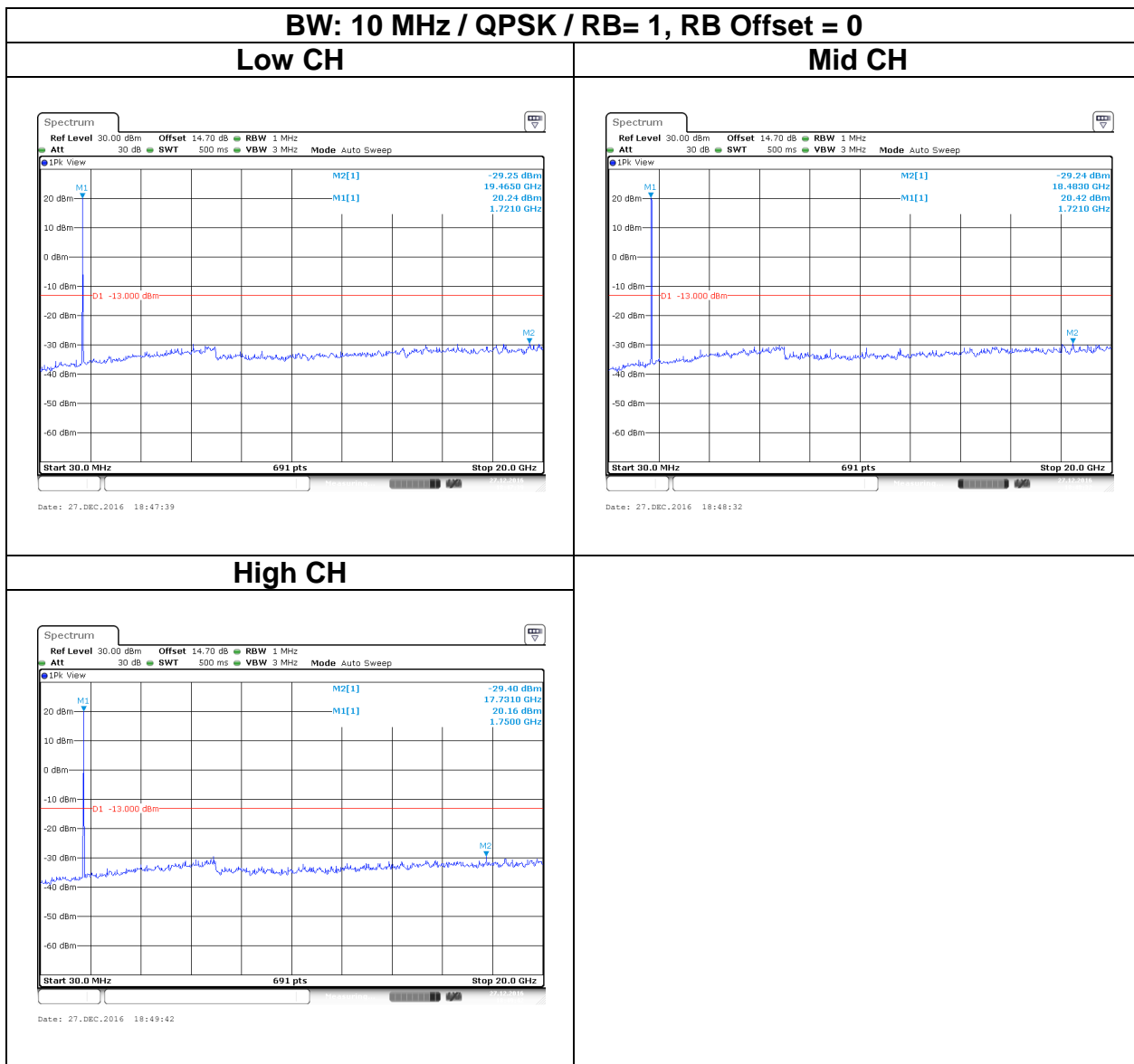

**BW: 10MHz / 16QAM / RB= 1, RB Offset = 0**

**Low CH**

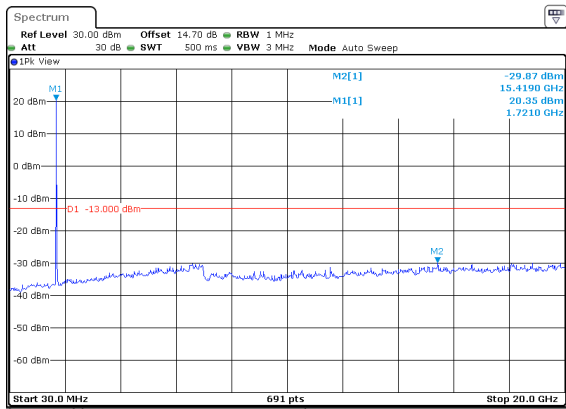

Date: 27.DEC.2016 18:41:57

**Mid CH**

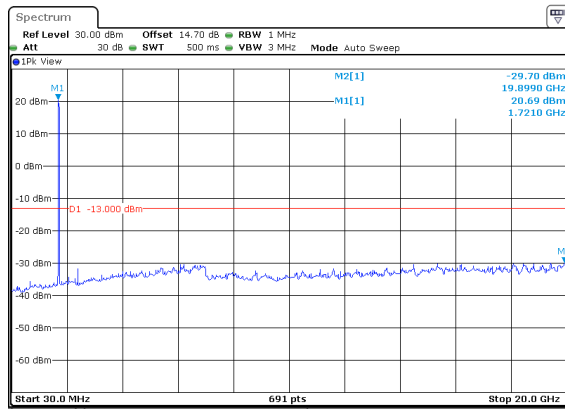

Date: 27.DEC.2016 18:42:48

**High CH**

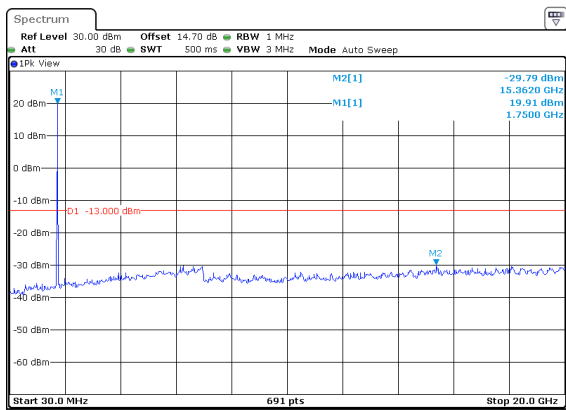

Date: 27.DEC.2016 18:43:26

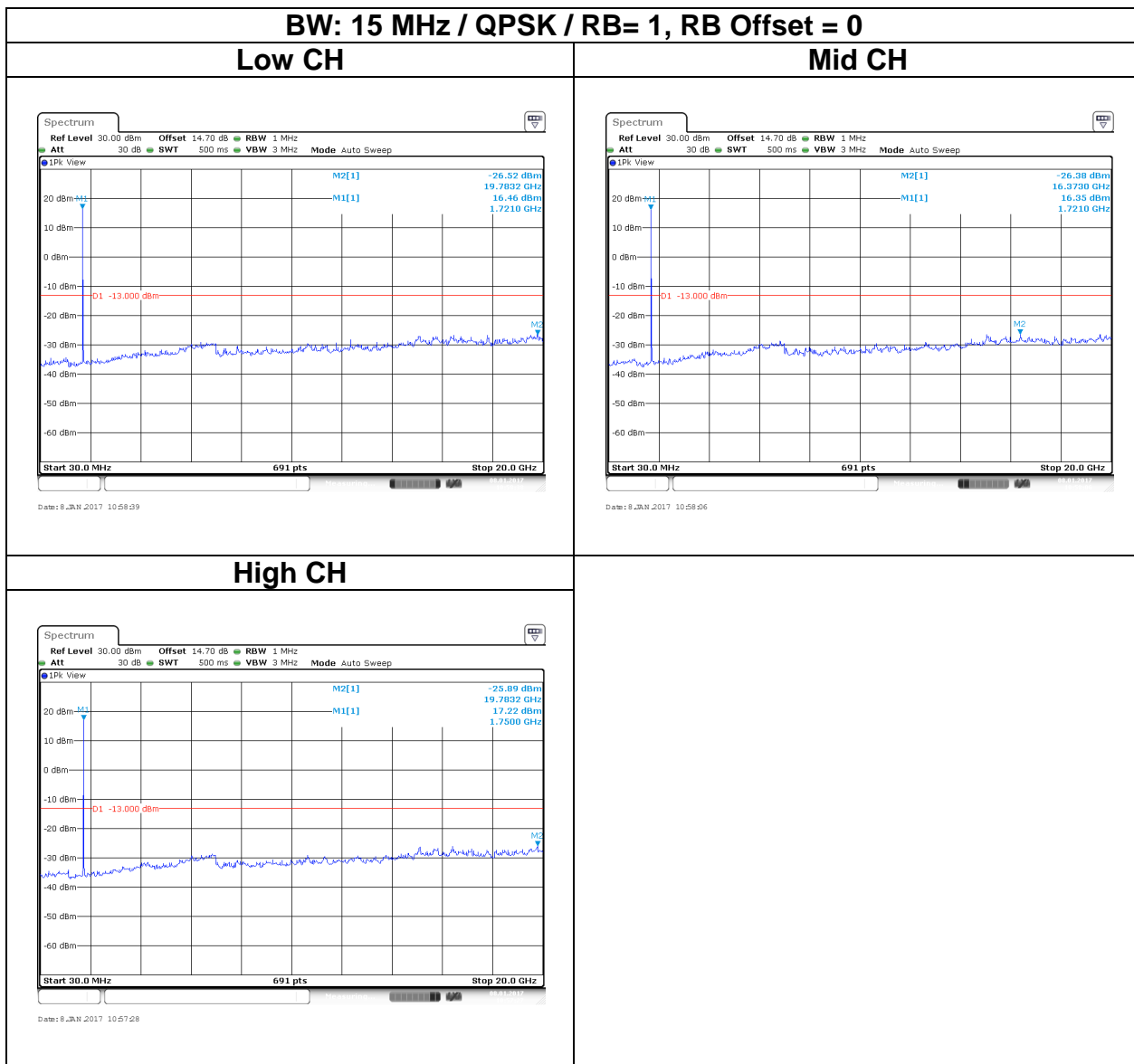

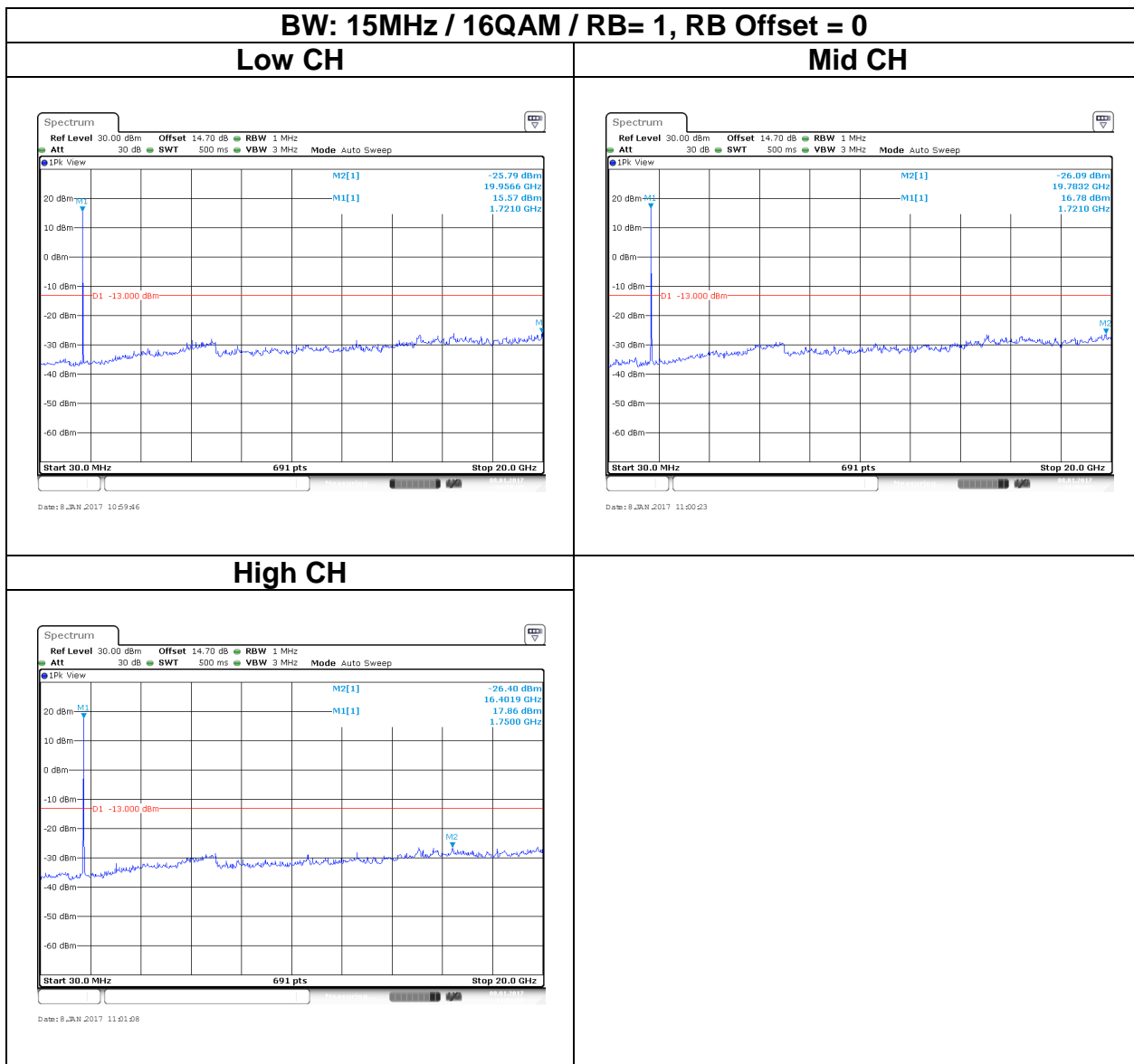

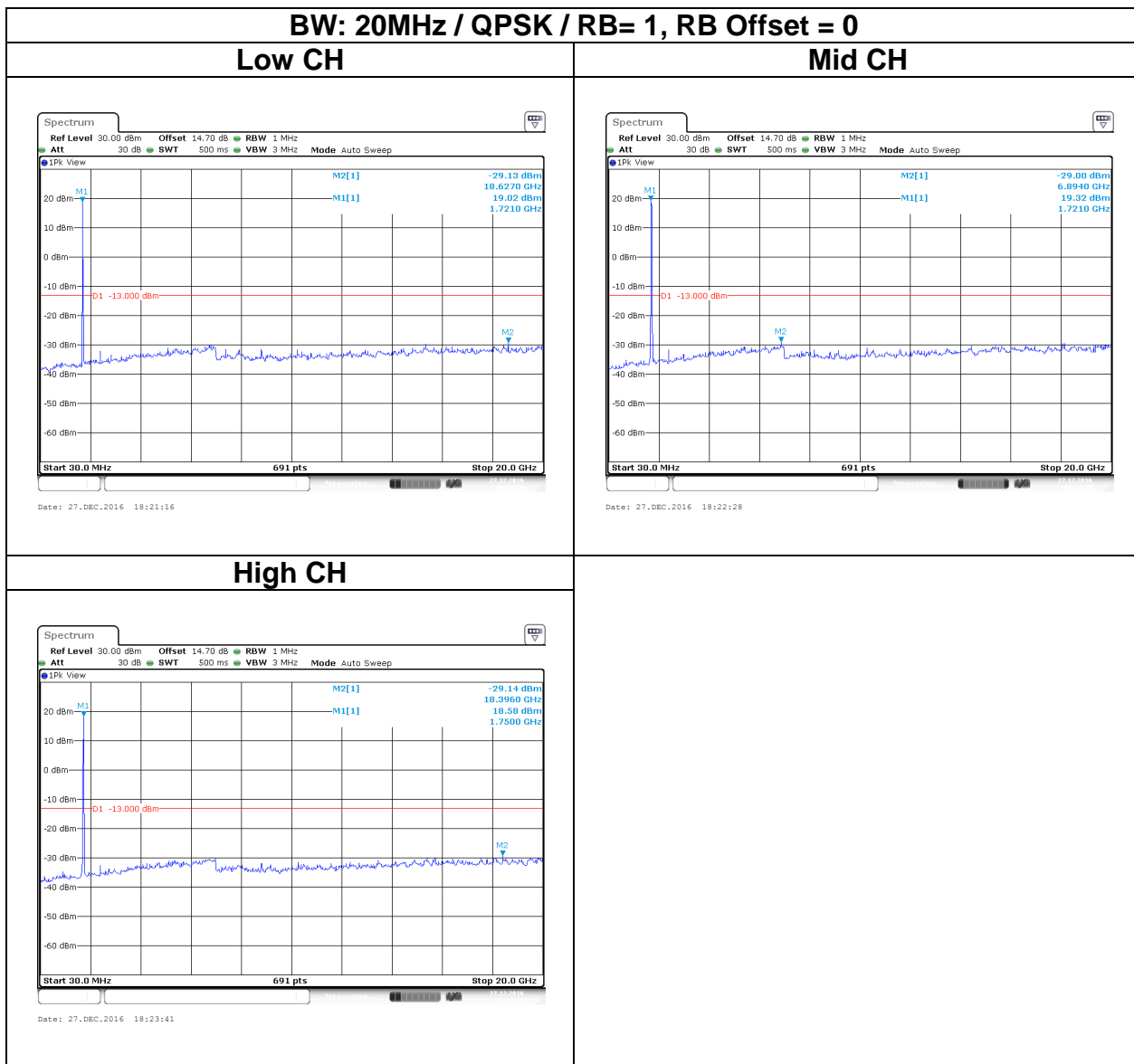

**BW: 20MHz / 16QAM / RB= 1, RB Offset = 0**

**Low CH**

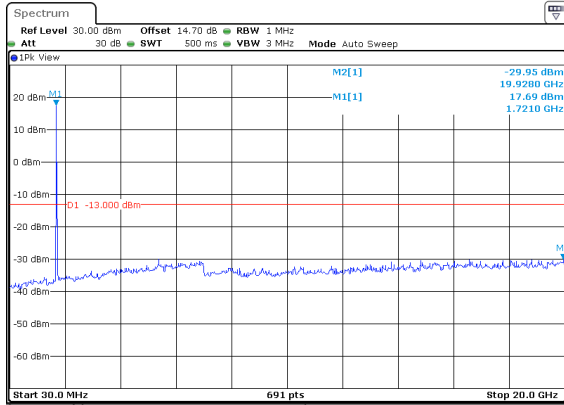

**Mid CH**

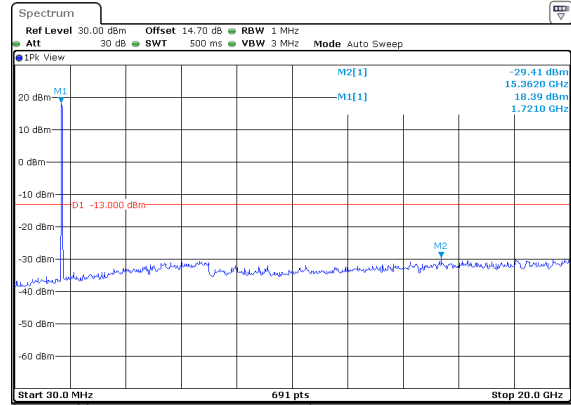

**High CH**

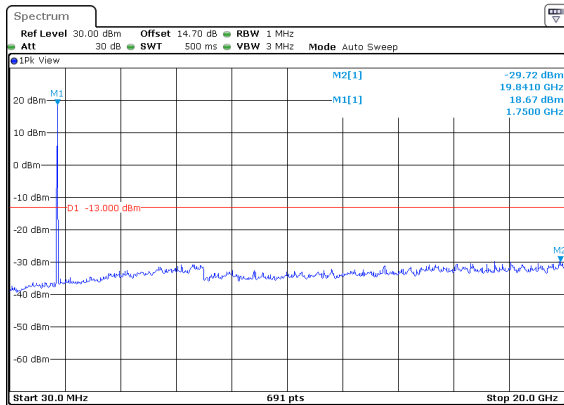

## **3.6 RADIATION EMISSION**

### **3.6.1 Test Limit**

According to FCC §27.53(h), Band 4

General protection levels. Except as otherwise specified below, for operations in the 1710-1755MHz bands, the power of any emission outside a licensee's frequency block shall be attenuated below the transmitter power (P) in watts by at least  $43 + 10 \log_{10} (P)$  dB.

Limit Line: -13dBm



### **3.6.2 Test Procedure**

According to KDB 971168 D01. section 5.8 and TIA-603-D:2010 section 2.2.12,.

1. The EUT was placed on a turntable

(1) Below 1G : 0.8m

(2) Above 1G : 1.5m

(3) EUT set 3m from the receiving antenna

(4) The table was rotated 360 degrees of the highest spurious emission to determine the position.

2. Set the spectrum analyzer , RBW=1MHz, VBW=3MHz.

3. A horn antenna was driven by a signal generator.

4. Tune the output power of signal generator to the same emission level with EUT maximum spurious emission

### 3.6.3 Test Setup

#### Below 1GHz

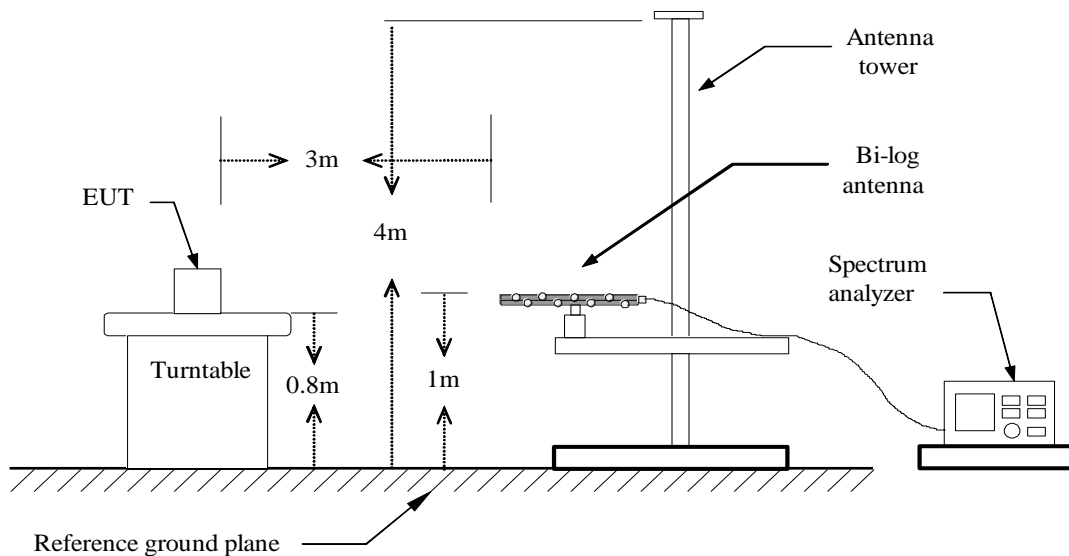

#### Above 1 GHz

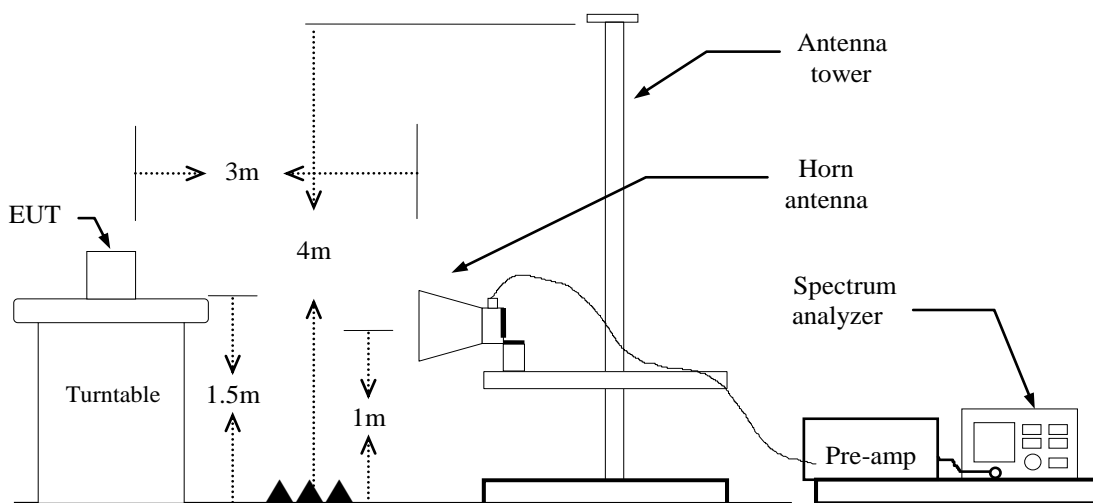

## Substituted Method Test Set-up

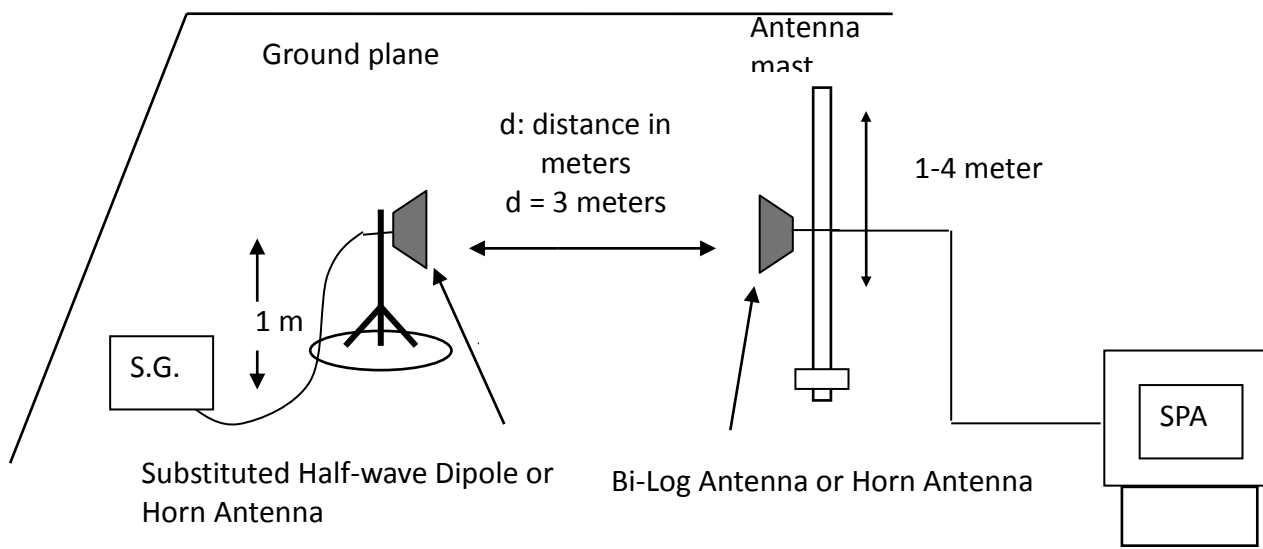

### 3.6.4 Test Result

#### Test Data

#### LTE Band 4

#### Below 1G Test Data

Test Mode	BW: 20MHz / QPSK / RB =1, RB Offset = 0 Mid CH	Temp/Hum	27(°C)/ 53%RH
Test Item	Below 1G	Test Date	Jan 05, 2017
Polarize	Vertical	Test Engineer	Dennis Li
Detector	Peak and Qusi-Peak	Test Voltage	120Vac / 60Hz

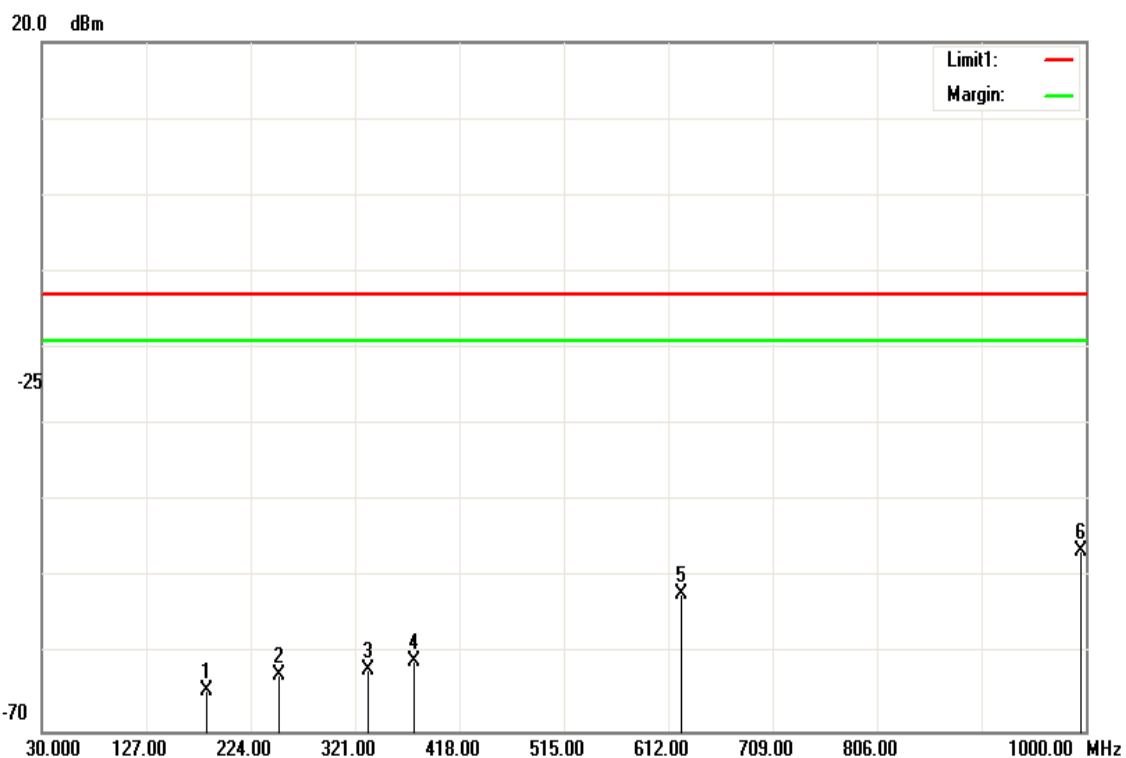

Frequency (MHz)	S.G. (dBm)	Ant Gain (dBi)	Result (dBm)	Limit (dBm)	Margin (dB)	Remark
183.2600	68.9	4.1	-64.80	-13.00	-51.80	Peak
250.1900	-70.1	7.4	-62.70	-13.00	-49.70	Peak
333.6100	-68.95	7.03	-61.92	-13.00	-48.92	Peak
375.3200	-68.06	7.2	-60.86	-13.00	-47.86	Peak
624.6400	-51.99	-0.17	-52.16	-13.00	-39.16	Peak
995.1500	-52.58	6.09	-46.49	-13.00	-33.49	Peak

Test Mode	BW: 20MHz / QPSK / RB =1, RB Offset = 0 Mid CH	Temp/Hum	27(°C)/ 53%RH
Test Item	Below 1G	Test Date	Jan 05, 2017
Polarize	Horizontal	Test Engineer	Dennis Li
Detector	Peak and Qusi-Peak	Test Voltage	120Vac / 60Hz

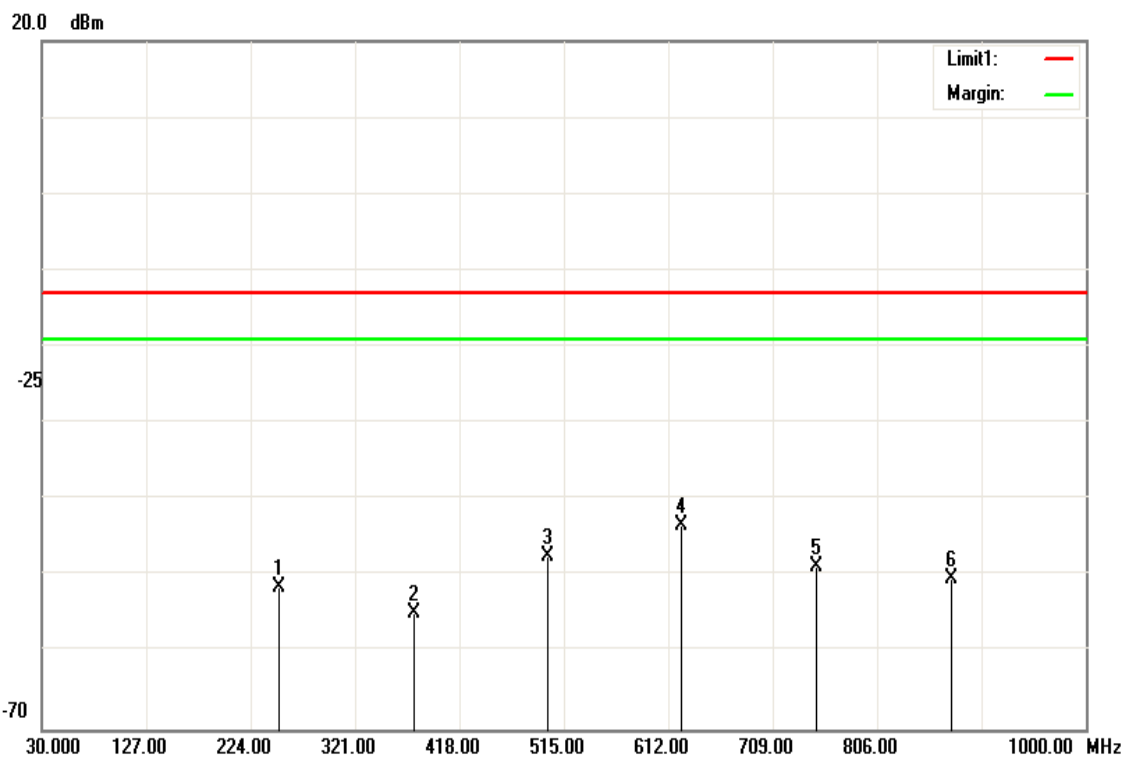

Frequency (MHz)	S.G. (dBm)	Ant Gain (dBi)	Result (dBm)	Limit (dBm)	Margin (dB)	Remark
250.190	-58.78	7.4	-51.38	-13.00	-38.38	Peak
375.3200	-61.97	7.2	-54.77	-13.00	-41.77	Peak
500.4500	-54.15	6.8	-47.35	-13.00	-34.35	Peak
624.6100	-43.1	-0.17	-43.27	-13.00	-30.27	Peak
749.7400	-50.35	1.67	-48.68	-13.00	-35.68	Peak
874.8700	-51.72	1.31	-50.41	-13.00	-37.41	Peak

Test Mode	BW: 20MHz / 16QAM / RB =1, RB Offset = 0 Mid CH	Temp/Hum	27(°C)/ 53%RH
Test Item	Below 1G	Test Date	Jan 05, 2017
Polarize	Vertical	Test Engineer	Dennis Li
Detector	Peak and Qusi-Peak	Test Voltage	120Vac / 60Hz

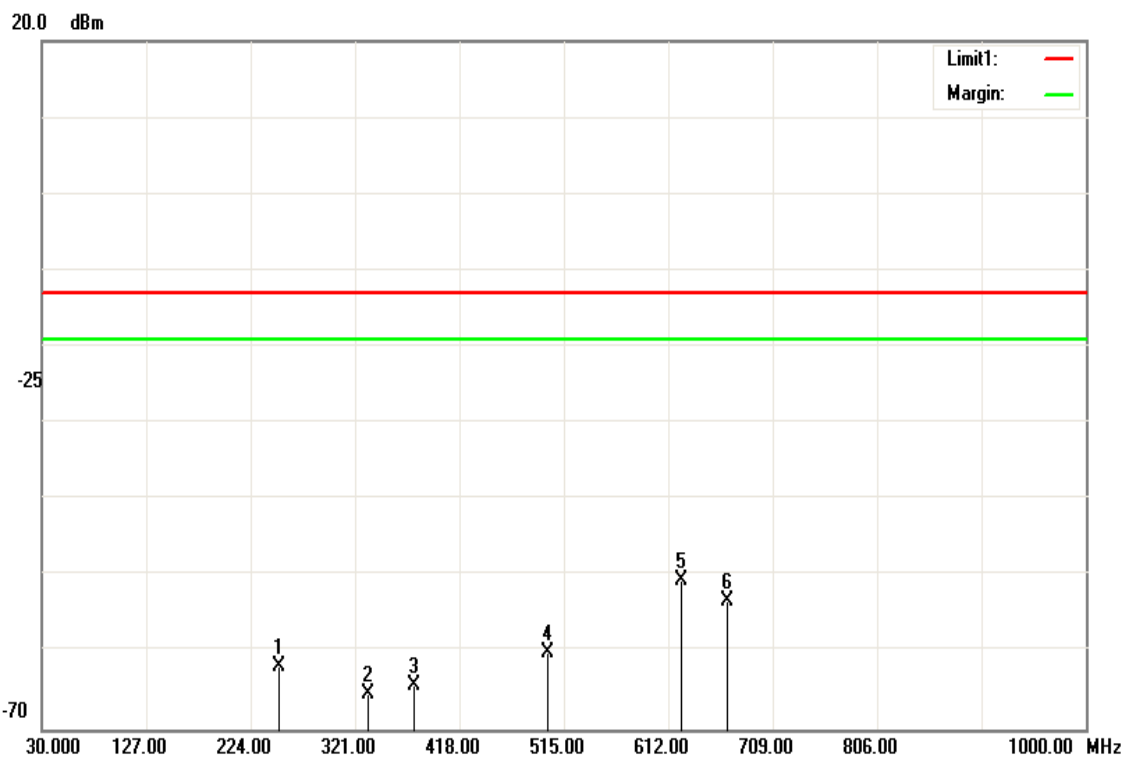

Frequency (MHz)	S.G. (dBm)	Ant Gain (dBi)	Result (dBm)	Limit (dBm)	Margin (dB)	Remark
250.1900	-69.3	7.4	-61.90	-13.00	-48.90	Peak
333.6100	-72.35	7.03	-65.32	-13.00	-52.32	Peak
375.3200	-71.52	7.2	-64.32	-13.00	-51.32	Peak
500.4500	-66.8	6.8	-60.00	-13.00	-47.00	Peak
624.6100	-50.28	-0.17	-50.45	-13.00	-37.45	Peak
666.3200	-54.76	1.54	-53.22	-13.00	-40.22	Peak

Test Mode	BW: 20MHz / 16QAM / RB =1, RB Offset = 0 Mid CH	Temp/Hum	27(°C)/ 53%RH
Test Item	Below 1G	Test Date	Jan 05, 2017
Polarize	Horizontal	Test Engineer	Dennis Li
Detector	Peak and Qusi-Peak	Test Voltage	120Vac / 60Hz

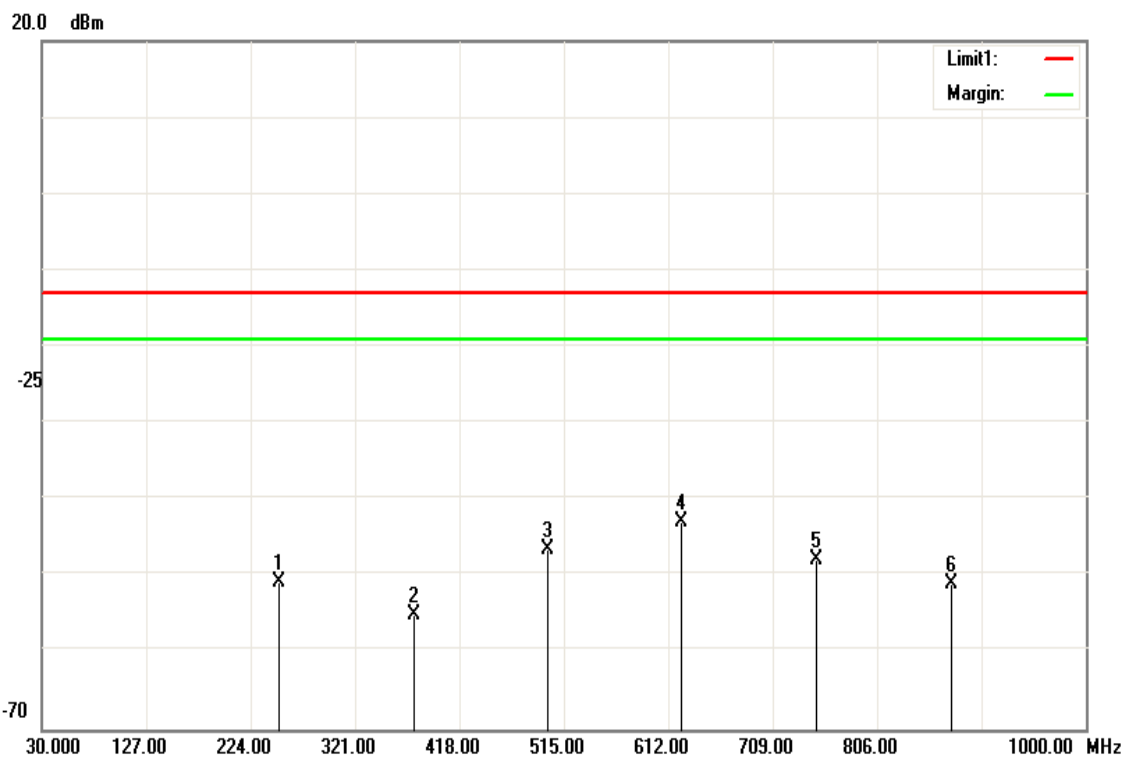

Frequency (MHz)	S.G. (dBm)	Ant Gain (dBi)	Result (dBm)	Limit (dBm)	Margin (dB)	Remark
250.1900	-58.07	7.4	-50.67	-13.00	-37.67	Peak
375.3200	-62.15	7.2	-54.95	-13.00	-41.95	Peak
500.4500	-53.27	6.8	-46.47	-13.00	-33.47	Peak
624.6100	-42.8	-0.17	-42.97	-13.00	-29.97	Peak
749.7400	-49.45	1.67	-47.78	-13.00	-34.78	Peak
874.8700	-52.38	1.31	-51.07	-13.00	-38.07	Peak

**Above 1G Test Data**

Test Mode	BW: 20MHz / QPSK / RB =1, RB Offset = 0 Low CH	Temp/Hum	27(°C)/ 53%RH
Test Item	Above 1G	Test Date	Jan 05, 2017
Polarize	Horizontal	Test Engineer	Dennis Li
Detector	Peak and Average	Test Voltage	120Vac / 60Hz

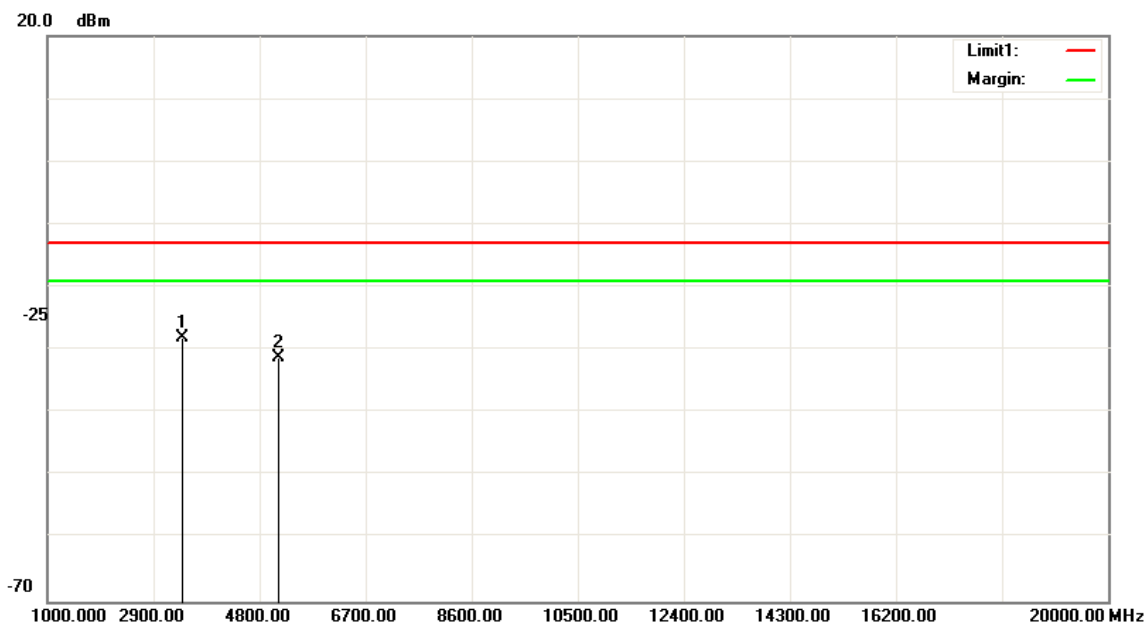

Frequency (MHz)	Reading (dBuV)	Correct Factor (dB/m)	Result (dBuV/m)	Limit (dBuV/m)	Margin (dB)	Remark
3422.000	-40.26	12.3	-27.96	-13.00	-14.96	Peak
5130.000	-43.81	12.6	-31.21	-13.00	-18.21	Peak

1. Measuring frequencies from 1 GHz to the 10th harmonic of highest fundamental frequency.



Test Mode	BW: 20MHz / QPSK / RB =1, RB Offset = 0 Low CH	Temp/Hum	27(°C)/ 53%RH
Test Item	Above 1G	Test Date	Jan 05, 2017
Polarize	Vertical	Test Engineer	Dennis Li
Detector	Peak and Average	Test Voltage	120Vac / 60Hz

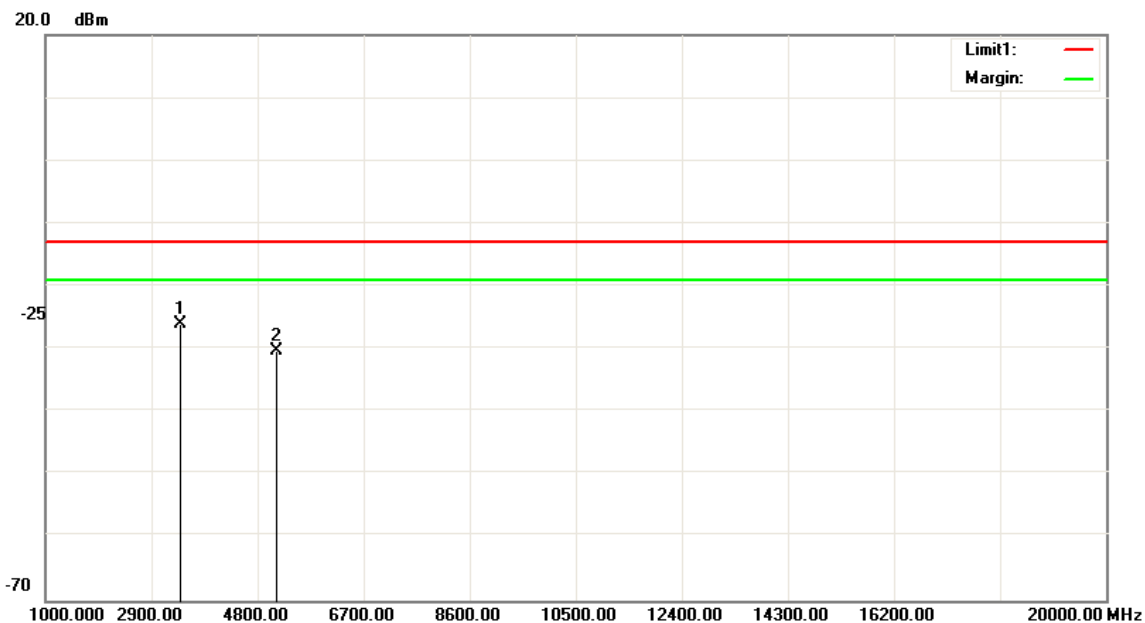

Frequency (MHz)	Reading (dBuV)	Correct Factor (dB/m)	Result (dBuV/m)	Limit (dBuV/m)	Margin (dB)	Remark
3422.000	-38.34	12.3	-26.04	-13.00	-13.04	Peak
5130.000	-42.99	12.6	-30.39	-13.00	-17.39	Peak

1. Measuring frequencies from 1 GHz to the 10th harmonic of highest fundamental frequency.

Test Mode	BW: 20MHz / 16QAM / RB =1, RB Offset = 0 Low CH	Temp/Hum	27(°C)/ 53%RH
Test Item	Above 1G	Test Date	Jan 05, 2017
Polarize	Horizontal	Test Engineer	Dennis Li
Detector	Peak and Average	Test Voltage	120Vac / 60Hz

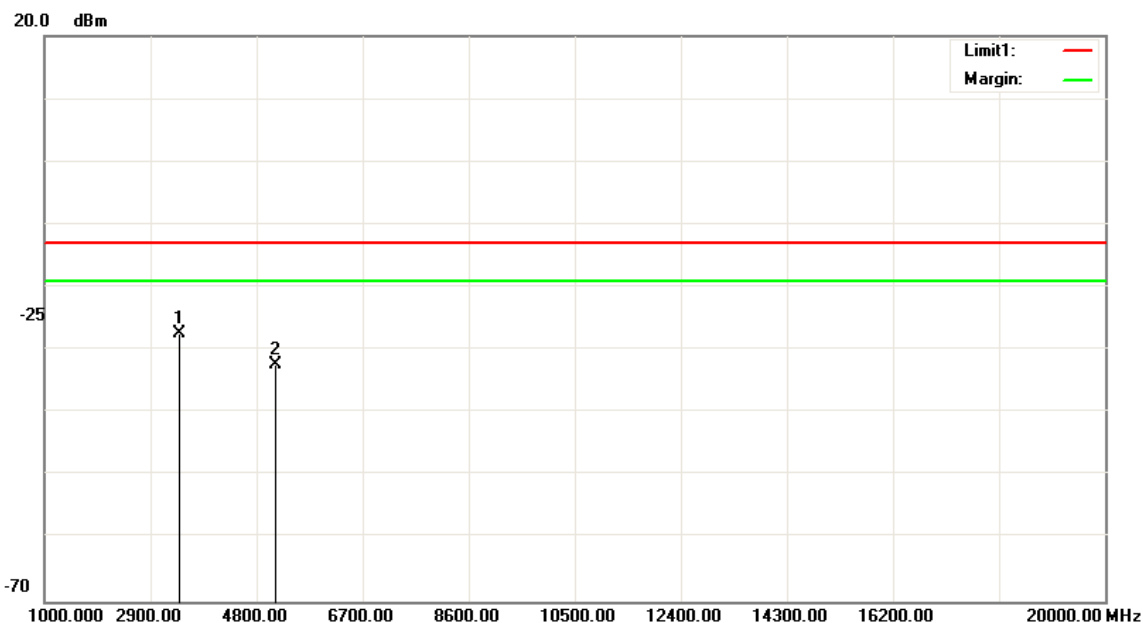

Frequency (MHz)	Reading (dBuV)	Correct Factor (dB/m)	Result (dBuV/m)	Limit (dBuV/m)	Margin (dB)	Remark
3422.000	-39.59	12.3	-27.29	-13.00	-14.29	Peak
5130.000	-44.94	12.6	-32.34	-13.00	-19.34	Peak

1. Measuring frequencies from 1 GHz to the 10th harmonic of highest fundamental frequency.

Test Mode	BW: 20MHz / 16QAM / RB =1, RB Offset = 0 Low CH	Temp/Hum	27(°C)/ 53%RH
Test Item	Above 1G	Test Date	Jan 05, 2017
Polarize	Vertical	Test Engineer	Dennis Li
Detector	Peak and Average	Test Voltage	120Vac / 60Hz

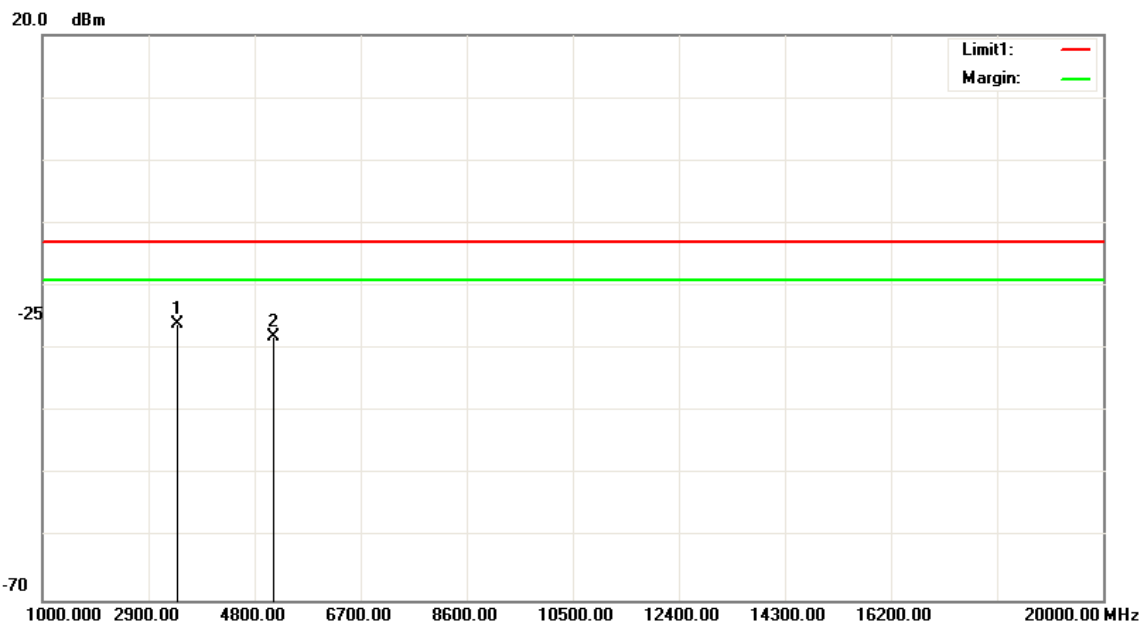

Frequency (MHz)	Reading (dBuV)	Correct Factor (dB/m)	Result (dBuV/m)	Limit (dBuV/m)	Margin (dB)	Remark
3422.000	-38.23	12.3	-25.93	-13.00	-12.93	Peak
5130.000	-40.56	12.6	-27.96	-13.00	-14.96	Peak

1. Measuring frequencies from 1 GHz to the 10th harmonic of highest fundamental frequency.

Test Mode	BW: 20MHz / QPSK / RB =1, RB Offset = 0 Mid CH	Temp/Hum	27(°C)/ 53%RH
Test Item	Above 1G	Test Date	Jan 05, 2017
Polarize	Horizontal	Test Engineer	Dennis Li
Detector	Peak and Average	Test Voltage	120Vac / 60Hz

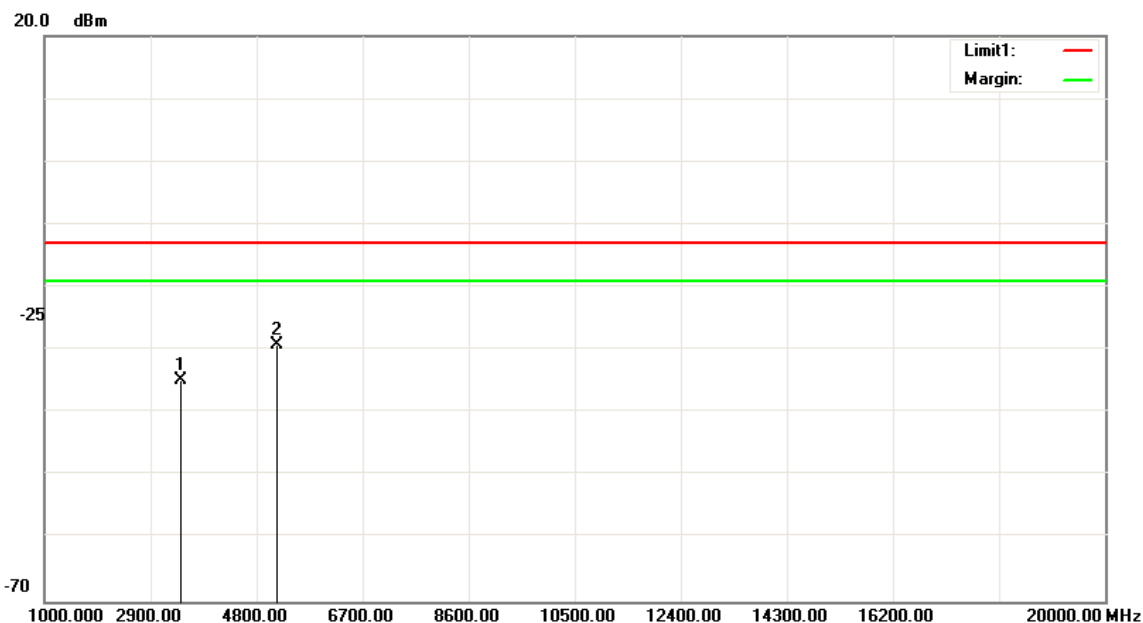

Frequency (MHz)	Reading (dBuV)	Correct Factor (dB/m)	Result (dBuV/m)	Limit (dBuV/m)	Margin (dB)	Remark
3450.000	-47.23	12.37	-34.86	-13.00	-21.86	Peak
5172.000	-41.89	12.64	-29.25	-13.00	-16.25	Peak

1. Measuring frequencies from 1 GHz to the 10th harmonic of highest fundamental frequency.

Test Mode	BW: 20MHz / QPSK / RB =1, RB Offset = 0 Mid CH	Temp/Hum	27(°C)/ 53%RH
Test Item	Above 1G	Test Date	Jan 05, 2017
Polarize	Vertical	Test Engineer	Dennis Li
Detector	Peak and Average	Test Voltage	120Vac / 60Hz

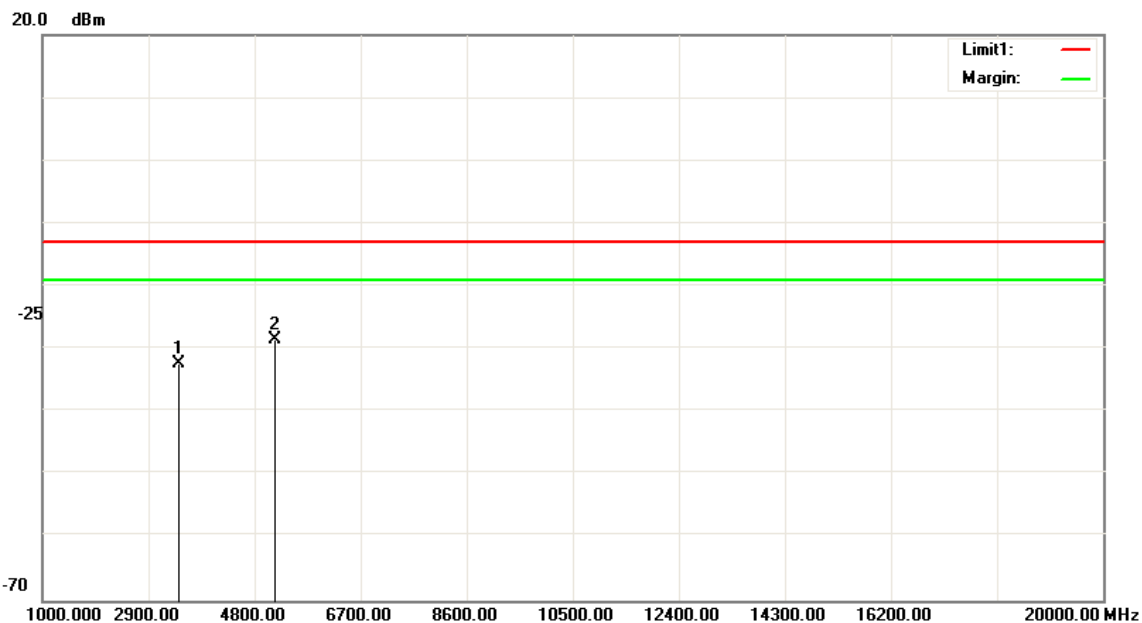

Frequency (MHz)	Reading (dBuV)	Correct Factor (dB/m)	Result (dBuV/m)	Limit (dBuV/m)	Margin (dB)	Remark
3450.000	-44.65	12.37	-32.28	-13.00	-19.28	Peak
5172.000	-41.14	12.64	-28.50	-13.00	-15.50	Peak

1. Measuring frequencies from 1 GHz to the 10th harmonic of highest fundamental frequency.

Test Mode	BW: 20MHz / 16QAM / RB =1, RB Offset = 0 Mid CH	Temp/Hum	27(°C)/ 53%RH
Test Item	Above 1G	Test Date	Jan 05, 2017
Polarize	Horizontal	Test Engineer	Dennis Li
Detector	Peak and Average	Test Voltage	120Vac / 60Hz

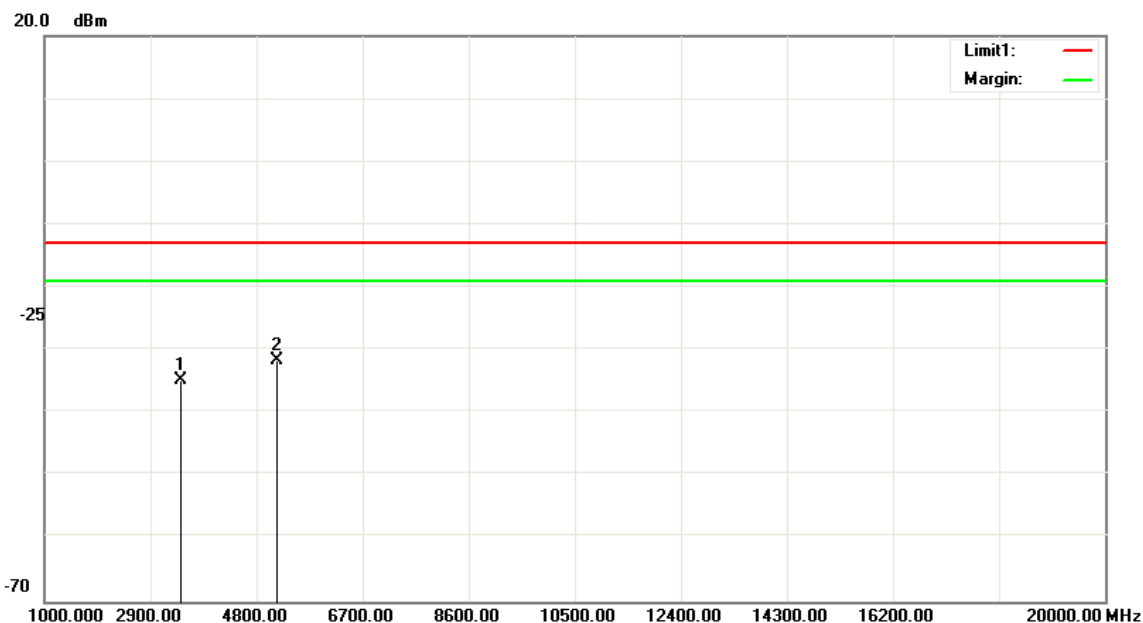

Frequency (MHz)	Reading (dBuV)	Correct Factor (dB/m)	Result (dBuV/m)	Limit (dBuV/m)	Margin (dB)	Remark
3450.000	-47.09	12.37	-34.72	-13.00	-21.72	Peak
5172.000	-44.31	12.64	-31.67	-13.00	-18.67	Peak

1. Measuring frequencies from 1 GHz to the 10th harmonic of highest fundamental frequency.

Test Mode	BW: 20MHz / 16QAM / RB =1, RB Offset = 0 Mid CH	Temp/Hum	27(°C)/ 53%RH
Test Item	Above 1G	Test Date	Jan 05, 2017
Polarize	Vertical	Test Engineer	Dennis Li
Detector	Peak and Average	Test Voltage	120Vac / 60Hz

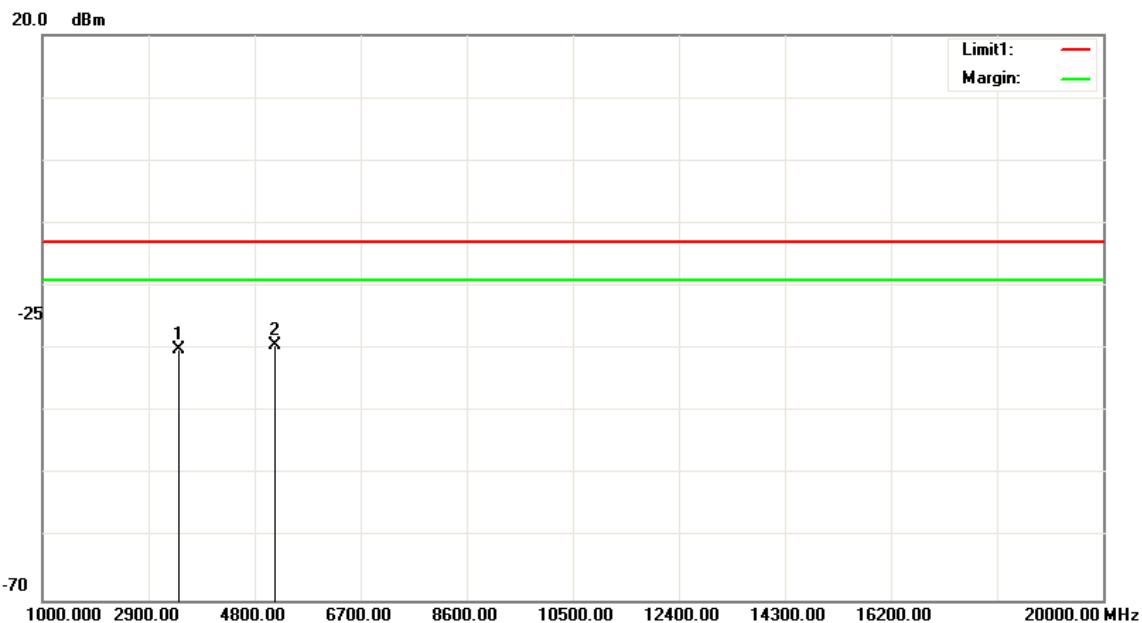

Frequency (MHz)	Reading (dBuV)	Correct Factor (dB/m)	Result (dBuV/m)	Limit (dBuV/m)	Margin (dB)	Remark
3450.000	-42.39	12.37	-30.02	-13.00	-17.02	Peak
5172.000	-42.12	12.64	-29.48	-13.00	-16.48	Peak

1. Measuring frequencies from 1 GHz to the 10th harmonic of highest fundamental frequency.

Test Mode	BW: 20MHz / QPSK / RB =1, RB Offset = 0 High CH	Temp/Hum	27(°C)/ 53%RH
Test Item	Above 1G	Test Date	Jan 05, 2017
Polarize	Horizontal	Test Engineer	Dennis Li
Detector	Peak and Average	Test Voltage	120Vac / 60Hz

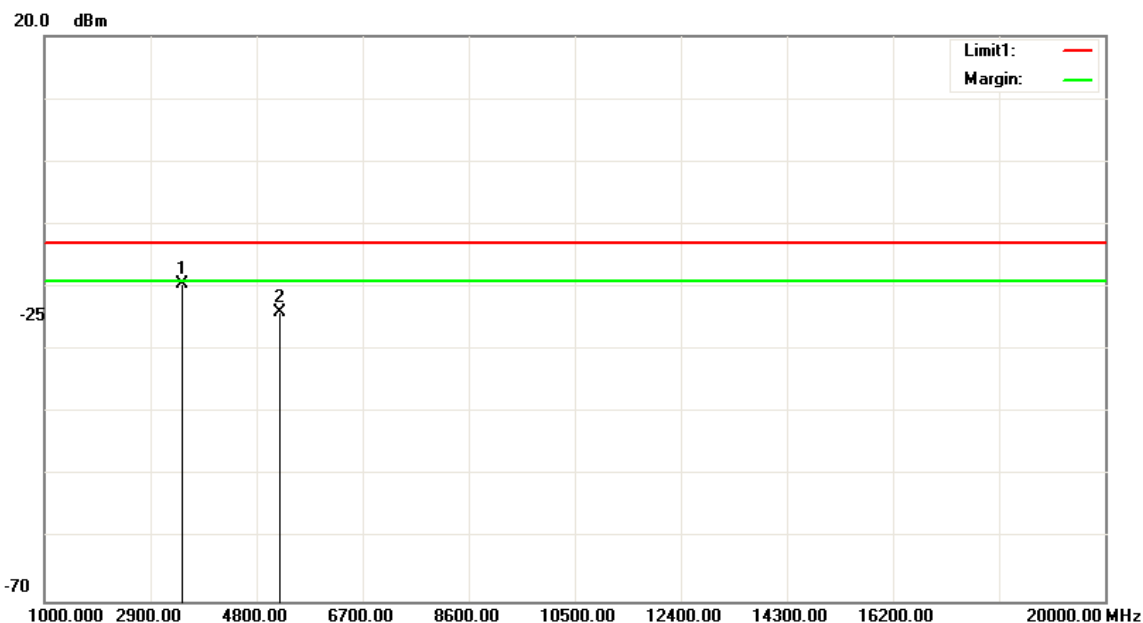

Frequency (MHz)	Reading (dBuV)	Correct Factor (dB/m)	Result (dBuV/m)	Limit (dBuV/m)	Margin (dB)	Remark
3471.000	-32	12.42	-19.58	-13.00	-6.58	Peak
5207.000	-36.56	12.67	-23.89	-13.00	-10.89	Peak

1. Measuring frequencies from 1 GHz to the 10th harmonic of highest fundamental frequency.



Test Mode	BW: 20MHz / QPSK / RB =1, RB Offset = 0 High CH	Temp/Hum	27(°C)/ 53%RH
Test Item	Above 1G	Test Date	Jan 05, 2017
Polarize	Vertical	Test Engineer	Dennis Li
Detector	Peak and Average	Test Voltage	120Vac / 60Hz

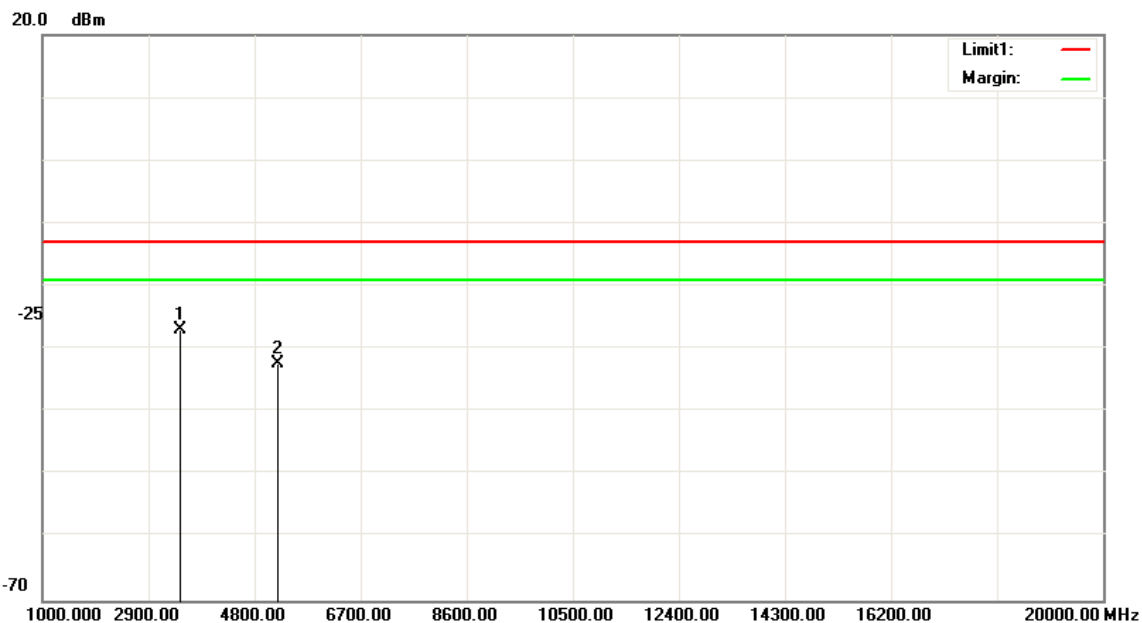

Frequency (MHz)	Reading (dBuV)	Correct Factor (dB/m)	Result (dBuV/m)	Limit (dBuV/m)	Margin (dB)	Remark
3471.000	-39.38	12.42	-26.96	-13.00	-13.96	Peak
5207.000	-45.05	12.67	-32.38	-13.00	-19.38	Peak

1. Measuring frequencies from 1 GHz to the 10th harmonic of highest fundamental frequency.

Test Mode	BW: 20MHz / 16QAM / RB =1, RB Offset = 0 High CH	Temp/Hum	27(°C)/ 53%RH
Test Item	Above 1G	Test Date	Jan 05, 2017
Polarize	Horizontal	Test Engineer	Dennis Li
Detector	Peak and Average	Test Voltage	120Vac / 60Hz

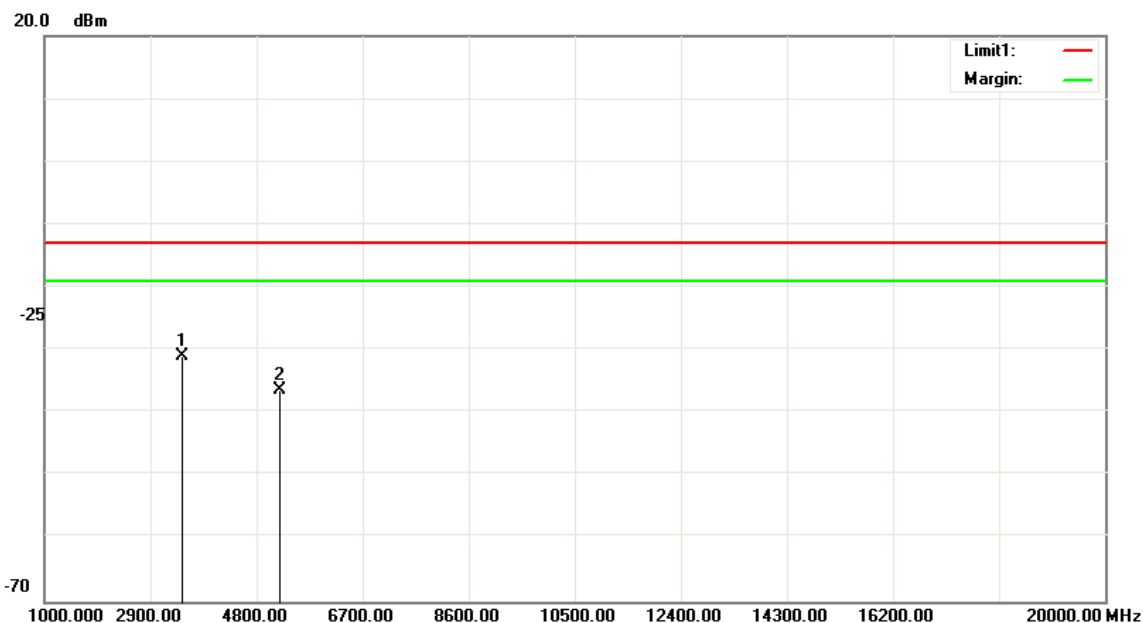

Frequency (MHz)	Reading (dBuV)	Correct Factor (dB/m)	Result (dBuV/m)	Limit (dBuV/m)	Margin (dB)	Remark
3471.000	-43.28	12.42	-30.86	-13.00	-17.86	Peak
5207.000	-49.03	12.67	-36.36	-13.00	-23.36	Peak

1. Measuring frequencies from 1 GHz to the 10th harmonic of highest fundamental frequency.

Test Mode	BW: 20MHz / 16QAM / RB =1, RB Offset = 0 High CH	Temp/Hum	27(°C)/ 53%RH
Test Item	Above 1G	Test Date	Jan 05, 2017
Polarize	Vertical	Test Engineer	Dennis Li
Detector	Peak and Average	Test Voltage	120Vac / 60Hz

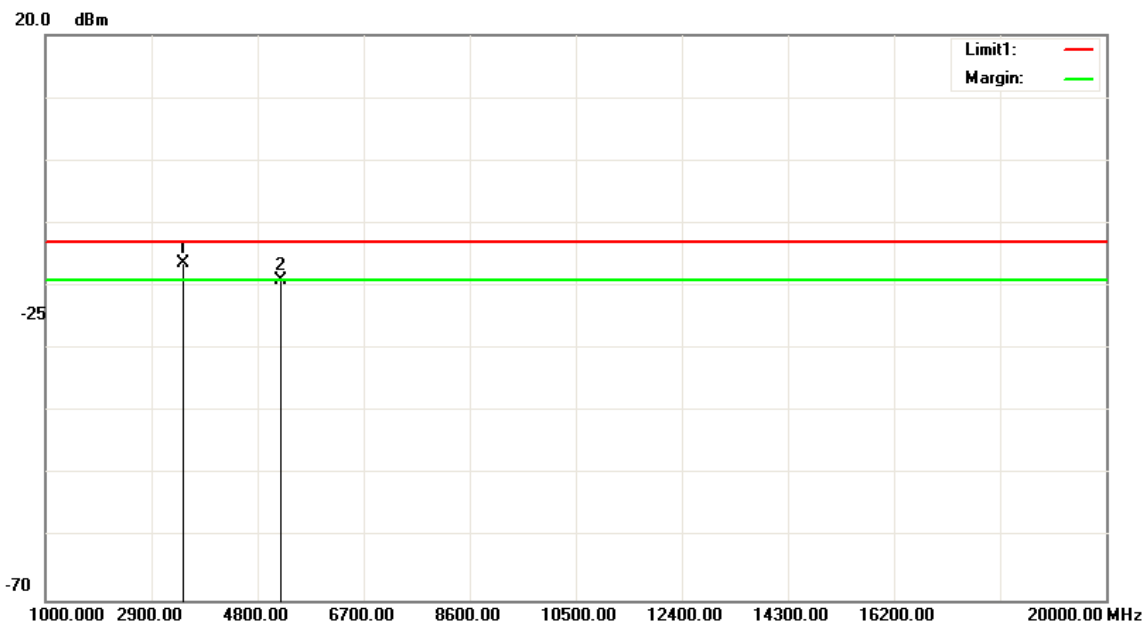

Frequency (MHz)	Reading (dBuV)	Correct Factor (dB/m)	Result (dBuV/m)	Limit (dBuV/m)	Margin (dB)	Remark
3471.000	-28.78	12.42	-16.36	-13.00	-3.36	Peak
5207.000	-31.7	12.67	-19.03	-13.00	-6.03	Peak

1. Measuring frequencies from 1 GHz to the 10th harmonic of highest fundamental frequency.

## 3.7 FREQUENCY STABILITY

### 3.7.1 Test Limit

According to the FCC part 27.54 shall be tested the frequency stability. The rule is defined that "The frequency stability shall be sufficient to ensure that the fundamental emissions stay within the authorized bands of operation.

### 3.7.2 Test Procedure

Use Anritsu 8820 with frequency Error measurement capability

Temp = -30 to +50°C

Voltage= 85% to 115% of the nominal value for AC powered equipment The equipment.

### 3.7.3 Test Setup

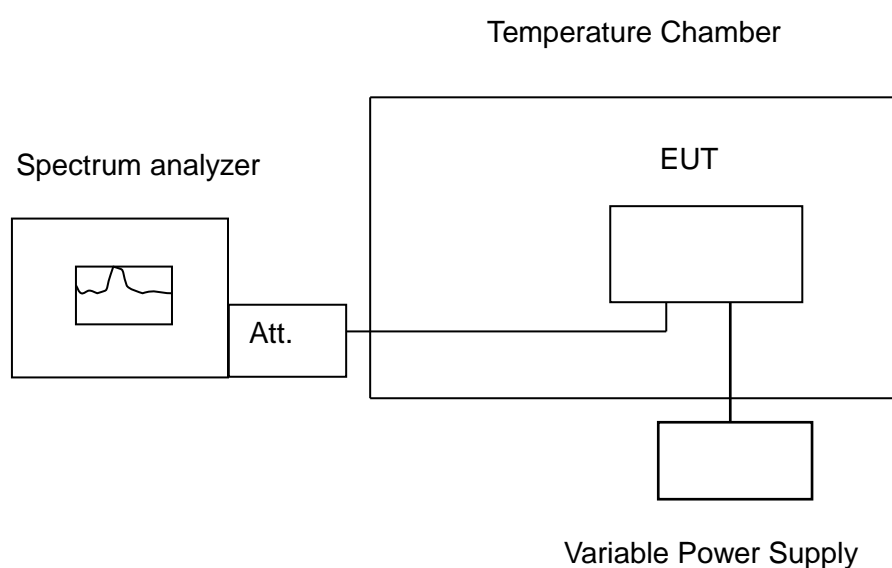

### 3.7.4 Test Result

We selected the worst-case mode to perform the test.

**FREQUENCY STABILITY V.S. TEMPERATURE MEASUREMENT:**

Reference Frequency: LTE Band 4, 1732.5 MHz_QPSK				
Limit: 2.5 ppm = 4331.25Hz				
Power Supply (Vac)	Environment Temperature (°C)	BW: 20M Frequency Error(Hz)	Frequency Error (ppm)	Limit (ppm)
120	50	-2.98	-0.0017	+/- 2.5
120	40	-2.39	-0.0014	
120	30	-3.36	-0.0019	
120	20	-2.10	-0.0012	
120	10	-3.70	-0.0021	
120	0	-2.07	-0.0012	
120	-10	-2.43	-0.0014	
120	-20	-5.22	-0.0030	
120	-30	-2.98	-0.0017	

**FREQUENCY STABILITY V.S. VOLTAGE MEASUREMENT:**

Reference Frequency: LTE Band 4, 1732.5 MH_QPSK				
Limit: 2.5 ppm = 4331.25Hz				
Power Supply (Vac)	Environment Temperature (°C)	BW: 20M Frequency Error(Hz)	Frequency Error (ppm)	Limit (ppm)
138	20	-4.13	-0.0024	+/- 2.5
120		-2.10	-0.0012	
102		-3.95	-0.0023	

**FREQUENCY STABILITY V.S. TEMPERATURE MEASUREMENT:**

<b>Reference Frequency: LTE Band 4, 1732.5 MHz_16QAM</b>				
Limit: 2.5 ppm = 4331.25Hz				
Power Supply (Vac)	Environment Temperature (°C)	BW: 20M Frequency Error(Hz)	Frequency Error (ppm)	Limit (ppm)
120	50	-2.93	-0.0017	+/- 2.5
120	40	-2.32	-0.0014	
120	30	-3.33	-0.0019	
120	20	-2.05	-0.0012	
120	10	-3.66	-0.0021	
120	0	-2.02	-0.0012	
120	-10	-2.39	-0.0014	
120	-20	-5.18	-0.0030	
120	-30	-2.93	-0.0017	

**FREQUENCY STABILITY V.S. VOLTAGE MEASUREMENT:**

<b>Reference Frequency: LTE Band 4, 1732.5 MH_16QAM</b>				
Limit: 2.5 ppm = 4331.25Hz				
Power Supply (Vac)	Environment Temperature (°C)	BW: 20M Frequency Error(Hz)	Frequency Error (ppm)	Limit (ppm)
138	20	-4.09	-0.0024	+/- 2.5
120		-2.05	-0.0012	
102		-3.89	-0.0023	