



Test Report No:
23A0648R-RFUSV01S-A

TEST REPORT

FCC Rules&Regulations

Product Name	Communication Module
Brand Name	muRata
Model No.	LBEE5XV1YM
FCC ID	QHQLB1YM
Applicant's Name / Address	Laerdal Medical AS Tanke Svilandsgate 30 P.O. Box 377, Stavanger, 4002 Norway
Manufacturer's Name / Address	Murata Manufacturing Co., Ltd. 1-10-1, Higashikotari, Nagaokakyo-shi, Kyoto 617-8555 Japan
Test Method Requested, Standard	FCC CFR Title 47 Part 15 Subpart C Section 15.247 ANSI C63.10-2013
Verdict Summary	IN COMPLIANCE
Documented By	<i>Hailey Peng</i> Hailey Peng
Approved By	<i>Allen Lin</i> Allen Lin
Date of Receipt	Oct. 25, 2023
Date of Issue	Dec. 15, 2023
Report Version	V1.0

INDEX

	page
Competences and Guarantees.....	3
General Conditions.....	3
Revision History.....	4
Permissive Change.....	5
Summary of Test Result.....	6
Comments and Remarks.....	6
1. General Information.....	7
1.1. EUT Description.....	7
1.2. EUT Information.....	7
1.3. Testing Applied Standards.....	8
1.4. Testing Location Information.....	8
1.5. Measurement Uncertainty.....	8
1.6. List of Test Equipment.....	9
2. Test Configuration of EUT.....	10
2.1. Test Condition.....	10
2.2. Test Frequency Mode.....	10
2.3. The Worst Case Measurement Configuration.....	11
2.4. Tested System Details.....	12
2.5. Configuration of Tested System.....	12
3. AC Power Line Conducted Emission.....	13
3.1. Test Setup.....	13
3.2. Test Limit.....	13
3.3. Test Procedure.....	13
3.4. Test Result of AC Power Line Conducted Emission.....	13
4. Maximum Conducted Output Power.....	14
4.1. Test Setup.....	14
4.2. Test Limit.....	14
4.3. Test Procedures.....	14
4.4. Test Result of Maximum Conducted Output Power.....	14
5. Transmitter Radiated Spurious Emission.....	15
5.1. Test Setup.....	15
5.2. Test Limit.....	16
5.3. Test Procedure.....	16
5.4. Test Result of Transmitter Radiated Spurious Emission.....	16
Appendix A. Test Result of AC Power Line Conducted Emission	
Appendix B. Test Result of Maximum Conducted Output Power	
Appendix C. Test Result of Transmitter Radiated Spurious Emission	
Appendix D. Test Result of Radiated Emissions Co-location	
Appendix E. Test Setup Photograph	

Competences and Guarantees

DEKRA is a testing laboratory competent to carry out the tests described in this report.

In order to assure the traceability to other national and international laboratories, DEKRA has a calibration and maintenance program for its measurement equipment.

DEKRA guarantees the reliability of the data presented in this report, which is the result of the measurements and the tests performed to the item under test on the date and under the conditions stated in the report and it is based on the knowledge and technical facilities available at DEKRA at the time of performance of the test.

DEKRA is liable to the client for the maintenance of the confidentiality of all information related to the item under test and the results of the test.

The results presented in this Test Report apply only to the particular item under test established in this document.

IMPORTANT: No parts of this report may be reproduced or quoted out of context, in any form or by any means, except in full, without the previous written permission of DEKRA.

General Conditions

1. The test results relate only to the samples tested.
2. The test results shown in the test report are traceable to the national/international standard through the calibration report of the equipment and evaluated measurement uncertainty herein.
3. This report must not be used to claim product endorsement by TAF or any agency of the government.
4. The test report shall not be reproduced without the written approval of DEKRA Testing and Certification Co., Ltd.
5. Measurement uncertainties evaluated for each testing system and associated connections are given here to provide the system information for reference. Compliance determinations do not take into account measurement uncertainties for each testing system, but are based on the results of the compliance measurement.

Revision History

Version	Description	Issued Date
V1.0	Initial issue of report	Dec. 15, 2023

Permissive Change

Permissive Change	Modifications
Class II Permissive Change (C2PC)	<ol style="list-style-type: none"><li data-bbox="633 349 1468 405">1. Additional platform added (Product: LinkBox PLUS 2, Brand: Laerdal Medical AS, Model: 204-00250).<li data-bbox="633 409 1468 470">2. Add two same type antennas (Type: dipole, model: GEPH-057 and model: GEPH-023) but higher gain than the original certificate. <p data-bbox="633 474 1468 553">After evaluating, it was verified for maximum conducted output power, AC power line conducted emission and transmitter radiated spurious emission tests and record in the report.</p>

Summary of Test Result

Report Clause	Test Items	Result (PASS/FAIL)	Remark
3	AC Power Line Conducted Emission	PASS	-
4	Maximum Conducted Output Power	PASS	-
5	Transmitter Radiated Spurious Emission	PASS	-

Note: The EUT was installed to the host (brand name: Laerdal Medical AS, model: 204-00250) to perform all the tests.

Comments and Explanations

The declared of product specification for EUT presented in the report are provided by the manufacturer, and the manufacturer takes all the responsibilities for the accuracy of product specification.

Comments and Remarks

The product specification and testing instructions for the EUT declared in the report are provided by the manufacturer who will take all responsibilities for the accuracy.

1. General Information

1.1. EUT Description

Frequency Range	2400 ~ 2483.5 MHz	
Operating Frequency	IEEE 802.11b/g IEEE 802.11n (20 MHz)	2412 ~ 2462 MHz
Channel Number	IEEE 802.11b/g IEEE 802.11n (20 MHz)	11 Channels
Type of Modulation	IEEE 802.11b	DSSS-DBPSK, DQPSK, CCK
	IEEE 802.11g/n	OFDM-BPSK, QPSK, 16QAM, 64QAM

Accessories Information for the host (brand name: Laerdal Medical AS, model: 204-00250)					
No.	Equipment Name	Brand Name	Model No.	Rating	Remark
1	Adapter	FSP	FSP040-RHAN3	INPUT: 100-240V, 1.5A, 50-60Hz OUTPUT: 12.0V, 3.33A, 40.0W	With power cable : Non-Shielded, 1.2m (with a ferrite core)
2	Lithium-Ion Battrey	Laerdal Medical AS	204-00350	7.34V / 5700mAh (min 5500mAh) 41Wh	External battrey

Antenna Information				
Ant.	Brand Name	Model No.	Type	Antenna Gain (dBi)
0	SAN JOSE	GEPH-057	Dipole	3.96
1	SAN JOSE	GEPH-023	Dipole	2.38

For IEEE 802.11b/g/n Mode: (2TX, 2RX)

Both Ant. 0 and Ant. 1 can be used as transmitting/receiving antennas, and they can transmit/receive signal simultaneously.

1.2. EUT Information

EUT Power Type	From Adapter / Battery			
EUT Function	<input checked="" type="checkbox"/>	Point-to-multipoint	<input type="checkbox"/>	Point-to-point
Beamforming Function	<input type="checkbox"/>	With beamforming	<input checked="" type="checkbox"/>	Without beamforming

1.3. Testing Applied Standards

According to the specifications of the manufacturer, the EUT must comply with the requirements of the following standards:

- ◆ 47 CFR FCC Part 15
- ◆ ANSI C63.10-2013

The following reference test guidance is not within the scope of accreditation of TAF:

- ◆ KDB 558074 D01 v05r02
- ◆ KDB 662911 D01 v02r01
- ◆ KDB 414788 D01 v01r01

1.4. Testing Location Information

Testing Location Information		
Test Laboratory : DEKRA Testing and Certification Co., Ltd.		
1 (TAF: 3024)	ADD: No.372-2, Sec. 4, Zhongxing Rd., Zhudong Township, Hsinchu County 31061, Taiwan, R.O.C. TEL: +886-3-582-8001 FAX: +886-3-582-8958	
2 (TAF: 3024)	ADD: No.372, Sec. 4, Zhongxing Rd., Zhudong Township, Hsinchu County 31061, Taiwan, R.O.C. TEL: +886-3-582-8001 FAX: +886-3-582-8958	
Test site number for address 1 includes HC-SR02. Test site number for address 2 includes HC-CB02, HC-CB03, HC-CB04, HC-SR10 and HC-SR12.		

Test Condition	Test Site No.	Test Engineer	Test Environment (°C / %)	Test Date
AC Conduction Emission	HC-SR02	Igor Tseng	20.2 / 57	2023/12/05
RF Conducted Emission	HC-SR12	Rueyyan Lin	21.2 / 56	2023/12/07
Radiated Emission	HC-CB02	Gary Liao	22.3~23.5 / 60~62	2023/11/14~2023/11/28

1.5. Measurement Uncertainty

Uncertainties have been calculated according to the DEKRA internal document with the emissions test results be included in the report. The measurement uncertainties given below are based on a 95% confidence level (based on a coverage factor (k=2)).

Test Item	Uncertainty
AC Power Line Conducted Emission	± 2.34 dB
Maximum Conducted Output Power	± 1.16 dB
Transmitter Radiated Spurious Emission	± 3.52 dB below 1 GHz ± 3.56 dB above 1 GHz

1.6. List of Test Equipment

HC-SR02

Instrument	Manufacturer	Model No.	Serial No.	Characteristics	Cal. Date	Next Cal. Date
Artificial Mains Network	R&S	ENV4200	848411/010	9kHz-30MHz, 4line/100A	2022/12/19	2023/12/18
EMI Test Receiver	R&S	ESR3	102608	9 kHz - 3.6 GHz	2023/09/19	2024/09/18
Two-Line V-Network	R&S	ENV216	100096	9kHz-30MHz	2023/06/02	2024/06/01
Coaxial Cable(9 m)	Harbour	RG-400	HC-SR02	9 kHz--2500 MHz	2023/08/04	2024/08/03
EMI Testing System	AUDIX	e3 210616 dekra V9	HC-SR02	N/A	N/A	N/A

HC-SR12

Instrument	Manufacturer	Model No.	Serial No.	Characteristics	Cal. Date	Next Cal. Date
High Speed Peak Power Meter Dual Input	Anritsu	ML2496A	1602004	0.3-40 GHz	2023/10/25	2024/10/24
Pulse Power Sensor	Anritsu	MA2411B	1531043	0.3-40 GHz	2023/10/25	2024/10/24
Pulse Power Sensor	Anritsu	MA2411B	1531044	0.3-40 GHz	2023/10/25	2024/10/24
Spectrum Analyzer	Keysight	N9030B	MY57140404	3 Hz-26.5 GHz	2023/04/24	2024/04/23

HC-CB02

Instrument	Manufacturer	Model No.	Serial No.	Characteristics	Cal. Date	Next Cal. Date
Signal Analyzer	R&S	FSVA40	101455	10 Hz-40 GHz	2023/10/03	2024/10/02
Trilog Broadband Antenna	Schwarzbeck	VULB 9168	1272	30 MHz-2 GHz	2023/04/13	2024/04/12
Double Ridged Horn Antenna	RF SPIN	DRH18-E	211211A18EN	1G-18GHz	2023/11/09	2024/11/08
Horn Antenna	Schwarzbeck	BBHA 9170	203	18G-40GHz	2023/02/13	2024/02/12
Pre-Amplifier	EMCI	EMC01820I	980365	30M-8 GHz,20 dB	2023/04/07	2024/04/06
Pre-Amplifier	EMEC	EM01G18GA	060741	1G-18 GHz,50 dB	2023/05/05	2024/05/04
Pre-Amplifier	DEKRA	AP-400C	201801231	18G-40 GHz,48 dB	2023/10/03	2024/10/02
EMI Test Receiver	R&S	ESR7	102260	10 Hz-7 GHz	2022/12/01	2023/11/30
Magnetic Loop Antenna	Teseq	HLA 6121	44287	0.01-30 MHz	2023/10/13	2024/10/12
Coaxial Cable(13m)	Suhner	SF104	HC-CB02	30M-18 GHz	2023/08/14	2024/08/13
Coaxial Cable(3m)	Suhner,Rosnol	SF102_UP0264	HC-CB02-1	18G-40 GHz 3 m	2023/08/14	2024/08/13
Radiated Software	AUDIX	e3 V9	HC-CB02_1	N/A	N/A	N/A

Note: All equipment upon which need to calibrated are with calibration period of 1 year.

2. Test Configuration of EUT

2.1. Test Condition

EUT Operational Condition		
Testing Voltage	Power by adapter	AC 120V/60Hz
	Power by battrey	DC 7.34V

2.2. Test Frequency Mode

Test Software Version	PUTTY v0.78
-----------------------	-------------

Modulation	Frequency (MHz)	Power Setting
802.11b	2412	15.0
	2437	15.0
	2462	15.0
802.11g	2412	12.0
	2422	18.0
	2437	19.0
	2452	16.0
	2462	12.0
802.11n (20 MHz)	2412	12.0
	2422	17.0
	2437	17.0
	2452	15.0
	2462	12.0

2.3. The Worst Case Measurement Configuration

Tests Item	AC Power Line Conducted Emission
Test Condition	AC power line conducted measurement for line and neutral
Operating Mode	Transmit
1	Power by adapter

Tests Item	Maximum Conducted Output Power
Test Condition	Conducted measurement at transmit chains

Tests Item	Transmitter Radiated Spurious Emission
Test Condition	Radiated measurement If EUT consist of multiple antenna assembly (multiple antenna are used in EUT regardless of spatial multiplexing MIMO configuration), the radiated test should be performed with highest antenna gain of each antenna type.
Operating Mode < 1GHz	Transmit
1	Power by adapter
2	Power by battrey

Mode 1 is the worst case and it was record in this test report.

Operating Mode > 1GHz	Transmit
-----------------------	----------

The EUT was performed at X axis, Y axis and Z axis position for transmitter radiated spurious emission test. The worst case was found at Y axis, so the measurement will follow this same test configuration.

Tests Item	Simultaneous Transmission Analysis - Radiated Emission Co-location
Test Condition	Radiated measurement
Operating Mode	Transmit
1	WiFi 2.4 GHz + Bluetooth
2	WiFi 5 GHz + Bluetooth

Refer to Appendix D for Radiated Emission Co-location.

Tests Item	Simultaneous Transmission Analysis - Co-location RF Exposure Evaluation
Operating Mode	Transmit
1	WiFi 2.4 GHz + Bluetooth
2	WiFi 5 GHz + Bluetooth

Mode 1 is the worst case and it was record in the RF Exposure Evaluation test report.

Refer to DEKRA Test Report No.: 23A0648R-RFUSV17S-A for Co-location RF Exposure Evaluation.

Note:

- Determining compliance shall be based on the results of the compliance measurement, not taking into account measurement instrumentation uncertainty.
- For transmitter radiated spurious emission below 1 GHz and AC power line conducted emission have performed all modes of operation were investigated and the worst-case emissions are reported.

2.4. Tested System Details

No.	Equipment	Brand Name	Model No.	Serial No.
1	NB (Notebook)	Lenovo	80T7	N/A
2	Router	ASUS	RT-AX88U	N/A

2.5. Configuration of Tested System

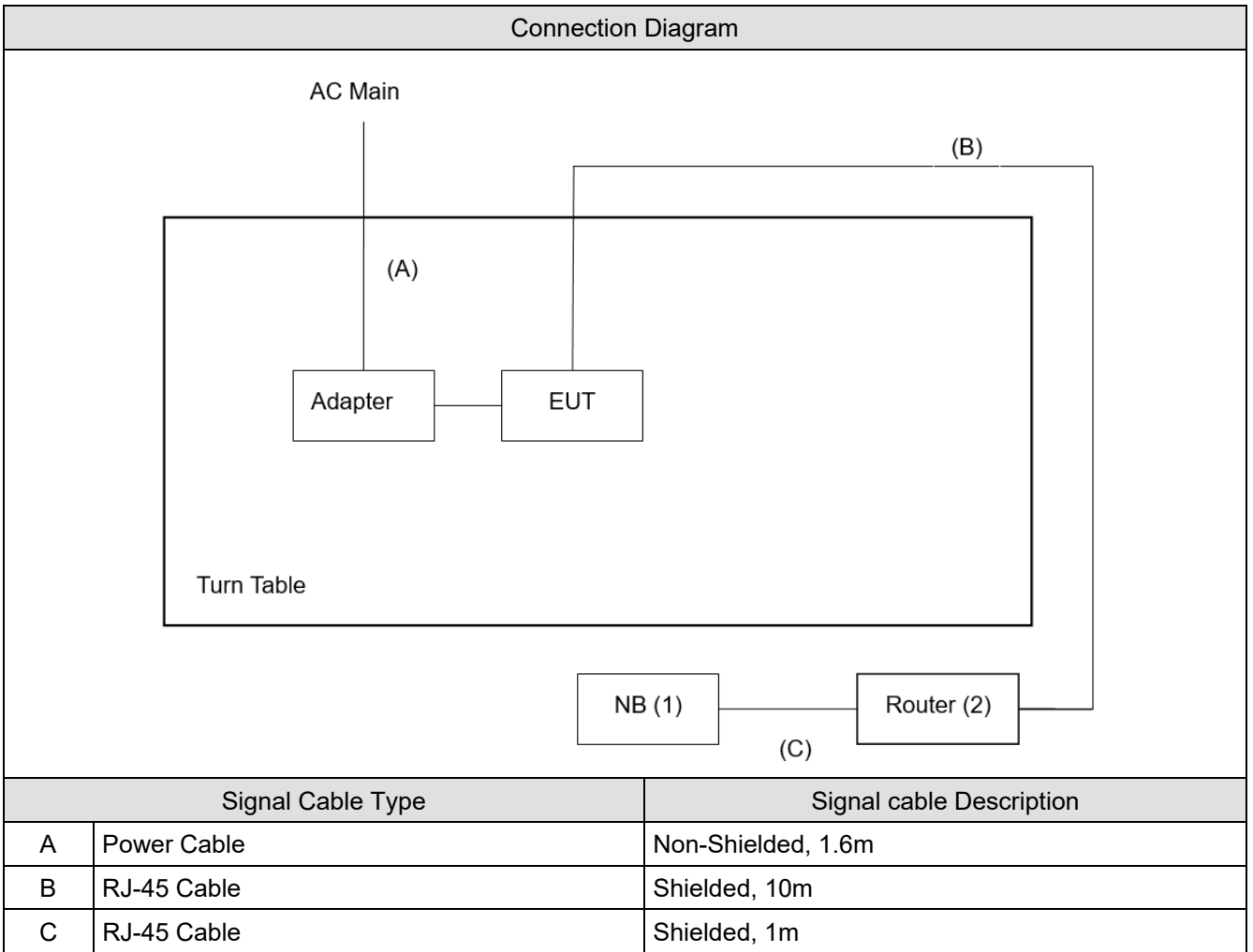

3. AC Power Line Conducted Emission

3.1. Test Setup

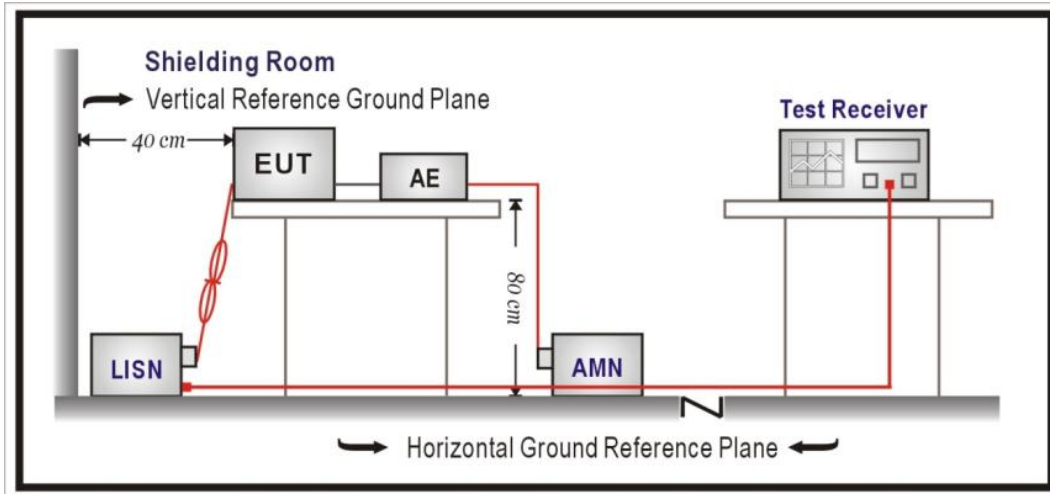

3.2. Test Limit

Frequency (MHz)	QP (dBuV)	AV (dBuV)
0.15 - 0.50	66 - 56	56 - 46
0.50 - 5.0	56	46
5.0 - 30	60	50

Remarks: In the above table, the tighter limit applies at the band edges.

3.3. Test Procedure

The EUT was setup according to ANSI C63.10: 2013. The EUT was placed on a platform of nominal size, 1 m by 1.5 m, raised 80 cm above the conducting ground plane. The vertical conducting plane was located 40 cm to the rear of the EUT. All other surfaces of EUT were at least 80 cm from any other grounded conducting surface. The EUT and simulators are connected to the main power through a line impedance stabilization network (LISN). The LISN provides a 50 ohm /50uH coupling impedance for the measuring equipment. The peripheral devices are also connected to the main power through a LISN. (Please refer to the block diagram of the test setup and photographs.)

Each current-carrying conductor of the EUT power cord, except the ground (safety) conductor, was individually connected through a LISN to the input power source.

The excess length of the power cord between the EUT and the LISN receptacle were folded back and forth at the center of the lead to form a bundle not exceeding 40 cm in length.

Conducted emissions were investigated over the frequency range from 0.15 MHz to 30 MHz using a receiver bandwidth of 9 kHz.

3.4. Test Result of AC Power Line Conducted Emission

Refer as Appendix A

4. Maximum Conducted Output Power

4.1. Test Setup

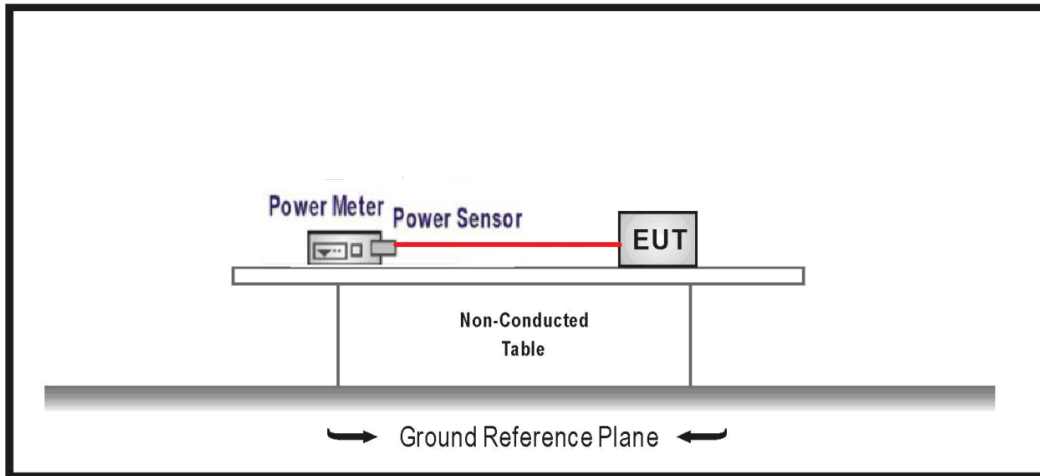

4.2. Test Limit

The maximum conducted output power shall be less 30 dBm (1 Watt).

4.3. Test Procedures

The EUT was setup according to ANSI C63.10: 2013; tested according to DTS test procedure of KDB 558074.

4.4. Test Result of Maximum Conducted Output Power

Refer as Appendix B

5. Transmitter Radiated Spurious Emission

5.1. Test Setup

9 kHz ~ 30 MHz

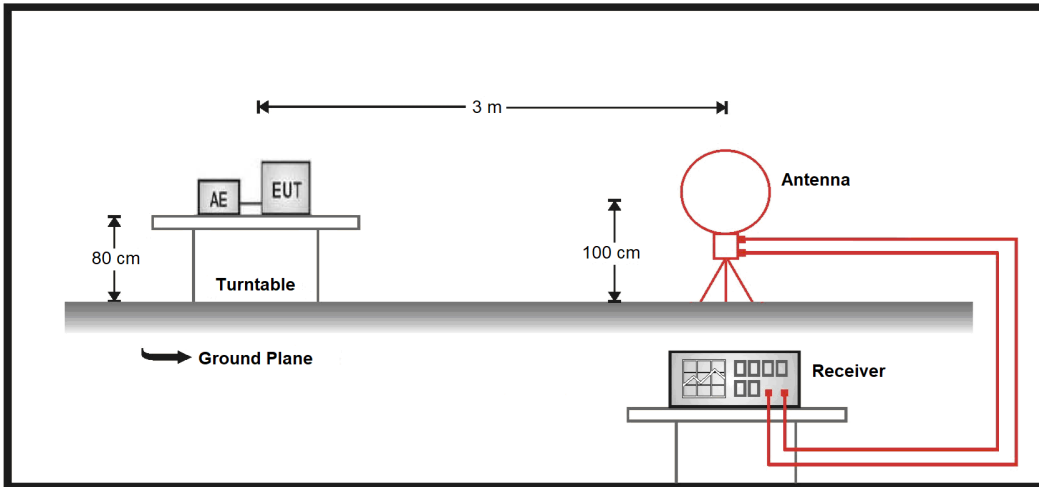

30 MHz ~ 1 GHz

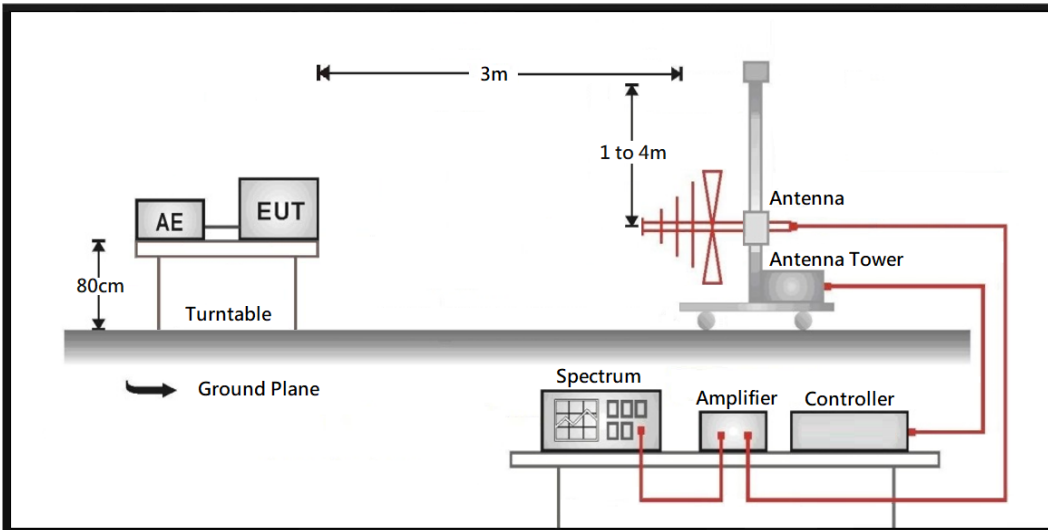

Above 1 GHz

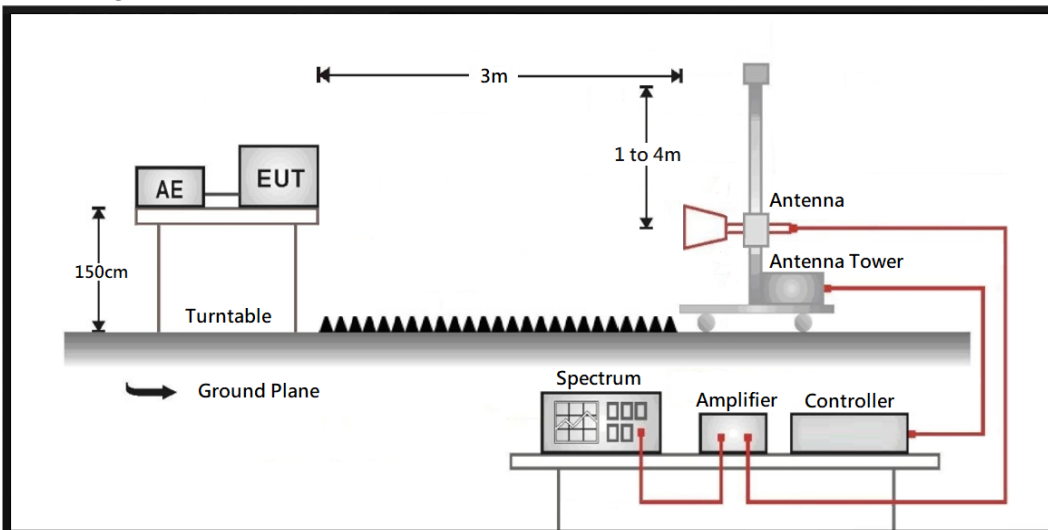

5.2. Test Limit

Frequency (MHz)	Field strength (uV/m)	Field strength (dBuV/m)	Measurement distance (m)
0.009 – 0.490	2400/F(kHz)	20 log (2400/F(kHz))	300
0.490 – 1.705	24000/F(kHz)	20 log (24000/F(kHz))	30
1.705 - 30	30	29.5	30
30 - 88	100	40	3
88 - 216	150	43.5	3
216 - 960	200	46	3
Above 960	500	54	3

Remarks:

1. Field strength (dBuV/m) = 20 log Field strength (uV/m)
2. In the Above Table, the tighter limit applies at the band edges.
3. Distance refers to the distance in meters between the measuring instrument antenna and the closed point of any part of the device or system.

5.3. Test Procedure

The EUT was setup according to ANSI C63.10: 2013 and tested according to DTS test procedure of KDB 558074.

The EUT and its simulators are placed on a turn table which is 0.8 or 1.5 meter above ground. The turn table can rotate 360 degrees to determine the position of the maximum emission level.

The antenna can move up and down between 1 meter and 4 meters to find out the maximum emission level.

Both horizontal and vertical polarization of the antenna are set on measurement. In order to find the maximum emission, all of the interface cables must be manipulated according to ANSI C63.10: 2013 on radiated measurement.

On any frequency or frequencies from 9 kHz(include The the lowest oscillator frequency generated within the device up to the 10th harmonic) to 1000 MHz, the limit shown are based on measuring equipment employing a quasi-peak detector function and on any frequency or frequencies above 1000 MHz the radiated limit shown are based upon the use of measurement instrumentation employing an average detector function. When average radiated emission measurement are included emission measurement below 1000 MHz, there also is a limit on the radio frequency emissions, as measured using instrumentation with a peak detector function, corresponding to 20 dB above the maximum permitted average limit.

The bandwidth below 1 GHz setting on the field strength meter is 120 kHz and above 1 GHz is 1 MHz.

5.4. Test Result of Transmitter Radiated Spurious Emission

Refer as Appendix C

Appendix A. Test Result of AC Power Line Conducted Emission

Test Mode	Mode 1	Phase	Line
Test Condition	802.11n (20 MHz) / Ant. 0 + Ant. 1 / 2422 MHz		

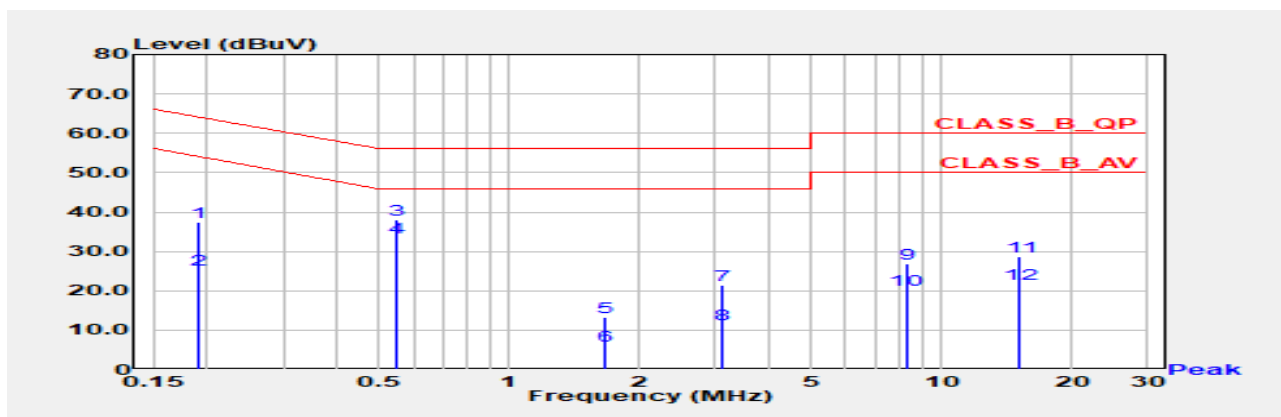

No	Frequency (MHz)	Emission Level (dBuV)	Limit (dBuV)	Margin (dB)	Reading Level (dBuV)	Correct Factor (dB)	Detector Type
1	0.190	37.46	64.01	-26.56	27.84	9.62	QP
2	0.190	25.30	54.01	-28.71	15.69	9.62	AV
3	0.546	37.91	56.00	-18.09	28.25	9.66	QP
*4	0.546	33.43	46.00	-12.57	23.78	9.66	AV
5	1.673	13.41	56.00	-42.59	3.68	9.73	QP
6	1.673	6.09	46.00	-39.91	-3.65	9.73	AV
7	3.122	21.58	56.00	-34.42	11.78	9.80	QP
8	3.122	11.37	46.00	-34.63	1.57	9.80	AV
9	8.275	26.74	60.00	-33.26	16.72	10.02	QP
10	8.275	20.21	50.00	-29.79	10.19	10.02	AV
11	15.191	28.73	60.00	-31.27	18.49	10.23	QP
12	15.191	21.82	50.00	-28.18	11.59	10.23	AV

Note:

1. All Reading Levels are Quasi-Peak and average value.
2. " * ", means this data is the worst emission level.
3. Measurement Level = Reading Level + Correct Factor.

Test Mode	Mode 1	Phase	Neutral
Test Condition	802.11n (20 MHz) / Ant. 0 + Ant. 1 / 2422 MHz		

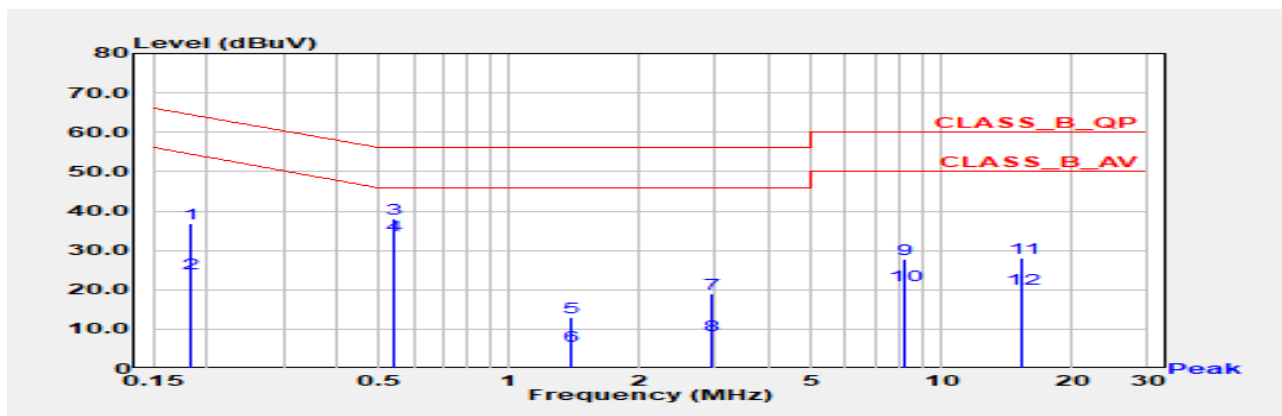

No	Frequency (MHz)	Emission Level (dBuV)	Limit (dBuV)	Margin (dB)	Reading Level (dBuV)	Correct Factor (dB)	Detector Type
1	0.184	36.81	64.31	-27.51	27.19	9.62	QP
2	0.184	24.27	54.31	-30.05	14.65	9.62	AV
3	0.544	37.91	56.00	-18.09	28.27	9.65	QP
*4	0.544	33.75	46.00	-12.25	24.11	9.65	AV
5	1.396	12.95	56.00	-43.05	3.23	9.72	QP
6	1.396	5.59	46.00	-40.41	-4.13	9.72	AV
7	2.926	19.14	56.00	-36.86	9.35	9.80	QP
8	2.926	8.31	46.00	-37.69	-1.49	9.80	AV
9	8.236	27.90	60.00	-32.10	17.86	10.04	QP
10	8.236	21.06	50.00	-28.94	11.02	10.04	AV
11	15.389	28.02	60.00	-31.98	17.66	10.35	QP
12	15.389	20.25	50.00	-29.75	9.90	10.35	AV

Note:

1. All Reading Levels are Quasi-Peak and average value.
2. " * ", means this data is the worst emission level.
3. Measurement Level = Reading Level + Correct Factor.

Appendix B. Test Result of Maximum Conducted Output Power

Modulation	Frequency (MHz)	Maximum Conducted Average Output Power (dBm)				Antenna Gain (dBi)	E.I.R.P Power (dBm)	E.I.R.P Limit (dBm)
		Ant. 0	Ant. 1	Total	Limit			
802.11b	2412	14.41	14.17	17.30	30.00	3.96	21.26	36.00
	2437	14.65	14.86	17.77	30.00	3.96	21.73	36.00
	2462	14.84	14.68	17.77	30.00	3.96	21.73	36.00
802.11g	2412	11.37	11.14	14.27	30.00	3.96	18.23	36.00
	2422	17.23	16.91	20.08	30.00	3.96	24.04	36.00
	2437	18.06	18.19	21.14	30.00	3.96	25.10	36.00
	2452	15.31	15.26	18.30	30.00	3.96	22.26	36.00
	2462	11.69	11.51	14.61	30.00	3.96	18.57	36.00
802.11n (20 MHz)	2412	11.46	11.20	14.34	30.00	3.96	18.30	36.00
	2422	16.31	16.13	19.23	30.00	3.96	23.19	36.00
	2437	16.41	16.24	19.34	30.00	3.96	23.30	36.00
	2452	14.57	14.49	17.54	30.00	3.96	21.50	36.00
	2462	11.87	11.60	14.75	30.00	3.96	18.71	36.00

Note: E.I.R.P. = Maximum Conducted Output Power + Antenna Gain.

Appendix C. Test Result of Transmitter Radiated Spurious Emission

30 MHz ~ 1 GHz

Test Mode: Mode 1

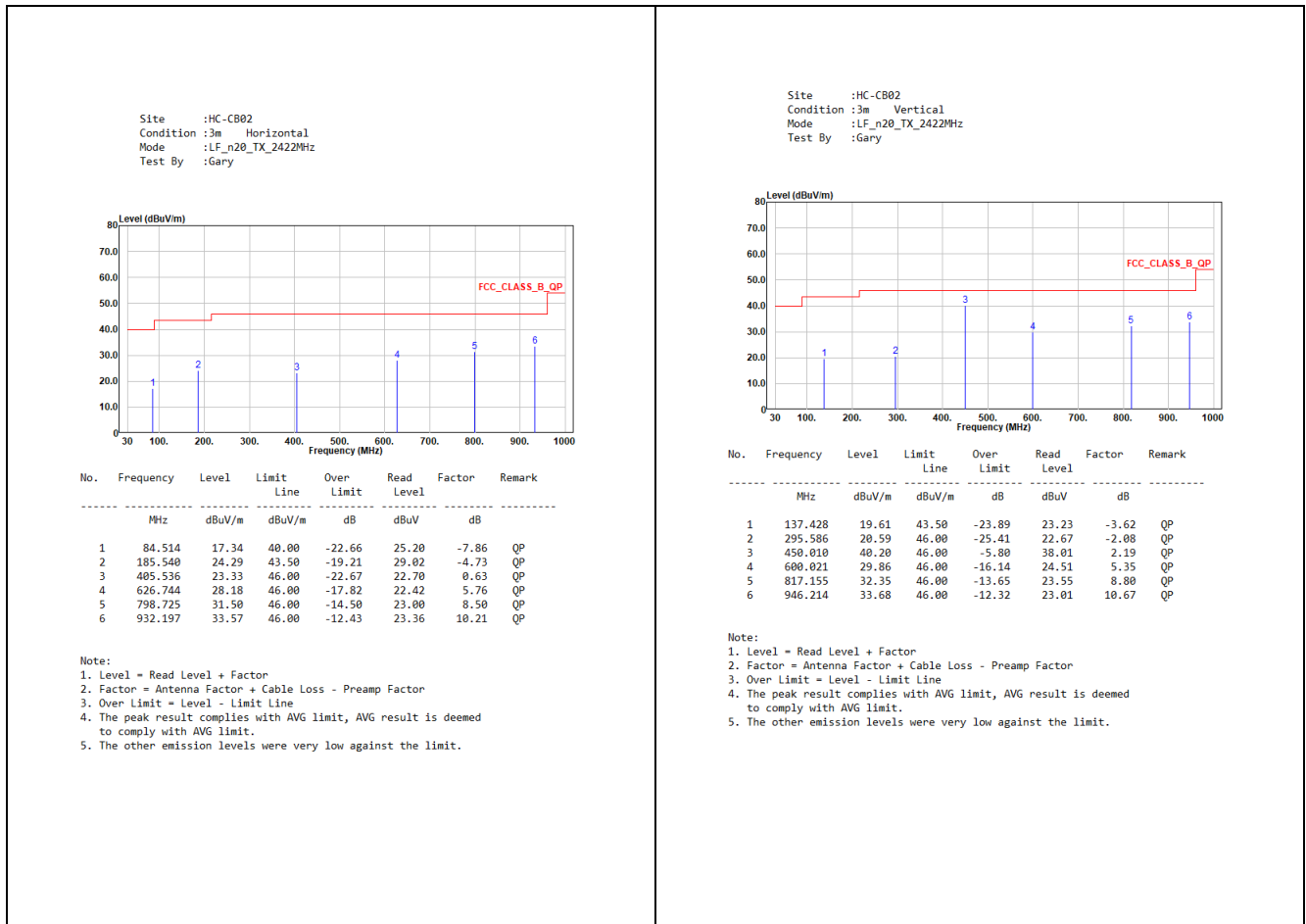

Above 1 GHz

Site :HC-C802
 Condition :3m Horizontal
 Mode :b_TX_2412MHz
 Test By :Gary

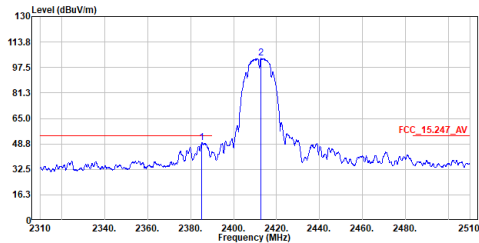

No.	Frequency	Level	Limit	Over	Read	Factor	Remark
	MHz	dBuV/m	dBuV/m	dB	dBuV	dB	
1	2385.200	49.33	54.00	-4.67	37.45	11.88	Average
2	2412.800	103.28	-----	-----	91.25	12.03	Average

Note:
 1. Level = Read Level + Factor
 2. Factor = Antenna Factor + Cable Loss - Preamp Factor
 3. Over Limit = Level - Limit Line
 4. The peak result complies with AVG limit, AVG result is deemed to comply with AVG limit.
 5. The other emission levels were very low against the limit.

Site :HC-C802
 Condition :3m Horizontal
 Mode :b_TX_2412MHz
 Test By :Gary

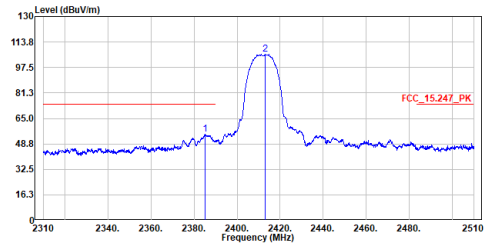

No.	Frequency	Level	Limit	Over	Read	Factor	Remark
	MHz	dBuV/m	dBuV/m	dB	dBuV	dB	
1	2385.200	54.82	74.00	-19.18	42.94	11.88	Peak
2	2413.000	105.78	-----	-----	93.75	12.03	Peak

Note:
 1. Level = Read Level + Factor
 2. Factor = Antenna Factor + Cable Loss - Preamp Factor
 3. Over Limit = Level - Limit Line
 4. The peak result complies with AVG limit, AVG result is deemed to comply with AVG limit.
 5. The other emission levels were very low against the limit.

Site :HC-C802
 Condition :3m Vertical
 Mode :b_TX_2412MHz
 Test By :Gary

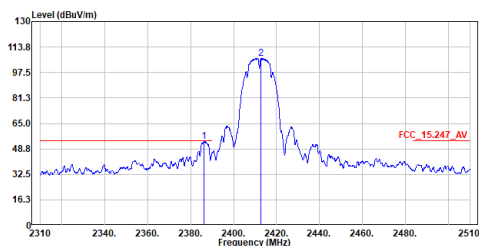

No.	Frequency	Level	Limit	Over	Read	Factor	Remark
	MHz	dBuV/m	dBuV/m	dB	dBuV	dB	
1	2386.300	53.65	54.00	-0.35	41.76	11.89	Average
2	2412.800	106.57	-----	-----	94.54	12.03	Average

Note:
 1. Level = Read Level + Factor
 2. Factor = Antenna Factor + Cable Loss - Preamp Factor
 3. Over Limit = Level - Limit Line
 4. The peak result complies with AVG limit, AVG result is deemed to comply with AVG limit.
 5. The other emission levels were very low against the limit.

Site :HC-C802
 Condition :3m Vertical
 Mode :b_TX_2412MHz
 Test By :Gary

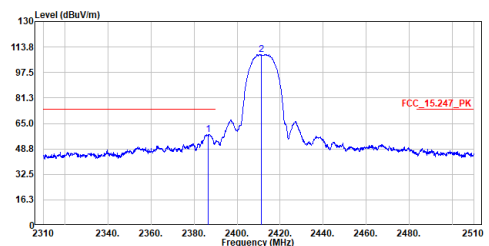

No.	Frequency	Level	Limit	Over	Read	Factor	Remark
	MHz	dBuV/m	dBuV/m	dB	dBuV	dB	
1	2386.600	58.04	74.00	-15.96	46.15	11.89	Peak
2	2411.200	109.05	-----	-----	97.03	12.02	Peak

Note:
 1. Level = Read Level + Factor
 2. Factor = Antenna Factor + Cable Loss - Preamp Factor
 3. Over Limit = Level - Limit Line
 4. The peak result complies with AVG limit, AVG result is deemed to comply with AVG limit.
 5. The other emission levels were very low against the limit.

Site :HC-CB02
 Condition :3m Horizontal
 Mode :b_TX_2412MHz
 Test By :Gary

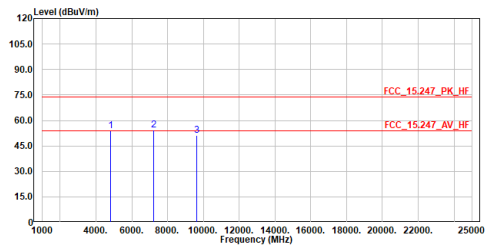

No.	Frequency MHz	Level dBuV/m	Limit Line dBuV/m	Over Limit dB	Read Level dBuV	Factor dB	Remark
1	4824.000	53.77	74.00	-20.23	68.45	-14.68	Peak
2	7236.000	54.49	74.00	-19.51	62.44	-7.95	Peak
3	9648.000	51.25	74.00	-22.75	55.73	-4.48	Peak

Note:
 1. Level = Read Level + Factor
 2. Factor = Antenna Factor + Cable Loss - Preamp Factor
 3. Over Limit = Level - Limit Line
 4. The peak result complies with AVG limit, AVG result is deemed to comply with AVG limit.
 5. The other emission levels were very low against the limit.

Site :HC-CB02
 Condition :3m Vertical
 Mode :b_TX_2412MHz
 Test By :Gary

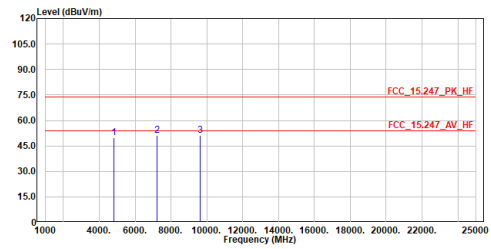

No.	Frequency MHz	Level dBuV/m	Limit Line dBuV/m	Over Limit dB	Read Level dBuV	Factor dB	Remark
1	4824.000	49.97	74.00	-24.03	64.65	-14.68	Peak
2	7236.000	51.32	74.00	-22.68	59.27	-7.95	Peak
3	9648.000	51.03	74.00	-22.97	55.51	-4.48	Peak

Note:
 1. Level = Read Level + Factor
 2. Factor = Antenna Factor + Cable Loss - Preamp Factor
 3. Over Limit = Level - Limit Line
 4. The peak result complies with AVG limit, AVG result is deemed to comply with AVG limit.
 5. The other emission levels were very low against the limit.

Site :HC-CB02
 Condition :3m Horizontal
 Mode :b_TX_2437MHz
 Test By :Gary

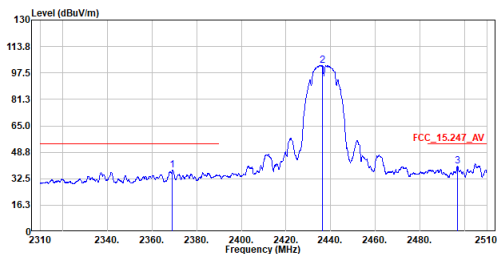

No.	Frequency MHz	Level dBuV/m	Limit Line dBuV/m	Over Limit dB	Read Level dBuV	Factor dB	Remark
1	2369.100	37.84	54.00	-16.16	26.04	11.80	Average
2	2436.300	102.15	-----	-----	90.00	12.15	Average
3	2496.700	40.15	54.00	-13.85	27.68	12.47	Average

Note:
 1. Level = Read Level + Factor
 2. Factor = Antenna Factor + Cable Loss - Preamp Factor
 3. Over Limit = Level - Limit Line
 4. The peak result complies with AVG limit, AVG result is deemed to comply with AVG limit.
 5. The other emission levels were very low against the limit.

Site :HC-CB02
 Condition :3m Horizontal
 Mode :b_TX_2437MHz
 Test By :Gary

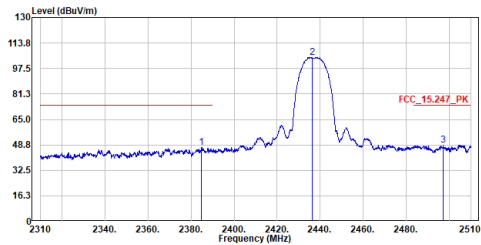

No.	Frequency MHz	Level dBuV/m	Limit Line dBuV/m	Over Limit dB	Read Level dBuV	Factor dB	Remark
1	2384.900	47.19	74.00	-26.81	35.31	11.88	Peak
2	2436.200	104.70	-----	-----	92.55	12.15	Peak
3	2497.100	48.35	74.00	-25.65	35.88	12.47	Peak

Note:
 1. Level = Read Level + Factor
 2. Factor = Antenna Factor + Cable Loss - Preamp Factor
 3. Over Limit = Level - Limit Line
 4. The peak result complies with AVG limit, AVG result is deemed to comply with AVG limit.
 5. The other emission levels were very low against the limit.

Site :HC-C802
 Condition :3m Vertical
 Mode :b_TX_2437MHz
 Test By :Gary

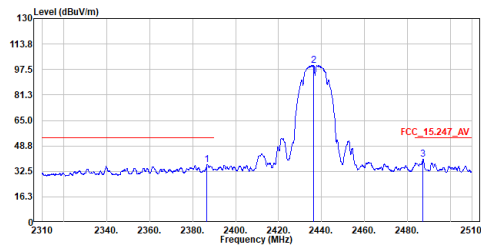

No.	Frequency MHz	Level dBuV/m	Limit Line dBuV/m	Over Limit dB	Read Level dBuV	Factor dB	Remark
1	2386.700	36.93	54.00	-17.07	25.04	11.89	Average
2	2436.300	100.16	-----	-----	88.01	12.15	Average
3	2487.300	40.21	54.00	-13.79	27.79	12.42	Average

Note:
 1. Level = Read Level + Factor
 2. Factor = Antenna Factor + Cable Loss - Preamp Factor
 3. Over Limit = Level - Limit Line
 4. The peak result complies with AVG limit, AVG result is deemed to comply with AVG limit.
 5. The other emission levels were very low against the limit.

Site :HC-C802
 Condition :3m Vertical
 Mode :b_TX_2437MHz
 Test By :Gary

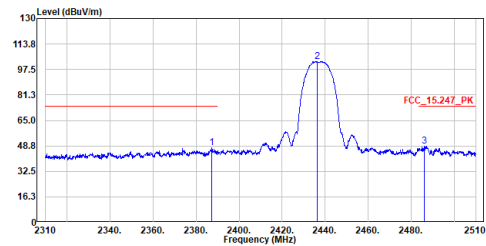

No.	Frequency MHz	Level dBuV/m	Limit Line dBuV/m	Over Limit dB	Read Level dBuV	Factor dB	Remark
1	2387.400	47.55	74.00	-26.45	35.66	11.89	Peak
2	2436.200	102.70	-----	-----	90.55	12.15	Peak
3	2486.100	48.44	74.00	-25.56	36.03	12.41	Peak

Note:
 1. Level = Read Level + Factor
 2. Factor = Antenna Factor + Cable Loss - Preamp Factor
 3. Over Limit = Level - Limit Line
 4. The peak result complies with AVG limit, AVG result is deemed to comply with AVG limit.
 5. The other emission levels were very low against the limit.

Site :HC-C802
 Condition :3m Horizontal
 Mode :b_TX_2437MHz
 Test By :Gary

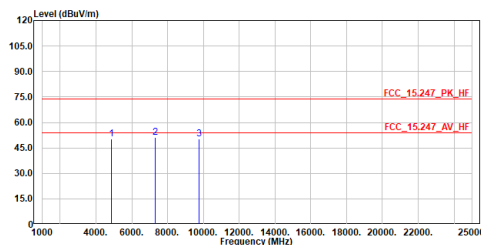

No.	Frequency MHz	Level dBuV/m	Limit Line dBuV/m	Over Limit dB	Read Level dBuV	Factor dB	Remark
1	4874.000	50.06	74.00	-23.94	64.54	-14.48	Peak
2	7311.000	51.07	74.00	-22.93	58.95	-7.88	Peak
3	9748.000	50.44	74.00	-23.56	54.72	-4.28	Peak

Note:
 1. Level = Read Level + Factor
 2. Factor = Antenna Factor + Cable Loss - Preamp Factor
 3. Over Limit = Level - Limit Line
 4. The peak result complies with AVG limit, AVG result is deemed to comply with AVG limit.
 5. The other emission levels were very low against the limit.

Site :HC-C802
 Condition :3m Vertical
 Mode :b_TX_2437MHz
 Test By :Gary

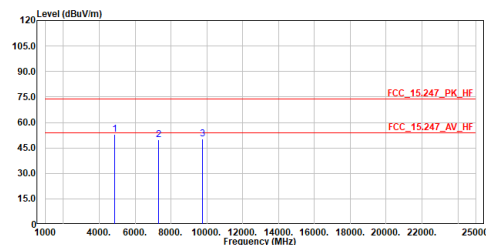

No.	Frequency MHz	Level dBuV/m	Limit Line dBuV/m	Over Limit dB	Read Level dBuV	Factor dB	Remark
1	4874.000	52.86	74.00	-21.14	67.34	-14.48	Peak
2	7311.000	49.98	74.00	-24.02	57.86	-7.88	Peak
3	9748.000	50.41	74.00	-23.59	54.69	-4.28	Peak

Note:
 1. Level = Read Level + Factor
 2. Factor = Antenna Factor + Cable Loss - Preamp Factor
 3. Over Limit = Level - Limit Line
 4. The peak result complies with AVG limit, AVG result is deemed to comply with AVG limit.
 5. The other emission levels were very low against the limit.

Site :HC-CB02
 Condition :3m Horizontal
 Mode :b_TX_2462MHz
 Test By :Gary

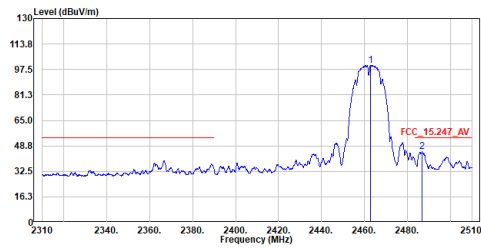

No.	Frequency MHz	Level dBuV/m	Limit Line dBuV/m	Over Limit dB	Read Level dBuV	Factor dB	Remark
1	2462.800	100.11	-----	-----	87.81	12.30	Average
2	2486.800	44.92	54.00	-9.08	32.50	12.42	Average

Note:
 1. Level = Read Level + Factor
 2. Factor = Antenna Factor + Cable Loss - Preamp Factor
 3. Over Limit = Level - Limit Line
 4. The peak result complies with AVG limit, AVG result is deemed to comply with AVG limit.
 5. The other emission levels were very low against the limit.

Site :HC-CB02
 Condition :3m Horizontal
 Mode :b_TX_2462MHz
 Test By :Gary

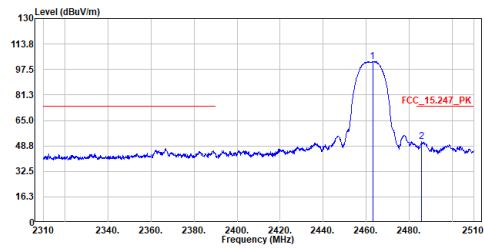

No.	Frequency MHz	Level dBuV/m	Limit Line dBuV/m	Over Limit dB	Read Level dBuV	Factor dB	Remark
1	2463.000	102.67	-----	-----	90.37	12.30	Peak
2	2485.700	51.30	74.00	-22.70	38.89	12.41	Peak

Note:
 1. Level = Read Level + Factor
 2. Factor = Antenna Factor + Cable Loss - Preamp Factor
 3. Over Limit = Level - Limit Line
 4. The peak result complies with AVG limit, AVG result is deemed to comply with AVG limit.
 5. The other emission levels were very low against the limit.

Site :HC-CB02
 Condition :3m Vertical
 Mode :b_TX_2462MHz
 Test By :Gary

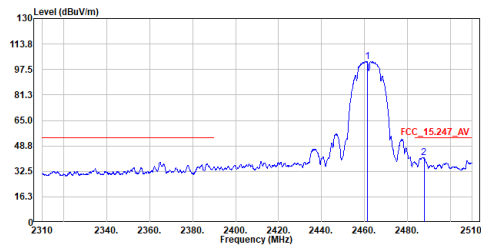

No.	Frequency MHz	Level dBuV/m	Limit Line dBuV/m	Over Limit dB	Read Level dBuV	Factor dB	Remark
1	2461.300	102.57	-----	-----	90.28	12.29	Average
2	2487.700	41.39	54.00	-12.61	28.96	12.43	Average

Note:
 1. Level = Read Level + Factor
 2. Factor = Antenna Factor + Cable Loss - Preamp Factor
 3. Over Limit = Level - Limit Line
 4. The peak result complies with AVG limit, AVG result is deemed to comply with AVG limit.
 5. The other emission levels were very low against the limit.

Site :HC-CB02
 Condition :3m Vertical
 Mode :b_TX_2462MHz
 Test By :Gary

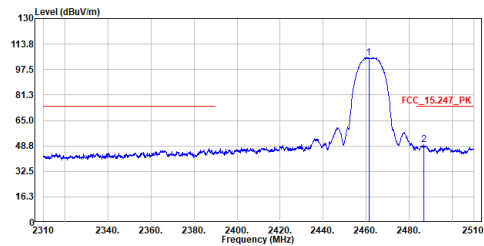

No.	Frequency MHz	Level dBuV/m	Limit Line dBuV/m	Over Limit dB	Read Level dBuV	Factor dB	Remark
1	2461.200	105.12	-----	-----	92.83	12.29	Peak
2	2486.700	49.49	74.00	-24.51	37.07	12.42	Peak

Note:
 1. Level = Read Level + Factor
 2. Factor = Antenna Factor + Cable Loss - Preamp Factor
 3. Over Limit = Level - Limit Line
 4. The peak result complies with AVG limit, AVG result is deemed to comply with AVG limit.
 5. The other emission levels were very low against the limit.

Site :HC-C802
 Condition :3m Horizontal
 Mode :b_TX_2462MHz
 Test By :Gary

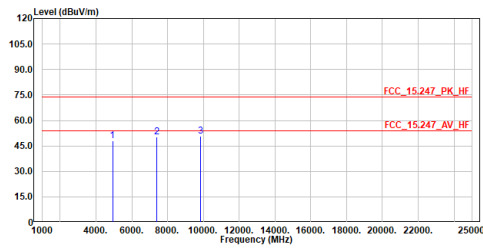

No.	Frequency MHz	Level dBuV/m	Limit dBuV/m	Over Limit dB	Read Level dBuV	Factor dB	Remark
1	4924.000	47.96	74.00	-26.04	62.24	-14.28	Peak
2	7386.000	50.19	74.00	-23.81	57.98	-7.79	Peak
3	9848.000	50.87	74.00	-23.13	54.95	-4.08	Peak

Note:
 1. Level = Read Level + Factor
 2. Factor = Antenna Factor + Cable Loss - Preamp Factor
 3. Over Limit = Level - Limit Line
 4. The peak result complies with AVG limit, AVG result is deemed to comply with AVG limit.
 5. The other emission levels were very low against the limit.

Site :HC-C802
 Condition :3m Vertical
 Mode :b_TX_2462MHz
 Test By :Gary

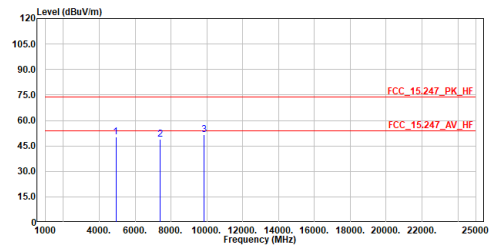

No.	Frequency MHz	Level dBuV/m	Limit dBuV/m	Over Limit dB	Read Level dBuV	Factor dB	Remark
1	4924.000	50.09	74.00	-23.91	64.37	-14.28	Peak
2	7386.000	49.05	74.00	-24.95	56.84	-7.79	Peak
3	9848.000	51.62	74.00	-22.38	55.70	-4.08	Peak

Note:
 1. Level = Read Level + Factor
 2. Factor = Antenna Factor + Cable Loss - Preamp Factor
 3. Over Limit = Level - Limit Line
 4. The peak result complies with AVG limit, AVG result is deemed to comply with AVG limit.
 5. The other emission levels were very low against the limit.

Site :HC-C802
 Condition :3m Horizontal
 Mode :g_TX_2412MHz
 Test By :Gary

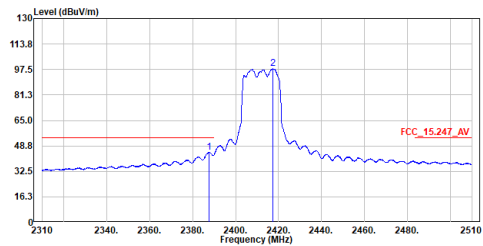

No.	Frequency MHz	Level dBuV/m	Limit dBuV/m	Over Limit dB	Read Level dBuV	Factor dB	Remark
1	2387.800	44.84	54.00	-9.16	32.94	11.90	Average
2	2417.300	98.05	-----	-----	86.00	12.05	Average

Note:
 1. Level = Read Level + Factor
 2. Factor = Antenna Factor + Cable Loss - Preamp Factor
 3. Over Limit = Level - Limit Line
 4. The peak result complies with AVG limit, AVG result is deemed to comply with AVG limit.
 5. The other emission levels were very low against the limit.

Site :HC-C802
 Condition :3m Horizontal
 Mode :g_TX_2412MHz
 Test By :Gary

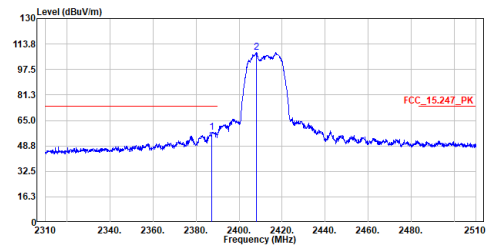

No.	Frequency MHz	Level dBuV/m	Limit dBuV/m	Over Limit dB	Read Level dBuV	Factor dB	Remark
1	2387.200	57.55	74.00	-16.45	45.66	11.89	Peak
2	2408.000	108.20	-----	-----	96.19	12.01	Peak

Note:
 1. Level = Read Level + Factor
 2. Factor = Antenna Factor + Cable Loss - Preamp Factor
 3. Over Limit = Level - Limit Line
 4. The peak result complies with AVG limit, AVG result is deemed to comply with AVG limit.
 5. The other emission levels were very low against the limit.

Site :HC-CB02
 Condition :3m Vertical
 Mode :g_TX_2412MHz
 Test By :Gary

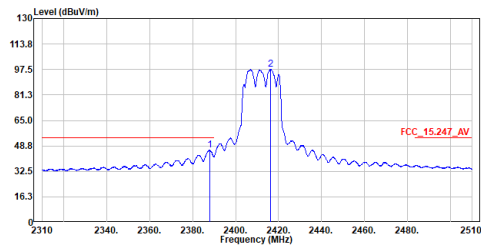

No.	Frequency MHz	Level dBuV/m	Limit Line dBuV/m	Over Limit dB	Read Level dBuV	Factor dB	Remark
1	2388.000	45.95	54.00	-8.05	34.05	11.90	Average
2	2416.300	97.73	-----	-----	85.68	12.05	Average

Note:
 1. Level = Read Level + Factor
 2. Factor = Antenna Factor + Cable Loss - Preamp Factor
 3. Over Limit = Level - Limit Line
 4. The peak result complies with AVG limit, AVG result is deemed to comply with AVG limit.
 5. The other emission levels were very low against the limit.

Site :HC-CB02
 Condition :3m Vertical
 Mode :g_TX_2412MHz
 Test By :Gary

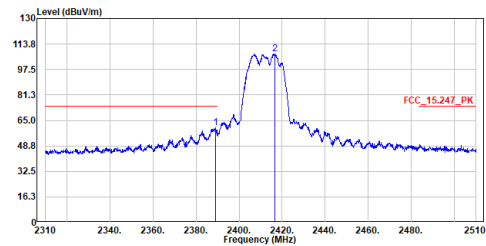

No.	Frequency MHz	Level dBuV/m	Limit Line dBuV/m	Over Limit dB	Read Level dBuV	Factor dB	Remark
1	2389.000	60.52	74.00	-13.48	48.61	11.91	Peak
2	2416.600	107.58	-----	-----	95.53	12.05	Peak

Note:
 1. Level = Read Level + Factor
 2. Factor = Antenna Factor + Cable Loss - Preamp Factor
 3. Over Limit = Level - Limit Line
 4. The peak result complies with AVG limit, AVG result is deemed to comply with AVG limit.
 5. The other emission levels were very low against the limit.

Site :HC-CB02
 Condition :3m Horizontal
 Mode :g_TX_2412MHz
 Test By :Gary

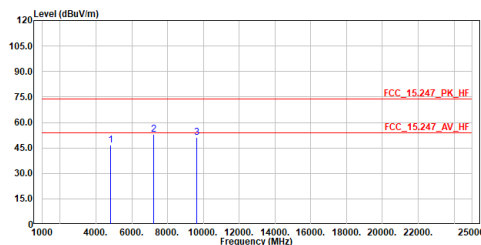

No.	Frequency MHz	Level dBuV/m	Limit Line dBuV/m	Over Limit dB	Read Level dBuV	Factor dB	Remark
1	4824.000	46.74	74.00	-27.26	61.42	-14.68	Peak
2	7236.000	53.02	74.00	-20.98	60.97	-7.95	Peak
3	9648.000	51.22	74.00	-22.78	55.70	-4.48	Peak

Note:
 1. Level = Read Level + Factor
 2. Factor = Antenna Factor + Cable Loss - Preamp Factor
 3. Over Limit = Level - Limit Line
 4. The peak result complies with AVG limit, AVG result is deemed to comply with AVG limit.
 5. The other emission levels were very low against the limit.

Site :HC-CB02
 Condition :3m Vertical
 Mode :g_TX_2412MHz
 Test By :Gary

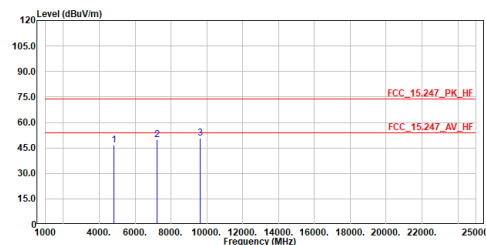

No.	Frequency MHz	Level dBuV/m	Limit Line dBuV/m	Over Limit dB	Read Level dBuV	Factor dB	Remark
1	4824.000	46.49	74.00	-27.51	61.17	-14.68	Peak
2	7236.000	49.97	74.00	-24.03	57.92	-7.95	Peak
3	9648.000	50.77	74.00	-23.23	55.25	-4.48	Peak

Note:
 1. Level = Read Level + Factor
 2. Factor = Antenna Factor + Cable Loss - Preamp Factor
 3. Over Limit = Level - Limit Line
 4. The peak result complies with AVG limit, AVG result is deemed to comply with AVG limit.
 5. The other emission levels were very low against the limit.

Site :HC-CB02
 Condition :3m Horizontal
 Mode :g_TX_2422MHz
 Test By :Gary

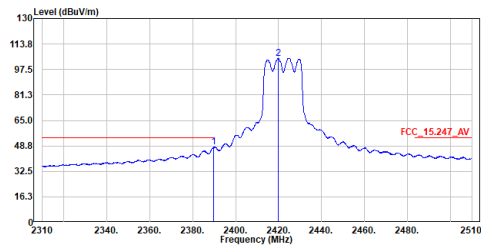

No.	Frequency MHz	Level dBuV/m	Limit dBuV/m	Over Limit dB	Read Level dBuV	Factor dB	Remark
1	2389.800	47.85	54.00	-6.15	35.94	11.91	Average
2	2419.900	104.69	-----	-----	92.62	12.07	Average

Note:
 1. Level = Read Level + Factor
 2. Factor = Antenna Factor + Cable Loss - Preamp Factor
 3. Over Limit = Level - Limit Line
 4. The peak result complies with AVG limit, AVG result is deemed to comply with AVG limit.
 5. The other emission levels were very low against the limit.

Site :HC-CB02
 Condition :3m Horizontal
 Mode :g_TX_2422MHz
 Test By :Gary

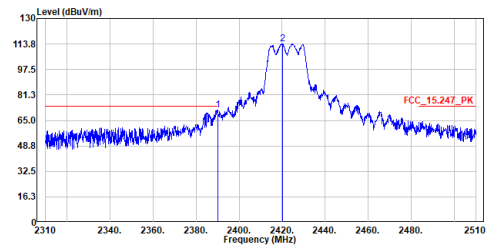

No.	Frequency MHz	Level dBuV/m	Limit dBuV/m	Over Limit dB	Read Level dBuV	Factor dB	Remark
1	2390.000	71.49	74.00	-2.51	59.58	11.91	Peak
2	2420.300	113.83	-----	-----	101.76	12.07	Peak

Note:
 1. Level = Read Level + Factor
 2. Factor = Antenna Factor + Cable Loss - Preamp Factor
 3. Over Limit = Level - Limit Line
 4. The peak result complies with AVG limit, AVG result is deemed to comply with AVG limit.
 5. The other emission levels were very low against the limit.

Site :HC-CB02
 Condition :3m Vertical
 Mode :g_TX_2422MHz
 Test By :Gary

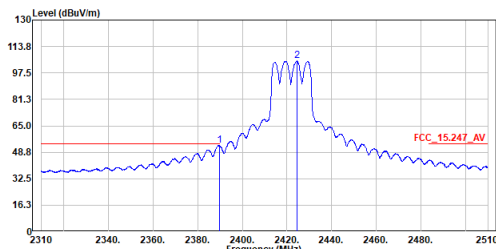

No.	Frequency MHz	Level dBuV/m	Limit dBuV/m	Over Limit dB	Read Level dBuV	Factor dB	Remark
1	2389.700	52.82	54.00	-1.18	40.91	11.91	Average
2	2424.400	104.76	-----	-----	92.66	12.10	Average

Note:
 1. Level = Read Level + Factor
 2. Factor = Antenna Factor + Cable Loss - Preamp Factor
 3. Over Limit = Level - Limit Line
 4. The peak result complies with AVG limit, AVG result is deemed to comply with AVG limit.
 5. The other emission levels were very low against the limit.

Site :HC-CB02
 Condition :3m Vertical
 Mode :g_TX_2422MHz
 Test By :Gary

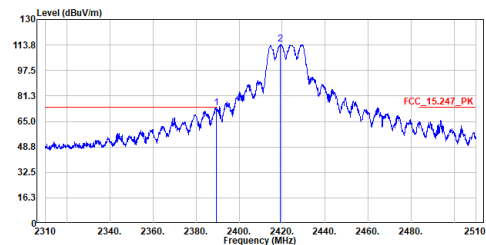

No.	Frequency MHz	Level dBuV/m	Limit dBuV/m	Over Limit dB	Read Level dBuV	Factor dB	Remark
1	2389.300	73.80	74.00	-0.20	61.89	11.91	Peak
2	2419.300	114.17	-----	-----	102.10	12.07	Peak

Note:
 1. Level = Read Level + Factor
 2. Factor = Antenna Factor + Cable Loss - Preamp Factor
 3. Over Limit = Level - Limit Line
 4. The peak result complies with AVG limit, AVG result is deemed to comply with AVG limit.
 5. The other emission levels were very low against the limit.

Site :HC-CB02
 Condition :3m Horizontal
 Mode :g_TX_2422MHz
 Test By :Gary

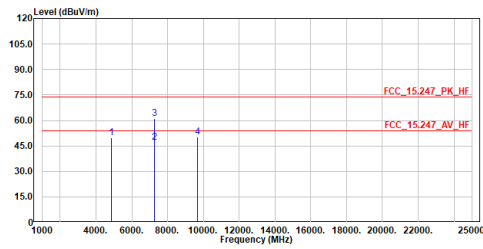

No.	Frequency	Level	Limit	Over	Read	Factor	Remark
	MHz	dBuV/m	dBuV/m	dB	dBuV	dB	
1	4844.000	49.85	74.00	-24.15	64.45	-14.60	Peak
2	7266.000	46.88	54.00	-7.12	54.81	-7.93	Average
3	7266.000	61.26	74.00	-12.74	69.19	-7.93	Peak
4	9688.000	50.41	74.00	-23.59	54.81	-4.40	Peak

Note:
 1. Level = Read Level + Factor
 2. Factor = Antenna Factor + Cable Loss - Preamp Factor
 3. Over Limit = Level - Limit Line
 4. The peak result complies with AVG limit, AVG result is deemed to comply with AVG limit.
 5. The other emission levels were very low against the limit.

Site :HC-CB02
 Condition :3m Vertical
 Mode :g_TX_2422MHz
 Test By :Gary

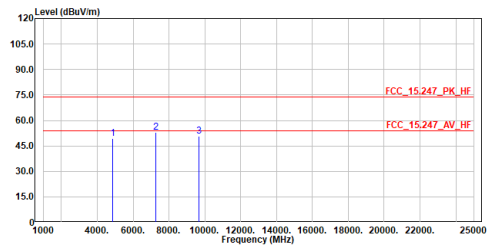

No.	Frequency	Level	Limit	Over	Read	Factor	Remark
	MHz	dBuV/m	dBuV/m	dB	dBuV	dB	
1	4844.000	49.47	74.00	-24.53	64.07	-14.60	Peak
2	7266.000	52.89	74.00	-21.11	60.82	-7.93	Peak
3	9688.000	50.60	74.00	-23.40	55.00	-4.40	Peak

Note:
 1. Level = Read Level + Factor
 2. Factor = Antenna Factor + Cable Loss - Preamp Factor
 3. Over Limit = Level - Limit Line
 4. The peak result complies with AVG limit, AVG result is deemed to comply with AVG limit.
 5. The other emission levels were very low against the limit.

Site :HC-CB02
 Condition :3m Horizontal
 Mode :g_TX_2437MHz
 Test By :Gary

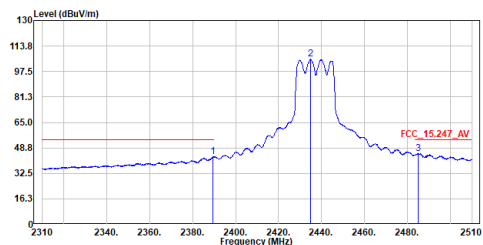

No.	Frequency	Level	Limit	Over	Read	Factor	Remark
	MHz	dBuV/m	dBuV/m	dB	dBuV	dB	
1	2389.500	42.95	54.00	-11.05	31.04	11.91	Average
2	2434.900	105.27	-----	-----	93.12	12.15	Average
3	2485.100	45.24	54.00	-8.76	32.83	12.41	Average

Note:
 1. Level = Read Level + Factor
 2. Factor = Antenna Factor + Cable Loss - Preamp Factor
 3. Over Limit = Level - Limit Line
 4. The peak result complies with AVG limit, AVG result is deemed to comply with AVG limit.
 5. The other emission levels were very low against the limit.

Site :HC-CB02
 Condition :3m Horizontal
 Mode :g_TX_2437MHz
 Test By :Gary

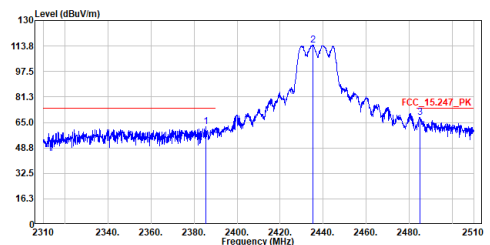

No.	Frequency	Level	Limit	Over	Read	Factor	Remark
	MHz	dBuV/m	dBuV/m	dB	dBuV	dB	
1	2385.400	62.12	74.00	-11.88	50.24	11.88	Peak
2	2435.300	114.50	-----	-----	102.35	12.15	Peak
3	2485.100	68.21	74.00	-5.79	55.80	12.41	Peak

Note:
 1. Level = Read Level + Factor
 2. Factor = Antenna Factor + Cable Loss - Preamp Factor
 3. Over Limit = Level - Limit Line
 4. The peak result complies with AVG limit, AVG result is deemed to comply with AVG limit.
 5. The other emission levels were very low against the limit.

Site :HC-C802
 Condition :3m Vertical
 Mode :g_TX_2437MHz
 Test By :Gary

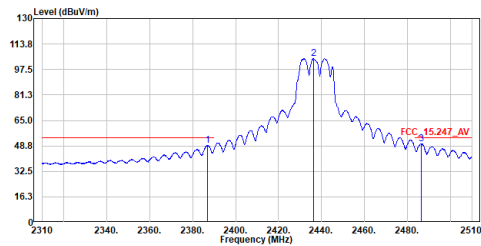

No.	Frequency MHz	Level dBuV/m	Limit Line dBuV/m	Over Limit dB	Read Level dBuV	Factor dB	Remark
1	2386.900	48.93	54.00	-5.07	37.04	11.89	Average
2	2436.200	104.45	-----	-----	92.30	12.15	Average
3	2486.500	50.11	54.00	-3.89	37.70	12.41	Average

Note:
 1. Level = Read Level + Factor
 2. Factor = Antenna Factor + Cable Loss - Preamp Factor
 3. Over Limit = Level - Limit Line
 4. The peak result complies with AVG limit, AVG result is deemed to comply with AVG limit.
 5. The other emission levels were very low against the limit.

Site :HC-C802
 Condition :3m Vertical
 Mode :g_TX_2437MHz
 Test By :Gary

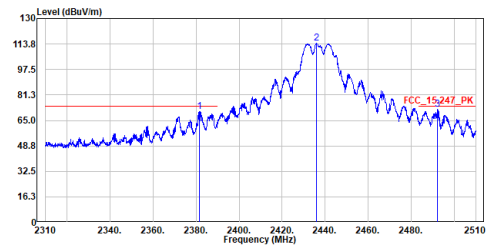

No.	Frequency MHz	Level dBuV/m	Limit Line dBuV/m	Over Limit dB	Read Level dBuV	Factor dB	Remark
1	2381.700	70.64	74.00	-3.36	58.77	11.87	Peak
2	2435.800	114.08	-----	-----	101.93	12.15	Peak
3	2492.000	72.15	74.00	-1.85	59.71	12.44	Peak

Note:
 1. Level = Read Level + Factor
 2. Factor = Antenna Factor + Cable Loss - Preamp Factor
 3. Over Limit = Level - Limit Line
 4. The peak result complies with AVG limit, AVG result is deemed to comply with AVG limit.
 5. The other emission levels were very low against the limit.

Site :HC-C802
 Condition :3m Horizontal
 Mode :g_TX_2437MHz
 Test By :Gary

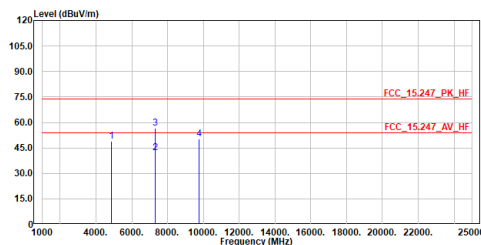

No.	Frequency MHz	Level dBuV/m	Limit Line dBuV/m	Over Limit dB	Read Level dBuV	Factor dB	Remark
1	4874.000	48.82	74.00	-25.18	63.30	-14.48	Peak
2	7311.000	41.92	54.00	-12.08	49.80	-7.88	Average
3	7311.000	56.75	74.00	-17.25	64.63	-7.88	Peak
4	9748.000	50.33	74.00	-23.67	54.61	-4.28	Peak

Note:
 1. Level = Read Level + Factor
 2. Factor = Antenna Factor + Cable Loss - Preamp Factor
 3. Over Limit = Level - Limit Line
 4. The peak result complies with AVG limit, AVG result is deemed to comply with AVG limit.
 5. The other emission levels were very low against the limit.

Site :HC-C802
 Condition :3m Vertical
 Mode :g_TX_2437MHz
 Test By :Gary

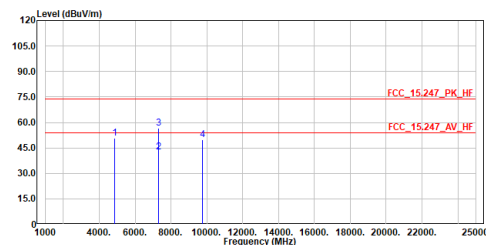

No.	Frequency MHz	Level dBuV/m	Limit Line dBuV/m	Over Limit dB	Read Level dBuV	Factor dB	Remark
1	4874.000	50.79	74.00	-23.21	65.27	-14.48	Peak
2	7311.000	42.63	54.00	-11.37	50.51	-7.88	Average
3	7311.000	56.83	74.00	-17.17	64.71	-7.88	Peak
4	9748.000	49.80	74.00	-24.20	54.08	-4.28	Peak

Note:
 1. Level = Read Level + Factor
 2. Factor = Antenna Factor + Cable Loss - Preamp Factor
 3. Over Limit = Level - Limit Line
 4. The peak result complies with AVG limit, AVG result is deemed to comply with AVG limit.
 5. The other emission levels were very low against the limit.

Site :HC-C802
 Condition :3m Horizontal
 Mode :g_TX_2452MHz
 Test By :Gary

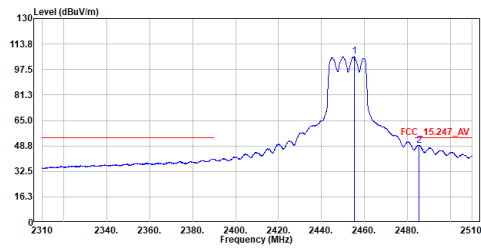

No.	Frequency MHz	Level dBuV/m	Limit Line dBuV/m	Over Limit dB	Read Level dBuV	Factor dB	Remark
1	2455.200	105.73	-----	-----	93.48	12.25	Average
2	2485.400	49.20	54.00	-4.80	36.79	12.41	Average

Note:
 1. Level = Read Level + Factor
 2. Factor = Antenna Factor + Cable Loss - Preamp Factor
 3. Over Limit = Level - Limit Line
 4. The peak result complies with AVG limit, AVG result is deemed to comply with AVG limit.
 5. The other emission levels were very low against the limit.

Site :HC-C802
 Condition :3m Horizontal
 Mode :g_TX_2452MHz
 Test By :Gary

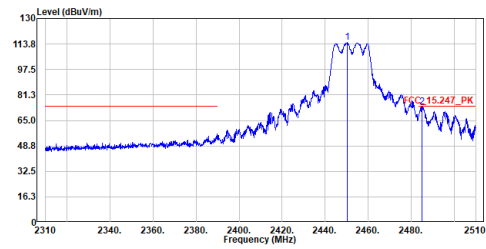

No.	Frequency MHz	Level dBuV/m	Limit Line dBuV/m	Over Limit dB	Read Level dBuV	Factor dB	Remark
1	2450.300	114.97	-----	-----	102.75	12.22	Peak
2	2485.000	73.78	74.00	-0.22	61.37	12.41	Peak

Note:
 1. Level = Read Level + Factor
 2. Factor = Antenna Factor + Cable Loss - Preamp Factor
 3. Over Limit = Level - Limit Line
 4. The peak result complies with AVG limit, AVG result is deemed to comply with AVG limit.
 5. The other emission levels were very low against the limit.

Site :HC-C802
 Condition :3m Vertical
 Mode :g_TX_2452MHz
 Test By :Gary

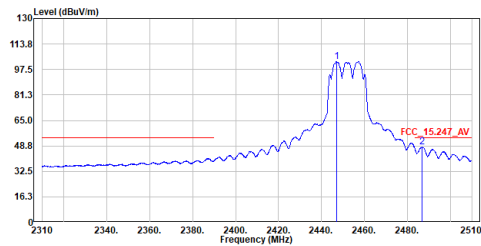

No.	Frequency MHz	Level dBuV/m	Limit Line dBuV/m	Over Limit dB	Read Level dBuV	Factor dB	Remark
1	2447.000	102.54	-----	-----	90.33	12.21	Average
2	2486.900	47.94	54.00	-6.06	35.52	12.42	Average

Note:
 1. Level = Read Level + Factor
 2. Factor = Antenna Factor + Cable Loss - Preamp Factor
 3. Over Limit = Level - Limit Line
 4. The peak result complies with AVG limit, AVG result is deemed to comply with AVG limit.
 5. The other emission levels were very low against the limit.

Site :HC-C802
 Condition :3m Vertical
 Mode :g_TX_2452MHz
 Test By :Gary

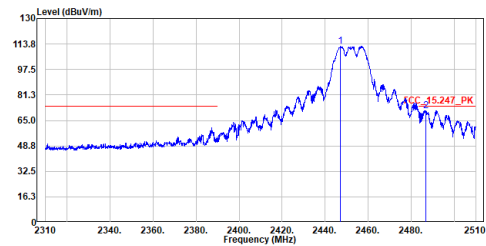

No.	Frequency MHz	Level dBuV/m	Limit Line dBuV/m	Over Limit dB	Read Level dBuV	Factor dB	Remark
1	2447.000	112.35	-----	-----	100.14	12.21	Peak
2	2486.800	71.35	74.00	-2.65	58.93	12.42	Peak

Note:
 1. Level = Read Level + Factor
 2. Factor = Antenna Factor + Cable Loss - Preamp Factor
 3. Over Limit = Level - Limit Line
 4. The peak result complies with AVG limit, AVG result is deemed to comply with AVG limit.
 5. The other emission levels were very low against the limit.

Site :HC-CB02
 Condition :3m Horizontal
 Mode :g_TX_2452MHz
 Test By :Gary

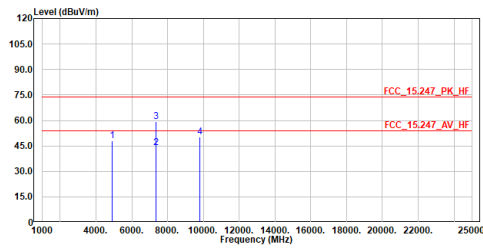

No.	Frequency MHz	Level dBuV/m	Limit Line dBuV/m	Over Limit dB	Read Level dBuV	Factor dB	Remark
1	4904.000	48.07	74.00	-25.93	62.43	-14.36	Peak
2	7356.000	43.81	54.00	-10.19	51.64	-7.83	Average
3	7356.000	59.42	74.00	-14.58	67.25	-7.83	Peak
4	9808.000	50.39	74.00	-23.61	54.55	-4.16	Peak

Note:
 1. Level = Read Level + Factor
 2. Factor = Antenna Factor + Cable Loss - Preamp Factor
 3. Over Limit = Level - Limit Line
 4. The peak result complies with AVG limit, AVG result is deemed to comply with AVG limit.
 5. The other emission levels were very low against the limit.

Site :HC-CB02
 Condition :3m Vertical
 Mode :g_TX_2452MHz
 Test By :Gary

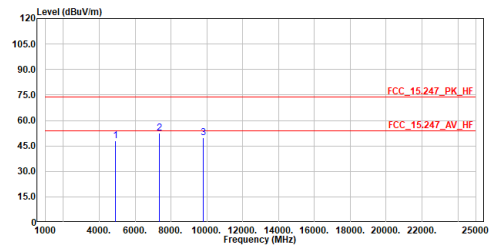

No.	Frequency MHz	Level dBuV/m	Limit Line dBuV/m	Over Limit dB	Read Level dBuV	Factor dB	Remark
1	4904.000	48.08	74.00	-25.92	62.44	-14.36	Peak
2	7356.000	52.48	74.00	-21.52	60.31	-7.83	Peak
3	9808.000	49.77	74.00	-24.23	53.93	-4.16	Peak

Note:
 1. Level = Read Level + Factor
 2. Factor = Antenna Factor + Cable Loss - Preamp Factor
 3. Over Limit = Level - Limit Line
 4. The peak result complies with AVG limit, AVG result is deemed to comply with AVG limit.
 5. The other emission levels were very low against the limit.

Site :HC-CB02
 Condition :3m Horizontal
 Mode :g_TX_2462MHz
 Test By :Gary

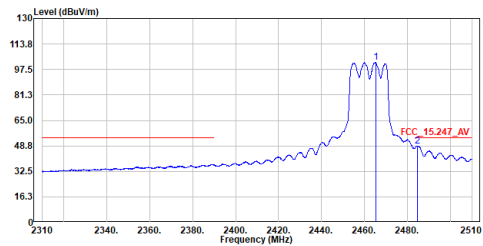

No.	Frequency MHz	Level dBuV/m	Limit Line dBuV/m	Over Limit dB	Read Level dBuV	Factor dB	Remark
1	2465.200	102.05	-----	-----	89.74	12.31	Average
2	2484.500	48.72	54.00	-5.28	36.31	12.41	Average

Note:
 1. Level = Read Level + Factor
 2. Factor = Antenna Factor + Cable Loss - Preamp Factor
 3. Over Limit = Level - Limit Line
 4. The peak result complies with AVG limit, AVG result is deemed to comply with AVG limit.
 5. The other emission levels were very low against the limit.

Site :HC-CB02
 Condition :3m Horizontal
 Mode :g_TX_2462MHz
 Test By :Gary

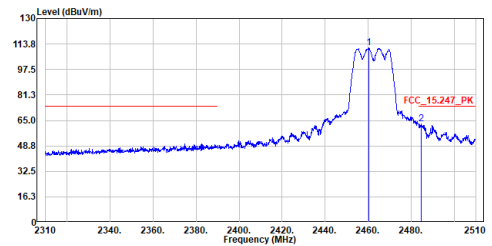

No.	Frequency MHz	Level dBuV/m	Limit Line dBuV/m	Over Limit dB	Read Level dBuV	Factor dB	Remark
1	2460.400	111.21	-----	-----	98.92	12.29	Peak
2	2484.600	62.66	74.00	-11.34	50.25	12.41	Peak

Note:
 1. Level = Read Level + Factor
 2. Factor = Antenna Factor + Cable Loss - Preamp Factor
 3. Over Limit = Level - Limit Line
 4. The peak result complies with AVG limit, AVG result is deemed to comply with AVG limit.
 5. The other emission levels were very low against the limit.

Site :HC-CB02
 Condition :3m Vertical
 Mode :g_TX_2462MHz
 Test By :Gary

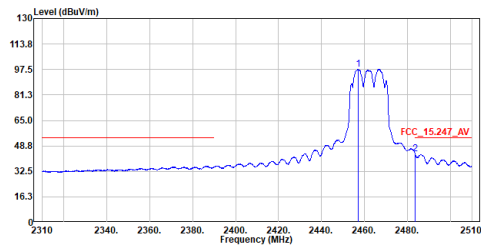

No.	Frequency MHz	Level dBuV/m	Limit Line dBuV/m	Over Limit dB	Read Level dBuV	Factor dB	Remark
1	2457.000	97.61	-----	-----	85.35	12.26	Average
2	2483.600	43.44	54.00	-10.56	31.04	12.40	Average

Note:
 1. Level = Read Level + Factor
 2. Factor = Antenna Factor + Cable Loss - Preamp Factor
 3. Over Limit = Level - Limit Line
 4. The peak result complies with AVG limit, AVG result is deemed to comply with AVG limit.
 5. The other emission levels were very low against the limit.

Site :HC-CB02
 Condition :3m Vertical
 Mode :g_TX_2462MHz
 Test By :Gary

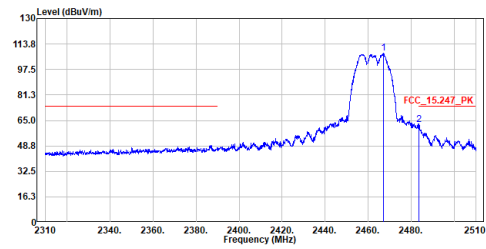

No.	Frequency MHz	Level dBuV/m	Limit Line dBuV/m	Over Limit dB	Read Level dBuV	Factor dB	Remark
1	2467.100	107.86	-----	-----	95.55	12.31	Peak
2	2483.700	62.29	74.00	-11.71	49.88	12.41	Peak

Note:
 1. Level = Read Level + Factor
 2. Factor = Antenna Factor + Cable Loss - Preamp Factor
 3. Over Limit = Level - Limit Line
 4. The peak result complies with AVG limit, AVG result is deemed to comply with AVG limit.
 5. The other emission levels were very low against the limit.

Site :HC-CB02
 Condition :3m Horizontal
 Mode :g_TX_2462MHz
 Test By :Gary

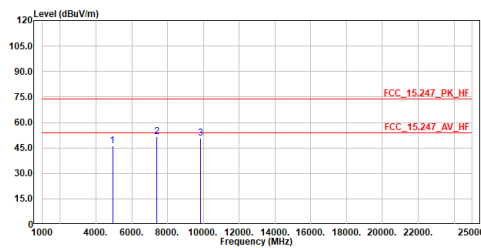

No.	Frequency MHz	Level dBuV/m	Limit Line dBuV/m	Over Limit dB	Read Level dBuV	Factor dB	Remark
1	4924.000	46.19	74.00	-27.81	60.47	-14.28	Peak
2	7386.000	51.47	74.00	-22.53	59.26	-7.79	Peak
3	9848.000	50.57	74.00	-23.43	54.65	-4.08	Peak

Note:
 1. Level = Read Level + Factor
 2. Factor = Antenna Factor + Cable Loss - Preamp Factor
 3. Over Limit = Level - Limit Line
 4. The peak result complies with AVG limit, AVG result is deemed to comply with AVG limit.
 5. The other emission levels were very low against the limit.

Site :HC-CB02
 Condition :3m Vertical
 Mode :g_TX_2462MHz
 Test By :Gary

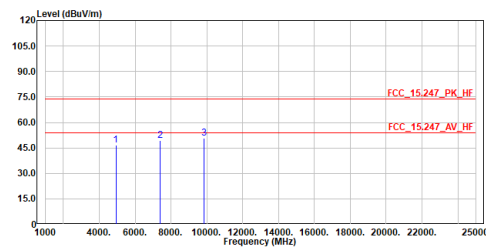

No.	Frequency MHz	Level dBuV/m	Limit Line dBuV/m	Over Limit dB	Read Level dBuV	Factor dB	Remark
1	4924.000	46.72	74.00	-27.28	61.00	-14.28	Peak
2	7386.000	49.55	74.00	-24.45	57.34	-7.79	Peak
3	9848.000	50.54	74.00	-23.46	54.62	-4.08	Peak

Note:
 1. Level = Read Level + Factor
 2. Factor = Antenna Factor + Cable Loss - Preamp Factor
 3. Over Limit = Level - Limit Line
 4. The peak result complies with AVG limit, AVG result is deemed to comply with AVG limit.
 5. The other emission levels were very low against the limit.

Site :HC-CB02
 Condition :3m Horizontal
 Mode :n20_TX_2412MHz
 Test By :Gary

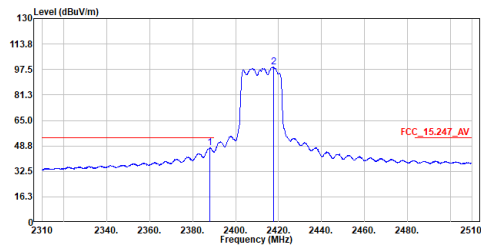

No.	Frequency	Level	Limit	Over	Read	Factor	Remark
	MHz	dBuV/m	dBuV/m	dB	dBuV	dB	
1	2388.000	47.44	54.00	-6.56	35.54	11.90	Average
2	2417.600	99.14	-----	-----	87.08	12.06	Average

Note:
 1. Level = Read Level + Factor
 2. Factor = Antenna Factor + Cable Loss - Preamp Factor
 3. Over Limit = Level - Limit Line
 4. The peak result complies with AVG limit, AVG result is deemed to comply with AVG limit.
 5. The other emission levels were very low against the limit.

Site :HC-CB02
 Condition :3m Horizontal
 Mode :n20_TX_2412MHz
 Test By :Gary

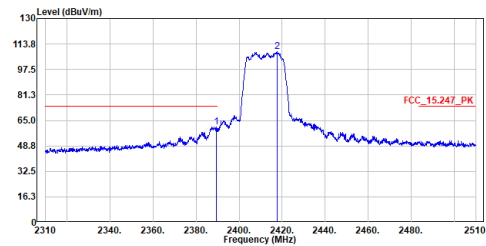

No.	Frequency	Level	Limit	Over	Read	Factor	Remark
	MHz	dBuV/m	dBuV/m	dB	dBuV	dB	
1	2389.500	61.03	74.00	-12.97	49.12	11.91	Peak
2	2417.600	108.90	-----	-----	96.84	12.06	Peak

Note:
 1. Level = Read Level + Factor
 2. Factor = Antenna Factor + Cable Loss - Preamp Factor
 3. Over Limit = Level - Limit Line
 4. The peak result complies with AVG limit, AVG result is deemed to comply with AVG limit.
 5. The other emission levels were very low against the limit.

Site :HC-CB02
 Condition :3m Vertical
 Mode :n20_TX_2412MHz
 Test By :Gary

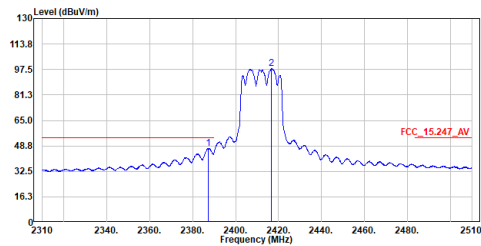

No.	Frequency	Level	Limit	Over	Read	Factor	Remark
	MHz	dBuV/m	dBuV/m	dB	dBuV	dB	
1	2387.400	47.28	54.00	-6.72	35.39	11.89	Average
2	2416.700	98.26	-----	-----	86.21	12.05	Average

Note:
 1. Level = Read Level + Factor
 2. Factor = Antenna Factor + Cable Loss - Preamp Factor
 3. Over Limit = Level - Limit Line
 4. The peak result complies with AVG limit, AVG result is deemed to comply with AVG limit.
 5. The other emission levels were very low against the limit.

Site :HC-CB02
 Condition :3m Vertical
 Mode :n20_TX_2412MHz
 Test By :Gary

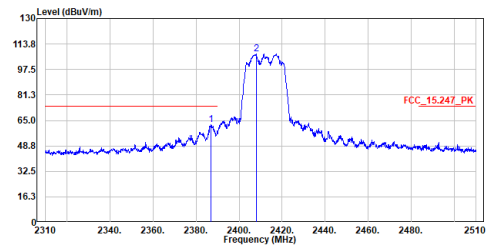

No.	Frequency	Level	Limit	Over	Read	Factor	Remark
	MHz	dBuV/m	dBuV/m	dB	dBuV	dB	
1	2387.000	62.51	74.00	-11.49	50.62	11.89	Peak
2	2408.100	107.67	-----	-----	95.66	12.01	Peak

Note:
 1. Level = Read Level + Factor
 2. Factor = Antenna Factor + Cable Loss - Preamp Factor
 3. Over Limit = Level - Limit Line
 4. The peak result complies with AVG limit, AVG result is deemed to comply with AVG limit.
 5. The other emission levels were very low against the limit.

Site :HC-C802
 Condition :3m Horizontal
 Mode :n20_TX_2412MHz
 Test By :Gary

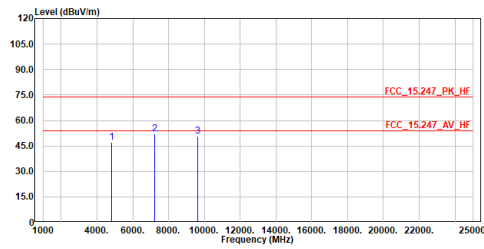

No.	Frequency MHz	Level dBuV/m	Limit Line dBuV/m	Over Limit dB	Read Level dBuV	Factor dB	Remark
1	4824.000	47.09	74.00	-26.91	61.77	-14.68	Peak
2	7236.000	52.30	74.00	-21.70	60.25	-7.95	Peak
3	9648.000	50.63	74.00	-23.37	55.11	-4.48	Peak

Note:
 1. Level = Read Level + Factor
 2. Factor = Antenna Factor + Cable Loss - Preamp Factor
 3. Over Limit = Level - Limit Line
 4. The peak result complies with AVG limit, AVG result is deemed to comply with AVG limit.
 5. The other emission levels were very low against the limit.

Site :HC-C802
 Condition :3m Vertical
 Mode :n20_TX_2412MHz
 Test By :Gary

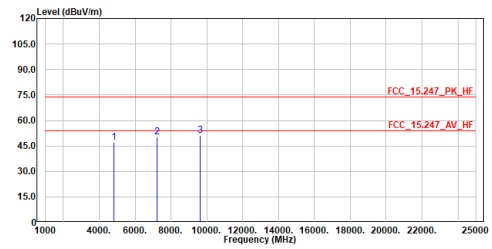

No.	Frequency MHz	Level dBuV/m	Limit Line dBuV/m	Over Limit dB	Read Level dBuV	Factor dB	Remark
1	4824.000	47.12	74.00	-26.88	61.80	-14.68	Peak
2	7236.000	50.48	74.00	-23.52	58.43	-7.95	Peak
3	9648.000	51.12	74.00	-22.88	55.60	-4.48	Peak

Note:
 1. Level = Read Level + Factor
 2. Factor = Antenna Factor + Cable Loss - Preamp Factor
 3. Over Limit = Level - Limit Line
 4. The peak result complies with AVG limit, AVG result is deemed to comply with AVG limit.
 5. The other emission levels were very low against the limit.

Site :HC-C802
 Condition :3m Horizontal
 Mode :n20_TX_2422MHz
 Test By :Gary

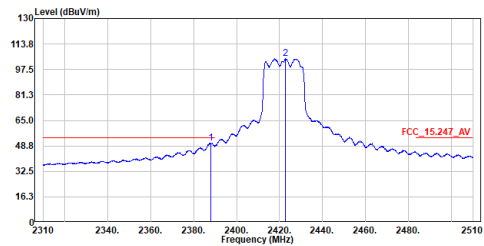

No.	Frequency MHz	Level dBuV/m	Limit Line dBuV/m	Over Limit dB	Read Level dBuV	Factor dB	Remark
1	2387.900	50.61	54.00	-3.39	38.71	11.90	Average
2	2422.600	104.29	-----	-----	92.21	12.08	Average

Note:
 1. Level = Read Level + Factor
 2. Factor = Antenna Factor + Cable Loss - Preamp Factor
 3. Over Limit = Level - Limit Line
 4. The peak result complies with AVG limit, AVG result is deemed to comply with AVG limit.
 5. The other emission levels were very low against the limit.

Site :HC-C802
 Condition :3m Horizontal
 Mode :n20_TX_2422MHz
 Test By :Gary

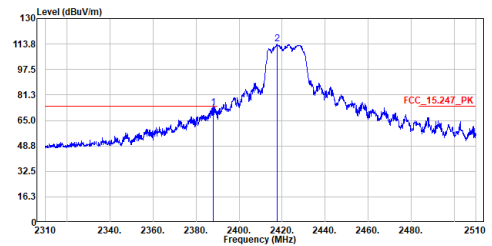

No.	Frequency MHz	Level dBuV/m	Limit Line dBuV/m	Over Limit dB	Read Level dBuV	Factor dB	Remark
1	2388.000	73.01	74.00	-0.99	61.11	11.90	Peak
2	2417.600	113.59	-----	-----	101.53	12.06	Peak

Note:
 1. Level = Read Level + Factor
 2. Factor = Antenna Factor + Cable Loss - Preamp Factor
 3. Over Limit = Level - Limit Line
 4. The peak result complies with AVG limit, AVG result is deemed to comply with AVG limit.
 5. The other emission levels were very low against the limit.

Site :HC-CB02
 Condition :3m Vertical
 Mode :n20_TX_2422MHz
 Test By :Gary

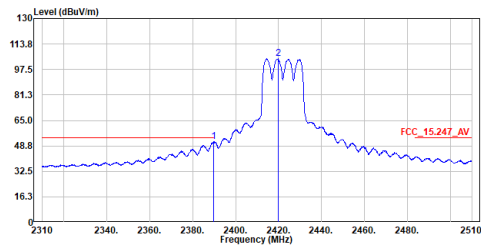

No.	Frequency MHz	Level dBuV/m	Limit Line dBuV/m	Over Limit dB	Read Level dBuV	Factor dB	Remark
1	2389.800	51.39	54.00	-2.61	39.48	11.91	Average
2	2419.700	104.40	-----	-----	92.33	12.07	Average

Note:
 1. Level = Read Level + Factor
 2. Factor = Antenna Factor + Cable Loss - Preamp Factor
 3. Over Limit = Level - Limit Line
 4. The peak result complies with AVG limit, AVG result is deemed to comply with AVG limit.
 5. The other emission levels were very low against the limit.

Site :HC-CB02
 Condition :3m Vertical
 Mode :n20_TX_2422MHz
 Test By :Gary

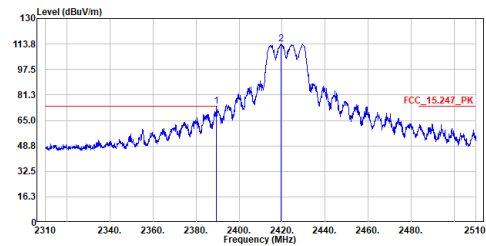

No.	Frequency MHz	Level dBuV/m	Limit Line dBuV/m	Over Limit dB	Read Level dBuV	Factor dB	Remark
1	2389.500	73.95	74.00	-0.05	62.04	11.91	Peak
2	2419.400	113.88	-----	-----	101.81	12.07	Peak

Note:
 1. Level = Read Level + Factor
 2. Factor = Antenna Factor + Cable Loss - Preamp Factor
 3. Over Limit = Level - Limit Line
 4. The peak result complies with AVG limit, AVG result is deemed to comply with AVG limit.
 5. The other emission levels were very low against the limit.

Site :HC-CB02
 Condition :3m Horizontal
 Mode :n20_TX_2422MHz
 Test By :Gary

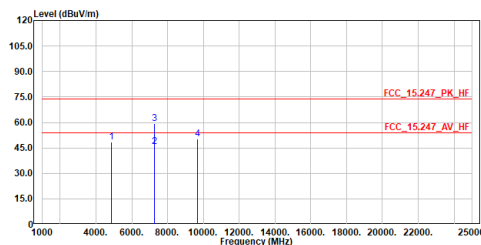

No.	Frequency MHz	Level dBuV/m	Limit Line dBuV/m	Over Limit dB	Read Level dBuV	Factor dB	Remark
1	4844.000	48.46	74.00	-25.54	63.06	-14.60	Peak
2	7266.000	45.55	54.00	-8.45	53.48	-7.93	Average
3	7266.000	59.21	74.00	-14.79	67.14	-7.93	Peak
4	9688.000	50.46	74.00	-23.54	54.86	-4.40	Peak

Note:
 1. Level = Read Level + Factor
 2. Factor = Antenna Factor + Cable Loss - Preamp Factor
 3. Over Limit = Level - Limit Line
 4. The peak result complies with AVG limit, AVG result is deemed to comply with AVG limit.
 5. The other emission levels were very low against the limit.

Site :HC-CB02
 Condition :3m Vertical
 Mode :n20_TX_2422MHz
 Test By :Gary

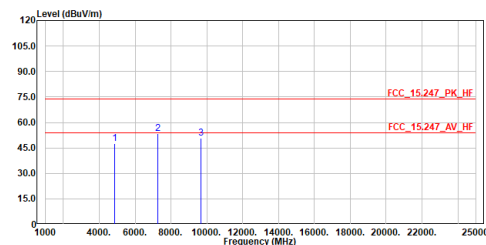

No.	Frequency MHz	Level dBuV/m	Limit Line dBuV/m	Over Limit dB	Read Level dBuV	Factor dB	Remark
1	4844.000	47.42	74.00	-26.58	62.02	-14.60	Peak
2	7266.000	53.51	74.00	-20.49	61.44	-7.93	Peak
3	9688.000	50.57	74.00	-23.43	54.97	-4.40	Peak

Note:
 1. Level = Read Level + Factor
 2. Factor = Antenna Factor + Cable Loss - Preamp Factor
 3. Over Limit = Level - Limit Line
 4. The peak result complies with AVG limit, AVG result is deemed to comply with AVG limit.
 5. The other emission levels were very low against the limit.

Site :HC-CB02
 Condition :3m Horizontal
 Mode :n20_TX_2437MHz
 Test By :Gary

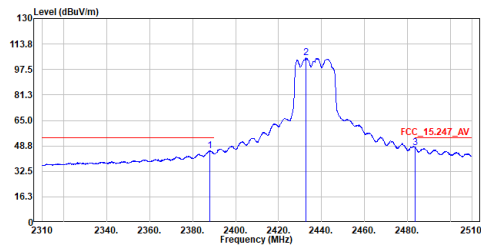

No.	Frequency MHz	Level dBuV/m	Limit Line dBuV/m	Over Limit dB	Read Level dBuV	Factor dB	Remark
1	2388.000	45.54	54.00	-8.46	33.64	11.90	Average
2	2432.700	104.89	-----	-----	92.75	12.14	Average
3	2483.700	47.60	54.00	-6.40	35.19	12.41	Average

Note:
 1. Level = Read Level + Factor
 2. Factor = Antenna Factor + Cable Loss - Preamp Factor
 3. Over Limit = Level - Limit Line
 4. The peak result complies with AVG limit, AVG result is deemed to comply with AVG limit.
 5. The other emission levels were very low against the limit.

Site :HC-CB02
 Condition :3m Horizontal
 Mode :n20_TX_2437MHz
 Test By :Gary

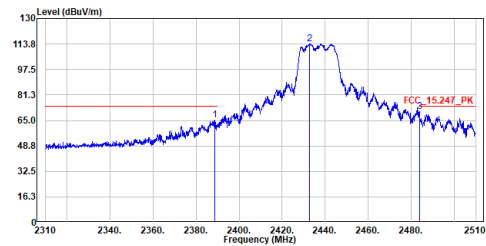

No.	Frequency MHz	Level dBuV/m	Limit Line dBuV/m	Over Limit dB	Read Level dBuV	Factor dB	Remark
1	2388.000	65.29	74.00	-8.71	53.38	11.91	Peak
2	2432.800	114.01	-----	-----	101.87	12.14	Peak
3	2484.000	70.48	74.00	-3.52	58.07	12.41	Peak

Note:
 1. Level = Read Level + Factor
 2. Factor = Antenna Factor + Cable Loss - Preamp Factor
 3. Over Limit = Level - Limit Line
 4. The peak result complies with AVG limit, AVG result is deemed to comply with AVG limit.
 5. The other emission levels were very low against the limit.

Site :HC-CB02
 Condition :3m Vertical
 Mode :n20_TX_2437MHz
 Test By :Gary

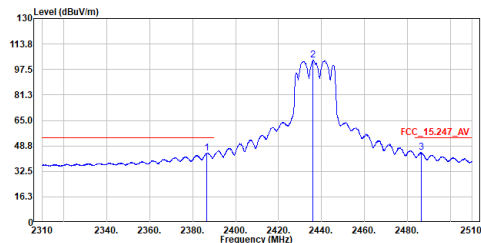

No.	Frequency MHz	Level dBuV/m	Limit Line dBuV/m	Over Limit dB	Read Level dBuV	Factor dB	Remark
1	2386.700	44.39	54.00	-9.61	32.50	11.89	Average
2	2436.100	103.40	-----	-----	91.25	12.15	Average
3	2486.400	44.58	54.00	-9.42	32.17	12.41	Average

Note:
 1. Level = Read Level + Factor
 2. Factor = Antenna Factor + Cable Loss - Preamp Factor
 3. Over Limit = Level - Limit Line
 4. The peak result complies with AVG limit, AVG result is deemed to comply with AVG limit.
 5. The other emission levels were very low against the limit.

Site :HC-CB02
 Condition :3m Vertical
 Mode :n20_TX_2437MHz
 Test By :Gary

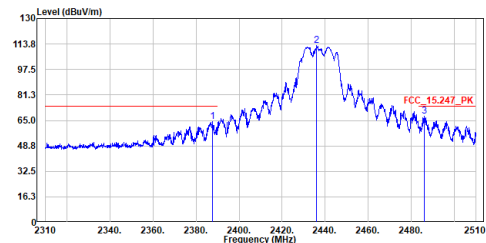

No.	Frequency MHz	Level dBuV/m	Limit Line dBuV/m	Over Limit dB	Read Level dBuV	Factor dB	Remark
1	2387.600	64.36	74.00	-9.64	52.46	11.90	Peak
2	2436.100	112.81	-----	-----	100.66	12.15	Peak
3	2486.100	67.59	74.00	-6.41	55.18	12.41	Peak

Note:
 1. Level = Read Level + Factor
 2. Factor = Antenna Factor + Cable Loss - Preamp Factor
 3. Over Limit = Level - Limit Line
 4. The peak result complies with AVG limit, AVG result is deemed to comply with AVG limit.
 5. The other emission levels were very low against the limit.

Site :HC-C802
 Condition :3m Horizontal
 Mode :n20_TX_2437MHz
 Test By :Gary

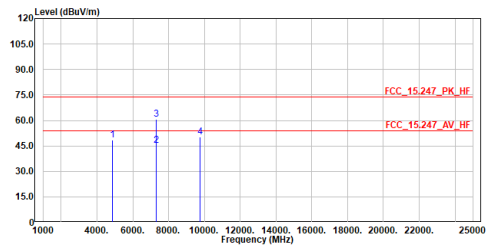

No.	Frequency	Level	Limit	Over	Read	Factor	Remark
	MHz	dBuV/m	dBuV/m	dB	dBuV	dB	
1	4874.000	48.58	74.00	-25.42	63.06	-14.48	Peak
2	7311.000	45.26	54.00	-8.74	53.14	-7.88	Average
3	7311.000	60.63	74.00	-13.37	68.51	-7.88	Peak
4	9748.000	50.40	74.00	-23.60	54.68	-4.28	Peak

Note:
 1. Level = Read Level + Factor
 2. Factor = Antenna Factor + Cable Loss - Preamp Factor
 3. Over Limit = Level - Limit Line
 4. The peak result complies with AVG limit, AVG result is deemed to comply with AVG limit.
 5. The other emission levels were very low against the limit.

Site :HC-C802
 Condition :3m Vertical
 Mode :n20_TX_2437MHz
 Test By :Gary

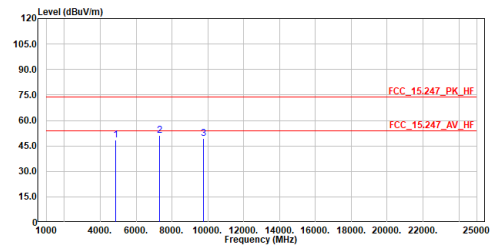

No.	Frequency	Level	Limit	Over	Read	Factor	Remark
	MHz	dBuV/m	dBuV/m	dB	dBuV	dB	
1	4874.000	48.61	74.00	-25.39	63.09	-14.48	Peak
2	7311.000	51.29	74.00	-22.71	59.17	-7.88	Peak
3	9748.000	49.38	74.00	-24.62	53.66	-4.28	Peak

Note:
 1. Level = Read Level + Factor
 2. Factor = Antenna Factor + Cable Loss - Preamp Factor
 3. Over Limit = Level - Limit Line
 4. The peak result complies with AVG limit, AVG result is deemed to comply with AVG limit.
 5. The other emission levels were very low against the limit.

Site :HC-C802
 Condition :3m Horizontal
 Mode :n20_TX_2452MHz
 Test By :Gary

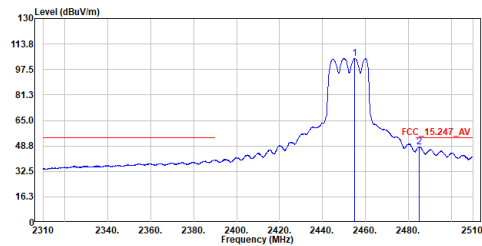

No.	Frequency	Level	Limit	Over	Read	Factor	Remark
	MHz	dBuV/m	dBuV/m	dB	dBuV	dB	
1	2455.000	104.64	-----	-----	92.39	12.25	Average
2	2485.000	48.12	54.00	-5.88	35.71	12.41	Average

Note:
 1. Level = Read Level + Factor
 2. Factor = Antenna Factor + Cable Loss - Preamp Factor
 3. Over Limit = Level - Limit Line
 4. The peak result complies with AVG limit, AVG result is deemed to comply with AVG limit.
 5. The other emission levels were very low against the limit.

Site :HC-C802
 Condition :3m Horizontal
 Mode :n20_TX_2452MHz
 Test By :Gary

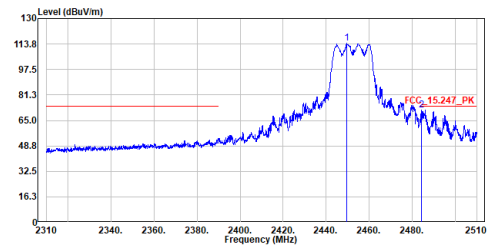

No.	Frequency	Level	Limit	Over	Read	Factor	Remark
	MHz	dBuV/m	dBuV/m	dB	dBuV	dB	
1	2449.600	114.12	-----	-----	101.90	12.22	Peak
2	2484.300	71.56	74.00	-2.44	59.15	12.41	Peak

Note:
 1. Level = Read Level + Factor
 2. Factor = Antenna Factor + Cable Loss - Preamp Factor
 3. Over Limit = Level - Limit Line
 4. The peak result complies with AVG limit, AVG result is deemed to comply with AVG limit.
 5. The other emission levels were very low against the limit.

Site :HC-CB02
 Condition :3m Vertical
 Mode :n20_TX_2452MHz
 Test By :Gary

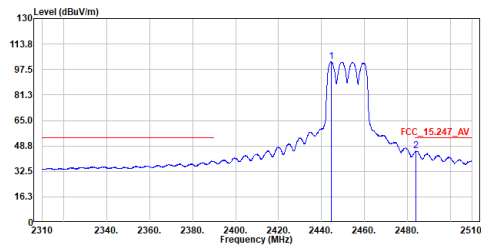

No.	Frequency	Level	Limit	Over	Read	Factor	Remark
	MHz	dBuV/m	dBuV/m	dB	dBuV	dB	
1	2444.500	102.71	-----	-----	90.51	12.20	Average
2	2484.100	45.56	54.00	-8.44	33.15	12.41	Average

Note:
 1. Level = Read Level + Factor
 2. Factor = Antenna Factor + Cable Loss - Preamp Factor
 3. Over Limit = Level - Limit Line
 4. The peak result complies with AVG limit, AVG result is deemed to comply with AVG limit.
 5. The other emission levels were very low against the limit.

Site :HC-CB02
 Condition :3m Vertical
 Mode :n20_TX_2452MHz
 Test By :Gary

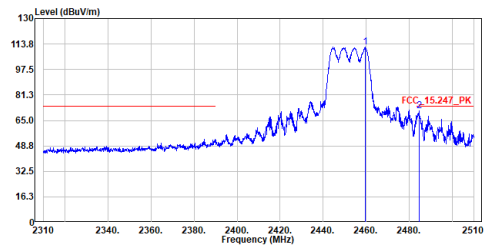

No.	Frequency	Level	Limit	Over	Read	Factor	Remark
	MHz	dBuV/m	dBuV/m	dB	dBuV	dB	
1	2459.600	112.08	-----	-----	99.81	12.27	Peak
2	2484.500	71.31	74.00	-2.69	58.90	12.41	Peak

Note:
 1. Level = Read Level + Factor
 2. Factor = Antenna Factor + Cable Loss - Preamp Factor
 3. Over Limit = Level - Limit Line
 4. The peak result complies with AVG limit, AVG result is deemed to comply with AVG limit.
 5. The other emission levels were very low against the limit.

Site :HC-CB02
 Condition :3m Horizontal
 Mode :n20_TX_2452MHz
 Test By :Gary

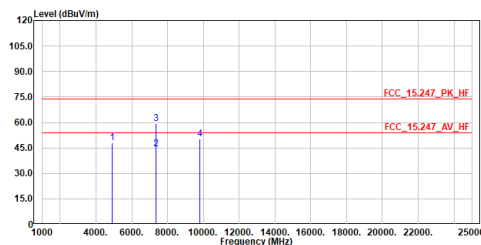

No.	Frequency	Level	Limit	Over	Read	Factor	Remark
	MHz	dBuV/m	dBuV/m	dB	dBuV	dB	
1	4904.000	47.89	74.00	-26.11	62.25	-14.36	Peak
2	7356.000	44.59	54.00	-9.41	52.42	-7.83	Average
3	7356.000	59.19	74.00	-14.81	67.02	-7.83	Peak
4	9808.000	50.13	74.00	-23.87	54.29	-4.16	Peak

Note:
 1. Level = Read Level + Factor
 2. Factor = Antenna Factor + Cable Loss - Preamp Factor
 3. Over Limit = Level - Limit Line
 4. The peak result complies with AVG limit, AVG result is deemed to comply with AVG limit.
 5. The other emission levels were very low against the limit.

Site :HC-CB02
 Condition :3m Vertical
 Mode :n20_TX_2452MHz
 Test By :Gary

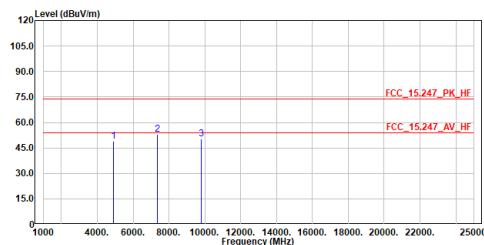

No.	Frequency	Level	Limit	Over	Read	Factor	Remark
	MHz	dBuV/m	dBuV/m	dB	dBuV	dB	
1	4904.000	48.80	74.00	-25.20	63.16	-14.36	Peak
2	7356.000	52.81	74.00	-21.19	60.64	-7.83	Peak
3	9808.000	50.47	74.00	-23.53	54.63	-4.16	Peak

Note:
 1. Level = Read Level + Factor
 2. Factor = Antenna Factor + Cable Loss - Preamp Factor
 3. Over Limit = Level - Limit Line
 4. The peak result complies with AVG limit, AVG result is deemed to comply with AVG limit.
 5. The other emission levels were very low against the limit.

Site :HC-CB02
 Condition :3m Horizontal
 Mode :n20_TX_2462MHz
 Test By :Gary

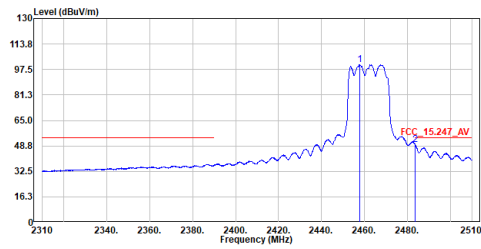

No.	Frequency MHz	Level dBuV/m	Limit Line dBuV/m	Over Limit dB	Read Level dBuV	Factor dB	Remark
1	2457.700	100.71	-----	-----	88.44	12.27	Average
2	2483.600	49.56	54.00	-4.44	37.16	12.40	Average

Note:
 1. Level = Read Level + Factor
 2. Factor = Antenna Factor + Cable Loss - Preamp Factor
 3. Over Limit = Level - Limit Line
 4. The peak result complies with AVG limit, AVG result is deemed to comply with AVG limit.
 5. The other emission levels were very low against the limit.

Site :HC-CB02
 Condition :3m Horizontal
 Mode :n20_TX_2462MHz
 Test By :Gary

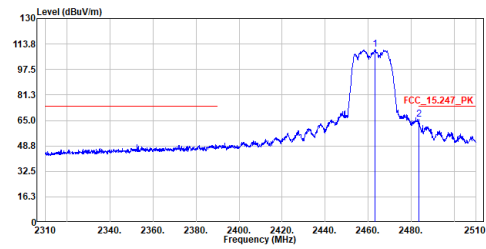

No.	Frequency MHz	Level dBuV/m	Limit Line dBuV/m	Over Limit dB	Read Level dBuV	Factor dB	Remark
1	2463.100	110.48	-----	-----	98.18	12.30	Peak
2	2483.600	65.58	74.00	-8.42	53.18	12.40	Peak

Note:
 1. Level = Read Level + Factor
 2. Factor = Antenna Factor + Cable Loss - Preamp Factor
 3. Over Limit = Level - Limit Line
 4. The peak result complies with AVG limit, AVG result is deemed to comply with AVG limit.
 5. The other emission levels were very low against the limit.

Site :HC-CB02
 Condition :3m Vertical
 Mode :n20_TX_2462MHz
 Test By :Gary

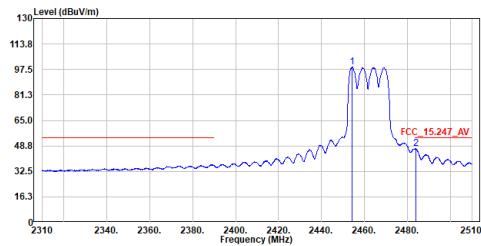

No.	Frequency MHz	Level dBuV/m	Limit Line dBuV/m	Over Limit dB	Read Level dBuV	Factor dB	Remark
1	2454.300	98.92	-----	-----	86.67	12.25	Average
2	2484.000	47.20	54.00	-6.80	34.79	12.41	Average

Note:
 1. Level = Read Level + Factor
 2. Factor = Antenna Factor + Cable Loss - Preamp Factor
 3. Over Limit = Level - Limit Line
 4. The peak result complies with AVG limit, AVG result is deemed to comply with AVG limit.
 5. The other emission levels were very low against the limit.

Site :HC-CB02
 Condition :3m Vertical
 Mode :n20_TX_2462MHz
 Test By :Gary

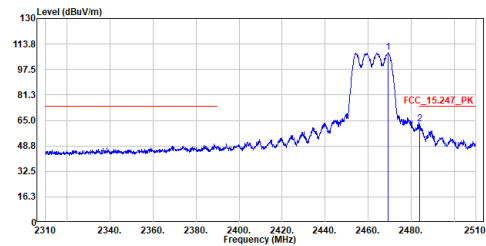

No.	Frequency MHz	Level dBuV/m	Limit Line dBuV/m	Over Limit dB	Read Level dBuV	Factor dB	Remark
1	2469.400	108.20	-----	-----	95.87	12.33	Peak
2	2483.800	63.03	74.00	-10.97	50.62	12.41	Peak

Note:
 1. Level = Read Level + Factor
 2. Factor = Antenna Factor + Cable Loss - Preamp Factor
 3. Over Limit = Level - Limit Line
 4. The peak result complies with AVG limit, AVG result is deemed to comply with AVG limit.
 5. The other emission levels were very low against the limit.

Site :HC-C802
 Condition :3m Horizontal
 Mode :n20_TX_2462MHz
 Test By :Gary

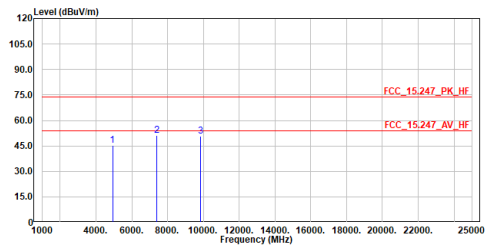

No.	Frequency MHz	Level dBuV/m	Limit Line dBuV/m	Over Limit dB	Read Level dBuV	Factor dB	Remark
1	4924.000	45.42	74.00	-28.58	59.70	-14.28	Peak
2	7386.000	51.21	74.00	-22.79	59.00	-7.79	Peak
3	9848.000	50.73	74.00	-23.27	54.81	-4.08	Peak

Note:
 1. Level = Read Level + Factor
 2. Factor = Antenna Factor + Cable Loss - Preamp Factor
 3. Over Limit = Level - Limit Line
 4. The peak result complies with AVG limit, AVG result is deemed to comply with AVG limit.
 5. The other emission levels were very low against the limit.

Site :HC-C802
 Condition :3m Vertical
 Mode :n20_TX_2462MHz
 Test By :Gary

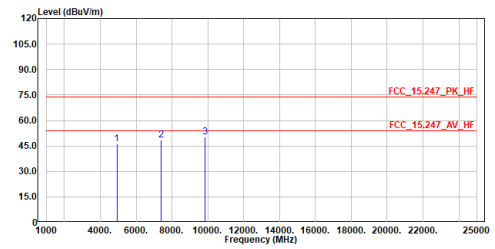

No.	Frequency MHz	Level dBuV/m	Limit Line dBuV/m	Over Limit dB	Read Level dBuV	Factor dB	Remark
1	4924.000	46.03	74.00	-27.97	60.31	-14.28	Peak
2	7386.000	48.67	74.00	-25.33	56.46	-7.79	Peak
3	9848.000	50.37	74.00	-23.63	54.45	-4.08	Peak

Note:
 1. Level = Read Level + Factor
 2. Factor = Antenna Factor + Cable Loss - Preamp Factor
 3. Over Limit = Level - Limit Line
 4. The peak result complies with AVG limit, AVG result is deemed to comply with AVG limit.
 5. The other emission levels were very low against the limit.

Appendix D. Test Result of Radiated Emissions Co-location

1. WiFi 2.4 GHz + Bluetooth 30 MHz ~ 1 GHz:

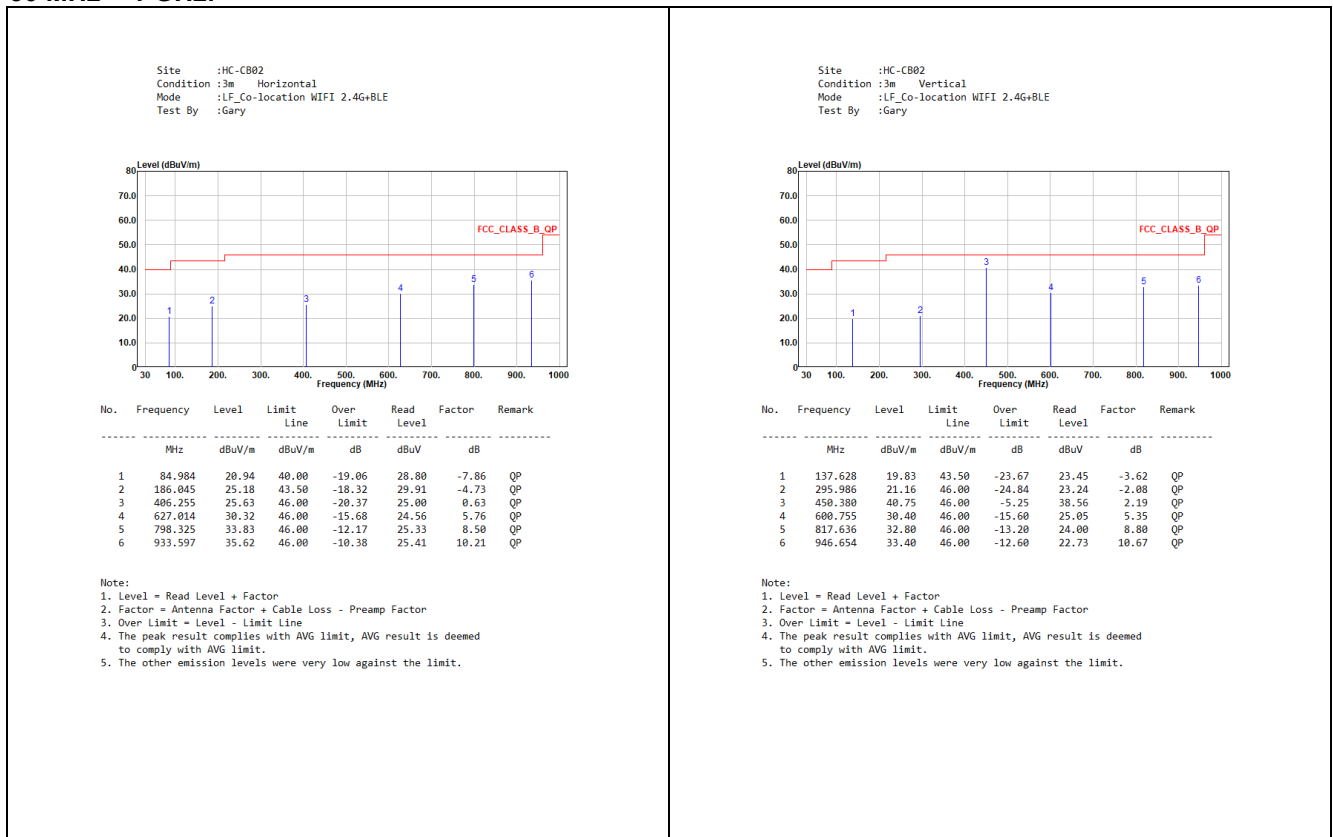

Above 1 GHz:



2. WiFi 5 GHz + Bluetooth 30 MHz ~ 1 GHz:

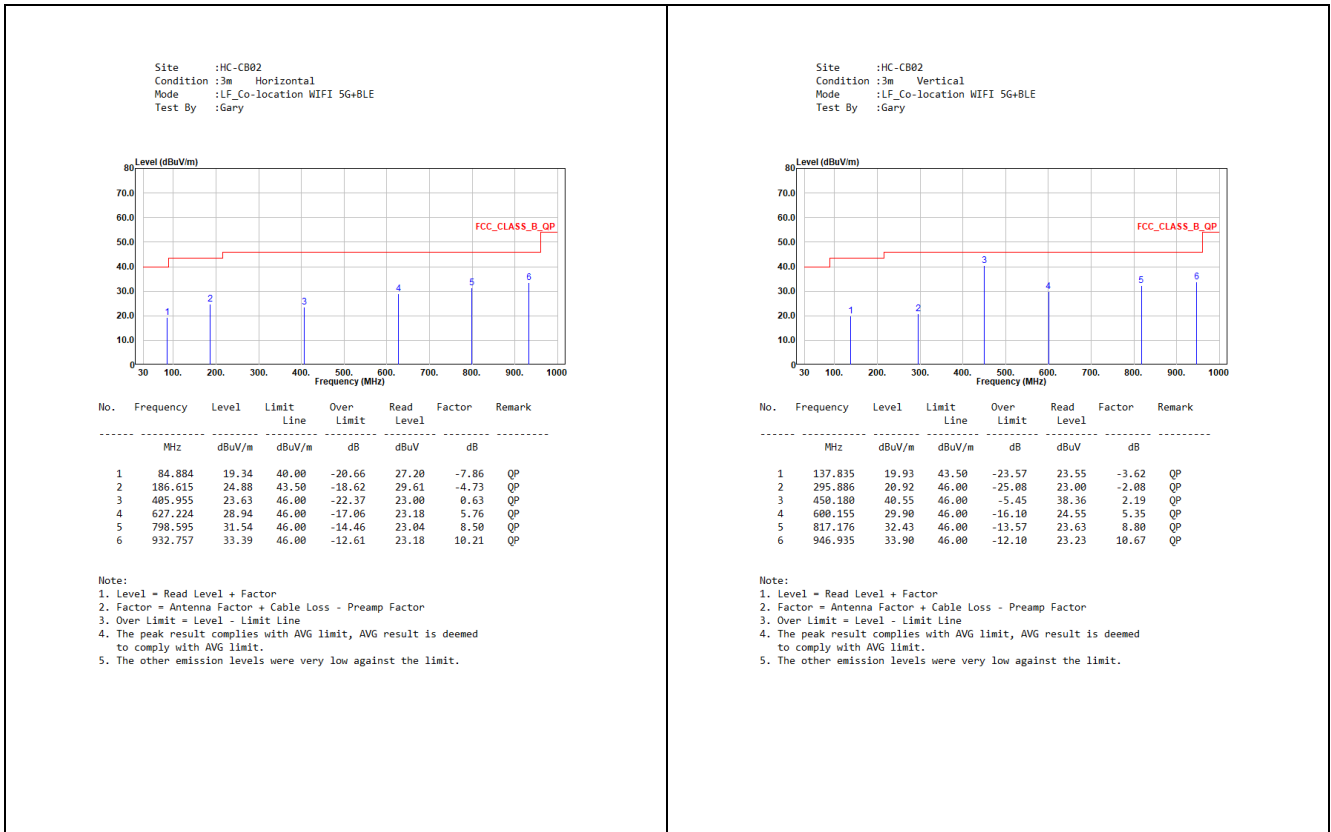

Above 1 GHz:

