

FUNCTION

Model menu

Save various settings as model memories Up to 20 model memories can be named and stored.

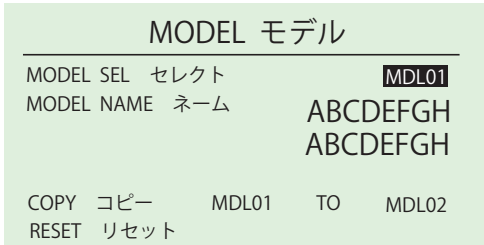

▶ MODEL SEL

Switch between different model memories.

▶ MODEL NAME

Names the model memories.

▶ MODEL COPY

Copies model memories.

▶ MODEL RESET

Resets model memories.

▶ MODEL SEL

Switch between different model memories.

[Example]

If you have multiple cars, it is convenient to have a separate model memory for each one. Even in the case of only one car, you could save specific settings for different courses as different model memories as well.

Select the model to be used.

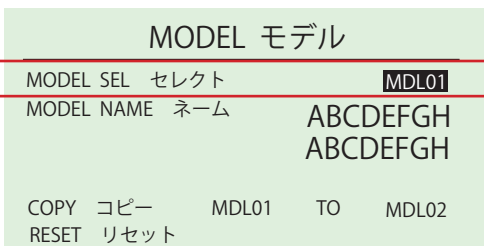

[Setting Range] MODEL:01 - 20 Setting

P All of the various settings are registered under a model memory.

P The settings which will be switched by Model Select are...

- 1)Steering Setting
- 2)Throttle Setting
- 3)3CH Setting
- 4)4CH Setting
- 5)Steering and Throttle Response
- 6)Steering and Throttle Feel
- 7)Setup Functions (ET1-ET5, BT1 function assignments)
- 8)Stopwatch Settings

! Switching model memory while driving may cause setting mismatches and lead to an uncontrollable model. Please place the car on a stand or switch it off before switching model memories.

! Model selection changes and modulation mode changes are not linked. Refer to p.24 changing the modulation mode.

▶ MODEL NAME

This function is used to name the model memory that is currently in use. Distinguish each model memory with different names, which may also be edited. The set model name will be displayed on the initial screen and model select screen.

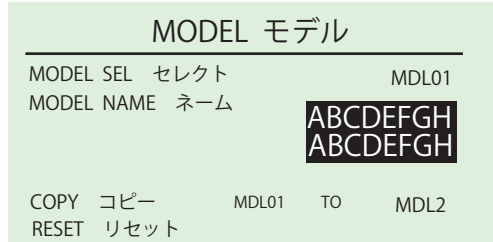

Choose one character at a time from the left side.

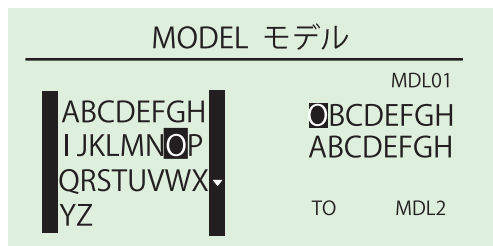

[Setting Range] 40Setting Range Maximum 16 characters.

[Selectable Characters]

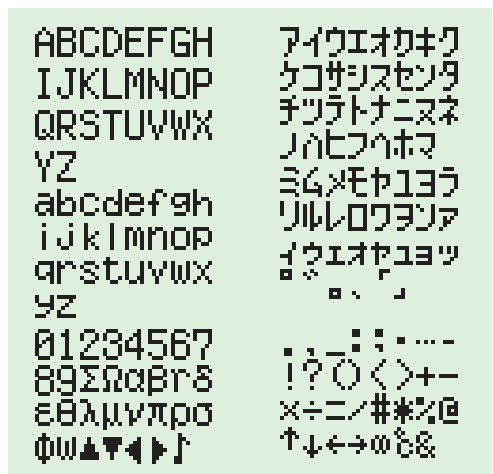

P To delete a character, overwrite the character to be deleted by using the blank space at the end of each page of characters.

▶ MODEL COPY

Copies the current model memory to a different model memory.

[Example]

When changing settings on the same car to match driving conditions, it is convenient to copy the original memory before modifying it. This function also allows you to try out new settings while keeping your original one.

Select the model memory to copy to, then hold the ENTER key to copy.

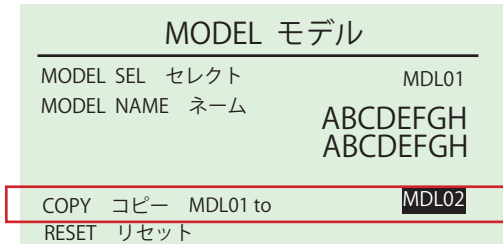

Small window [COPY OK?] appears, then push the ENTER key.

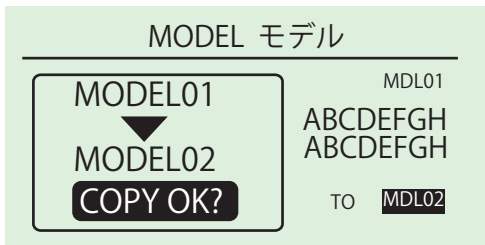

[Setting Range] MODEL:01 - 10Setting

- P** When selecting the model memory to copy to, that model memory's name will be displayed.
- P** The settings which will be switched by Model Select are...
 - 1)Steering Setting
 - 2)Throttle Setting
 - 3)3CH Setting
 - 4)4CH Setting
 - 5)Steering and Throttle Response
 - 6)Steering and Throttle Feel
 - 7)Setup Functions (ET1-ET5, BT1 function assignments)
 - 8)Stopwatch Settings

! The contents of the model memory that is being copied to will be overwritten. Overwritten data cannot be recovered, so be careful to avoid undesired memory overwrites.

▶ MODEL RESET

Return the current model memory to default factory setting values.

Select [RESET] (hold ENTER key) to reset.



Small window [RESETOK?] displayed, then push the ENTER key.

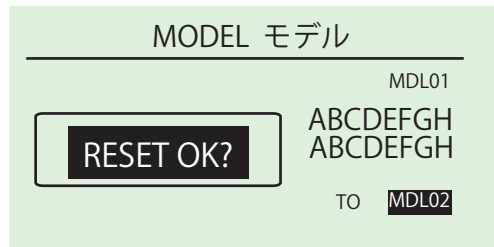

! Deleted data cannot be recovered. Be careful to avoid undesired resets.

TIMER Menu

Operating Timer-related functions.

《Functions》

▶ TRGSTART Trigger Start

Prepares the stopwatch for activation via the throttle movement.

▶ LAP HISTORY

Displays the lap times recorded by the stopwatch.

▶ ALARM

Alarm will sound after the set amount of time has elapsed.

ALARM STOP

Sets an alarm buzzer to the continue sound mode (CONTINUE) or to the sound stop mode(STOP).

P.ALAM

Sets a warning buzzer to sound at a set time prior to the alarm.

NAVI

Adjusts the lap navigation settings.

START/STOP

Assigns a key to activate/deactivate the stopwatch. (Required)

LAP

Assigns a lap key.

FUNCTION セット		
MODEL モデル	TIMER タイマー	KEYSET キーセット
3-4CH	TRMSET トリグセット	SYSTEM システム

▶ TRGSTART Trigger Start

Move the cursor to [TRGSTART] and hold the ENTER key. TRGSTART will switch to READY for a brief moment, then push assigned [START/STOP]key or move throttle trigger.

TIMER タイマー	
TRGSTART	LAPHISTORY
ALARM	5MIN STOP
P. ALM	10SEC
NAVI	00300
START/STOP	OFF
LAP	OFF

P When the [START/STOP] key is set to OFF, it does not activate.

▶ LAP HISTORY

Displays the lap times recorded by the stopwatch. Scroll down when the R key is pushed, and scroll up the L key is pushed. When pressing the BACK key, you are returned to the Timer screen.

LAPHISTORY ラップキログ	
001	00' 02" 20
002	00' 05" 51
003	00' 05" 09
004	00' 04" 72
005	00' 02" 70
TTL	00' 20" 25

P 100 lap times are memorized.

! Only the last recorded lap times may be checked and previously recorded results will not be saved. (Even if the transmitter is switched off, the last recorded times will remain in the memory.)

▶ ALARM

Move the cursor to setting the various parameters.

TIMER タイマー	
TRGSTART	LAPHISTORY
ALARM	5MIN STOP
P. ALM	10SEC
NAVI	00300
START/STOP	OFF
LAP	OFF

【Setting Range】 MIN (minute) SEC (second)

ALARM

: 1 MIN ~ 99 MIN (Default : 5 MIN)

Alarm will sound after the set amount of time has elapsed.

* Convenient for setting the anticipated race completion time.

ALARMSTOP

: STOP / CONT (Default : STOP)

Sets an alarm buzzer to the continue sound mode (CONTINUE) or to the sound stop mode(STOP).

* STOP Buzzer sound stop about 5 seconds.

* CONT Until the START/STOP key is pressed the Buzzer sound will continue.

P.ALAM

: 0 ~ 30 SEC (Default : 10 SEC)

Sets a warning buzzer to sound at a set time prior to the alarm.

* Convenient for setting a warning for when a race is about to end.

NAVI

: 0 SEC 00 ~ 99 SEC 99 (Default : 0 SEC 00)

Adjusts the lap navigation settings.

* Convenient for setting a target lap.

START/STOP

: OFF, ET1 ~ 5, BT1 (Default : OFF)

Assigns a key to activate/deactivate the stopwatch. (Required)

LAP

: OFF, ET1 ~ 5, BT1 (Default : OFF)

Assigns a lap key.

! Configuration of the Timer function, settings aside from switching [START/STOP] to OFF are required.

KEYSET Key setting

Assign a key (ET1- ET5, BT1) to a function.

FUNCTION セットイ		
MODEL モデル	TIMER タイマー	KEYSET キーセットイ
3・4CH	TRMSET トリムセット	SYSTEM システム

If you select a key, the item is displayed to the right. It is assigned to a key by choosing an item.

KEYSET キーセットイ		
ET 1 : S : TRIM	OFF	
ET 2 : T : TRIM	S : TRIM	
ET 3 : T: BRAKE	S : TRAVEL	
ET 4 : S: TRAVEL	S : FEEL	
ET 5 : OFF	T : TRIM	
BT 1 : OFF	T : HIPOINT	

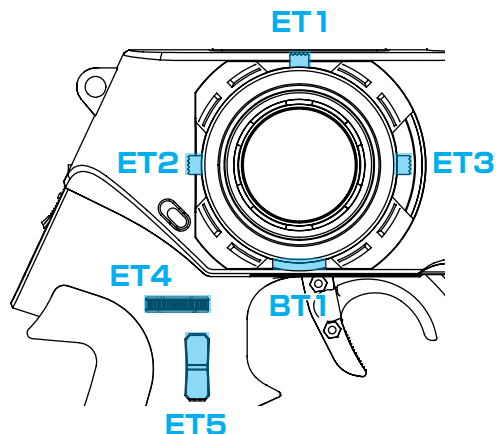

※ To use (ET4, ET5), No.10526 Expert grip is required.

[Setting Range] ○ : Assignment Possible

設定機能	ET1 ~ 5	BT1
OFF (No Assignment)	○	○
S:TRIM (Steering Trim)	○	x
S:TRAVEL (Steering Travel)	○	x
S:FEEL (Steering Feel)	○	x
T:TRIM (Throttle Trim)	○	x
T:HIPOINT (Throttle High Point)	○	x
T: BRAKE (Throttle Brake)	○	x
T:FEEL F (Throttle Feel F)	○	x
T:FEEL B (Throttle Feel B)	○	x
T:OFFSET (Throttle Offset)	○	○
T:OFSTKY (Throttle Offset Key)	○	x
T: BRAKEOR (Throttle Override)	○	○
T:AUTOST (Throttle Auto-Start)	○	○
TIMER (Timer)	○	○
LAPTIME (Lap Time)	○	○

[Default]

ET1 : S:TRIM

ET2 : T:TRIM

ET3 : T: BRAKE

ET4 : OFF

ET5 : OFF

BT1 : OFF

[Non-choice item]

The entry of 3/4CH is displayed only when a key is set to 3/4CH function setting.

3(4) : POS (3・4 CH / Control)

3(4) : SMMODE (3・4 CH / 4WS Mixing Mode)

3(4) : SMCENT (3・4 CH / 4WS Mixing Center)

3(4) : SMTRVL (3・4 CH / 4WS Mixing Travel)

3(4) : AMMODE (3・4 CH / Amp Mixing Mode)

3(4) : AMTH (3・4 CH / Amp Mixing Throttle Hold)

3(4) : TMBRAKE (3・4 CH / Throttle Mixing Brake)

3(4) : TMCENT (3・4 CH / Throttle Mixing Center)

3(4) : TMHIPO (3・4 CH / Throttle Mixing High Point)

3(4) : TMDLAY (3・4 CH / Throttle Mixing Delay)

3(4) : TMSTEER (3・4 CH / Throttle Mixing Steering)

3(4) : TMON (3v CH / Throttle Mixing ON/OFF)

3・4CH 3・4ch Menu

Settings related to 3CH and 4CH operations.

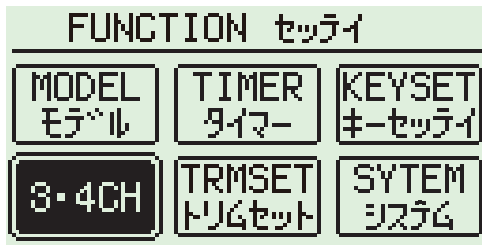

《Functions》

▶ MODE

OFF	GYRO
2WAY	TWIN
3WAY	4WS
5WAY	AMP
ANLOG	T-MIX

▶ SET

Set the usage choice for channels 3 and 4 modes.

The MODE of 3CH or 4CH is selected from the right. Change the setting of the item chosen with the SET key.

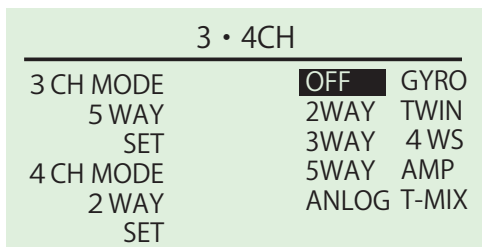

P The functions which may be set are the same for both 3CH and 4CH. Set them to match the desired purpose.

【Default】

3CH MODE : 5WAY
4CH MODE : 2WAY

▶ 2WAY MODE

Modify the 2-interval output settings.

【Example】

May be used to activate/deactivate an engine starter unit or a semi-trailer's support legs.

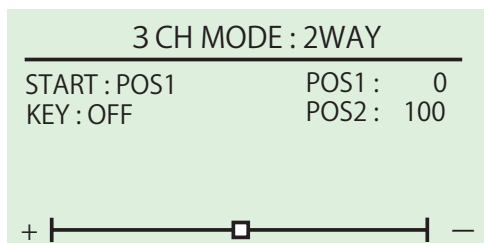

【Setting Range】

START : POS 1、POS 2 (Default : POS 1)

Sets the starting position.

KEY : OFF、ET1 ~ 5 (Default : OFF)

Assigns a key to use for switching positions.

POS 1 : -100 ~ 100 (Default : 0)

Sets Position 1's output position.

POS 2 : -100 ~ 100 (Default : 100)

Sets Position 2's output position.

▶ 3WAY MODE

Modify the 3-interval output settings.

【Example】

May be used for gear changing operations or when you wish to set a 3-interval control scheme for the servo.

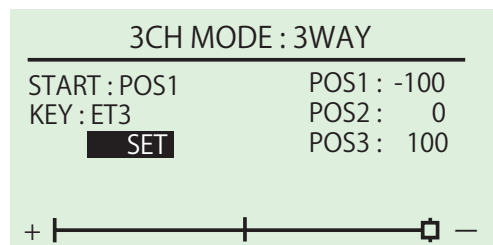

【Setting Range】

START : POS 1、POS 2、POS 3 (Default : POS 1)

Initial position is configured.

KEY : OFF、ET1 ~ 5 (Default : OFF)

Assigns a key to use for switching positions.

POS 1 : -100 ~ 100 (Default : -100)

Sets Position 1's output position.

POS 2 : -100 ~ 100 (Default : 0)

Sets Position 2's output position.

POS 3 : -100 ~ 100 (Default : 100)

Sets Position 3's output position.

▶ 5WAY MODE

Modify the 5-interval output settings.

[Example]

May be used for gear changing operations or when you wish to set a 5-interval control scheme for the servo.

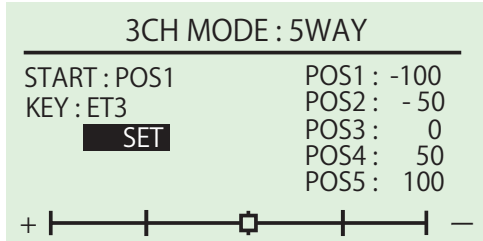

[Setting Range]

START : POS 1, POS 2, POS 3, POS 4, POS 5
Sets the starting position. (Default: POS 3)

KEY : OFF, ET1 ~ 5, BT1 (Default : OFF)
Assigns a key to use for switching positions.

POS 1 : -100 ~ 100 (Default : -100)
Sets Position 1's output position.

POS 2 : -100 ~ 100 (Default : -50)
Sets Position 2's output position.

POS 3 : -100 ~ 100 (Default : 0)
Sets Position 3's output position.

POS 4 : -100 ~ 100 (Default : 50)
Sets Position 4's output position.

POS 5 : -100 ~ 100 (Default : 100)
Sets Position 5's output position.

▶ ANALOG MODE

These settings are to enable continuous output for channels 3 or 4.

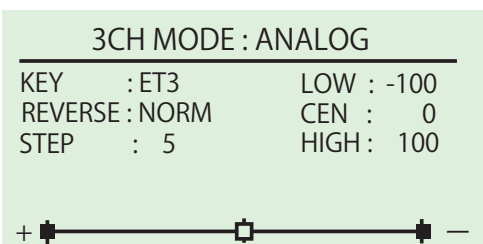

[Setting Range]

KEY : OFF, ET1 ~ 5, BT1 (Default : OFF)
Assigns a key to use for switching positions.

REVERSE : NOR (通常)、**REV** (逆向き) (Default : NORM)
Sets operation direction.

STEP : 1 ~ 25 (Default : 5)
Sets the amount of change for the operation.

LOW (Low Position) : -100 ~ 0 (Default : -100)

Sets the lowest value for the operation range.

CEN (Center Position) : LOW ~ HIGH (Default : 0)

Sets the neutral position for the operation range.

HIGH (High Position) : 0 ~ 100 (Default : 100)

Sets the highest value for the operation range.

[How to Use Analog Settings]

Low Position Side :

Between LOW and CEN are 100 steps within which the intervals can be adjusted.

High Position Side :

Between CEN and HIGH are 100 steps within which the intervals can be adjusted.

Example) When STEP value is 2

When LOW side is set to 5 intervals.
When HIGH side is set to 4 intervals.

Movement Range
Interval Position

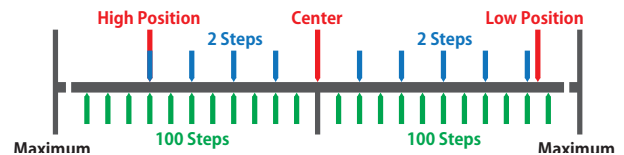

P Center position is the starting position.

P Low/High positions cannot be exceeded. Operations which try to do so will stop just before the Low/High positions.

▶ GYRO MODE

This function modifies the setting for using gyro receiver.

[Example]

When using KR-212FHG Gyro receiver, this function allows for an easy setting.

[How to set Gyro mode]

GYRO is configured to channels 3/4 control modes.

ET3 : 3ch control (Steering gyro gain control)

ET5 : 4ch control (Throttle gyro gain control)

Adjust it to moderate gyro gain while running.

P Specification of channel 3 and 4 of the gyro mode memory (storage) is memorized.

! The functions which may be set are both 3CH and 4CH.

! When the 3ch/4ch mode is changed from GYRO mode to another mode or OFF, the 3ch mode will return to the setting for (OFF).

! Please prepare the gyro system (ex. KR-212FHG) separately. The gyro effect is not provided only in the main system of transmitter.

▶ TWIN SERVO MODE

This function modifies the setting for using 2 steering servo. Using left steering servo 1ch, and right steering servo 3ch or 4ch.

[Example]

Ackerman control is possible when using for drift cars using twin servos.

3CH MODE : TWIN SERVO			
LEFT — ST (1 CH)		RIGHT — ST NORM	
L • LEFT	70%	R • LEFT	70%
L • RIGHT	70%	R • RIGHT	70%
L • SPEED	100%	R • SPEED	100%
L • TRIM	0	R • TRIM	0

[Setting Range]

LEFT-ST (1CH)

L-LEFT : 30 ~ 100% (Default: 70%)

Sets the highest value for the 1CH servo left operation.

L-RIGHT : 30 ~ 100% (Default: 70%)

Sets the highest value for the 1CH servo right operation.

L-SPEED : 1 ~ 100% (Default: 100%)

Sets the steering speed for the 1CH servo operation.

L-TRIM : -50 ~ 50 (Default: 0)

Sets the neutral position for the 1CH servo operation range.

RIGHT-ST

NORM (Normal)、REVS (Reverse) (Default: NORM)

Sets operation direction of 3CH or 4CH servo.

R-LEFT : 30 ~ 100% (Default: 70%)

Sets the highest value for the 3(4)CH servo left operation.

R-RIGHT : 30 ~ 100% (Default: 70%)

Sets the highest value for the 3(4)CH servo right operation.

R-SPEED : 1 ~ 100% (Default: 100%)

Sets the steering speed for the 3(4)CH servo operation.

R-TRIM : -50 ~ 50 (Default: 0)

Sets the neutral position for the 3(4)CH servo operation range.

▶ 4WS

This function is related to an R/C car's 4-wheel steering feature. If 3CH or 4CH is assigned to control the rear axle, it will operate in conjunction with 1CH (steering). The direction of the rear axle steering may also be changed.

3CH MODE : 4 WS	
MODE	NORMAL ->KEY:OFF
LEFT	70
CENTER	0 ->KEY:OFF
RIGHT	70
TRVL	100 ->KEY:OFF
REVERSE	NORM

[Setting Range]

MODE (Default: NORMAL)

NORMAL (front and rear axles turn in the same direction)

REVERSE (front and rear axles turn in opposite directions)

F STEER (steer front axle only)

R STEER(steer rear axle only)

LEFT : 0 ~ 100 (Default: 70)

Adjusts the rear axle servo movement range when steering is turned to the left.

CENTER : -50 ~ 50 (初期値 : 0)

Adjust the rear axle servo's neutral position.

RIGHT : 0 ~ 100 (Default: 70)

Adjusts the rear axle servo movement range when steering is turned to the right.

TRAVEL : 0 ~ 150 (Default: 100)

Adjusts the overall amount of movement of the rear axle servo when the steering is at full lock.

REVERSE : NORM (Normal)、REVS (Reverse) (Default: NORM)

Sets operation direction of 3CH or 4CH servo.

MODE → KEY : OFF、ET1 ~ 5 (Default: OFF)

Assigns ET keys to be used for 4WS Mixing MODE.

CENTER → KEY : OFF、ET1 ~ 5 (Default: OFF)

Assigns ET keys to be used for 4WS Mixing CENTER.

TRVEL → KEY : OFF、ET1 ~ 5 (Default: OFF)

Assigns ET keys to be used for 4WS Mixing TRAVEL.

▶ AMP Mixing MODE

Used when the front and rear wheels are controlled by separate ESCs and motors. If 3CH or 4CH is set to the front-wheel drive function, it will operate in conjunction with 2CH's throttle operations.

3CH MODE : AMP		
MODE	NORMAL	->KEY:OFF
TH HOLD	0	->KEY:OFF
HIPOINT	100	->KEY:OFF
BRAKE	100	->KEY:OFF
TRIM	0	
REVERSE NORM		->KEY:OFF >>>

[Setting Range]

MODE (Default: NORMAL)
 NORMAL(drives both front and rear wheels)
 BURN(drives rear wheels only)
 DIG(drives front wheels only)
 F HOLD(drives front wheels at a set speed)
 R HOLD(drives rear wheels at a set speed)

TH HOLD : -100 ~ 100 (Default: 0)

This function adjusts the set speed used for (F HOLD) and (R HOLD) selected in Amp Mixing Mode.[F HOLD] adjusts the front wheel drive while [R HOLD] adjusts the rear wheel drive.

※ This setting is activated when F HOLD or R HOLD mode is selected.

[Example] May be used for rock crawlers, etc.

HIPOINT : 0 ~ 150 (Default : 100)

Adjusts the maximum amount of throttle to be applied to the front wheels. Equivalent to the [Throttle High Point] function.

※ This setting is activated when NORMAL, DIG, or R HOLD mode is selected.

P This makes it easy to adjust the amount of maximum throttle, particularly on a glow engine car.

P If the amp mixing high point is set low and the amp mixing trim is set to a high value toward acceleration, the resulting throttle movement may be extraordinarily small.

! On glow engine cars, an overly high setting value will increase load on the servo and lead to it being damaged. Check carefully while adjusting.

! On electric cars, a setting value that is too small may cause problems with the ESC settings. Make adjustments starting from the default setting (100).

! Brake will not operate if the value is set to 0.

BRAKE : 0 ~ 150 (Default: 100)

Modify the maximum amount of reverse (brake) to be applied to the front wheels.

Equivalent to [Throttle Brake] function.

※ This setting is activated when NORMAL, DIG, or R HOLD mode is selected.

! On glow engine cars, an overly high setting value will increase load on the servo and lead to it being damaged. Check carefully while adjusting.

! On electric cars, a setting value that is too small may cause problems with the ESC settings. Make adjustments starting from the default setting (100).

! Brake will not operate if the value is set to 0.

TRIM : -50 ~ 50 (Default : 0)

Adjusts the neutral position of the front wheels.

P The setting position cannot exceed what is set by [High Point] or [Brake].

REVERSE : NORM (Normal)、REVS (Reverse)
 Changes the movement direction of the front wheels. (Default: MORM)

P For electric cars, the throttle is set by the ESC so there is no need to set this function. However, some older ESCs will not function properly unless reverse is also set.

MODE → KEY : OFF、ET1 ~ 5 (Default : OFF)

Assigns ET or BT keys to activate the various front wheel drive modes.

TH HOLD → KEY : OFF、ET1 ~ 5 (Default : OFF)

Assigns ET keys to be used for the set speed used for TH HOLD.

HIPOINT → KEY : OFF、ET1 ~ 5 (Default : OFF)

Assigns ET or BT keys to adjust HIPOINT value.

BRAKE → KEY : OFF、ET1 ~ 5 (Default : OFF)

Assigns ET or BT keys to adjust BRAKE value.

REVERSE → KEY : OFF、ET1 ~ 5 (Default : OFF)

Assigns ET or BT keys to changes the movement direction of the front wheels.

[Setting Range]

ET MODE SET

Assigns ET or BT keys to activate the various front wheel drive modes.

3CH MODE:AMP	
ET MODE SET	
NORMAL	: ON
BURN	: ON
DIG	: ON
F HOLD	: ON
R HOLD	: ON
<<<	

NORMAL : ON、OFF (Default : ON)

BURN : ON、OFF (Default : ON)

DIG : ON、OFF (Default : ON)

F HOLD : ON、OFF (Default : ON)

R HOLD : ON、OFF (初期値 : ON)

P Assigning these keys may be convenient for rock crawlers or when you need to adjust Amp Mixing settings.

▶ T-MIX Throttle Mixing MODE

Mainly used for 1/5 scale R/C cars where the left/right front wheels' braking operation is controlled by an independent servo.
 If 3CH is assigned to front right wheel brake and 4CH is assigned to front left wheel brake, they will operate in conjunction with 2CH (throttle) and 1CH (steering).

[Example]

Simplifies adjustment of the independent brake channel (servo) on 1/5 scale R/C cars.

3CH MODE : T-MIX		
BRAKE	100	->KEY:OFF
CENTER	0	->KEY:OFF
HIPOINT	100	->KEY:OFF
DELAY	0	->KEY:OFF
STEER	0	->KEY:OFF
ON/OFF	ON	->KEY:OFF >>>

[Setting Range]

- BRAKE : 0 ~ 150 (Default : 100)**
 Modify the maximum amount of front brake servo movement.
- CENTER : -50 ~ 50 (Default : 0)**
 Modify the front brake servo's neutral position.
- HIPOINT : 0 ~ 150 (Default : 100)**
 Modify the maximum amount of throttle to be applied to the front brake servo.
 ※ To avoid operating only the brakes, set value to 0.
- DELAY : 0 ~ 100 (Default : 0)**
 Delays the operation of the front wheel servo brake.
- STEER : -100 ~ 100 (Default : 0)**
 Modify the amount of brake applied by the front wheel brake servo in relation to steering input.
- ON/OFF : ON, OFF (Default : ON)**
 Enables Throttle Mixing to be activated via ET keys.
- BRAKE → KEY : OFF, ET1 ~ 5 (Default : OFF)**
- CENTER → KEY : OFF, ET1 ~ 5 (Default : OFF)**
- HIPOINT → KEY : OFF, ET1 ~ 5 (Default : OFF)**
- DELAY → KEY : OFF, ET1 ~ 5 (Default : OFF)**
- STEER → KEY : OFF, ET1 ~ 5 (Default : OFF)**
- ON/OFF → KEY : OFF, ET1 ~ 5 (Default : OFF)**

! These setting must be set for both front right brake (3CH) and front left brake (4CH).

3CH MODE : T-MIX

FOWARD CURVE: 0%
 BRAKE CURVE: 0%

REVERSE : NORM

<<<

[Setting Range]

FORWARD CURVE : -100% ~ 100% (Default : 0%)
BRAKE CURVE : -100% ~ 100% (Default : 0%)

P Positive values (+1 to +100) equal high initial response followed by mild response.
 Negative values (-1 to -100) equal a mild initial response followed by high response.

REVERSE : NORM, REVE (Default : NORM)

This function reverses the front brake servo's movement direction. It is useful for when servo output movement does not match inputs after the servo has been installed.

! Use of Throttle Mixing Steering may increase load on the servo and cause increased wear or damage. Check the servo while adjusting.

TRIM SET

The convenient function that can set trim and travel while operating steering wheels.

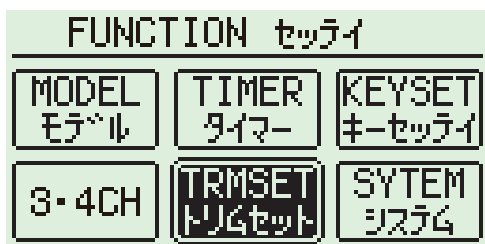

▶ STEER AUTO TRIM

- ① Move the cursor to "SET" and push the ENT key, "SET" will start blinking.
※ At this time, the steering trim becomes 0 forcibly.
- ② Hold the steering wheel of the transmitter to the position that you want to make neutral. Set the steering neutral position by pushing the ENT key while holding the position.



- P** As for this function, only the numerical value of the steering trim changes. Does not influence the numerical value of the steering subtrim.
- !** After pushing "SET", the steering servo moves because the neutral position has changed. Release the steering handle, the servo moves to the new neutral position.

▶ STEER AUTO BALANCE LEFT

- ① Move the cursor to "SET" and push the ENT key, "SET" will start blinking.
※ At this time, the steering travel(L) becomes 100 forcibly.
- ② Hold the steering wheel of the transmitter to the position that you want to make the Left end point. Set the steering travel(L) position when pushing the ENT key while holding the position.

P As for this function, only the numerical value of the steering travel(L) changes. Does not influence the numerical value of the steering travel and travel(R). When the quantity of movement is short, set automatic balance again after increasing steering travel.

! After pushing "SET", the steering servo moves because the travel(L) position has changed. Release the steering handle, the servo moves to the neutral position.

! Use of Steering auto balance may increase load on the servo and cause increased wear or damage. Check the servo while adjusting.

! When operating the steering wheel to the right in steering auto balance(L), it will not set correctly. Be careful to the direction of operation.

▶ STEER AUTO BALANCE RIGHT

- ① Move the cursor to "SET" and push the ENT key, "SET" will start blinking.
※ At this time, the steering travel(R) becomes 100 forcibly.
- ② Hold the steering wheel of the transmitter to the position that you want to make the Right end point. Set the steering travel(R) position when pushing the ENT key while holding the position.

P As for this function, only the numerical value of the steering travel(R) changes. Does not influence the numerical value of the steering travel and travel(L). When the quantity of movement is short, set automatic balance again after increasing steering travel.

! After pushing "SET", the steering servo moves because the travel(R) position has changed. Release the steering handle, the servo moves to the neutral position.

! Use of Steering auto balance may increase load on the servo and cause increased wear or damage. Check the servo while adjusting.

! When operating the steering wheel to the left in steering auto balance(R), it will not set correctly. Be careful to the direction of operation.

SYSTEM MENU

Menu related to various system settings.

FUNCTION セッテイ		
MODEL モデル	TIMER タイマー	KEYSET キーセッテイ
3-4CH	TRMSET トリムセット	SYSTEM システム

SYSTEM システム		
DISPLY ゲーム	BATTERY バッテリー	CULC. ケイサンキ
SOUND サウンド	VRINFO VRインフォ	KEYSPD キーソフト

▶ DISPLAY MENU

Setting about LCD display.

DISPLAY ガメン		
CONTRAST ノウド		4
LIGHTMODE バックライト	KEY-ON	
LIGHTTIME ライトタイム		5

[Setting Range]

CONTRAST : 1 ~ 5 (Default : 4)

Adjusts the contrast of the LCD.

LCD levels become light when the numerical value is reduced.

- P** LCD contrast will characteristically be darker when warm and lighter when cold. Make corresponding contrast adjustments if this is a concern for you.

LIGHTMODE

Backlight mode of the LCD : OFF、ON、KEY-ON

Sets the light activation mode.(Default: KEY-ON)

LIGHTTIME : 1 ~ 60 (Default: 5)

Sets the time between a key operation (other than steering or throttle) and the LCD turning off when [LIGHT MODE] is set to [KEY-ON].

- !** When the backlight is set to [KEY-ON], it will only be activated by ET/BT key operation, not by steering or trigger operation.

▶ BATTERY

Select the type of battery used.

BATTERY バッテリー	
DRY カンデ ンチ	LIFE リフェ
NI-MH ニッケル	LIPO リポ

[Setting Range]

DRY(Alkaline Batteries),

Primary warning buzzer 4.0V or less

Second warning buzzer, movement stop 3.8V or less
LIFE(Li-Fe Battery)

Primary warning buzzer 6.2V or less

Second warning buzzer, movement stop 6.0V or less

NI-MH(Ni-MH Battery)

Primary warning buzzer 4.0V or less

Second warning buzzer, movement stop 3.8V or less

LIPO(Li-Po Battery)

Primary warning buzzer 7.0V or less

Second warning buzzer, movement stop 6.0V or less

- P** According to the selected power source type, a low voltage warning will be displayed. Transmitter signals will not be cut at this time, but problems with control may be experienced. Stop operation immediately and replace batteries.

- P** When setting a battery type by mistake, the warning message can be canceled by pushing and holding the BACK key to display the initial screen. Please set it to right battery again.

! Change Power Management After Switching Battery Type!

If the battery used does not match the Power Management setting, the battery may be over-discharged and damaged. This may also result in fire, so make sure you pay special attention.

! WARNING ! Warning Display

▶ Battery Level Warning

During driving, this warning will be displayed if the battery voltage is below the required level.

You may still operate the model, but it is recommended to replace the battery immediately

※ In the case of DRY/Ni-MH setting, the LED (blue) of the main body of EX-2 flashes on and off, too.

BATTERY WARNING

LOW VOLTAGE

EXIT >> KEY ON

Furthermore, when the power supply voltage decreases, it is displayed and normal operation will not be able to continue. Switch it off immediately, and replace the batteries immediately.

BATTERY ALARM

LOW VOLTAGE

EXIT >> POWER OFF

▶ CALCULATOR

calculate the gear ratio.

CALCULATOR ケイサンキ			
SPUR GEAR スパ -	110	FINAL RATIO ギヤレ 7.333	
PINION GEAR /ピニオン	30		
TRANSRATIO x2ジケンソク	2.00		

[Setting Range]

SPUR GEAR : 1 ~ 999 (Default : 110)
 PINION GEAR : 1 ~ 999 (Default : 30)
 TRANSRATIO : 1.00 ~ 99.99 (Default : 2.00)

[How to use]

When the spur, pinion and transmission ratio are inputted, the gear ratio is automatically calculated and shown in the picture right side of the displays.

▶ SOUND

Adjusts the sound level of the transmitter buzzer.

SOUND サウンド	
BUZZER TONE オンテイ	2
BUZZER PATTERN パターン	1
BUZZER VOLUME ボリューム	5

[Setting Range]

BUZZER TONE : 1 ~ 7
 (Default : 2)
 BUZZER PATTERN : 1 ~ 7
 (Default : 1)
 BUZZER VOLUME : 0 ~ 5
 (Default : 5)

▶ VR INFORMATION

Adjust the potentiometer of the steering and throttle.

※ Please set it by all means.

- When using EX-2 for the first time.
- When changing a steering unit for a different product or when putting it back together.
- When changing a grip unit for a different product or when putting it back together.
- When changing a grip unit for a different product or when putting it back together.

- 1, Select [FUNCTION] on the initial screen and push the ENTER key.
- 2, Select [SYSTEM] on the function screen and push the ENTER key.

- 3, Select [VR INFO] on the system screen and push the ENTER key.
- 4, Move the wheel slowly to the full left and right lock (numbers will change as the steering is moved) and release the wheel back to neutral.
- 5, Move the trigger slowly to the full throttle and full brake positions (numbers will change as the throttle is moved) and release the trigger back to neutral.
- 6, Select the "YES" on the right side of the display screen.

3, Example before setting

VR INFORMATION	VRインフォメーション	
ST- LEFT	ヒタリ	2204
NUT	センター	2198
RIGHT	ミギ	2194
TH- HI	ゼンシン	2078
NUT	センター	2075
LOW	ブレーキ	2072

OK?
YES

4,5, Move slowly to full stroke, then release.

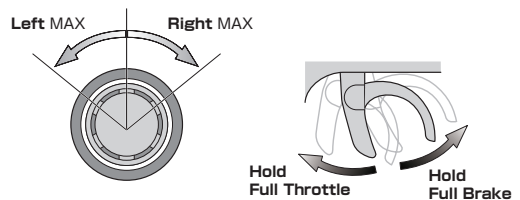

6, Small window [Yes] comes active.

VR INFORMATION	VRインフォメーション	
ST- LEFT	ヒタリ	3949
NUT	センター	2198
RIGHT	ミギ	487
TH- HI	ゼンシン	3313
NUT	センター	2075
LOW	ブレーキ	1463

OK?
YES

※ When operating the VR INFORMATION and pressing the BACK key will cancel the operation.

⚠ Do not operate steering wheel and throttle trigger while pressing ENTER, as this may change the data values and affect subsequent operations. If this function is not adjusted properly, improper operation may result.

⚠ VR Information timing may vary depending on usage. If problems persist even after using VR Information, contact KO Propo Customer Service Department to arrange repairs. (We recommend that you contact KO Propo Customer Service Department if you are not sure what the problem is.)

▶ KEYSPEED

Adjusts the delay between operations if the ET/BT key is pressed repeatedly.

KEYSPEED キーソクド	
KEYSPEED キーソクド	3
MENUSPEED メニューソクド	3

[Setting Range]

KEYSPEED : OFF ~ 5

(Default : 3)

MENUSPEED : OFF ~ 5

(Default : 3)

 OFF:Key Repeat Disabled.
The larger value will shorten the delay time.

 The ET/BT keys speed is fixed and can not be independently changed.

▶ OPERATION ALARM

When there is no input to the transmitter in over three minutes, the EX-2 alarm will sound. The alarm is canceled when operating steering wheel, throttle trigger, ET, BT key, ENT key, L R key, BACK key.

※ This function setting can not be changed nor turned off.

STEERING

TRAVEL

Modify the overall amount of steering movement.

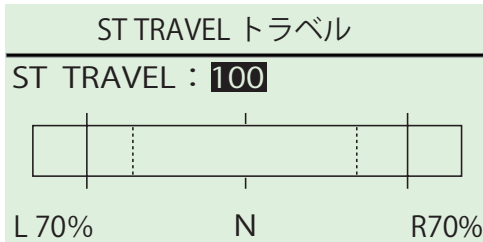
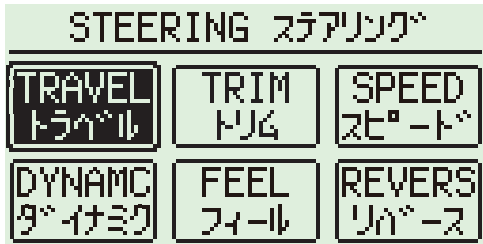

▶ ST TRAVEL

Modify the overall amount of steering movement.

▶ L (BALANCE)

Modify the left steering angle end point.

▶ R (BALANCE)

Modify the right steering angle end point.

▶ ST TRAVEL Steering Travel

Adjust the overall amount of steering servo movement when the steering wheel is at full lock.

[Setting Range]

ST TRAVEL : 0 ~ 150
(Default : 100)

P Since the Balance setting value is a ratio of the Travel setting value, if the latter is modified the actual movement value and the displayed graphic will also change.(the Travel value will not change).

A Steering will not operate if the Travel value is set to 0.

▶ ST BALANCE L R Steering BalanceL R

Adjust the left/right steering angles independently. This enables the turning radii to match up during cornering.

[Setting Range]

ST BALANCE L : 30 ~ 100
(Default : 70)
ST BALANCE R : 30 ~ 100
(Default : 70)

P The set percentage is a ratio of the value set by the Steering Travel.

P Steering balance can be adjusted by using the steering wheel and ET key!

If an ET key that is assigned to steering trim is pressed while the steering is turned over halfway in either direction, the balance of the direction of the turn can be adjusted.

P If the trim is set to a large value, a large left/right value discrepancy may result. If adjusting steering balance for the first time, follow the procedures below.

- ① Set trim value to 0.
- ② Adjust sub trim so that the car drives in a straight line when steering is in neutral position.
- ③ Use steering travel to match the overall steering angle range.
- ④ Use steering balance to match the left/right turning radii.
- ⑤ If the car does not drive straight at this point, use trim to correct.

TRIM MENU

Adjusts the neutral/center position of the steering angle range.

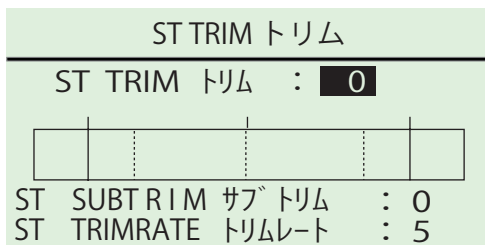
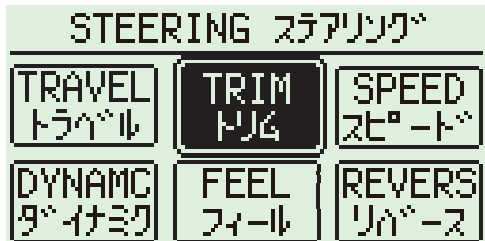

▶ ST TRIM Steering Trim

Modify the neutral position of the steering angle.

▶ ST SUBTRIM Steering Subtrim

Modify the overall steering angle range.

▶ ST TRIMRATE Steering trim rate

Modify the amount of movement which corresponds to one click of the Trim button.

▶ ST TRIM

Adjusts the neutral/center position of the steering angle range.

[Setting Range]

ST TRIM : L50 ~ 0 ~ R50
(Default : 0)

P Setting adjustments prior to driving should be carried out with the sub trim, not the trim.

A The setting range cannot exceed what is set by [Steering Travel] or [Steering Balance].

▶ ST SUBTRIM

Adjust the position of the overall steering angle range. Use this to match the neutral position when installing the steering servo.

※ Also refer to Trim and Sub Trim Operation.(p.17)

[Setting Range]

ST SUBTRIM : L80 ~ 0 ~ R80
(Default : 0)

[Example]

The servo horn position can be adjusted by the linkages, etc. when the servo is installed onto the model, but in case this does not set the neutral position, this function can be used to set it from the transmitter.

P If the sub trim value becomes large, adjust the servo horn position or linkages so that the value becomes closer to 0. If the sub trim value is too large, dead zones could result and the servo may not operate at the extremities of its movement range.

▶ ST TRIMRATE

Adjusts the amount of movement associated with one click of the trim button.

[Setting Range]

ST TRIM RATE : 1 ~ 10
(Default : 5)

P Although the amount of movement of one interval can be adjusted, the lower the number the smaller the amount of movement.

P The overall number of intervals does not change, so a change in trim rate will result in a change in the range in which the trim can be used to make corrections.

P If the trim rate is changed when the trim is already set, the trim may be thrown off. If the trim setting is 0 then this does not apply.)

P Lower trim rates enable fine adjustments, but the effects may not be apparent depending on the servo used. If there is a lot of slop in the linkage or servo saver, fine trim adjustments could cause the user to constantly worry about the trim settings. In that case, please reexamine the linkages, etc

ST SPEED Steering SPEED

Modify the speed of the steering servo movement.

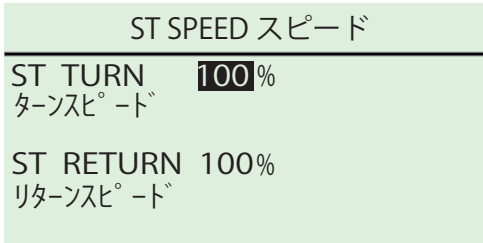
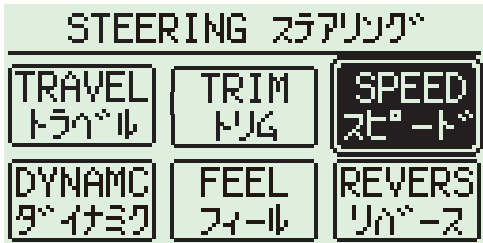

▶ ST TURN Steering Turn Speed

Modify the speed of the steering's turn movement.

▶ ST RETURN Steering Return Speed

Modify the speed of the steering's return movement.

▶ ST TURN Steering Turn Speed

This function limits the maximum speed of the steering servo by adjusting the steering turn direction [TURN] setting.

[Setting Range]

ST TURN SPEED : 1 ~ 100%
(Default : 100%)

[Example]

You can set the speed to be slow during initial turning, then subsequently faster.

- P** Take into account such factors as the servo used, car, driving surface, etc. when adjusting all settings. Conduct test drives to find the best setting values.
- P** Effective speed values are dependent on the speed characteristics of your selected servo.

▶ ST RETURN Steering Return Speed

This function limits the maximum speed of the steering servo by adjusting the steering return direction [RETURN] setting.

[Setting Range]

ST RETURN SPEED : 1 ~ 100%
(Default : 100%)

- P** Take into account such factors as the servo used, car, driving surface, etc. when adjusting all settings. Conduct test drives to find the best setting values.
- P** Effective speed values are dependent on the speed characteristics of your selected servo.

Settings related to steering control.

STEERING ステアリング

TRAVEL トラベル	TRIM トリム	SPEED スピード
DYNAMC ダイナミック	FEEL フィール	REVERS リバース

ST DYNAMICS ダイナミクス

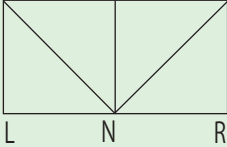

CURVE
カーブ 0%

PUNCH
パンチ 0%

▶ CURVE Steering Curve

Modify the movement speed ratio which corresponds to steering angle.

▶ PUNCH Steering Punch

Modify how much the steering initially turns from neutral position.

▶ CURVE Steering Curve

This function adjusts the ratio of the steering angle to servo movement speed (Curve Characteristics). Choose between (+) Quick Curve and (-) Mild Curve.

[Setting Range]

ST CURVE : -100 ~ 0 ~ 100%
(Default : 0%)

[Example]

Modify the movement speed ratio which corresponds to steering angle.

- P** As the graph shows, servo movement speed can be changed according to wheel movement angle. Positive values (+1 to +100) equal high initial response followed by mild response. Negative values (-1 to -100) equal a mild initial response followed by high response.
- P** When using this in conjunction with other functions such as [Steering Speed], adjust one at a time to confirm their effects to produce an effective overall setting.
- P** To adjust only the steering's initial response, use the [Steering Punch] function.

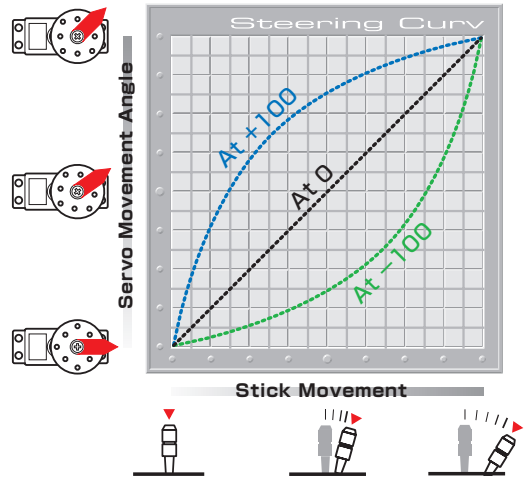

▶ PUNCH Steering Punch

This function quickens the steering's initial response and can be used to instill a strong turning movement when the steering initially moves from neutral.

[Setting Range]

ST PUNCH : 0 ~ 50%
(Default : 0%)

- P** The larger the value, the stronger the amount of turning movement.
- P** This could be effective if steering linkages have a lot of slop, but please note that it does not improve straight-line performance.
- P** When using this in conjunction with other functions such as [Steering Speed], adjust one at a time to confirm their effects to produce an effective overall setting.

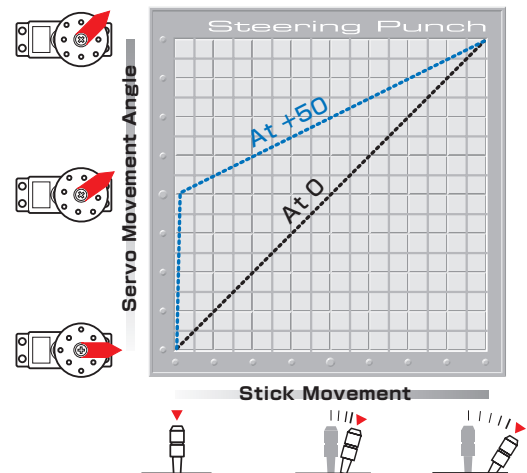

FEEL Steering feel MENU

FEEL function provides changing the moving performance of steering servo.

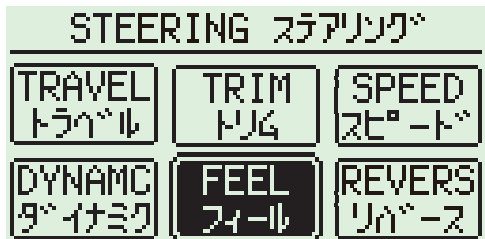

FEEL フィール

ST FEEL
ステアリング フィール **0**
TH FEEL
スロットル フィール F 0
B 0

▶ ST FEEL Steering Feeling

Adjust steering feeling.

▶ TH FEEL F Throttle feel F

Refer to "Throttle Feel F" (p.52)

▶ TH FEEL B Throttle feel B

Refer to "Throttle Feel B" (p.52)

▶ ST FEEL Steering Feel

FEEL function provides changing the cornering performance feeling.

[Setting Range]

ST FEEL : -50 ~ 0 ~ 50%

(Default: 0%)

- P** Take into account such factors as the servo used, car, driving surface, etc. when adjusting Steering feel settings.
Conduct test drives to find the best setting values.

REVERSE Steering Reverse

Modify the steering direction.

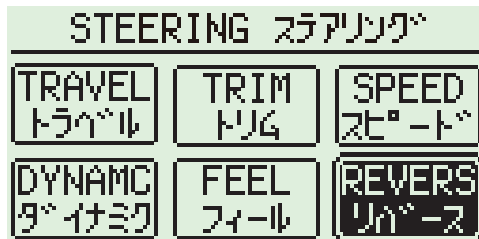

REVERSE リバース

ST REVERSE
ステアリング リバース **NORM**
TH REVERSE
スロットル リバース NORM

▶ ST REVERSE Steering reverse

[Setting Range]

ST REVERSE : NORM (Normal)、REVS (Reverse)
(Default : NORM)

TH REVERSE :

Refer to "Throttle Reverse" (p.53)

- !** Steering direction varies from car to car and should be checked when the R/C equipment has been installed.

THROTTLE

TRAVEL Throttle Travel

Settings related to throttle control.

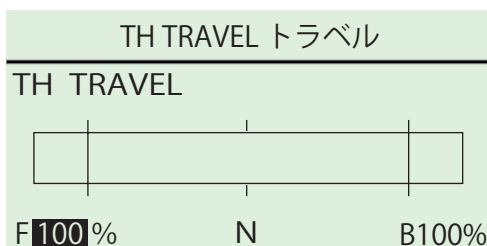
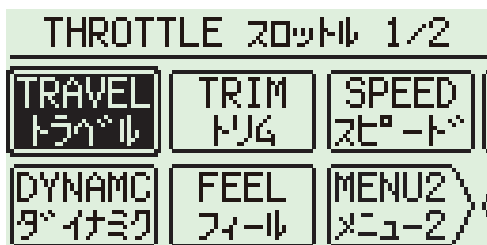

▶ TH TRAVEL F Throttle Travel F

Modify the maximum amount of throttle movement (towards forward acceleration).

▶ TH TRAVEL B Throttle Travel B

Modify the maximum amount of throttle brake movement.

▶ TH TRAVEL F Throttle Travel F

Adjust the maximum amount of throttle forward acceleration movement.

[Setting Range]

TH TRAVEL F : 0 ~ 150
(Default : 100)

- P** The key setting displays [T:HIPOINT].
- P** On glow engine cars, an overly high setting value will increase load on the servo and lead to it being damaged. Check carefully while adjusting.
- P** On electric cars, a setting value that is too small may cause problems with the ESC settings. Make adjustments starting from the default setting (100).
- P** If the throttle travel F is set low and the trim is set to a high value toward acceleration, the resulting throttle movement may be extraordinarily small.

! Throttle will not operate if the High Point value is set to 0.

▶ TH TRAVEL B Throttle Travel B

Adjust the maximum amount of brake movement.

[Setting Range]

TH TRAVEL B : 0 ~ 150
(Default : 100)

- P** The key setting displays [T:BRAKE].
- P** On glow engine cars, an overly high setting value will increase load on the servo and lead to it being damaged. Check carefully while adjusting.
- P** On electric cars, a setting value that is too small may cause problems with the ESC settings. Make adjustments starting from the default setting (100).
- P** If the throttle travel B is set low and the trim is set to a high value braking, the resulting throttle movement may be extraordinarily small.

! Throttle will not operate if the High Point value is set to 0.

TRIM Throttle Trim

Settings related to throttle control.

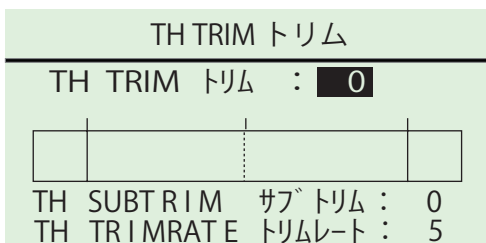
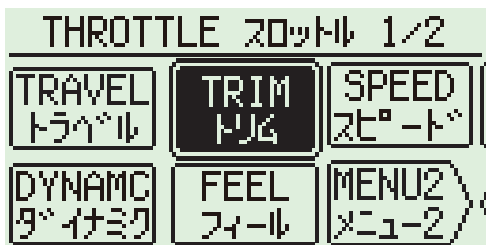

▶ TH TRIM Throttle Trim

Modify the neutral position of the throttle.

▶ TH SUBTRIM Throttle Subtrim

Modify the overall throttle movement range.

▶ TH TRIMRATE Throttle Trimrate

Modify the amount of movement which corresponds to one click of the throttle trim button.

▶ TH TRIM Throttle Trim

Adjusts the neutral/center position of the throttle range.

[Setting Range]

TH TRIM : F50 ~ 0 ~ B50
(Default : 0)

- P** Setting adjustments prior to driving should be carried out with the sub trim, not the trim.
- P** The setting range cannot exceed what is set by [Throttle Travel F] or [Throttle Travel B].

▶ TH SUBTRIM Throttle Subtrim

Adjust the position of the overall throttle movement range. Use this function when the neutral position cannot be centered with only linkage adjustment. Also refer to Trim and Sub Trim Operation. (p.17)

[Setting Range]

TH SUBTRIM : F80 ~ 0 ~ B80
(Default : 0)

[Example]

The servo horn position can be adjusted by the linkages, etc. when the servo is installed onto the model, but in case the neutral position cannot be centered, this function can be used to set it from the transmitter.

- P** If the sub trim value becomes large, adjust the servo horn position or linkages so that the value becomes closer to 0. If the sub trim value is too large, dead zones could result and the servo may not operate at the extremities of its movement range.

TH TRIMRATE Throttle Trimrate

Adjusts the amount of movement associated with one click of the throttle trim button.

[Setting Range]

TH TRIM RATE : 1 ~ 10
(Default : 5)

- P** Although the amount of movement of one interval can be adjusted, the lower the number the smaller the amount of movement.
- P** The overall number of intervals does not change, so a change in trim rate will result in a change in the range in which the trim can be used to make corrections.
- P** If the trim rate is changed when the trim is already set, the trim may be thrown off. If the trim setting is 0 then this does not apply.)
- P** Lower trim rates enable fine adjustments, but the effects may not be apparent depending on the servo used. If there is a lot of slop in the linkage or servo saver, fine trim adjustments could cause the user to constantly worry about the trim settings. In that case, please reexamine the linkages, etc.

TH SPEED Throttle Speed

Settings related to throttle control.

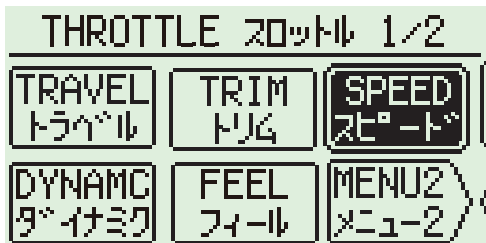

TH SPEED スピード	
TH TURN ターンスピード	100%
TH RETURN リターンスピード	100%

▶ TH TURN Throttle Turn Speed

Modify the speed of the throttle's movement (towards forward acceleration).

▶ TH RETURN Throttle Return Speed

Modify the speed of the throttle's return movement.

▶ TH TURN Throttle Turn Speed

This function delays the conversion of the throttle control signal to make the car easier to control.

[Setting Range]

TH TURN SPEED : 1 ~ 100%
(Default : 100%)

[Example]

If the car spins or otherwise does not drive straight when the throttle is applied suddenly, limiting the throttle speed can be effective.

P This product enables you to set throttle speed to either POSITION or SPEED. (Depending on the POSITION setting, SPEED's modifiable settings may change.)

P Effective speed values are dependent on the speed characteristics of your selected servo.

TH RETURN Throttle Return Speed

This function delays the conversion of the throttle control signal to make the car easier to control.

※ The [TURN] direction is adjusted with [Throttle Turn Speed].

[Setting Range]

TH RETURN SPEED : 1 ~ 100%
(Default : 100%)

[Example]

If the car spins or otherwise does not drive straight when the throttle is applied suddenly, limiting the throttle speed can be effective.

P This product enables you to set throttle speed to either POSITION or SPEED. (Depending on the POSITION setting, SPEED's modifiable settings may change.)

P Effective speed values are dependent on the speed characteristics of your selected servo.

DYNAMC Throttle Dynamics

Settings related to throttle control.

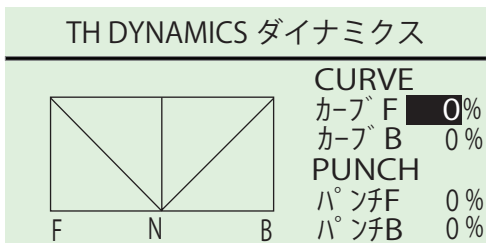
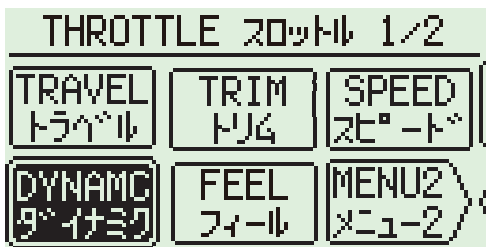

► CURVE F Throttle Curve Forward

Modify the movement speed ratio which corresponds to how much throttle is applied.

► CURVE B Throttle Curve Brake

Modify the movement speed ratio which corresponds to how much throttle brake is applied.

► PUNCH F Throttle punch Forward

Modify how much the throttle initially accelerates from neutral position.

► PUNCH B Throttle punch Brake

Modify how much the brake initially accelerates from neutral position.

► CURVE Steering Curve

This function sets the signal conversion rate to a curve to enable quicker or milder response. Likewise, braking can also be set to a braking curve.

[Setting Range]

TH CURVE F : -100 ~ 0 ~ 100%

(Default : 0%)

TH CURVE B : -100 ~ 0 ~ 100%

(Default : 0%)

- P** When [Throttle Punch] is activated, the characteristics of the throttle curve value is also added to the Throttle Punch value.
- P** Positive values (+1 to +100) equal high initial response followed by mild response. Negative values (-1 to -100) equal a mild initial response followed by high response.
- P** When using this in conjunction with other functions, adjust one at a time to confirm their effects to produce an effective overall setting.
- P** This function adjusts only the curve. Use the [Throttle Punch] function if you wish to adjust the initial response.

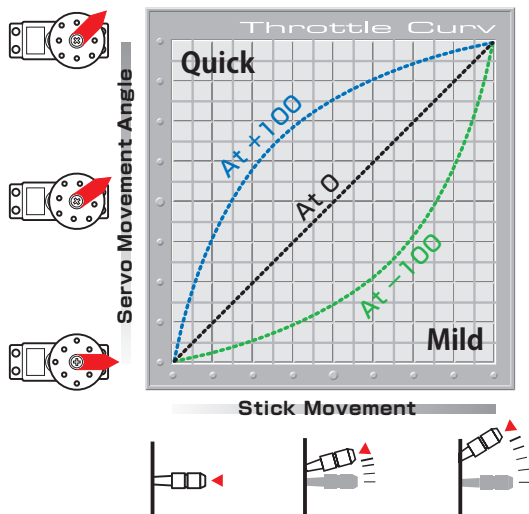

► PUNCH Throttle Punch

This function quickens the throttle's initial response and can be used to instill a sense of power when the throttle initially moves from neutral.

[Setting Range]

TH PUNCH F : 0 ~ 50%

(Default : 0%)

TH PUNCH B : 0 ~ 50%

(Default : 0%)

- P** The larger the value, the larger the amount of throttle movement. However, depending on other settings, the throttle operation may become jagged.
- P** If using this in conjunction with other functions such as [Throttle ABS], confirm the operation before using.

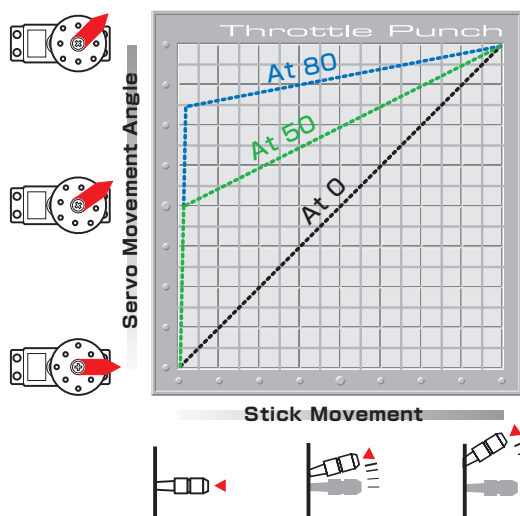

FEEL Throttle feel MENU

FEEL function provides changing the throttle feeling.

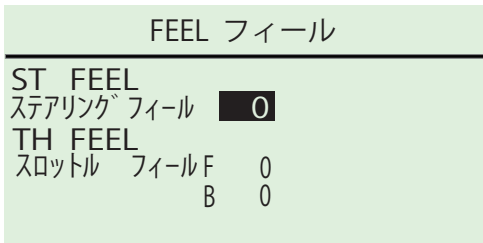
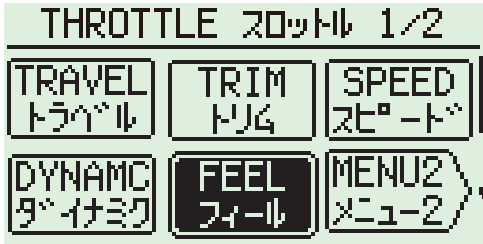

- ▶ **ST FEEL Steering Feeling**
Refer to "Steering Feel " (p.47)
- ▶ **TH FEEL F Throttle feel F**
Adjust forward throttle feeling.
- ▶ **TH FEEL B Throttle feel B**
Adjust brake feeling.

▶ TH FEEL Throttle feel

FEEL function provides changing the throttle feeling.

[Setting Range]

TH FEEL F : -50 ~ 0 ~ 50%

(Default : 0%)

TH FEEL B : -50 ~ 0 ~ 50%

(Default : 0%)

P Take into account such factors as the servo used, car, driving surface, etc. when adjusting throttle feel settings.

☐☐ OVERRIDE Throttle Override

Arrange another maximum brake setting and steering travel setting, which can be activated/deactivated by the ET lever or BT button.

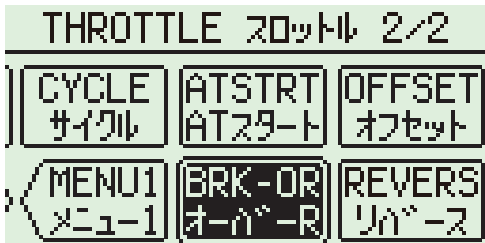

OVERRIDE オーバ-ライド	
KEY	
キー	OFF
BRAKE	
ブレーキ	100
STTRAVEL	
STトラベル	100

▶ KEY キー

Assigns a key to be used to activate/deactivate the override.

▶ BRAKE ブレーキ

Sets the brake override's brake setting.

▶ ST TRAVEL ステアリングトラベル

Adjust the steering angle according to the driving conditions to make the car easier to control.

[Setting Range]

KEY : OFF, ET1 ~ 5, BT1

(Default : OFF)

BRAKE : 0 ~ 150

(Default : 100)

ST TRAVEL : 0 ~ 150

(Default : 100)

[Example(throttle brake override)]

If a change in driving conditions is foreseen, the throttle brake setting can be changed during driving.

[Example(Steering travel override)]

Convenient for changing the steering angle on straights to give the car better straight-line stability.

P [OR] Display on the Function Monitor!

Operating the key that is assigned by [KEY] will result in [OR] being displayed on the initial screen's function monitor. If that key is pressed while at the initial screen, [OR] will disappear from the function monitor.

P When you only want to change the brake override set point, the numerical value of the steering travel override becomes effective at the same time.

Please input the same numerical value for the steering travel and the steering travel override when you do not want to change a value of the steering travel.

P When you only want to change the Steering travel override set point, the numerical value of the brake override becomes effective at the same time.

Please input the same numerical value throttle travel B and the brake override when you do not want to change a value of the brake travel.

☐☐ REVERSE Throttle Reverse

Modify the throttle direction.

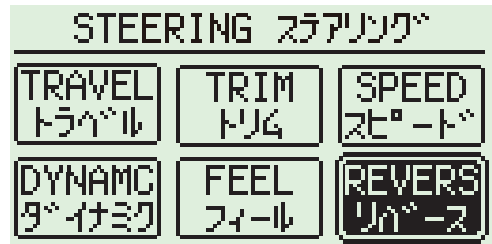

REVERSE リバース	
ST REVERSE	
ステアリング リバース	NORM
TH REVERSE	
スロットル リバース	NORM

▶ TH REVERSE Throttle reverse

[Setting Range]

ST REVERSE :

Refer to "Steering Reverse" (p.47)

TH REVERSE :

NORM (Normal)、REVS (Reverse)

(Default : NORM)

! Throttle direction varies from car to car and should be checked when the R/C equipment has been installed.

! For electric cars, the throttle is set by the ESC so there is no need to set this function. However, some older ESCs will not function properly unless reverse is also set.

☐☐ CYCLE Throttle Cycle

Add a change to the operation of throttle brakes.

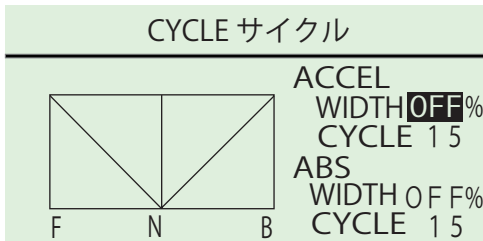
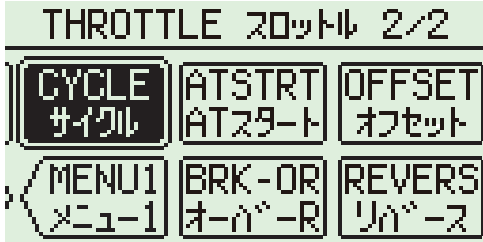

▶ ACCEL Throttle Acceleration

Modify the amount of acceleration burst of the throttle.

▶ ABS

Modify the amount of brake pumping.

▶ ACCEL Throttle Acceleration

Just like professional drivers who are capable of precise throttle inputs, this function enables fine throttle adjustments to allow quicker cornering.

[Setting Range]

WIDTH : OFF ~ 100%

(Default : OFF)

CYCLE : 1 ~ 30

(Default : 15)

[Example]

By setting the throttle to feather automatically, the car could be made to grip and corner faster on low-grip surfaces.

P [CYC] Display on the Function Monitor!

If [WIDTH] is not set to OFF, [CYC] will be displayed on the initial screen's function monitor. If the key assigned to CYCLE is pressed while at the initial screen, [CYC] will disappear from the function monitor.

P Setting [WIDTH] to 0 will deactivate Acceleration.

P If [CYCLE] is set at a large value, the servo's operation frequency will increase.

P Take into account such factors as the servo used, car, driving surface, etc. when adjusting all settings. Conduct test drives to find the best setting values.

▶ ABS

To prevent tires from locking up during sudden braking, brake pumping will be applied.

[Setting Range]

WIDTH : OFF ~ 100%

(Default : OFF)

CYCLE : 1 ~ 30

(Default : 15)

[Example]

This function is effective when your car's wheels lock up under braking and disturbs the car's balance. It will help enable smooth cornering performance.

P [CYC] Display on the Function Monitor!

If [WIDTH] is not set to OFF, [CYC] will be displayed on the initial screen's function monitor. If the key assigned to CYCLE is pressed while at the initial screen, [CYC] will disappear from the function monitor.

P Setting [WIDTH] to 0 will deactivate ABS.

P If [CYCLE] is set at a large value, the servo's operation frequency will increase.

P Take into account such factors as the servo used, car, driving surface, etc. when adjusting all settings. Conduct test drives to find the best setting values.

P For electric cars, it may be easier to understand if the throttle channel is connected temporarily to the servo to check ABS operation instead of to the ESC.

P When "ACCEL" and "ABS" either one or both become effective, "CYC" is displayed at the same position of the initial screen.

! Setting a large [CYCLE] or [WIDTH] value may increase the servo's power consumption and also shorten its lifespan.

ATSTRT Throttle Auto-Start

This function sets the throttle output to a fixed level at startup, regardless of how much the throttle trigger is pulled.

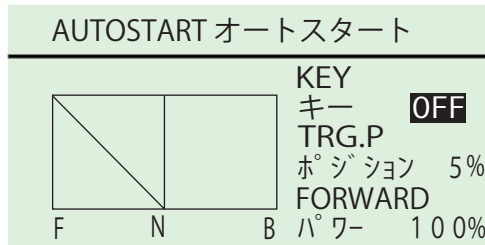
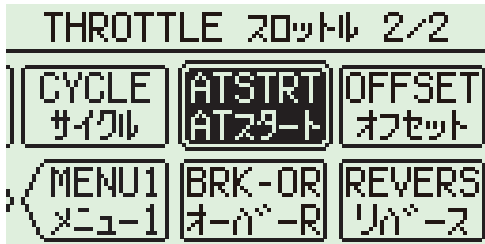

[Setting Range]

KEY : OFF, ET1 ~ 5, BT1

(Default : OFF)

TRG.P : 5 ~ 100%

(Default : 5%)

FORWARD : 0 ~ 100%

(Default : 100%)

[Example]

Launching from the starting line.

- ① Assign KEY (ET1-5/BT1).
- ② Operate an assigned key and validate [autostart].
- ③ Operate the throttle trigger and the launching starts when throttle trigger reaches [TRG.P].

P The function will not operate until the throttle trigger reaches the set position.

P When the throttle is released, the function is deactivated and the throttle returns to normal operation.

P **[AUT] Display on the Function Monitor!**
If the key assigned to Auto-Start is pressed, [AUT] will be displayed on the initial screen's function monitor. If this key is pressed while at the initial screen, [AUT] will disappear from the function monitor.

! Normally, full throttle is set for launching from the starting line. However, tire and surface conditions may mean full throttle will not be effective. Conduct tests and make adjustments

OFFSET Throttle OFFSET

Used to offset the throttle's neutral position.

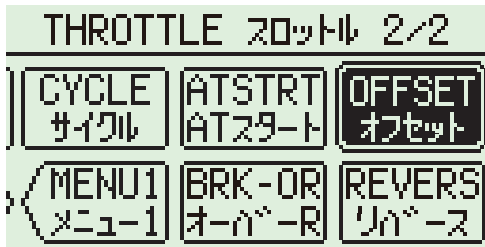

OFFSET オフセット			
OFFSET	KEY		
オフセット	キー	OFF	OFF
MODE	BUTTON		
モード	N.BRK	ボタン	TGLE
OFFSETKEY			
オフセットキー	OFF		

▶ OFFSET Throttle OFFSET

Sets the amount of neutral offset.

▶ MODE OFFSET MODE

Choice N.BRK (neutral brakes) or I.UP (idle up.)

▶ OFFSETKEY Throttle OFFSET KEY

Assigns a key to be used to change the amount of neutral offset.

▶ KEY

Assigns a key to be used to activate/deactivate the OFFSET Function.

▶ BUTTON

Sets the method of activation.

TGLE : If a key is assigned to Idle Up, press once to activate and press again to deactivate.

PUSH : It is only activated when the key is pushed and held. The operations is deactivated when Key is released.

[Setting Range]

OFFSET (Neutral brake) : -100 ~ OFF

(Default : OFF)

OFFSET (Idle up) : -100 ~ OFF ~ 100

(Default : OFF)

MODE : N.BRK, I.UP

(Default : N.BRK)

OFFSETKEY : OFF, ET1 ~ 5

(Default : OFF)

KEY : OFF, ET1 ~ 5, BT1

(Default : OFF)

BUTTON : TGLE, PUSH

(Default : TGLE)

[Example(Neutral brake)]

This function enables a light brake application at the moment when the throttle position changes from acceleration to deceleration.

[Example(Idle up)]

Raising the idling has the effect of improving a glow engine car's launch performance. It is also useful for canceling the neutral brake of a motor with strong cogging and preventing engine stalls when glow engine cars enter the pit for refueling.

P [OFS] Display on the Function Monitor!

If the key assigned to OFFSET is pressed, [OFS] will be displayed on the initial screen's function monitor. If this key is pressed while at the initial screen, [OFS] will disappear from the function monitor.

P Throttle can be operated even when Idle Up is activated. The throttle travel F/B point does not change during this time.

! Cannot use the function of "N.BRK" and "I.UP" both at the same time.

! When the EX-2 is turned off in the state of the OFFSET effect and transmitter is switched back on again, the function of OFFSET becomes invalid due to the safety precautions. Please activate effect again in KEY which you assigned it to.

! When setting value of the OFFSET to a very large value, there may become some mistakes by an ESC that has a reverse function and may operate in the reverse mode.

■ Glossary

This section explains terms which appear in this instruction manual as well as terms which are common in the radio control hobby.

2.4GHz	A radio frequency range which is higher than previous ones such as 27MHz and 40MHz. However, this also means it is also more direct and signal transmission may be difficult if there are interfering objects between the transmitter and receiver.
4WS	A feature which changes the steering angle of all four wheels according to the driving condition to enable greater stability.
7.2V Servo	A servo which uses a separate power source for its motor. In the case of electric R/C cars, KO Propo's unique system sees the servo draw power from the 7.2V battery used for running the car.
27MHz	One of the radio frequency ranges used for the R/C hobby. 12 bands exist for both ground-based and airborne R/C models.
40MHz	One of the radio frequency ranges used for the R/C hobby. 8 bands and 5 bands are assigned for use with ground-based and airborne R/C models respectively.
AC Charger	A battery charger which plugs into the standard 100V wall socket (in Japan). It often requires charging times of several hours or more.
Alarm	A buzzer sound emitted by the transmitter. It may be used as a warning notification, etc.
Amp	See ESC.
Analog Servo	A type of servo which uses analog-type integrated circuits (IC).
Backlight	Since LCDs do not generate their own light and are difficult to see in dark places, this light is placed beneath it to illuminate the display.
Band	Another word for radio frequency. This can be set with frequency crystals and different crystals can dictate the frequencies used in a certain frequency range.
Band ID Tag	An item which indicates to others the frequency that a particular user is using.
Brake Pumping	The repeated action of applying and releasing the brakes.
Carburetor	A device which mixes air and fuel in an engine and governs engine RPM.
Center Trim	A trim which only adjusts the position of neutral without disturbing the overall range of travel.
Channel	Refers to the number of servos, etc. which can be controlled by a transmitter or their individual signal numbers.
Clutch	A device which is used to engage/disengage an engine's drive shaft with the transmission.
Connector	An electric circuit contact unit which can be connected/disconnected.
CPU	The core of a computer which performs digital calculations for various uses. Also sometimes called an MPU.
Crystal	A device which sets the frequency used by a transmitter. 27MHz and 40MHz systems require crystals for changing frequencies while DSSS and FHSS 2.4GHz systems do not.
Cursor	A marker on the display which indicates the position in the text which can be controlled at that time.
Cycle	A process which returns to the beginning and repeats itself.
Databank	A module containing additional memory which may be used to increase the amount of model memory.
DC Charger	A battery charger which uses a 12V battery or other stable 12V power source.
DDS	Acronym for Direct Digital System. Previous transmitters transmitted an analog signal, but transmitters such as Eurus and EX-1, which use DDS, transmit a digital signal to enable lag-free, direct control.
Dead Zone	An area in which transmitter wheel or trigger movement does not result in servo operation. It could be caused by worn out components and may be resolved using VRADJ.
Delay	When an operation is slow, or has been slowed.

Digital Servo	A type of servo which uses digital-type integrated circuits (IC).
Discharger	A device which forcibly discharges remaining electricity from batteries such as Ni-Cd.
DSSS	Acronym for Direct Sequence Spread Spectrum. It is a type of spread spectrum transmission system which uses the 2.4GHz band.
Duty Cycle	A ratio between two operations.
EEPROM	A type of memory in which stored data is not deleted when the power is turned off. This product features this type of memory.
ESC	An acronym for Electronic Speed Controller, which controls the speed of the motor on an electric-powered R/C car.
ET	An acronym for Electric Trim. Button Trim is similarly shortened as BT.
Fail-Safe Adapter	A device which sets the servo horn to a predetermined position to prevent the car from going out of control when signal interference is experienced.
FET Servo	A high-end servo in which the motor features field-effect transistors as opposed to bipolar transistors.
FHSS	Acronym for Frequency-Hopping Spread Spectrum. Like DSSS, it is a type of spread spectrum transmission system.
Frequency Range	A range of radio wave frequencies such as 27MHz, 40MHz, 2.4GHz, etc.
High Frequency ESC	An ESC which utilizes a high frequency to control the motor. Nearly all current ESCs are high frequency types, but older ESCs which are not also exist. There are ESCs to match either brushed or brushless motors.
ICS (Interactive Communication System)	This system is unique to KO Propo and enables two-way communication with a PC. By using the Interface Kit (sold separately), the transmitter's internal memory data may be edited on a PC.
Internet	A global communications network which connects smaller networks made up of multiple PCs. This network enables the release of information via websites around the world, communication via E-mail, etc.
Jog Dial	A type of rotating dial which has no stops. Each click of the dial equates to a one point adjustment to the data to be modified and it is convenient for making large adjustments at one time.
LCD	Acronym for Liquid Crystal Display. The screen is used to display letters, numbers, etc.
LED	Acronym for Light Emitting Diode. It is a type of semi-conductor which uses electricity to generate light.
Linkage	A component which connects the servo to another part of the car chassis.
Lithium-Ferrite (Li-Fe) Battery	A type of battery which is quick to charge and is good for repeated recharges. They are also less susceptible to natural discharging and are easy to manage, making them safer compared to other types of lithium batteries.
Lithium-Polymer (Li-Po) Battery	A type of lithium battery which is lightweight and available in various sizes. They are equipped with balance connectors since there is a risk of fire/explosion if they are overcharged.
Megahertz (MHz)	A unit of frequency. 1000 Hertz (Hz) = 1 KiloHertz (kHz), 1000 kHz = 1 MHz.
Memory	A term which refers to a location where information is temporarily stored (on a PC for example). Transmitters feature non-volatile memory where the stored information is not erased when power is turned off (refer to EEPROM).
Mixing	A feature which combines the signals for multiple operations or effects into a more efficient output signal.
Monitor	A function which checks the operation of each channel.
Neutral	The position of the transmitter controls when they are not operated, or the position of the servo horn at that time.
Neutral Brake	A feature where braking is applied when the throttle is returned from forward acceleration to neutral position. Also called "drag brake."
Ni-Cd	A type of battery which can be recharged for repeated use. Other types of rechargeable batteries include Ni-MH and Li-ion.

Ni-MH	Compared to Ni-Cd batteries, Ni-MH batteries have a larger capacity. They are more environmentally-friendly since it does not contain Cadmium, but they are also more susceptible to damage from overdischarging.
Noise	Electrical interference. Since it is a type of frequency, it could cause the receiver to operate in error.
Override	When a high-priority (1CH / 2CH) function setting is switched to a low-priority one.
Pairing	The act of writing a 2.4GHz transmitter's ID into a receiver so that the receiver only chooses to receive that transmitter's signals. This must be done once before a transmitter is used.
PC Interface	An adapter used to connect a transmitter to a PC to enable the adjustment of the former's settings on the latter.
Preset	The act of specifying a setting position in advance.
Propo	Japanese language abbreviation of "proportional." Refers to an R/C transmitter or the transmitter/receiver combination.
Pushrod	A rod-shaped linkage.
Quick Recharger	A charger which could recharge Ni-Cd, Ni-MH, etc. batteries in a short amount of time.
R/C Equipment Tray	A tray/deck on an R/C car chassis on which the receiver servo, etc. are installed.
Receiver (RX)	A device which receives radio signals from the transmitter and passes them on to the servo and ESC. Use of the same type of signal as the transmitter is required.
Regulator	A circuit which stabilizes the input voltage to the level of the required voltage.
Reset	Returning the settings to the original preset condition.
Response	The time between a transmitter input and a receiver reaction.
RF Module	A component which generates and transmits radio frequencies. They exist in 27MHz, 40MHz, 2.4GHz (DSSS), and 2.4GHz (FHSS) types, with some transmitters allowing modules to be interchanged.
Rubber Grommet	A rubber component attached to the servo case ears which protects the servo from vibrations.
Servo	A device which translates the transmitter's radio signals into mechanical rotational movement.
Servo Saver Horn	A horn which features an internal shock absorber. This is included in the kit.
Spec List	A list which describes the makeup, performance, etc. of a piece of R/C equipment.
Spline	Another word for "universal." Due to the offset integrated into the output shaft's groove and the horn's hole, this will precisely match their positions when spun.
Sub Trim	Adjusts the overall steering angle range. ※Refer to Trim and Sub Trim Usage
Swing	A repeated action between two set points.
Torque	A measure of the force at work in the rotating shafts of motors, servos, etc.
Transmitter (TX)	A device which sends out radio waves to a receiver linked to servos, ESCs, etc. to control an R/C model.
Travel	The angle/amount of servo horn movement.
Trigger	A mechanism on a transmitter which looks like a gun trigger, the operation of which controls the throttle.
Trim	A mechanism which adjusts the neutral position of each channel.
VR	Acronym for Variable Resistor. An electrical component which senses the position of the steering, throttle, etc.
Website	Places on the internet on which information is disseminated. They are accessed via PC software called web browsers. Some websites are also known as homepages.
Wheel	A mechanism on a transmitter which is rotated left and right to control steering.
Width	The range within which the ABS or throttle operates.

■ Repair Policy

All KOPROPO systems will have a serial number for each region that it is sold in.

This will be used to know where the system was purchased. So if you need any service the Tx will have to be sent back to the region from where it was originally purchased. All repair service must be sent to the region where it was originally purchased. KO Japan will only accept international repairs from the regional distributor.

www.kopropro.co.jp

■ FCC statement

This device complies with part 15 of the FCC Rules.

Operation is subject to the following two conditions: (1)

This device may not cause harmful interference, and (2)

this device must accept any interference received,

including interference that may cause undesired operation.

Modifications not expressly approved by this company could void the user's authority to operate the equipment.

interference by one or more of the following measures:

- Reorient or relocate the receiving antenna.
- Increase the separation between the equipment and receiver.
- Connect the equipment into an outlet on a circuit different from that to which the receiver is connected.
- Consult the dealer or an experienced radio/TV technician for help.
- list of external antennas (antenna type, max gain, necessary cable length, connector type, ...)
- statement of professional installation
- notification that the amplifier can be used only in a system which it has obtained authorization

This equipment complies with FCC radiation exposure limits set forth for an uncontrolled environment. The antenna(s) used for this transmitter must not be collocated or operating in conjunction with any other antenna or transmitter within a host device,

except in accordance with FCC multi-transmitter product procedures.

■ Specifications

■ Transmitter: KT-415FH

Control Type: Steering wheel + Throttle trigger

Number of Channels: 4

Power Source: R03/AAA/UM4 battery x4

Current: Below 150mAh

Dimensions: 240.5 × 163 × 107.2mm
(including protrusions)

Weight: 510g (not including batteries)

※ No.80561 Standard Edition

Modulation Type: FHSS

Transmission Frequency Range:

HSS mode ; 2404-2476MHz

MHS mode ; 2404-2460MHz

■ Receiver: KR-241FH

※ No.80561 Standard Edition

Receiver Modulation Type: FHSS

Number of Channels: 4

Receiver Frequency Range: 2.4GHz

Operating Voltage: 4.8V - 7.4V

Neutral Balance: 1.5 mSec

Dimensions: 29.3 × 24.4 × 16.0mm

Weight: 7.8g

※Note: Receiver will be changed by Product Model.

KO PROPO
EX-II