

**TABLE OF CONTENTS LIST**

**APPLICANT:** KONDO KAGAKU CO., LTD.

**FCC ID:** QH9T125003

**TEST REPORT:**

PAGE 1.....GENERAL INFORMATION & TECHNICAL DESCRIPTION  
PAGE 2.....TECHNICAL DESCRIPTION CONTINUED. & RF POWER OUTPUT  
PAGE 3.....MODULATION CHARACTERISTICS  
                  OCCUPIED BANDWIDTH  
PAGE 4.....OCCUPIED BANDWIDTH PLOT  
PAGE 5.....FIELD STRENGTH OF SPURIOUS EMISSION  
PAGE 6.....METHOD OF MEASURING RADIATED SPURIOUS EMISSIONS  
PAGE 7.....FREQUENCY STABILITY  
PAGE 8-11.....TEST EQUIPMENT LIST

**EXHIBIT CONTAINING:**

EXHIBIT 1.....BLOCK DIAGRAM  
EXHIBIT 2.....SCHEMATICS  
EXHIBIT 3.....USERS MANUAL  
EXHIBIT 4.....LABEL SAMPLE  
EXHIBIT 5.....LABEL LOCATION  
EXHIBIT 6.....EXTERNAL PHOTOGRAPHS  
EXHIBIT 7.....INTERNAL PHOTOGRAPHS  
EXHIBIT 8.....PARTS LIST  
EXHIBIT 9.....ALIGNMENT PROCEDURE  
EXHIBIT 10.....CIRCUIT DESCRIPTION  
EXHIBIT 11.....TEST SET UP PHOTOGRAPH

APPLICANT: KONDO KAGAKU CO., LTD.

FCC ID: QH9T125003

REPORT #: K\KONDO GH9\950JT3\950JT3TestReport.doc

TABLE OF CONTENTS

GENERAL INFORMATION

2.1033(c)(1)(2) KONDO KAGAKU CO., LTD. will sell the FCCID:  
QH9T125003 Radio Control transmitter in  
quantity, for use PART 95 SUBPART C.

KONDO KAGAKU CO., LTD.  
17-7 HIGASHI-NIPPORI 4 CHOME,  
ARAKAWA-KU  
TOKYO 116-0014

2.1033(c)(3) Instruction manual is included as exhibit #5.

2.1033 (4) Type of Emission: 8K0F1D  
95.631(b)(1)

Bn = 2M + 2DK  
M = 4,800 Bits per second  
D = 800 Hz (Peak Deviation)  
K = 1  
Bn = 2(4800/2) + 2(1600)(1) = 4.8K + 3.2K = 8.0k  
ALLOWED AUTHORIZED BANDWIDTH = 8.00 kHz.

95.631(b) Authorized Bandwidth 8 kHz for RC Transmitter

2.1033(c)(5) Frequency Range: 75.410-75.990 MHz  
95.623(a)

- (6) Power Range and Controls: There are NO user Power controls.
- (6) Function of each electron tube or semiconductor device or other active circuit device:  
See Exhibit #10.
- (7) Maximum Output Power Rating: 0.513 W ERP.
- (8) DC Voltages and Current into Final Amplifier:

FINAL AMPLIFIER ONLY

Vce = 12.0Volts DC  
Ice = 0.069A.  
Pin = 0.8Watts

2.1033(c)(9) Tune-up procedure. The tune-up procedure is included as  
Exhibit #9.

- 2.1033(c)(10) Complete Circuit Diagrams: The circuit diagram is included as part of Exhibit # 2.
- (10) Description of all circuitry and devices provided for determining and stabilizing frequency is given in EXHIBIT #10.
- 2.1033(c)(11) The Equipment identification is shown as Exhibit #4.
- 2.1033(c)(12) Photographs of the equipment are shown as Exhibits No. 6-7.
- 2.1033(c)(13) Equipment employing Digital modulation. N/A.
- 2.1033(c)(14) The data required by 2.1046-2.1057 follows;
- 2.1046 RF power is measured by the ERP METHOD. There is no provisions to limit the power. With a nominal battery voltage of 12.0 VDC, and the transmitter properly adjusted the RF output measures:
- $P_o = 0.513$  Watts ERP
- 2.1046 RF power output.

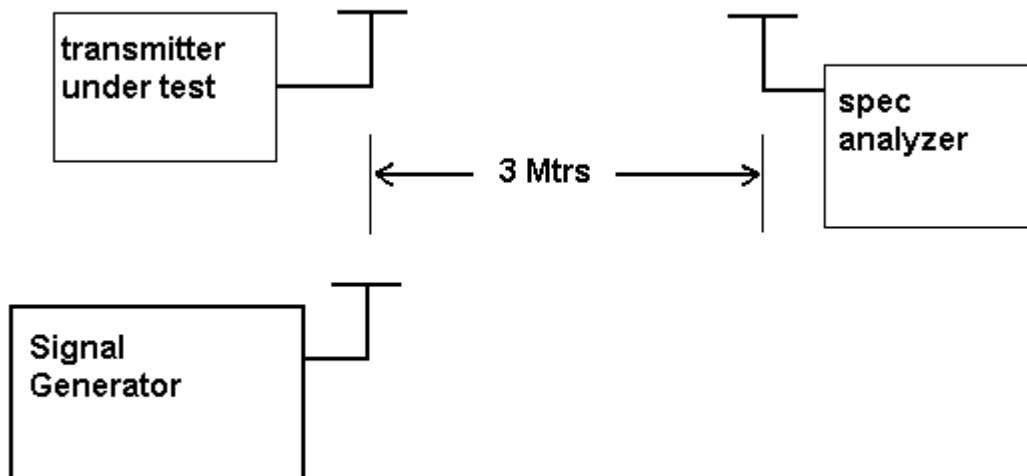

2.1047

Modulation characteristics:

AUDIO FREQUENCY RESPONSE

The Voice is NOT allowed in this band.

2.1049

95.635(b)

Occupied bandwidth:

- (1) At least 25dB on any frequency removed from the center of the authorized bandwidth by more than 50% up to and including 100% of the authorized bandwidth.
- (10) At least 45 dB on any frequency removed from the center of the authorized bandwidth by more than 100% up to and including 125% of the authorized bandwidth.
- (11) At least 55 dB on any frequency removed from the center of the authorized bandwidth by more than 125% up to and including 250% of the authorized bandwidth.
- (12) At least  $56 + 10 \log_{10}(T)$  dB on any frequency removed from the center of the authorized bandwidth by more than 250%.

Radiotelephone transmitter with modulation limiter.  
Test procedure diagram

OCCUPIED BANDWIDTH MEASUREMENT

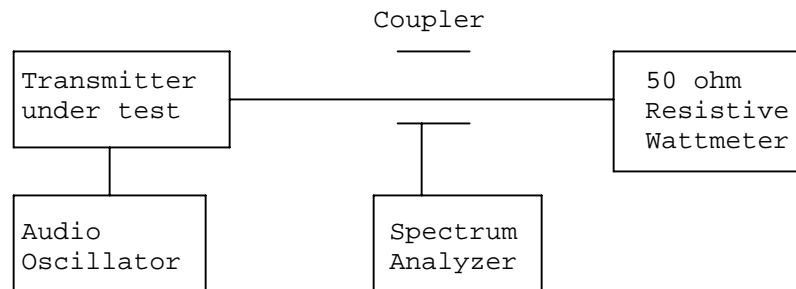

OCCUPIED BANDWIDTH PLOT

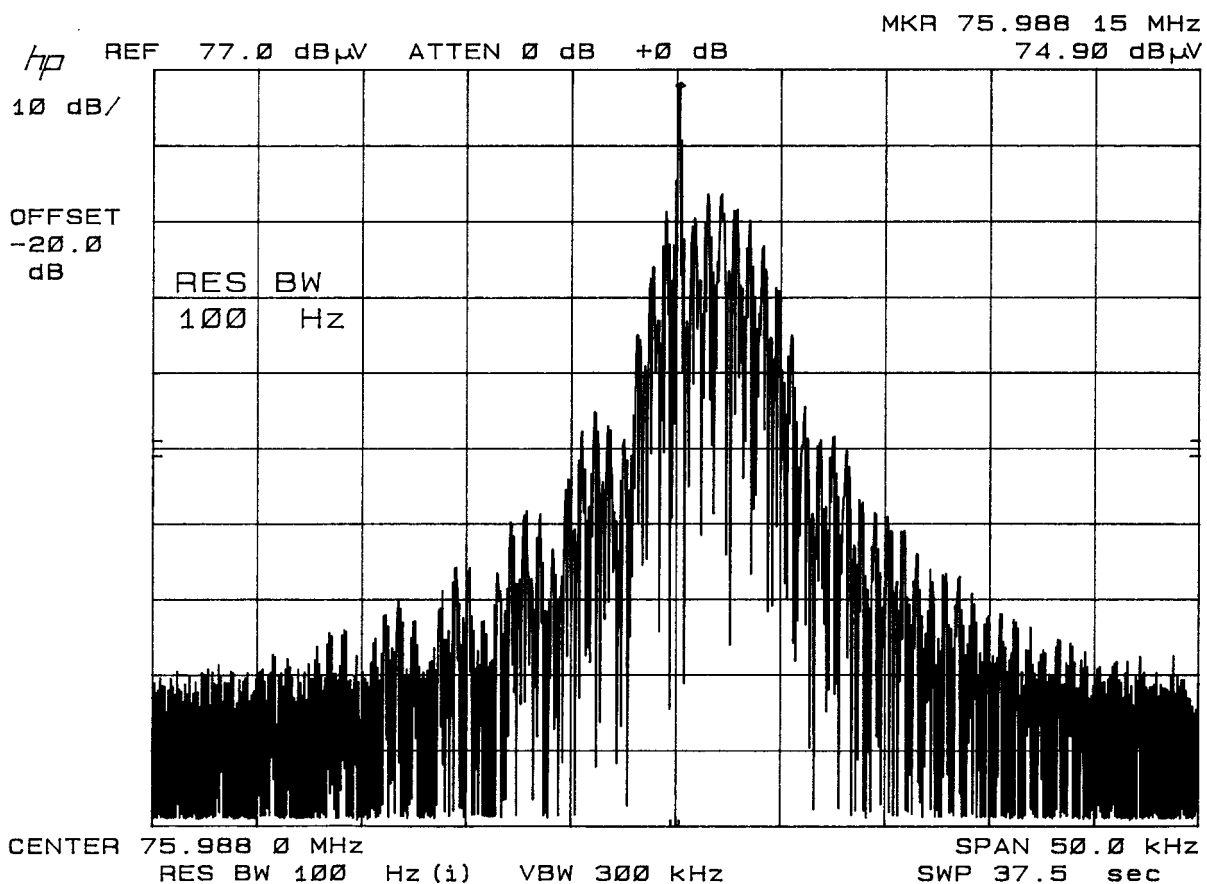

APPLICANT: KONDO KAGAKU CO., LTD.

FCC ID: QH9T125003

REPORT #: K\KONDO GH9\950JT3\950JT3TestReport.doc

2.1051 SPURIOUS EMISSIONS AT ANTENNA TERMINALS.  
 NOT APPLICABLE, NO antenna port. This UUT has a permanently attached antenna.

2.1053 UNWANTED RADIATION:  
 95.635(1)(3)(7)(10)(11)(12)

REQUIREMENTS:

At least 56 + 10log(T) on any frequency removed from the center of the authorized bandwidth by more than 250%.

$$56 + 10\log(0.513) = 53.1 \text{ dB}$$

TEST DATA:

Emission Frequency (MHz)	Polarity Antenna	Corrected EUT Signal Reading (dBm)	Coax Loss	Sub. Ant.	dB Below Carrier (dBc)
75.69	V	27.1	0	0	0.00
151.33	V	-27.0	0	0	54.10
226.98	V	-37.2	0	0	64.30
302.72	V	-51.1	0	0	78.20
378.38	V	-51.0	0	0	78.10
454.08	V	-48.9	0	0	76.00
529.79	V	-50.8	0	0	77.90
605.46	H	-43.5	0	0	70.60
681.14	H	-38.7	0	0	65.80
756.78	V	-41.7	0	0	68.80

METHOD OF MEASUREMENT: The procedure used was C63.4-1992. The unit was operating into its permanently attached antenna at a height of 80 cm. The spectrum was scanned from 30 to at least the tenth harmonic of the fundamental using a HP model 8566B spectrum analyzer and an appropriate antenna. Measurements were made at the open field test site of TIMCO ENGINEERING INC. located at 849 N.W. State Road 45 Newberry, FL 32669.

APPLICANT: KONDO KAGAKU CO., LTD.

FCC ID: QH9T125003

REPORT #: K\KONDO GH9\950JT3\950JT3TestReport.doc

Method of Measuring Radiated Spurious Emissions

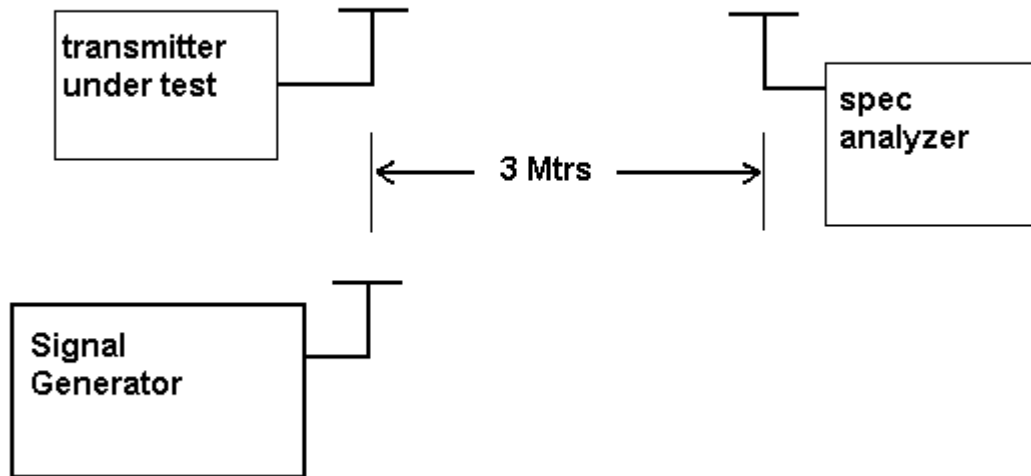

Equipment placed 80cm above ground on a rotatable platform.

2.1055(a)(1) Frequency stability:  
95.623(b)

Temperature and voltage tests were performed to verify that the frequency remains within the .002%, 20 ppm specification limit. The test was conducted as follows:  
The transmitter was placed in the temperature chamber at 25 degrees C and allowed to stabilize for one hour. The transmitter was keyed ON for one minute during which four frequency readings were recorded at 15 second intervals. The worse case number was taken for temperature plotting. The assigned channel frequency was considered to be the reference frequency. The temperature was then reduced to -30 degrees C after which the transmitter was again allowed to stabilize for one Hour. The transmitter was keyed ON for one minute, and again frequency readings were noted at 15 second intervals. The worst case Number was recorded for temperature plotting. This procedure was repeated in 10-degree increments up to + 50 degrees C.

Readings were also taken at the end point of the battery voltage of 12.0VDC.

MEASUREMENT DATA:

Assigned Frequency (Ref. Frequency): 75.688 756

TEMPERATURE C	FREQUENCY MHz	PPM
REFERENCE_____	75.688 756	00.00
-30C_____	75.688 923	2.59
-20C_____	75.689 075	4.60
-10C_____	75.689 113	5.10
0C_____	75.689 068	4.51
10C_____	75.688 916	2.50
20C_____	75.688 727	0.00
30C_____	75.688 635	-1.22
40C_____	75.688 623	-1.37
50C_____	75.688 648	-1.04

	DATA	VOLTS	PPM
-15% BATTERY END POINT	75.688 692	10.2	-0.46

RESULTS OF MEASUREMENTS: The maximum frequency variation over the temperature range was -1.37 to +5.10ppm. The maximum frequency variation with voltage was -0.46 ppm.

APPLICANT: KONDO KAGAKU CO., LTD.

FCC ID: QH9T125003

REPORT #: K\KONDO GH9\950JT3\950JT3TestReport.doc

Page 7 of 11



# EMC Equipment List

Last Update: 7/8/03

	DEVICE	MFGR	MODEL	SERNO	CAL/CHAR DATE	DUE DATE or STATUS
X	3-Meter OATS	TEI	N/A	N/A	Listed 1/13/03	1/13/06
	3/10-Meter OATS	TEI	N/A	N/A	Listed 3/26/01	3/26/04
X	Receiver, Beige Tower Spectrum Analyzer	HP	8566B Opt 462	3138A07786 3144A20661	CAL 8/31/01	8/31/03
X	RF Preselector	HP	85685A	3221A01400	CAL 8/31/01	8/31/03
X	Quasi-Peak Adapter	HP	85650A	3303A01690	CAL 8/31/01	8/31/03
X	Preamplifier	HP	8449B-H02	3008A00372	CHAR 3/4/01	3/4/03
	Receiver, Blue Tower Spectrum Analyzer	HP	8568B	2928A04729 2848A18049	CAL 4/15/03	4/15/05
	RF Preselector	HP	85685A	2926A00983	CAL 4/15/03	4/15/05
	Quasi-Peak Adapter	HP	85650A	2811A01279	CAL 4/15/03	4/15/05
	Receiver, Silver/Grey Tower Spectrum Analyzer	HP	8566B Opt 462	3552A22064 3638A08608	CAL 10/14/02	10/14/04
	RF Preselector	HP	85685A	2620A00294	CAL 10/14/02	10/14/04
	Quasi-Peak Adapter	HP	85650A	3303A01844	CAL 10/14/02	10/14/04
	Preamplifier	HP	8449B	3008A01075	CHAR 1/28/02	1/28/04
X	Biconnical Antenna	Electro-Metrics	BIA-25	1171	CAL 4/26/01	4/26/03
	Biconnical Antenna	Eaton	94455-1	1096	CAL 10/1/01	10/1/03
	Biconnical Antenna	Eaton	94455-1	1057	CAL 3/18/03	3/18/05
	BiconiLog Antenna	EMCO	3143	9409-1043		
X	Log-Periodic Antenna	Electro-Metrics	LPA-25	1122	CAL 10/2/01	10/2/03
	Log-Periodic Antenna	Electro-Metrics	EM-6950	632	CHAR 10/15/01	10/15/03
	Log-Periodic Antenna	Electro-Metrics	LPA-30	409	CAL 3/4/03	3/4/05
	Log-Periodic Antenna	Eaton	96005	1243	CAL 5/8/03	5/8/05

APPLICANT: KONDO KAGAKU CO., LTD.

FCC ID: QH9T125003

REPORT #: K\KONDO GH9\950JT3\950JT3TestReport.doc

	DEVICE	MFGR	MODEL	SERNO	CAL/CHAR DATE	DUE DATE or STATUS
	Dipole Antenna Kit	Electro-Metrics	TDA-30/1-4	152	CAL 3/21/01	3/21/04
	Dipole Antenna Kit	Electro-Metrics	TDA-30/1-4	153	CAL 9/26/02	9/26/05
	Double-Ridged Horn Antenna	Electro-Metrics	RGA-180	2319	CAL 2/17/03	2/17/05
	Horn Antenna *(at 3 meters)	Electro-Metrics	EM-6961	6246	CAL 3/31/03	3/31/05
	Horn Antenna *(at 10 meters)	Electro-Metrics	EM-6961	6246	CAL 6/4/03	6/4/05
	Horn Antenna	ATM	19-443-6R	None	No Cal Required	
	Passive Loop Antenna	EMC Test Systems	EMCO 6512	9706-1211	CHAR 7/10/01	7/10/03
	Harmonic Mixer with Horn Antenna	Oleson Microwave Labs	M08HW/A	F30425-1	CHAR 4/25/03	4/25/05
	Harmonic Mixer with Horn Antenna	Oleson Microwave Labs	M12HW/A	E30425-1	CHAR 4/25/03	4/25/05
	Line Impedance Stabilization . . .	Electro-Metrics	ANS-25/2	2604	CAL 10/9/01	10/9/03
	Line Impedance Stabilization . . .	Electro-Metrics	EM-7820	2682	CAL 3/12/03	3/12/05
	Termaline Wattmeter	Bird Electronic Corporation	611	16405	CAL 5/25/99	5/25/01
	Termaline Wattmeter	Bird Electronic Corporation	6104	1926	CHAR 9/7/01	9/7/03
	Oscilloscope	Tektronix	2230	300572	CAL 7/3/03	7/3/05
	System One	Audio Precision	System One	SYS1-45868	CHAR 4/25/02	4/25/04
X	Temperature Chamber	Tenney Engineering	TTRC	11717-7	CHAR 1/22/02	1/22/04
	AC Voltmeter	HP	400FL	2213A14499	CAL 10/9/01	10/9/03
	AC Voltmeter	HP	400FL	2213A14261	CHAR 10/15/01	10/15/03
	AC Voltmeter	HP	400FL	2213A14728	CHAR 10/15/01	10/15/03
	Digital Multimeter	Fluke	77	35053830	CHAR 1/8/02	1/8/04
	Digital Multimeter	Fluke	77	43850817	CHAR 1/8/02	1/8/04
	Digital Multimeter	HP	E2377A	2927J05849	CHAR 1/8/02	1/8/04
	Multimeter	Fluke	FLUKE-77-3	79510405	CHAR 9/26/01	9/26/03
	Peak Power Meter	HP	8900C	2131A00545	CAL 7/2/03	7/2/05

APPLICANT: KONDO KAGAKU CO., LTD.

FCC ID: QH9T125003

REPORT #: K\KONDO GH9\950JT3\950JT3TestReport.doc

	<b>DEVICE</b>	<b>MFGR</b>	<b>MODEL</b>	<b>SERNO</b>	<b>CAL/CHAR DATE</b>	<b>DUE DATE or STATUS</b>
	Power Sensor	Agilent Technologies	84811A	2551A02705	CAL 7/2/03	7/2/05
	Power Meter	HP	432A	1141A07655	CAL 4/15/03	4/15/05
	Power Sensor	HP	478A	72129	CAL 4/15/03	4/15/05
	Power Meter And Sensor	Bird	4421-107 4022	0166 0218	CAL 4/16/03	4/16/05
	Digital Thermometer	Fluke	2166A	42032	CAL 1/16/02	1/16/04
	Thermometer	Traulsen	SK-128		CHAR 1/22/02	1/22/04
	Thermometer	Extech	4028	14871-2	CAL 3/7/03	3/7/05
	Hygro-Thermometer	Extech	445703	0602	CAL 10/4/02	10/4/04
	Frequency Counter	HP	5352B	2632A00165	CAL 11/28/01	11/28/03
	Frequency Counter	HP	5385A	2730A03025	CAL 3/7/03	3/7/05
	Service Monitor	IFR	FM/AM 500A	5182	CAL 11/22/00	11/22/02
	Comm. Serv. Monitor	IFR	FM/AM 1200S	6593	CAL 5/12/02	5/12/04
	Signal Generator	HP	8640B	2308A21464	CAL 2/15/02	2/15/04
	Sweep Generator	Wiltron	6648	101009	CAL 4/15/03	4/15/05
	Sweep Generator	Wiltron	6669M	007005	CAL 3/3/03	3/3/05
	Modulation Analyzer	HP	8901A	3435A06868	CAL 9/5/01	9/5/03
	Modulation Meter	Boonton	8220	10901AB	CAL 4/15/03	4/15/05
	Near Field Probe	HP	HP11940A	2650A02748	CHAR 2/1/01	2/1/03
	BandReject Filter	Lorch Microwave	5BR4-2400/ 60-N	Z1	CHAR 4/17/03	4/17/05
	BandReject Filter	Lorch Microwave	6BR6-2442/ 300-N	Z1	CHAR 4/17/03	4/17/05
	BandReject Filter	Lorch Microwave	5BR4-10525/ 900-S	Z1	CHAR 4/12/03	4/12/05
	Notch Filter	Lorch Microwave	5BRX-850/ X100-N	AD-1	CHAR 4/17/03	4/17/05
	High Pass Filter	Unk	3768(5)-400	041	CHAR 12/17/02	12/17/04
	High Pass Filter	Microlab	HA-10N		CHAR 11/17/02	11/17/04

APPLICANT: KONDO KAGAKU CO., LTD.

FCC ID: QH9T125003

REPORT #: K\KONDO GH9\950JT3\950JT3TestReport.doc

Page 10 of 11

	<b>DEVICE</b>	<b>MFGR</b>	<b>MODEL</b>	<b>SERNO</b>	<b>CAL/CHAR DATE</b>	<b>DUE DATE or STATUS</b>
	High Pass Filter	Microlab	HA-20N		CHAR 12/17/02	12/17/04
	Audio Oscillator	HP	653A	832-00260	CHAR 12/1/02	12/1/04
	Audio Generator	B&K Precision	3010	8739686	CHAR 12/1/02	12/1/04
	Frequency Counter	HP	5382A	1620A03535	CHAR 3/2/01	3/2/03
	Frequency Counter	HP	5385A	3242A07460	CAL 3/7/03	3/7/05
	Amplifier	HP	11975A	2738A01969	CHAR 3/1/01	3/1/03
	Egg Timer	Unk			CHAR 2/1/02	2/1/04
	Measuring Tape, 20M	Kraftixx	0631-20		CHAR 2/1/02	2/1/04
	Measuring Tape, 7.5M	Kraftixx	7.5M PROFI		2/1/02	2/1/04
	Coaxial Cable #51	Insulated Wire Inc.	NPS 2251-2880	Timco #51	CHAR 1/23/02	1/23/04
	Coaxial Cable #64	Semflex Inc.	60637	Timco #64	CHAR 1/24/02	1/24/04
	Coaxial Cable #65	General Cable Co.	E9917 RG233/U	Timco #65	CHAR 1/23/02	1/23/04
	Coaxial Cable #106	Unknown	Unknown	Timco #106	CHAR 1/23/02	1/23/04

APPLICANT: KONDO KAGAKU CO., LTD.

FCC ID: QH9T125003

REPORT #: K\KONDO GH9\950JT3\950JT3TestReport.doc

Page 11 of 11