

Thank you for purchasing this product. Before using the product, please also check this instruction manual and the instruction manual of your transmitter. Due to product improvements, the contents of this manual are subject to change without notice. Please note.

Important: Changes or modifications to this unit not expressly approved by the party responsible for compliance could void the user's authority to operate the equipment.

For your safety Please note the handling and use of this product.

Warning The contents of this display shows a possibility of death or where a serious injury may occur.

•This product is manufactured for surface use radio controls. *Discontinue use for all other purposes. Discontinue use in the event of a thunder storm. *There is danger of a lightning striking the antenna of the transmitter. •Discontinue use when consuming alcohol or medication that may hinder concentration or judgment. *Unexpected accidents are caused with a judgment mistake. •When rain and puddles are present, please discontinue use. *There are times when water enters into the equipment and control will be lost. •Only use the batteries specified in the instruction manual of the transmitter. •To turn the system on, start by turning on the transmitter then the receiver. To turn off the system, turn off the receiver first, then the transmitter in this sequence. •Please be sure to use only our products for the transmitter and servos. *Concerning the damage and the like, which is generated when combining products that are not our company's genuine products we do not owe responsibility. •Altering the transmission module is inhibited by law and is subjected to penal code violations. Resolution remodeling of all products may result in the cause of a short and other accidents. In addition, if this product is altered we will refuse repair service. •Please do not use this product inside an airplane, hospital, near any automatic control equipment, medical electrical machinery and apparatus such as fire alarms. In addition with respect to the law, if this product affects other radio equipment and electronic equipment, use must be discontinued at once.

Our company cannot owe responsibility from the nature of the radio control models. And the customer assumes all responsibilities that result from this product being used.

Installing the Receiver Unit

*Be careful not to pinch the antenna when installing the receiver cover.

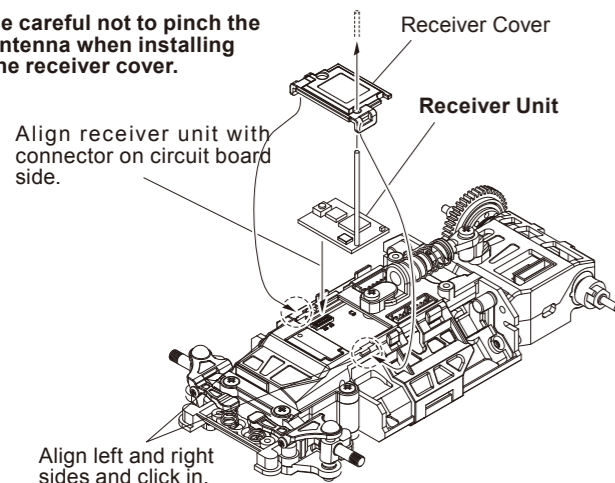

Warning This product is for use only with the Kyosho MINI-Z EVO series.

Pairing 1 *Please use EX-NEXT with Ver. 3.00.00 or later.

1 Pairing operation of the transmitter

①-1. Set the RF mode.

FUNCTION
> TLMY
> RF MODE

Select [MINIZ].

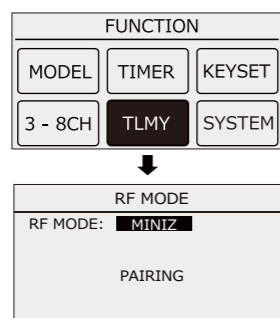

***It cannot be used in radio wave modes other than [MINIZ].**

If [MINIZ] does not appear in RF mode, please upgrade the software to version 2.00.00 or higher to use it.

*Please refer to the KO homepage for upgrade instructions.

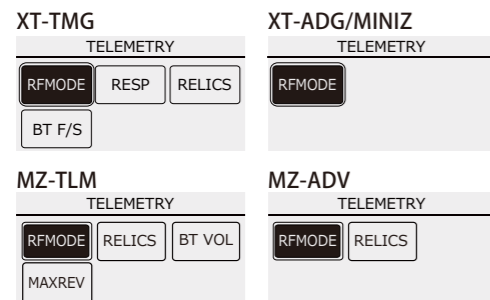

*The items displayed on the TELEMETRY screen differ depending on the RF mode selected.

FCC statement This device complies with part 15 of the FCC Rules. Operation is subject to the following two conditions: (1) This device may not cause harmful interference, and (2) this device must accept any interference received, including interference that may cause undesired operation. Changes or modifications not expressly approved by the party responsible for compliance could void the user's authority to operate the equipment.

Attention This display shows the possibility of a substantially damaging accident can cause injury.

•Please avoid storage in a place of high temperatures and high humidity because it may cause the breakdown, damage and deformation of the product. •Please note when using with an engine model, place where exhaust and the waste oil will not come into contact with the product. *In case of submerging in oil or water, please send it out for repair. •This product's performance is designed for use in the shown specified usage which is based on this instruction manual and the instruction manual of the transmitter which is used. When the instructions are not understood, please contact our service department for advise. •After verifying the safety of use, think of all the accidents possible and please enjoy with responsibility.

KONDO KAGAKU Co., Ltd. 4-17-7 Higashi-Nippori, Arakawa-ku, Tokyo Japan
Phone : +81-03-3807-7648
<https://www.koproco.jp>

①-2.

Pairing start.

While in the RF MODE screen, move the cursor to PAIRING,

Press and hold the ENT key.

When the screen changes, go to pairing mode.

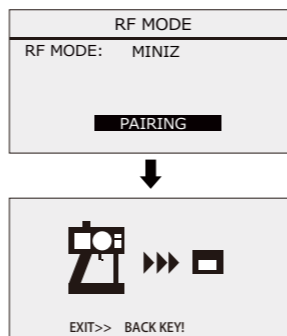

2 Preparing the receiver

Prepare the pairing stick and locate the LED indicator and pairing button.

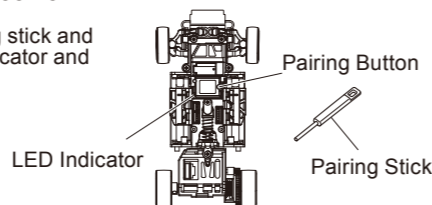

3 Pairing operation of the Chassis

③-1. Chassis (Switch ON)

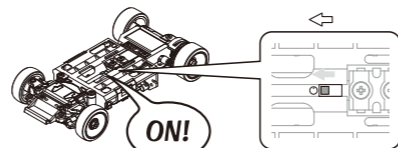

③-2. Using the pairing stick, press and release the pairing button for 1 second.

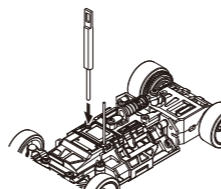

③-3. Ensure that the LED indicator lights up.button.

③-4. Return the EX-NEXT pairing screen to the menu screen.

LED Indicator will show the following.
Light is ON : Pairing has been successful.
Light is flashing : Pairing has not be completed. Switch the transmitter and chassis power off and do pairing again.

This Module is limited, requiring the host integrator to file a Class II permissive change for each specific host per the test plan defined in the module integration instructions. Any minimum separation distance requirement must be stated in the integration instructions. This category is generally used for low-power and low-duty cycle devices (example: No distance requirement). When this module adding into a host, The Field strength of fundamental and spurious emissions need to be re-test for Class II filling. Host labeling requirement: "Contains FCC ID: QH9R15MOD" on the host no-detachable visible place. The host product manufacturer is responsible for compliance to any other FCC rules that apply to the host not covered by the modular transmitter grant of certification. FCC CLASII Permissive Change is needed for each new host configuration by the Grantee of KONDO KAGAKY CO.,LTD.This limit wireless module antenna cannot be changed and that any change will require FCC Class II Permissive Change.This limit wireless module installed in a new host needed to comply with FCC Part 15.249

4 Preparations for Operation

For MINI-Z EVO Receiver unit EX-NEXT MC-8 82043 (Green Antenna)

④-1. Press the BACK button on the EX-NEXT from the screen below and the MINI-Z can be operated once the screen switches to the normal screen.

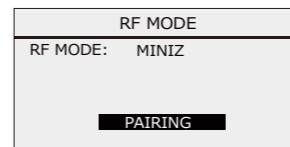

For MINI-Z EVO2 Receiver unit for KO PROPO 82045 (Blue Antenna)

④-1. The EVO2 communication mode is displayed, select the mode you want to use from TLMY and ADV.

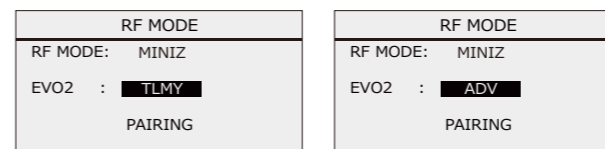

④-2. Make the changes and press the ENT key to switch the RF MODE of the MINIZ, wait a few seconds.

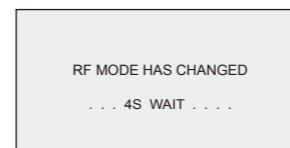

④-3. Press the BACK button on the EX-NEXT and the MINI-Z can be operated once the screen switches to the normal screen.

Pairing 2 *Pairing again with RF-MODE already switched to MINI-Z.

- Set the EX-NEXT to pairing mode.
- When the vehicle is turned on, the LED indicator will be in a flashing state.
- Press the pairing button to turn on the LED indicator, and then release the button to turn off the LED.
- Press the BACK button on the EX-NEXT and turn on the power as usual to operate the MINI-Z.

<Pairing method 1 and 2 comon>

The LEDs light up alternately corresponding to the RF MODE.

MINIZ : Light Blue / Blue
MZ-TLM : Light Blue / Blue
MZ-ADV : Light Blue / Green

*In rare cases, pairing data may be lost, but this is not a malfunction. Please set up the pairing again.

If the LED flashes, the receiver is not getting the EX-NEXT signal and the pairing procedure should be repeated.

About gyro adjustment *When using the MZW405 gyro unit

FUNCTION
> 3-8CH
> GYRO

ET3=STEERING
ET5=THROTTLE

Gyro adjustment is possible.

3-8CH		
3CH MODE	OFF	GYRO
GYRO	2WAY	TWIN
SET	3WAY	4WS
	5WAY	AMP
4CH MODE	ANALOG	T-MIX
GYRO		
SET		>>NEXT

MINI-Z EVO/EVO2 Transmitter/receiver compatibility chart

	Transmitter			Chassis	
	EXP-201	EXP-104S/M	MC-8	MR-04 EVO2	MR-03 EVO MA-030 EVO
82045 MINI-Z EVO 2 Receiver Unit for KO PROPO	EX-NEXT /LDT	EX-RR 2/LDT	MC-8	MR-04 EVO2	MR-03 EVO MA-030 EVO
Basic control function	Ver.2.00 Later	⊘	✓ ※Slow	✓	✓
Telemetry function	Ver.3.00 Later	⊘	⊘	✓	⊘
Advanced mode	Ver.3.00 Later	⊘	⊘	✓	⊘
82043 MINI-Z EVO Receiver Unit EX-NEXT MC-8	Ver.2.00 Later	⊘	✓ ※Slow	✓	✓
82040 MINI-Z EVO Receiver Unit	⊘	Ver.1.00 Later	⊘	✓	✓

✓ Available ⊘ Not available