

A B C D E F G H I J K L M N O P Q R S T

	PART NO	DESCRIPTION	QTY
01	108A021	CASE LOWER	1
02	108A022	CASE UPPER	1
03	108A023	ANTENNA COVER UPPER	2
04	108A024	ANTENNA COVER LOWER	2
05	108A025	ANTENNA COVER BODY	2
06	108A026	COVER	1
07	108A027	RAIL	2
08	108A028	LIGHTPIPE	1
09	108A029	PCB ASSEMBLY	1
10	108A012	WALL BRACKET ASSEMBLY	1
11	SEE BOM	TAPTITE SCREW M5 X 30	4
12	SEE BOM	TAPTITE SCREW M4 X 10	5
13	SEE BOM	TAPTITE SCREW M3 X 6	4
14	SEE BOM	TAPTITE SCREW M3 X 12	7
15	108A035	REMOVAL TOOL	1
16	108_008	PORT LABEL	1
17	108A009	PRODUCT LABEL	1
18	SEE BOM	WARRANTY SEAL	1
19	SEE BOM	EMC FOAM	A/R

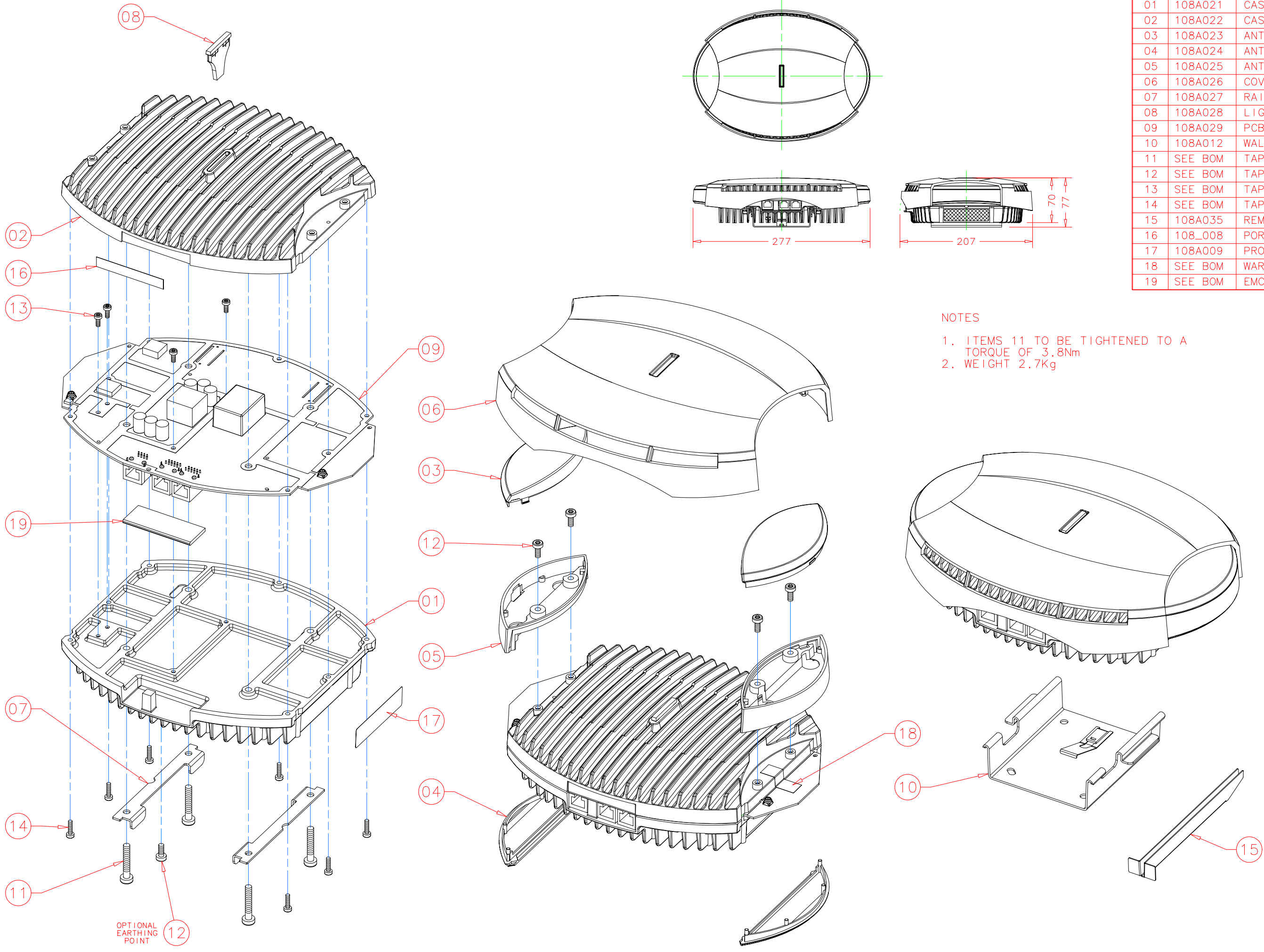

NOTES
 1. ITEMS 11 TO BE TIGHTENED TO A TORQUE OF 3.8Nm
 2. WEIGHT 2.7Kg

ip.access
 www.ipaccess.com
 Capital Park
 Fulbourn
 Cambs CB1 5XE
 Tel: +44 1223 219000
 Fax: +44 1223 219099

CONFIDENTIAL

© This drawing is the property of ip.access ltd and must not be copied or disclosed without prior written consent

Scale: 1:2
 Drawn by: CP
 Date started: 21-06-01
 Checked: N/A
 Material: N/A
 Finish: N/A

All dimensions in mm
 Tolerances Unless Otherwise Stated:
 2 DEC PLACES ±0.10 mm
 1 DEC PLACE ±0.2 mm
 0 DEC PLACE ±0.5 mm Angular ±0.5°

ISSUE	DATE	CHANGE	INTL
XA	21/06/01	PRELIMINARY ISSUE	CP
XB	07/08/01	UPDATED	CP
A	23/08/01	PRODUCTION ISSUE ECN 0032	CP
B	21/12/01	ECN 0016	CP
C	13/02/02	ECN 0017	CP
D	03/04/02	ECN 0029	CP
E	30/04/02	ECN 0033 & ECN 0040	CP
F	20/02/03	ECN 0097	CP

Project: nanoBTS
 Title: nanoBTS ASSEMBLY
 Drawing Number: 108A017
 Sheet No: 1 of 1 Size: A2

A B C D E F G H I J K L M N O P Q R S T