



Installation Guide

***ip.access Ltd
Building 2020
Cambourne Business Park
Cambridge
CB3 6DW
United Kingdom***

ip.access

Customer Safety and Regulatory Information

Author(s)
Lance Davidson
26/10/2004

The information contained in this document is commercially confidential and must not be disclosed to third parties without prior consent.

1 REVISION HISTORY

Version	Change Summary	ECN	Date	Author
A	First release	0190	Sept 2004	LED
B	BSC notes updated	0243	Aug 2005	LED
C	Product 165 Included, Cambourne address updated	TBA	Dec 2005	LED

Contents

1	REVISION HISTORY	3
2	INTRODUCTION	5
2.1	Purpose and Scope	5
2.2	Related Documents	5
2.3	Terminology	5
2.4	Change Control	5
2.5	Document Organisation	5
3	Model 109 POWER SUPPLY	6
3.1	109 - Handbook - Warnings and Cautions	6
3.2	109 - Handbook - FCC Text	7
3.3	109 – Handbook - Industry Canada text	7
3.4	109 – Handbook - Regulatory Compliance Statement	7
4	Model 126 Ethernet Switch and Power Inserter	9
4.1	126 - Handbook - Warnings and Cautions	9
4.2	126 – Handbook - FCC Text	10
4.3	126 – Handbook - Industry Canada text	11
4.4	126 – Handbook - Regulatory Compliance Statement	11
5	NANOBTs Products	13
5.1	NanoBTS - Handbook - Warnings and Cautions	13
5.2	NanoBTS - Handbook - Parts required for each nanoBTS	14
5.3	NanoBTS - Handbook - Provision of Power to the nanoBTS	14
5.3.1	NanoBTS - Handbook - Installing the PSU at the Ethernet switch. .	16
5.3.2	Nano - BTS Handbook - Installing the PSU at the nanoBTS	16
5.4	NanoBTS - Handbook – FCC Text	17
5.5	NanoBTS - Handbook – IC Text	17
5.6	NanoBTS – Handbook - Regulatory Compliance Statement	18
6	Model 129 BSC (Base Station Controller)	19
6.1	BSC – Handbook – Warnings and Cautions	19
6.2	BSC – Handbook - FCC Text	21
6.3	BSC - Handbook - Industry Canada text	22
6.4	BSC - Handbook - Regulatory Compliance Statement	22

2 INTRODUCTION

2.1 Purpose and Scope

This document provides the customer with safety and regulatory warnings, cautions and information for the IP Access range of products.

Products covered are the model 108, 110, 139, 140, 165 and 178 range of nanoBTS's, model 109 and 126 power supplies, model 129 4U circuit switched BSC.

2.2 Related Documents

This document shall be referenced by the individual product's user guides.

2.3 Terminology

UL Underwriters Laboratories
FCC Federal Communications Commission
ICE Industry Canada
CE European Union

2.4 Change Control

Changes to this document shall be agreed and implemented according to the ECN procedures described within QS019, Approvals Liaison Engineer signature is required in all cases.

2.5 Document Organisation

This document is divided into sections by product type.

3 Model 109 POWER SUPPLY

3.1 109 - Handbook - Warnings and Cautions



This document is written in English, please request a copy in your local language if required.



This product is only intended to power products approved by IP Access. Ensure that only IP Access products are connected to an Ethernet circuit enabled for 48V operation, this also applies to outlets remote from the unit



For indoor use only, output cabling is SELV / LAN for indoor routing only.



Do not cover casing or otherwise impede cooling.



Do not apply power to unit if there is any evidence of condensation.



Do not open casing as mains voltages may be present within the unit.



90 to 264VAC input is via a 2 pin IEC C7 (figure 8) connector. Inlet cable assembly must carry a suitable local approval (e.g. UL marked for US and Canadian markets).

PSU109 – Environmental Specification

- -10 to +45 degrees Centigrade ambient operating temperature.
- This product has been Listed by UL for use in a 25 degree C ambient.
- -20 to +80 degrees C ambient storage temperature.
- 5 to 95% RH non condensing humidity.

3.2 109 - Handbook - FCC Text

WARNING

This is a class B product. In a domestic environment this product may cause radio interference in which case the user may be required to take adequate measures.

Federal Communications Commission

Note: This equipment has been tested and found to comply with the limits for a class B digital device, pursuant to part 15 of the FCC rules. These limits are designed to provide reasonable protection against harmful interference when the equipment is operated in a commercial environment. This equipment generates, uses, and can radiate radio frequency energy and, if not installed and used in accordance with the instruction manual, may cause harmful interference to radio communications. Operation of this equipment in a residential area is likely to cause harmful interference in which case the user will be required to correct the interference at his own expense.

3.3 109 – Handbook - Industry Canada text

This Class B digital apparatus complies with Canadian ICES-003.

Cet appareil numérisé de la classe B est conforme à la norme NMB-003 du Canada.

3.4 109 – Handbook - Regulatory Compliance Statement

EMC Standards

- EN 55022 and EN55024 (CE marked)
- FCC Part 15 class B
- ICES-003

Safety Standards

- EN60950 (CE marked)
- UL60950 Listed (File number E231617) (USA and Canada)

This product is intended for use in all
Member States of the European Union

“Hereby, ip.access declares that this Ethernet Power Inserter is in compliance with the essential requirements and other relevant provisions of Directives 73/23/EEC and 89/336/EEC.”

The PSU109 is supplied by Poly-Products Industries, model number ILA1711112.

A copy of regulatory compliance documentation may be obtained in writing from

“IP access Ltd, Building 2020, Cambourne Business Park, Cambourne, Cambridge, CB3 6DW, UK”.

4 Model 126 Ethernet Switch and Power Inserter

4.1 126 - Handbook - Warnings and Cautions



This document is written in English, please request a copy in your local language if required.



This product is only intended to power products approved by IP Access.



Ensure that only IP Access approved products are connected to an Ethernet circuit enabled for 48V operation, this also applies to outlets remote from the unit.



To be located in a restricted access location only (accessible to maintenance personnel only).



For indoor use only, output cabling is SELV / LAN for indoor routing only.



Do not block ventilation holes or otherwise impede cooling.



Refer to National Engineering Code (USA). Wiring methods must be in accordance with NEC Article 300.



When rack mounting, secure via front panel plate with 4 bolts and ensure that no additional load is placed upon the caseworks (e.g. heavy objects on top).



When rack mounting, ensure that the internal rack temperature does not exceed the rating of this product.



Do not apply power to unit if there is any evidence of condensation.



Do not open casing as mains voltages may be present within the unit.



AC inlet cable must carry suitable local approval (e.g. UL marking for US and Canadian markets).

126 - Input Power Source Specification

- Unit may be powered via AC or DC (not both).
- 90 to 132 and 180 to 264VAC (auto-ranging) via an IEC C13 connector. 135W, 2A rating.
- 47 to 57V DC via screw terminals on the front panel. 115W 3A rating. The installer must ensure that this supply connection is fused externally at 5A and provision is made for an external disconnection device.
- Appliance must be earthed, either via the mains connector (mains operation) or screw terminal on the front panel (DC operation).

126 – Environmental Specification

- -5 to +45 degrees C ambient operating
- -20 to +80 degrees C ambient storage
- 5 to 95% RH non condensing

4.2 126 – Handbook - FCC Text

WARNING

This is a class A product. In a domestic environment this product may cause radio interference in which case the user may be required to take adequate measures.

Federal Communications Commission

Note: This equipment has been tested and found to comply with the limits for a class A digital device, pursuant to part 15 of the FCC rules. These limits are designed to provide reasonable protection against harmful interference when the equipment is operated in a commercial environment. This equipment generates, uses, and can radiate radio frequency energy and, if not installed and used in accordance with the instruction manual, may cause harmful interference to radio communications. Operation of this equipment in a residential area is likely to cause harmful interference in which case the user will be required to correct the interference at his own expense.

4.3 126 – Handbook - Industry Canada text

This Class A digital apparatus complies with Canadian ICES-003.

Cet appareil numérisé de la classe A est conforme à la norme NMB-003 du Canada.

4.4 126 – Handbook - Regulatory Compliance Statement

The nanoBTS conforms to the following regulatory standards.

EMC Standards

- EN 55022 and EN55024 (CE marked)
- FCC Part 15 class A
- ICES-003

Safety Standards

- EN60950 (CE marked)

- IEC 60950
- UL60950 Listed (File number E230296) (USA and Canada)
- CB certificate (DK-7033)

This product is intended for use in all
Member States of the European Union

“Hereby, ip.access declares that this Ethernet Switch / Power Inserter is in compliance with the essential requirements and other relevant provisions of Directives 73/23/EEC and 89/336/EEC.”

A copy of regulatory compliance documentation may be obtained in writing from

“IP access Ltd, Building 2020, Cambourne Business Park, Cambourne,
Cambridge, CB3 6DW, UK”.

5 NANOBTs Products

5.1 NanoBTs - Handbook - Warnings and Cautions



This system is designed to be operated indoors as a fixed system device and must be located either on or near the ceiling away from the user. It must be mounted in a manner to ensure that all users and bystanders are kept a minimum of 20cm away from the integral antennas at all times.



Do not touch or move the antenna(s) while the unit is transmitting or receiving.



Do not hold any component containing a radio such that the antenna is very close to or touching any exposed parts of the body, especially the face or eyes while transmitting.



In most parts of the world, regulatory approval(s) are needed before the nanoBTs is operated.



Do not connect any device other than the nanoBTs to any RJ45 socket that has been enabled for nanoBTs connection (i.e. 48Vdc operation).



The nanoBTs is intended for dry indoor applications only. If evidence of condensation is present do not apply power to the nanoBTs.



The nanoBTs must only be powered using an ip.access model 109 PSU (PPI part number ILA1711112) or ip.access model 126 Ethernet switch and power inserter (unless prior written approval is obtained from IP Access). Model 165 BTs's may also be powered by a direct 48V connection using a PSU specified in writing by IP Access Ltd



PSU's supplied by ip.access must not be used for powering any other equipment (unless carried out in a manner having prior written approval from IP Access).



TIB ports on the NanoBTS may only be connected with ip.access supplied cables with part numbers 139-040, 139-041, 139-042, 139-043 or 165-076.



Fitting external antenna or antenna cabling to the BTS invalidates the type approval, CE marking and UL listing referred to herein (unless carried out in a manner having prior written approval from IP Access).



Maximum cable length from the Ethernet Hub, Switch or PSU is limited to 100m.

5.2 NanoBTS - Handbook - Parts required for each nanoBTS

- WALL FIXINGS: These are not normally provided as part of the NanoBTS but should be suitable for the wall material and weight of the NanoBTS (2.7kg). Suggested materials are 4 x 30mm no.10 woodscrews or M5 bolts and wall plugs (if required).
- PSU.
- NanoBTS complete with mounting bracket.
- RJ45-RJ45 connecting leads

5.3 NanoBTS - Handbook - Provision of Power to the nanoBTS

Power for the NanoBTS may be inserted at either the RJ45 outlet or at the output of the last Ethernet switch/hub/router etc. see figure below.

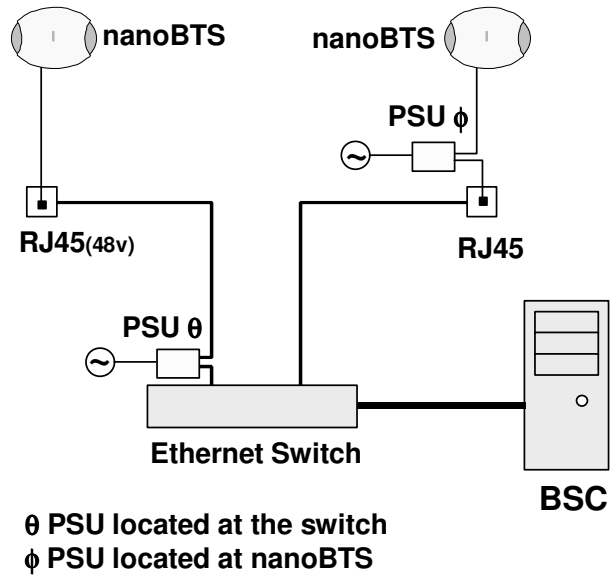

When using the ip.access model 126A Ethernet Switch and Power Inserter, external PSU's are not required, the NanoBTS is connected locally or via site cabling to the powered ports of the 126.

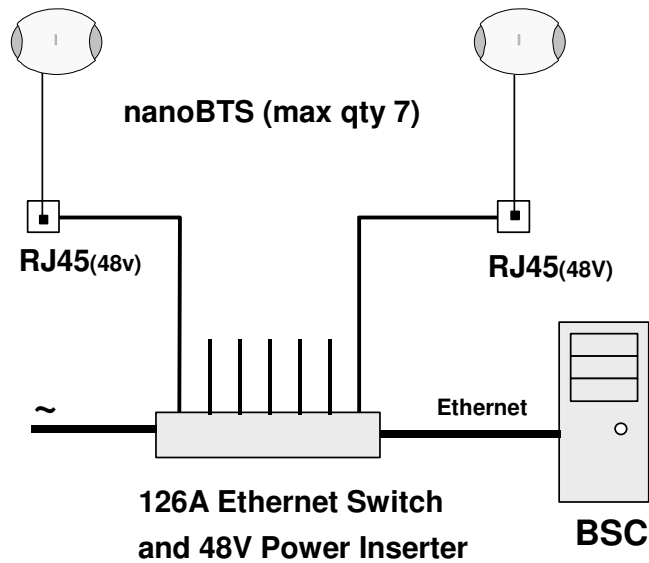

5.3.1 NanoBTS - Handbook - Installing the PSU at the Ethernet switch.

If the 109 PSU is located at the patch panel /output port of the Ethernet switch, it is important that the 109 PSU is connected exactly as illustrated below (failure to do so may cause damage to the switch). Ensure that the 109 PSU is placed in a location that is ventilated and that the connection leads provide no safety hazard.

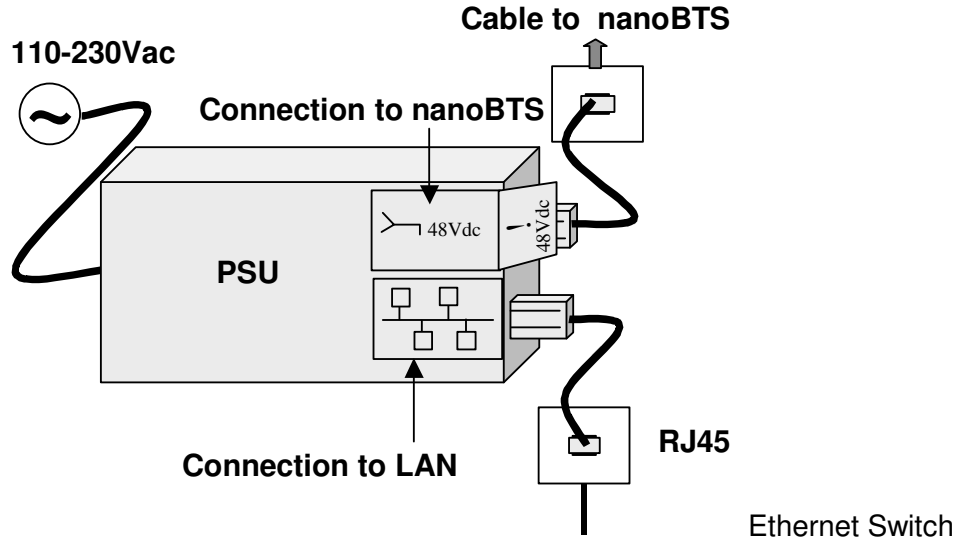

5.3.2 Nano - BTS Handbook - Installing the PSU at the nanoBTS.

Ensure that the 109 PSU is placed in a location that is ventilated and that the connection leads provide no safety hazard.

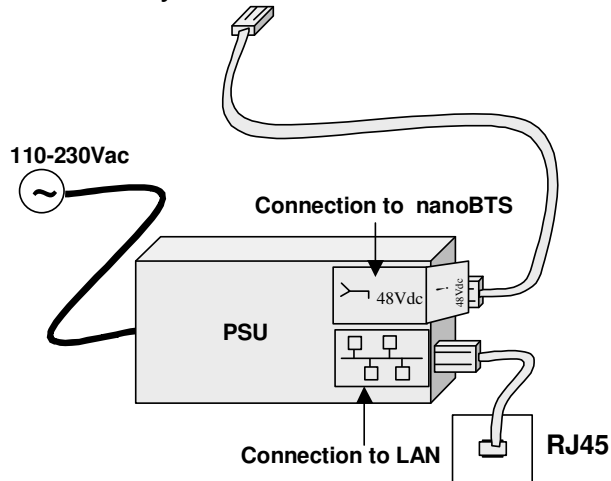

5.4 NanoBTS - Handbook – FCC Text

Standards

- FCC Rule 47 Parts 2, 15, 24

NOTE: Changes or modifications not expressly approved by the party responsible for compliance may void the user's authority to operate this equipment.

Model 110 NanoBTS has FCC ID QGGM180TVX
Model 140 NanoBTS has FCC ID QGGKU02ZZT
Model 165B NanoBTS has FCC ID QGGKU02ZZP

Federal Communications Commission

Note: This equipment has been tested and found to comply with the limits for a class A digital device, pursuant to part 15 of the FCC rules. These limits are designed to provide reasonable protection against harmful interference when the equipment is operated in a commercial environment. This equipment generates, uses, and can radiate radio frequency energy and, if not installed and used in accordance with the instruction manual, may cause harmful interference to radio communications. Operation of this equipment in a residential area is likely to cause harmful interference in which case the user will be required to correct the interference at his own expense.

5.5 NanoBTS - Handbook – IC Text

Standards

- RSS133 issue 2

NOTE: Changes or modifications not expressly approved by the party responsible for compliance may void the user's authority to operate this equipment.

Model 110 NanoBTS has IC (Industry Canada) ID 4644B-M180TVX
Model 140 NanoBTS has IC (Industry Canada) ID 4644A-KU02ZZT
Model 165B NanoBTS has IC (Industry Canada) ID TBA

5.6 NanoBTS – Handbook - Regulatory Compliance Statement

The nanoBTS conforms to the following regulatory standards.

Type Approvals

- GSM essential requirements under article 3.2 of the R&TTE directive ETSI EN 301 502. CE Marking (CE0168).
- FCC - see above.
- ICE – see above.

EMC Standards

- ETSI EN 301 489-1 and –8, ETSI EN 301 502.
- FCC - see above.
- ICE – see above.

Environmental Standards

- ETS 300 019.

Safety Standards

- EN60950 (CE Marking)
- IEC 60950
- UL60950 Listed (file number E230296, USA and Canada)
- CB Certificate

This product is intended for use in all
Member States of the European Union

“Hereby, ip.access declares that this NanoBTS is in compliance with the essential requirements and other relevant provisions of Directive 1999/5/EC.”

A copy of regulatory compliance documentation may be obtained in writing from

“IP access Ltd, Building 2020, Cambourne Business Park, Cambourne, Cambridge, CB3 6DW, UK”.

6 Model 129 BSC (Base Station Controller)

6.1 BSC – Handbook – Warnings and Cautions



This document is written in English, please request a copy in your local language if required.



To be located in a restricted access location (accessible to maintenance personnel only).



For indoor use only, Ethernet and E1/T1 cabling is LAN / SELV for indoor routing and termination only.



Do not block ventilation holes or otherwise impede cooling.



Refer to National Engineering Code (USA). Wiring methods must be in accordance with NEC Article 300.



When rack mounting, ensure that no additional load is placed upon the caseworks (e.g. heavy objects on top).



Unit Weight is 13Kg (29lbs). When rack mounting use 4 off M6 bolts (or equivalent) to secure the BSC chassis to the rack rails.



When rack mounting, ensure that the internal rack temperature does not exceed the rating of this product.



Do not apply power to unit if there is any evidence of condensation.



Do not open casing as mains voltages may be present within the unit.



Casing is to be operated with all covers (including slot covers) in place for safe operation and to ensure correct cooling airflow.



AC inlet cables must carry suitable local approval (e.g. UL marking for US and Canadian markets).



Connection points are provided at the front and rear of the BSC for personal electrostatic discharge wrist straps, these should be used when servicing the BSC to prevent damage to cards.



The processor card utilises a clock backup battery. CAUTION, Risk of explosion if battery is replaced by an incorrect type. Dispose of used batteries according to the suppliers instructions.



To avoid electric shock, do not connect safety extra low voltage (SELV) circuits to telephone network voltage (TNV) circuits. LAN ports contain SELV circuits, and WAN ports contain TNV circuits. Some LAN and WAN ports use RJ45 connectors, Use caution when connecting cables.

BSC - Input Power Source Specification

- There are two variants of the 4U chassis, AC powered or DC powered.
- 90 to 264VAC via three IEC-C13 connectors. 300W, 4A rating (per input).

- The AC variant has three independent inlets for the purposes of power source migration and redundancy, at least two of these require power for operation, all three require power for normal redundant operation.
- -38 to -75V (-48V nominal) DC via two sets of screw terminals. 500W 10A rating. The installer must ensure that each DC supply connection is fused externally at 5A and provision is made for an external disconnection device. Plastic covers (supplied) are to be fitted over -48V BSC connections.
- The DC variant has two inlets for the purposes of power source migration, these are internally diode combined, the external -48V supplies must therefore share a common reference.
- Appliance must be earthed, either via the mains connectors (AC mains operation) or screw terminal on the rear panel (DC operation). Earth cable to be minimum 0.75mm² section.

BSC – Environmental Specification

- 0 to +45 degrees C ambient operating
- -20 to +80 degrees C ambient storage
- 10 to 90% RH non condensing
- -100m to +3050m altitude

6.2 BSC – Handbook - FCC Text

WARNING

This is a class A product. In a domestic environment this product may cause radio interference in which case the user may be required to take adequate measures.

Federal Communications Commission

Note: This equipment has been tested and found to comply with the limits for a class A digital device, pursuant to part 15 of the FCC rules. These limits are designed to provide reasonable protection against harmful interference when the equipment is operated in a commercial environment. This equipment generates, uses, and can radiate radio frequency energy and, if not installed and used in accordance with the instruction manual, may cause harmful interference to radio communications. Operation of this equipment in a residential area is likely to cause harmful interference in which case the user will be required to correct the interference at his own expense.

6.3 BSC - Handbook - Industry Canada text

This Class A digital apparatus complies with Canadian ICES-003.

Cet appareil numérisé de la classe A est conforme à la norme NMB-003 du Canada.

6.4 BSC - Handbook - Regulatory Compliance Statement

The model 129 4U Circuit BSC carries CE and cTUVus markings, it conforms to the following regulatory standards.

EMC Standards

- ETSI EN 301 489-1 and ETSI EN 301 489-8 (CE Marking)
- ETSI EN 300 386 (CE Marking)
- FCC Part 15 class A (USA)
- ICES-003 (Canada)

Safety Standards

- EN60950 (CE Marking)
- IEC60950 (international)

- cTUVus – the BSC 4U chassis (including backplane, power supplies and cooling fan tray) is a TUV Rheinland Listed product for USA and Canadian markets.

This product is intended for use in all
Member States of the European Union

“Hereby, ip.access declares that model 129 4U CircuitBSC is in compliance with the essential requirements and other relevant provisions of Directives 1999/5/EC, 73/23/EEC and 89/336/EEC .”

A copy of regulatory compliance documentation may be obtained in writing from

“IP access Ltd, Building 2020, Cambourne Business Park, Cambourne, Cambridge, CB3 6DW, UK”.

END OF DOCUMENT