

**ELECTROMAGNETIC EMISSIONS COMPLIANCE REPORT  
INTENTIONAL RADIATOR CERTIFICATION TO  
FCC PART 15 SUBPART C (DTS) REQUIREMENT**

*OF*

**802.11b WLAN USB Stick**

**Model Name: WN220 / PN15 / CT-110 / WU022**

**Trade Name: AirVast Technology Inc. / Shuttle Inc. /  
Comtrend Corporation / PILOTECH SYSTEMS CO., LTD.**

**FCC ID: QDWWN220**

**REPORT NO: B30625214-RP**

*Prepared for*

**AirVast Technology Inc.  
4F-1, No. 1, Ln. 21, Hsin Hua Rd.,  
Kueishan Industrial Park, Taoyuan 330, Taiwan, R.O.C.**

*Prepared by*



**C&C LABORATORY, CO., LTD.  
No. 81-1, Lane 210, Bade Rd. 2,  
Luchu Hsiang, Taoyuan Hsien, Taiwan.**

TEL: 886-3-3240332

FAX: 886-3-3245235

**This report shall not be reproduced, except in full, without the written approval of  
C&C Laboratory, Co., Ltd.**



## VERIFICATION OF COMPLIANCE

**Applicant:** AirVast Technology Inc.  
4F-1, No. 1, Ln. 21, Hsin Hua Rd.,  
Kueishan Industrial Park, Taoyuan 330, Taiwan, R.O.C.

**Product Description:** 802.11b WLAN USB Stick

**Trade Name:** AirVast Technology Inc. / Shuttle Inc. / Comtrend Corporation /  
PILOTECH SYSTEMS CO., LTD.

**Model No.:** WN220 / PN15 / CT-110 / WU022

**Model Difference:** All the above models are identical except the model designation

**Serial Number:** N/A

**File Number:** B30625214-RP

**Date of test:** June 27, 2003

### We hereby certify that:

The above equipment was tested by C&C Laboratory Co., Ltd. The test data, data evaluation, test procedures, and equipment configurations shown in this report were made in accordance with the procedures given in ANSI C63.4 (1992) and the energy emitted by the sample EUT tested as described in this report is in compliance with conducted and radiated emission limits of FCC Rules Part 15.247.

The test results of this report relate only to the tested sample identified in this report.

*Approved By*

---

**Jonson Lee / Director**  
C&C Laboratory Co., Ltd.

*Reviewed By*

---

**Susan Su / Section Manager**  
C&C Laboratory Co., Ltd.



## Table of Contents

<b>1.</b>	<b>GENERAL INFORMATION .....</b>	<b>5</b>
1.1	PRODUCT DESCRIPTION .....	5
1.2	RELATED SUBMITTAL(S) / GRANT (S).....	5
1.3	TEST METHODOLOGY.....	5
1.4	TEST FACILITY .....	5
1.5	SPECIAL ACCESSORIES .....	5
1.6	EQUIPMENT MODIFICATIONS .....	5
<b>2.</b>	<b>SYSTEM TEST CONFIGURATION .....</b>	<b>6</b>
2.1	EUT CONFIGURATION.....	6
2.2	EUT EXERCISE.....	6
2.3	TEST PROCEDURE.....	6
2.4	CONFIGURATION OF TESTED SYSTEM.....	7
<b>3.</b>	<b>SUMMARY OF TEST RESULTS .....</b>	<b>8</b>
<b>4.</b>	<b>DESCRIPTION OF TEST MODES .....</b>	<b>8</b>
<b>5.</b>	<b>SPURIOUS EMISSION TEST .....</b>	<b>9</b>
5.1	STANDARD APPLICABLE .....	9
5.2	EUT SETUP .....	9
5.3	MEASUREMENT PROCEDURE.....	9
5.4	TEST SET-UP (BLOCK DIAGRAM OF CONFIGURATION).....	10
5.5	MEASUREMENT EQUIPMENT USED: .....	11
5.6	MEASUREMENT RESULT .....	11
<b>6.</b>	<b>AC POWER LINE CONDUCTED EMISSION TEST .....</b>	<b>24</b>
6.1.	STANDARD APPLICABLE .....	24
6.2.	EUT SETUP .....	24
6.3.	MEASUREMENT PROCEDURE.....	24
6.4.	MEASUREMENT EQUIPMENT USED: .....	25
6.5.	MEASUREMENT RESULT .....	25
<b>7.</b>	<b>6 DB BANDWIDTH MEASUREMENT.....</b>	<b>28</b>
7.1	STANDARD APPLICABLE .....	28
7.2	MEASUREMENT EQUIPMENT USED: .....	28
7.3	TEST SETUP: .....	28
7.4	MEASUREMENT PROCEDURE.....	29
7.5	MEASUREMENT RESULT .....	29
<b>8.</b>	<b>PEAK OUTPUT POWER MEASUREMENT .....</b>	<b>32</b>
8.1	STANDARD APPLICABLE .....	32
8.2	TEST SETUP .....	32
8.3	MEASUREMENT EQUIPMENT USED: .....	32
8.4	TEST RESULTS:.....	32



**9. 100KHZ BANDWIDTH OF BAND EDGES MEASUREMENT..... 35**

9.1 STANDARD APPLICABLE ..... 35

9.2 MEASUREMENT PROCEDURE..... 35

9.3 MEASUREMENT RESULT ..... 35

9.4 MEASUREMENT EQUIPMENT USED: ..... 35

**10. PEAK POWER SPECTRAL DENSITY ..... 37**

10.1 STANDARD APPLICABLE ..... 37

10.2 MEASUREMENT PROCEDURE..... 37

10.3 MEASUREMENT RESULT ..... 37

10.4 MEASUREMENT EQUIPMENT USED: ..... 37

**11. ANTENNA REQUIREMENT ..... 40**

11.1 STANDARD APPLICABLE ..... 40

11.2 ANTENNA CONNECTED CONSTRUCTION ..... 40

**12. RF EXPOSURE..... 41**

12.1 STANDARD APPLICABLE ..... 41

**APPENDIX 1 PHOTOGRPHS OF SET UP ..... 42**

**APPENDIX 2 EXTERNAL PHOTOGRPHS OF EUT..... 45**

**APPENDIX 3 INTERNAL PHOTOGRPHS OF EUT ..... 48**



## 1. GENERAL INFORMATION

### 1.1 Product Description

AirVast Technology In. Model: WN220 / PN15 / CT-110 / WU022 (referred to as the EUT in this report) is a 802.11b WLAN USB Stick. The EUT is compliance with IEEE802.11b Standard.

A major technical descriptions of EUT is described as following:

- A). Operation Frequency: 2.412GHz – 2.462GHz; 11 channels;
- B). Transmit Power: 13.15 dBm
- C). Modulation type: Direct Sequence Spread Spectrum, (CCK; DQPSK; DBPSK)
- D). Transition Speed: 1/2/5.5/11Mbps
- E). Antenna Designation: CHIP Antenna, 1.196 dBi, Non-User Replaceable
- F). Power Supply: from the PC USB port

### 1.2 Related Submittal(s) / Grant (s)

This submittal(s) (test report) is intended for FCC ID: QDWWN220 filing to comply with Section 15.247 of the FCC Part 15, Subpart C Rules. The composite system (digital device) is compliance with Subpart B is authorized under a DoC procedure.

### 1.3 Test Methodology

Both conducted and radiated testing was performed according to the procedures in ANSI C63.4 (1992). Radiated testing was performed at an antenna to EUT distance 3 meters.

### 1.4 Test Facility

The open area test site and conducted measurement facility used to collect the radiated data is located on the address of C&C Laboratory, Co., Ltd. No. 81-1, 210 Lane, Pa-de 2nd Road, Lu-Chu Hsiang, Taoyuan, Taiwan, R.O.C.. The Open Area Test Sites and the Line Conducted labs are constructed and calibrated to meet the FCC requirements in documents ANSI C63.4: 1992 and CISPR 22/EN 55022 requirements.

### 1.5 Special Accessories

Not available for this EUT intended for grant.

### 1.6 Equipment Modifications

Not available for this EUT intended for grant.

## **2. SYSTEM TEST CONFIGURATION**

### **2.1 EUT Configuration**

The EUT configuration for testing is installed on RF field strength measurement to meet the Commissions requirement and operating in a manner that intends to maximize its emission characteristics in a continuous normal application.

### **2.2 EUT Exercise**

The EUT (Transmitter) was operated in the engineering mode to fix the Tx frequency that was for the purpose of the measurements.

### **2.3 Test Procedure**

#### **2.3.1 Conducted Emissions**

The EUT is a placed on as turn table-which is 0.8 m above ground plane. According to the requirements in Section 13.1.4.1 of ANSI C63.4-1992. Conducted emissions from the EUT measured in the frequency range between 0.15 MHz and 30MHz using CISPR Quasi-Peak detector mode.

#### **2.3.2 Radiated Emissions**

The EUT is a placed on as turn table-which is 0.8 m above ground plane. The turn table shall rotate 360 degrees to determine the position of maximum emission level. EUT is set 3m away from the receiving antenna which varied from 1m to 4m to find out the highest emission. And also, each emission was to be maximized by changing the polarization of receiving antenna both horizontal and vertical. In order to find out the max. emission, the relative positions of this hand-held transmitter(EUT) was rotated through three orthogonal axes according to the requirements in Section 13.1.4.1 of ANSI C63.4-1992.

## 2.4 Configuration of Tested System

**Fig. 2-1 Configuration of Tested System**

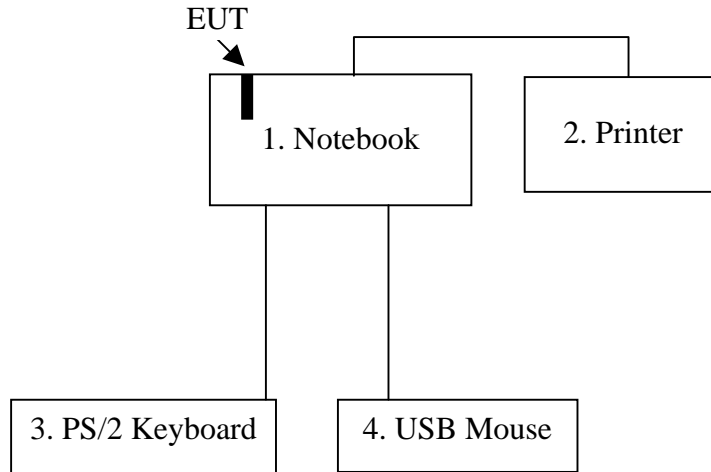

**Table 2-1 Equipment Used in Tested System**

Item	Equipment	Mfr/Brand	Model/ Type No.	FCC ID	Series No.	Data Cable	Power Cord
1.	Notebook	Compaq	PP2150	DoC	N/A	N/A	AC I/P: Unshielded, 1.8m DC O/P: Unshielded, 1.8m
2.	Printer	EPSON	EPSON STYLUS C20SX	N/A	DW4E130542	Shielded, 1.8m	Unshielded, 1.8m
3.	PS/2 Keyboard	Compaq	SK-2800C	GYUR79SK	B1C790BCPJ73JQ	Shielded, 1.8m	N/A
4.	USB Mouse	Logitech	M-BB48	FCC DoC	LZE92250259	Shielded, 1.8m	N/A



### 3. SUMMARY OF TEST RESULTS

FCC Rules	Description Of Test	Result
§ 15.209(a) (f)	Spurious Emission	Compliant
§ 15.207(a)	AC Power Port Conducted Emission	Compliant
§ 15.247(a)(2)	6dB Bandwidth	Compliant
§ 15.247(b)	Peak Output Power	Compliant
§ 15.247(c)	100 KHz Bandwidth Of Frequency Band Edges	Compliant
§ 15.247(d)	Power Density	Compliant
§ 15.203	Antenna Requirement	Compliant
§ 1.1310 and § 2.1093	RF exposures	Compliant

### 4. DESCRIPTION OF TEST MODES

The EUT has been tested under operating condition.

Software used to control the EUT for staying in continuous transmitting and receiving mode is programmed.

Channel 1(2412MHz)、 6(2437MHz) and 11(2462MHz) with 11Mbps highest data rate are chosen for full testing.



## 5. SPURIOUS EMISSION TEST

### 5.1 Standard Applicable

According to § 15.247(c), all other emissions outside these bands shall not exceed the general radiated emission limits specified in § 15.209(a). And according to § 15.33(a)(1), for an intentional radiator operates below 10GHz, the frequency range of measurements: to the tenth harmonic of the highest fundamental frequency or to 40GHz, whichever is lower.

### 5.2 EUT Setup

1. The radiated emission tests were performed in the 3 meters open-test site, using the setup in accordance with the ANSI C63.4-1992.
2. The EUT was put in the front of the test table. The host PC system was placed on the center of the back edge on the test table. The peripherals like modem, monitor, printer, K/B and mouse were placed on the side of the host PC system. The rear of the EUT and peripherals were placed flushed with the rear of the tabletop.
3. The keyboard was placed directly in the front of the monitor, flushed with the front tabletop. The mouse was placed next to the Keyboard, flushed with the back of keyboard.
4. The spacing between the peripherals was 10 centimeters.
5. External I/O cables were draped along the edge of the test table and bundle when necessary.
6. The host PC system was connected with 110Vac/60Hz power source.

### 5.3 Measurement Procedure

1. The EUT was placed on a turn table which is 0.8m above ground plane.
2. The turn table shall rotate 360 degrees to determine the position of maximum emission level.
3. EUT is set 3m away from the receiving antenna which varied from 1m to 4m to find out the highest emissions.
4. Maximum procedure was performed on the six highest emissions to ensure EUT compliance.
5. And also, each emission was to be maximized by changing the polarization of receiving antenna both horizontal and vertical.
6. Repeat above procedures until all frequency measured were complete.

### 5.4 Test SET-UP (Block Diagram of Configuration)

(A) Radiated Emission Test Set-Up, Frequency Below 1000MHz

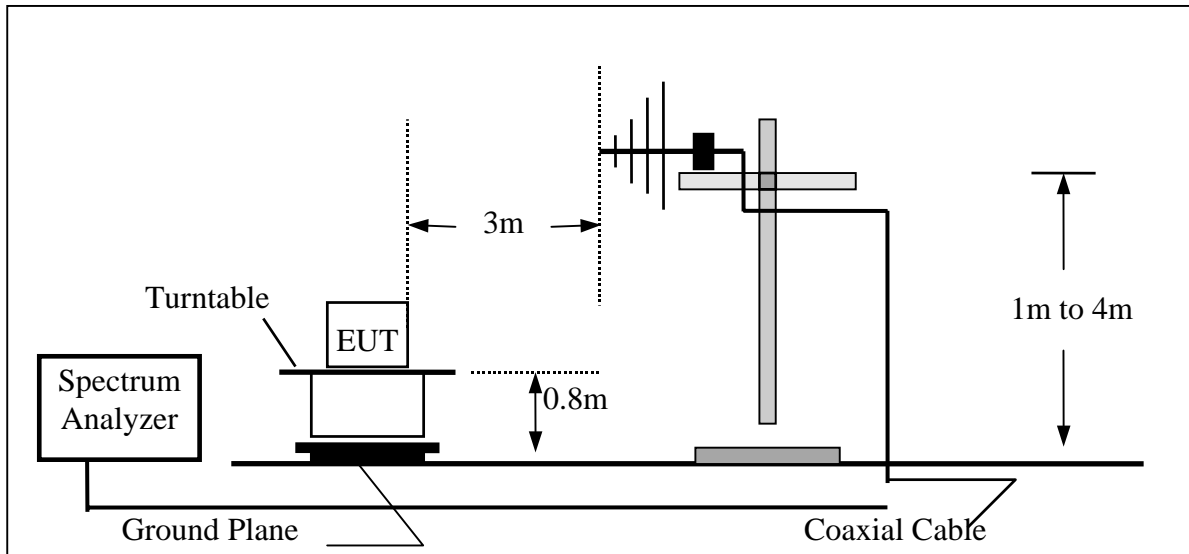

(B) Radiated Emission Test Set-UP Frequency Over 1 GHz

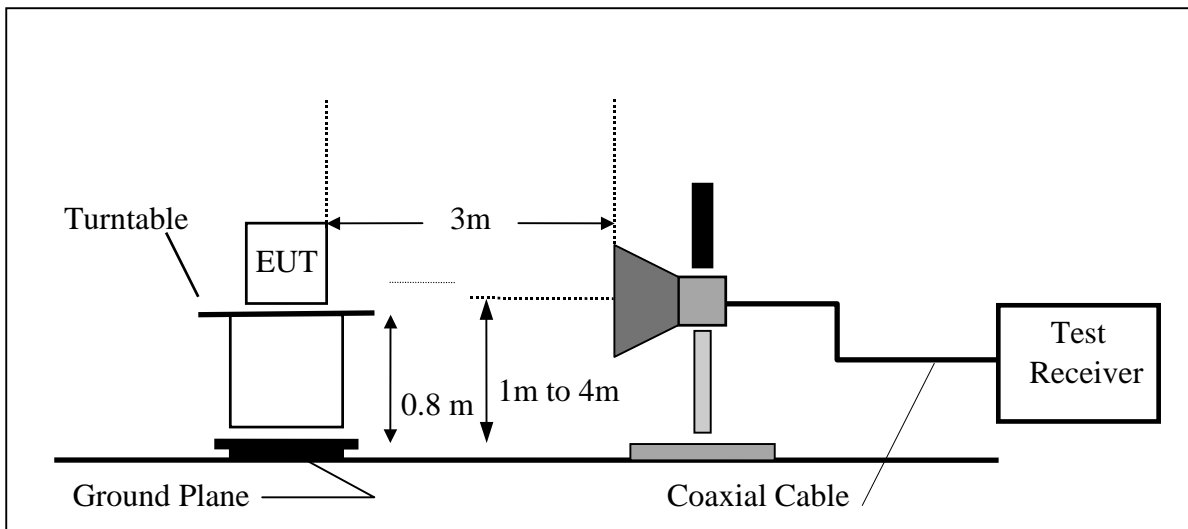



**5.5 Measurement Equipment Used:**

Open Area Test Site # 3					
EQUIPMENT TYPE	MFR	MODEL NUMBER	SERIAL NUMBER	LAST CAL.	CAL DUE.
Spectrum Analyzer	ADVANTEST	R3261A	N/A	03/19/2003	03/18/2004
EMI Test Receiver	R&S	ESVS20	838804/004	01/05/2003	01/04/2004
Pre-Amplifier	HP	8447D	2944A09173	03/04/2003	03/03/2004
Bilog Antenna	SCHWAZBECK	VULB9163	145	07/06/2002	07/05/2003
Turn Table	EMCO	2081-1.21	9709-1885	N.C.R	N.C.R
Antenna Tower	EMCO	2075-2	9707-2060	N.C.R	N.C.R
Controller	EMCO	2090	9709-1256	N.C.R	N.C.R
RF Switch	ANRITSU	MP59B	M53867	N.C.R	N.C.R
Site NSA	C&C	N/A	N/A	09/07/2002	09/06/2003
Horn antenna	Schwarzbeck	BBHA 9120	D210	02/24/2003	02/23/2004
Loop Antenna	EMCO	6502	2356	07/11/2002	07/10/2003
Pre-Amplifier	HP	8449B	3008B00965	10/01/2002	10/02/2003

**Field Strength Calculation**

The field strength is calculated by adding the Antenna Factor and Cable Factor and subtracting the Amplifier Gain and Duty Cycle Correction Factor (if any) from the measured reading. The basic equation with a sample calculation is as follows:

$$FS = RA + AF + CL - AG$$

Where	FS = Field Strength	CL = Cable Attenuation Factor (Cable Loss)
	RA = Reading Amplitude	AG = Amplifier Gain
	AF = Antenna Factor	

**5.6 Measurement Result**

Refer to attach tabular data sheets.

**NOTE:** The resolution bandwidth and video bandwidth of test receiver/spectrum analyzer is 100kHz for Peak detection (PK) and Quasi-peak detection (QP) at frequency below 1GHz.



## Conducted Spurious Emission Measurement Result

*Ch Low*

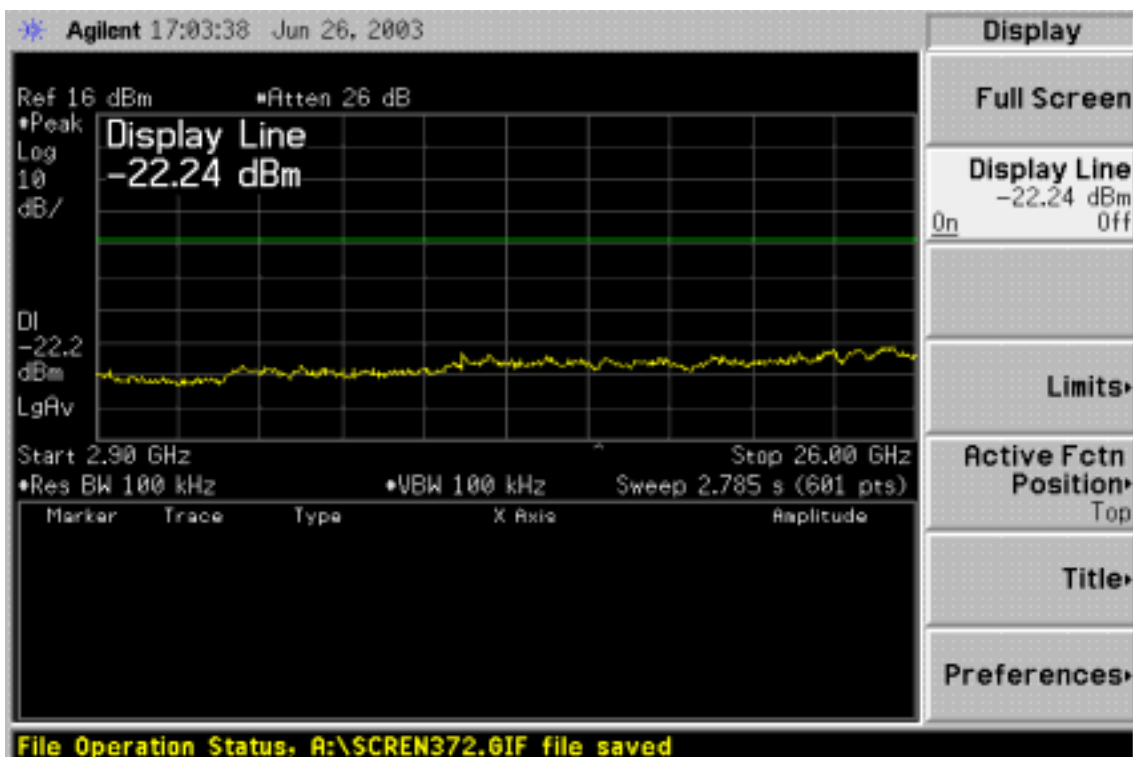
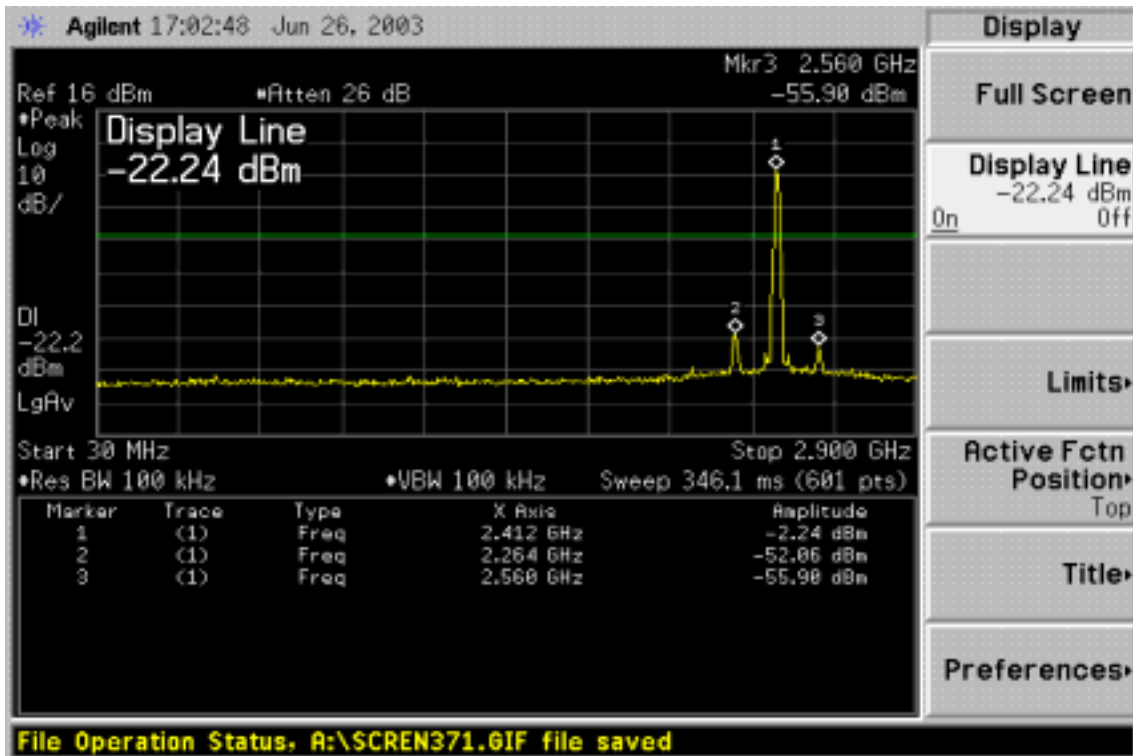



Ch Mid

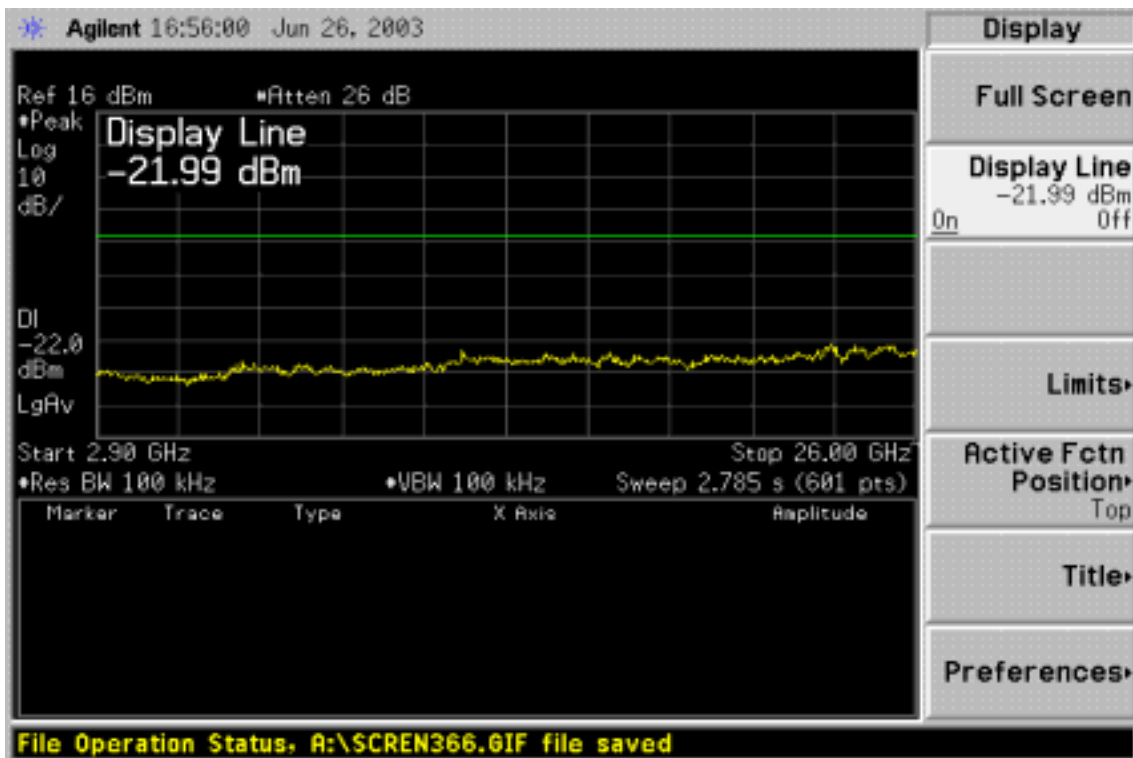
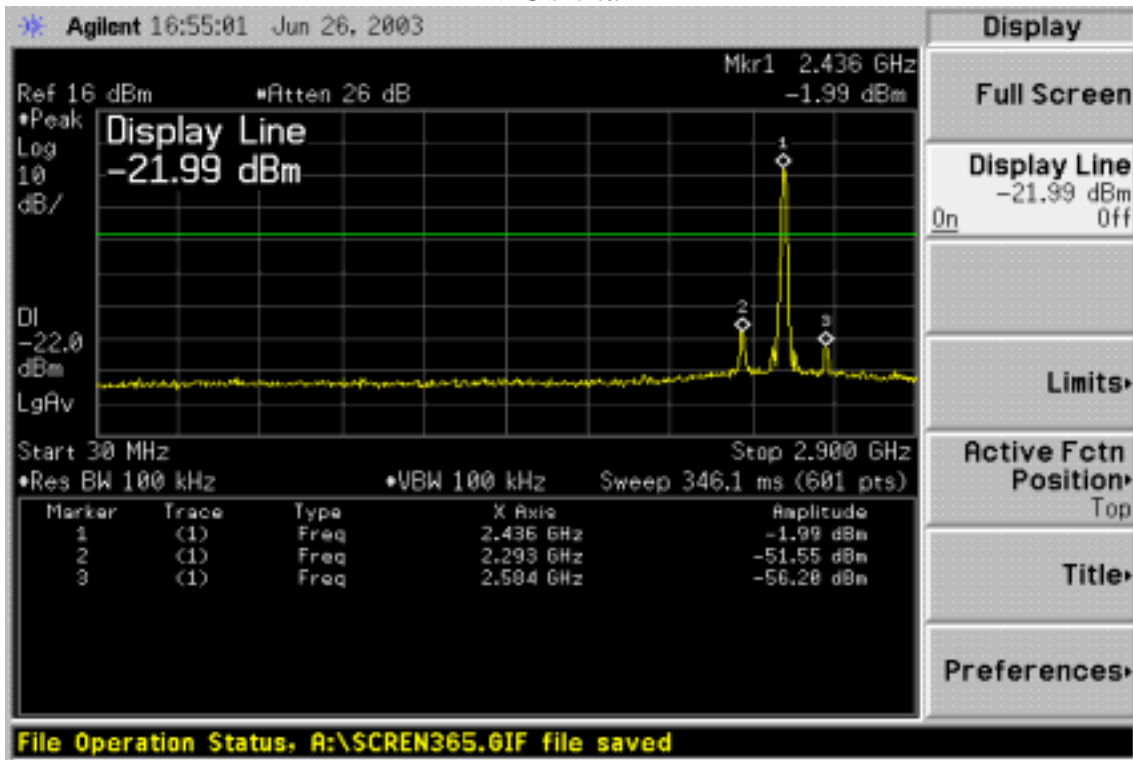



*Ch High*

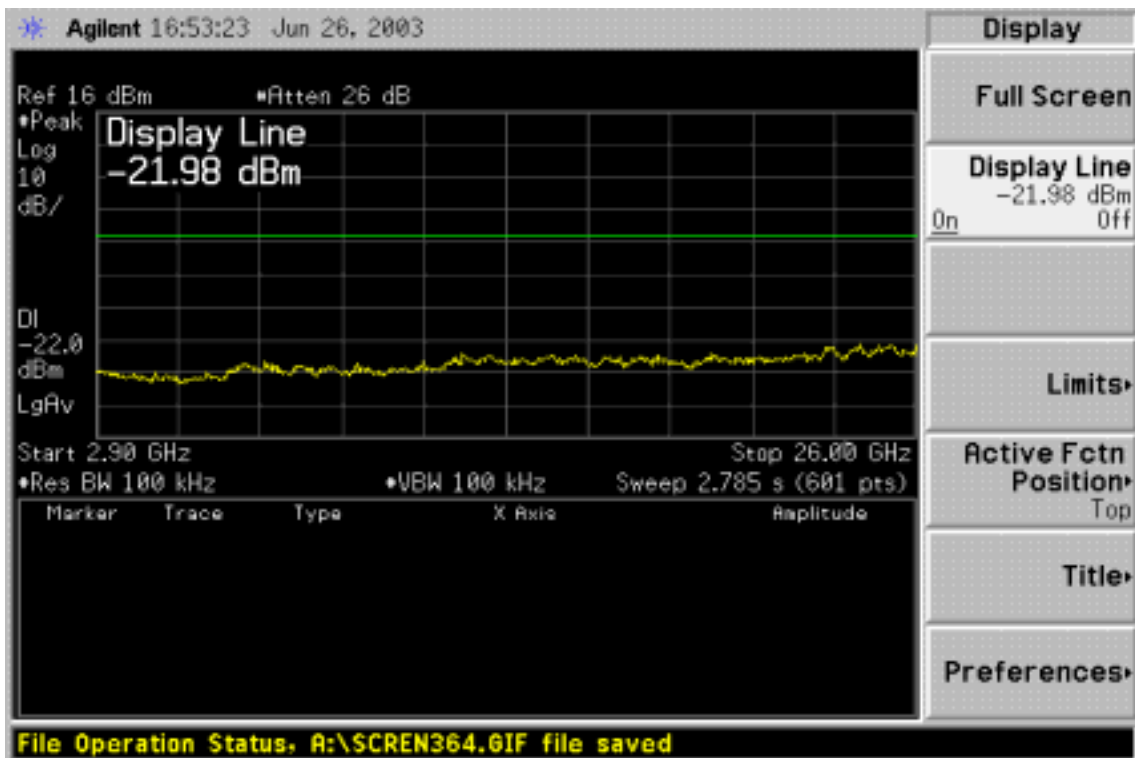
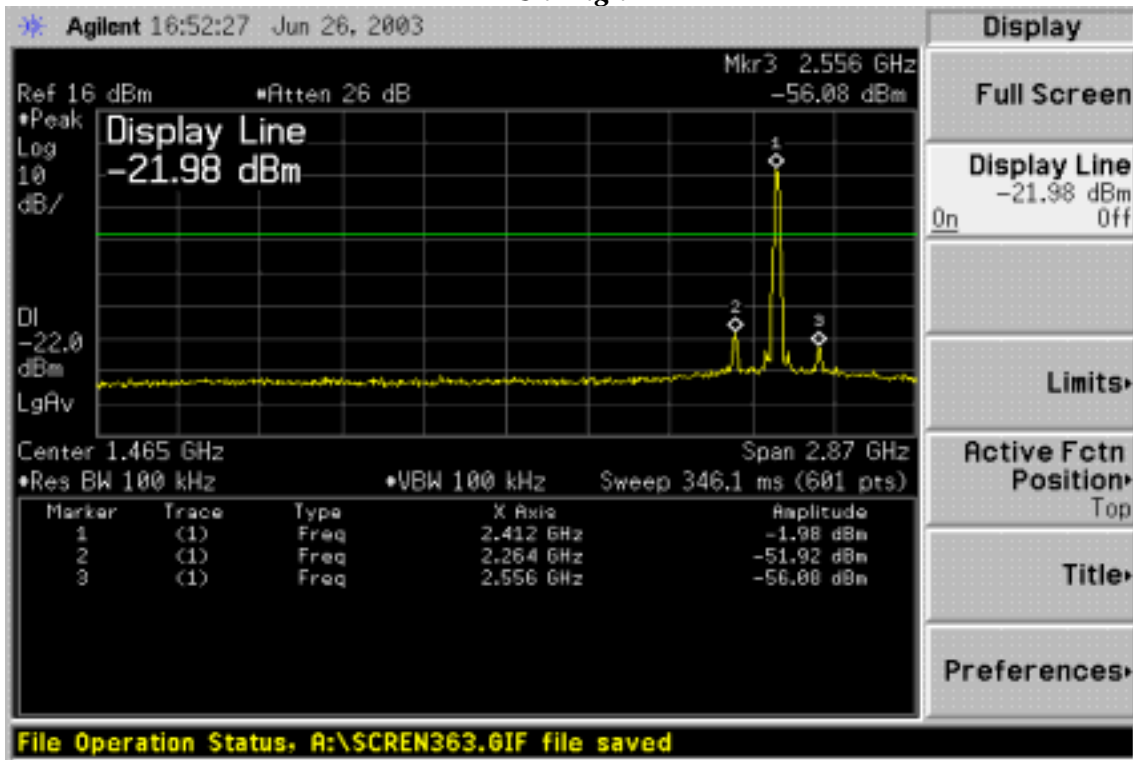



### Radiated Spurious Emission Measurement Result (below 1GHz)

Operation Mode: TX CH Low Mode      Test Date: June 27, 2003  
 Temperature: 20°C                      Test By: Ben  
 Humidity: 70 %                          Pol: Ver./Hor

Freq. (MHz)	Ant.Pol. H/V	Detector Mode (PK/QP)	Reading (dBuV)	Factor (dB)	Actual FS (dBuV/m)	Limit3m (dBuV/m)	Safe Margin (dB)
79.05	V	Peak	20.30	9.57	29.87	40.00	-10.13
195.60	V	Peak	23.31	14.48	37.79	43.50	-5.71
264.90	V	Peak	18.95	15.95	34.90	46.00	-11.10
344.33	V	Peak	22.09	17.88	39.97	46.00	-6.03
664.00	V	Peak	12.69	25.13	37.82	46.00	-8.18
786.50	V	Peak	13.85	26.07	39.92	46.00	-6.08
264.00	H	Peak	16.76	15.97	32.73	46.00	-13.27
344.33	H	Peak	19.42	17.88	37.30	46.00	-8.70
399.17	H	Peak	11.70	20.68	32.38	46.00	-13.62
622.83	H	Peak	11.21	25.11	36.32	46.00	-9.68
786.50	H	Peak	9.35	26.07	35.42	46.00	-10.58
926.50	H	Peak	4.93	28.53	33.46	46.00	-12.54

Remark :

- (1) Measuring frequencies from 30 MHz to the 1GHz.
- (2) Radiated emissions measured in frequency range from 30 MHz to 1000MHz were made with an instrument using Peak detector mode.
- (3) Datas of measurement within this frequency range shown “ - ” in the table above means the reading of emissions are attenuated more than 20dB below the permissible limits or the field strength is too small to be measured.
- (4) The IF bandwidth of SPA between 30MHz to 1GHz was 100KHz.



### Radiated Spurious Emission Measurement Result (below 1GHz)

Operation Mode:	TX CH Mid Mode	Test Date:	June 27, 2003
Temperature:	20°C	Test By:	Ben
Humidity:	70 %	Pol:	Ver./Hor

Freq. (MHz)	Ant.Pol. H/V	Detector Mode (PK/QP)	Reading (dBuV)	Factor (dB)	Actual FS (dBuV/m)	Limit3m (dBuV/m)	Safe Margin (dB)
132.60	V	Peak	21.19	11.13	32.32	43.50	-11.18
195.15	V	Peak	21.34	14.44	35.78	43.50	-7.72
260.40	V	Peak	18.51	16.06	34.57	46.00	-11.43
264.90	V	Peak	18.45	15.95	34.40	46.00	-11.60
344.33	V	Peak	22.92	17.88	40.80	46.00	-5.20
785.33	V	Peak	15.17	26.06	41.23	46.00	-4.77
344.33	H	Peak	20.26	17.88	38.14	46.00	-7.86
431.83	H	Peak	11.06	20.37	31.43	46.00	-14.57
422.33	H	Peak	12.13	20.25	32.38	46.00	-13.62
622.83	H	Peak	10.50	25.11	35.61	46.00	-10.39
785.33	H	Peak	10.01	26.06	36.07	46.00	-9.93
927.67	H	Peak	4.60	28.54	33.14	46.00	-12.86

Remark :

- (1) Measuring frequencies from 30 MHz to the 1GHz.
- (2) Radiated emissions measured in frequency range from 30 MHz to 1000MHz were made with an instrument using Peak detector mode.
- (3) Datas of measurement within this frequency range shown “ - ” in the table above means the reading of emissions are attenuated more than 20dB below the permissible limits or the field strength is too small to be measured.
- (4) The IF bandwidth of SPA between 30MHz to 1GHz was 100KHz.





### Radiated Spurious Emission Measurement Result (below 1GHz)

Operation Mode: TX CH High Mode      Test Date: June 27, 2003  
 Temperature: 20°C                      Test By: Ben  
 Humidity: 70 %                          Pol: Ver./Hor

Freq. (MHz)	Ant.Pol. H/V	Detector Mode (PK/QP)	Reading (dBuV)	Factor (dB)	Actual FS (dBuV/m)	Limit3m (dBuV/m)	Safe Margin (dB)
195.60	V	Peak	20.81	14.48	35.29	43.50	-8.21
260.40	V	Peak	21.84	16.06	37.90	46.00	-8.10
344.33	V	Peak	24.09	17.88	41.97	46.00	-4.03
433.50	V	Peak	18.19	20.24	38.43	46.00	-7.57
665.17	V	Peak	12.52	25.15	37.67	46.00	-8.33
786.50	V	Peak	15.85	26.07	41.92	46.00	-4.08
344.33	H	Peak	22.26	17.88	40.14	46.00	-5.86
431.83	H	Peak	12.90	20.37	33.27	46.00	-12.73
433.50	H	Peak	16.53	20.24	36.77	46.00	-9.23
665.17	H	Peak	8.18	25.15	33.33	46.00	-12.67
786.50	H	Peak	8.52	26.07	34.59	46.00	-11.41
931.16	H	Peak	6.47	28.59	35.06	46.00	-10.94

Remark :

- (1) Measuring frequencies from 30 MHz to the 1GHz.
- (2) Radiated emissions measured in frequency range from 30 MHz to 1000MHz were made with an instrument using Peak detector mode.
- (3) Datas of measurement within this frequency range shown “ - ” in the table above means the reading of emissions are attenuated more than 20dB below the permissible limits or the field strength is too small to be measured.
- (4) The IF bandwidth of SPA between 30MHz to 1GHz was 100KHz.



### Radiated Spurious Emission Measurement Result (Above 1GHz)

Operation Mode: TX CH Low Mode      Test Date: June 27, 2003  
 Temperature: 20°C                      Test By: Ben  
 Humidity: 70 %                          Pol: Vertical

Freq. (MHz)	Peak	AV	Ant./CL CF(dB)	Actual FS		Peak	AV	Margin (dB)	Remark
	Reading (dBuV)	Reading (dBuV)		Peak (dBuV/m)	AV (dBuV/m)	Limit (dBuV/m)	Limit (dBuV/m)		
2263	50.17	---	-3.50	46.67	---	74.00	54.00	-7.33	Peak
2553	46.50	---	-2.63	43.87	---	74.00	54.00	-10.13	Peak
4824	--					74.00	54.00		
7236	--					74.00	54.00		
9648	--					74.00	54.00		
12060	--					74.00	54.00		
14472	--					74.00	54.00		
16884	--					74.00	54.00		
19296	--					74.00	54.00		
21708	--					74.00	54.00		
24120	--					74.00	54.00		

Remark :

- (1) Measuring frequencies from 1 GHz to the 10th harmonic of highest fundamental frequency.
- (2) Datas of measurement within this frequency range shown “ - ” in the table above means the reading of emissions are attenuated more than 20dB below the permissible limits or the field strength is too small to be measured.
- (3) Radiated emissions measured in frequency above 1000MHz were made with an instrument using Peak detector mode and average detector mode of the emission shown in Actual FS column.
- (4) Spectrum Peak Setting 1GHz- 26GHz, RBW= 1MHz, VBW= 1MHz, Sweep time= 200 ms.  
 Spectrum AV Setting 1GHz- 26GHz, RBW= 1MHz, VBW= 10Hz, Sweep time= 200 ms.



### Radiated Spurious Emission Measurement Result (Above 1GHz)

Operation Mode: TX Low Mode      Test Date: June 27, 2003  
 Temperature: 20°C      Test By: Ben  
 Humidity: 70 %      Pol: Horizontal

Freq. (MHz)	Peak	AV	Ant./CL CF(dB)	Actual FS		Peak	AV	Margin (dB)	Remark
	Reading (dBuV)	Reading (dBuV)		Peak (dBuV/m)	AV (dBuV/m)	Limit (dBuV/m)	Limit (dBuV/m)		
2263	50.00	---	-3.50	46.50	---	74.00	54.00	-7.50	Peak
5716	39.50	---	4.93	44.43	---	74.00	54.00	-9.57	Peak
4824	--					74.00	54.00		
7236	--					74.00	54.00		
9648	--					74.00	54.00		
12060	--					74.00	54.00		
14472	--					74.00	54.00		
16884	--					74.00	54.00		
19296	--					74.00	54.00		
21708	--					74.00	54.00		
24120	--					74.00	54.00		

Remark :

- (1) Measuring frequencies from 1 GHz to the 10th harmonic of highest fundamental frequency.
- (2) Datas of measurement within this frequency range shown “ - ” in the table above means the reading of emissions are attenuated more than 20dB below the permissible limits or the field strength is too small to be measured.
- (3) Radiated emissions measured in frequency above 1000MHz were made with an instrument using Peak detector mode and average detector mode of the emission shown in Actual FS column.
- (4) Spectrum Peak Setting 1GHz- 26GHz, RBW= 1MHz, VBW= 1MHz, Sweep time= 200 ms.  
 Spectrum AV Setting 1GHz- 26GHz, RBW= 1MHz, VBW= 10Hz, Sweep time= 200 ms.



### Radiated Spurious Emission Measurement Result (Above 1GHz)

Operation Mode: TX Mid Mode      Test Date: June 27, 2003  
 Temperature: 20°C      Test By: Ben  
 Humidity: 70 %      Pol: Vertical

Freq. (MHz)	Peak	AV	Ant./CL CF(dB)	Actual FS		Peak	AV	Margin (dB)	Remark
	Reading (dBuV)	Reading (dBuV)		Peak (dBuV/m)	AV (dBuV/m)	Limit (dBuV/m)	Limit (dBuV/m)		
2293	49.50	---	-3.40	46.10	---	74.00	54.00	-7.90	Peak
2580	45.84	---	-2.57	43.27	---	74.00	54.00	-10.73	Peak
4874	--					74.00	54.00		
7311	--					74.00	54.00		
9748	--					74.00	54.00		
12185	--					74.00	54.00		
14622	--					74.00	54.00		
17059	--					74.00	54.00		
19496	--					74.00	54.00		
21933	--					74.00	54.00		
24370	--					74.00	54.00		

Remark :

- (1) Measuring frequencies from 1 GHz to the 10th harmonic of highest fundamental frequency.
- (2) Datas of measurement within this frequency range shown “ - ” in the table above means the reading of emissions are attenuated more than 20dB below the permissible limits or the field strength is too small to be measured.
- (3) Radiated emissions measured in frequency above 1000MHz were made with an instrument using Peak detector mode and average detector mode of the emission shown in Actual FS column.
- (4) Spectrum Peak Setting 1GHz- 26GHz, RBW= 1MHz, VBW= 1MHz, Sweep time= 200 ms.  
 Spectrum AV Setting 1GHz- 26GHz, RBW= 1MHz, VBW= 10Hz, Sweep time= 200 ms.



### Radiated Spurious Emission Measurement Result (Above 1GHz)

Operation Mode: TX Mid Mode      Test Date: June 27, 2003  
 Temperature: 20°C      Test By: Ben  
 Humidity: 70 %      Pol: Horizontal

Freq. (MHz)	Peak	AV	Ant./CL CF(dB)	Actual FS		Peak	AV	Margin (dB)	Remark
	Reading (dBuV)	Reading (dBuV)		Peak (dBuV/m)	AV (dBuV/m)	Limit (dBuV/m)	Limit (dBuV/m)		
2286	49.34	---	-3.42	45.92	---	74.00	54.00	-8.08	Peak
4866	40.50	---	3.38	43.88	---	74.00	54.00	-10.12	Peak
4874	--					74.00	54.00		
7311	--					74.00	54.00		
9748	--					74.00	54.00		
12185	--					74.00	54.00		
14622	--					74.00	54.00		
17059	--					74.00	54.00		
19496	--					74.00	54.00		
21933	--					74.00	54.00		
24370	--					74.00	54.00		

Remark :

- (1) Measuring frequencies from 1 GHz to the 10th harmonic of highest fundamental frequency.
- (2) Datas of measurement within this frequency range shown “ - ” in the table above means the reading of emissions are attenuated more than 20dB below the permissible limits or the field strength is too small to be measured.
- (3) Radiated emissions measured in frequency above 1000MHz were made with an instrument using Peak detector mode and average detector mode of the emission shown in Actual FS column.
- (4) Spectrum Peak Setting 1GHz- 26GHz, RBW= 1MHz, VBW= 1MHz, Sweep time= 200 ms.  
 Spectrum AV Setting 1GHz- 26GHz, RBW= 1MHz, VBW= 10Hz, Sweep time= 200 ms.



### Radiated Spurious Emission Measurement Result (Above 1GHz)

Operation Mode: TX High Mode      Test Date: June 27, 2003  
 Temperature: 20°C      Test By: Ben  
 Humidity: 70 %      Pol: Vertical

Freq. (MHz)	Peak	AV	Ant./CL CF(dB)	Actual FS		Peak	AV	Margin (dB)	Remark (dB)
	Reading (dBuV)	Reading (dBuV)		Peak (dBuV/m)	AV (dBuV/m)	Limit (dBuV/m)	Limit (dBuV/m)		
2316	50.17	---	-3.32	46.85	---	74.00	54.00	-7.15	Peak
4916	43.50	---	3.49	46.99	---	74.00	54.00	-7.01	Peak
4924	--					74.00	54.00		
7386	--					74.00	54.00		
9848	--					74.00	54.00		
12310	--					74.00	54.00		
14772	--					74.00	54.00		
17234	--					74.00	54.00		
19696	--					74.00	54.00		
22158	--					74.00	54.00		
24620	--					74.00	54.00		

Remark :

- (1) Measuring frequencies from 1 GHz to the 10th harmonic of highest fundamental frequency.
- (2) Datas of measurement within this frequency range shown “ - ” in the table above means the reading of emissions are attenuated more than 20dB below the permissible limits or the field strength is too small to be measured.
- (3) Radiated emissions measured in frequency above 1000MHz were made with an instrument using Peak detector mode and average detector mode of the emission shown in Actual FS column.
- (4) Spectrum Peak Setting 1GHz- 26GHz, RBW= 1MHz, VBW= 1MHz, Sweep time= 200 ms.  
 Spectrum AV Setting 1GHz- 26GHz, RBW= 1MHz, VBW= 10Hz, Sweep time= 200 ms.



### Radiated Spurious Emission Measurement Result (Above 1GHz)

Operation Mode: TX High Mode      Test Date: June 27, 2003  
 Temperature: 20°C      Test By: Ben  
 Humidity: 70 %      Pol: Horizontal

Freq. (MHz)	Peak	AV	Ant./CL CF(dB)	Actual FS		Peak	AV	Margin (dB)	Remark (dB)
	Reading (dBuV)	Reading (dBuV)		Peak (dBuV/m)	AV (dBuV/m)	Limit (dBuV/m)	Limit (dBuV/m)		
2313	50.00	---	-3.33	46.67	---	74.00	54.00	-7.33	Peak
4924	--					74.00	54.00		
7386	--					74.00	54.00		
9848	--					74.00	54.00		
12310	--					74.00	54.00		
14772	--					74.00	54.00		
17234	--					74.00	54.00		
19696	--					74.00	54.00		
22158	--					74.00	54.00		
24620	--					74.00	54.00		

Remark :

- (1) Measuring frequencies from 1 GHz to the 10th harmonic of highest fundamental frequency.
- (2) Datas of measurement within this frequency range shown “ - ” in the table above means the reading of emissions are attenuated more than 20dB below the permissible limits or the field strength is too small to be measured.
- (3) Radiated emissions measured in frequency above 1000MHz were made with an instrument using Peak detector mode and average detector mode of the emission shown in Actual FS column.
- (4) Spectrum Peak Setting 1GHz- 26GHz, RBW= 1MHz, VBW= 1MHz, Sweep time= 200 ms.  
 Spectrum AV Setting 1GHz- 26GHz, RBW= 1MHz, VBW= 10Hz, Sweep time= 200 ms.



## 6. AC POWER LINE CONDUCTED EMISSION TEST

### 6.1. Standard Applicable

According to § 15.207. frequency within 150KHz to 30MHz shall not exceed

Frequency range MHz	Limits dB(uV)	
	Quasi-peak	Average
0.15 to 0.50	66 to 56	56 to 46
0.50 to 5	56	46
5 to 30	60	50

Note  
 1.The lower limit shall apply at the transition frequencies  
 2.The limit decreases linearly with the logarithm of the frequency in the range 0.15 MHz to 0.50 MHz.

### 6.2. EUT Setup

1. The conducted emission tests were performed in the test site, using the setup in accordance with the ANSI C63.4-1992.
2. The EUT was plug-in the host PC via USB port. The host PC system was placed on the center of the back edge on the test table. The peripherals like modem, monitor printer, K/B, and mouse were placed on the side of the host PC system. The rear of the EUT and peripherals were placed flushed with the rear of the tabletop.
3. The keyboard was placed directly in the front of the monitor, flushed with the front tabletop. The mouse was placed next to the Keyboard, flushed with the back of keyboard.
4. The spacing between the peripherals was 10 centimeters.
5. External I/O cables were draped along the edge of the test table and bundle when necessary.
6. The host PC system was connected with 110Vac/60Hz power source.

### 6.3. Measurement Procedure

1. The EUT was placed on a table which is 0.8m above ground plane.
2. Maximum procedure was performed on the six highest emissions to ensure EUT compliance.
3. Repeat above procedures until all frequency measured were complete.





**6.4. Measurement Equipment Used:**

<b>Conducted Emission Test Site # 3</b>					
<b>EQUIPMENT TYPE</b>	<b>MFR</b>	<b>Model No.</b>	<b>Serial No.</b>	<b>LAST CAL.</b>	<b>Cal. Due.</b>
EMI Test Receiver	R&S	ESCS30	847793/012	12/21/2002	12/20/2003
LISN	R&S	ESH2-Z5	843285/010	12/16/2002	12/15/2003
LISN	EMCO	3825/2	9003-1628	07/26/2002	07/25/2003

**6.5. Measurement Result**

The initial step in collecting conducted data is a spectrum analyzer peak scan of the measurement range. Significant peaks are then marked as shown on the following data page, and these signals are then quasi-peaked.



## AC POWER LINE CONDUCTED EMISSION TEST

Operation Mode:	TX + RX Mode			Test Date:	June 27, 2003
Temperature:	22°C	Humidity:	70%	Test By:	Ben

FREQ MHz	Q.P. Raw dBuV	AVG Raw dBuV	Q.P. Limit dBuV	AVG Limit dBuV	Q.P. Margin dB	AVG Margin dB	NOTE
0.162	59.73	46.99	65.36	55.36	-5.63	-8.37	L1
0.251	50.39	39.74	61.72	51.72	-11.33	-11.98	L1
0.331	40.68	37.89	59.43	49.43	-18.75	-11.54	L1
0.414	44.38	36.30	57.57	47.57	-13.19	-11.27	L1
0.494	43.95	31.26	56.10	46.10	-12.15	-14.84	L1
4.593	47.82	30.50	56.00	46.00	-8.18	-15.50	L1
0.261	49.89	40.85	61.40	51.40	-11.51	-10.55	L2
0.519	44.43	34.60	56.00	46.00	-11.57	-11.40	L2
0.689	45.00	37.48	56.00	46.00	-11.00	-8.52	L2
0.951	45.00	33.09	56.00	46.00	-11.00	-12.91	L2
1.213	44.84	29.98	56.00	46.00	-11.16	-16.02	L2
1.454	45.50	30.14	56.00	46.00	-10.50	-15.86	L2

Remark :

- (1) Measuring frequencies from 0.15 MHz to 30MHz.
- (2) The emissions measured in frequency range from 0.15 MHz to 30MHz were made with an instrument using Quasi-Peak detector and Average detector.
- (3) “---” denotes the emission level was or more than 2dB below the Average limit, so no re-check anymore.
- (4) The IF bandwidth of SPA between 0.15MHz to 30MHz was 10KHz;  
 The IF bandwidth of Test Receiver between 0.15MHz to 30MHz was 9KHz;
- (5) L1 = Line One (Line live side) / L2 = Line Two (Neutral live side)



### Conducted Test Data

#### LINE 1

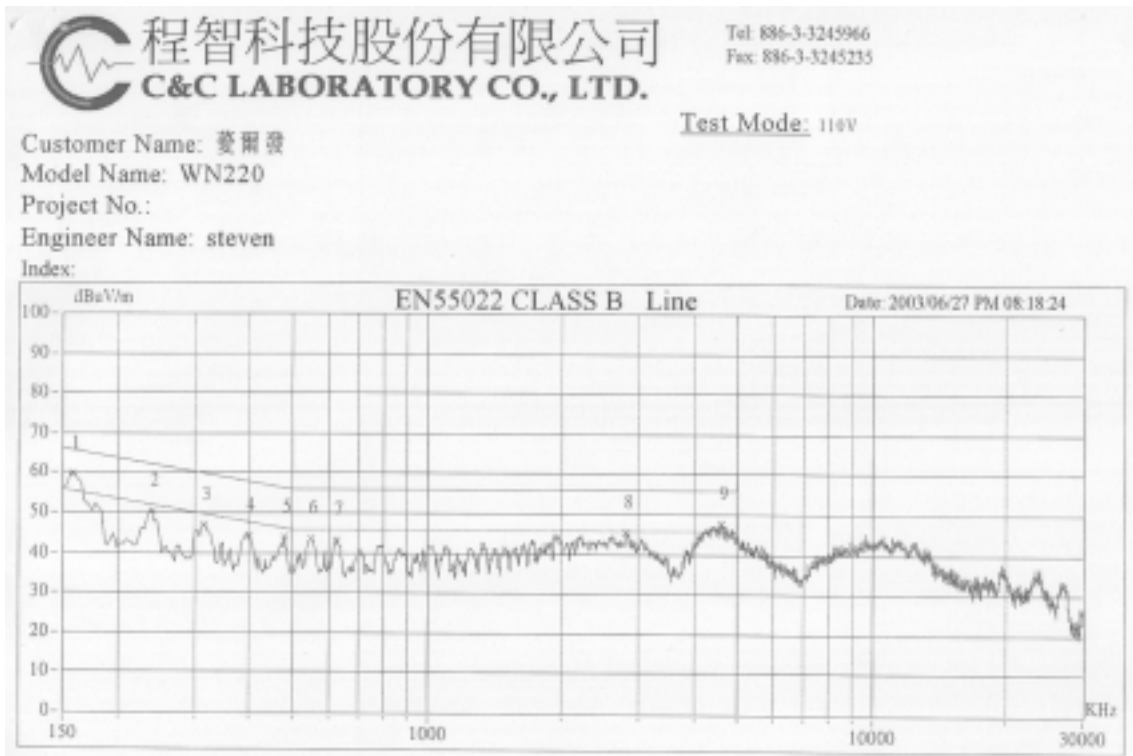

#### LINE 2

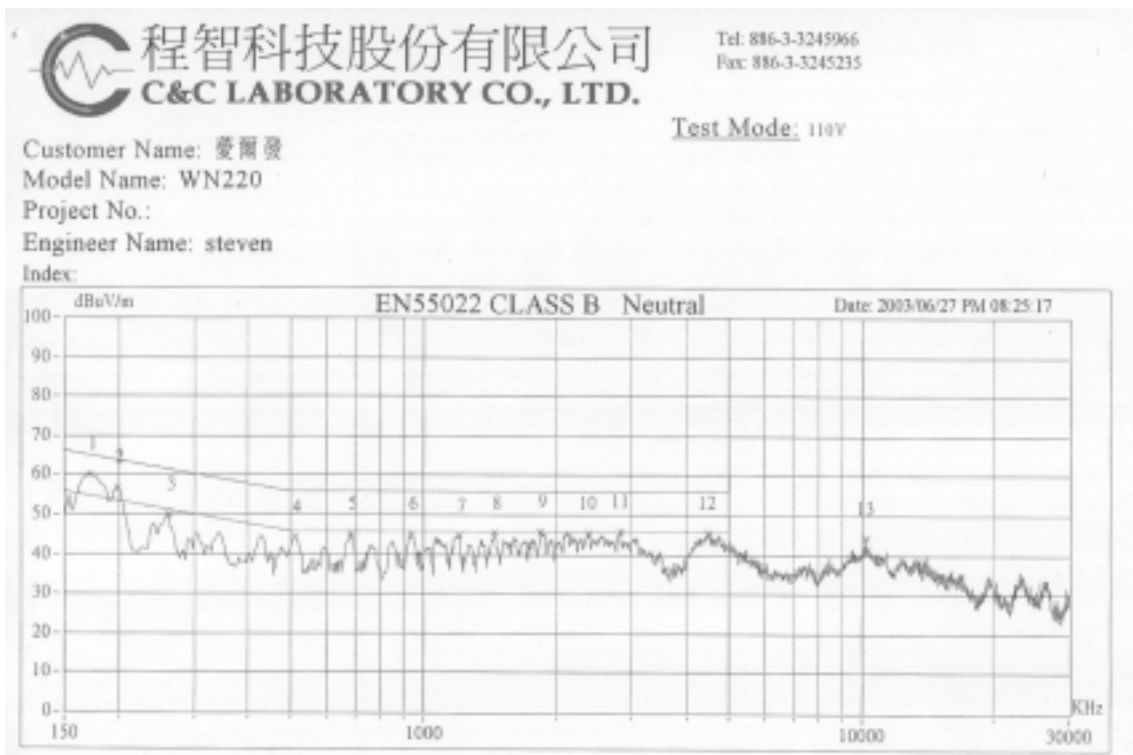

## 7. 6 dB Bandwidth Measurement

### 7.1 Standard Applicable

According to § 15.247(a)(2), DSSS Systems operating in the 2400MHz-2483.5MHz and 5725MHz – 5850MHz bands. The Minimum 6dB bandwidth shall be at least 500KHz.

### 7.2 Measurement Equipment Used:

EQUIPMENT TYPE	MFR	Model No.	Serial No.	LAST CAL.	Cal. Due.
Spectrum Analyzer	Advantest	R3182	110600647	11/16/2002	11/15/2003
Spectrum Analyzer	R&S	FSP30	1093.4495.30	07/23/2002	07/22/2003
low loss cable	Huber + Suhner	Sucoflex 104	N/A	N/A	N/A

### 7.3 Test Setup:

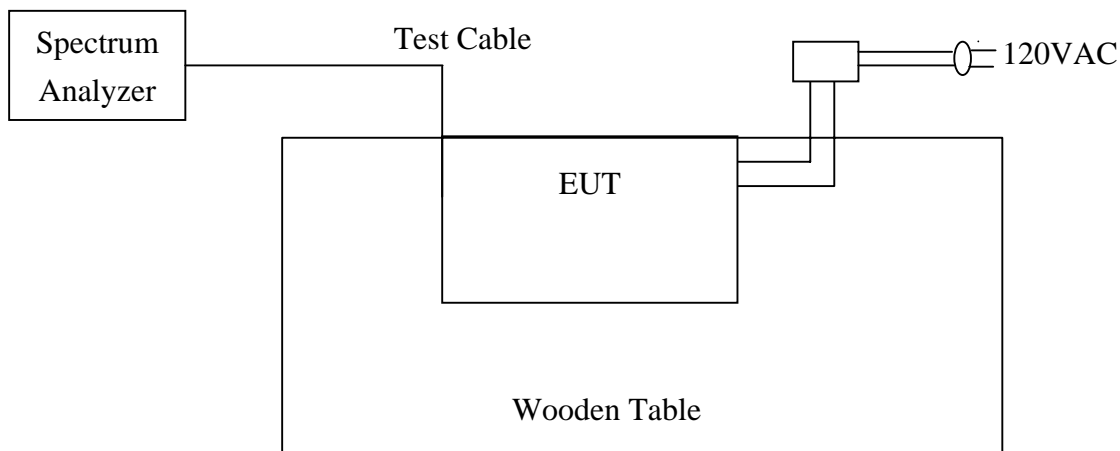

**Fig. 4**

**Fig. 4:** Measurement setup for testing on Antenna connector



#### 7.4 Measurement Procedure

1. Place the EUT on the table and set it in transmitting mode.
2. Remove the antenna from the EUT and then connect a low loss RF cable from the antenna port to the spectrum analyzer.
3. Set the spectrum analyzer as RBW=100KHz, VBW = RBW, Span= 20MHz, Sweep=auto
4. Mark the peak frequency and -6dB (upper and lower) frequency.
5. Repeat above procedures until all frequency measured were complete.

#### 7.5 Measurement Result

Channel	Bandwidth(MHz)	Bandwidth (KHz)	Result
Low	12.14	> 500	PASS
Mid	12.14	> 500	PASS
High	12.17	> 500	PASS



### 6dB Band Width Test Data CH-Low

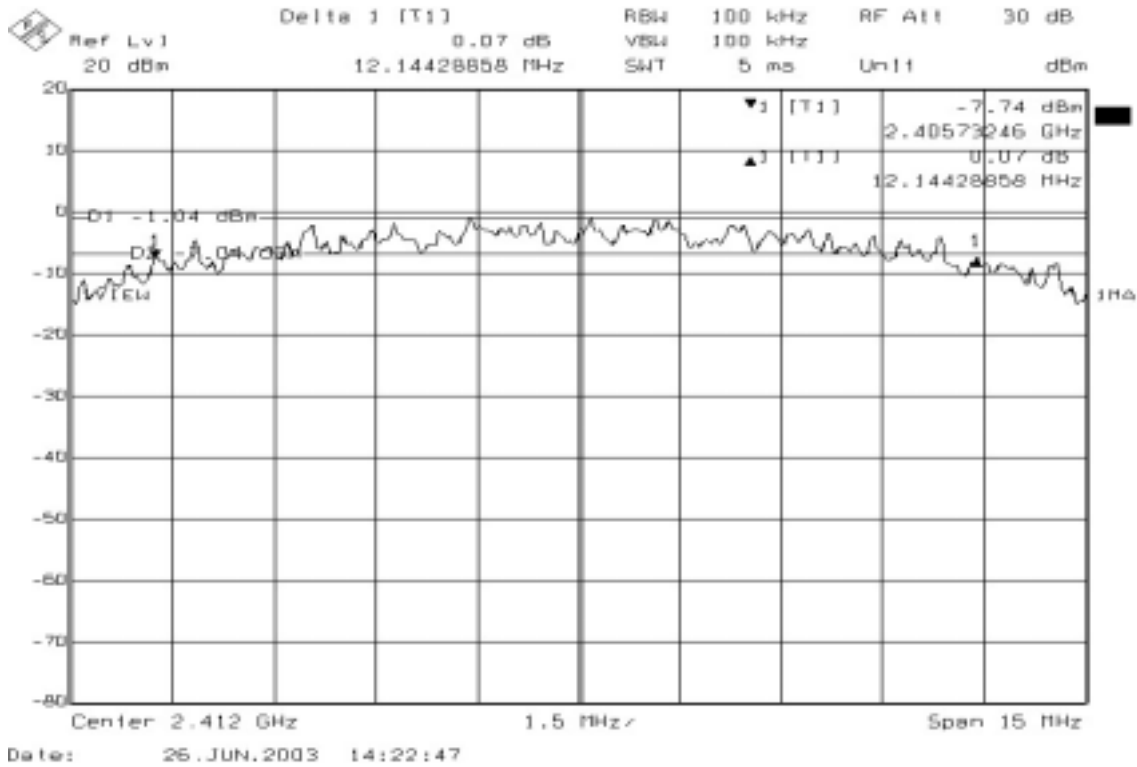

### 6dB Band Width Test Data CH-Mid

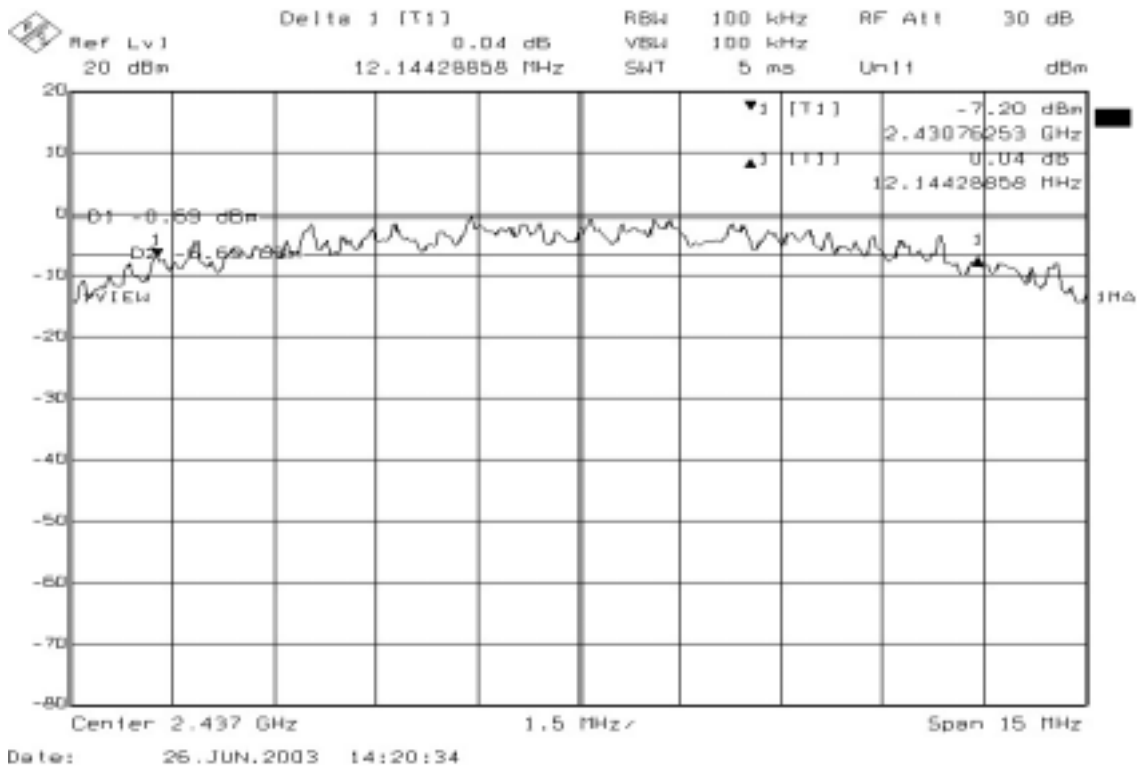



### 6dB Band Width Test Data CH-High

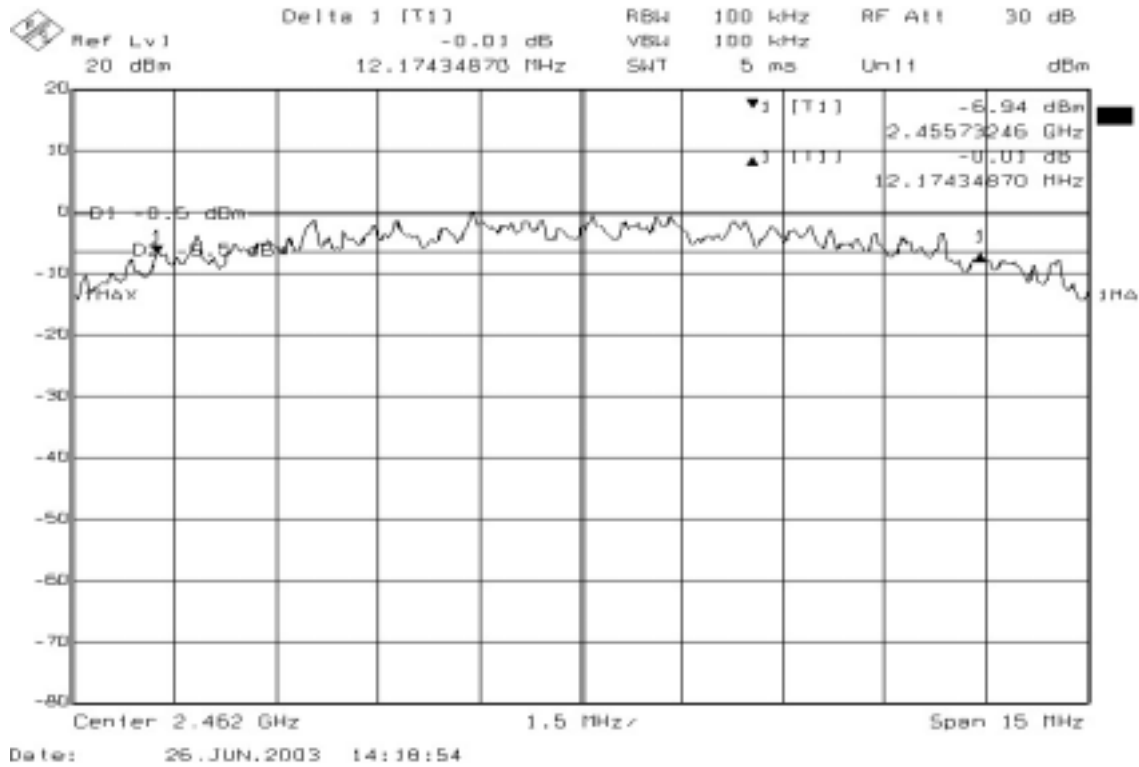

## 8. PEAK OUTPUT POWER MEASUREMENT

### 8.1 Standard Applicable

According to § 15.247(b)(2), for direct sequence systems, the maximum peak output power of the intentional radiator shall not exceed 1 Watt.

### 8.2 Test Setup

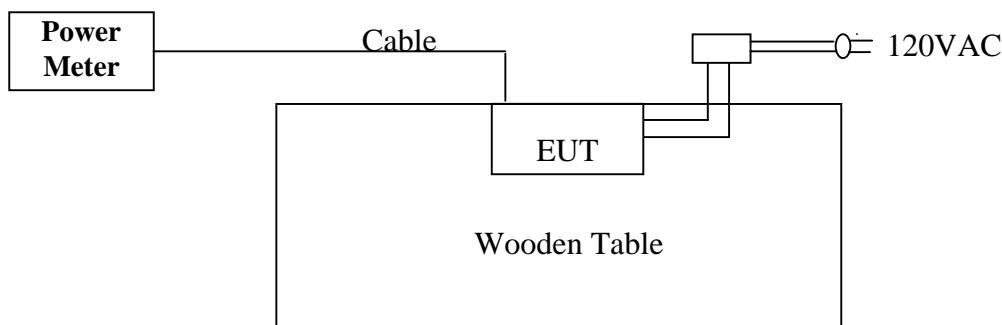

### 8.3 Measurement Equipment Used:

EQUIPMENT TYPE	MFR	Model No.	Serial No.	LAST CAL.	Cal. Due.
RF Power Meter	BOONTON	4531	130601	01/11/2003	01/10/2004
Power Sensor	Agilent	8481A	2702A61366	3/16/2003	3/15/2004
low loss cable	Huber + Suhner	Sucoflex 104	N/A	N/A	N/A

### 8.4 Test Results:

Channel	Reading Power (dBm)	Cable Loss (dB)	Output Power (dBm)	Output Power (W)	Limit (W)	Result
Low	10.58	2.50	13.08	0.02032	1	PASS
Mid	10.65	2.50	13.15	0.02065	1	PASS
High	10.60	2.50	13.10	0.02042	1	PASS





### OUTPUT POWER Width Test Data CH-Low



### OUTPUT POWER Test Data CH-Mid

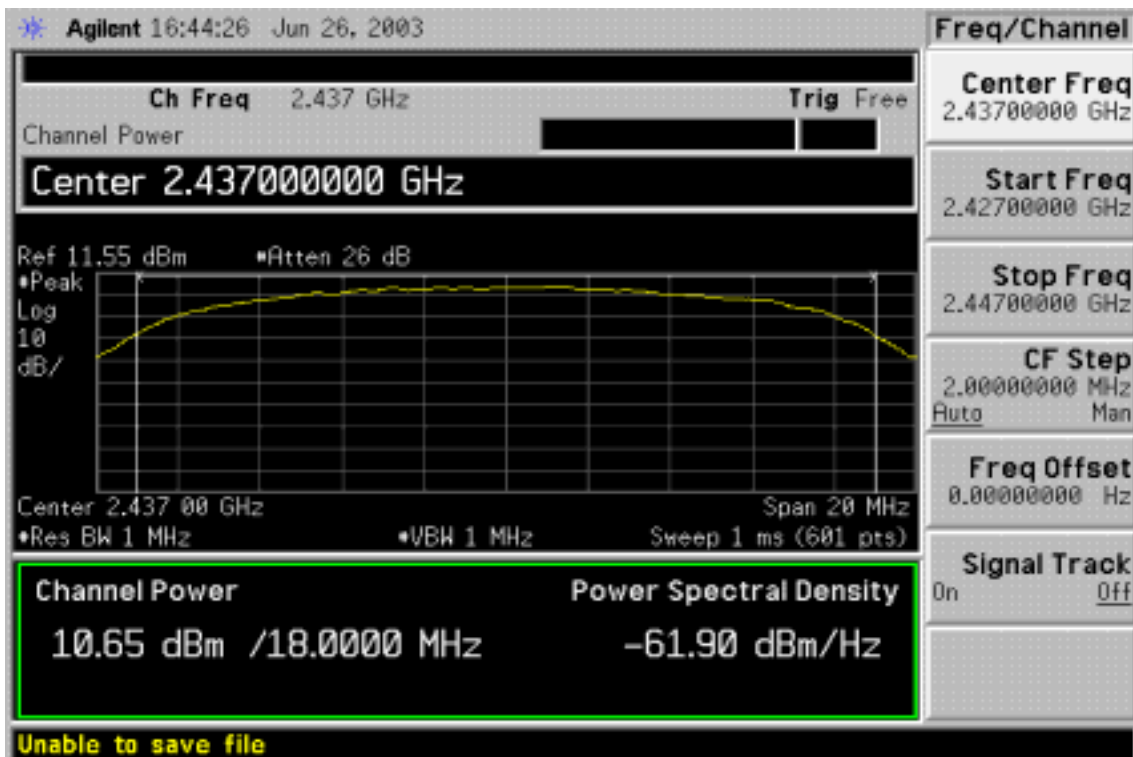



### OUTPUT POWER Test Data CH-High





## 9. 100KHz BANDWIDTH OF BAND EDGES MEASUREMENT

### 9.1 Standard Applicable

According to § 15.247(c), in any 100 KHz bandwidth outside the frequency bands in which the spread spectrum intentional radiator is operating, the radio frequency power that is produced by the intentional radiator shall be at least 20dB below that in the 100KHz bandwidth within the band that contains the highest level of the desired power, In addition, radiated emissions which fall in the restricted bands, as defined in § 15.205(a), must also comply with the radiated emission limits specified in 15.209(a).

### 9.2 Measurement Procedure

1. Place the EUT on the table and set it in transmitting mode.
2. Remove the antenna from the EUT and then connect a low loss RF cable from the antenna port to the spectrum analyzer.
3. Set center frequency of spectrum analyzer = operating frequency.
4. Set the spectrum analyzer as RBW, VBW=100KHz, Center Freq. 2.39GHz, 2.4835GHz, Span=100MHz, Sweep = auto.
5. Mark Peak ,2.4GHz and 2.4835GHz and record the max. level.
6. Repeat above procedures until all frequency measured were complete.

### 9.3 Measurement Result

Refer to attach spectrum analyzer data chart.

### 9.4 Measurement Equipment Used:

EQUIPMENT TYPE	MFR	Model No.	Serial No.	LAST CAL.	Cal. Due.
Spectrum Analyzer	Advantest	R3182	110600647	11/16/2002	11/15/2003
Spectrum Analyzer	R&S	FSP30	1093.4495.30	07/23/2002	07/22/2003
low loss cable	Huber + Suhner	Sucoflex 104	N/A	N/A	N/A



### Out of Band Test Data CH-Low

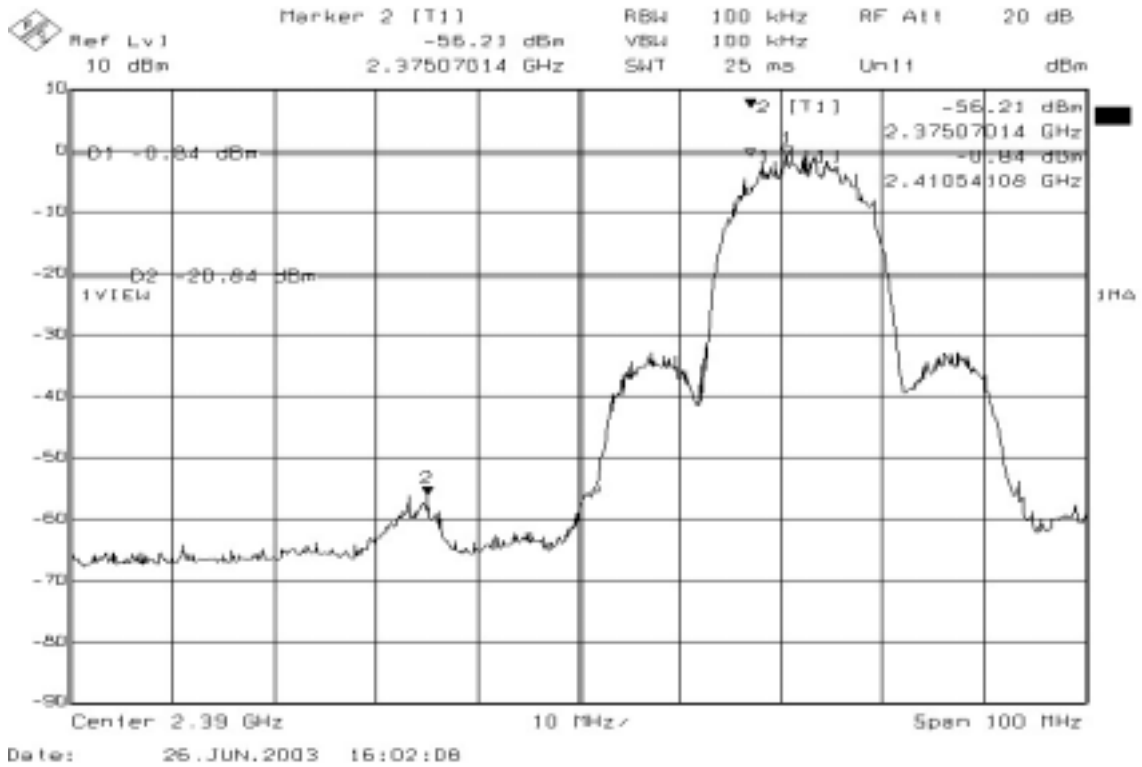

### Out of Band Test Data CH-High

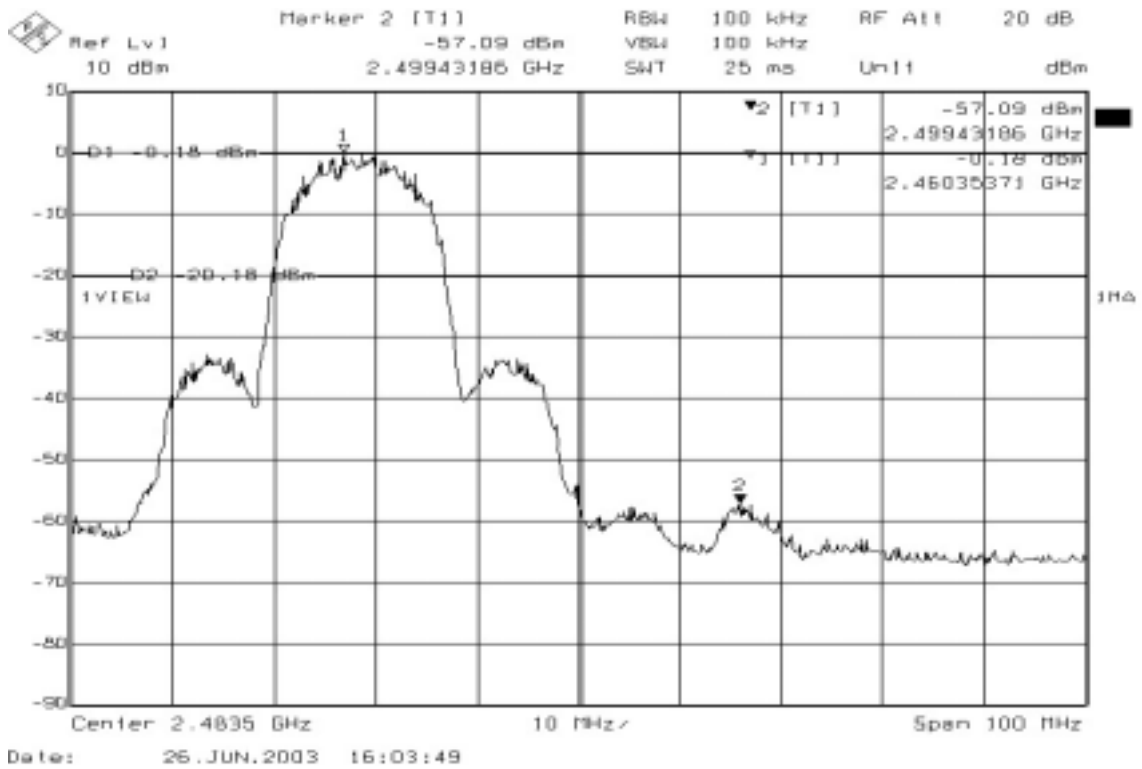



## 10. Peak Power Spectral Density

### 10.1 Standard Applicable

According to § 15.247(d), for direct sequence systems, the peak power spectral density conducted from the intentional radiator to the antenna shall not be greater than 8 dBm in any 3kHz band during any time interval of continuous transmission.

### 10.2 Measurement Procedure

1. Place the EUT on the table and set it in transmitting mode.
2. Remove the antenna from the EUT and then connect a low loss RF cable from the antenna port to the spectrum analyzer.
3. Set the spectrum analyzer as RBW = 3KHz, VBW = 3KHz, Span = 300KHz, Sweep=100s
4. Record the max. reading.
5. Repeat above procedures until all frequency measured were complete.

### 10.3 Measurement Result

CHANNE L	Reading dBm	Cable Loss dB	Density dBm	Limit dBm	Result
Low	-16.56	2.50	-14.06	8	PASS
Mid	-16.59	2.50	-14.09	8	PASS
High	-16.17	2.50	-13.67	8	PASS

### 10.4 Measurement Equipment Used:

EQUIPMENT TYPE	MFR	Model No.	Serial No.	LAST CAL.	Cal. Due.
Spectrum Analyzer	Advantest	R3182	110600647	11/16/2002	11/15/2003
Spectrum Analyzer	R&S	FSP30	1093.4495.30	07/23/2002	07/22/2003
low loss cable	Huber + Suhner	Sucoflex 104	N/A	N/A	N/A



### Power Density Test Data CH-Low

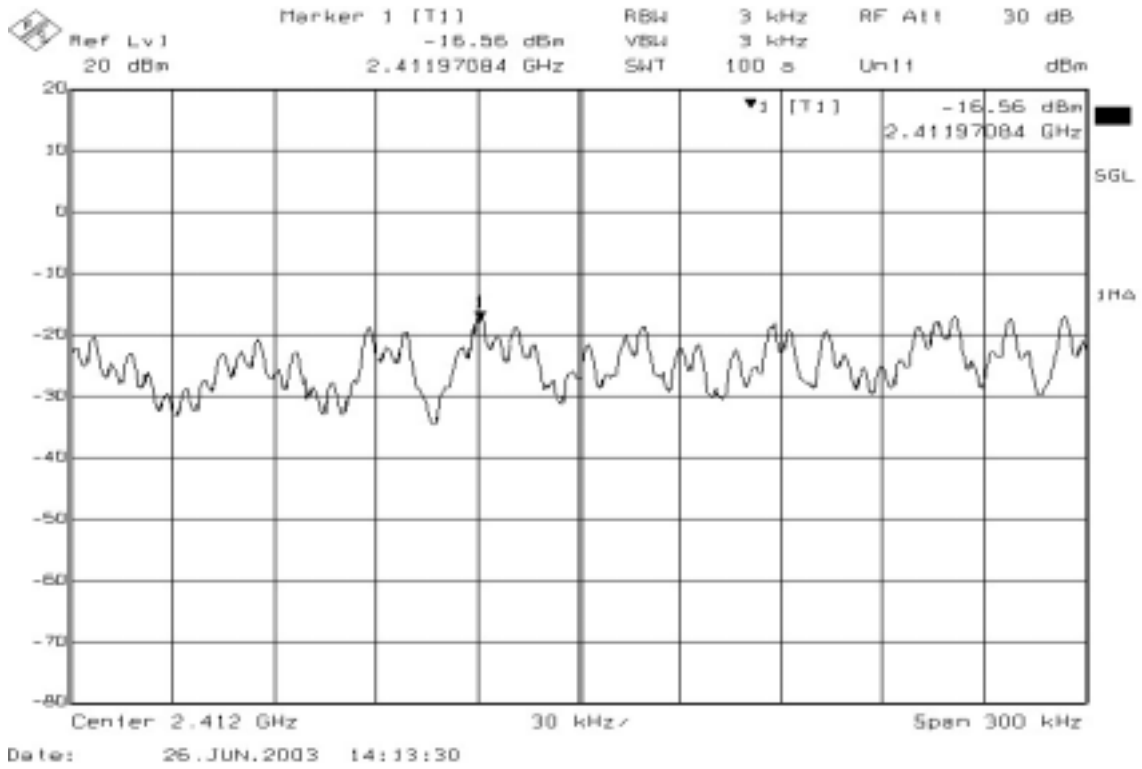

### Power Density Test Data CH-Mid

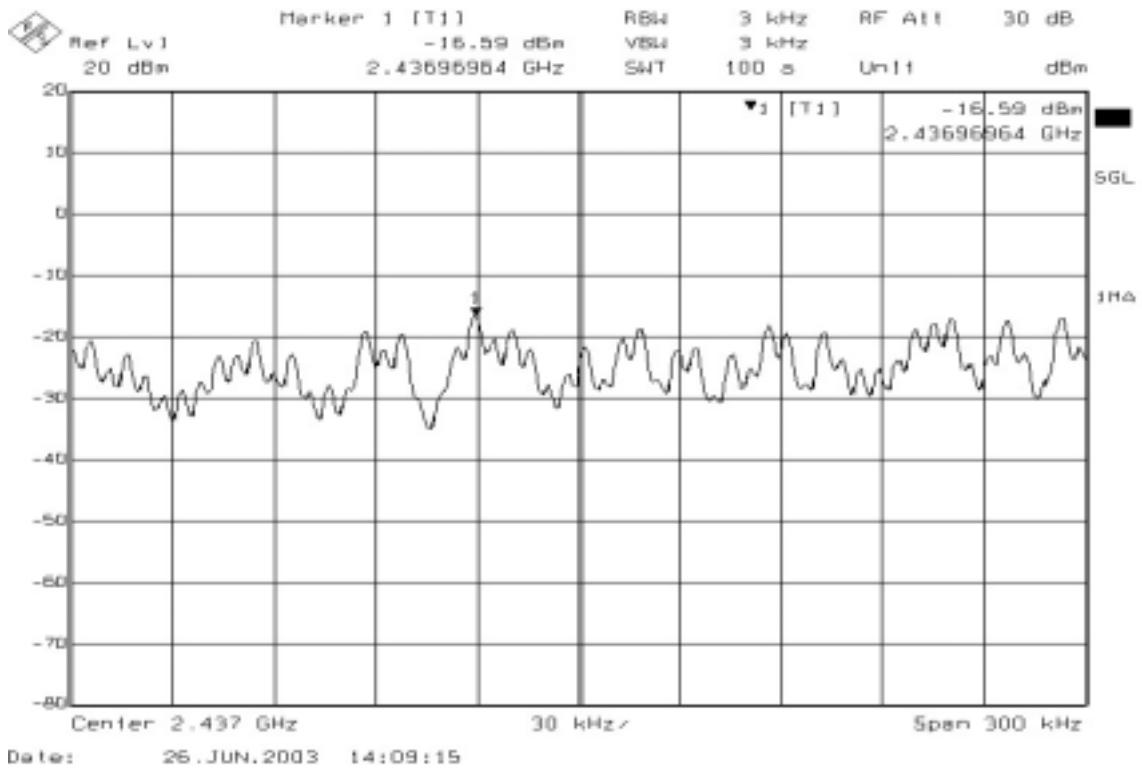



### Power Density Test Data CH-High

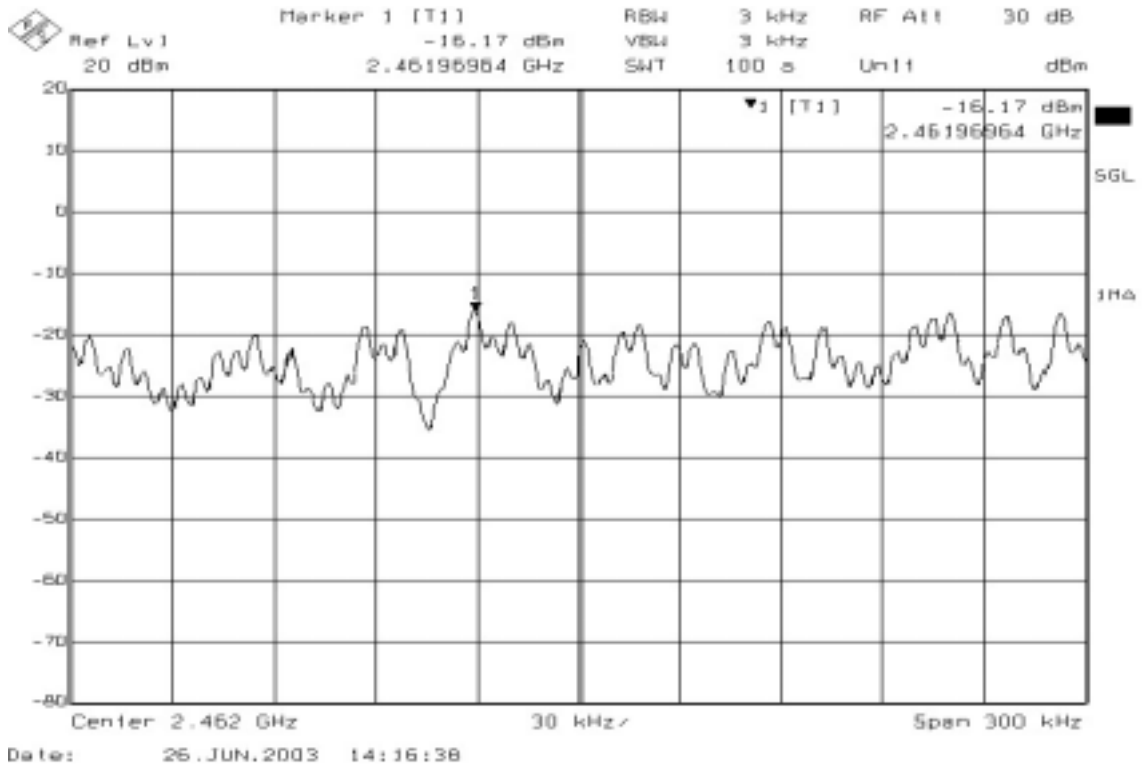



## 11. ANTENNA REQUIREMENT

### 11.1 Standard Applicable

For intentional device, according to § 15.203, an intentional radiator shall be designed to ensure that no antenna other than furnished by the responsible party shall be used with the device.

And according to § 15.247(4)(i), if transmitting antennas of directional gain greater than 6dBi are used the power shall be reduced by the amount in 1dB that the directional gain of the antenna exceeds 6 dBi.

### 11.2 Antenna Connected Construction

The directional gains of antenna used for transmitting is 1.196 dBi, the antenna is soldered onto the PCB board and equipped with no user-serviceable connector.

Please see Antenna Specification for details.





## 12. RF Exposure

### 12.1 Standard Applicable

According to § 15.247(b)(4) and § 1.1307(b)(1), systems operating under the provisions of this section shall be operated in a manner that ensure that the public is not exposed to radio frequency energy level in excess of the Commission’s guideline.

This device is classed as a Mobile Device.

According to § 1.1310 and § 2.1093 RF exposure is calculated.

#### Limits for Maximum Permissive Exposure (MPE)

Frequency Range (MHz)	Electric Field Strength (V/m)	Magnetic Field Strength (A/m)	Power Density (mW/cm <sup>2</sup> )	Averaging Time (minute)
Limits for General Population/Uncontrolled Exposure				
0.3-1.34	614	1.63	*(100)	30
1.34-30	824/f	2.19/f	*(180/f <sup>2</sup> )	30
30-300	27.5	0.073	0.2	30
300-1500	/	/	F/1500	30
1500-15000	/	/	1.0	30

F = frequency in MHz

\* = Plane-wave equipment power density

#### MPE Prediction

Not applicable.

MPE calculation is not applicable to address portable RF exposure requirement.