



SPORTON International Inc.

No. 52, Hwa Ya 1st Rd., Hwa Ya Technology Park, Kwei-Shan Hsiang, Tao Yuan Hsien, Taiwan, R.O.C.
Ph: 886-3-327-3456 / FAX: 886-3-327-0973 / www.sporton.com.tw

FCC RADIO TEST REPORT

Applicant's company	Broadcom Corporation
Applicant Address	190 Mathilda Place Sunnyvale CA 94086 U.S.A.
FCC ID	QDS-BRCM1085
Manufacturer's company	Broadcom Corporation
Manufacturer Address	190 Mathilda Place Sunnyvale CA 94086 U.S.A.

Product Name	Broadcom 802.11a/b/g/n/ac WLAN + Bluetooth PCI-E NGFF 2230 Card
Brand Name	Broadcom
Model Name	BCM94356Z
Part No.	BCM94356Z, BCM94356ZAE
Test Rule	47 CFR FCC Part 15 Subpart C § 15.247
Test Freq. Range	2402 ~ 2480MHz
Received Date	Jul. 31, 2014
Final Test Date	May 16, 2015
Submission Type	Class II Change

Statement

Test result included is only for the Bluetooth BR/EDR of the product.

The test result in this report refers exclusively to the presented test model / sample.

Without written approval of SPORTON International Inc., the test report shall not be reproduced except in full.

The measurements and test results shown in this test report were made in accordance with the procedures and found in compliance with the limit given in **ANSI C63.10-2009** and **47 CFR FCC Part 15 Subpart C**.

The test equipment used to perform the test is calibrated and traceable to NML/ROC.

Note: Using 1.5m table as an alternative was permitted by the FCC per TCBC conference call of Dec. 2, 2014.





Table of Contents

1. VERIFICATION OF COMPLIANCE	1
2. SUMMARY OF THE TEST RESULT	2
3. GENERAL INFORMATION	3
3.1. Product Details.....	3
3.2. Accessories.....	3
3.3. Table for Filed Antenna.....	4
3.4. Table for Carrier Frequencies	4
3.5. Table for Test Modes.....	5
3.6. Table for Testing Locations.....	5
3.7. Table for Class II Change and Multiple List.....	6
3.8. Table for Supporting Units	6
3.9. Table for Parameters of Test Software Setting	7
3.10. EUT Operation during Test	7
3.11. Duty Cycle.....	7
3.12. Maximum Conducted Output Power for original report	8
3.13. Test Configurations	9
4. TEST RESULT	11
4.1. Radiated Emissions Measurement	11
4.2. Emissions Measurement	24
4.3. Antenna Requirements	44
5. LIST OF MEASURING EQUIPMENTS	45
6. MEASUREMENT UNCERTAINTY	46
APPENDIX A. TEST PHOTOS	A1 ~ A7
APPENDIX B. RADIATED EMISSION CO-LOCATION REPORT	B1 ~ B5



History of This Test Report

REPORT NO.	VERSION	DESCRIPTION	ISSUED DATE
FR473142-05AC	Rev. 01	Initial issue of report	Jun. 04, 2015

1. VERIFICATION OF COMPLIANCE

Product Name : Broadcom 802.11 a/b/g/n/ac WLAN + Bluetooth PCI-E NGFF 2230 Card
Brand Name : Broadcom
Model Name : BCM94356Z
Part No. : BCM94356Z, BCM94356ZAE
Applicant : Broadcom Corporation
Test Rule Part(s) : 47 CFR FCC Part 15 Subpart C § 15.247

Sporton International as requested by the applicant to evaluate the EMC performance of the product sample received on Jul. 31, 2014 would like to declare that the tested sample has been evaluated and found to be in compliance with the tested rule parts. The data recorded as well as the test configuration specified is true and accurate for showing the sample's EMC nature.



Sam Chen

SPORTON INTERNATIONAL INC.

2. SUMMARY OF THE TEST RESULT

Applied Standard: 47 CFR FCC Part 15 Subpart C				
Part	Rule Section	Description of Test	Result	Under Limit
4.1	15.247(d)	Radiated Emissions	Complies	2.25 dB
4.2	15.247(d)	Band Edge Emissions	Complies	6.11 dB
4.3	15.203	Antenna Requirements	Complies	-

3. GENERAL INFORMATION

3.1. Product Details

Items	Description
Power Type	From host system
Modulation	FHSS (GFSK / $\pi/4$ -DQPSK / 8DPSK)
Data Rate (Mbps)	GFSK: 1 ; $\pi/4$ -DQPSK: 2 ; 8DPSK: 3
Frequency Range	2402 ~ 2480MHz
Channel Number	79
Maximum Conducted Peak Output Power	BR (GFSK) 1 Mbps: 12.59 dBm EDR ($\pi/4$ -DQPSK) 2 Mbps: 11.97 dBm EDR (8DPSK) 3 Mbps: 12.06 dBm
Maximum Conducted Average Output Power	BR (GFSK) 1 Mbps: 11.48 dBm EDR ($\pi/4$ -DQPSK) 2 Mbps: 7.96 dBm EDR (8DPSK) 3 Mbps: 8.01 dBm
Carrier Frequencies	Please refer to section 3.4
Antenna	Please refer to section 3.3
Note 1: Bluetooth BR uses a combination of GFSK (1Mbps).	
Note 2: Bluetooth EDR uses a combination of $\pi/4$ -DQPSK (2Mbps) and 8DPSK (3Mbps).	

3.2. Accessories

N/A

3.3. Table for Filed Antenna

Ant.	Brand Holder	Model No.	Antenna Type	Connector	Gain (dBi)				
					2.4G/ BT	5G B1	5G B2	5G B3	5G B4
1	INPAQ TECHNOLOGY CO., LTD.	DAM-I6-H-DB-800-10-17	Dipole antenna	SMA RP PLUG	1.29	1.94	1.94	-0.49	-0.93

Note:

For 2.4 GHz WLAN function (2TX/2RX):

Chain 1 and Chain 2 could transmit/receive simultaneously.

For Bluetooth function (1TX/1RX):

Only Chain 1 could transmit/receive simultaneously.

For 5 GHz WLAN function (2TX/2RX):

Chain 1 and Chain 2 could transmit/receive simultaneously.

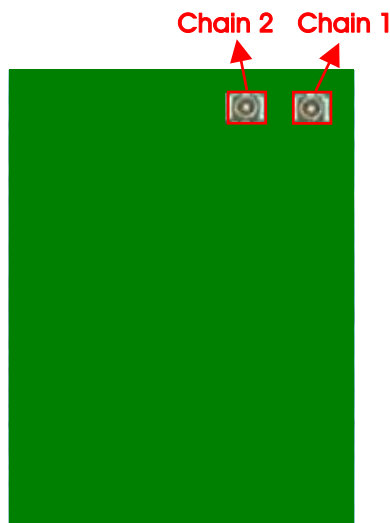

3.4. Table for Carrier Frequencies

Frequency Band	Channel No.	Frequency	Channel No.	Frequency
2400~2483.5MHz	0	2402 MHz	40	2442 MHz
	1	2403 MHz	:	:
	:	:	77	2479 MHz
	38	2440 MHz	78	2480 MHz
	39	2441 MHz	-	-

3.5. Table for Test Modes

Preliminary tests were performed in different data rate to find the worst radiated emission. The data rate shown in the table below is the worst-case rate with respect to the specific test item. Investigation has been done on all the possible configurations for searching the worst cases. The following table is a list of the test modes shown in this test report.

Test Items	Mode	Data Rate	Channel	Chain
Radiated Emissions Below 1GHz	Normal Link	-	-	-
Radiated Emissions Above 1GHz	BR (GFSK)	1 Mbps	0/39/78	1
	EDR (8DPSK)	3 Mbps	0/39/78	1
Band Edge Emissions	BR (GFSK)	1 Mbps	0/39/78	1
	EDR (8DPSK)	3 Mbps	0/39/78	1

The following test modes were performed for all tests:

For Radiated Emission test below 1GHz:

According to original test report, the Radiated Emissions 9kHz~1GHz test was perform at its 3-axis (X-axis, Y-axis and Z-axis) and the worst-case was found at X-axis. Thus this test will follow this test mode.

Mode 1. 2.4GHz WLAN function + Bluetooth function

Mode 2. 5GHz WLAN function + Bluetooth function

Mode 1 is the worst case, so it was selected to record in this test report.

For Radiated Emission test above 1GHz:

According to original test report, the Radiated Emissions above 1GHz test was perform at its 3-axis (X-axis, Y-axis and Z-axis) and the worst-case was found at X-axis. Thus this test will follow this test mode.

Mode 1. CTX-EUT

For Co-location test:

Mode 1. 2.4GHz WLAN function + Bluetooth function

Mode 2. 5GHz WLAN function + Bluetooth function

3.6. Table for Testing Locations

Test Site Location					
Address:	No.8, Lane 724, Bo-ai St., Jhubei City, Hsinchu County 302, Taiwan, R.O.C.				
TEL:	886-3-656-9065				
FAX:	886-3-656-9085				
Test Site No.	Site Category	Location	FCC Reg. No.	IC File No.	VCCI Reg. No
03CH01-CB	SAC	Hsin Chu	262045	IC 4086D	-

Open Area Test Site (OATS); Semi Anechoic Chamber (SAC).

3.7. Table for Class II Change and Multiple List

The EUT has two part numbers which are identical to each other in all aspects except for the following table:

Model No.	Part No.	Description
BCM94356Z	BCM94356Z	The base pin between these two models is different.
	BCM94356ZAE	

From the above models, part number: BCM94356Z was selected as representative model for the test and its data was recorded in this report.

This product is an extension of original one reported under Sporton project number: FR473142AC

Below is the table for the change of the product with respect to the original one.

Modifications	Performance Checking
Adding a dipole antenna	1. Radiated Emissions Measurement 2. Emissions Measurement 3. Radiated Emission Co-location

Note: The above test items will be based on original output power to re-test.

3.8. Table for Supporting Units

For Test Site No: 03CH01-CB

For Radiated Emission test below 1GHz:

Support Unit	Brand	Model	FCC ID
Notebook*2	DELL	E4300	DoC
Wireless ac AP	Netgear	R6300V2	PY313200227
Mouse	Logitech	M-U0026	DoC
Earphone	SHYARO CHI	MIC-04	N/A
Test Fixture*2	Broadcom	BCM9MC2EC_1	N/A
Broadcom 802.11a/b/g/n/ac WLAN + Bluetooth PCI-E NGFF 2230 Card (Device)	Broadcom	BCM94356Z	QDS-BRCM1085

For Radiated Emission test above 1GHz:

Support Unit	Brand	Model	FCC ID
Notebook	DELL	E4300	DoC
Test Fixture	Broadcom	BCM9MC2EC_1	N/A

3.9. Table for Parameters of Test Software Setting

During testing, Channel and Power Controlling Software provided by the customer was used to control the operating channel as well as the output power level. The RF output power selection is for the setting of RF output power expected by the customer and is going to be fixed on the firmware of the final end product.

Power Parameters of Bluetooth

For BR (GFSK) 1 Mbps:

Test Software Version	Broadcom BlueTool V1.8.7.9		
Frequency	2402 MHz	2441 MHz	2480 MHz
Power Parameters	0	0	0

For EDR ($\pi/4$ -DQPSK) 2 Mbps:

Test Software Version	Broadcom BlueTool V1.8.7.9		
Frequency	2402 MHz	2441 MHz	2480 MHz
Power Parameters	0	0	0

For EDR (8DPSK) 3 Mbps:

Test Software Version	Broadcom BlueTool V1.8.7.9		
Frequency	2402 MHz	2441 MHz	2480 MHz
Power Parameters	0	0	0

3.10. EUT Operation during Test

The EUT was programmed to be in continuously transmitting mode.

3.11. Duty Cycle

Mode	On Time (ms)	On+Off Time (ms)	Duty Cycle (%)	Duty Factor (dB)	1/T Minimum VBW (kHz)
BR (GFSK)	2.900	3.669	79.04	1.02	0.34
EDR ($\pi/4$ -DQPSK)	2.900	3.685	78.70	1.04	0.34
EDR (8DPSK)	2.900	3.717	78.02	1.08	0.34

3.12. Maximum Conducted Output Power for original report

For BR (GFSK) 1 Mbps:

Channel	Frequency	Conducted Peak Power (dBm)	Conducted Average Power (dBm)	Max. Limit (dBm)	Result
0	2402 MHz	11.34	10.01	21.00	Complies
39	2441 MHz	12.42	11.26	21.00	Complies
78	2480 MHz	12.59	11.48	21.00	Complies

For EDR ($\pi/4$ -DQPSK) 2 Mbps:

Channel	Frequency	Conducted Peak Power (dBm)	Conducted Average Power (dBm)	Max. Limit (dBm)	Result
0	2402 MHz	10.62	6.71	21.00	Complies
39	2441 MHz	11.54	7.75	21.00	Complies
78	2480 MHz	11.97	7.96	21.00	Complies

For EDR (8DPSK) 3 Mbps:

Channel	Frequency	Conducted Peak Power (dBm)	Conducted Average Power (dBm)	Max. Limit (dBm)	Result
0	2402 MHz	10.61	6.74	21.00	Complies
39	2441 MHz	11.69	7.78	21.00	Complies
78	2480 MHz	12.06	8.01	21.00	Complies

3.13. Test Configurations

3.13.1. Radiation Emissions Test Configuration

Test Configuration: 30MHz~1GHz

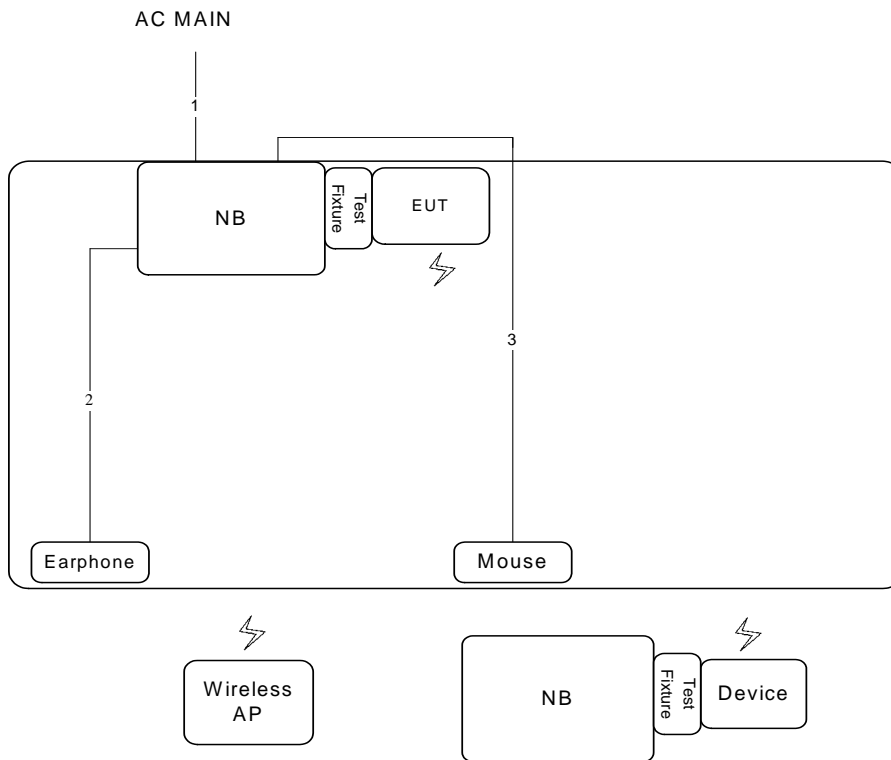

Item	Connection	Shielded	Length
1	Power cable	No	2.6m
2	Audio cable	No	1.1m
3	USB cable	Yes	1.8m

Test Configuration: above 1GHz

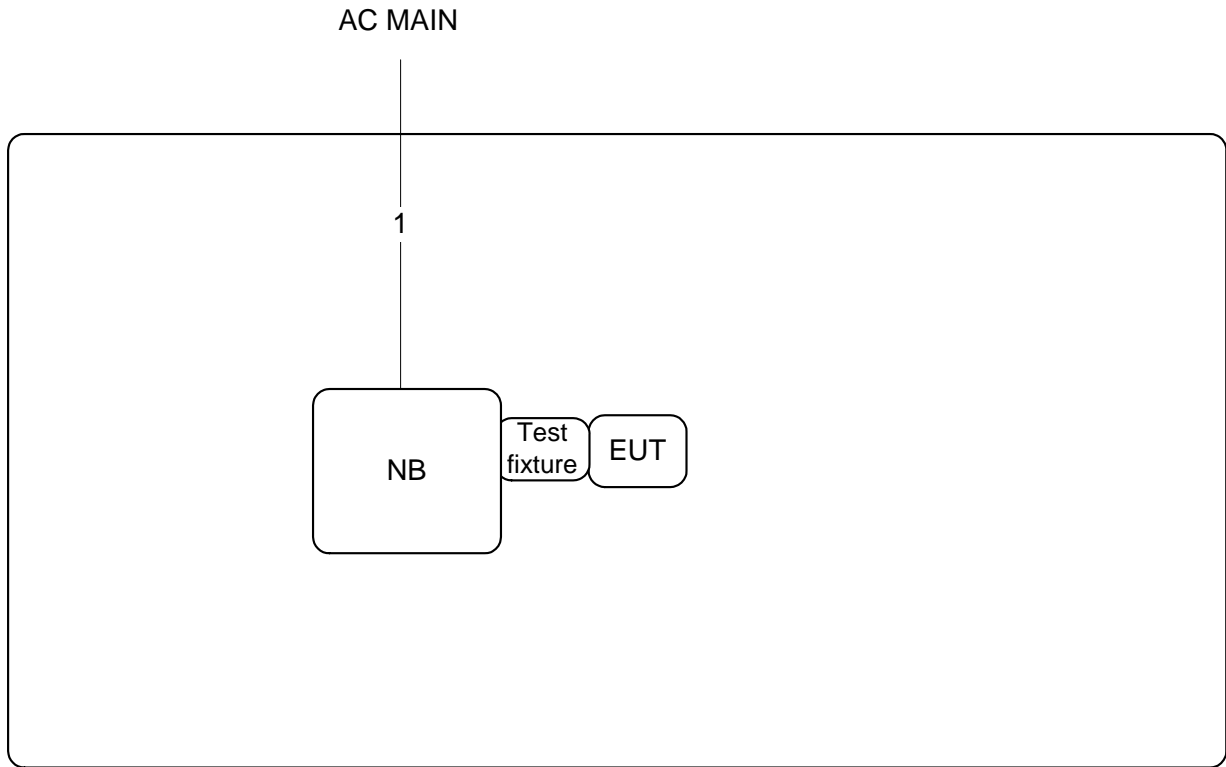

Item	Connection	Shielded	Length
1	Power cable	No	1.8m

4. TEST RESULT

4.1. Radiated Emissions Measurement

4.1.1. Limit

20dBc in any 100 kHz bandwidth outside the operating frequency band. In case the emission fall within the restricted band specified on 15.205(a), then the 15.209(a) limit in the table below has to be followed.

Frequencies (MHz)	Field Strength (micovolts/meter)	Measurement Distance (meters)
0.009~0.490	2400/F(kHz)	300
0.490~1.705	24000/F(kHz)	30
1.705~30.0	30	30
30~88	100	3
88~216	150	3
216~960	200	3
Above 960	500	3

4.1.2. Measuring Instruments and Setting

Please refer to section 5 of equipments list in this report. The following table is the setting of spectrum analyzer and receiver.

Spectrum Parameter	Setting
Attenuation	Auto
Start Frequency	1000 MHz
Stop Frequency	10th carrier harmonic
RBW / VBW (Emission in restricted band)	1 MHz / 3MHz for Peak, 1 MHz / 1/T for Average
RBW / VBW (Emission in non-restricted band)	100kHz, 300kHz for peak

Receiver Parameter	Setting
Attenuation	Auto
Start ~ Stop Frequency	9kHz~150kHz, RBW 200Hz for QP
Start ~ Stop Frequency	150kHz~30MHz, RBW 9kHz for QP
Start ~ Stop Frequency	30MHz~1000MHz, RBW 120kHz for QP

4.1.3. Test Procedures

1. Configure the EUT according to ANSI C63.10. The EUT was placed on the top of the turntable 1.5 meter above ground. The phase center of the receiving antenna mounted on the top of a height-variable antenna tower was placed 1m & 3m far away from the turntable.
2. Power on the EUT and all the supporting units. The turntable was rotated by 360 degrees to determine the position of the highest radiation.
3. The height of the broadband receiving antenna was varied between one meter and four meters above ground to find the maximum emissions field strength of both horizontal and vertical polarization.
4. For each suspected emissions, the antenna tower was scan (from 1 M to 4 M) and then the turntable was rotated (from 0 degree to 360 degrees) to find the maximum reading.
5. Set the test-receiver system to Peak or CISPR quasi-peak Detect Function with specified bandwidth under Maximum Hold Mode.
6. For emissions above 1GHz, use 1MHz VBW and 3MHz RBW for peak reading. Then 1MHz RBW and 1/T VBW for average reading in spectrum analyzer.
7. When the radiated emissions limits are expressed in terms of the average value of the emissions, and pulsed operation is employed, the measurement field strength shall be determined by averaging over one complete pulse train, including blanking intervals, as long as the pulse train does not exceed 0.1 seconds. As an alternative (provided the transmitter operates for longer than 0.1 seconds) or in cases where the pulse train exceeds 0.1 seconds, the measured field strength shall be determined from the average absolute voltage during a 0.1 second interval during which the field strength is at its maximum value.
8. If the emissions level of the EUT in peak mode was 3 dB lower than the average limit specified, then testing will be stopped and peak values of EUT will be reported, otherwise, the emissions which do not have 3 dB margin will be repeated one by one using the quasi-peak method for below 1GHz.
9. For testing above 1GHz, the emissions level of the EUT in peak mode was lower than average limit (that means the emissions level in peak mode also complies with the limit in average mode), then testing will be stopped and peak values of EUT will be reported, otherwise, the emissions will be measured in average mode again and reported.
10. In case the emission is lower than 30MHz, loop antenna has to be used for measurement and the recorded data should be QP measured by receiver. High – Low scan is not required in this case.

4.1.4. Test Setup Layout

For Radiated Emissions: 9kHz ~30MHz

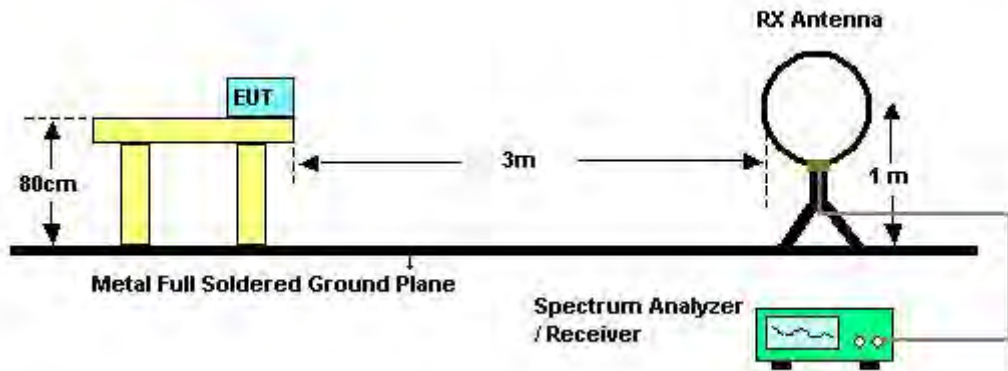

For Radiated Emissions: 30MHz~1GHz

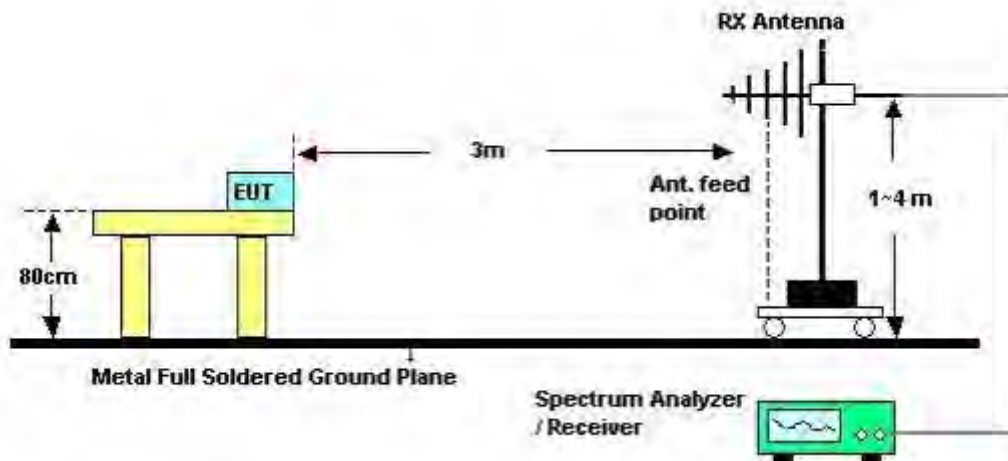

For Radiated Emissions: Above 1GHz

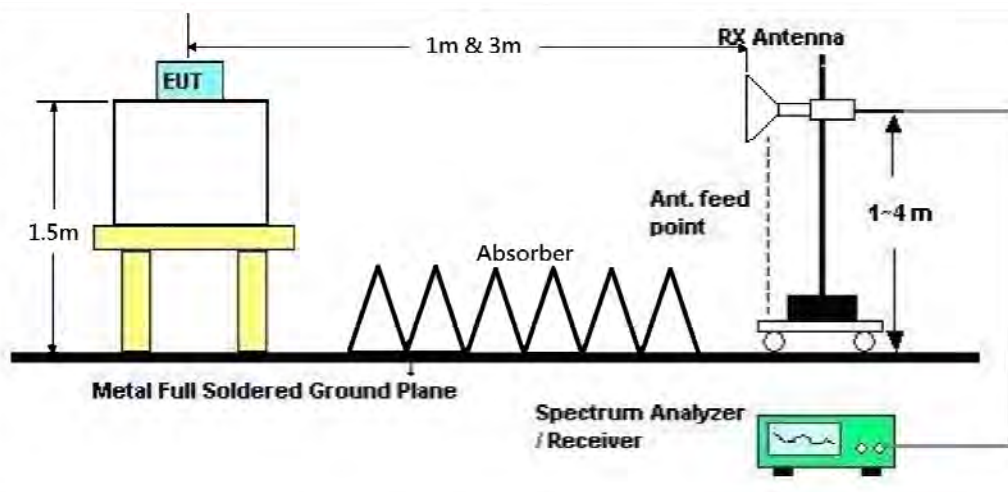

4.1.5. Test Deviation

There is no deviation with the original standard.

4.1.6. EUT Operation during Test

The EUT was programmed to be in continuously transmitting mode.

4.1.7. Results of Radiated Emissions (9kHz~30MHz)

Temperature	26°C	Humidity	51%
Test Engineer	Mars Lin	Test Date	May 14, 2015
Configurations	Normal Link	Test Mode	Mode 1

Freq. (MHz)	Level (dBuV)	Over Limit (dB)	Limit Line (dBuV)	Remark
-	-	-	-	See Note

Note:

The amplitude of spurious emissions which are attenuated by more than 20dB below the permissible value has no need to be reported.

Distance extrapolation factor = $40 \log(\text{specific distance} / \text{test distance})$ (dB);

Limit line = specific limits (dBuV) + distance extrapolation factor.

4.1.8. Results of Radiated Emissions (30MHz~1GHz)

Temperature	26°C	Humidity	51%
Test Engineer	Mars Lin	Configurations	Normal Link
Test Mode	Mode 1		

Horizontal

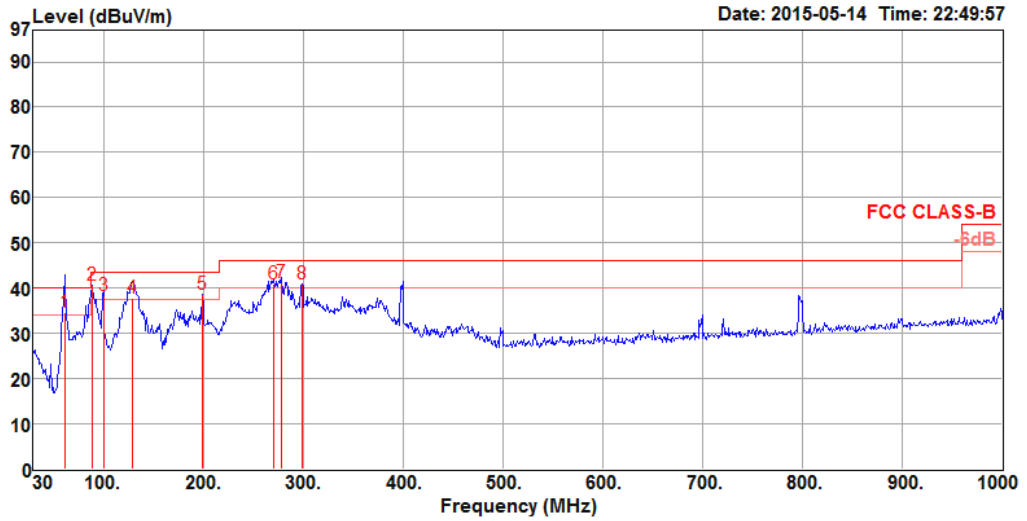

	Freq	Level	Limit	Over	Read	Cable	Preamp	Antenna		T/Pos	A/Pos	Remark
	MHz	dBuV/m	dBuV/m	dB	dBuV	dB	dB	dB/m	Pol/Phase	deg	cm	
1	61.04	34.69	40.00	-5.31	59.60	0.79	32.50	6.80	HORIZONTAL	46	300	QP
2	88.20	40.50	43.50	-3.00	63.06	0.94	32.43	8.93	HORIZONTAL	195	400	Peak
3	99.84	38.31	43.50	-5.19	58.73	0.98	32.47	11.07	HORIZONTAL	202	400	Peak
4	128.94	37.67	43.50	-5.83	56.34	1.15	32.43	12.61	HORIZONTAL	237	150	QP
5	198.78	38.50	43.50	-5.00	59.20	1.39	32.29	10.20	HORIZONTAL	178	150	Peak
6	270.56	40.80	46.00	-5.20	57.92	1.63	32.44	13.69	HORIZONTAL	137	125	Peak
7	278.32	41.22	46.00	-4.78	58.44	1.65	32.40	13.53	HORIZONTAL	276	125	Peak
8	298.69	40.97	46.00	-5.03	57.69	1.71	32.30	13.87	HORIZONTAL	336	125	Peak

Vertical

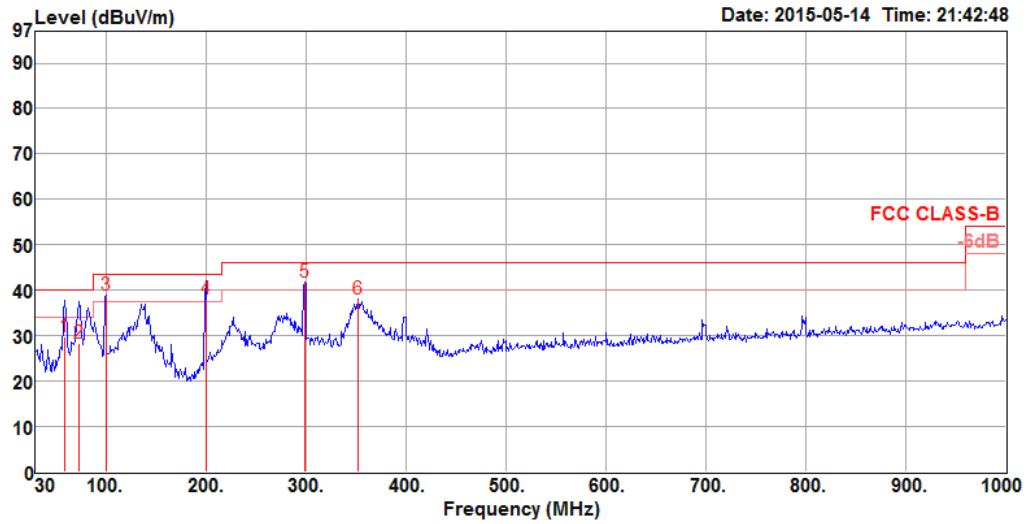

	Freq	Level	Limit	Over	Read	Cable	Preamp	Antenna		T/Pos	A/Pos	Remark
	MHz	dBuV/m	dBuV/m	dB	dBuV	dB	dB	dB/m	Pol/Phase	deg	cm	
1	59.10	29.91	40.00	-10.09	54.61	0.78	32.50	7.02	VERTICAL	124	400	QP
2	73.65	28.40	40.00	-11.60	52.85	0.87	32.41	7.09	VERTICAL	116	100	QP
3	99.84	38.80	43.50	-4.70	59.19	0.98	32.47	11.10	VERTICAL	92	300	Peak
4	199.75	38.05	43.50	-5.45	58.65	1.39	32.29	10.30	VERTICAL	69	200	Peak
5	298.69	41.88	46.00	-4.12	58.59	1.71	32.30	13.88	VERTICAL	192	150	Peak
6	352.04	38.06	46.00	-7.94	53.20	1.87	32.36	15.35	VERTICAL	4	200	Peak

Note:

The amplitude of spurious emissions which are attenuated by more than 20 dB below the permissible value has no need to be reported.

Emission level (dBuV/m) = 20 log Emission level (uV/m).

Corrected Reading: Antenna Factor + Cable Loss + Read Level - Preamp Factor = Level.

4.1.9. Results for Radiated Emissions (1GHz~10th Harmonic)

Temperature	26°C	Humidity	51%
Test Engineer	Mars Lin	Configurations	BR (GFSK) / Channel 0
Test Date	May 13, 2015		

Horizontal

	Freq	Level	Limit Line	Over Limit	Read Level	CableAntenna Loss	Antenna Factor	Preamp Factor	Remark	A/Pos	T/Pos	Pol/Phase
	MHz	dBuV/m	dBuV/m	dB	dBuV	dB	dB/m	dB		cm	deg	
1	4803.88	48.00	54.00	-6.00	44.33	5.85	32.78	34.96	Average	175	345	HORIZONTAL
2	4804.09	51.60	74.00	-22.40	47.93	5.85	32.78	34.96	Peak	175	345	HORIZONTAL

Vertical

	Freq	Level	Limit Line	Over Limit	Read Level	CableAntenna Loss	Antenna Factor	Preamp Factor	Remark	A/Pos	T/Pos	Pol/Phase
	MHz	dBuV/m	dBuV/m	dB	dBuV	dB	dB/m	dB		cm	deg	
1	4803.75	53.67	74.00	-20.33	50.00	5.85	32.78	34.96	Peak	132	100	VERTICAL
2	4803.96	51.48	54.00	-2.52	47.81	5.85	32.78	34.96	Average	132	100	VERTICAL



Temperature	26°C	Humidity	51%
Test Engineer	Mars Lin	Configurations	BR (GFSK) / Channel 39
Test Date	May 13, 2015		

Horizontal

	Freq	Level	Limit Line	Over Limit	Read Level	CableAntenna Loss	Antenna Factor	Preamp Factor	Remark	A/Pos	T/Pos	Pol/Phase
	MHz	dBuV/m	dBuV/m	dB	dBuV	dB	dB/m	dB		cm	deg	
1	4881.84	44.67	54.00	-9.33	40.78	5.92	32.93	34.96	Average	155	301	HORIZONTAL
2	4882.27	52.07	74.00	-21.93	48.18	5.92	32.93	34.96	Peak	155	301	HORIZONTAL

Vertical

	Freq	Level	Limit Line	Over Limit	Read Level	CableAntenna Loss	Antenna Factor	Preamp Factor	Remark	A/Pos	T/Pos	Pol/Phase
	MHz	dBuV/m	dBuV/m	dB	dBuV	dB	dB/m	dB		cm	deg	
1	4881.70	54.97	74.00	-19.03	51.08	5.92	32.93	34.96	Peak	163	279	VERTICAL
2	4881.81	51.75	54.00	-2.25	47.86	5.92	32.93	34.96	Average	163	279	VERTICAL



Temperature	26°C	Humidity	51%
Test Engineer	Mars Lin	Configurations	BR (GFSK) / Channel 78
Test Date	May 13, 2015		

Horizontal

	Freq	Level	Limit Line	Over Limit	Read Level	CableAntenna Loss	Antenna Factor	Preamp Factor	Remark	A/Pos	T/Pos	Pol/Phase
	MHz	dBuV/m	dBuV/m	dB	dBuV	dB	dB/m	dB		cm	deg	
1	4959.66	48.66	74.00	-25.34	44.49	6.00	33.12	34.95	Peak	165	341	HORIZONTAL
2	4959.84	41.39	54.00	-12.61	37.22	6.00	33.12	34.95	Average	165	341	HORIZONTAL

Vertical

	Freq	Level	Limit Line	Over Limit	Read Level	CableAntenna Loss	Antenna Factor	Preamp Factor	Remark	A/Pos	T/Pos	Pol/Phase
	MHz	dBuV/m	dBuV/m	dB	dBuV	dB	dB/m	dB		cm	deg	
1	4959.53	55.25	74.00	-18.75	51.08	6.00	33.12	34.95	Peak	192	121	VERTICAL
2	4959.85	51.37	54.00	-2.63	47.20	6.00	33.12	34.95	Average	192	121	VERTICAL

Note:

The amplitude of spurious emissions which are attenuated by more than 20dB below the permissible value has no need to be reported.

Emission level (dBuV/m) = 20 log Emission level (uV/m).

Corrected Reading: Antenna Factor + Cable Loss + Read Level - Preamp Factor = Level.



Temperature	26°C	Humidity	51%
Test Engineer	Mars Lin	Configurations	EDR (8DPSK) / Channel 0
Test Date	May 13, 2015		

Horizontal

	Freq	Level	Limit Line	Over Limit	Read Level	CableAntenna Loss	Antenna Factor	Preamp Factor	Remark	A/Pos	T/Pos	Pol/Phase
	MHz	dBuV/m	dBuV/m	dB	dBuV	dB	dB/m	dB		cm	deg	
1	4803.76	49.34	74.00	-24.66	45.67	5.85	32.78	34.96	Peak	184	252	HORIZONTAL
2	4805.81	42.74	54.00	-11.26	39.07	5.85	32.78	34.96	Average	184	252	HORIZONTAL

Vertical

	Freq	Level	Limit Line	Over Limit	Read Level	CableAntenna Loss	Antenna Factor	Preamp Factor	Remark	A/Pos	T/Pos	Pol/Phase
	MHz	dBuV/m	dBuV/m	dB	dBuV	dB	dB/m	dB		cm	deg	
1	4801.56	52.47	74.00	-21.53	48.80	5.85	32.78	34.96	Peak	220	121	VERTICAL
2	4803.91	47.09	54.00	-6.91	43.42	5.85	32.78	34.96	Average	220	121	VERTICAL



Temperature	26°C	Humidity	51%
Test Engineer	Mars Lin	Configurations	EDR (8DPSK) / Channel 39
Test Date	May 13, 2015		

Horizontal

	Freq	Level	Limit Line	Over Limit	Read Level	CableAntenna Loss	Antenna Factor	Preamp Factor	Remark	A/Pos	T/Pos	Pol/Phase
	MHz	dBuV/m	dBuV/m	dB	dBuV	dB	dB/m	dB		cm	deg	
1	4880.52	49.65	74.00	-24.35	45.76	5.92	32.93	34.96	Peak	165	222	HORIZONTAL
2	4881.91	43.67	54.00	-10.33	39.78	5.92	32.93	34.96	Average	165	222	HORIZONTAL

Vertical

	Freq	Level	Limit Line	Over Limit	Read Level	CableAntenna Loss	Antenna Factor	Preamp Factor	Remark	A/Pos	T/Pos	Pol/Phase
	MHz	dBuV/m	dBuV/m	dB	dBuV	dB	dB/m	dB		cm	deg	
1	4881.70	51.57	74.00	-22.43	47.68	5.92	32.93	34.96	Peak	134	57	VERTICAL
2	4881.87	46.58	54.00	-7.42	42.69	5.92	32.93	34.96	Average	134	57	VERTICAL

Temperature	26°C	Humidity	51%
Test Engineer	Mars Lin	Configurations	EDR (8DPSK) / Channel 78
Test Date	May 13, 2015		

Horizontal

	Freq	Level	Limit Line	Over Limit	Read Level	CableAntenna Loss	Antenna Factor	Preamp Factor	Remark	A/Pos	T/Pos	Pol/Phase
	MHz	dBuV/m	dBuV/m	dB	dBuV	dB	dB/m	dB		cm	deg	
1	4959.63	51.46	74.00	-22.54	47.29	6.00	33.12	34.95	Peak	162	147	HORIZONTAL
2	4959.85	42.20	54.00	-11.80	38.03	6.00	33.12	34.95	Average	162	147	HORIZONTAL

Vertical

	Freq	Level	Limit Line	Over Limit	Read Level	CableAntenna Loss	Antenna Factor	Preamp Factor	Remark	A/Pos	T/Pos	Pol/Phase
	MHz	dBuV/m	dBuV/m	dB	dBuV	dB	dB/m	dB		cm	deg	
1	4959.62	53.95	74.00	-20.05	49.78	6.00	33.12	34.95	Peak	176	273	VERTICAL
2	4959.77	45.98	54.00	-8.02	41.81	6.00	33.12	34.95	Average	176	273	VERTICAL

Note:

The amplitude of spurious emissions which are attenuated by more than 20dB below the permissible value has no need to be reported.

Emission level (dBuV/m) = 20 log Emission level (uV/m).

Corrected Reading: Antenna Factor + Cable Loss + Read Level - Preamp Factor = Level.

4.2. Emissions Measurement

4.2.1. Limit

20dBc in any 100 kHz bandwidth outside the operating frequency band. In case the emission fall within the restricted band specified on 15.205(a), then the 15.209(a) limit in the table below has to be followed.

Frequencies (MHz)	Field Strength (micovolts/meter)	Measurement Distance (meters)
0.009~0.490	2400/F(kHz)	300
0.490~1.705	24000/F(kHz)	30
1.705~30.0	30	30
30~88	100	3
88~216	150	3
216~960	200	3
Above 960	500	3

4.2.2. Measuring Instruments and Setting

Please refer to section 5 of equipments list in this report. The following table is the setting of the spectrum analyzer.

Spectrum Parameter	Setting
Attenuation	Auto
Span Frequency	100 MHz
RBW / VBW (Emission in restricted band)	1MHz / 3MHz for Peak, 1MHz / 1/T for Average
RBW / VBW (20dBc in any 100 kHz bandwidth emission)	100 kHz / 100 kHz for Peak

4.2.3. Test Procedures

For Radiated band edges Measurement:

- The test procedure is the same as section 4.1.3, only the frequency range investigated is limited to 100MHz around band edges.

For Radiated Out of Band Emission Measurement:

- The test procedure is follow 15.247(d).
Only worst data of each operating mode is presented

4.2.4. Test Setup Layout

For Radiated band edges Measurement:

This test setup layout is the same as that shown in section 4.1.4.

For Radiated Out of Band Emission Measurement:

This test setup layout is the same as that shown in section 4.1.4.

4.2.5. Test Deviation

There is no deviation with the original standard.

4.2.6. EUT Operation during Test

The EUT was programmed to be in continuously transmitting mode.

4.2.7. Test Result of Band Edge and Fundamental Emissions

Temperature	26°C	Humidity	51%
Test Engineer	Mars Lin	Configurations	BR (GFSK) / Channel 0, 39, 78
Test Date	May 13, 2015		

Channel 0

	Freq	Level	Limit	Over	Read	CableAntenna	Preamp	Remark	A/Pos	T/Pos	Pol/Phase
	MHz	dBuV/m	dBuV/m	dB	dBuV	dB	dB/m	dB	cm	deg	
1	2390.00	47.21	54.00	-6.79	14.28	4.09	28.84	0.00 Average	175	150	VERTICAL
2	2390.00	59.00	74.00	-15.00	26.07	4.09	28.84	0.00 Peak	175	150	VERTICAL
3	2402.00	103.45			70.52	4.09	28.84	0.00 Average	175	150	VERTICAL
4	2402.14	104.76			71.83	4.09	28.84	0.00 Peak	175	150	VERTICAL

Item 3, 4 are the fundamental frequency at 2402 MHz.

Channel 39

	Freq	Level	Limit	Over	Read	CableAntenna	Preamp	Remark	A/Pos	T/Pos	Pol/Phase
	MHz	dBuV/m	dBuV/m	dB	dBuV	dB	dB/m	dB	cm	deg	
1	2390.00	47.22	54.00	-6.78	14.29	4.09	28.84	0.00 Average	153	353	VERTICAL
2	2390.00	59.90	74.00	-14.10	26.97	4.09	28.84	0.00 Peak	153	353	VERTICAL
3	2441.00	101.42			68.42	4.13	28.87	0.00 Average	153	353	VERTICAL
4	2441.00	104.09			71.09	4.13	28.87	0.00 Peak	153	353	VERTICAL
5	2483.50	47.89	54.00	-6.11	14.84	4.16	28.89	0.00 Average	153	353	VERTICAL
6	2483.50	59.35	74.00	-14.65	26.30	4.16	28.89	0.00 Peak	153	353	VERTICAL

Item 3, 4 are the fundamental frequency at 2441 MHz.

Channel 78

	Freq	Level	Limit	Over	Read	CableAntenna	Preamp	Remark	A/Pos	T/Pos	Pol/Phase
	MHz	dBuV/m	dBuV/m	dB	dBuV	dB	dB/m	dB	cm	deg	
1	2479.86	104.60			71.55	4.16	28.89	0.00 Average	168	220	VERTICAL
2	2479.86	105.87			72.82	4.16	28.89	0.00 Peak	168	220	VERTICAL
3	2483.50	47.62	54.00	-6.38	14.57	4.16	28.89	0.00 Average	168	220	VERTICAL
4	2485.14	60.41	74.00	-13.59	27.36	4.16	28.89	0.00 Peak	168	220	VERTICAL

Item 1, 2 are the fundamental frequency at 2480 MHz.

Note: Both antenna polarizations have been tested and only the worst case was recorded in test report.

Note:

Emission level (dBuV/m) = 20 log Emission level (uV/m).

Corrected Reading: Antenna Factor + Cable Loss + Read Level - Preamp Factor = Level.

Temperature	26°C	Humidity	51%
Test Engineer	Mars Lin	Configurations	EDR (8DPSK) / Channel 0, 39, 78
Test Date	May 13, 2015		

Channel 0

	Freq	Level	Limit Line	Over Limit	Read Level	CableAntenna Loss	Antenna Factor	Preamp Factor	Remark	A/Pos	T/Pos	Pol/Phase
	MHz	dBuV/m	dBuV/m	dB	dBuV	dB	dB/m	dB		cm	deg	
1	2374.80	60.75	74.00	-13.25	27.84	4.08	28.83	0.00	Peak	201	174	VERTICAL
2	2390.00	47.08	54.00	-6.92	14.15	4.09	28.84	0.00	Average	201	174	VERTICAL
3	2402.00	98.38			65.45	4.09	28.84	0.00	Average	201	174	VERTICAL
4	2402.14	101.63			68.70	4.09	28.84	0.00	Peak	201	174	VERTICAL

Item 3, 4 are the fundamental frequency at 2402 MHz.

Channel 39

	Freq	Level	Limit Line	Over Limit	Read Level	CableAntenna Loss	Antenna Factor	Preamp Factor	Remark	A/Pos	T/Pos	Pol/Phase
	MHz	dBuV/m	dBuV/m	dB	dBuV	dB	dB/m	dB		cm	deg	
1	2372.92	59.59	74.00	-14.41	26.68	4.08	28.83	0.00	Peak	188	143	VERTICAL
2	2390.00	47.09	54.00	-6.91	14.16	4.09	28.84	0.00	Average	188	143	VERTICAL
3	2440.71	99.55			66.55	4.13	28.87	0.00	Average	188	143	VERTICAL
4	2441.00	103.39			70.39	4.13	28.87	0.00	Peak	188	143	VERTICAL
5	2483.50	47.57	54.00	-6.43	14.52	4.16	28.89	0.00	Average	188	143	VERTICAL
6	2484.66	59.32	74.00	-14.68	26.27	4.16	28.89	0.00	Peak	188	143	VERTICAL

Item 3, 4 are the fundamental frequency at 2441 MHz.

Channel 78

	Freq	Level	Limit Line	Over Limit	Read Level	CableAntenna Loss	Antenna Factor	Preamp Factor	Remark	A/Pos	T/Pos	Pol/Phase
	MHz	dBuV/m	dBuV/m	dB	dBuV	dB	dB/m	dB		cm	deg	
1	2479.80	100.04			66.99	4.16	28.89	0.00	Average	156	110	VERTICAL
2	2480.00	104.76			71.71	4.16	28.89	0.00	Peak	156	110	VERTICAL
3	2483.50	47.55	54.00	-6.45	14.50	4.16	28.89	0.00	Average	156	110	VERTICAL
4	2491.46	60.96	74.00	-13.04	27.89	4.17	28.90	0.00	Peak	156	110	VERTICAL

Item 1, 2 are the fundamental frequency at 2480 MHz.

Note: Both antenna polarizations have been tested and only the worst case was recorded in test report.

Note:

Emission level (dBuV/m) = 20 log Emission level (uV/m).

Corrected Reading: Antenna Factor + Cable Loss + Read Level - Preamp Factor = Level.

Plot on Configuration For BR (GFSK) / Channel 0 / Reference Level (Vertical)

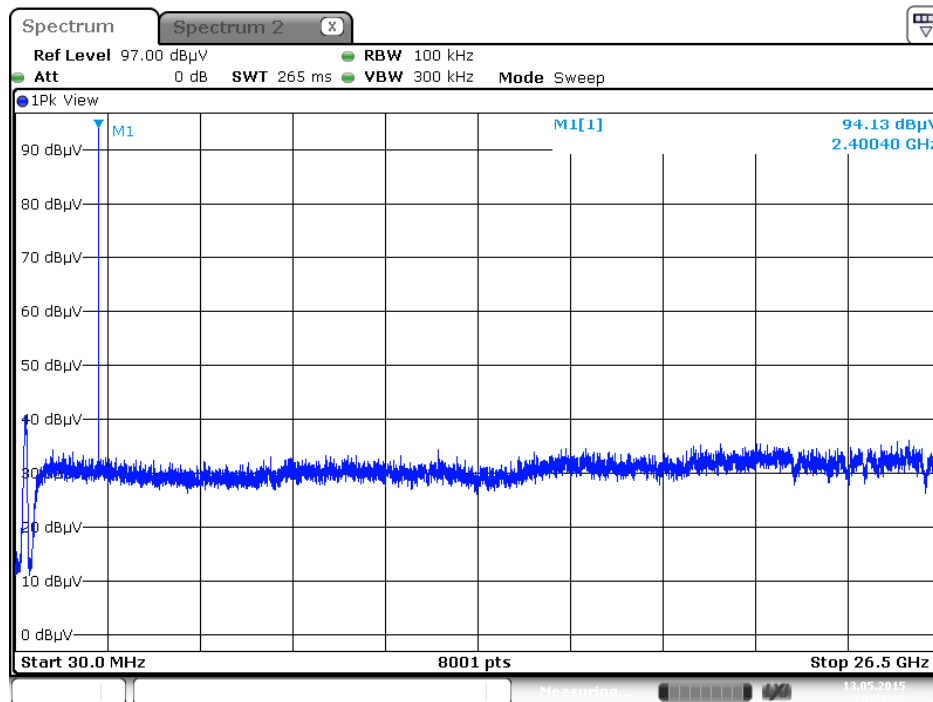

Plot on Configuration For BR (GFSK) / Channel 0 / 30MHz~2400MHz (down 20dBc) (Vertical)

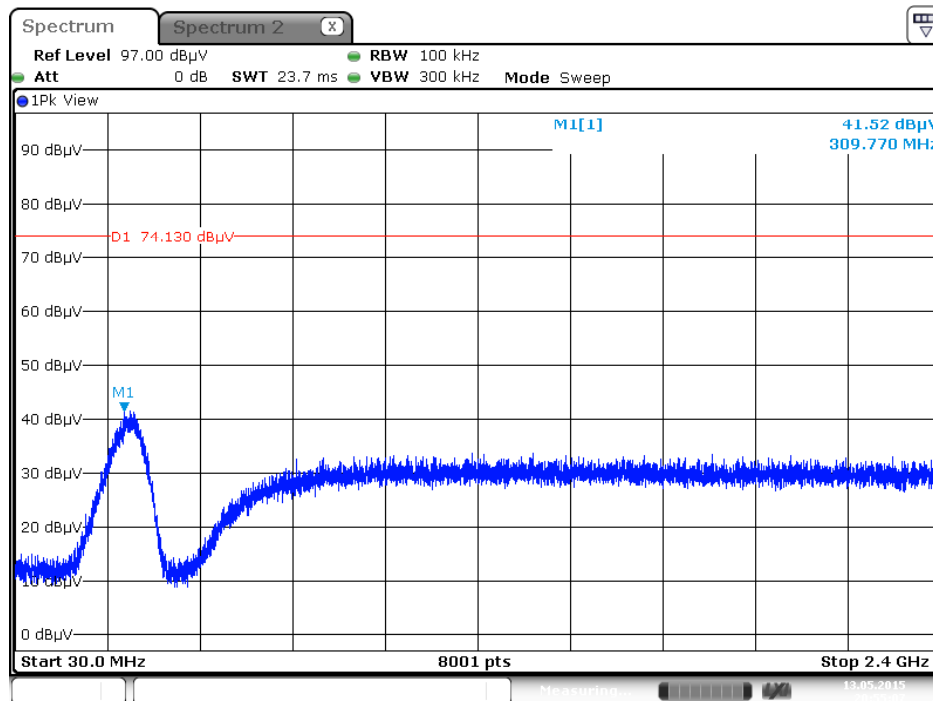

Note: Only the worse polarization (Vertical) is tested and recorded in test report.

Plot on Configuration For BR (GFSK) / Channel 0 / 2390MHz~2400MHz (down 20dBc) (Vertical)

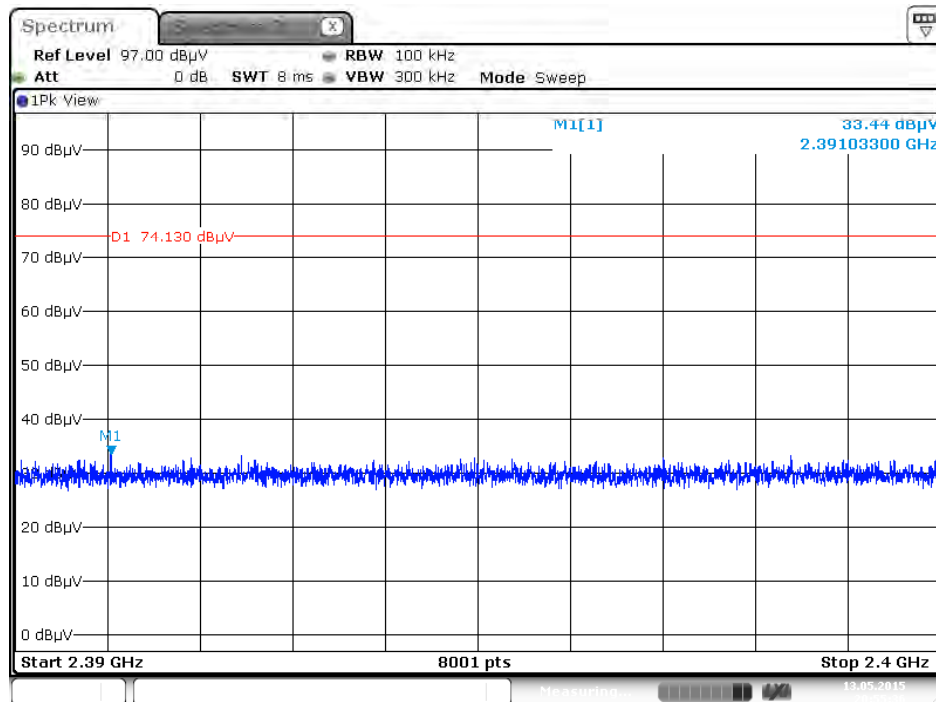

Plot on Configuration For BR (GFSK) / Channel 0 / 2483.5MHz~2500MHz (down 20dBc) (Vertical)

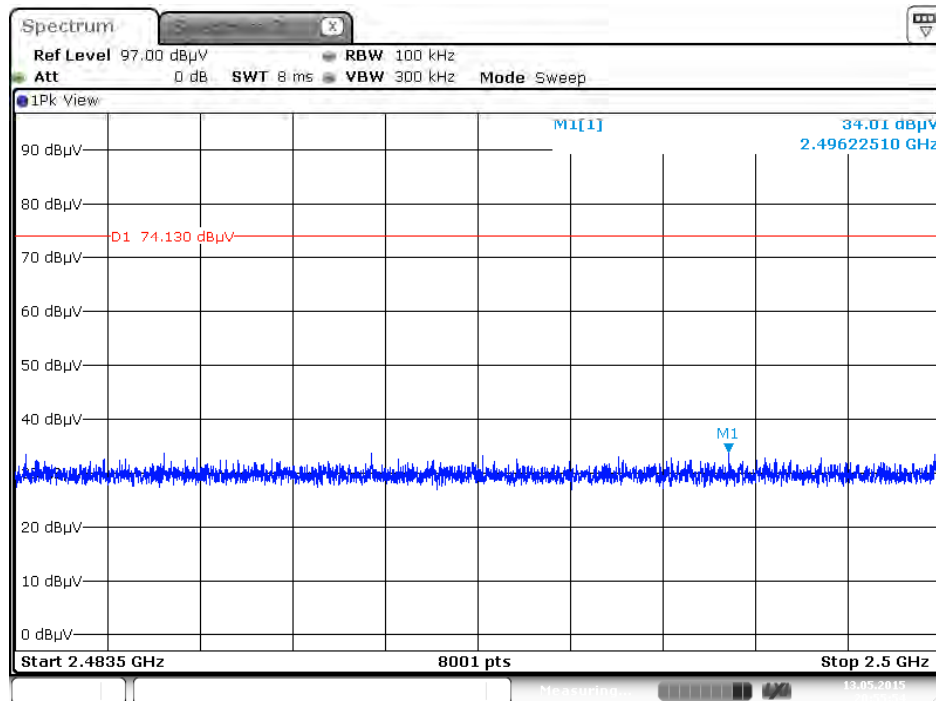

Note: Only the worse polarization (Vertical) is tested and recorded in test report.

Plot on Configuration For BR (GFSK) / Channel 0 / 2500MHz~26500MHz (down 20dBc) (Vertical)

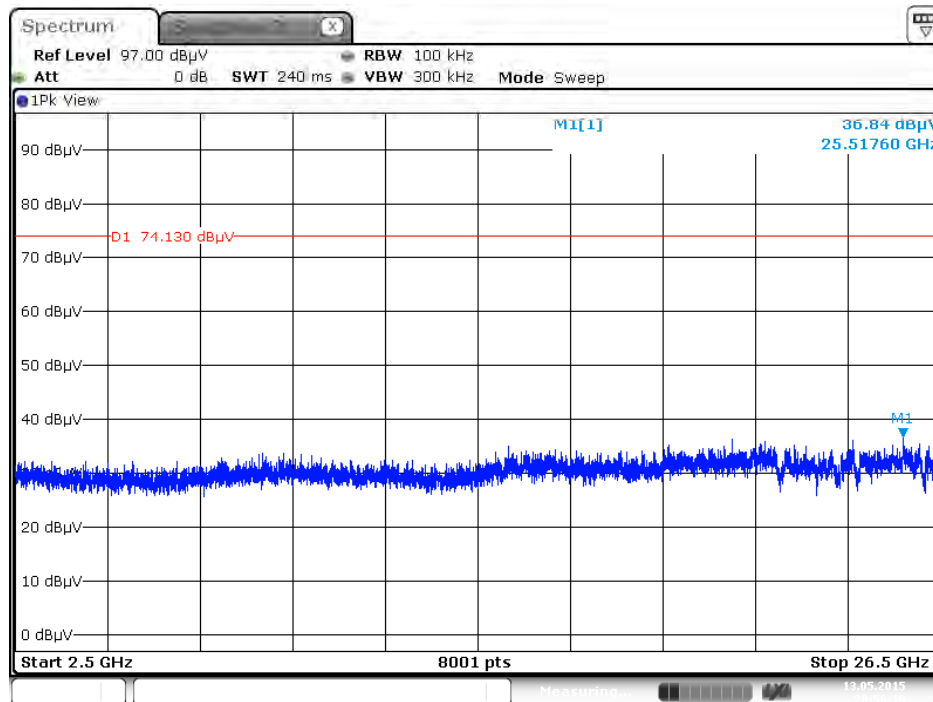

Plot on Configuration For BR (GFSK) / Channel 78 / Reference Level (Vertical)

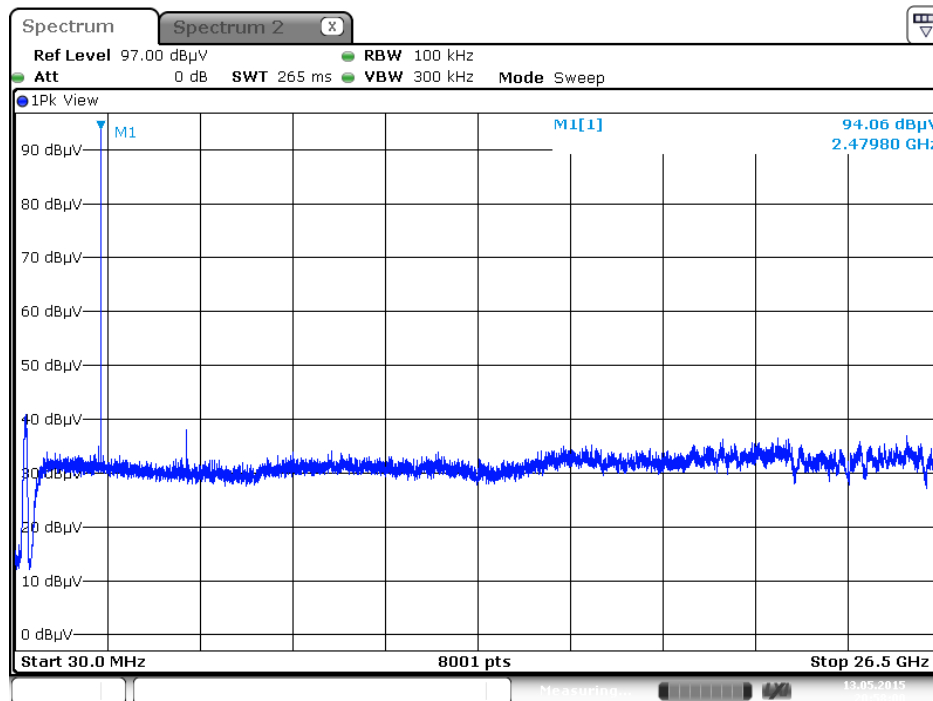

Note: Only the worse polarization (Vertical) is tested and recorded in test report.

Plot on Configuration For BR (GFSK) / Channel 78 / 30MHz~2400MHz (down 20dBc) (Vertical)

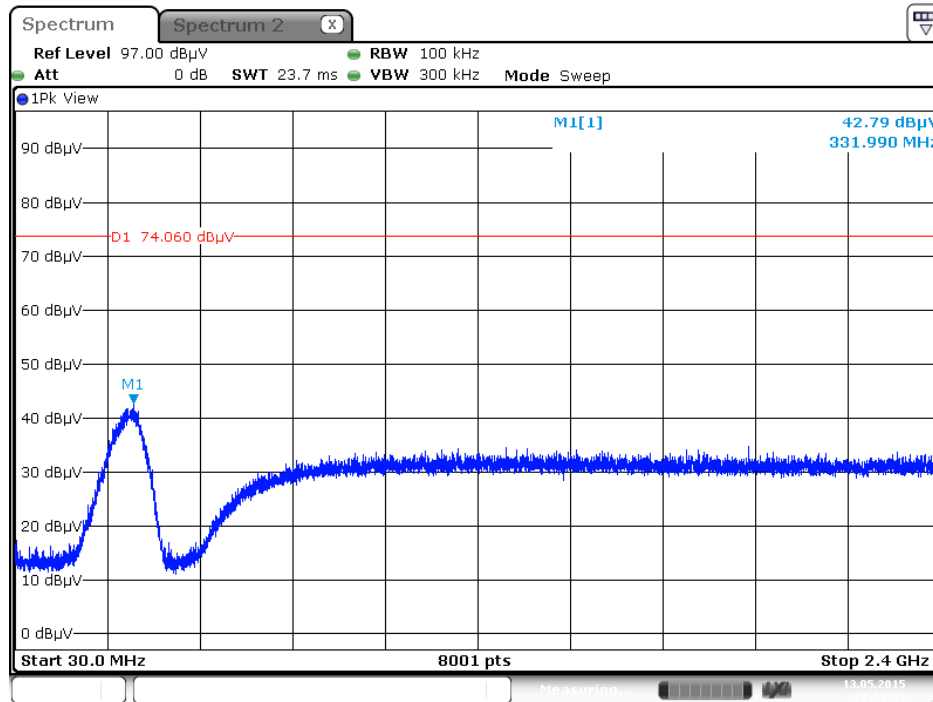

Plot on Configuration For BR (GFSK) / Channel 78 / 2390MHz~2400MHz (down 20dBc) (Vertical)

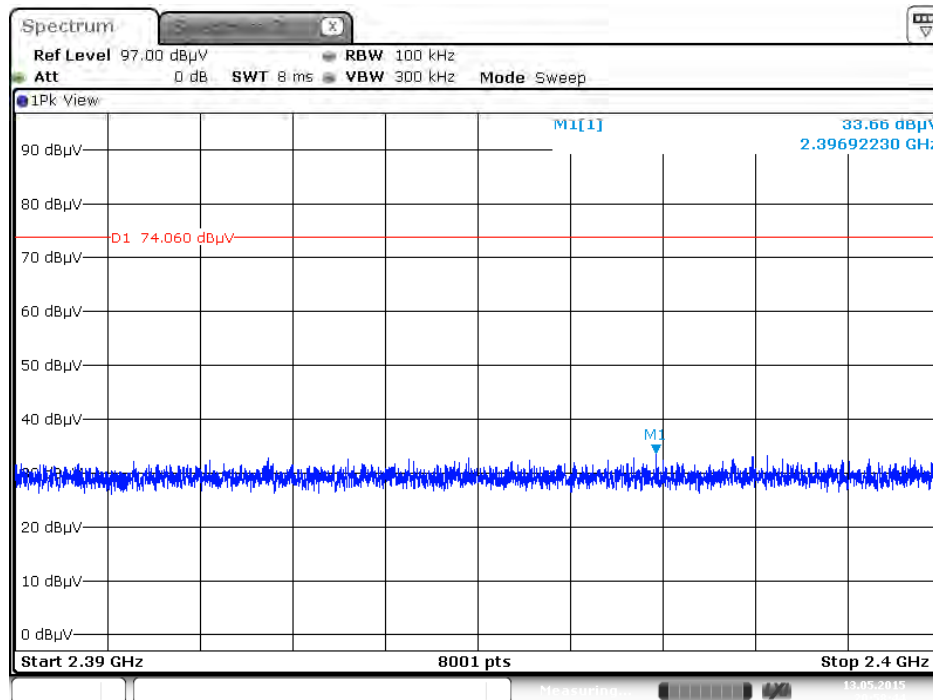

Note: Only the worse polarization (Vertical) is tested and recorded in test report.

Plot on Configuration For BR (GFSK) / Channel 78 / 2483.5MHz~2500MHz (down 20dBc) (Vertical)

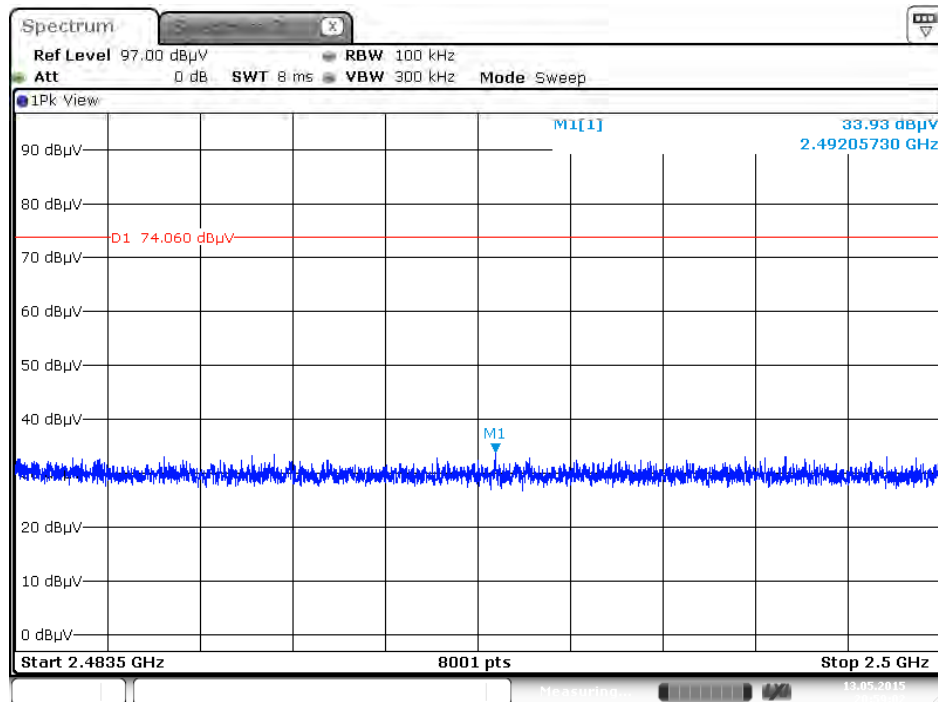

Plot on Configuration For BR (GFSK) / Channel 78 / 2500MHz~2650MHz (down 20dBc) (Vertical)

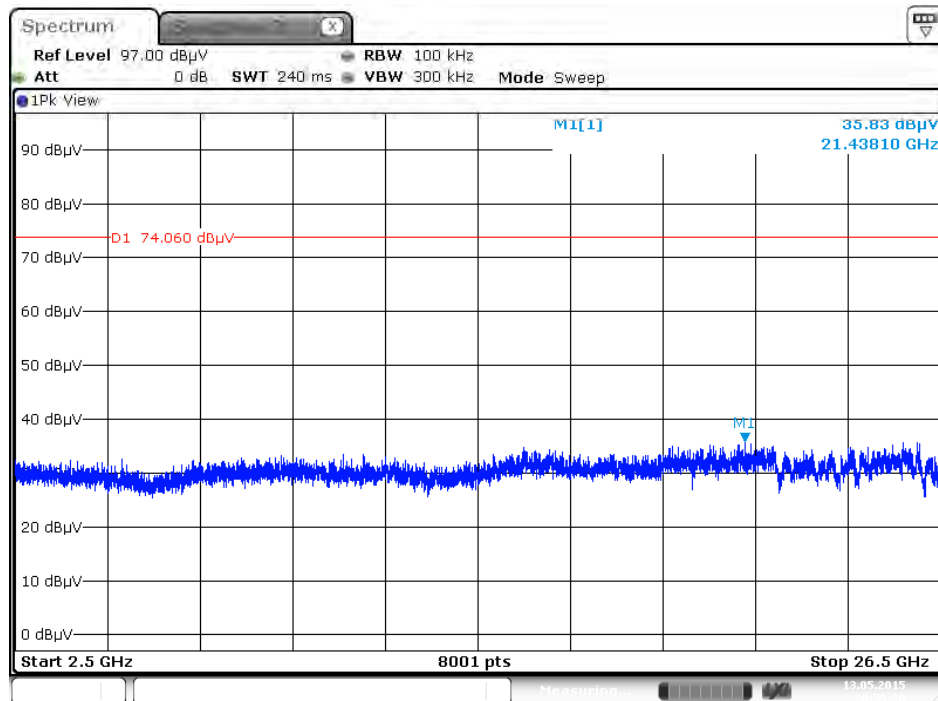

Note: Only the worse polarization (Vertical) is tested and recorded in test report.

Plot on Configuration For BR (GFSK) / Hopping / Reference Level (Vertical)

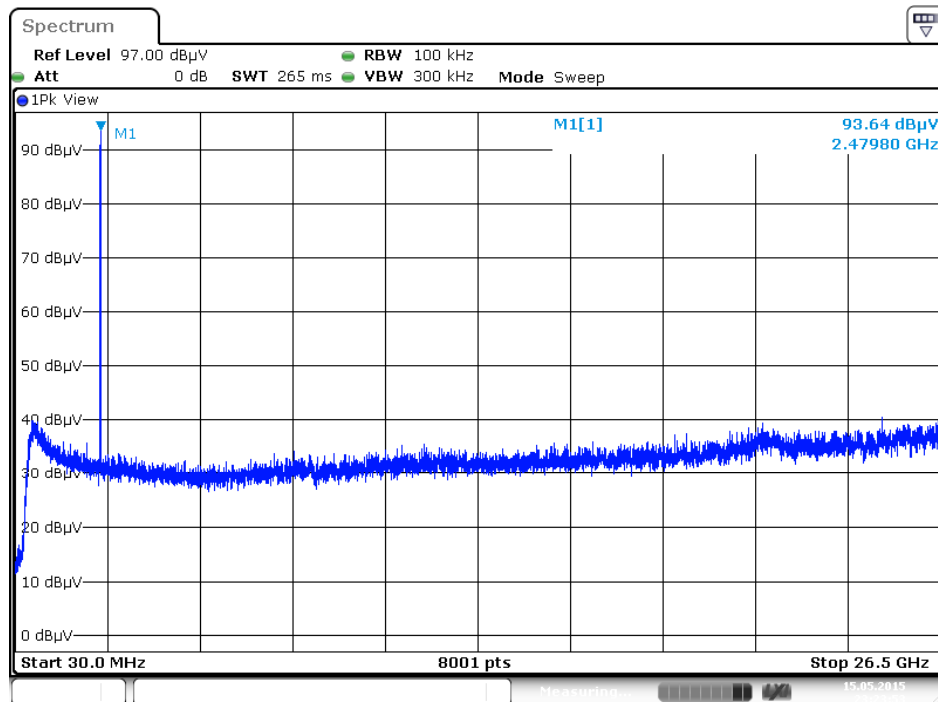

Date: 15 MAY 2015 23:23:53

Plot on Configuration For BR (GFSK) / Hopping / 30MHz~2400MHz (down 20dBc) (Vertical)

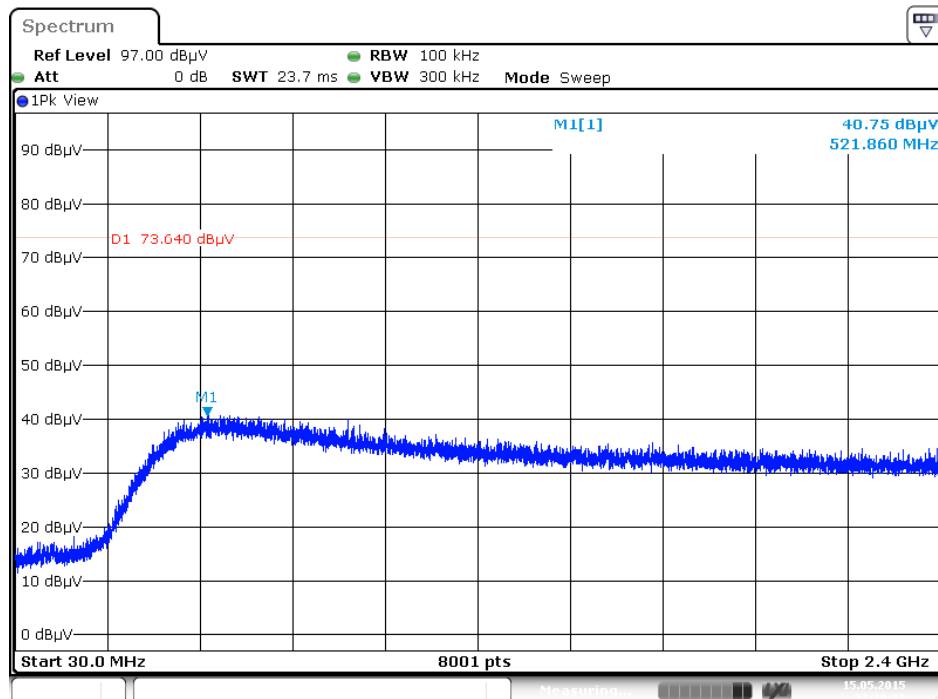

Date: 15 MAY 2015 23:29:38

Note: Only the worse polarization (Vertical) is tested and recorded in test report.

Plot on Configuration For BR (GFSK) / Hopping / 2390MHz~2400MHz (down 20dBc) (Vertical)

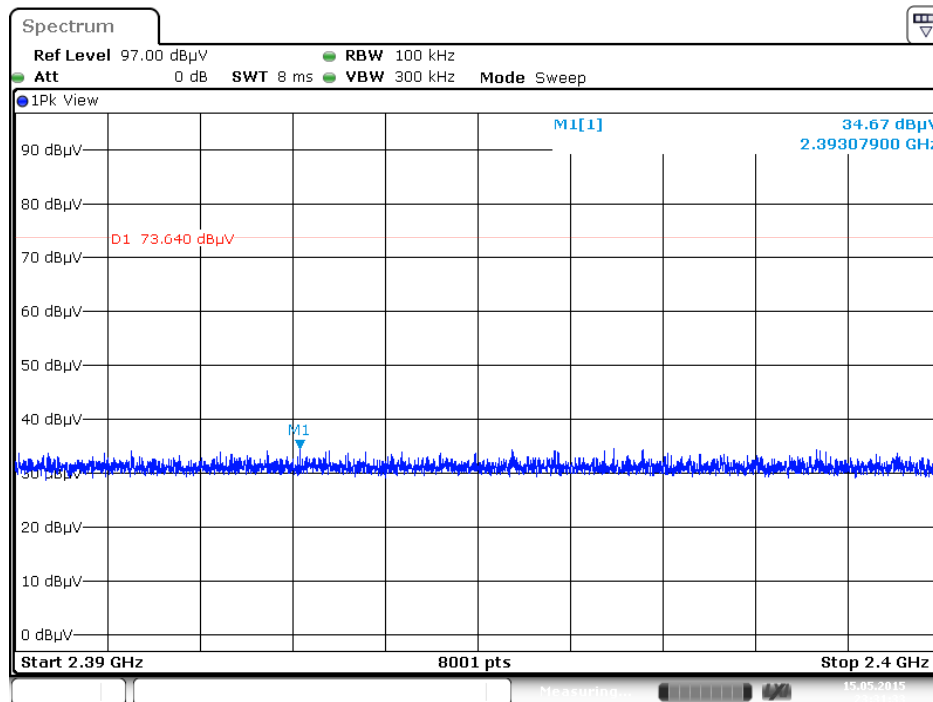

Plot on Configuration For BR (GFSK) / Hopping / 2483.5MHz~2500MHz (down 20dBc) (Vertical)

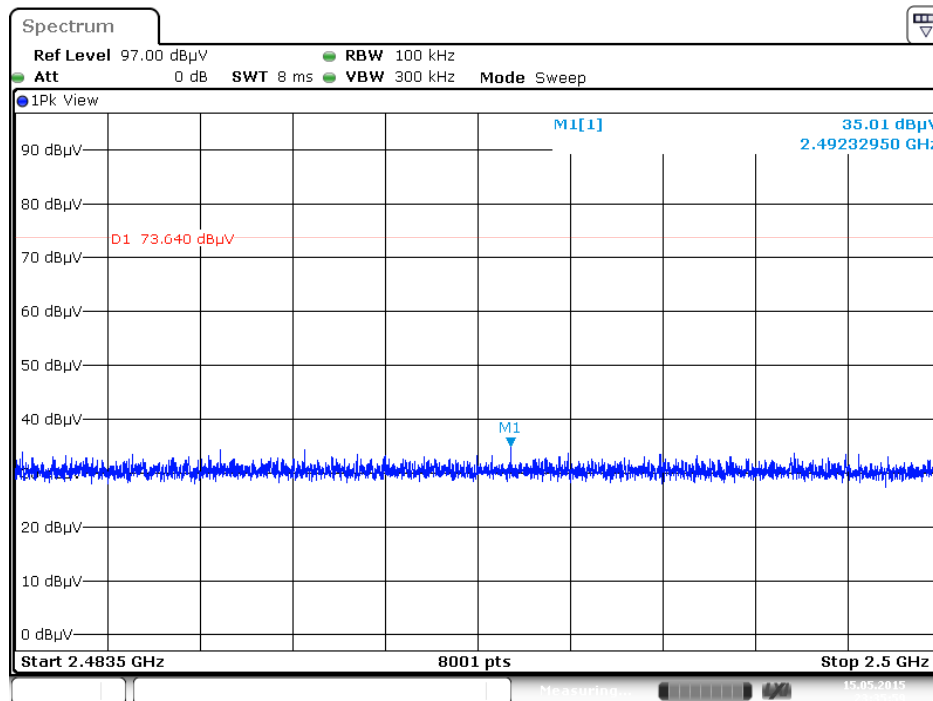

Note: Only the worse polarization (Vertical) is tested and recorded in test report.

Plot on Configuration For BR (GFSK) / Hopping / 2500MHz~26500MHz (down 20dBc) (Vertical)

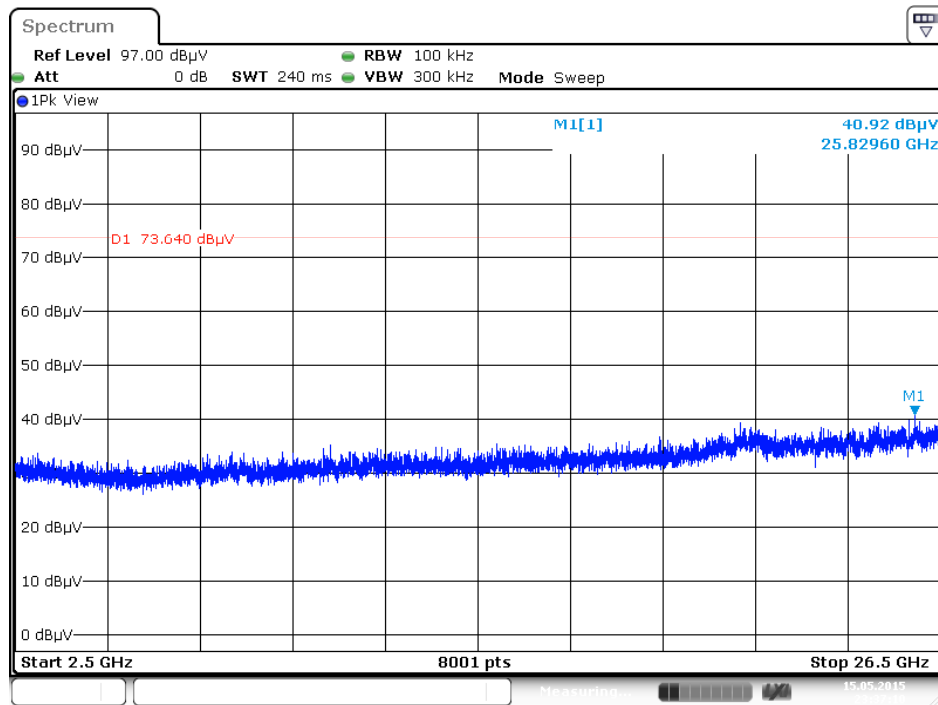

Date: 15 MAY 2015 23:37:10

Note: Only the worse polarization (Vertical) is tested and recorded in test report.

Plot on Configuration For EDR (8DPSK) / Channel 0 / Reference Level (Vertical)

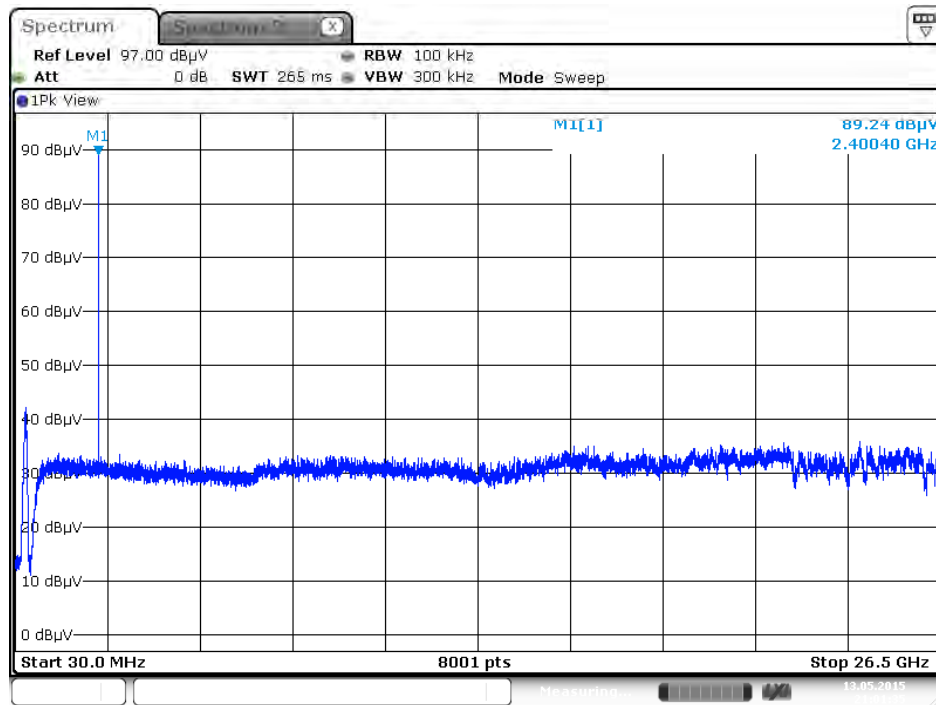

Date: 13.MAY.2015 21:01:36

Plot on Configuration For EDR (8DPSK) / Channel 0 / 30MHz~2400MHz (down 20dBc) (Vertical)

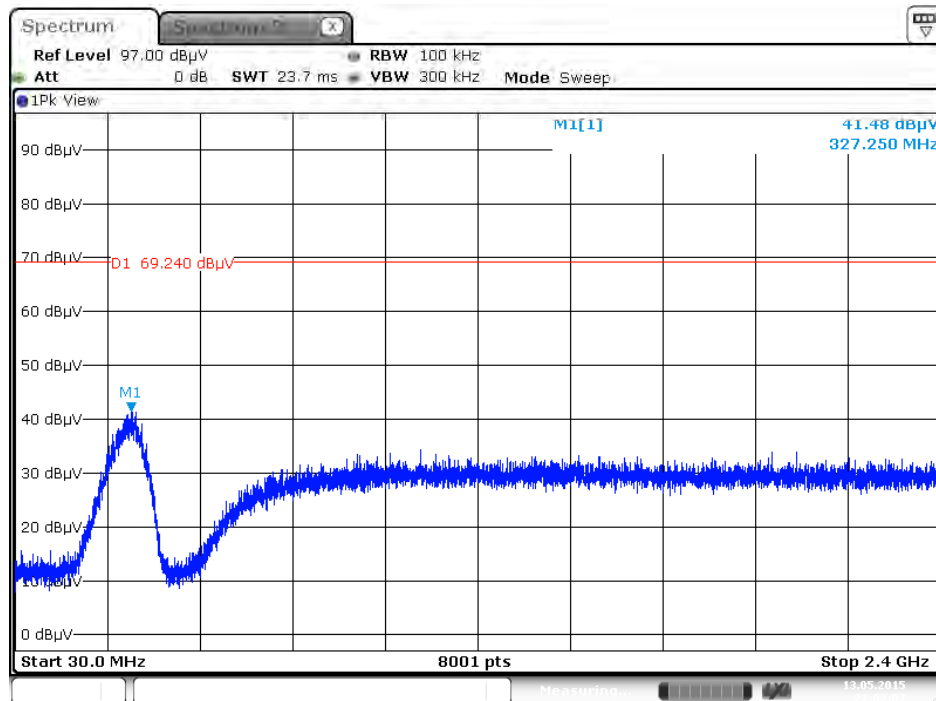

Date: 13.MAY.2015 21:02:08

Note: Only the worse polarization (Vertical) is tested and recorded in test report.

Plot on Configuration For EDR (8DPSK) / Channel 0 / 2390MHz~2400MHz (down 20dBc) (Vertical)

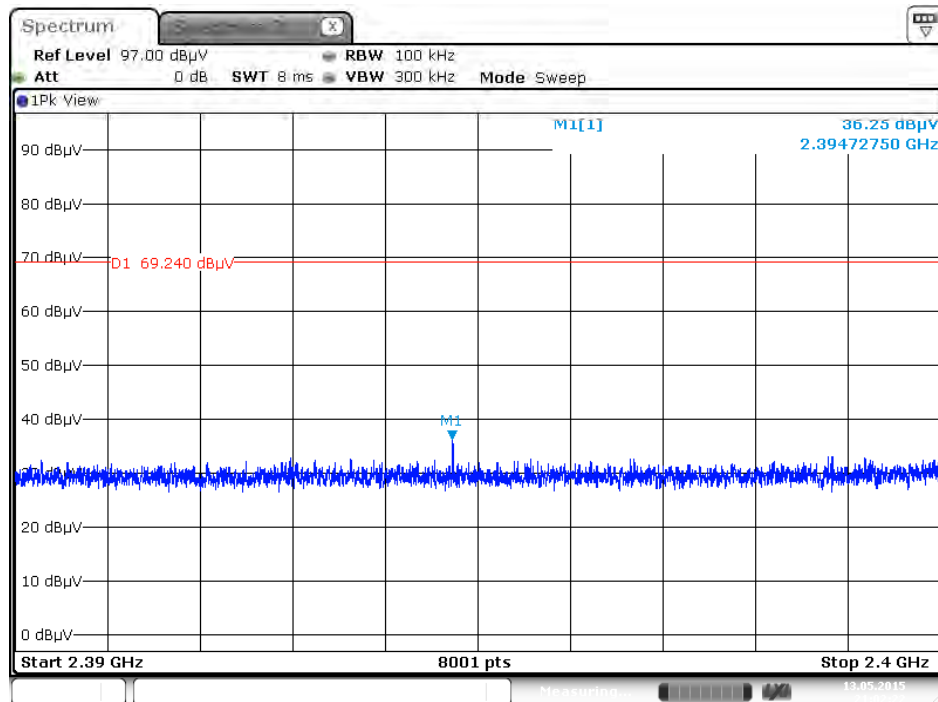

Date: 13.MAY.2015 21:02:23

Plot on Configuration For EDR (8DPSK) / Channel 0 / 2483.5MHz~2500MHz (down 20dBc) (Vertical)

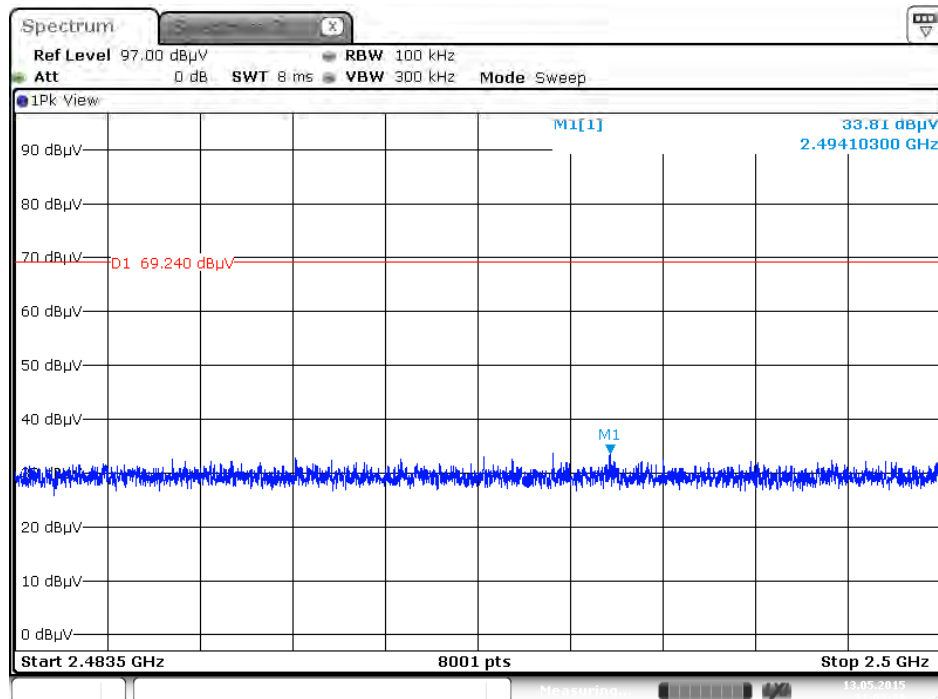

Date: 13.MAY.2015 21:02:38

Note: Only the worse polarization (Vertical) is tested and recorded in test report.

Plot on Configuration For EDR (8DPSK) / Channel 0 / 2500MHz~26500MHz (down 20dBc) (Vertical)

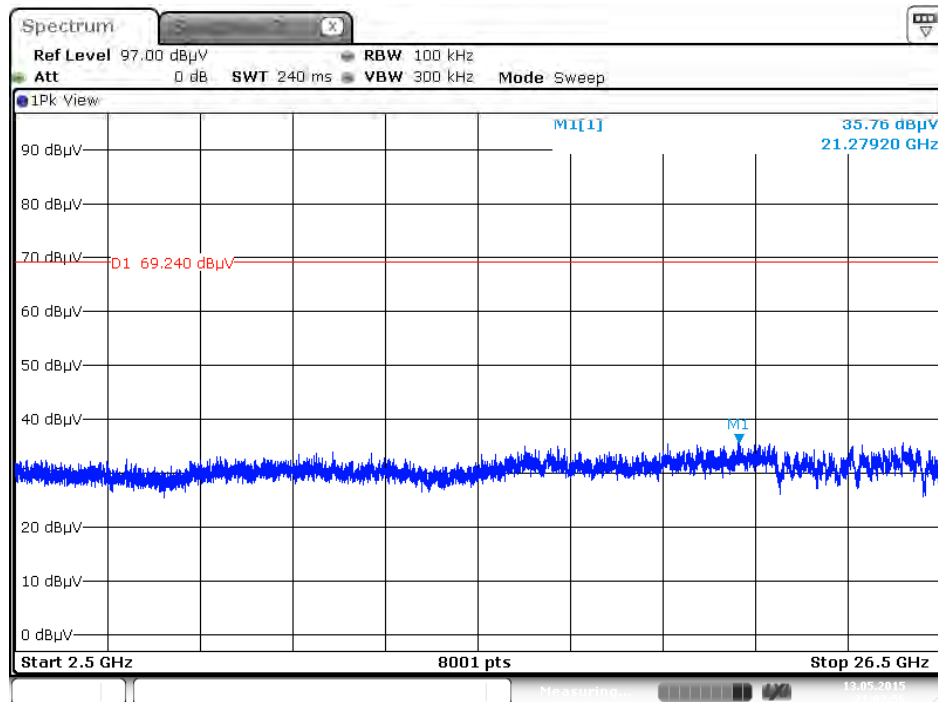

Plot on Configuration For EDR (8DPSK) / Channel 78 / Reference Level (Vertical)

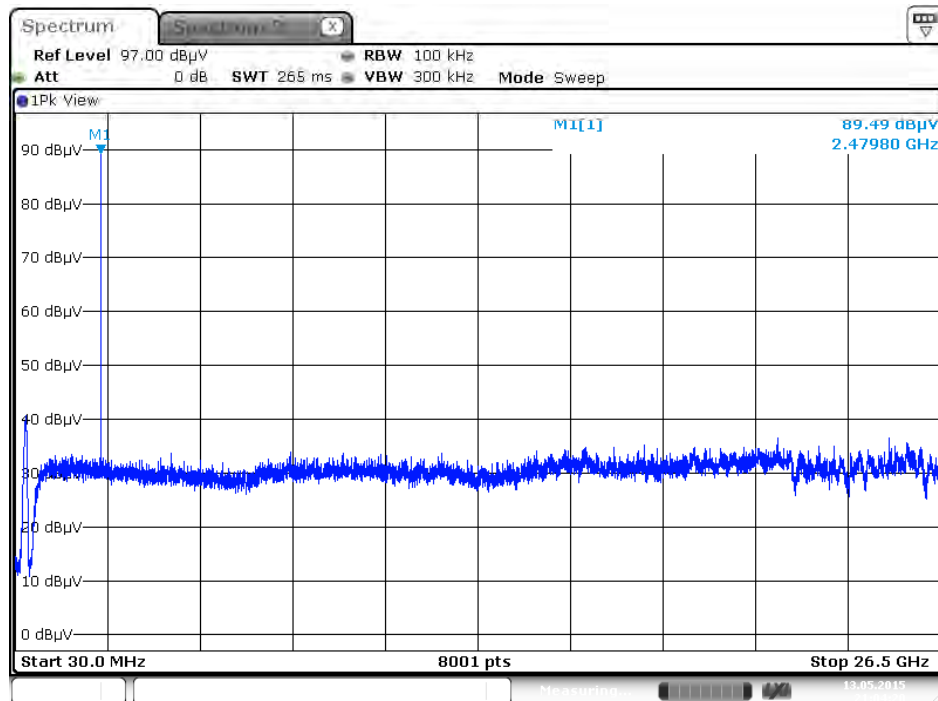

Note: Only the worse polarization (Vertical) is tested and recorded in test report.

Plot on Configuration For EDR (8DPSK) / Channel 78 / 30MHz~2400MHz (down 20dBc) (Vertical)

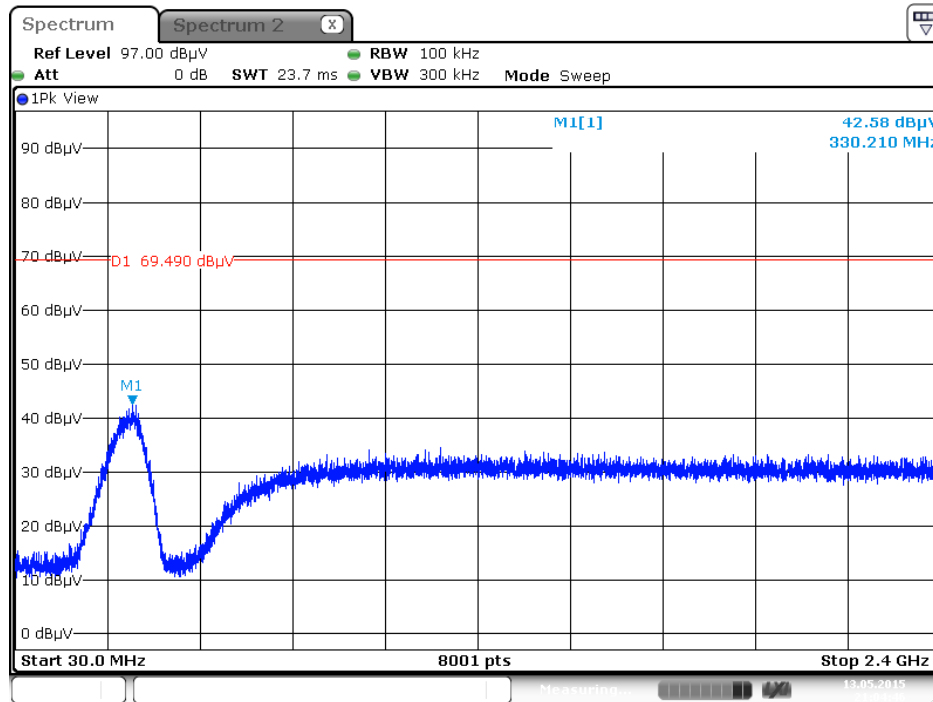

Plot on Configuration For EDR (8DPSK) / Channel 78 / 2390MHz~2400MHz (down 20dBc) (Vertical)

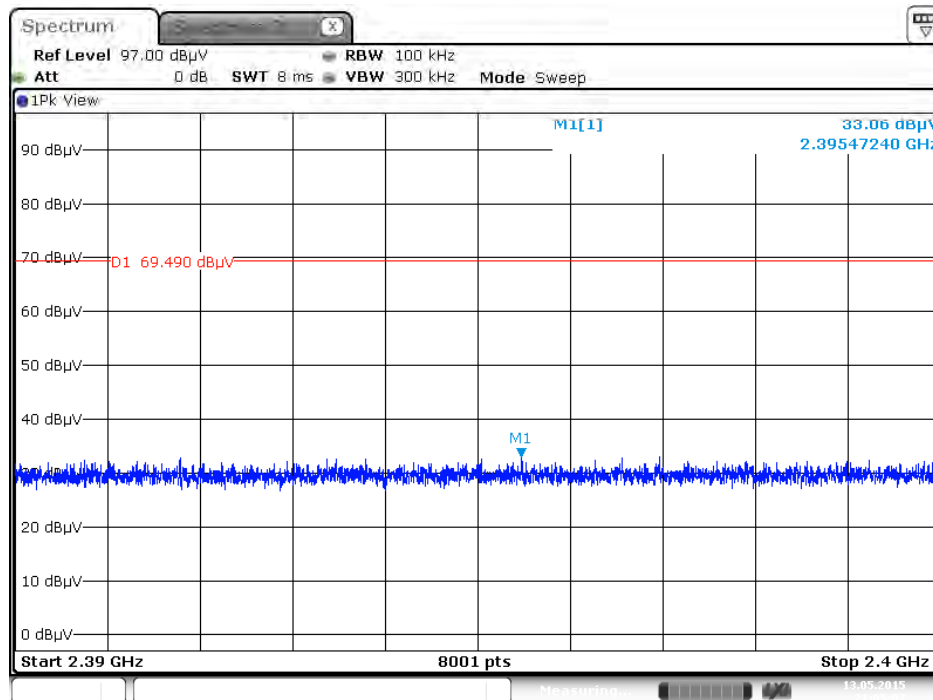

Note: Only the worse polarization (Vertical) is tested and recorded in test report.

Plot on Configuration For EDR (8DPSK) / Channel 78 / 2483.5MHz~2500MHz (down 20dBc) (Vertical)

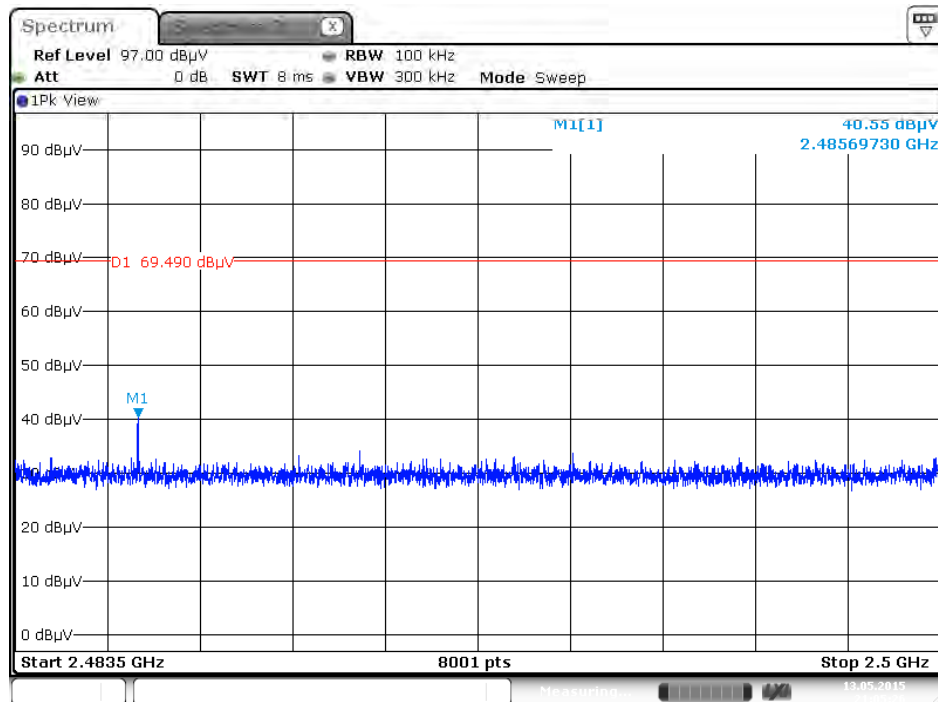

Plot on Configuration For EDR (8DPSK) / Channel 78 / 2500MHz~26500MHz (down 20dBc) (Vertical)

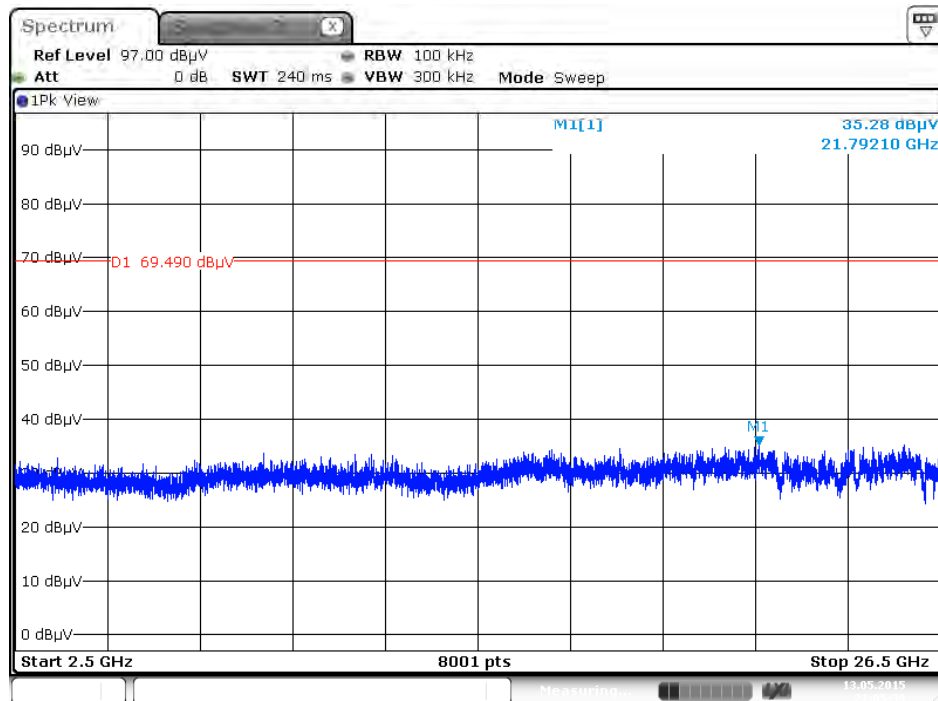

Note: Only the worse polarization (Vertical) is tested and recorded in test report.

Plot on Configuration For EDR (8DPSK) / Hopping / Reference Level (Vertical)

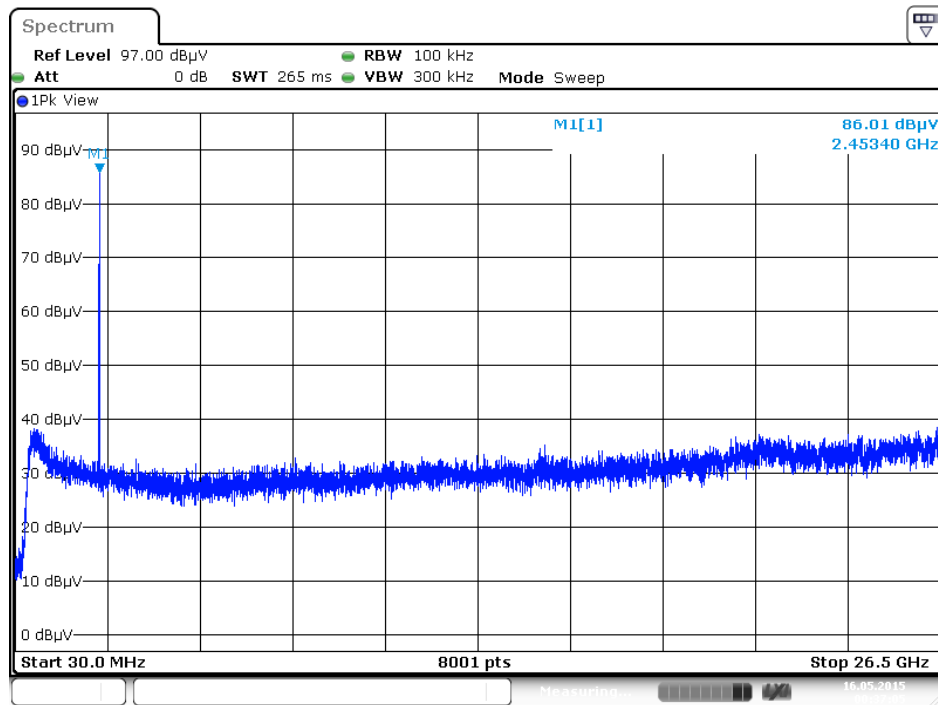

Plot on Configuration For EDR (8DPSK) / Hopping / 30MHz~2400MHz (down 20dBc) (Vertical)

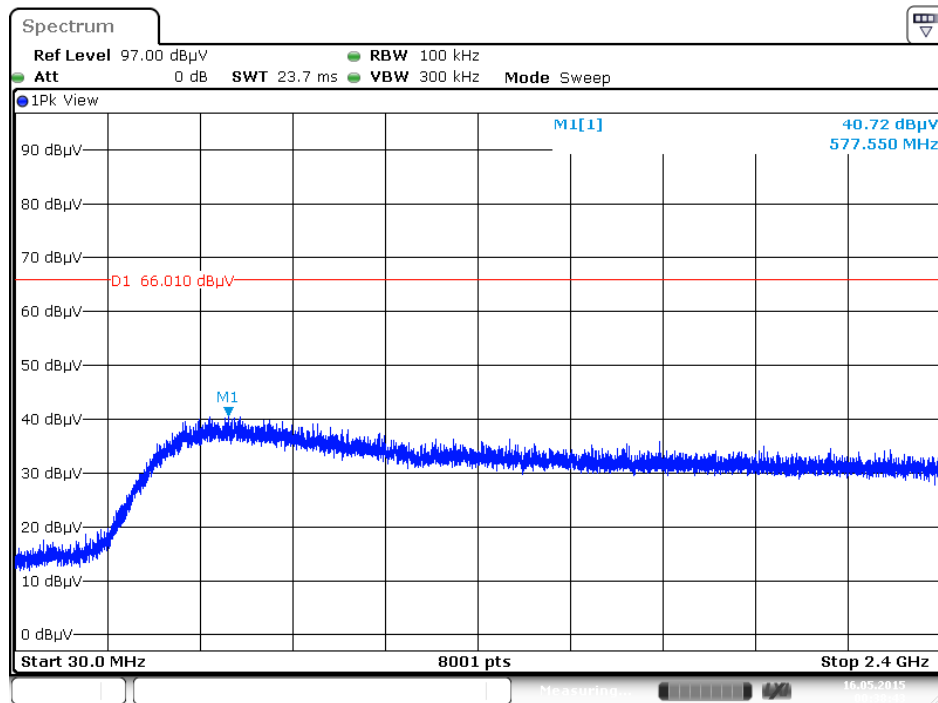

Note: Only the worse polarization (Vertical) is tested and recorded in test report.

Plot on Configuration For EDR (8DPSK) / Hopping / 2390MHz~2400MHz (down 20dBc) (Vertical)

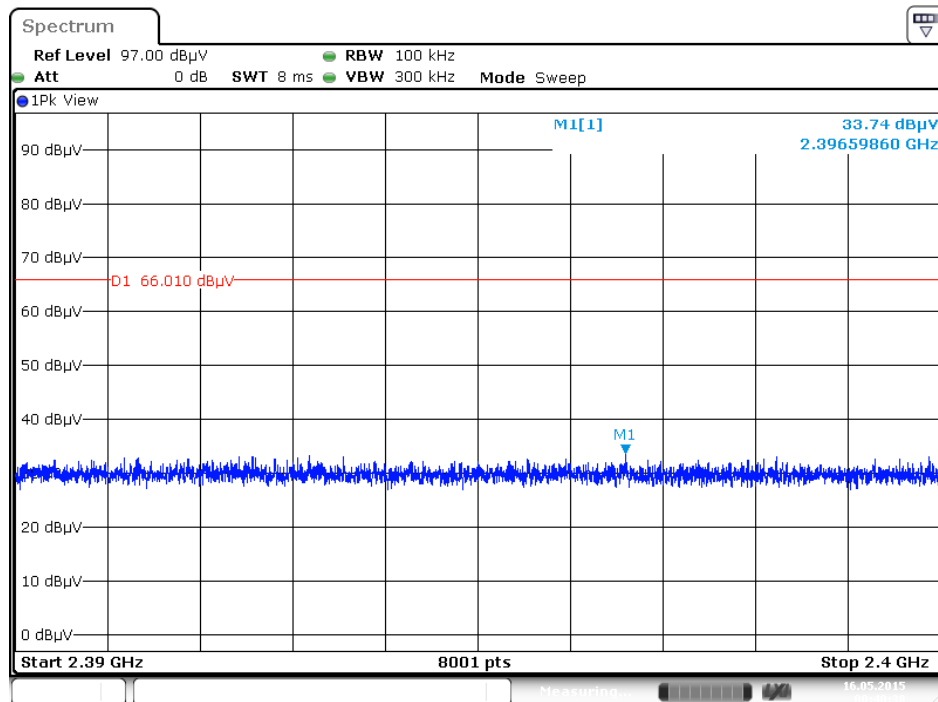

Plot on Configuration For EDR (8DPSK) / Hopping / 2483.5MHz~2500MHz (down 20dBc) (Vertical)

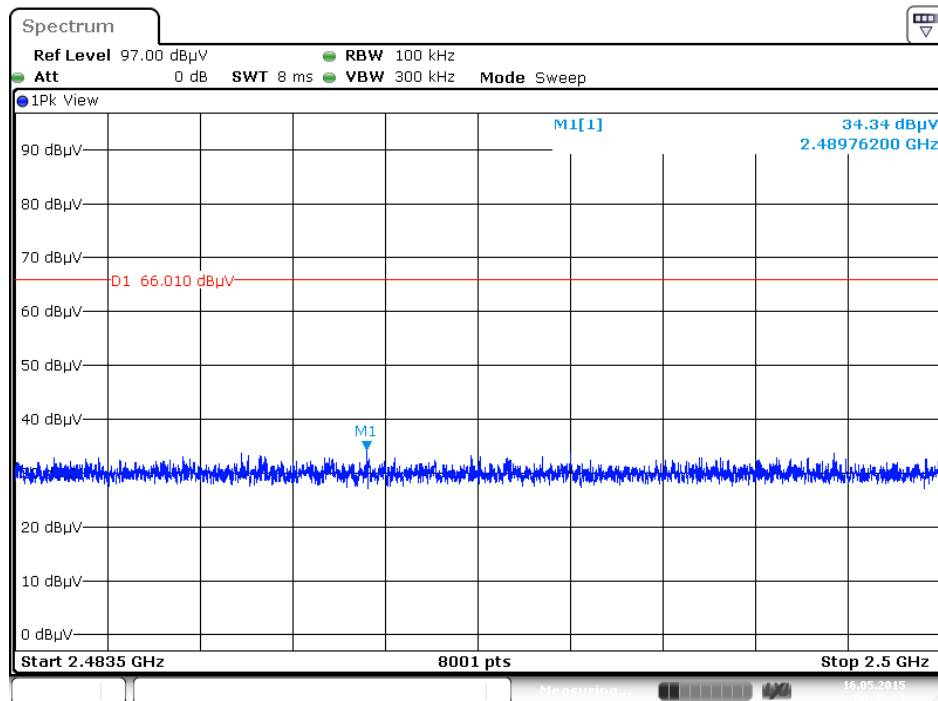

Note: Only the worse polarization (Vertical) is tested and recorded in test report.

Plot on Configuration For EDR (8DPSK) / Hopping / 2500MHz~26500MHz (down 20dBc) (Vertical)

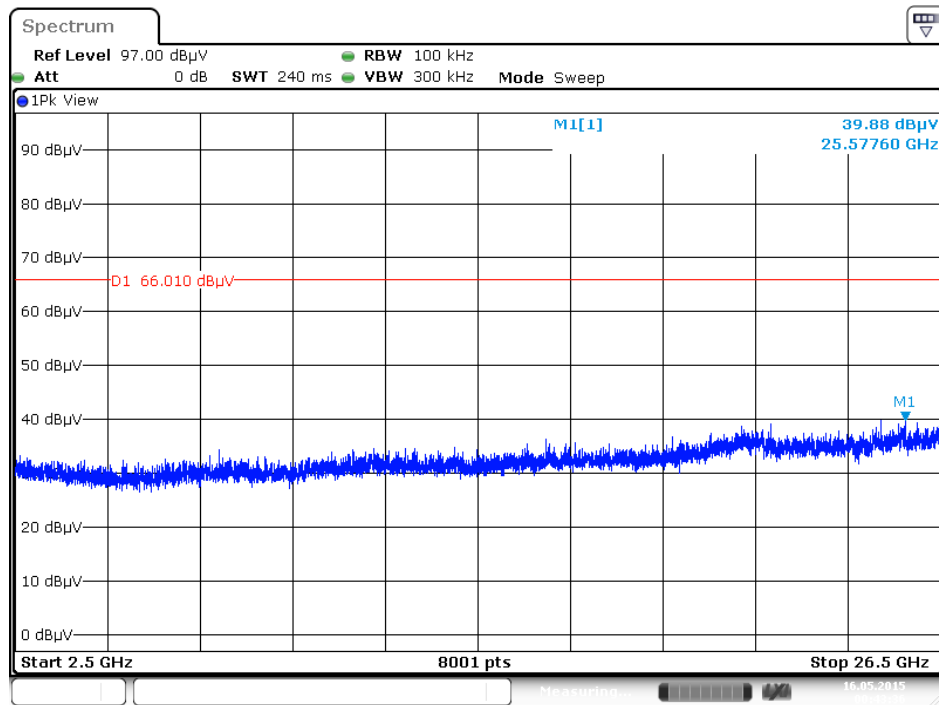

Date: 16 MAY 2015 00:43:36

Note: Only the worse polarization (Vertical) is tested and recorded in test report.

4.3. Antenna Requirements

4.3.1. Limit

Except for special regulations, the Low-power Radio-frequency Devices must not be equipped with any jacket for installing an antenna with extension cable. An intentional radiator shall be designed to ensure that no antenna other than that furnished by the responsible party shall be used with the device. The use of a permanently attached antenna or of an antenna that uses a unique coupling to the intentional radiator shall be considered sufficient to comply with the provisions of this Section. The manufacturer may design the unit so that the user can replace a broken antenna, but the use of a standard antenna jack or electrical connector is prohibited.

4.3.2. Antenna Connector Construction

Please refer to section 3.3 in this test report, antenna connector complied with the requirements.

5. LIST OF MEASURING EQUIPMENTS

Instrument	Manufacturer	Model No.	Serial No.	Characteristics	Calibration Date	Remark
BILOG ANTENNA	Schaffner	CBL6112D	22021	20MHz ~ 2GHz	May 26, 2014	Radiation (03CH01-CB)
Horn Antenna	EMCO	3115	00075790	750MHz ~ 18GHz	Oct. 28, 2014	Radiation (03CH01-CB)
Horn Antenna	Schwarzbeck	BBHA 9170	BBHA9170252	15GHz ~ 40GHz	Aug. 22, 2014	Radiation (03CH01-CB)
Pre-Amplifier	Agilent	8447D	2944A10991	0.1MHz ~ 1.3GHz	Feb. 24, 2015	Radiation (03CH01-CB)
Pre-Amplifier	Agilent	8449B	3008A02310	1GHz ~ 26.5GHz	Jan. 12, 2015	Radiation (03CH01-CB)
Spectrum Analyzer	R&S	FSP40	100056	9kHz ~ 40GHz	Nov. 06, 2014	Radiation (03CH01-CB)
EMI Test Receiver	Agilent	N9038A	MY52260123	9kHz ~ 8GHz	Jan. 21, 2015	Radiation (03CH01-CB)
Turn Table	INN CO	CO 2000	N/A	0 ~ 360 degree	N.C.R.	Radiation (03CH01-CB)
Antenna Mast	INN CO	CO 2000	N/A	1 m ~ 4 m	N.C.R.	Radiation (03CH01-CB)
RF Cable-low	Woken	Low Cable-1	N/A	30 MHz ~ 1 GHz	Nov. 15, 2014	Radiation (03CH01-CB)
RF Cable-high	Woken	High Cable-16	N/A	1 GHz ~ 18 GHz	Nov. 15, 2014	Radiation (03CH01-CB)
RF Cable-high	Woken	High Cable-17	N/A	1 GHz ~ 18 GHz	Nov. 15, 2014	Radiation (03CH01-CB)
RF Cable-high	Woken	High Cable-40G-1	N/A	1 GHz ~ 40 GHz	Nov. 15, 2014	Radiation (03CH01-CB)
RF Cable-high	Woken	High Cable-40G-2	N/A	1 GHz ~ 40 GHz	Nov. 15, 2014	Radiation (03CH01-CB)
Thermometer	HTC-1	HTC-1	TP-1	-50°C~70°C	Mar. 11, 2015	Radiation (03CH01-CB)
Loop Antenna	Teseq	HLA 6120	24155	9kHz - 30 MHz	Mar. 12, 2015	Radiation (03CH01-CB)

Note: Calibration Interval of instruments listed above is one year.

N.C.R. means Non-Calibration required.

6. MEASUREMENT UNCERTAINTY

Test Items	Uncertainty	Remark
Radiated Emission (30MHz ~ 1,000MHz)	3.6 dB	Confidence levels of 95%
Radiated Emission (1GHz ~ 18GHz)	3.7 dB	Confidence levels of 95%
Radiated Emission (18GHz ~ 40GHz)	3.5 dB	Confidence levels of 95%