



SPORTON International Inc.

No. 52, Hwa Ya 1st Rd., Hwa Ya Technology Park, Kwei-Shan Hsiang, Tao Yuan Hsien, Taiwan, R.O.C.
Ph: 886-3-327-3456 / FAX: 886-3-327-0973 / www.sporton.com.tw

FCC RADIO TEST REPORT

Applicant's company	Broadcom Corporation
Applicant Address	190 Mathilda Place Sunnyvale CA 94086 U.S.A.
FCC ID	QDS-BRCM1084
Manufacturer's company	Broadcom Corporation
Manufacturer Address	190 Mathilda Place Sunnyvale CA 94086 U.S.A.

Product Name	Broadcom 802.11a/b/g/n WLAN+ Bluetooth PCI-E NGFF2230 card
Brand Name	Broadcom
Model No.	BCM943228Z
Test Rule Part(s)	47 CFR FCC Part 15 Subpart E § 15.407
Test Freq. Range	5150 ~ 5350MHz / 5470 ~ 5725MHz / 5725 ~ 5850 MHz
Received Date	Apr. 01, 2014
Final Test Date	Oct. 15, 2015
Submission Type	Class II Change

Statement

Test result included is for the IEEE 802.11n and IEEE 802.11a of the product.

The test result in this report refers exclusively to the presented test model / sample.

Without written approval of SPORTON International Inc., the test report shall not be reproduced except in full.

The measurements and test results shown in this test report were made in accordance with the procedures and found in compliance with the limit given in **ANSI C63.10-2013, 47 CFR FCC Part 15 Subpart E, KDB789033 D02 v01, KDB662911 D01 v02r01.**

The test equipment used to perform the test is calibrated and traceable to NML/ROC.



Table of Contents

1. VERIFICATION OF COMPLIANCE	1
2. SUMMARY OF THE TEST RESULT	2
3. GENERAL INFORMATION	3
3.1. Product Details.....	3
3.2. Accessories.....	4
3.3. Table for Filed Antenna.....	5
3.4. Table for Carrier Frequencies	6
3.5. Table for Test Modes	7
3.6. Table for Testing Locations.....	8
3.7. Table for Class II Change	8
3.8. Table for Supporting Units	8
3.9. Table for Parameters of Test Software Setting	9
3.10. EUT Operation during Test	9
3.11. Duty Cycle.....	9
3.12. Test Configurations	10
4. TEST RESULT	11
4.1. 26dB Bandwidth and 99% Occupied Bandwidth Measurement.....	11
4.2. 6dB Spectrum Bandwidth Measurement	22
4.3. Maximum Conducted Output Power Measurement.....	28
4.4. Power Spectral Density Measurement	31
4.5. Radiated Emissions Measurement	37
4.6. Band Edge Emissions Measurement	56
4.7. Frequency Stability Measurement	65
4.8. Antenna Requirements	68
5. LIST OF MEASURING EQUIPMENTS	69
6. MEASUREMENT UNCERTAINTY	70
APPENDIX A. TEST PHOTOS	A1 ~ A2



History of This Test Report

REPORT NO.	VERSION	DESCRIPTION	ISSUED DATE
FR440181-05	Rev. 01	Initial issue of report	Oct. 21, 2015
FR440181-05	Rev. 02	Updating 5GHz B1~B3 to "New Rules".	Dec. 28, 2015



1. VERIFICATION OF COMPLIANCE

Product Name : Broadcom 802.11a/b/g/n WLAN+ Bluetooth PCI-E NGFF2230 card
Brand Name : Broadcom
Model No. : BCM943228Z
Applicant : Broadcom Corporation
Test Rule Part(s) : 47 CFR FCC Part 15 Subpart E § 15.407

Sporton International as requested by the applicant to evaluate the EMC performance of the product sample received on Apr. 01, 2014 would like to declare that the tested sample has been evaluated and found to be in compliance with the tested rule parts. The data recorded as well as the test configuration specified is true and accurate for showing the sample's EMC nature.

A handwritten signature in blue ink that reads "Sam Chen".

Sam Chen
SPORTON INTERNATIONAL INC.

2. SUMMARY OF THE TEST RESULT

Applied Standard: 47 CFR FCC Part 15 Subpart E				
Part	Rule Section	Description of Test	Result	Under Limit
4.1	15.407(a)	26dB Spectrum Bandwidth and 99% Occupied Bandwidth	Complies	-
4.2	15.407(e)	6dB Spectrum Bandwidth	Complies	-
4.3	15.407(a)	Maximum Conducted Output Power	Complies	5.90 dB
4.4	15.407(a)	Power Spectral Density	Complies	19.06 dB
4.5	15.407(b)	Radiated Emissions	Complies	2.03 dB
4.6	15.407(b)	Band Edge Emissions	Complies	0.04 dB
4.7	15.407(g)	Frequency Stability	Complies	-
4.8	15.203	Antenna Requirements	Complies	-

3. GENERAL INFORMATION

3.1. Product Details

Items	Description
Product Type	WLAN (2TX, 2RX)
Radio Type	Intentional Transceiver
Power Type	From host system
Modulation	IEEE 802.11a: OFDM IEEE 802.11n: see the below table
Data Modulation	IEEE 802.11a/n: OFDM (BPSK / QPSK / 16QAM / 64QAM)
Data Rate (Mbps)	IEEE 802.11a: OFDM (6/9/12/18/24/36/48/54) IEEE 802.11n: see the below table
Frequency Range	5150 ~ 5350MHz / 5470 ~ 5725MHz / 5725 ~ 5850 MHz
Channel Number	24 for 20MHz bandwidth ; 11 for 40MHz bandwidth
Channel Band Width (99%)	IEEE 802.11a: 31.69 MHz IEEE 802.11n MCS0 (HT20): 35.43 MHz IEEE 802.11n MCS0 (HT40): 40.38 MHz
Maximum Conducted Output Power	IEEE 802.11a: 23.89 dBm IEEE 802.11n MCS0 (HT20): 23.52 dBm IEEE 802.11n MCS0 (HT40): 18.11 dBm
Carrier Frequencies	Please refer to section 3.4
Antenna	Please refer to section 3.3

Note: The MIMO transmission mode is correlated.

Items	Description	
Communication Mode	<input checked="" type="checkbox"/> IP Based (Load Based)	<input type="checkbox"/> Frame Based
TPC Function	<input checked="" type="checkbox"/> With TPC	<input type="checkbox"/> Without TPC
Weather Band (5600~5650MHz)	<input checked="" type="checkbox"/> With 5600~5650MHz	<input type="checkbox"/> Without 5600~5650MHz
Beamforming Function	<input type="checkbox"/> With beamforming	<input checked="" type="checkbox"/> Without beamforming

Antenna and Band width

Antenna	Single (TX)		Two (TX)	
	20 MHz	40 MHz	20 MHz	40 MHz
IEEE 802.11a	X	X	V	X
IEEE 802.11n	X	X	V	V

IEEE 11n Spec.

Protocol	Number of Transmit Chains (NTX)	Data Rate / MCS
802.11n (HT20)	2	MCS0-15
802.11n (HT40)	2	MCS0-15

Note 1: IEEE Std. 802.11n modulation consists of HT20 and HT40 (HT: High Throughput).
Then EUT supports HT20 and HT40.

Note 2: Modulation modes consist of below configuration: HT20/HT40: IEEE 802.11n

3.2. Accessories

N/A

3.3. Table for Filed Antenna

Set	Ant.	Brand	Model Name	Antenna Type	Connector	Gain (dBi)				
						2.4G	5G B1	5G B2	5G B3	5G B4
1	1	MAG.LAYERS	PCA-4077-25GC1-A1-RT	WLAN/BT antenna	I-PEX A13	3.33	5.85	5.85	6.21	6.21
	2	MAG.LAYERS	PCA-4077-25GC1-A1-RT	WLAN/BT antenna	I-PEX A13	3.33	5.85	5.85	6.21	6.21

Note: The each set has two antennas.

For 2.4GHz:

For IEEE 802.11b mode (1TX/1RX)

Only Chain 1 can be used as transmitting/receiving antenna.

For IEEE 802.11g/n mode (2TX/2RX)

Chain 1 and Chain 2 can be used as transmitting/receiving antenna.

Chain 1 and Chain 2 could transmit/receive simultaneously.

For 5GHz:

For IEEE 802.11a/n mode (2TX/2RX)

Chain 1 and Chain 2 can be used as transmitting/receiving antenna.

Chain 1 and Chain 2 could transmit/receive simultaneously.

For Bluetooth mode (1TX/1RX)

Only Chain 2 can be used as transmitting/receiving antenna.

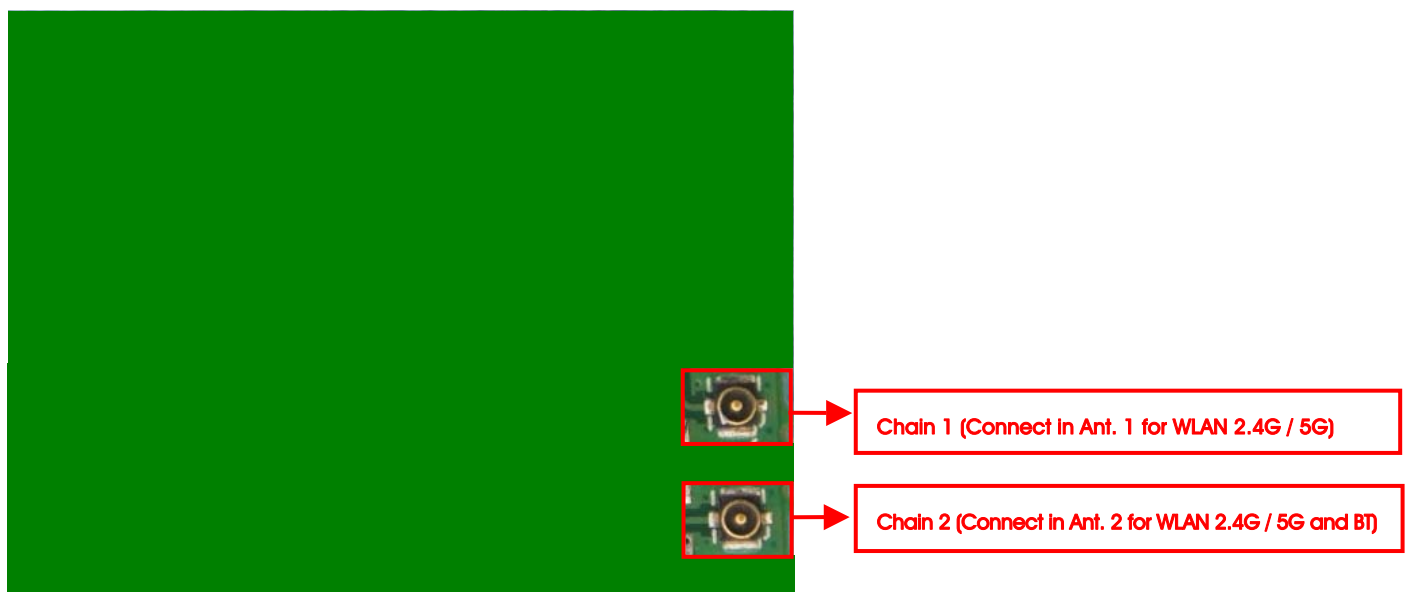

3.4. Table for Carrier Frequencies

There are three bandwidth systems.

For 20MHz bandwidth systems, use Channel 36, 40, 44, 48, 52, 56, 60, 64, 100, 104, 108, 112, 116, 120, 124, 128, 132, 136, 140, 149, 153, 157, 161, 165.

For 40MHz bandwidth systems, use Channel 38, 46, 54, 62, 102, 110, 118, 126, 134, 151, 159.

Frequency Band	Channel No.	Frequency	Channel No.	Frequency
5150~5250 MHz Band 1	36	5180 MHz	44	5220 MHz
	38	5190 MHz	46	5230 MHz
	40	5200 MHz	48	5240 MHz
5250~5350 MHz Band 2	52	5260 MHz	60	5300 MHz
	54	5270 MHz	62	5310 MHz
	56	5280 MHz	64	5320 MHz
5470~5725 MHz Band 3	100	5500 MHz	120	5600 MHz
	102	5510 MHz	124	5620 MHz
	104	5520 MHz	126	5630 MHz
	106	5530 MHz	128	5640 MHz
	108	5540 MHz	132	5660 MHz
	110	5550 MHz	134	5670 MHz
	112	5560 MHz	136	5680 MHz
5725~5850 MHz Band 4	149	5745 MHz	159	5795 MHz
	151	5755 MHz	161	5805 MHz
	153	5765 MHz	165	5825 MHz
	157	5785 MHz	-	-

3.5. Table for Test Modes

Preliminary tests were performed in different data rate to find the worst radiated emission. The data rate shown in the table below is the worst-case rate with respect to the specific test item. Investigation has been done on all the possible configurations for searching the worst cases. The following table is a list of the test modes shown in this test report.

Test Items	Mode		Data Rate	Channel	Chain
Max. Conducted Output Power	11a/BPSK	Band 4	6Mbps	149/157/165	1+2
	11n HT20	Band 4	MCS0	149/157/165	1+2
	11n HT40	Band 4	MCS0	151/159	1+2
Power Spectral Density	11a/BPSK	Band 4	6Mbps	149/157/165	1+2
	11n HT20	Band 4	MCS0	149/157/165	1+2
	11n HT40	Band 4	MCS0	151/159	1+2
26dB Spectrum Bandwidth & 99% Occupied Bandwidth Measurement	11a/BPSK	Band 4	6Mbps	149/157/165	1, 2
	11n HT20	Band 4	MCS0	149/157/165	1, 2
	11n HT40	Band 4	MCS0	151/159	1, 2
6dB Spectrum Bandwidth Measurement	11a/BPSK	Band 4	6Mbps	149/157/165	1, 2
	11n HT20	Band 4	MCS0	149/157/165	1, 2
	11n HT40	Band 4	MCS0	151/159	1, 2
Radiated Emission Above 1GHz	11a/BPSK	Band 4	6Mbps	149/157/165	1+2
	11n HT20	Band 4	MCS0	149/157/165	1+2
	11n HT40	Band 4	MCS0	151/159	1+2
Band Edge Emission	11a/BPSK	Band 4	6Mbps	149/157/165	1+2
	11n HT20	Band 4	MCS0	149/157/165	1+2
	11n HT40	Band 4	MCS0	151/159	1+2
Frequency Stability	20 MHz	Band 4	-	157	1
	40 MHz	Band 4	-	151	1

The following test modes were performed for all tests:

For Radiated Emission Above 1GHz test

Mode 1. CTX-EUT

3.6. Table for Testing Locations

Test Site Location					
Address:	No.8, Lane 724, Bo-ai St., Jhubei City, Hsinchu County 302, Taiwan, R.O.C.				
TEL:	886-3-656-9065				
FAX:	886-3-656-9085				
Test Site No.	Site Category	Location	FCC Reg. No.	IC File No.	VCCI Reg. No
03CH01-CB	SAC	Hsin Chu	262045	IC 4086D	-
TH01-CB	OVEN Room	Hsin Chu	-	-	-

Open Area Test Site (OATS); Semi Anechoic Chamber (SAC).

3.7. Table for Class II Change

This product is an extension of original one reported under Sporton project number: FR440181

Below is the table for the change of the product with respect to the original one.

Modifications	Performance Checking
Updating 5GHz Band 1 to "New Rules" from "Old Rules".	The output power remains the same, so it's no need to re-test.
Updating 5GHz Band 2~3 to "New Rules" from "Old Rules".	After evaluating, it's no need to re-test.
Updating 5GHz Band 4 to "New Rules" from "Old Rules".	<ol style="list-style-type: none"> 1. 26dB Bandwidth and 99% Occupied Bandwidth 2. 6dB Spectrum Bandwidth 3. Maximum Conducted Output Power 4. Power Spectral Density 5. Radiated Emissions above 1GHz (1GHz~40GHz) 6. Band Edge Emissions 7. Frequency Stability
Adding mobile use for the product.	-

3.8. Table for Supporting Units

Support Unit	Brand	Model	FCC ID
NB	DELL	E4300	DoC
Test Fixture	Broadcom	BCM9NGFF2EC_1	N/A

3.9. Table for Parameters of Test Software Setting

During testing, Channel and Power Controlling Software provided by the customer was used to control the operating channel as well as the output power level. The RF output power selection is for the setting of RF output power expected by the customer and is going to be fixed on the firmware of the final end product.

Test Software Version	Mtool 2.0.1.6		
Mode	Test Frequency (MHz)		
	NCB: 20MHz		
	5745 MHz	5785 MHz	5825 MHz
802.11a	55	100	66
802.11n MCS0 HT20	52	100	66
Mode	NCB: 40MHz		
802.11n MCS0 HT40	5755 MHz		5795 MHz
	35	60	

3.10. EUT Operation during Test

The EUT was programmed to be in continuously transmitting mode.

3.11. Duty Cycle

Mode	On Time (ms)	On+Off Time (ms)	Duty Cycle (%)	Duty Factor (dB)	1/T Minimum VBW (kHz)
802.11a	2.058	2.087	98.61	0.06	0.01
802.11n MCS0 HT20	1.900	1.930	98.45	0.07	0.01
802.11n MCS0 HT40	0.932	0.964	96.68	0.15	1.07

3.12. Test Configurations

3.12.1. Radiation Emissions Test Configuration

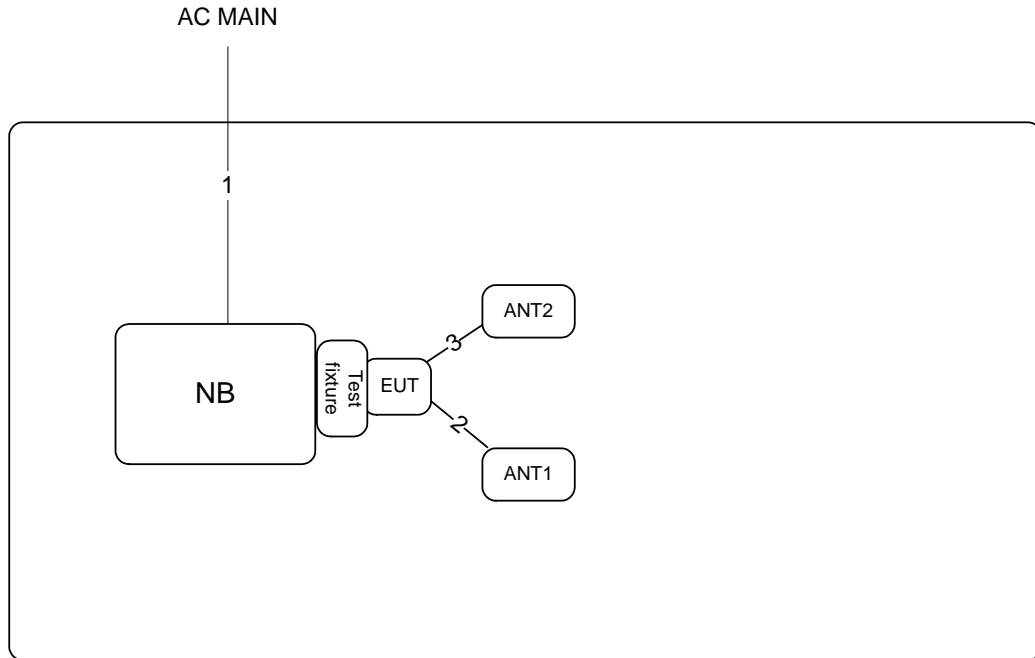

Item	Connection	Shielded	Length(m)
1	Power cable	No	2.6
2	ANT cable	Yes	0.2
3	ANT cable	Yes	0.2

4. TEST RESULT

4.1. 26dB Bandwidth and 99% Occupied Bandwidth Measurement

4.1.1. Limit

No restriction limits.

4.1.2. Measuring Instruments and Setting

Please refer to section 5 of equipments list in this report. The following table is the setting of the spectrum analyzer.

26dB Bandwidth	
Spectrum Parameters	Setting
Attenuation	Auto
Span Frequency	> 26dB Bandwidth
RBW	Approximately 1% of the emission bandwidth
VBW	VBW > RBW
Detector	Peak
Trace	Max Hold
Sweep Time	Auto
99% Occupied Bandwidth	
Spectrum Parameters	Setting
Span	1.5 times to 5.0 times the OBW
RBW	1 % to 5 % of the OBW
VBW	$\geq 3 \times$ RBW
Detector	Peak
Trace	Max Hold

4.1.3. Test Procedures

For Conducted 26dB Bandwidth and 99% Occupied Bandwidth Measurement:

1. The transmitter was radiated to the spectrum analyzer in peak hold mode.
2. Measure the maximum width of the emission that is 26 dB down from the peak of the emission.
3. Compare this with the RBW setting of the analyzer. Readjust RBW and repeat measurement as needed until the RBW/EBW ratio is approximately 1%.
4. Measurement perform conducted of each port.

4.1.4. Test Setup Layout

For Conducted 26dB Bandwidth and 99% Occupied Bandwidth Measurement:

This test setup layout is the same as that shown in section 4.3.4.

4.1.5. Test Deviation

There is no deviation with the original standard.

4.1.6. EUT Operation during Test

The EUT was programmed to be in continuously transmitting mode.

4.1.7. Test Result of 26dB Bandwidth and 99% Occupied Bandwidth

Temperature	25°C	Humidity	45%
Test Engineer	Lucas Huang		

Mode	Frequency	26dB Bandwidth (MHz)		99% Occupied Bandwidth (MHz)	
		Chain 1	Chain 2	Chain 1	Chain 2
802.11a	5745 MHz	22.52	21.57	16.67	16.76
	5785 MHz	46.70	45.57	31.61	31.69
	5825 MHz	24.26	31.74	16.67	17.45
802.11n MCS0 HT20	5745 MHz	23.74	19.57	17.71	17.63
	5785 MHz	54.61	48.61	35.43	33.00
	5825 MHz	39.57	27.04	18.32	17.80
802.11n MCS0 HT40	5755 MHz	40.73	40.73	36.90	36.61
	5795 MHz	92.46	82.17	40.38	37.34

26dB Bandwidth and 99% Occupied Bandwidth Plot on Configuration IEEE 802.11a / Chain 1 / 5745 MHz

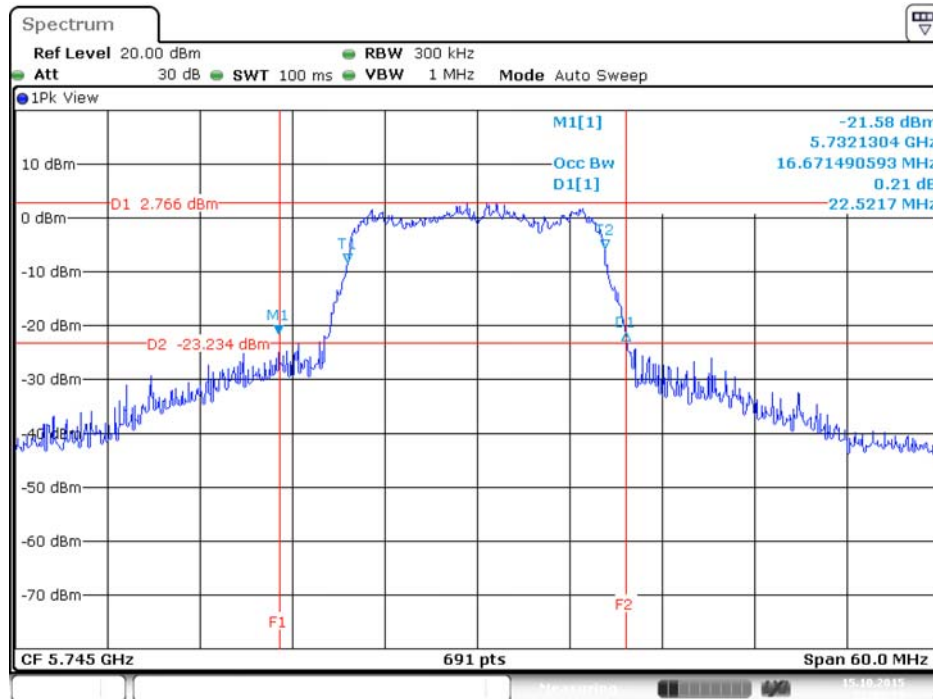

Date: 15.OCT.2015 22:05:40

26dB Bandwidth and 99% Occupied Bandwidth Plot on Configuration IEEE 802.11a / Chain 2 / 5745 MHz

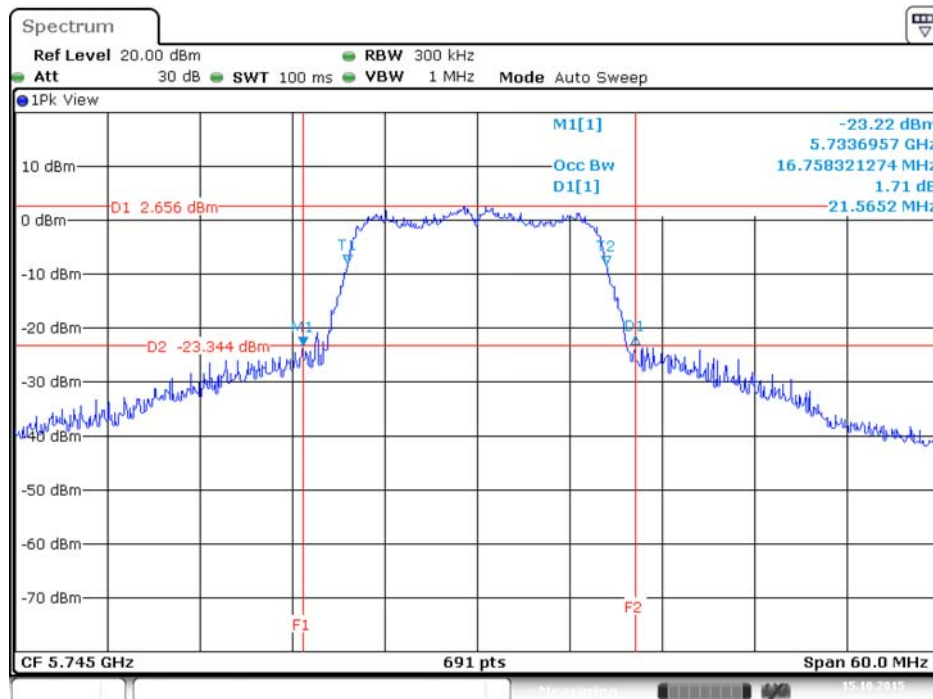

Date: 15.OCT.2015 22:06:25

26dB Bandwidth and 99% Occupied Bandwidth Plot on Configuration IEEE 802.11a / Chain 1 / 5785 MHz

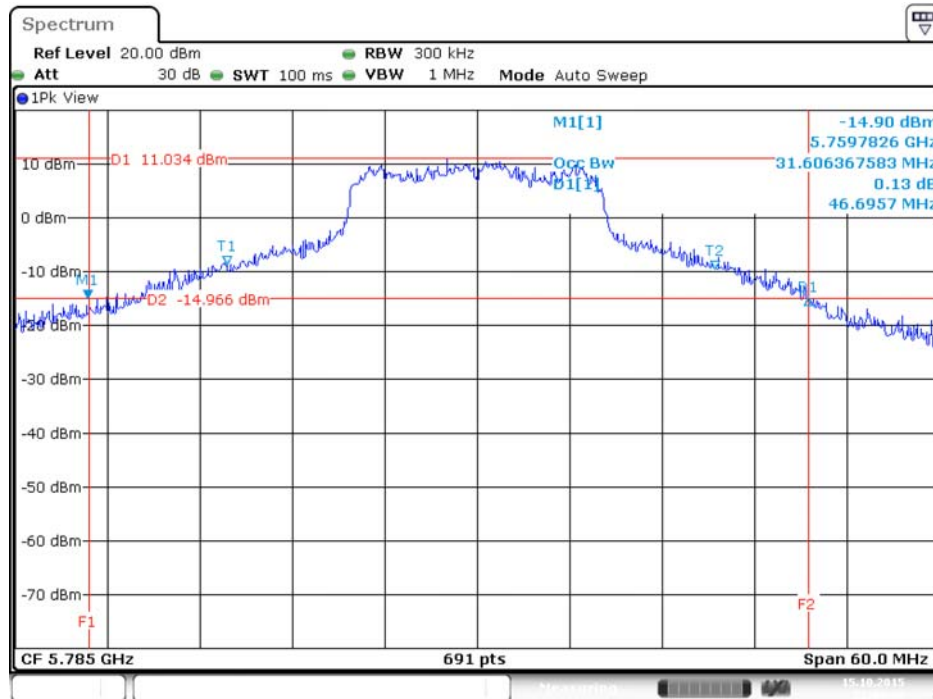

26dB Bandwidth and 99% Occupied Bandwidth Plot on Configuration IEEE 802.11a / Chain 2 / 5785 MHz

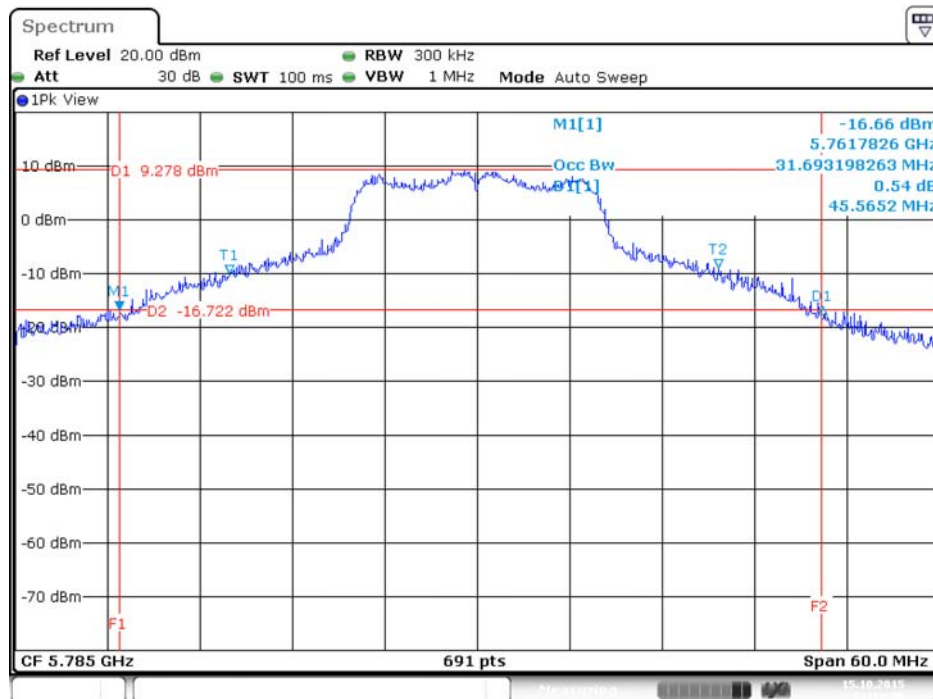

26dB Bandwidth and 99% Occupied Bandwidth Plot on Configuration IEEE 802.11a / Chain 1 / 5825 MHz

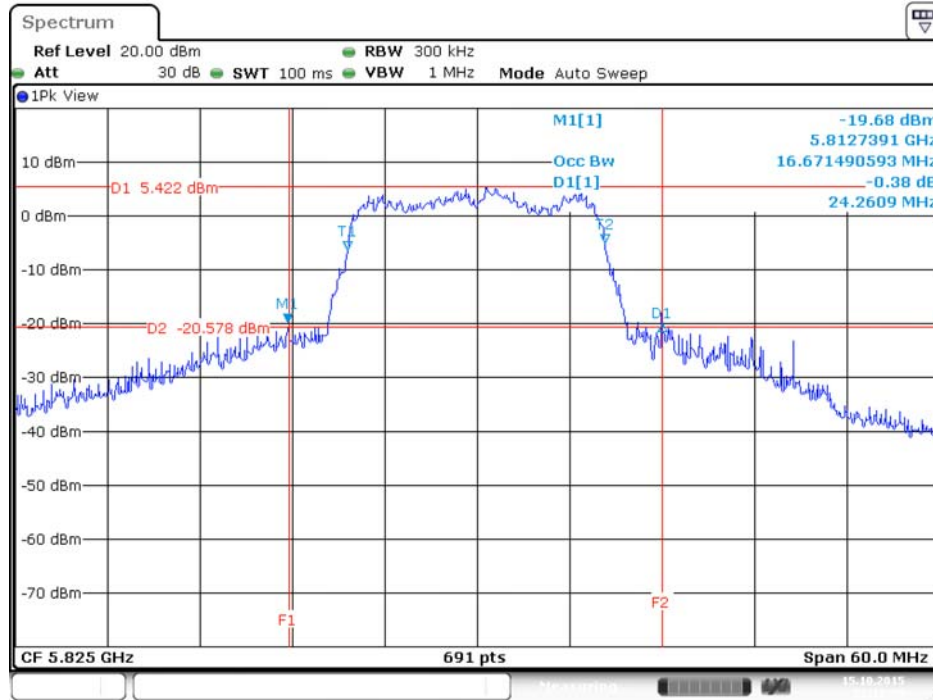

26dB Bandwidth and 99% Occupied Bandwidth Plot on Configuration IEEE 802.11a / Chain 2 / 5825 MHz

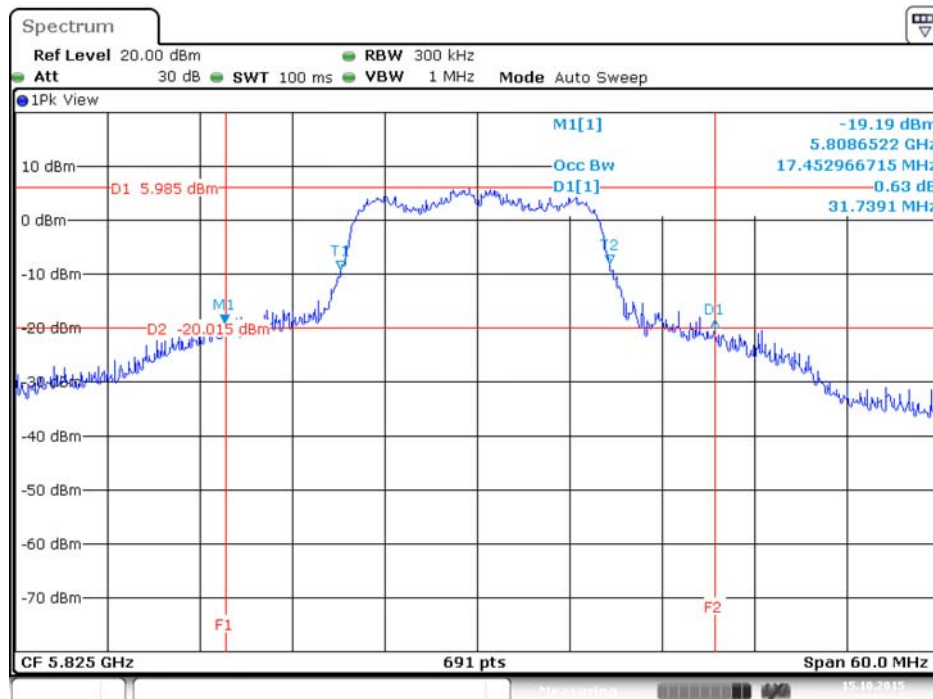

26dB Bandwidth and 99% Occupied Bandwidth Plot on Configuration IEEE 802.11n MCS0 HT20 / Chain 1 / 5745 MHz

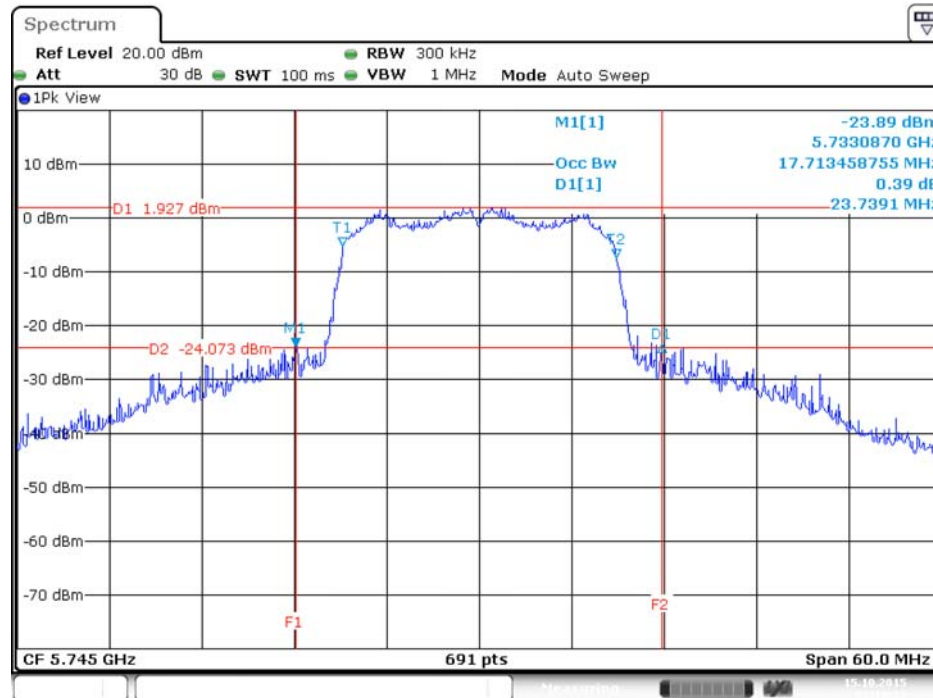

Date: 15.OCT.2015 22:15:23

26dB Bandwidth and 99% Occupied Bandwidth Plot on Configuration IEEE 802.11n MCS0 HT20 / Chain 2 / 5745 MHz

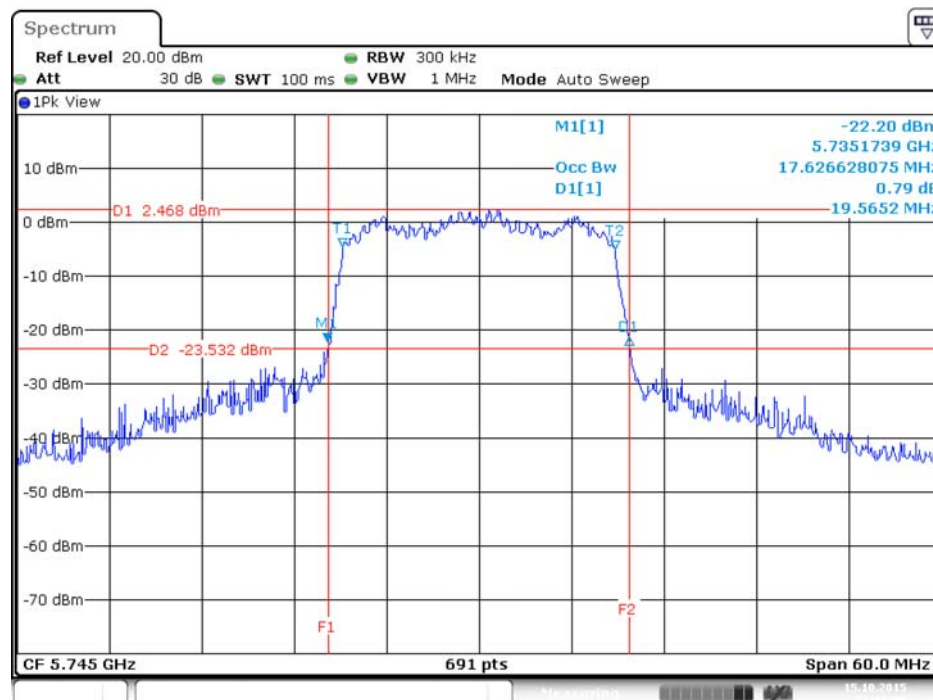

Date: 15.OCT.2015 22:16:29

26dB Bandwidth and 99% Occupied Bandwidth Plot on Configuration IEEE 802.11n MCS0 HT20 / Chain 1 / 5785 MHz

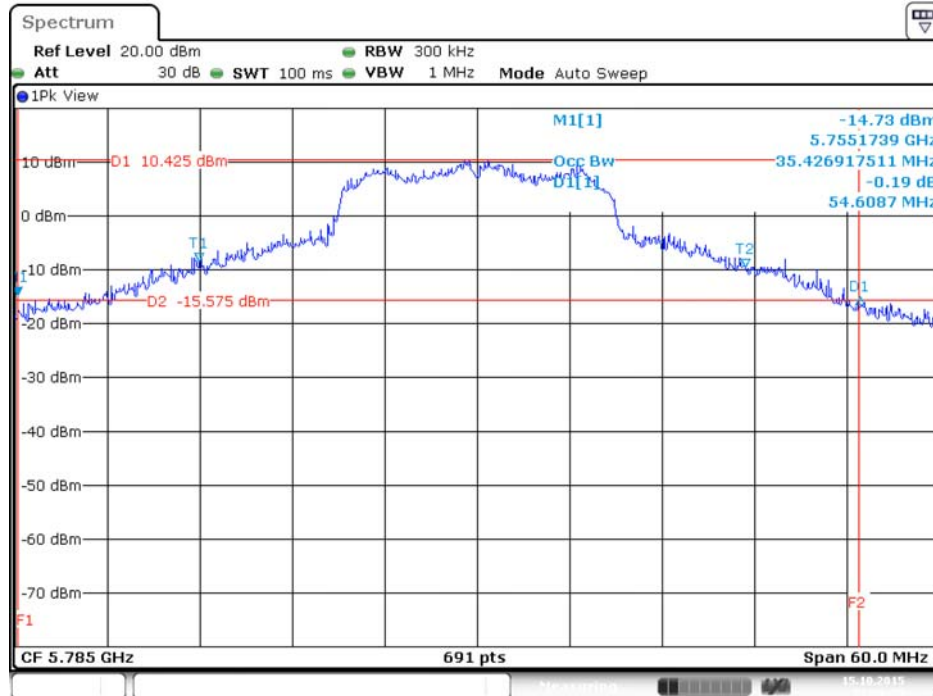

Date: 15.OCT.2015 22:26:24

26dB Bandwidth and 99% Occupied Bandwidth Plot on Configuration IEEE 802.11n MCS0 HT20 / Chain 2 / 5785 MHz

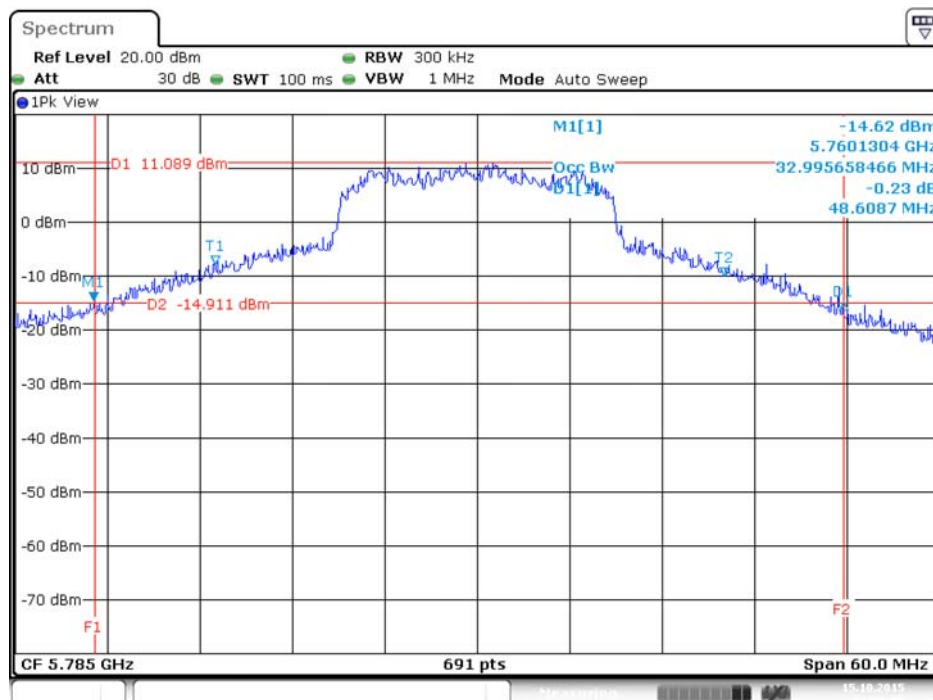

Date: 15.OCT.2015 22:26:55

26dB Bandwidth and 99% Occupied Bandwidth Plot on Configuration IEEE 802.11n MCS0 HT20 / Chain 1 / 5825 MHz

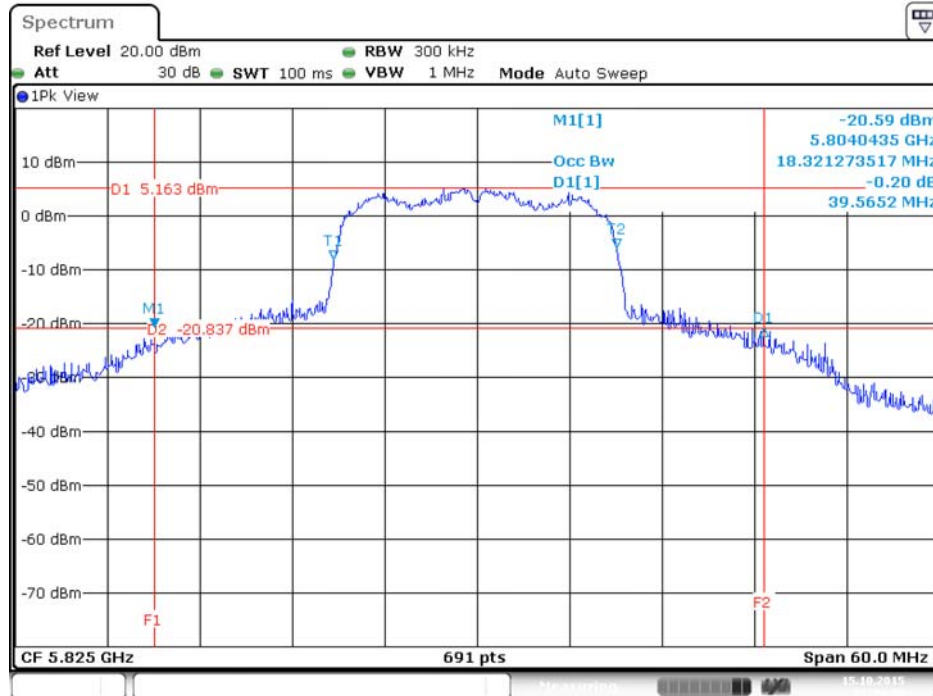

Date: 15.OCT.2015 22:29:09

26dB Bandwidth and 99% Occupied Bandwidth Plot on Configuration IEEE 802.11n MCS0 HT20 / Chain 2 / 5825 MHz

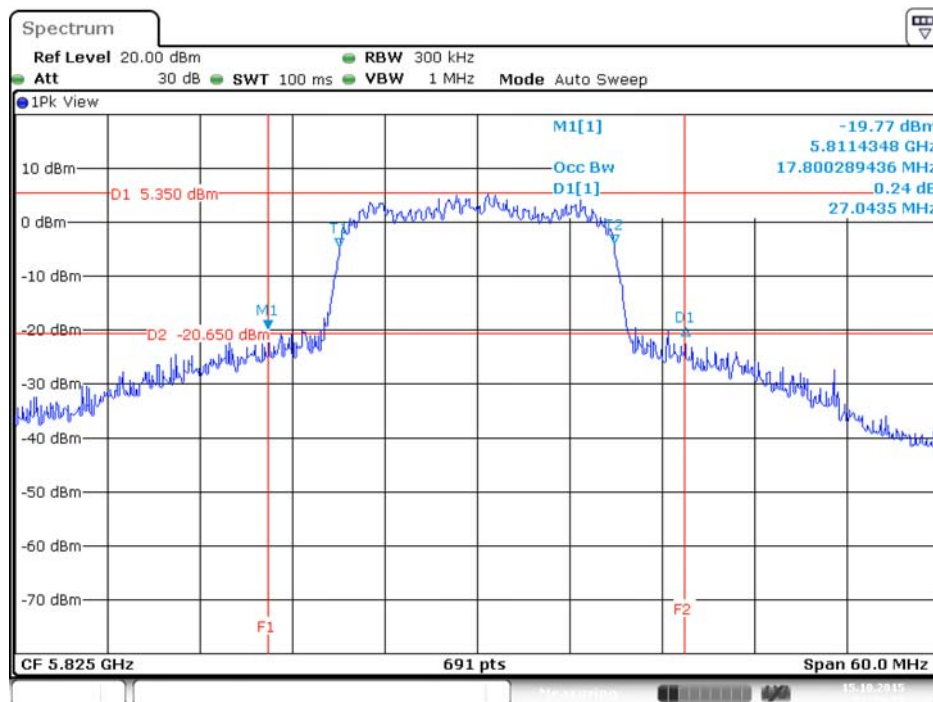

Date: 15.OCT.2015 22:29:34

26dB Bandwidth and 99% Occupied Bandwidth Plot on Configuration IEEE 802.11n MCS0 HT40 / Chain 1 / 5755 MHz

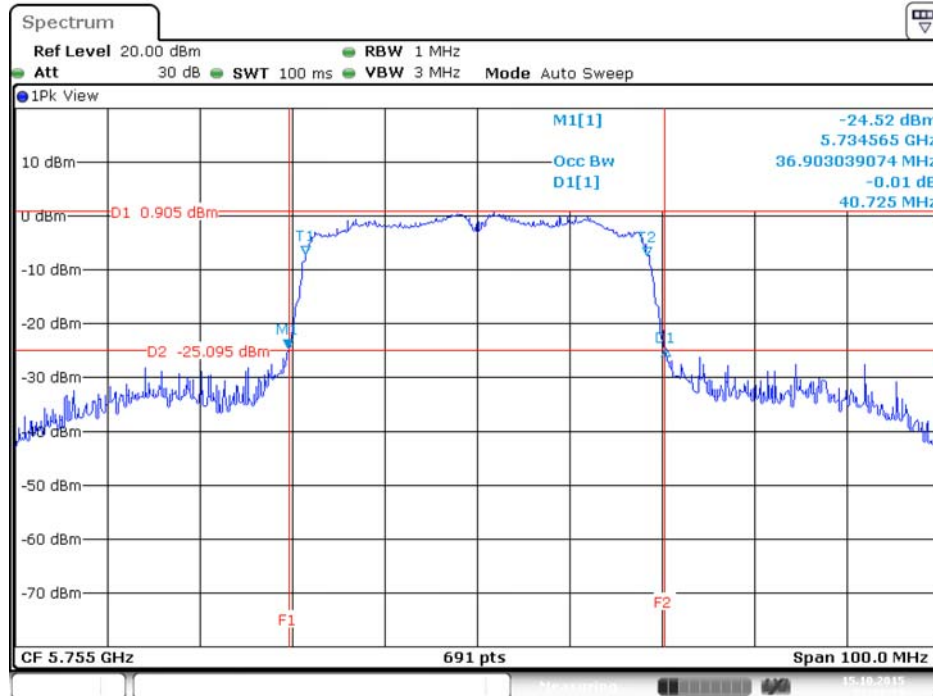

Date: 15.OCT.2015 22:32:40

26dB Bandwidth and 99% Occupied Bandwidth Plot on Configuration IEEE 802.11n MCS0 HT40 / Chain 2 / 5755 MHz

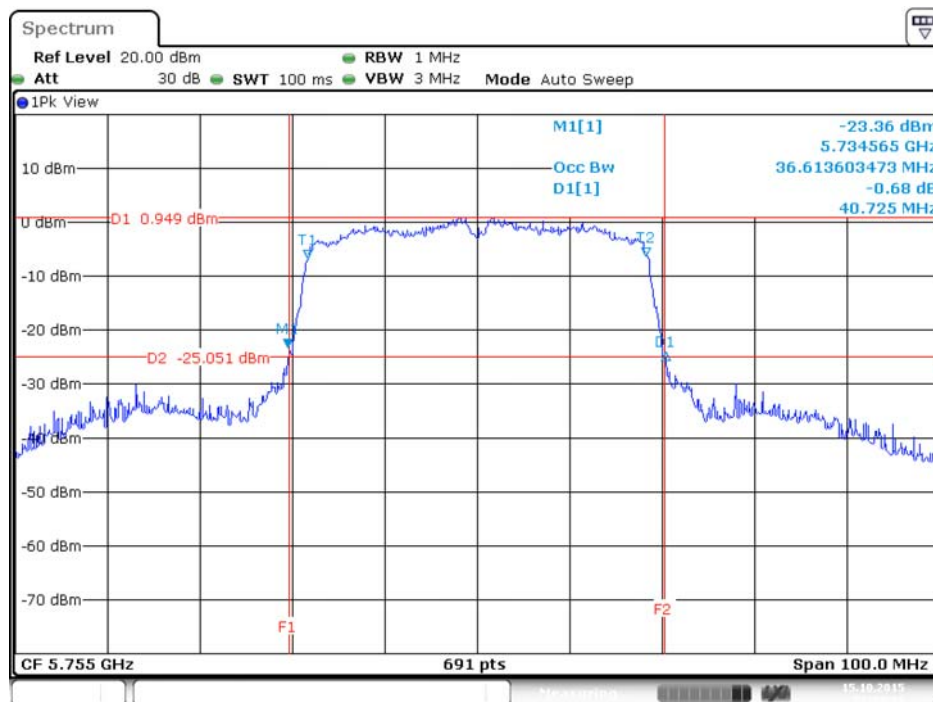

Date: 15.OCT.2015 22:33:11

26dB Bandwidth and 99% Occupied Bandwidth Plot on Configuration IEEE 802.11n MCS0 HT40 / Chain 1 / 5795 MHz

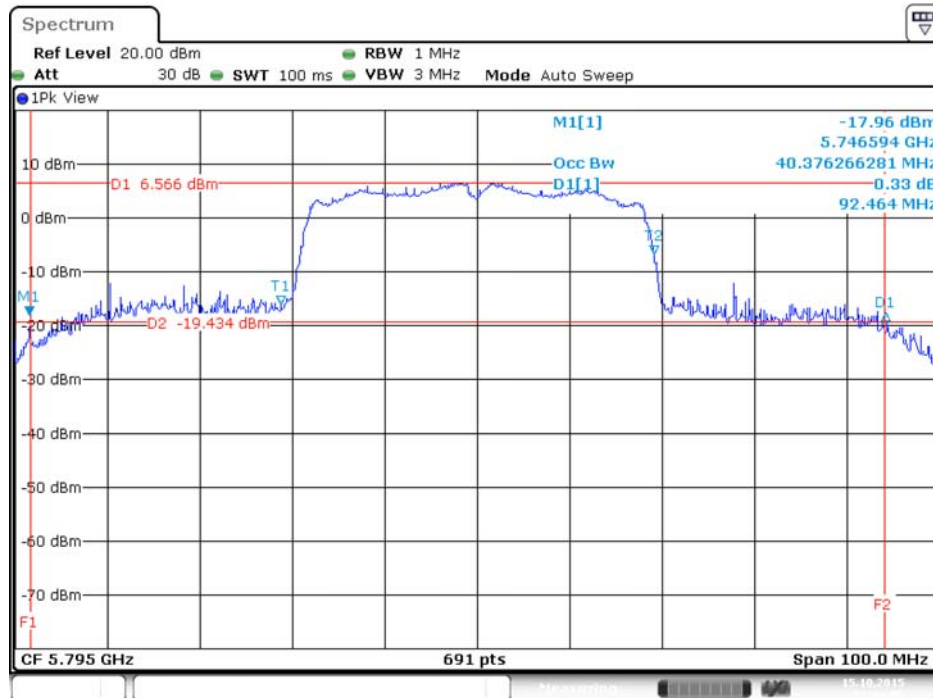

Date: 15.OCT.2015 22:34:57

26dB Bandwidth and 99% Occupied Bandwidth Plot on Configuration IEEE 802.11n MCS0 HT40 / Chain 2 / 5795 MHz

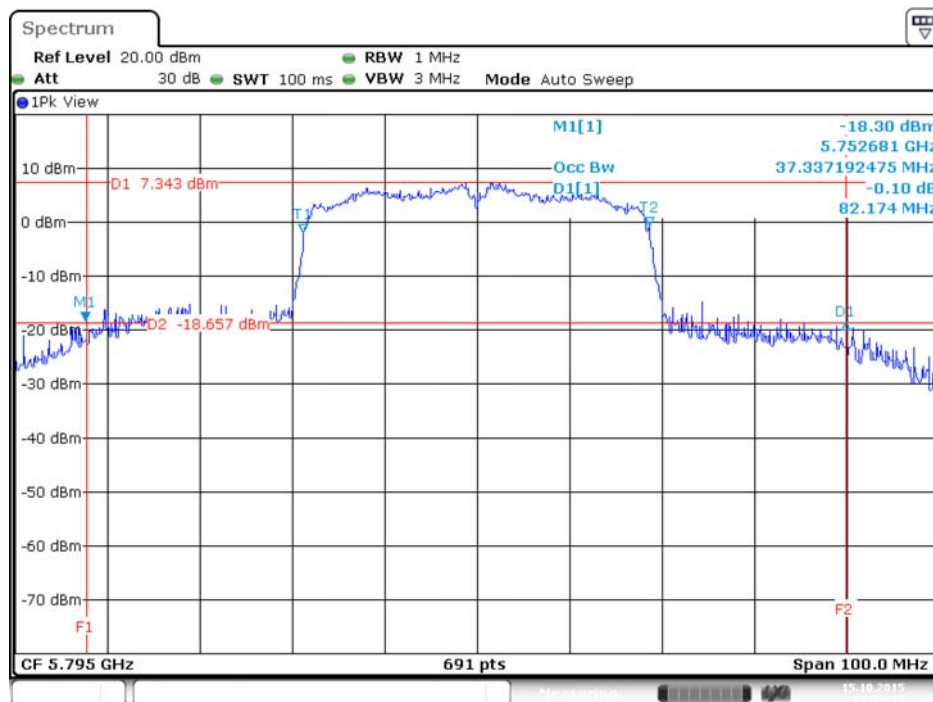

Date: 15.OCT.2015 22:35:22

4.2. 6dB Spectrum Bandwidth Measurement

4.2.1. Limit

For digital modulation systems, the minimum 6dB bandwidth shall be at least 500 kHz.

4.2.2. Measuring Instruments and Setting

Please refer to section 5 of equipments list in this report. The following table is the setting of spectrum analyzer.

6dB Spectrum Bandwidth	
Spectrum Parameters	Setting
Attenuation	Auto
Span Frequency	> 6dB Bandwidth
RBW	100kHz
VBW	$\geq 3 \times \text{RBW}$
Detector	Peak
Trace	Max Hold
Sweep Time	Auto

4.2.3. Test Procedures

For Conducted 6dB Bandwidth Measurement:

1. The transmitter was conducted to the spectrum analyzer in peak hold mode.
2. Test was performed in accordance with KDB789033 D02 v01 for Compliance Testing of Unlicensed National Information Infrastructure (U-NII) Devices - section (C) Emission Bandwidth.
3. Multiple antenna system was performed in accordance with KDB662911 D01 v02r01 Emissions Testing of Transmitters with Multiple Outputs in the Same Band.
4. Measurement perform conducted of each port.
5. Measured the spectrum width with power higher than 6dB below carrier.

4.2.4. Test Setup Layout

For Conducted 6dB Bandwidth Measurement:

This test setup layout is the same as that shown in section 4.3.4.

4.2.5. Test Deviation

There is no deviation with the original standard.

4.2.6. EUT Operation during Test

The EUT was programmed to be in continuously transmitting mode.

4.2.7. Test Result of 6dB Spectrum Bandwidth

Temperature	25°C	Humidity	45%
Test Engineer	Lucas Huang		

Mode	Frequency	6dB Bandwidth (MHz)		Min. Limit (kHz)	Test Result
		Chain 1	Chain 2		
802.11a	5745 MHz	15.13	15.07	500	Complies
	5785 MHz	15.13	14.90	500	Complies
	5825 MHz	16.00	15.07	500	Complies
802.11n MCS0 HT20	5745 MHz	15.07	15.36	500	Complies
	5785 MHz	15.65	14.43	500	Complies
	5825 MHz	15.07	15.54	500	Complies
802.11n MCS0 HT40	5755 MHz	36.06	35.59	500	Complies
	5795 MHz	36.29	36.29	500	Complies

Note: All the test values were listed in the report.

For plots, only the channel with worse result was shown.

6 dB Bandwidth Plot on Configuration IEEE 802.11a / Chain 1 / 5785 MHz

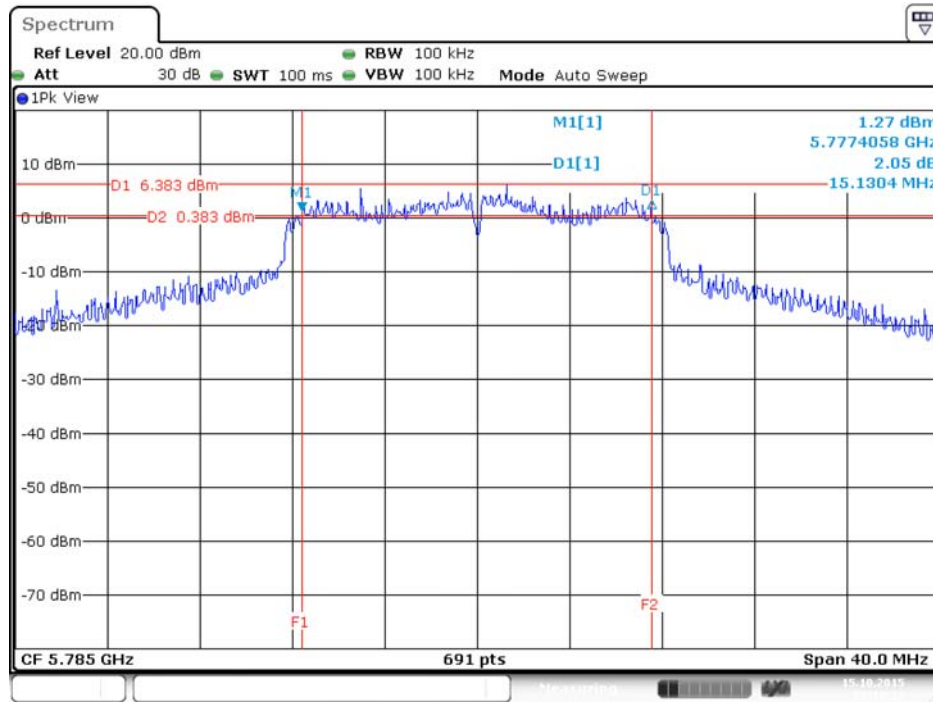

6 dB Bandwidth Plot on Configuration IEEE 802.11a / Chain 2 / 5785 MHz

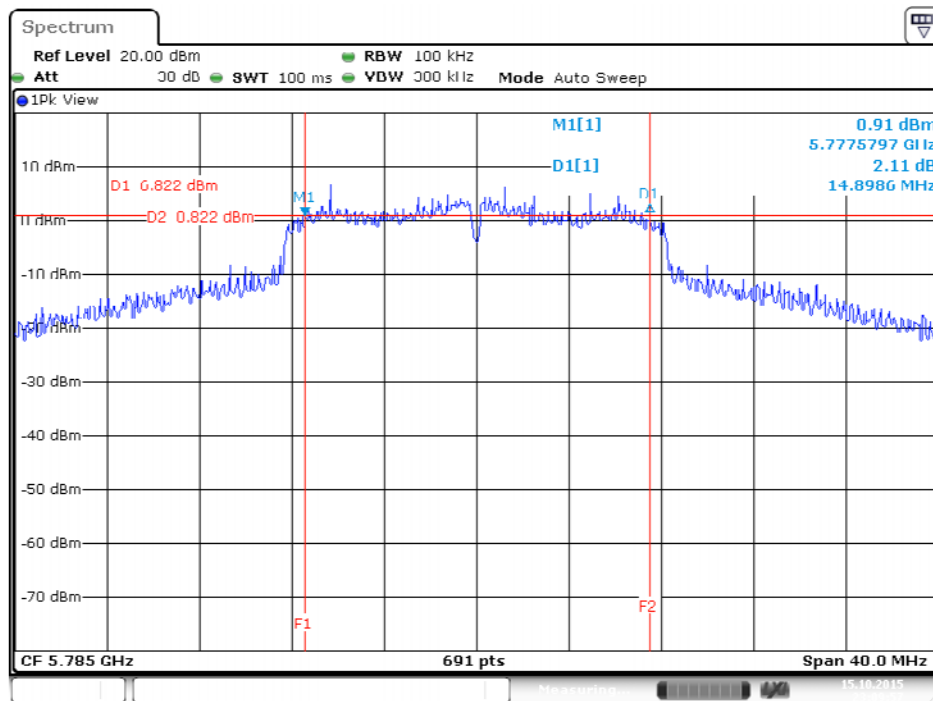

6 dB Bandwidth Plot on Configuration IEEE 802.11n MCS0 HT20 / Chain 1 / 5745 MHz

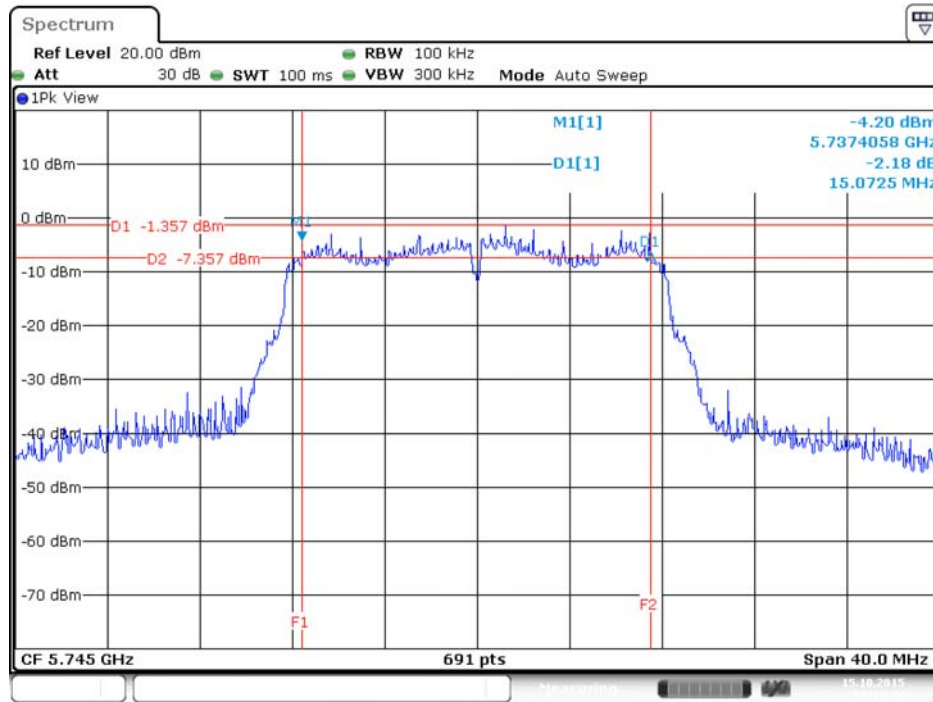

Date: 15.OCT.2015 23:13:43

6 dB Bandwidth Plot on Configuration IEEE 802.11n MCS0 HT20 / Chain 2 / 5785 MHz

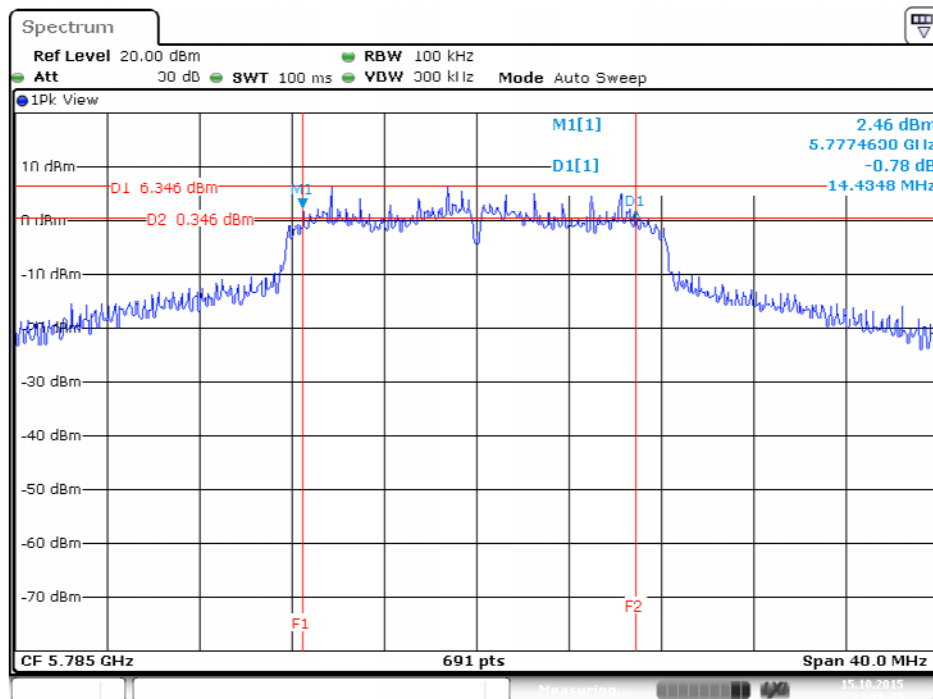

Date: 15.OCT.2015 23:16:26

6 dB Bandwidth Plot on Configuration IEEE 802.11n MCS0 HT40 / Chain 1 / 5755MHz

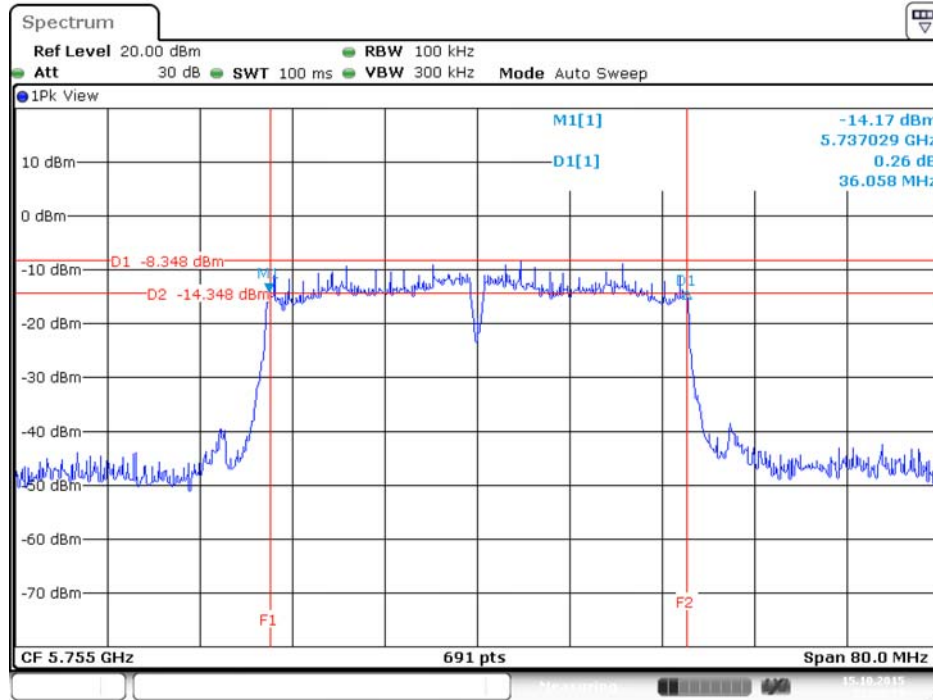

6 dB Bandwidth Plot on Configuration IEEE 802.11n MCS0 HT40 / Chain 2 / 5755MHz

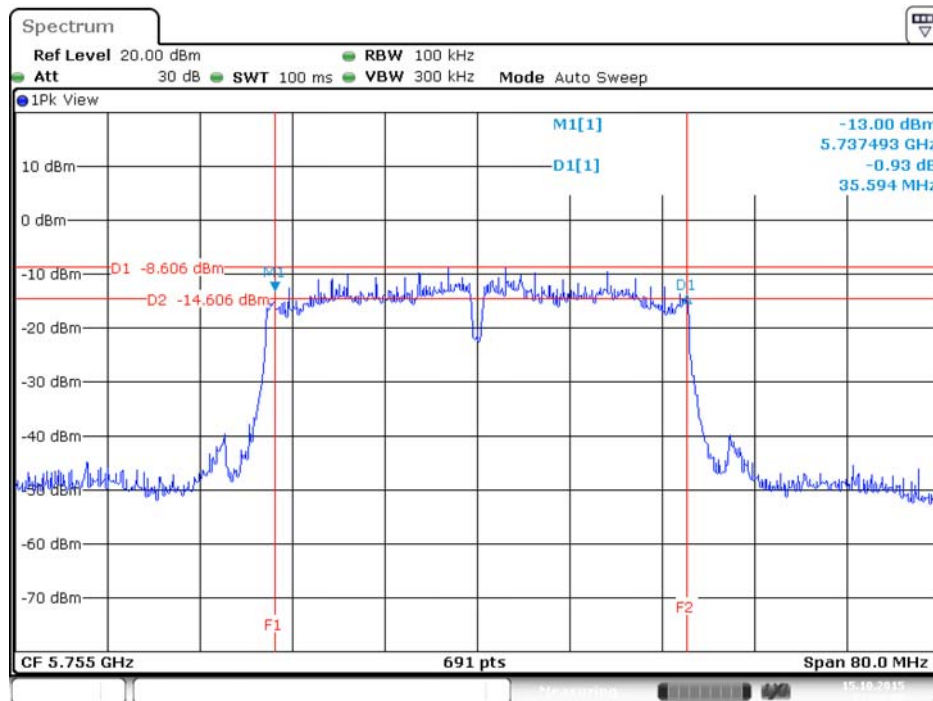

4.3. Maximum Conducted Output Power Measurement

4.3.1. Limit

Frequency Band	Limit
<input checked="" type="checkbox"/> 5.725~5.85 GHz	The maximum conducted output power over the frequency band of operation shall not exceed 1 W (30dBm). If transmitting antennas of directional gain greater than 6 dBi are used, both the maximum conducted output power and the maximum power spectral density shall be reduced by the amount in dB that the directional gain of the antenna exceeds 6 dBi. However, fixed point-to-point U-NII devices operating in this band may employ transmitting antennas with directional gain greater than 6 dBi without any corresponding reduction in transmitter conducted power.

4.3.2. Measuring Instruments and Setting

Please refer to section 5 of equipments list in this report. The following table is the setting of the power meter.

Power Meter Parameter	Setting
Bandwidth	50MHz bandwidth is greater than the EUT emission bandwidth
Detector	AVERAGE

4.3.3. Test Procedures

1. The transmitter output (antenna port) was connected to the power meter.
2. Test was performed in accordance with KDB789033 D02 v01 for Compliance Testing of Unlicensed National Information Infrastructure (U-NII) Devices - section (E) Maximum conducted output power =>3. Measurement using a Power Meter (PM) =>b) Method PM-G (Measurement using a gated RF average power meter).
3. Multiple antenna systems was performed in accordance with KDB662911 D01 v02r01 Emissions Testing of Transmitters with Multiple Outputs in the Same Band.
4. When measuring maximum conducted output power with multiple antenna systems, add every result of the values by mathematic formula.

4.3.4. Test Setup Layout

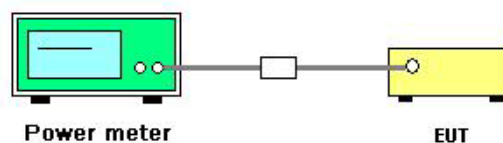

4.3.5. Test Deviation

There is no deviation with the original standard.

4.3.6. EUT Operation during Test

The EUT was programmed to be in continuously transmitting mode.

4.3.7. Test Result of Maximum Conducted Output Power

Temperature	25°C	Humidity	45%
Test Engineer	Lucas Huang	Test Date	Oct. 13, 2015

Mode	Frequency	Conducted Power (dBm)			Max. Limit (dBm)	Result
		Chain 1	Chain 2	Total		
802.11a	5745 MHz	14.71	14.48	17.61	29.79	Complies
	5785 MHz	20.25	21.43	23.89	29.79	Complies
	5825 MHz	16.72	16.02	19.39	29.79	Complies
802.11n MCS0 HT20	5745 MHz	13.94	13.62	16.79	29.79	Complies
	5785 MHz	20.12	20.86	23.52	29.79	Complies
	5825 MHz	16.82	15.85	19.37	29.79	Complies
802.11n MCS0 HT40	5755 MHz	10.05	9.15	12.63	29.79	Complies
	5795 MHz	15.28	14.92	18.11	29.79	Complies

Note: Antenna gain=6.21dBi > 6dBi, So Limit =30-(6.21-6)=29.79dBm

Only for power table of SAR

Configuration IEEE 802.11a / Chain 1 + Chain 2

Channel	Frequency	Duty Factor	Total Conducted Power (dBm)	Max. Limit (dBm)	Result
149	5745 MHz	0.06	16.18	30.00	Complies
153	5765 MHz		16.15	30.00	Complies
157	5785 MHz		16.22	30.00	Complies
161	5805 MHz		16.20	30.00	Complies
165	5825 MHz		16.16	30.00	Complies

Configuration IEEE 802.11n MCS0 HT20 / Chain 1 + Chain 2

Channel	Frequency	Duty Factor	Total Conducted Power (dBm)	Max. Limit (dBm)	Result
149	5745 MHz	0.07	16.23	30.00	Complies
153	5765 MHz		16.24	30.00	Complies
157	5785 MHz		16.23	30.00	Complies
161	5805 MHz		16.26	30.00	Complies
165	5825 MHz		16.28	30.00	Complies

Configuration IEEE 802.11n MCS0 HT40 / Chain 1 + Chain 2

Channel	Frequency	Duty Factor	Total Conducted Power (dBm)	Max. Limit (dBm)	Result
151	5755 MHz	0.09	16.21	30.00	Complies
159	5795 MHz		16.15	30.00	Complies

4.4. Power Spectral Density Measurement

4.4.1. Limit

The following table is power spectral density limits and decrease power density limit rule refer to section 4.3.1.

	Frequency Band	Limit
<input checked="" type="checkbox"/>	5.725~5.85 GHz	30 dBm/500kHz

4.4.2. Measuring Instruments and Setting

Please refer to section 5 of equipments list in this report. The following table is the setting of the spectrum analyzer.

Spectrum Parameter	Setting
Attenuation	Auto
Span Frequency	Encompass the entire emissions bandwidth (EBW) of the signal
RBW	1000 kHz
VBW	3000 kHz
Detector	RMS
Trace	AVERAGE
Sweep Time	Auto
Trace Average	100 times
Note: If measurement bandwidth of Maximum PSD is specified in 500 kHz, add $10\log(500\text{kHz}/\text{RBW})$ to the measured result, whereas RBW (< 500 kHz) is the reduced resolution bandwidth of the spectrum analyzer set during measurement.	

4.4.3. Test Procedures

1. The transmitter output (antenna port) was connected RF switch to the spectrum analyzer.
2. Test was performed in accordance with KDB789033 D02 v01 for Compliance Testing of Unlicensed National Information Infrastructure (U-NII) Devices - section (F) Maximum Power Spectral Density (PSD).
3. Multiple antenna systems was performed in accordance KDB662911 D01 v02r01 in-Band Power Spectral Density (PSD) Measurements (a) Measure and sum the spectra across the outputs.
4. When measuring first spectral bin of output 1 is summed with that in the first spectral bin of output 2 and that from the first spectral bin of output 3 and so on up to the Nth output to obtain the value for the first frequency bin of the summed spectrum. The summed spectrum value for each of the other frequency bins is computed in the same way.
5. For 5.725~5.85 GHz, the measured result of PSD level must add $10\log(500\text{kHz}/\text{RBW})$ and the final result should ≤ 30 dBm.

4.4.4. Test Setup Layout

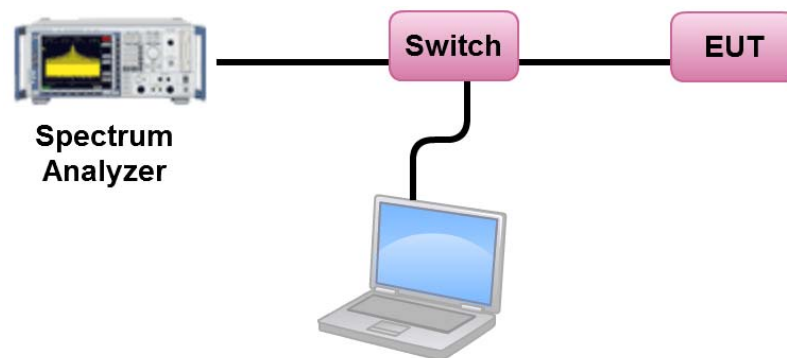

4.4.5. Test Deviation

There is no deviation with the original standard.

4.4.6. EUT Operation during Test

The EUT was programmed to be in continuously transmitting mode.

4.4.7. Test Result of Power Spectral Density

Temperature	25°C	Humidity	45%
Test Engineer	Lucas Huang	Test Date	Oct. 13, 2015

Configuration IEEE 802.11a / Chain 1 + Chain 2

Channel	Frequency	Power Density (dBm/MHz)	10log(500kHz/RBW) Factor (dB)	Power Density (dBm/500kHz)	Power Density Limit (dBm/500kHz)	Result
149	5745 MHz	4.52	-3.01	1.51	26.78	Complies
157	5785 MHz	10.73	-3.01	7.72	26.78	Complies
165	5825 MHz	6.29	-3.01	3.28	26.78	Complies

$$\text{Note: } \textit{DirectionalGain} = 10 \cdot \log \left[\frac{\sum_{j=1}^{N_{SS}} \left\{ \sum_{k=1}^{N_{ANT}} g_{j,k} \right\}^2}{N_{ANT}} \right] = 9.22\text{dBi} > 6\text{dBi}, \text{So Limit} = 30 - (9.22 - 6) = 26.78\text{dBm}/500\text{kHz}$$

Configuration IEEE 802.11n MCS0 HT20 / Chain 1 + Chain 2

Channel	Frequency	Power Density (dBm/MHz)	10log(500kHz/RBW) Factor (dB)	Power Density (dBm/500kHz)	Power Density Limit (dBm/500kHz)	Result
149	5745 MHz	3.67	-3.01	0.66	26.78	Complies
157	5785 MHz	10.36	-3.01	7.35	26.78	Complies
165	5825 MHz	6.33	-3.01	3.32	26.78	Complies

$$\text{Note: } \textit{DirectionalGain} = 10 \cdot \log \left[\frac{\sum_{j=1}^{N_{SS}} \left\{ \sum_{k=1}^{N_{ANT}} g_{j,k} \right\}^2}{N_{ANT}} \right] = 9.22\text{dBi} > 6\text{dBi}, \text{So Limit} = 30 - (9.22 - 6) = 26.78\text{dBm}/500\text{kHz}$$

Configuration IEEE 802.11n MCS0 HT40 / Chain 1 + Chain 2

Channel	Frequency	Power Density (dBm/MHz)	10log(500kHz/RBW) Factor (dB)	Power Density (dBm/500kHz)	Power Density Limit (dBm/500kHz)	Result
151	5755 MHz	-3.46	-3.01	-6.47	26.78	Complies
159	5795 MHz	2.01	-3.01	-1.00	26.78	Complies

Note: $DirectionalGain = 10 \cdot \log \left[\frac{\sum_{j=1}^{N_{SS}} \left\{ \sum_{k=1}^{N_{ANT}} g_{j,k} \right\}^2}{N_{ANT}} \right] = 9.22\text{dBi} > 6\text{dBi}$, So Limit = $30 - (9.22 - 6) = 26.78\text{dBm}/500\text{kHz}$

Note: All the test values were listed in the report.

For plots, only the channel with worse result was shown.

Power Density Plot on Configuration IEEE 802.11a / Chain 1 + Chain 2 / 5785 MHz

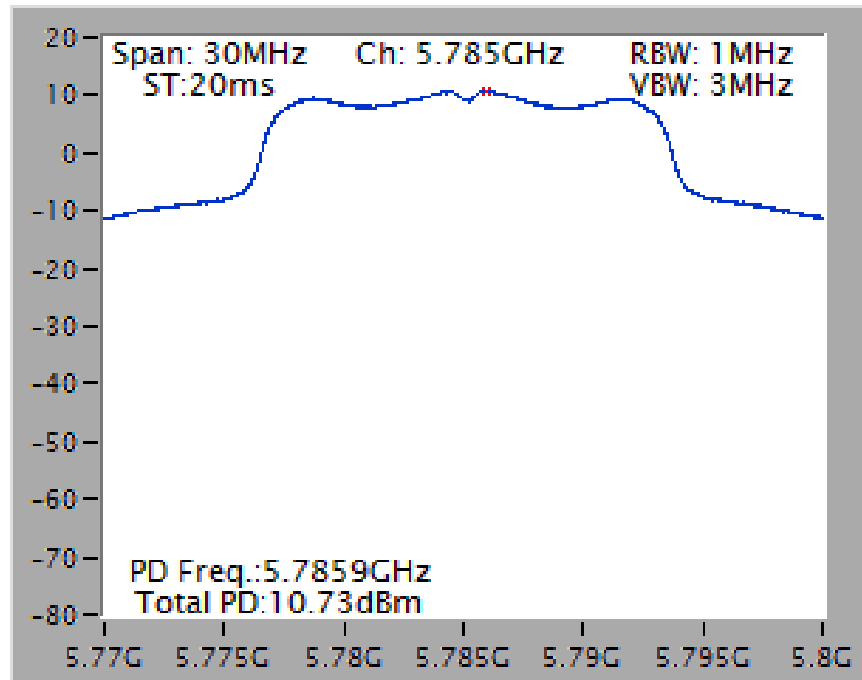

Power Density Plot on Configuration IEEE 802.11n MCS0 HT20 / Chain 1 + Chain 2 / 5785 MHz

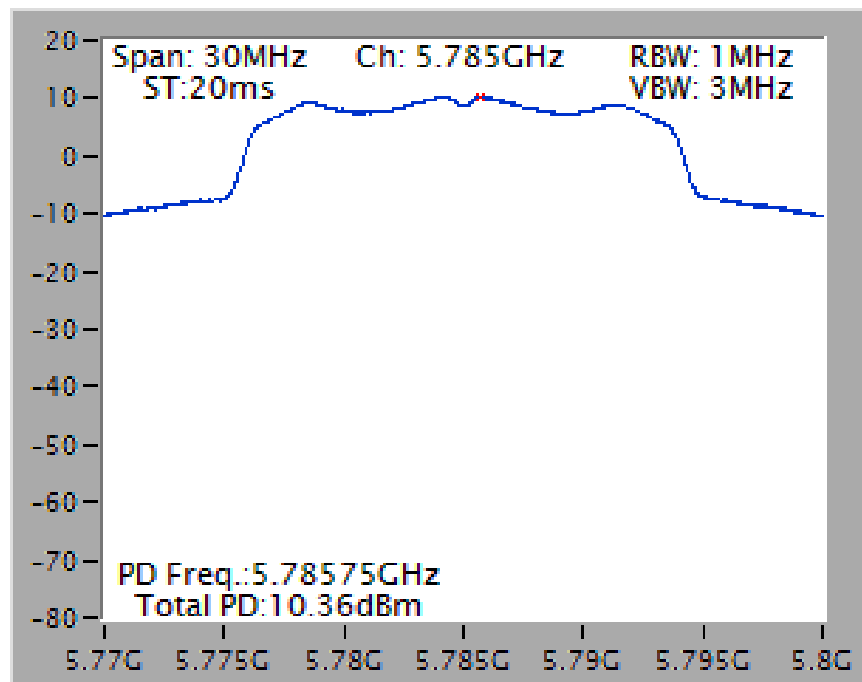

Power Density Plot on Configuration IEEE 802.11n MCS0 HT40 / Chain 1 + Chain 2 / 5795 MHz

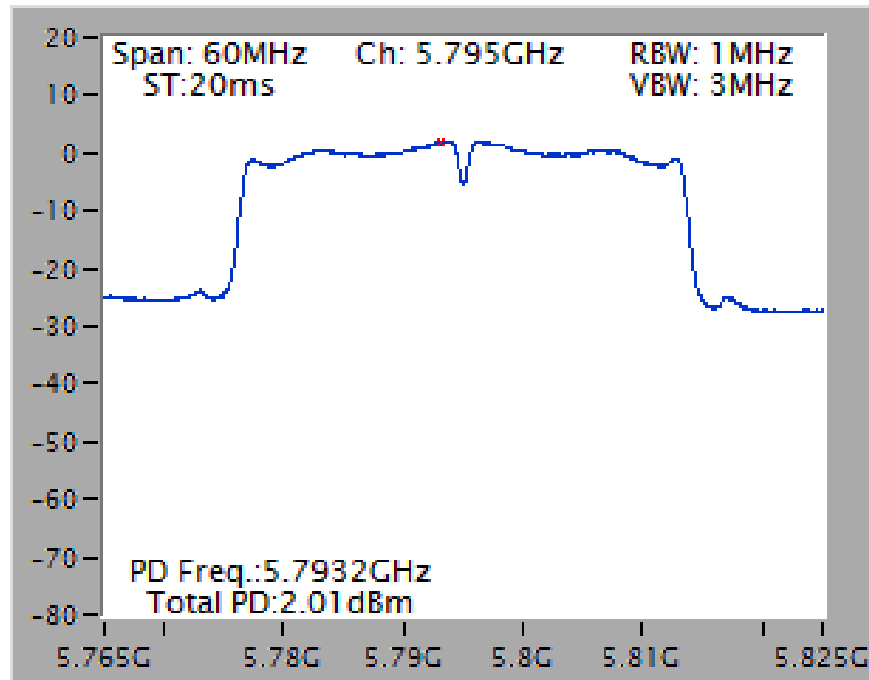

4.5. Radiated Emissions Measurement

4.5.1. Limit

For transmitters operating in the 5.725-5.85 GHz band: all emissions within the frequency range from the band edge to 10 MHz above or below the band edge shall not exceed an e.i.r.p. of -17 dBm/MHz; for frequencies 10 MHz or greater above or below the band edge, emissions shall not exceed an e.i.r.p. of -27 dBm/MHz.

In addition, In case the emission fall within the restricted band specified on 15.205(a), then the 15.209(a) limit in the table below has to be followed.

Frequencies (MHz)	Field Strength (micorvolts/meter)	Measurement Distance (meters)
0.009~0.490	2400/F(kHz)	300
0.490~1.705	24000/F(kHz)	30
1.705~30.0	30	30
30~88	100	3
88~216	150	3
216~960	200	3
Above 960	500	3

4.5.2. Measuring Instruments and Setting

Please refer to section 5 of equipments list in this report. The following table is the setting of spectrum analyzer and receiver.

Spectrum Parameter	Setting
Attenuation	Auto
Start Frequency	1000 MHz
Stop Frequency	40 GHz
RBW / VBW (Emission in restricted band)	1 MHz / 3MHz for Peak, 1 MHz / 1/T for Average
RBW / VBW (Emission in non-restricted band)	1 MHz / 3MHz for peak

Receiver Parameter	Setting
Attenuation	Auto
Start ~ Stop Frequency	9kHz~150kHz / RBW 200Hz for QP
Start ~ Stop Frequency	150kHz~30MHz / RBW 9kHz for QP
Start ~ Stop Frequency	30MHz~1000MHz / RBW 120kHz for QP

4.5.3. Test Procedures

1. Configure the EUT according to ANSI C63.10. The EUT was placed on the top of the turntable 1.5 meter above ground. The phase center of the receiving antenna mounted on the top of a height-variable antenna tower was placed 1m & 3m far away from the turntable.
2. Power on the EUT and all the supporting units. The turntable was rotated by 360 degrees to determine the position of the highest radiation.
3. The height of the broadband receiving antenna was varied between one meter and four meters above ground to find the maximum emissions field strength of both horizontal and vertical polarization.
4. For each suspected emissions, the antenna tower was scan (from 1 M to 4 M) and then the turntable was rotated (from 0 degree to 360 degrees) to find the maximum reading.
5. Set the test-receiver system to Peak or CISPR quasi-peak Detect Function with specified bandwidth under Maximum Hold Mode.
6. For emissions above 1GHz, use 1MHz VBW and 3MHz RBW for peak reading. Then 1MHz RBW and 1/T VBW for average reading in spectrum analyzer.
7. If the emissions level of the EUT in peak mode was 3 dB lower than the average limit specified, then testing will be stopped and peak values of EUT will be reported, otherwise, the emissions which do not have 3 dB margin will be repeated one by one using the quasi-peak method for below 1GHz.
8. For testing above 1GHz, the emissions level of the EUT in peak mode was lower than average limit (that means the emissions level in peak mode also complies with the limit in average mode), then testing will be stopped and peak values of EUT will be reported, otherwise, the emissions will be measured in average mode again and reported.
9. In case the emission is lower than 30MHz, loop antenna has to be used for measurement and the recorded data should be QP measured by receiver. High – Low scan is not required in this case.

4.5.4. Test Setup Layout

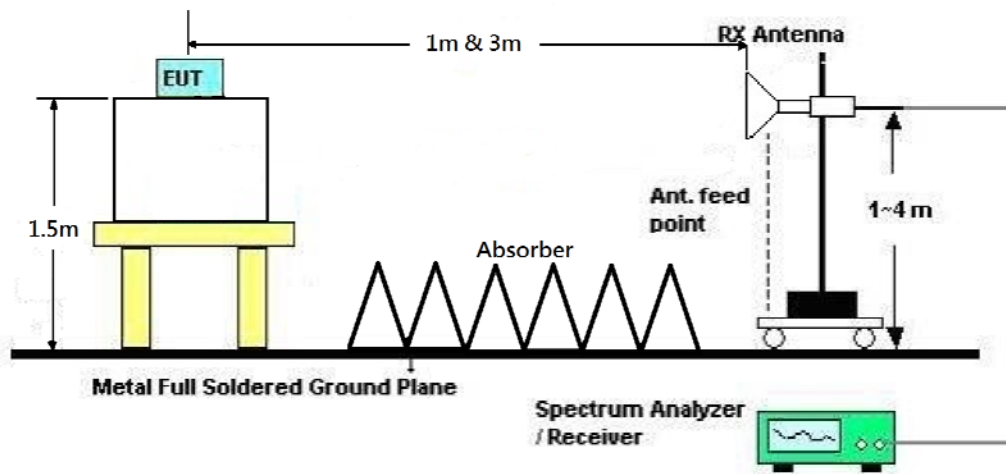

4.5.5. Test Deviation

There is no deviation with the original standard.

4.5.6. EUT Operation during Test

The EUT was programmed to be in continuously transmitting mode.

4.5.7. Results for Radiated Emissions (1GHz~40GHz)

Temperature	20°C	Humidity	55%
Test Engineer	Eason Chen	Configurations	IEEE 802.11a CH 149 / Chain 1 + Chain 2

Horizontal

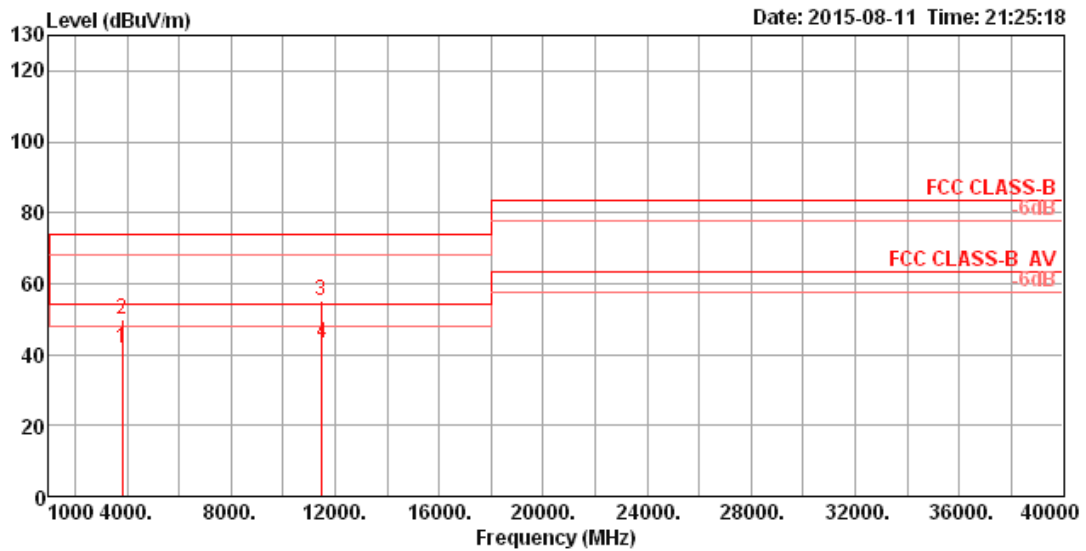

	Freq	Level	Limit	Over	Read	Cable	Antenna	Preamp	A/Pos	T/Pos	Remark	PoI/Phase
	MHz	dBuV/m	dBuV/m	dB	dBuV	dB	dB/m	dB	cm	deg		
1	3829.98	41.51	54.00	-12.49	36.74	5.82	32.12	33.17	170	291	Average	HORIZONTAL
2	3830.00	49.68	74.00	-24.32	44.91	5.82	32.12	33.17	170	291	Peak	HORIZONTAL
3	11474.00	55.26	74.00	-18.74	39.05	10.71	38.87	33.37	165	4	Peak	HORIZONTAL
4	11482.80	43.14	54.00	-10.86	26.92	10.71	38.88	33.37	165	4	Average	HORIZONTAL

Vertical

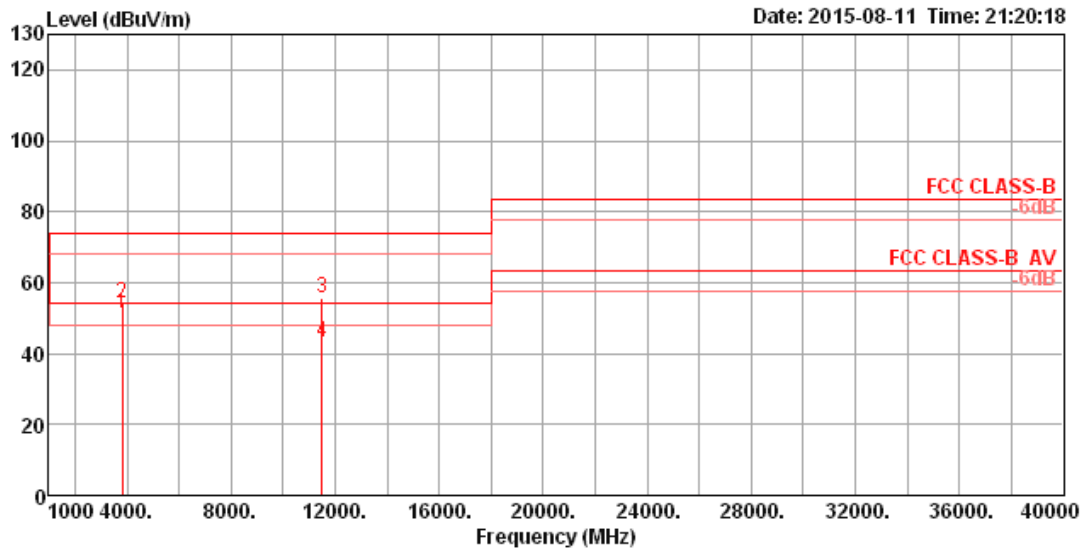

	Freq	Level	Limit	Over	Read	CableAntenna	Preamp	A/Pos	T/Pos	Remark	Pol/Phase
	MHz	dBuV/m	dBuV/m	dB	dBuV	dB	dB/m	dB	cm	deg	
1	3829.96	51.34	54.00	-2.66	46.57	5.82	32.12	33.17	194	88 Average	VERTICAL
2	3830.00	54.09	74.00	-19.91	49.32	5.82	32.12	33.17	194	88 Peak	VERTICAL
3	11486.88	55.45	74.00	-18.55	39.23	10.71	38.88	33.37	165	271 Peak	VERTICAL
4	11489.52	43.35	54.00	-10.65	27.13	10.71	38.88	33.37	165	271 Average	VERTICAL

Temperature	20°C	Humidity	55%
Test Engineer	Eason Chen	Configurations	IEEE 802.11a CH 157 / Chain 1 + Chain 2

Horizontal

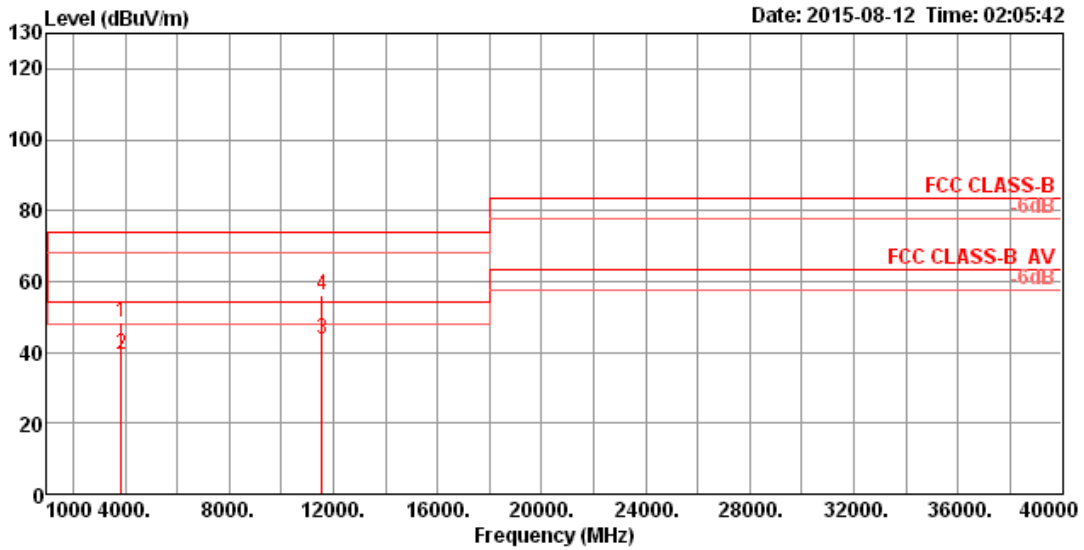

	Freq	Level	Limit Line	Over Limit	Read Level	CableAntenna Loss	Preamp Factor	A/Pos	T/Pos	Remark	Pol/Phase
	MHz	dBuV/m	dBuV/m	dB	dBuV	dB	dB/m	dB	cm	deg	
1	3856.38	48.26	74.00	-25.74	43.37	5.84	32.21	33.16	166	283 Peak	HORIZONTAL
2	3856.73	39.37	54.00	-14.63	34.48	5.84	32.21	33.16	166	283 Average	HORIZONTAL
3	11567.36	43.84	54.00	-10.16	27.53	10.75	38.94	33.38	165	276 Average	HORIZONTAL
4	11571.92	56.31	74.00	-17.69	40.00	10.76	38.94	33.39	165	276 Peak	HORIZONTAL

Vertical

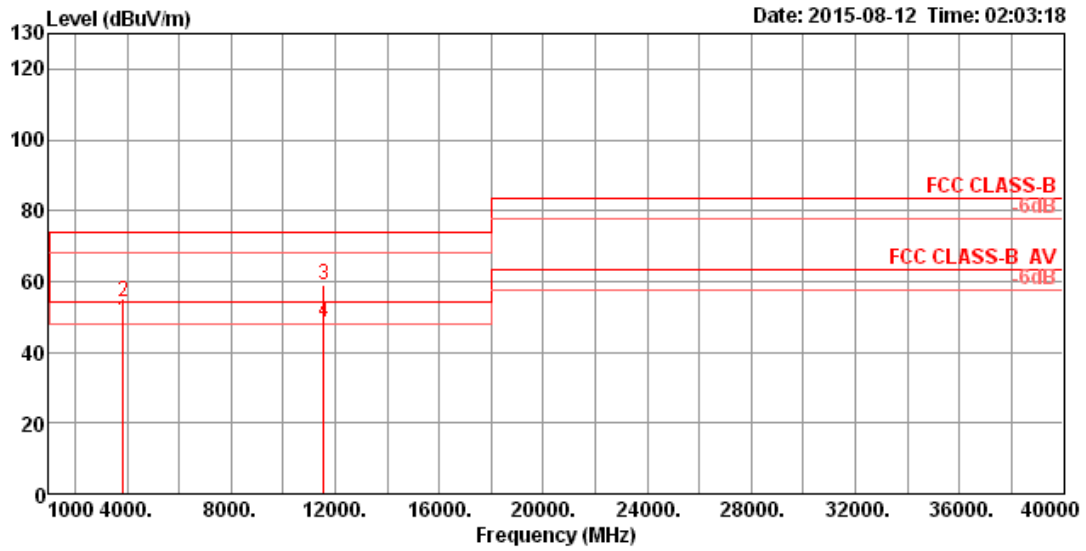

	Freq	Level	Limit	Over	Read	CableAntenna	Preamp	A/Pos	T/Pos	Remark	Pol/Phase
	MHz	dBuV/m	dBuV/m	dB	dBuV	dB	dB/m	dB	cm	deg	
1	3856.62	48.90	54.00	-5.10	44.01	5.84	32.21	33.16	155	266 Average	VERTICAL
2	3856.76	54.40	74.00	-19.60	49.51	5.84	32.21	33.16	155	266 Peak	VERTICAL
3	11568.72	58.83	74.00	-15.17	42.52	10.75	38.94	33.38	140	160 Peak	VERTICAL
4	11571.50	48.28	54.00	-5.72	31.97	10.76	38.94	33.39	140	160 Average	VERTICAL

Temperature	20°C	Humidity	55%
Test Engineer	Eason Chen	Configurations	IEEE 802.11a CH 165 / Chain 1 + Chain 2

Horizontal

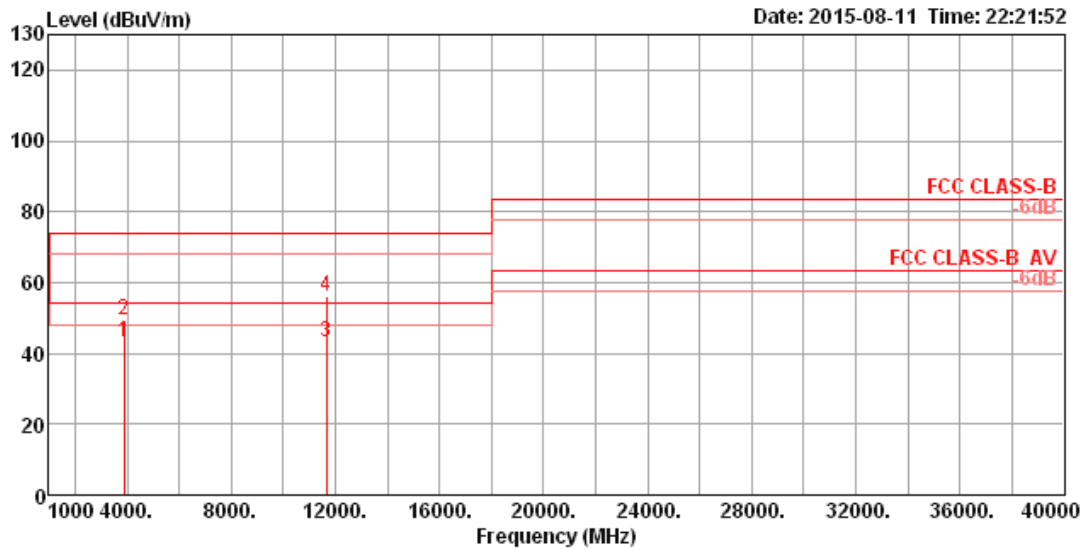

	Freq	Level	Limit Line	Over Limit	Read Level	CableAntenna Loss	Preamp Factor	A/Pos	T/Pos	Remark	PoI/Phase
	MHz	dBuV/m	dBuV/m	dB	dBuV	dB	dB/m	dB	cm	deg	
1	3883.29	42.97	54.00	-11.03	37.97	5.85	32.31	33.16	114	293 Average	HORIZONTAL
2	3883.43	49.52	74.00	-24.48	44.52	5.85	32.31	33.16	114	293 Peak	HORIZONTAL
3	11650.45	42.94	54.00	-11.06	26.56	10.81	38.98	33.41	165	268 Average	HORIZONTAL
4	11650.84	56.34	74.00	-17.66	39.95	10.81	38.99	33.41	165	268 Peak	HORIZONTAL

Vertical

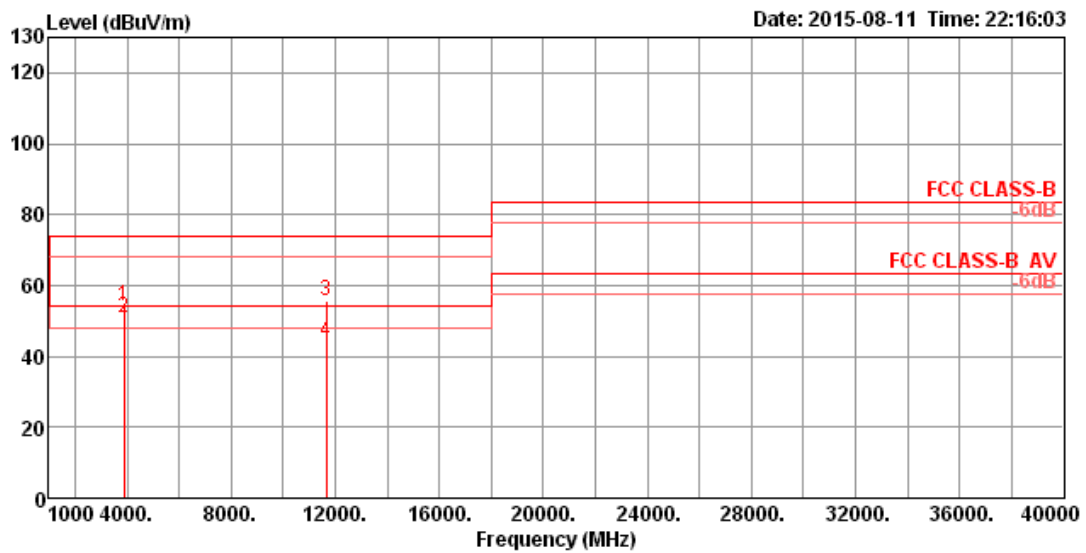

	Freq	Level	Limit	Over	Read	CableAntenna	Preamp	A/Pos	T/Pos	Remark	Pol/Phase	
	MHz	dBuV/m	dBuV/m	dB	dBuV	dB	dB/m	dB	cm	deg		
1	3883.25	54.19	74.00	-19.81	49.19	5.85	32.31	33.16	165	268	Peak	VERTICAL
2	3883.29	50.61	54.00	-3.39	45.61	5.85	32.31	33.16	165	268	Average	VERTICAL
3	11646.24	55.71	74.00	-18.29	39.34	10.79	38.98	33.40	165	143	Peak	VERTICAL
4	11651.28	44.00	54.00	-10.00	27.61	10.81	38.99	33.41	165	143	Average	VERTICAL

Temperature	20°C	Humidity	55%
Test Engineer	Eason Chen	Configurations	IEEE 802.11n MCS0 HT20 CH 149 / Chain 1 + Chain 2

Horizontal

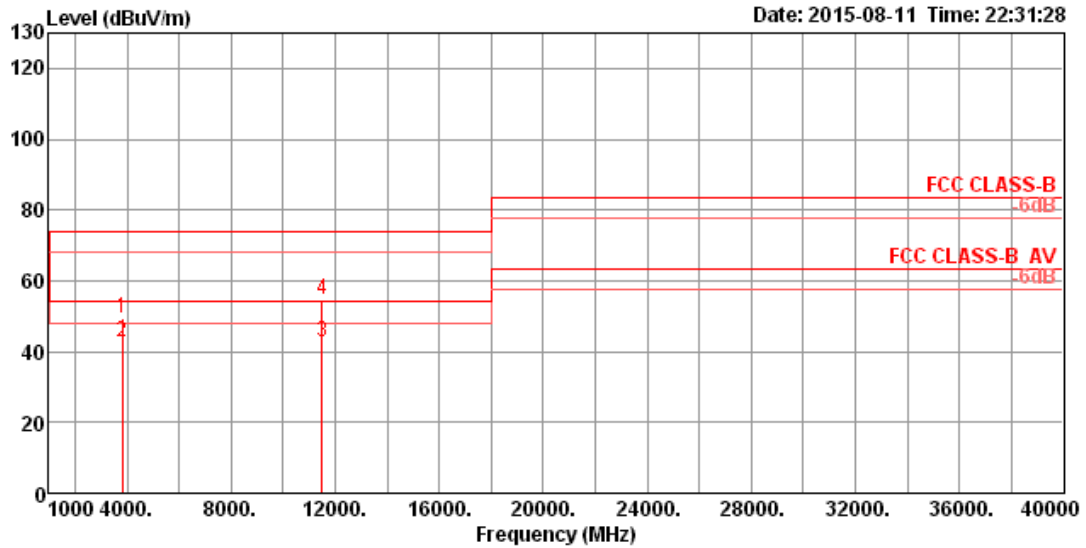

	Freq	Level	Limit	Over	Read	CableAntenna	Preamp	A/Pos	T/Pos	Remark	PoI/Phase
	MHz	dBuV/m	dBuV/m	dB	dBuV	dB	dB/m	dB	cm	deg	
1	3829.94	49.64	74.00	-24.36	44.87	5.82	32.12	33.17	100	297 Peak	HORIZONTAL
2	3829.97	42.91	54.00	-11.09	38.14	5.82	32.12	33.17	100	297 Average	HORIZONTAL
3	11506.40	42.74	54.00	-11.26	26.49	10.72	38.90	33.37	165	156 Average	HORIZONTAL
4	11509.92	54.84	74.00	-19.16	38.59	10.72	38.90	33.37	165	156 Peak	HORIZONTAL

Vertical

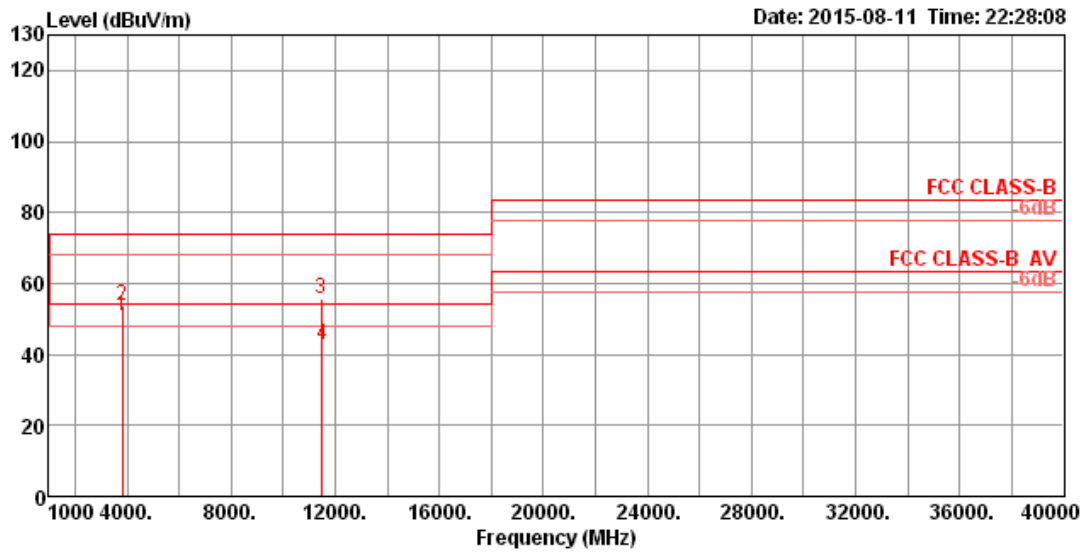

	Freq	Level	Limit Line	Over Limit	Read Level	CableAntenna Loss	Preamp Factor	A/Pos	T/Pos	Remark	Pol/Phase
	MHz	dBuV/m	dBuV/m	dB	dBuV	dB	dB/m	dB	cm	deg	
1	3829.96	50.71	54.00	-3.29	45.94	5.82	32.12	33.17	207	87 Average	VERTICAL
2	3829.97	53.84	74.00	-20.16	49.07	5.82	32.12	33.17	207	87 Peak	VERTICAL
3	11471.76	55.80	74.00	-18.20	39.59	10.71	38.87	33.37	165	291 Peak	VERTICAL
4	11504.64	42.70	54.00	-11.30	26.45	10.72	38.90	33.37	165	291 Average	VERTICAL

Temperature	20°C	Humidity	55%
Test Engineer	Eason Chen	Configurations	IEEE 802.11n MCS0 HT20 CH 157 / Chain 1 + Chain 2

Horizontal

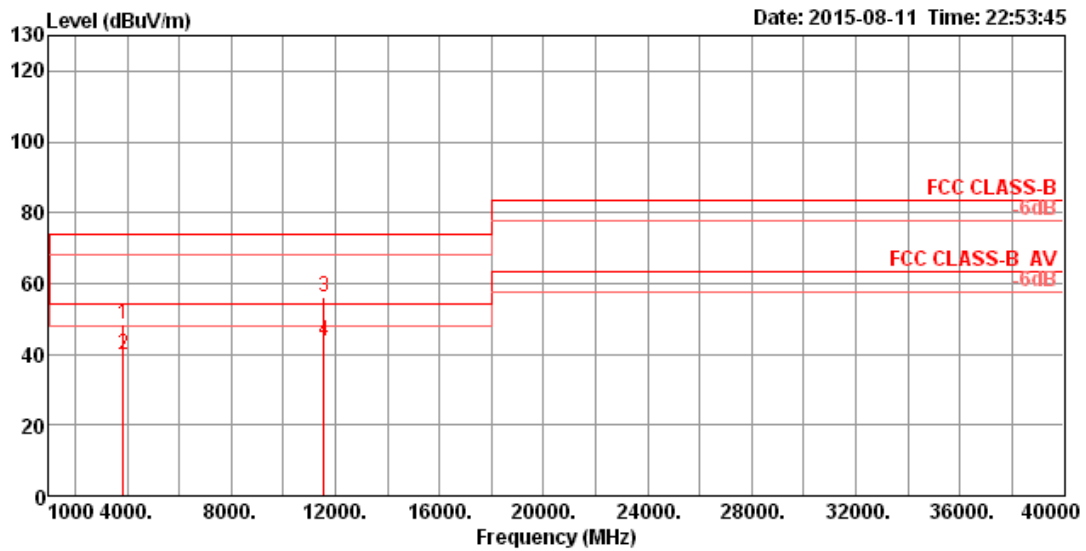

	Freq	Level	Limit Line	Over Limit	Read Level	Cable Loss	Antenna Factor	Preamp Factor	A/Pos	T/Pos	Remark	PoI/Phase
	MHz	dBuV/m	dBuV/m	dB	dBuV	dB	dB/m	dB	cm	deg		
1	3856.73	48.35	74.00	-25.65	43.46	5.84	32.21	33.16	166	283	Peak	HORIZONTAL
2	3856.79	39.69	54.00	-14.31	34.80	5.84	32.21	33.16	166	283	Average	HORIZONTAL
3	11569.08	55.93	74.00	-18.07	39.62	10.75	38.94	33.38	165	84	Peak	HORIZONTAL
4	11570.52	43.70	54.00	-10.30	27.39	10.76	38.94	33.39	165	84	Average	HORIZONTAL

Vertical

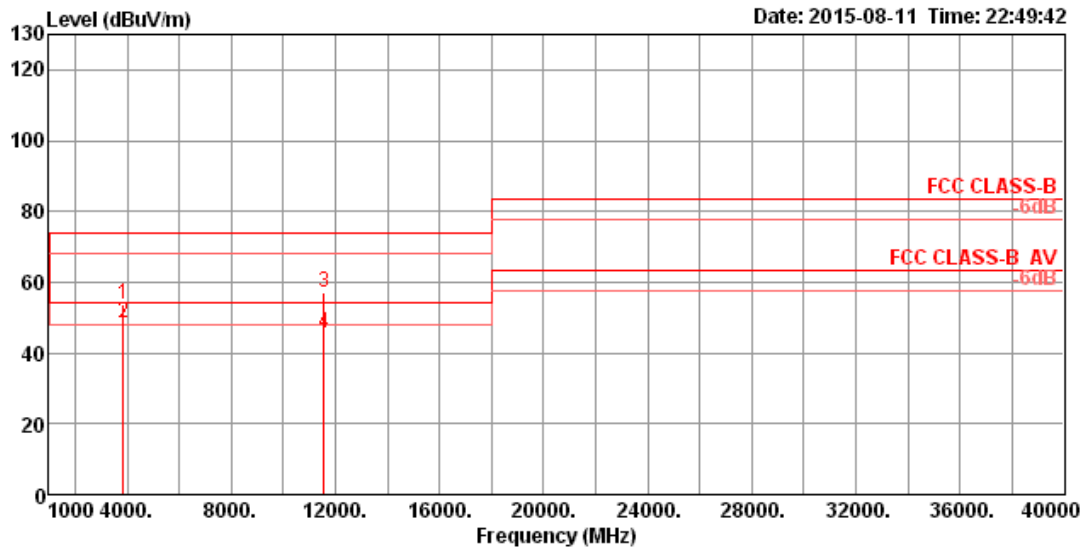

	Freq	Level	Limit Line	Over Limit	Read Level	CableAntenna Loss	Preamp Factor	A/Pos	T/Pos	Remark	Pol/Phase
	MHz	dBuV/m	dBuV/m	dB	dBuV	dB	dB/m	dB	cm	deg	
1	3856.64	53.82	74.00	-20.18	48.93	5.84	32.21	33.16	166	266 Peak	VERTICAL
2	3856.72	48.50	54.00	-5.50	43.61	5.84	32.21	33.16	166	266 Average	VERTICAL
3	11561.12	56.96	74.00	-17.04	40.66	10.75	38.93	33.38	190	168 Peak	VERTICAL
4	11570.88	45.58	54.00	-8.42	29.27	10.76	38.94	33.39	190	168 Average	VERTICAL

Temperature	20°C	Humidity	55%
Test Engineer	Eason Chen	Configurations	IEEE 802.11n MCS0 HT20 CH 165 / Chain 1 + Chain 2

Horizontal

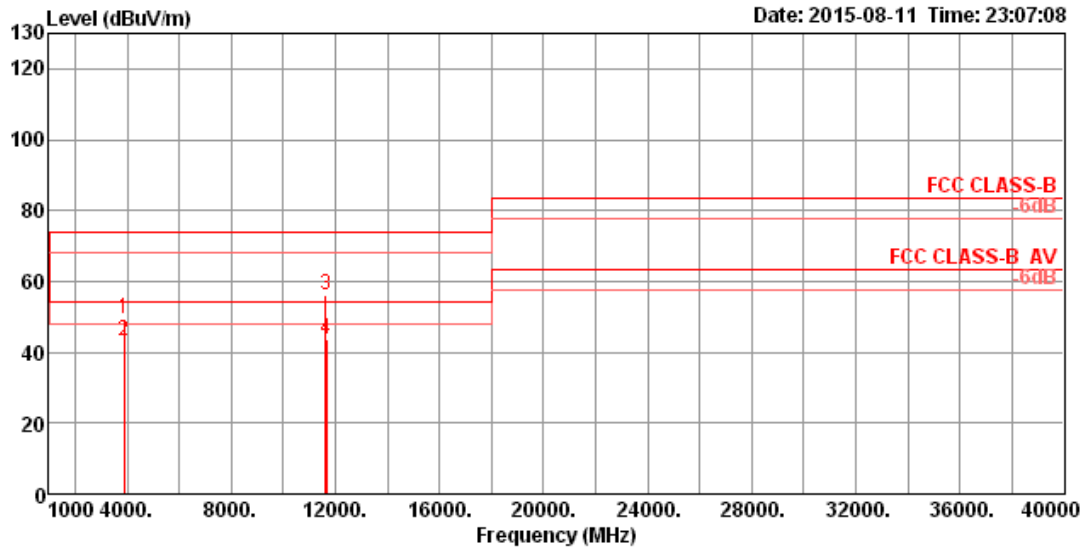

	Freq	Level	Limit Line	Over Limit	Read Level	CableAntenna Loss	Preamp Factor	A/Pos	T/Pos	Remark	PoI/Phase	
	MHz	dBuV/m	dBuV/m	dB	dBuV	dB	dB/m	dB	cm	deg		
1	3883.29	49.50	74.00	-24.50	44.50	5.85	32.31	33.16	140	294	Peak	HORIZONTAL
2	3883.32	43.04	54.00	-10.96	38.04	5.85	32.31	33.16	140	294	Average	HORIZONTAL
3	11636.00	56.16	74.00	-17.84	39.79	10.79	38.98	33.40	165	171	Peak	HORIZONTAL
4	11652.08	43.47	54.00	-10.53	27.08	10.81	38.99	33.41	165	171	Average	HORIZONTAL

Vertical

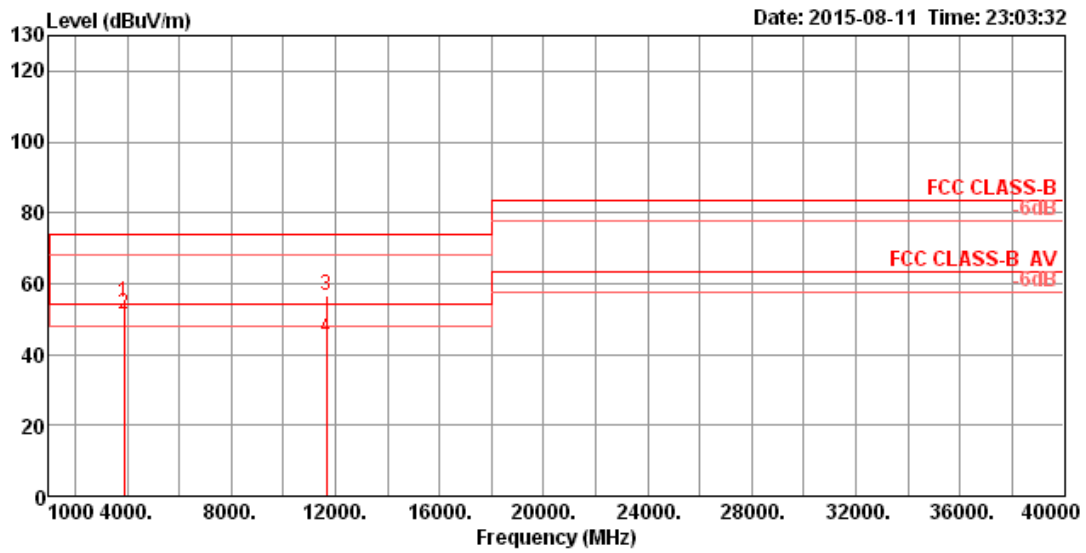

	Freq	Level	Limit	Over	Read	CableAntenna	Preamp	A/Pos	T/Pos	Remark	Pol/Phase	
	MHz	dBuV/m	dBuV/m	dB	dBuV	dB	dB/m	dB	cm	deg		
1	3883.31	54.69	74.00	-19.31	49.69	5.85	32.31	33.16	160	262	Peak	VERTICAL
2	3883.31	51.20	54.00	-2.80	46.20	5.85	32.31	33.16	160	262	Average	VERTICAL
3	11647.68	56.76	74.00	-17.24	40.38	10.81	38.98	33.41	165	147	Peak	VERTICAL
4	11650.64	44.75	54.00	-9.25	28.36	10.81	38.99	33.41	165	147	Average	VERTICAL

Temperature	20°C	Humidity	55%
Test Engineer	Eason Chen	Configurations	IEEE 802.11n MCS0 HT40 CH 151 / Chain 1 + Chain 2

Horizontal

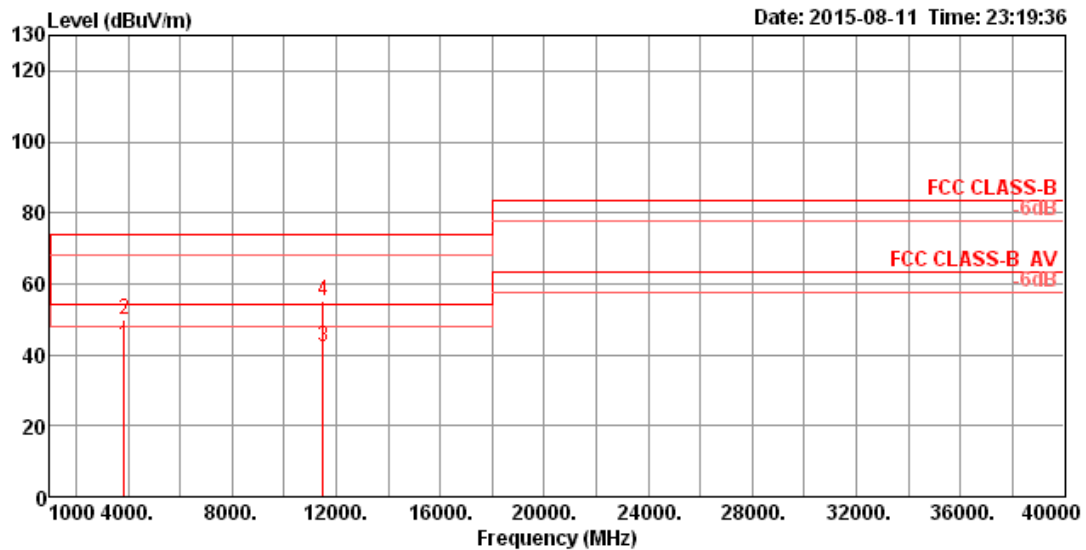

	Freq	Level	Limit	Over	Read	CableAntenna	Preamp	A/Pos	T/Pos	Remark	PoI/Phase
	MHz	dBuV/m	dBuV/m	dB	dBuV	dB	dB/m	dB	cm	deg	
1	3836.59	42.80	54.00	-11.20	37.98	5.82	32.17	33.17	155	289 Average	HORIZONTAL
2	3836.68	50.03	74.00	-23.97	45.21	5.82	32.17	33.17	155	289 Peak	HORIZONTAL
3	11512.84	42.34	54.00	-11.66	26.09	10.72	38.90	33.37	165	203 Average	HORIZONTAL
4	11513.68	55.30	74.00	-18.70	39.05	10.72	38.90	33.37	165	203 Peak	HORIZONTAL

Vertical

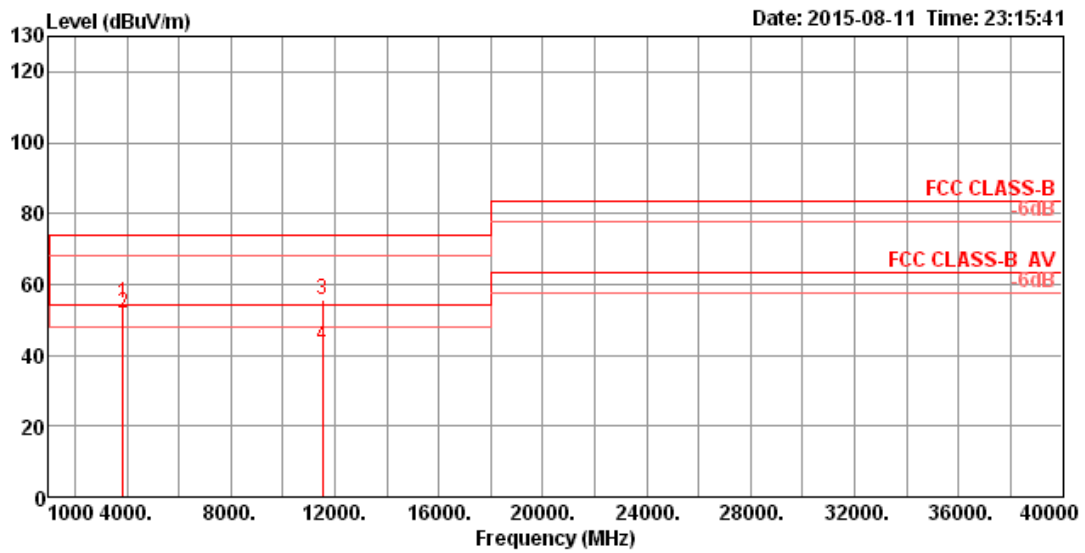

	Freq	Level	Limit	Over	Read	CableAntenna	Preamp	A/Pos	T/Pos	Remark	Pol/Phase	
	MHz	dBuV/m	dBuV/m	dB	dBuV	dB	dB/m	dB	cm	deg		
1	3836.61	54.84	74.00	-19.16	50.02	5.82	32.17	33.17	177	258	Peak	VERTICAL
2	3836.66	51.97	54.00	-2.03	47.15	5.82	32.17	33.17	177	258	Average	VERTICAL
3	11520.40	55.69	74.00	-18.31	39.43	10.73	38.91	33.38	165	95	Peak	VERTICAL
4	11529.60	42.66	54.00	-11.34	26.40	10.73	38.91	33.38	165	95	Average	VERTICAL

Temperature	20°C	Humidity	55%
Test Engineer	Eason Chen	Configurations	IEEE 802.11n MCS0 HT40 CH 159 / Chain 1 + Chain 2

Horizontal

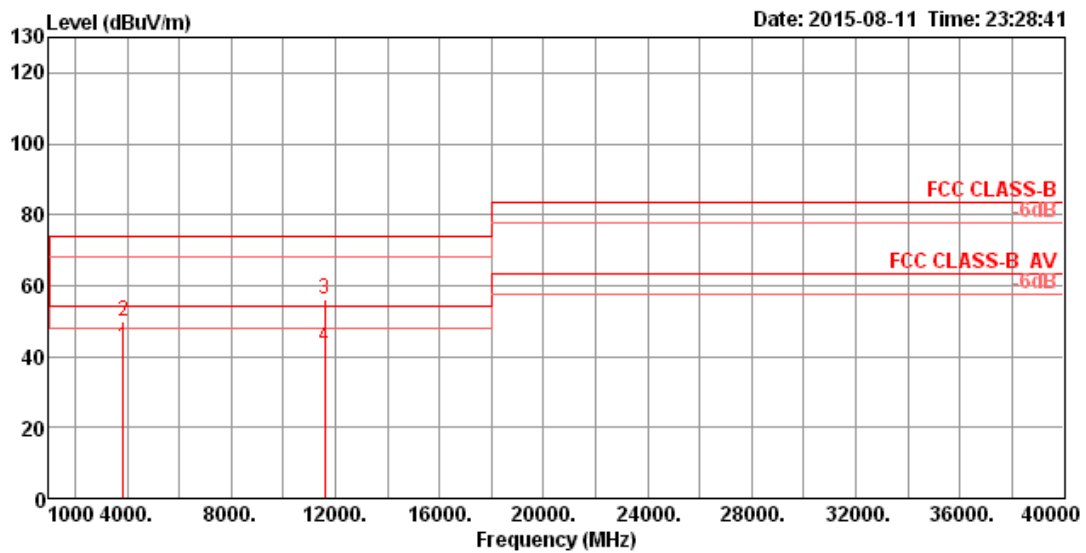

	Freq	Level	Limit Line	Over Limit	Read Level	CableAntenna Loss	Preamp Factor	A/Pos	T/Pos	Remark	Pol/Phase
	MHz	dBuV/m	dBuV/m	dB	dBuV	dB	dB/m	dB	cm	deg	
1	3863.32	42.74	54.00	-11.26	37.85	5.84	32.21	33.16	164	287 Average	HORIZONTAL
2	3863.32	49.88	74.00	-24.12	44.99	5.84	32.21	33.16	164	287 Peak	HORIZONTAL
3	11589.30	56.04	74.00	-17.96	39.72	10.76	38.95	33.39	165	237 Peak	HORIZONTAL
4	11590.09	42.88	54.00	-11.12	26.56	10.76	38.95	33.39	165	237 Average	HORIZONTAL

Vertical

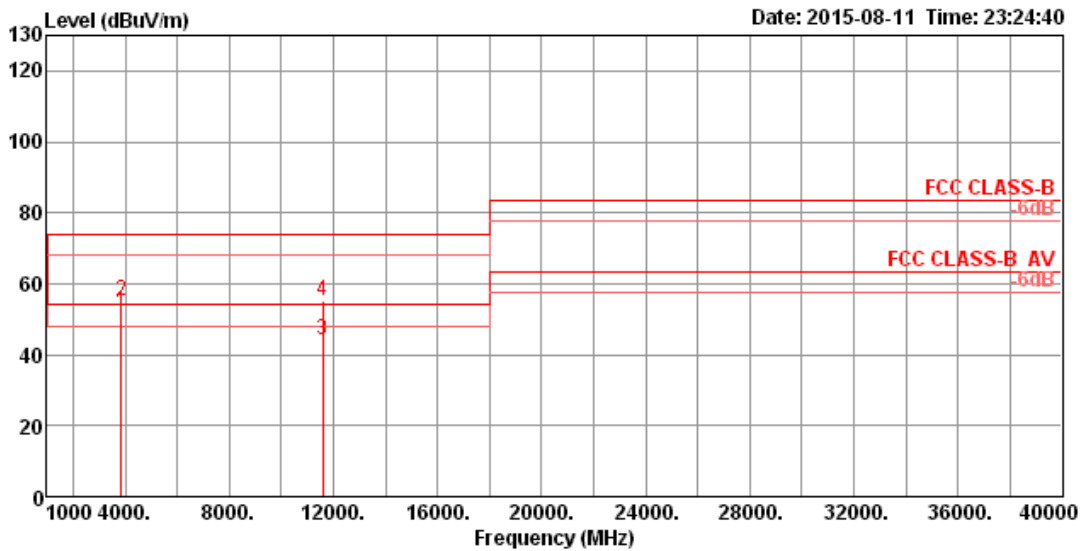

	Freq	Level	Limit	Over	Read	CableAntenna	Preamp	A/Pos	T/Pos	Remark	Pol/Phase
	MHz	dBuV/m	dBuV/m	dB	dBuV	dB	dB/m	dB	cm	deg	
1	3863.33	51.83	54.00	-2.17	46.94	5.84	32.21	33.16	150	269 Average	VERTICAL
2	3863.34	55.01	74.00	-18.99	50.12	5.84	32.21	33.16	150	269 Peak	VERTICAL
3	11590.04	44.37	54.00	-9.63	28.05	10.76	38.95	33.39	165	59 Average	VERTICAL
4	11590.72	55.28	74.00	-18.72	38.96	10.76	38.95	33.39	165	59 Peak	VERTICAL

Note:

The amplitude of spurious emissions that are attenuated by more than 20dB below the permissible value has no need to be reported.

Emission level (dBuV/m) = 20 log Emission level (uV/m).

Corrected Reading: Antenna Factor + Cable Loss + Read Level - Preamp Factor = Level.

4.6. Band Edge Emissions Measurement

4.6.1. Limit

For transmitters operating in the 5.725-5.85 GHz band: all emissions within the frequency range from the band edge to 10 MHz above or below the band edge shall not exceed an e.i.r.p. of -17 dBm/MHz; for frequencies 10 MHz or greater above or below the band edge, emissions shall not exceed an e.i.r.p. of -27 dBm/MHz.

In addition, In case the emission fall within the restricted band specified on 15.205(a), then the 15.209(a) limit in the table below has to be followed.

Frequencies (MHz)	Field Strength (micorvolts/meter)	Measurement Distance (meters)
0.009~0.490	2400/F(kHz)	300
0.490~1.705	24000/F(kHz)	30
1.705~30.0	30	30
30~88	100	3
88~216	150	3
216~960	200	3
Above 960	500	3

4.6.2. Measuring Instruments and Setting

Please refer to section 5 of equipments list in this report. The following table is the setting of the spectrum analyzer.

Spectrum Parameter	Setting
Attenuation	Auto
Span Frequency	100 MHz
RBW / VBW (Emission in restricted band)	1 MHz / 3MHz for Peak, 1 MHz / 1/T for Average
RBW / VBW (Emission in non-restricted band)	1 MHz / 3MHz for Peak

4.6.3. Test Procedures

1. The test procedure is the same as section 0.

4.6.4. Test Setup Layout

This test setup layout is the same as that shown in section 4.5.4.

4.6.5. Test Deviation

There is no deviation with the original standard.

4.6.6. EUT Operation during Test

The EUT was programmed to be in continuously transmitting mode.

4.6.7. Test Result of Band Edge and Fundamental Emissions

Temperature	20°C	Humidity	55%
Test Engineer	Eason Chen	Configurations	IEEE 802.11a CH 149, 157, 165 / Chain 1 + Chain 2

Channel 149

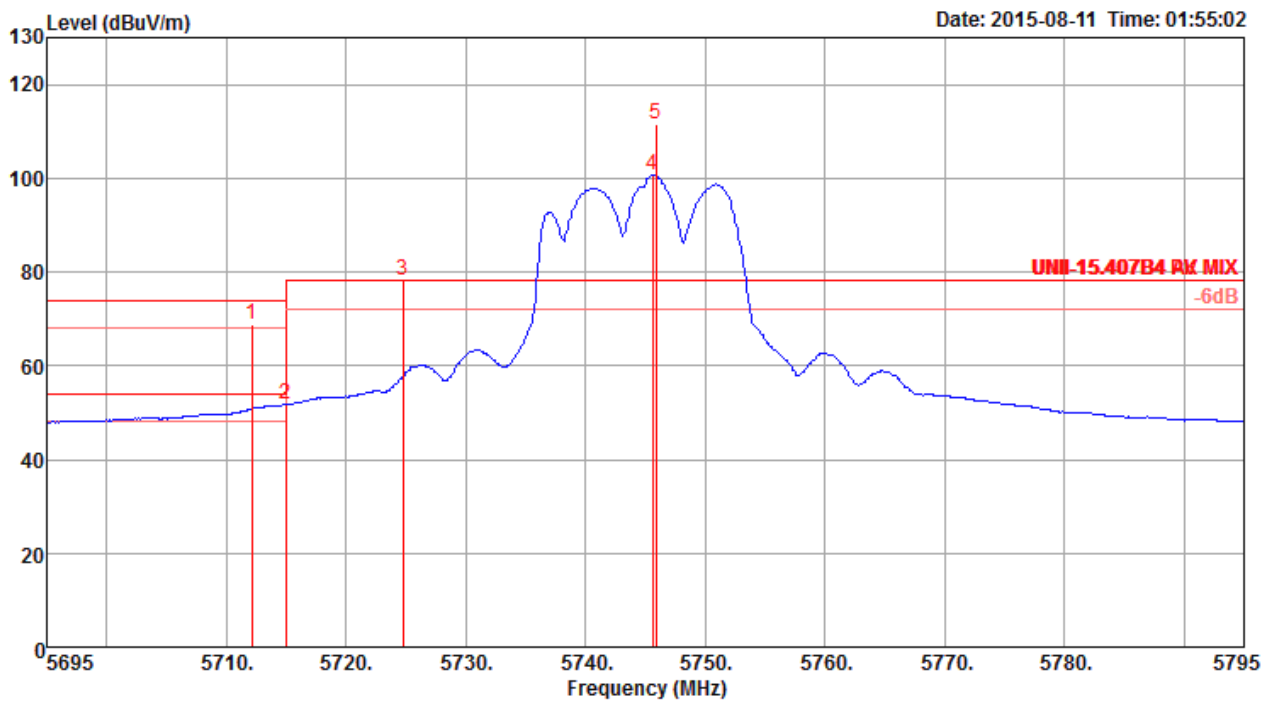

	Freq	Level	Limit	Over	Read	CableAntenna	Preamp	Remark	A/Pos	T/Pos	Pol/Phase
	MHz	dBuV/m	dBuV/m	dB	dBuV	dB	dB/m	dB	cm	deg	
1	5712.15	68.97	74.00	-5.03	62.92	6.44	34.64	35.03 Peak	174	316	VERTICAL
2	5715.00	51.67	54.00	-2.33	45.62	6.44	34.64	35.03 Average	174	316	VERTICAL
3	5724.74	78.11	78.20	-0.09	72.05	6.45	34.64	35.03 Peak	174	316	VERTICAL
4	5745.58	100.63			94.57	6.45	34.65	35.04 Average	174	316	VERTICAL
5	5745.87	111.40			105.34	6.45	34.65	35.04 Peak	174	316	VERTICAL

Item 4, 5 are the fundamental frequency at 5745 MHz.

Note: Both antenna polarizations have been tested and only the worst case was recorded in test report.

Channel 157

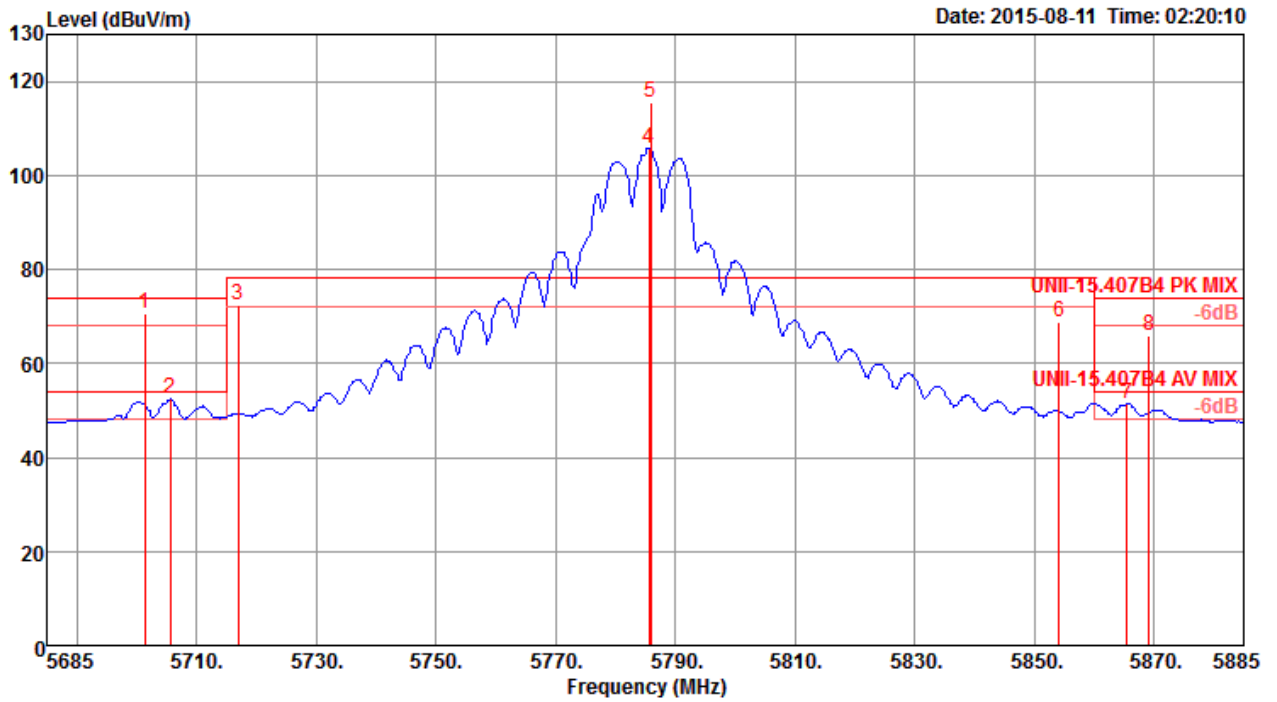

	Freq	Level	Limit Line	Over Limit	Read Level	CableAntenna Loss	Antenna Factor	Preamp Factor	Remark	A/Pos	T/Pos	Pol/Phase
	MHz	dBuV/m	dBuV/m	dB	dBuV	dB	dB/m	dB		cm	deg	
1	5701.35	70.64	74.00	-3.36	64.59	6.44	34.64	35.03	Peak	162	315	VERTICAL
2	5705.69	52.34	54.00	-1.66	46.29	6.44	34.64	35.03	Average	162	315	VERTICAL
3	5716.98	72.49	78.20	-5.71	66.44	6.44	34.64	35.03	Peak	162	315	VERTICAL
4	5785.58	105.78			99.70	6.47	34.66	35.05	Average	162	315	VERTICAL
5	5785.87	115.54			109.46	6.47	34.66	35.05	Peak	162	315	VERTICAL
6	5854.18	68.83	78.20	-9.37	62.72	6.50	34.67	35.06	Peak	162	315	VERTICAL
7	5865.46	51.43	54.00	-2.57	45.33	6.50	34.67	35.07	Average	162	315	VERTICAL
8	5869.23	65.96	74.00	-8.04	59.86	6.50	34.67	35.07	Peak	162	315	VERTICAL

Item 4, 5 are the fundamental frequency at 5785 MHz.

Note: Both antenna polarizations have been tested and only the worst case was recorded in test report.

Channel 165

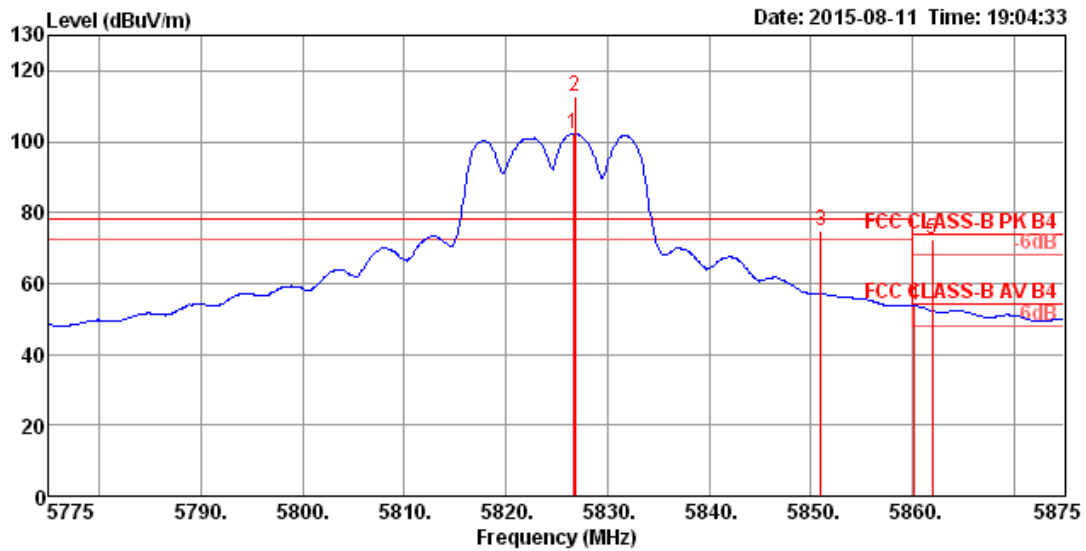

	Freq	Level	Limit Line	Over Limit	Read Level	CableAntenna Loss	Antenna Factor	Preamp Factor	A/Pos	T/Pos	Remark	PoI/Phase
	MHz	dBuV/m	dBuV/m	dB	dBuV	dB	dB/m	dB	cm	deg		
1	5826.60	102.37			94.11	6.92	34.50	33.16	174	126	Average	VERTICAL
2	5826.80	112.77			104.51	6.92	34.50	33.16	174	126	Peak	VERTICAL
3	5851.00	74.69	78.20	-3.51	66.40	6.95	34.51	33.17	174	126	Peak	VERTICAL
4	5860.20	53.79	54.00	-0.21	45.48	6.97	34.52	33.18	174	126	Average	VERTICAL
5	5862.00	72.56	74.00	-1.44	64.25	6.97	34.52	33.18	174	126	Peak	VERTICAL

Item 1, 2 are the fundamental frequency at 5825 MHz.

Note: Both antenna polarizations have been tested and only the worst case was recorded in test report.

Temperature	20°C	Humidity	55%
Test Engineer	Eason Chen	Configurations	IEEE 802.11n MCS0 HT20 CH 149, 157, 165 / Chain 1 + Chain 2

Channel 149

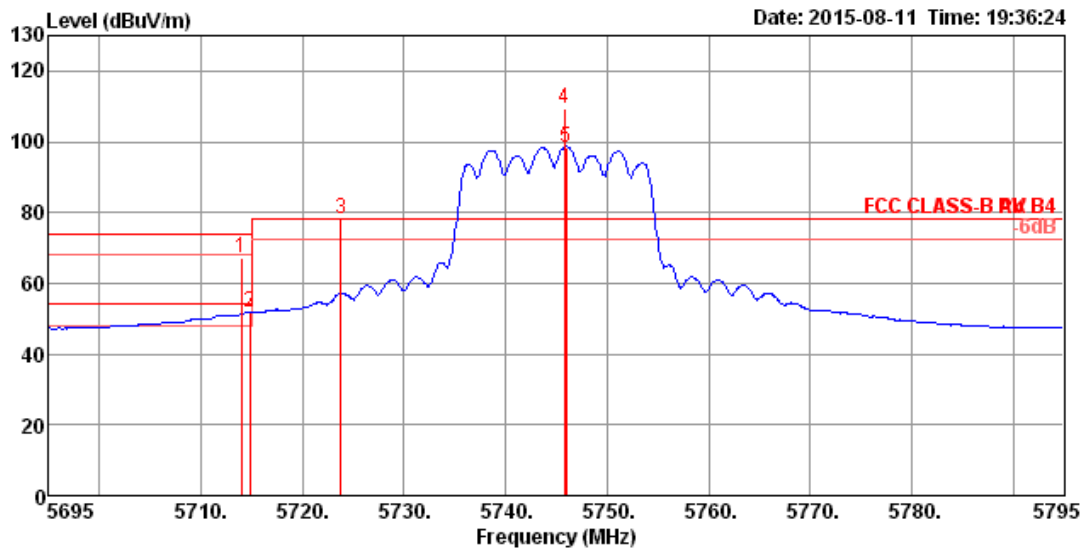

	Freq	Level	Limit Line	Over Limit	Read Level	Cable Loss	Antenna Factor	Preamp Factor	A/Pos	T/Pos	Remark	PoI/Phase
	MHz	dBuV/m	dBuV/m	dB	dBuV	dB	dB/m	dB	cm	deg		
1	5714.00	67.30	74.00	-6.70	59.18	6.83	34.42	33.13	186	126	Peak	VERTICAL
2	5714.80	51.85	54.00	-2.15	43.73	6.83	34.42	33.13	186	126	Average	VERTICAL
3	5723.80	78.15	78.20	-0.05	70.02	6.83	34.43	33.13	186	126	Peak	VERTICAL
4	5745.80	109.32			101.16	6.86	34.44	33.14	186	126	Peak	VERTICAL
5	5746.00	98.58			90.42	6.86	34.44	33.14	186	126	Average	VERTICAL

Item 4, 5 are the fundamental frequency at 5745 MHz.

Note: Both antenna polarizations have been tested and only the worst case was recorded in test report.

Channel 157

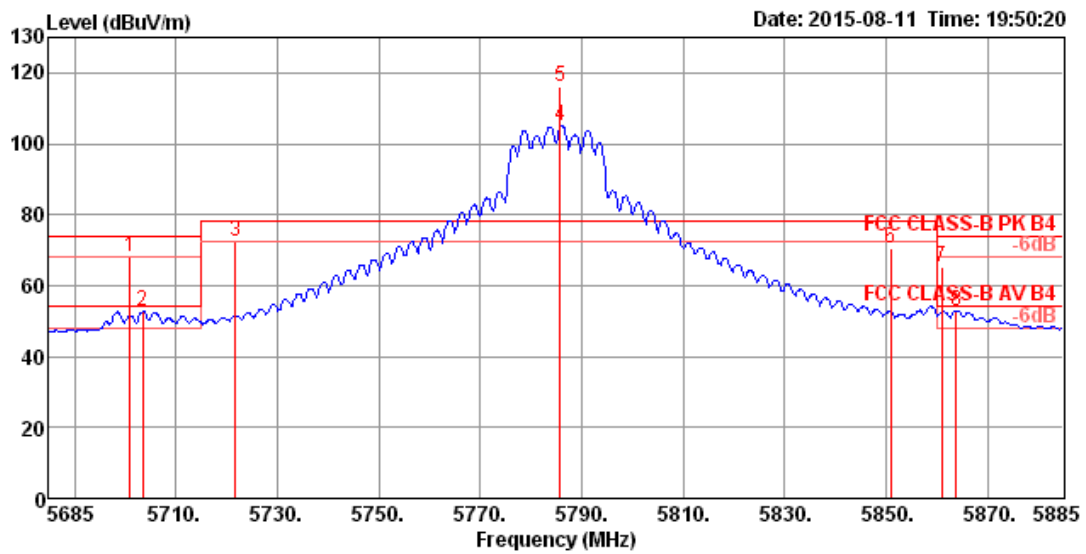

	Freq	Level	Limit	Over	Read	CableAntenna	Preamp	A/Pos	T/Pos	Remark	PoI/Phase	
	MHz	dBuV/m	dBuV/m	dB	dBuV	dB	dB/m	dB	cm	deg		
1	5701.00	68.21	74.00	-5.79	60.10	6.81	34.42	33.12	177	128	Peak	VERTICAL
2	5703.40	52.68	54.00	-1.32	44.57	6.81	34.42	33.12	177	128	Average	VERTICAL
3	5721.80	72.41	78.20	-5.79	64.28	6.83	34.43	33.13	177	128	Peak	VERTICAL
4	5785.80	105.06			96.84	6.90	34.48	33.16	177	128	Average	VERTICAL
5	5785.80	116.19			107.97	6.90	34.48	33.16	177	128	Peak	VERTICAL
6	5851.00	70.40	78.20	-7.80	62.11	6.95	34.51	33.17	177	132	Peak	VERTICAL
7	5861.00	65.38	74.00	-8.62	57.07	6.97	34.52	33.18	177	132	Peak	VERTICAL
8	5863.80	52.85	54.00	-1.15	44.54	6.97	34.52	33.18	177	128	Average	VERTICAL

Item 4, 5 are the fundamental frequency at 5785 MHz.

Note: Both antenna polarizations have been tested and only the worst case was recorded in test report.

Channel 165

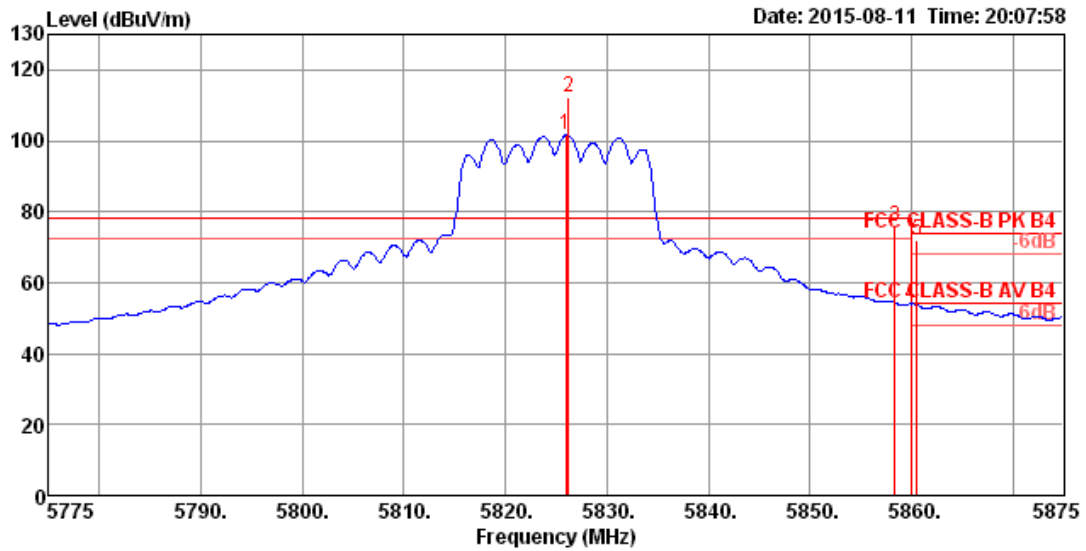

	Freq	Level	Limit Line	Over Limit	Read Level	Cable Loss	Antenna Factor	Preamp Factor	A/Pos	T/Pos	Remark	PoI/Phase
	MHz	dBuV/m	dBuV/m	dB	dBuV	dB	dB/m	dB	cm	deg		
1	5826.00	101.56			93.30	6.92	34.50	33.16	190	128	Average	VERTICAL
2	5826.20	112.37			104.11	6.92	34.50	33.16	190	128	Peak	VERTICAL
3	5858.40	75.71	78.20	-2.49	67.40	6.97	34.52	33.18	190	128	Peak	VERTICAL
4	5860.00	53.96	54.00	-0.04	45.65	6.97	34.52	33.18	190	128	Average	VERTICAL
5	5860.60	72.18	74.00	-1.82	63.87	6.97	34.52	33.18	190	128	Peak	VERTICAL

Item 1, 2 are the fundamental frequency at 5825 MHz.

Note: Both antenna polarizations have been tested and only the worst case was recorded in test report.

Temperature	20°C	Humidity	55%
Test Engineer	Eason Chen	Configurations	IEEE 802.11n MCS0 HT40 CH 151, 159 / Chain 1 + Chain 2

Channel 151

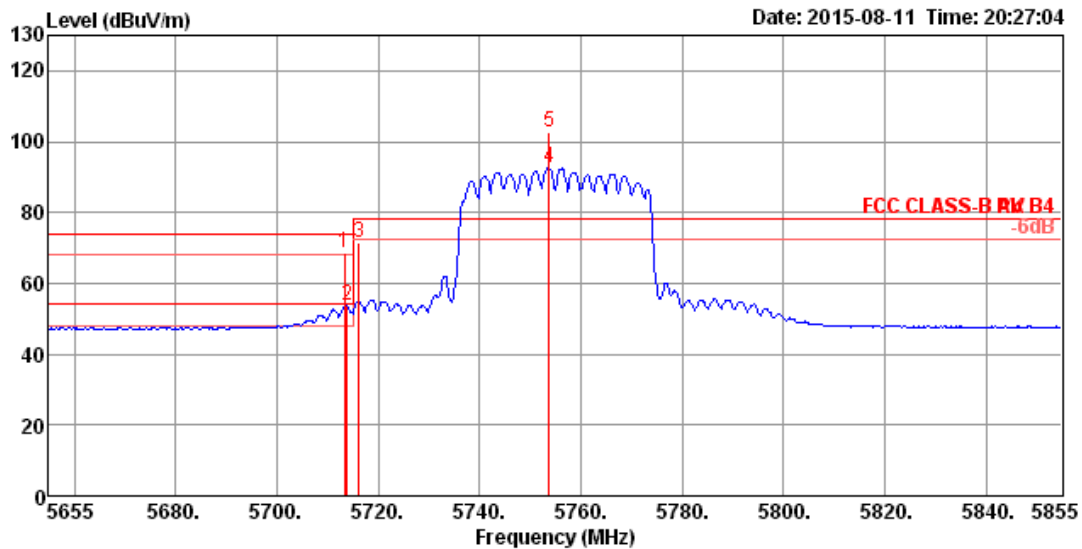

	Freq	Level	Limit Line	Over Limit	Read Level	CableAntenna Loss	Preamp Factor	A/Pos	T/Pos	Remark	PoI/Phase	
	MHz	dBUV/m	dBUV/m	dB	dBUV	dB	dB/m	dB	cm	deg		
1	5713.40	68.58	74.00	-5.42	60.46	6.83	34.42	33.13	176	127	Peak	VERTICAL
2	5713.80	53.76	54.00	-0.24	45.64	6.83	34.42	33.13	176	127	Average	VERTICAL
3	5716.20	71.32	78.20	-6.88	63.20	6.83	34.42	33.13	176	127	Peak	VERTICAL
4	5753.80	92.77			84.59	6.86	34.46	33.14	176	127	Average	VERTICAL
5	5753.80	102.69			94.51	6.86	34.46	33.14	176	127	Peak	VERTICAL

Item 4, 5 are the fundamental frequency at 5755 MHz.

Note: Both antenna polarizations have been tested and only the worst case was recorded in test report.

Channel 159

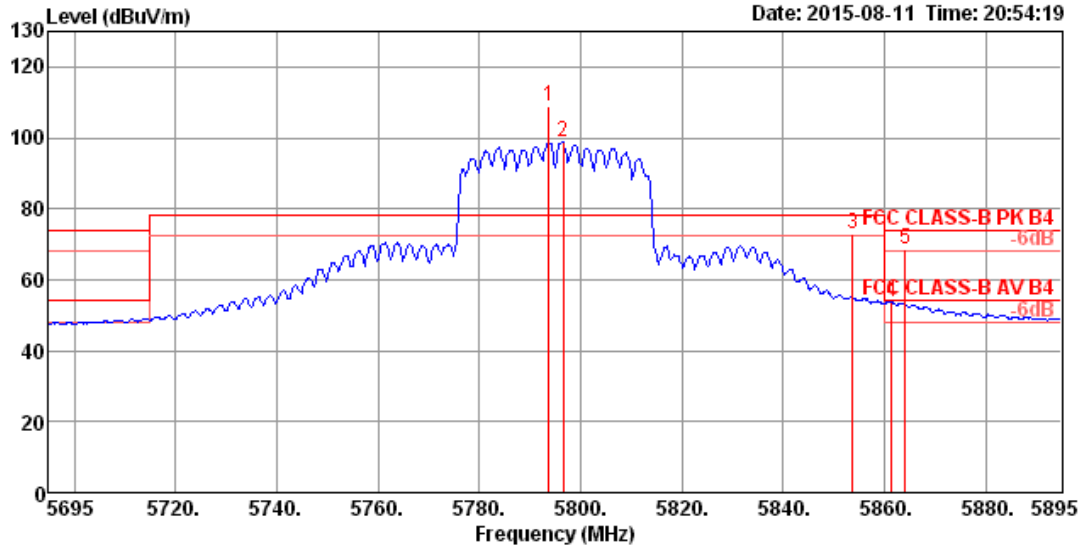

	Freq	Level	Limit	Over	Read	CableAntenna	Preamp	A/Pos	T/Pos	Remark	Pol/Phase
	MHz	dBuV/m	dBuV/m	dB	dBuV	dB	dB/m	dB	cm	deg	
1	5793.80	108.98			100.76	6.90	34.48	33.16	193	130 Peak	VERTICAL
2	5796.60	98.62			90.40	6.90	34.48	33.16	193	130 Average	VERTICAL
3	5853.80	72.95	78.20	-5.25	64.65	6.95	34.52	33.17	193	130 Peak	VERTICAL
4	5861.40	53.85	54.00	-0.15	45.54	6.97	34.52	33.18	193	130 Average	VERTICAL
5	5864.20	68.77	74.00	-5.23	60.46	6.97	34.52	33.18	193	130 Peak	VERTICAL

Item 1, 2 are the fundamental frequency at 5795 MHz.

Note: Both antenna polarizations have been tested and only the worst case was recorded in test report.

4.7. Frequency Stability Measurement

4.7.1. Limit

In-band emission is maintained within the band of operation under all conditions of normal operation as specified in the user's manual.

The transmitter center frequency tolerance shall be ± 20 ppm maximum for the 5 GHz band (IEEE 802.11n specification).

4.7.2. Measuring Instruments and Setting

Please refer to section 5 of equipments list in this report. The following table is the setting of the spectrum analyzer.

Spectrum Parameter	Setting
Attenuation	Auto
Span Frequency	Entire absence of modulation emissions bandwidth
RBW	10 kHz
VBW	10 kHz
Sweep Time	Auto

4.7.3. Test Procedures

1. The transmitter output (antenna port) was connected to the spectrum analyzer.
2. EUT have transmitted absence of modulation signal and fixed channelize.
3. Set the spectrum analyzer span to view the entire absence of modulation emissions bandwidth.
4. Set RBW = 10 kHz, VBW = 10 kHz with peak detector and maxhold settings.
5. f_c is declaring of channel frequency. Then the frequency error formula is $(f_c-f)/f_c \times 10^6$ ppm and the limit is less than ± 20 ppm (IEEE 802.11n specification).
6. Allow sufficient time (approximately 30 min) for the temperature of the chamber to stabilize, turn the EUT on and measure the operating frequency after 2, 5, and 10 minutes.
7. The test extreme voltage is to change the primary supply voltage from 85 to 115 percent of the nominal value
8. Extreme temperature is $0^{\circ}\text{C} \sim 70^{\circ}\text{C}$.

4.7.4. Test Setup Layout

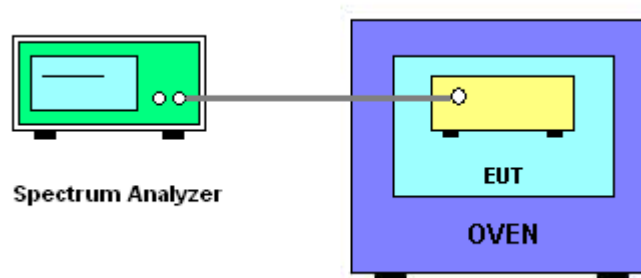

4.7.5. Test Deviation

There is no deviation with the original standard.

4.7.6. EUT Operation during Test

The EUT was programmed to be in continuously un-modulation transmitting mode.

4.7.7. Test Result of Frequency Stability

Temperature	25°C	Humidity	45%
Test Engineer	Lucas Huang	Test Date	Oct. 13, 2015

Mode: 20 MHz / Chain 1

Voltage vs. Frequency Stability

Voltage (V)	Measurement Frequency (MHz)			
	5785 MHz			
	0 Minute	2 Minute	5 Minute	10 Minute
126.50	5784.9886	5784.9872	5784.9854	5784.9833
110.00	5784.9874	5784.9861	5784.9845	5784.9826
93.50	5784.9860	5784.9849	5784.9837	5784.9815
Max. Deviation (MHz)	0.0140	0.0151	0.0163	0.0185
Max. Deviation (ppm)	2.42	2.61	2.82	3.20
Result	Complies			

Temperature vs. Frequency Stability

Temperature (°C)	Measurement Frequency (MHz)			
	5785 MHz			
	0 Minute	2 Minute	5 Minute	10 Minute
0	5784.9899	5784.9887	5784.9868	5784.9846
10	5784.9886	5784.9873	5784.9858	5784.9840
20	5784.9874	5784.9861	5784.9845	5784.9826
30	5784.9860	5784.9849	5784.9835	5784.9819
40	5784.9844	5784.9829	5784.9813	5784.9793
50	5784.9827	5784.9815	5784.9800	5784.9773
60	5784.9826	5784.9812	5784.9798	5784.9771
70	5784.9824	5784.9812	5784.9798	5784.9771
Max. Deviation (MHz)	0.0176	0.0188	0.0202	0.0229
Max. Deviation (ppm)	3.04	3.25	3.49	3.96
Result	Complies			

Mode: 40 MHz / Chain 1

Voltage vs. Frequency Stability

Voltage	Measurement Frequency (MHz)			
(V)	5755 MHz			
	0 Minute	2 Minute	5 Minute	10 Minute
126.50	5754.9867	5754.9853	5754.9835	5754.9814
110.00	5754.9855	5754.9842	5754.9826	5754.9807
93.50	5754.9841	5754.9830	5754.9818	5754.9796
Max. Deviation (MHz)	0.0159	0.0170	0.0182	0.0204
Max. Deviation (ppm)	2.76	2.95	3.16	3.54
Result	Complies			

Temperature vs. Frequency Stability

Temperature	Measurement Frequency (MHz)			
(°C)	5755 MHz			
	0 Minute	2 Minute	5 Minute	10 Minute
0	5754.9880	5754.9868	5754.9849	5754.9827
10	5754.9867	5754.9854	5754.9839	5754.9821
20	5754.9855	5754.9842	5754.9826	5754.9807
30	5754.9841	5754.9830	5754.9816	5754.9800
40	5754.9825	5754.9810	5754.9794	5754.9774
50	5754.9808	5754.9796	5754.9781	5754.9754
60	5754.9806	5754.9794	5754.9780	5754.9752
70	5754.9804	5754.9794	5754.9778	5754.9750
Max. Deviation (MHz)	0.0196	0.0206	0.0222	0.0250
Max. Deviation (ppm)	3.41	3.58	3.86	4.34
Result	Complies			

4.8. Antenna Requirements

4.8.1. Limit

Except for special regulations, the Low-power Radio-frequency Devices must not be equipped with any jacket for installing an antenna with extension cable. An intentional radiator shall be designed to ensure that no antenna other than that furnished by the responsible party shall be used with the device. The use of a permanently attached antenna or of an antenna that uses a unique coupling to the intentional radiator shall be considered sufficient to comply with the provisions of this Section. The manufacturer may design the unit so that the user can replace a broken antenna, but the use of a standard antenna jack or electrical connector is prohibited. Further, this requirement does not apply to intentional radiators that must be professionally installed.

4.8.2. Antenna Connector Construction

Please refer to section 3.3 in this test report; antenna connector complied with the requirements.

5. LIST OF MEASURING EQUIPMENTS

Instrument	Manufacturer	Model No.	Serial No.	Characteristics	Calibration Date	Remark
Horn Antenna	EMCO	3115	00075790	750MHz ~ 18GHz	Oct. 28, 2014	Radiation (03CH01-CB)
Horn Antenna	Schwarzbeck	BBHA 9170	BBHA9170252	15GHz ~ 40GHz	Jul. 21, 2015	Radiation (03CH01-CB)
Pre-Amplifier	Agilent	8449B	3008A02310	1GHz ~ 26.5GHz	Jan. 12, 2015	Radiation (03CH01-CB)
Pre-Amplifier	WM	TF-130N-R1	923365	26GHz ~ 40GHz	Nov. 25, 2014	Radiation (03CH01-CB)
Spectrum Analyzer	R&S	FSP40	100056	9kHz ~ 40GHz	Nov. 06, 2014	Radiation (03CH01-CB)
RF Cable-high	Woken	High Cable-40G-1	N/A	1 GHz ~ 40 GHz	Nov. 15, 2014	Radiation (03CH01-CB)
RF Cable-high	Woken	High Cable-40G-2	N/A	1 GHz ~ 40 GHz	Nov. 15, 2014	Radiation (03CH01-CB)
Spectrum analyzer	R&S	FSP40	100979	9kHz~40GHz	Dec. 12, 2014	Conducted (TH01-CB)
Temp. and Humidity Chamber	Ten Billion	TTH-D3SP	TBN-931011	-30~100 degree	Jun. 02, 2015	Conducted (TH01-CB)
RF Cable-high	Woken	RG402	High Cable-7	1 GHz – 26.5 GHz	Nov. 15, 2014	Conducted (TH01-CB)
RF Cable-high	Woken	RG402	High Cable-8	1 GHz – 26.5 GHz	Nov. 15, 2014	Conducted (TH01-CB)
RF Cable-high	Woken	RG402	High Cable-9	1 GHz – 26.5 GHz	Nov. 15, 2014	Conducted (TH01-CB)
RF Cable-high	Woken	RG402	High Cable-10	1 GHz – 26.5 GHz	Nov. 15, 2014	Conducted (TH01-CB)
RF Cable-high	Woken	RG402	High Cable-6	1 GHz – 26.5 GHz	Nov. 15, 2014	Conducted (TH01-CB)
Power Sensor	Agilent	U2021XA	MY53410001	50MHz~18GHz	Nov. 03, 2014	Conducted (TH01-CB)

Note: Calibration Interval of instruments listed above is one year.

6. MEASUREMENT UNCERTAINTY

Test Items	Uncertainty	Remark
Radiated Emission (1GHz ~ 18GHz)	3.7 dB	Confidence levels of 95%
Radiated Emission (18GHz ~ 40GHz)	3.5 dB	Confidence levels of 95%
Conducted Emission	1.7 dB	Confidence levels of 95%

Appendix A. Test Photos

1. Photographs of Radiated Emissions Test Configuration

FRONT VIEW

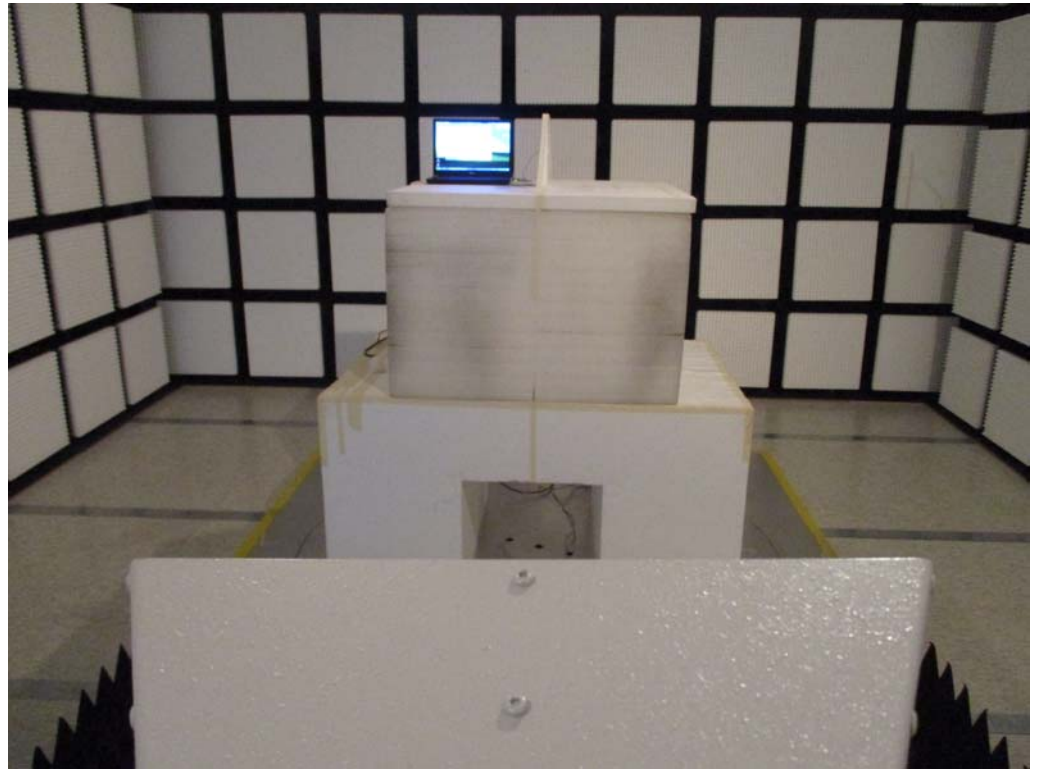

REAR VIEW

