



**FCC 47 CFR PART 15 SUBPART C AND ANSI C63.4:2003
TEST REPORT (Class II Permissive Change Report)**

For

802.11bgn WLAN + Bluetooth Mini Card

Model : BCM943227HMB

Trade Name : Broadcom

Issued for

BROADCOM CORPORATION

190 MATHILDA PLACE SUNNYVALE, CA 94086, U.S.A.

Issued by

**Compliance Certification Services Inc.
Hsinchu Lab.**

**NO. 989-1 Wen Shan Rd., Shang Shan Village,
Qionglin Shiang Hsinchu County 30741, Taiwan, R.O.C**

TEL: +886-3-5921698

FAX: +886-3-5921108

<http://www.ccsrf.com>

E-Mail : service@ccsrf.com

Issued Date: March 03, 2012



Note: *This report shall not be reproduced except in full, without the written approval of Compliance Certification Services Inc. This document may be altered or revised by Compliance Certification Services Inc. personnel only, and shall be noted in the revision section of the document. The client should not use it to claim product endorsement by TAF or any government agencies. The test results of this report relate only to the tested sample identified in this report.*



Revision History

Rev.	Issue Date	Revisions	Effect Page	Revised By
00	03/03/2012	Initial Issue	All Page 93	Winnie Chen



TABLE OF CONTENTS

TITLE	PAGE NO.
1. TEST REPORT CERTIFICATION	4
2. EUT DESCRIPTION	5
3. DESCRIPTION OF CLASS II CHANGE.....	6
4. DESCRIPTION OF TEST MODES	7-8
5. TEST METHODOLOGY	9
6. FACILITIES AND ACCREDITATION.....	9
6.1 FACILITIES	9
6.2 ACCREDITATIONS.....	9
6.3 MEASUREMENT UNCERTAINTY	10
7. SETUP OF EQUIPMENT UNDER TEST.....	11-12
8. FCC PART 15.247 REQUIREMENTS.....	13
8.1 MAXIMUM PEAK OUTPUT POWER (WIFI)	13-27
8.2 MAXIMUM PEAK OUTPUT POWER (BLUETOOTH)	28-29
8.3 AVERAGE POWER (WIFI).....	30-44
8.4 RADIATED EMISSION.....	45-92
APPENDIX SETUP PHOTOS	93



1. TEST REPORT CERTIFICATION

Applicant : BROADCOM CORPORATION
Address : 190 MATHILDA PLACE SUNNYVALE, CA 94086, U.S.A.
Equipment Under Test : 802.11bgn WLAN + Bluetooth Mini Card
Model : BCM943227HMB
Trade Name : Broadcom
Tested Date : February 14 ~ 29, 2012

APPLICABLE STANDARD	
Standard	Test Result
FCC Part 15 Subpart C AND ANSI C63.4:2003	PASS

WE HEREBY CERTIFY THAT: The above equipment has been tested by Compliance Certification Services Inc., and found compliance with the requirements set forth in the technical standards mentioned above. The results of testing in this report apply only to the product/system, which was tested. Other similar equipment will not necessarily produce the same results due to production tolerance and measurement uncertainties.

Approved by:

Rex Liao
Deputy Section Manager

Reviewed by:

Jacky Chen
Deputy Section Manager



2. EUT DESCRIPTION

Product Name	802.11bgn WLAN + Bluetooth Mini Card
Model Number	BCM943227HMB
Identify Number	T111230123
Received Date	February 14, 2012
Frequency Range	IEEE 802.11b/g, 802.11n HT20 : 2412MHz~2462MHz IEEE 802.11n HT40 : 2422MHz~2452MHz Bluetooth : 2402MHz ~ 2480MHz $f = 2402 + n\text{MHz}, n = 0, \dots, 78$
Transmit Power	Peak Power IEEE 802.11b : 21.54dBm (0.1426W) IEEE 802.11g : 24.69dBm (0.2944W) IEEE 802.11n HT20 : 24.92dBm (0.3102W) IEEE 802.11n HT40 : 24.26dBm (0.2665W) Bluetooth : 2.43dBm (0.0017W) Average Power IEEE 802.11b : 17.72dBm (0.0592W) IEEE 802.11g : 17.25dBm (0.0531W) IEEE 802.11n HT20 : 15.21dBm (0.0332W) IEEE 802.11n HT40 : 15.66dBm (0.0368W)
Channel Spacing	IEEE 802.11b/g, 802.11n HT20/HT40 : 5MHz Bluetooth : 1MHz
Channel Number	IEEE 802.11b/g, 802.11n HT20 : 11 Channels IEEE 802.11n HT40 : 7 Channels Bluetooth : 79 Channels
Transmit Data Rate	IEEE 802.11b : 11, 5.5, 2, 1 Mbps IEEE 802.11g : 54, 48, 36, 24, 18, 12, 9, 6 Mbps IEEE 802.11n HT20 : 144.44, 130, 117, 115.56, 104, 86.67, 78, 72.2, 65, 58.5, 57.78, 52, 43.33, 39, 28.89, 26, 21.7, 19.5, 14.44, 13, 7.2, 6.5 Mbps IEEE 802.11n HT40 : 300, 270, 243, 240, 216, 180, 162, 150, 135, 121.5, 120, 108, 90, 81, 60, 54, 45, 40.5, 30, 27, 15, 13.5Mbps Bluetooth : GFSK (1Mbps), $\pi/4$ -DQPSK (2Mbps), 8-DPSK (3Mbps)



Type of Modulation	IEEE 802.11b : DSSS (CCK, DQPSK, DBPSK) IEEE 802.11g : OFDM (64QAM, 16QAM, QPSK, BPSK) IEEE 802.11n HT20/40 : OFDM (64QAM, 16QAM, QPSK, BPSK) Bluetooth : Frequency Hopping Spread Spectrum
Frequency Selection	by software / firmware
Antenna Type	WiFi : PIFA Antenna, Antenna 1 (Chain 0) Gain 1.73dBi Antenna 2 (Chain 1) Gain -0.24dBi Bluetooth : PIFA Antenna, Antenna 2 (Chain 1) Gain -0.24dBi
Power Rating	20Vdc,4.5A (From Power Adapter)
Test Voltage	120Vac/60Hz
DC Power Cable Type	Non-shielded cable 1.8m (Non-detachable)
I/O Port	USB 2.0 Port x 2, RJ-45 Port x 1, HDMI Port x 1, USB 3.0 Port x 2, Audio In Port x 1, Audio Out Port x 1, SD Card Port x 1, VGA Port x 1, Power Port x 1

Power Adapter :

No.	Manufacturer	Model No.	Power Input	Power Output
1	lenovo	ADP-90DD B	100-240Vac, 50/60Hz, 1.5A	20Vdc, 4.5A

Remark :

1. The sample selected for test was engineering sample that approximated to production product and was provided by manufacturer.
2. For more details, please refer to the User's manual of the EUT.
3. This submittal(s) (test report) is intended for FCC ID: QDS-BRCM1060 filing to comply with Section 15.207, 15.209 and 15.247 of the FCC Part 15, Subpart C Rules.

3. DESCRIPTION OF CLASS II CHANGE

The major change filed under this application is:

Add portable condition compliance to the grant so that the module may be used in qualified host PC(s) and implementation of module-notebook authentication.

Product name: Notebook Computer

Brand name: lenovo

Model: 20152, 2617, Lenovo IdeaPad Z585

The above model numbers have the same specifications.



4. DESCRIPTION OF TEST MODES

The EUT is an 802.11n MIMO transceiver in 802.11bgn WLAN + Bluetooth Mini Card form factor. It has two transmitter chains and two receive chains (2x2 configurations). 11b/g mode, Chain 0 transmitter.

Radiated Emission Test (Below 1 GHz)

TX Mode

Conducted / Radiated Emission Test (Above 1 GHz)

IEEE 802.11b, 802.11g, 802.11n HT20 mode

The EUT had been tested under operating condition.

There are three channels have been tested as following :

Channel	Frequency (MHz)
Low	2412
Middle	2437
High	2462

IEEE 802.11b mode : 1Mbps data rate (worst case) were chosen for full testing.

IEEE 802.11g mode : 6Mbps data rate (worst case) were chosen for full testing.

IEEE 802.11n HT20 mode : 6.5Mbps data rate (worst case) were chosen for full testing.

IEEE 802.11n HT40 mode

The EUT had been tested under operating condition.

There are three channels have been tested as following :

Channel	Frequency (MHz)
Low	2422
Middle	2437
High	2452

IEEE 802.11n HT40 mode : 13.5Mbps data rate (worst case) were chosen for full testing.



Bluetooth

There are three channels have been tested as following :

Channel	Frequency (MHz)
Low	2402
Middle	2441
High	2480

Radiated Emission Test (Above 1 GHz):

Pre-Scan has been conducted to determine the worst-case mode from all possible combinations between available modulations, data rates and antenna ports (if EUT with antenna diversity architecture).

Following channel(s) was (were) selected for the final test as listed below.

Tested Channel	Modulation Technology	Modulation Type	Packet Type
Low, Mid, High	FHSS	GFSK	DH5
Low, Mid, High	FHSS	8-DPSK	3-DH5

Bandedge Measurement :

Pre-Scan has been conducted to determine the worst-case mode from all possible combinations between available modulations, data rates and antenna ports (if EUT with antenna diversity architecture).

Following channel(s) was (were) selected for the final test as listed below.

Tested Channel	Modulation Technology	Modulation Type	Packet Type
Low, High	FHSS	GFSK	DH5
Low, High	FHSS	8-DPSK	3-DH5

Antenna Port Conducted Measurement :

Pre-Scan has been conducted to determine the worst-case mode from all possible combinations between available modulations, data rates and antenna ports (if EUT with antenna diversity architecture).

Following channel(s) was (were) selected for the final test as listed below.

Tested Channel	Modulation Technology	Modulation Type	Packet Type
Low, Mid, High	FHSS	GFSK	DH5
Low, Mid, High	FHSS	8-DPSK	3-DH5



5. TEST METHODOLOGY

The tests documented in this report were performed in accordance with ANSI C63.4: 2003 and FCC CFR 47, 15.207, 15.209 and 15.247.

6. FACILITIES AND ACCREDITATION

6.1 FACILITIES

All measurement facilities used to collect the measurement data are located at

NO. 989-1 Wen Shan Rd., Shang Shan Village,
Qionglin Shiang Hsinchu County 30741, Taiwan, R.O.C

The sites are constructed in conformance with the requirements of ANSI C63.4:2003 and CISPR 22. All receiving equipment conforms to CISPR 16-1-1, CISPR 16-1-2, CISPR 16-1-3, CISPR 16-1-4, CISPR 16-1-5.

6.2 ACCREDITATIONS

Our laboratories are accredited and approved by the following approval agencies according to ISO/IEC 17025.

Taiwan	TAF
---------------	-----

The measuring facility of laboratories has been authorized or registered by the following approval agencies.

Canada	INDUSTRY CANADA
Japan	VCCI
Taiwan	BSMI
USA	FCC MRA

Copies of granted accreditation certificates are available for downloading from our web site, <http://www.ccsrf.com>



6.3 MEASUREMENT UNCERTAINTY

The following table is for the measurement uncertainty, which is calculated as per the document CISPR 16-4-2.

PARAMETER	UNCERTAINTY
Semi Anechoic Chamber (966 Chamber_A) / Radiated Emission, 30 to 1000 MHz	+/- 3.0371
Semi Anechoic Chamber (966 Chamber_A) / Radiated Emission, 1 to 18GHz	+/- 2.5258
Semi Anechoic Chamber (966 Chamber_A) / Radiated Emission, 18 to 26 GHz	+/- 2.5012
Semi Anechoic Chamber (966 Chamber_A) / Radiated Emission, 26 to 40 GHz	+/- 2.7846

This uncertainty represents an expanded uncertainty expressed at approximately the 95% confidence level using a coverage factor of $k=2$.

Consistent with industry standard (e.g. CISPR 22: 2006, clause 11, Measurement Uncertainty) determining compliance with the limits shall be base on the results of the compliance measurement. Consequently the measure emissions being less than the maximum allowed emission result in this be a compliant test or passing test.

The acceptable measurement uncertainty value without requiring revision of the compliance statement is base on conducted and radiated emissions being less than U_{CISPR} which is 3.6dB and 5.2dB respectively. CCS values (called U_{Lab} in CISPR 16-4-2) is less than U_{CISPR} as shown in the table above. Therefore, MU need not be considered for compliance.



7. SETUP OF EQUIPMENT UNDER TEST

SUPPORT EQUIPMENT

N/A

SETUP DIAGRAM FOR TESTS

EUT & peripherals setup diagram is shown in appendix setup photos.

EUT OPERATING CONDITION

WiFi

1. Setup all computers like the setup diagram.
2. Run Test software..
3. Select the following settings
4. net stop wlansvc
timeout 1
net start wlansvc
timeout 4
wl out
wl up
wl antdiv 0
wl txant 0
wl mpc 0
wl frameburst 1
wl down
wl ampdu 1
wl country ALL
wl band b
wl up
wl chanspec -c 1 -b 2 -w 20 -s 0
timeout 4
wl wsec 0
timeout 4
wl join testb imode adhoc
timeout 4
wl legacylink
timeout 6
wl nrate -r 1
wl cck_txbw 2
wl txpwr1 -o -q 75
timeout 4
epi_tcp -tsuHfm -l 8760 -n 10000000 192.168.66.255
6. All of the functions are under run.
7. Start test.



Bluetooth

1. Setup all computers like the setup diagram.
2. Run BlueTool Test software.
3. Select the following settings
4. TX mode(GFSK)

0: Vendor-specific Commands (0 key)

TX_Test

Hopping_Mode: Single frequency

Frequency: 2402, 2441, 2480

Modulation_Type: PRES9 Pattern

Logical_Channel: ACL Basic

BB_Packet_Type: DH5 / 3-DH5

BB_Packet_Length: 339

Tx_Power_Level: 0dBm

TX mode(8-DPSK)

0: Vendor-specific Commands (0 key)

TX_Test

Hopping_Mode: Single frequency

Frequency: 2402, 2441, 2480

Modulation_Type: PRES9 Pattern

Logical_Channel: ACL EDR

BB_Packet_Type: DH5 / 3-DH5

BB_Packet_Length: 1021

Tx_Power_Level: 0dBm

5. All of the functions are under run.
6. Start test.



8. FCC PART 15.247 REQUIREMENTS

8.1 MAXIMUM PEAK OUTPUT POWER (WIFI)

LIMITS

§ 15.247(b) The maximum peak output power of the intentional radiator shall not exceed the following :

§ 15.247(b) (3) For systems using digital modulation in the 902-928 MHz, 2400-2483.5 MHz, and 5725-5850 MHz bands : 1 watt.

§ 15.247(b) (4) Except as shown in paragraphs (c) of this section, if transmitting antennas of directional gain greater than 6 dBi are used the peak output power from the intentional radiator shall be reduced below the stated values in paragraphs (b)(1) or (b)(2), and (b)(3) of this section, as appropriate, by the amount in dB that the directional gain of the antenna exceeds 6 dBi.

TEST EQUIPMENT

Name of Equipment	Manufacturer	Model	Serial Number	Calibration Due
Spectrum Analyzer	Agilent	E4407B	US41443108	08/09/2012

Remark: Each piece of equipment is scheduled for calibration once a year.

TEST SETUP

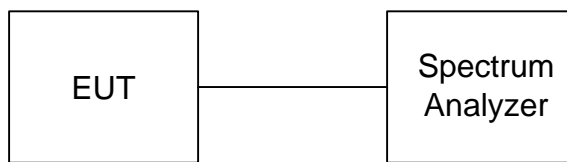

TEST PROCEDURE

- The spectrum shall be set as follows :
 - Span : 1.5 times channel integration bandwidth.
 - RBW : 1MHz
 - VBW : 3MHz
 - Detector : Peak
 - Sweep : Single trace
- Compute the combined power of all signal responses contained in the trace by covering all the data points.
- The peak output power is the channel power integrated over 26dB bandwidth.



TEST RESULTS

IEEE 802.11b Mode

Channel	Channel Frequency (MHz)	Peak Power		Peak Power Limit		Pass / Fail
		(dBm)	(W)	(dBm)	(W)	
Low	2412	21.11	0.1291	30	1	PASS
Middle	2437	21.54	0.1426	30	1	PASS
High	2462	20.21	0.1050	30	1	PASS

Remark:

1. At final test to get the worst-case emission at 1Mbps.
2. The cable assembly insertion loss of 11.5dB (including 10 dB pad and 1.5 dB cable) was Entered as an offset in the spectrum analyzer to allow for direct reading of power.
3. The maximum antenna gain is 3.87dBi which is less than 6dBi, the limit should be 1W.

IEEE 802.11g Mode

Channel	Channel Frequency (MHz)	Peak Power		Peak Power Limit		Pass / Fail
		(dBm)	(W)	(dBm)	(W)	
Low	2412	20.81	0.1205	30	1	PASS
Middle	2437	24.69	0.2944	30	1	PASS
High	2462	20.41	0.1099	30	1	PASS

Remark:

1. At final test to get the worst-case emission at 1Mbps.
2. The cable assembly insertion loss of 11.5dB (including 10 dB pad and 1.5 dB cable) was Entered as an offset in the spectrum analyzer to allow for direct reading of power.
3. The maximum antenna gain is 3.87dBi which is less than 6dBi, the limit should be 1W.



IEEE 802.11n HT20 Mode (Two TX)

Channel	Channel Frequency (MHz)	Peak Power (dBm)		Peak Power Total		Peak Power Limit		Pass / Fail
		Chain 0	Chain 1	(dBm)	(W)	(dBm)	(W)	
Low	2412	21.88	20.39	24.21	0.2636	30	1	PASS
Middle	2437	22.14	21.66	24.92	0.3102	30	1	PASS
High	2462	20.82	20.77	23.81	0.2402	30	1	PASS

Remark:

1. At final test to get the worst-case emission at 6.5Mbps.
2. The cable assembly insertion loss of 11.5dB (including 10 dB pad and 1.5 dB cable) was Entered as an offset in the spectrum analyzer to allow for direct reading of power.
3. Total peak power = Chain 0 + Chain 1.
4. The maximum antenna gain is 3.87dBi which is less than 6dBi, the limit should be 1W.

IEEE 802.11n HT40 Mode (Two TX)

Channel	Channel Frequency (MHz)	Peak Power (dBm)		Peak Power Total		Peak Power Limit		Pass / Fail
		Chain 0	Chain 1	(dBm)	(W)	(dBm)	(W)	
Low	2422	20.26	20.78	23.54	0.2258	30	1	PASS
Middle	2437	21.56	20.45	24.05	0.2541	30	1	PASS
High	2452	21.47	21.01	24.26	0.2665	30	1	PASS

Remark:

1. At final test to get the worst-case emission at 6.5Mbps.
2. The cable assembly insertion loss of 11.5dB (including 10 dB pad and 1.5 dB cable) was Entered as an offset in the spectrum analyzer to allow for direct reading of power.
3. Total peak power = Chain 0 + Chain 1.
4. The maximum antenna gain is 3.87dBi which is less than 6dBi, the limit should be 1W.



MAXIMUM PEAK OUTPUT POWER

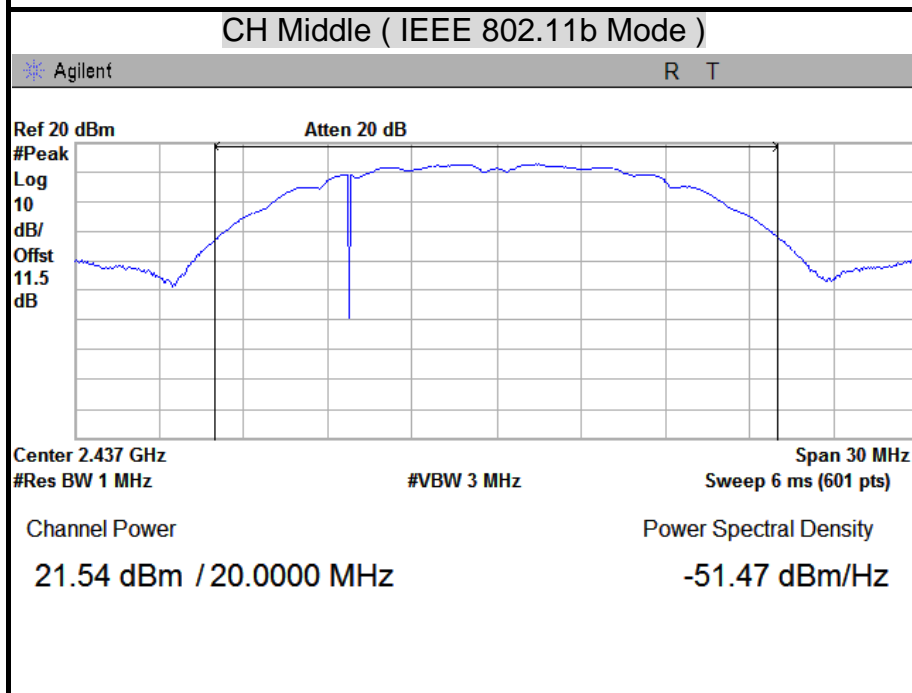
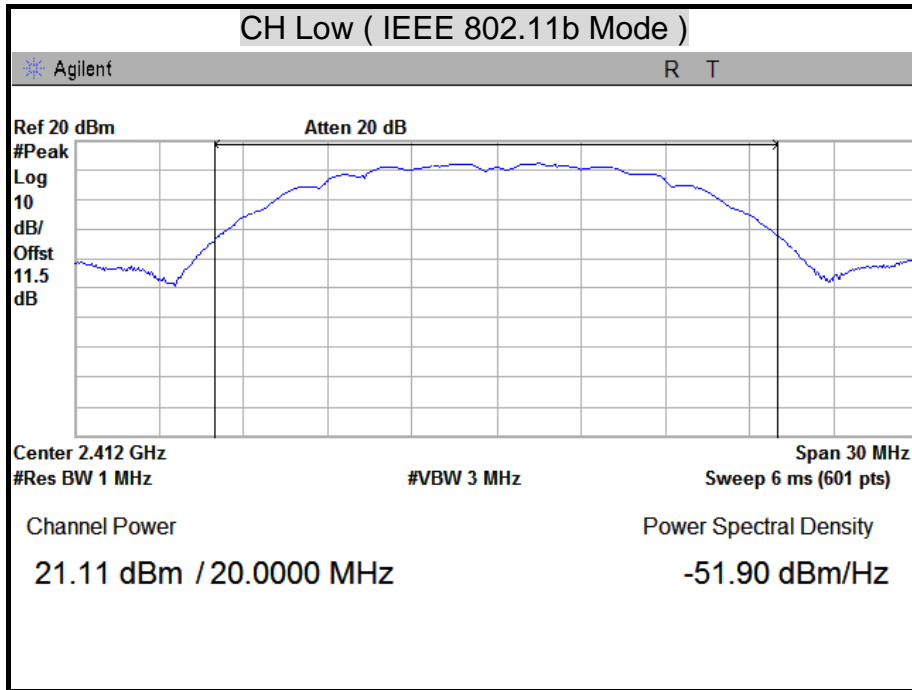

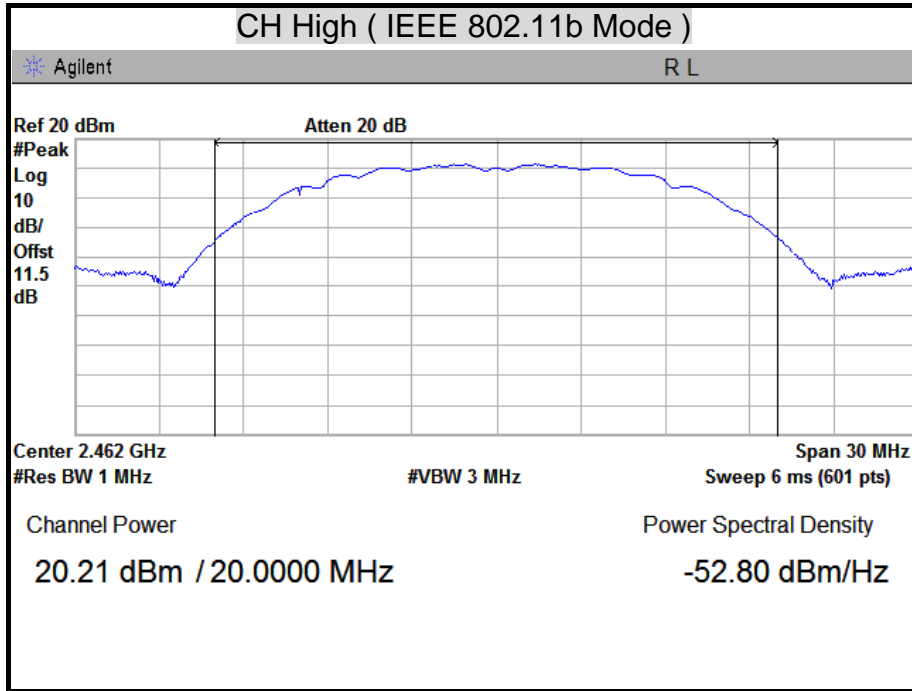

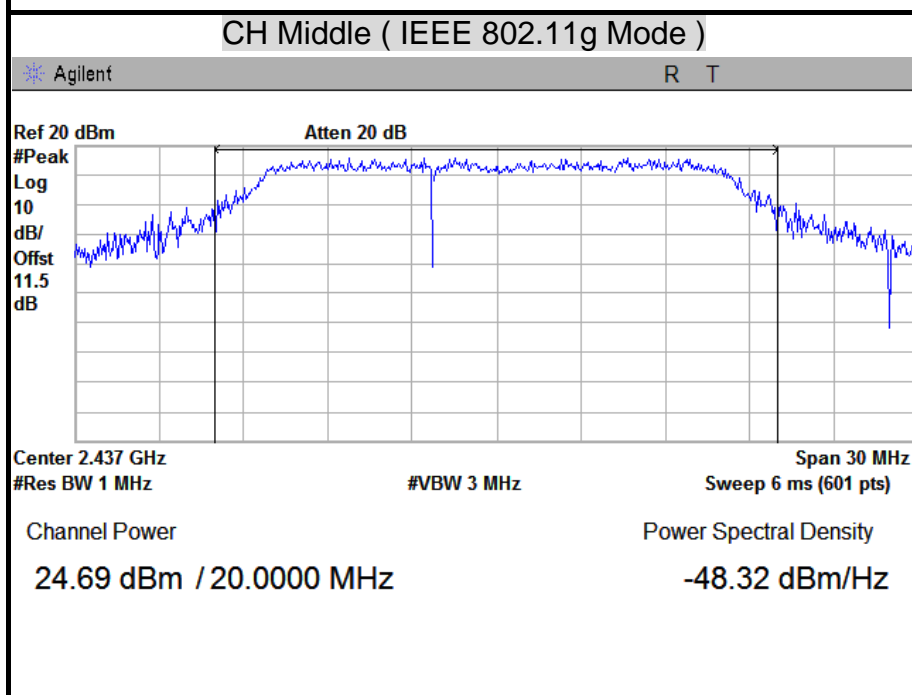
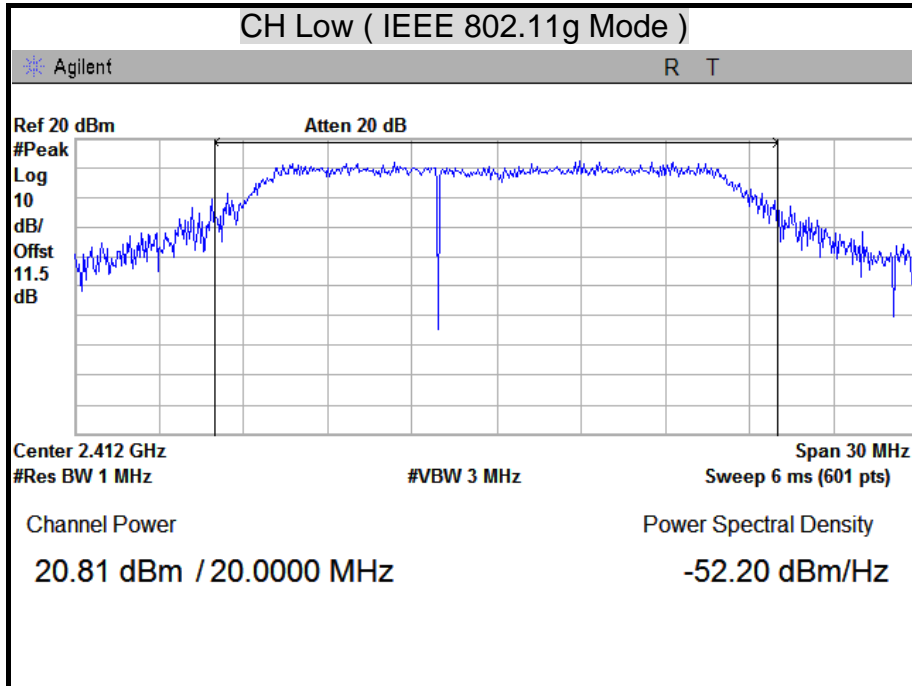

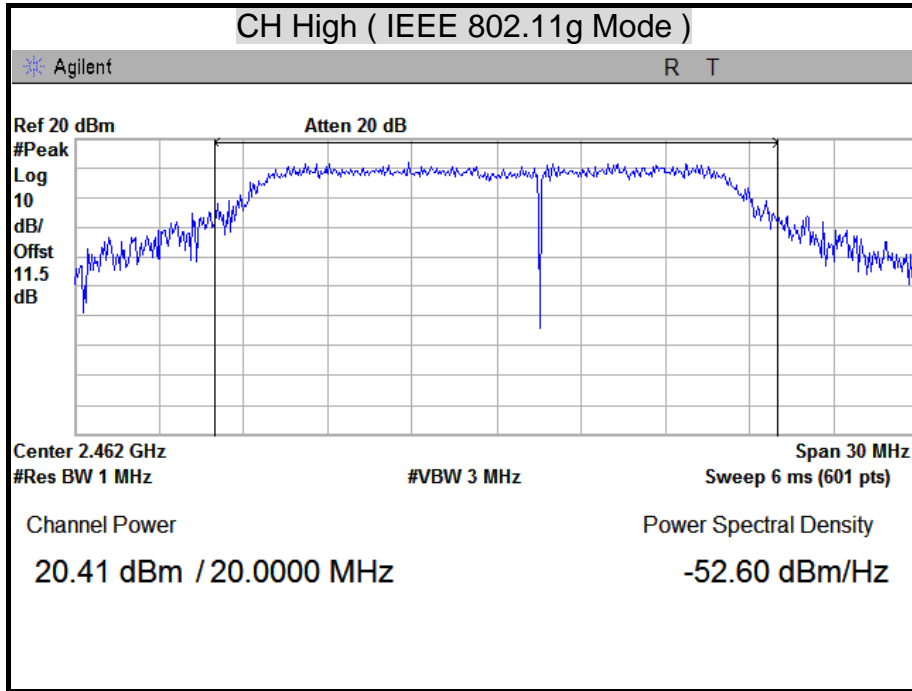

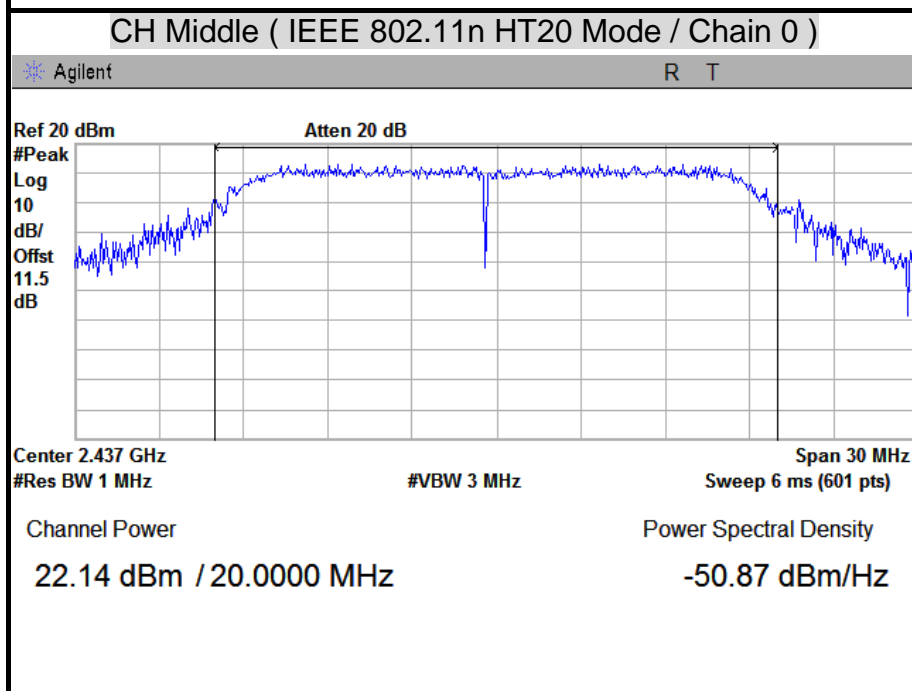
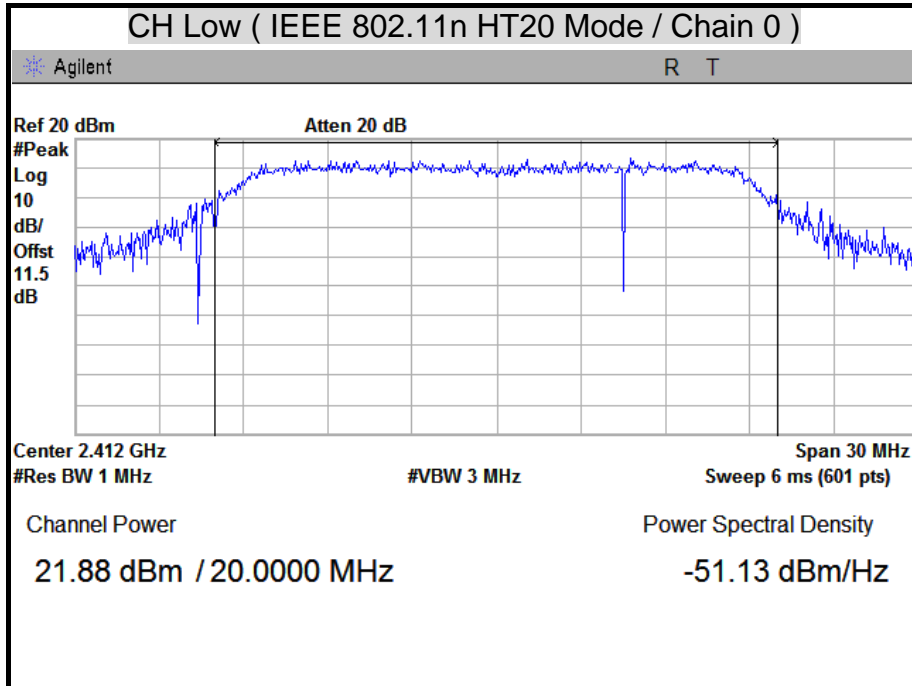

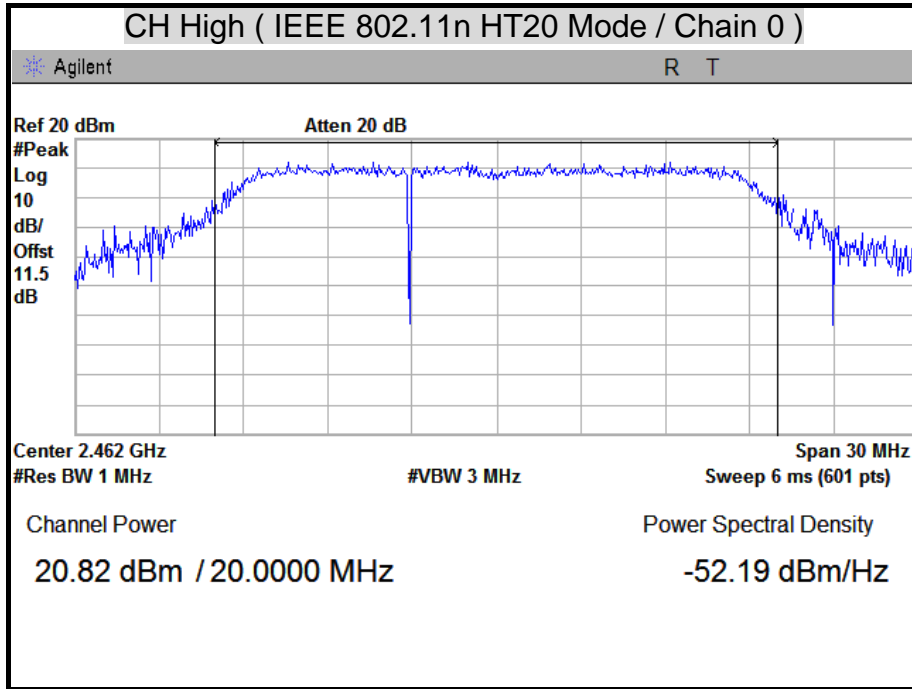

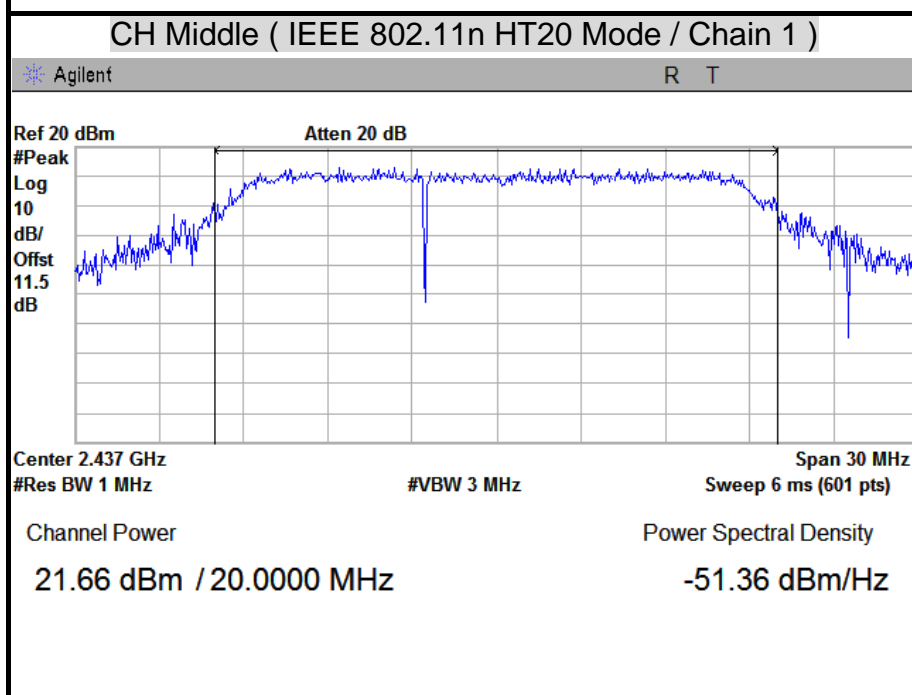
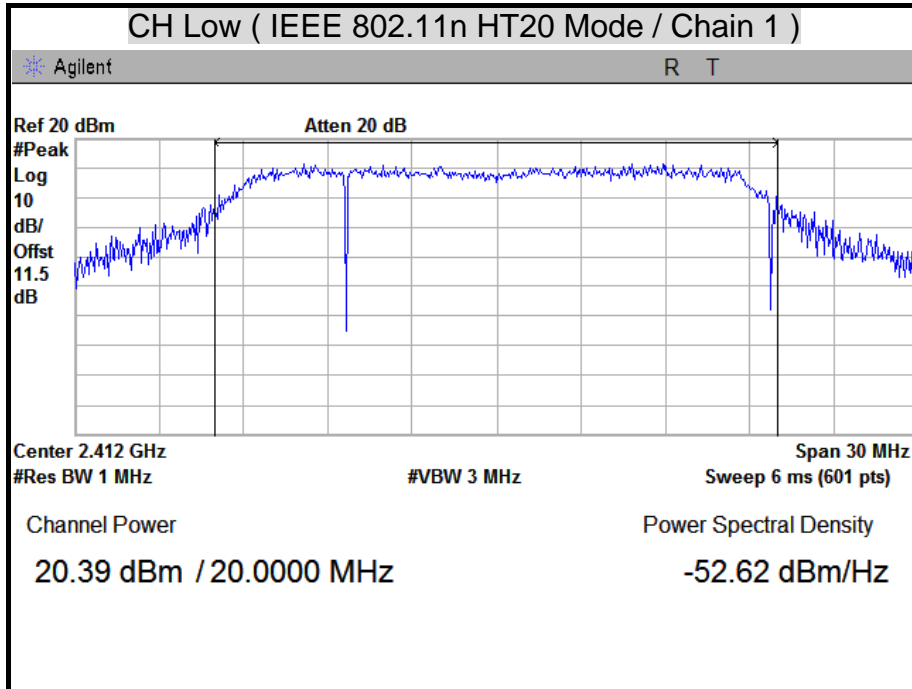

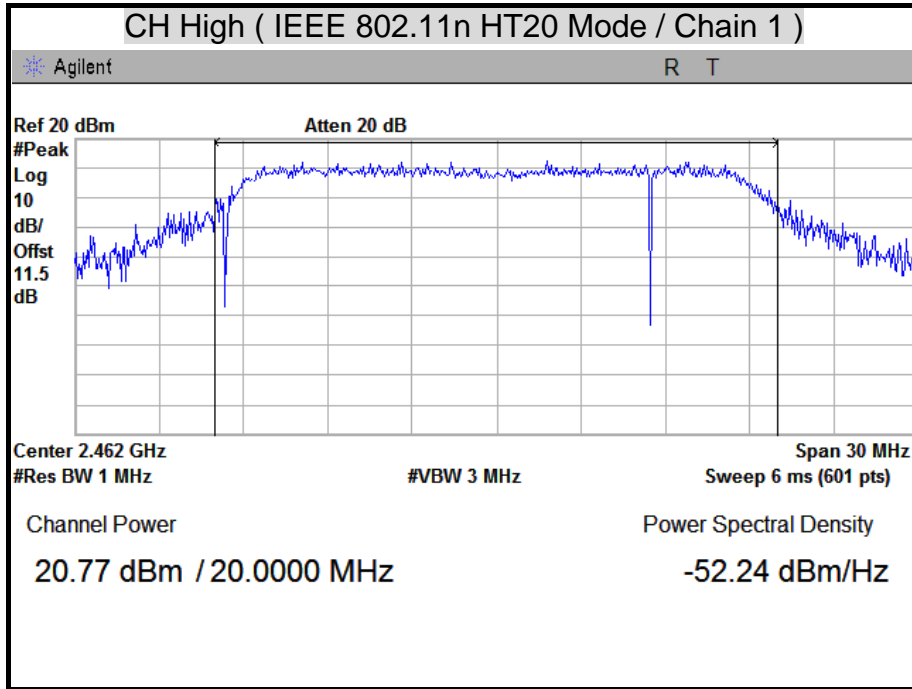

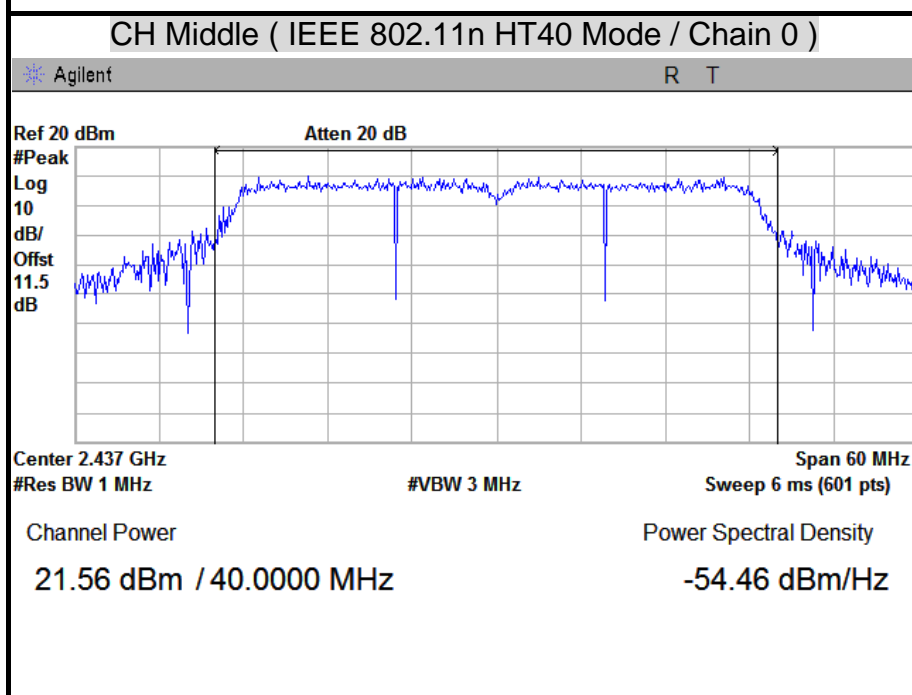
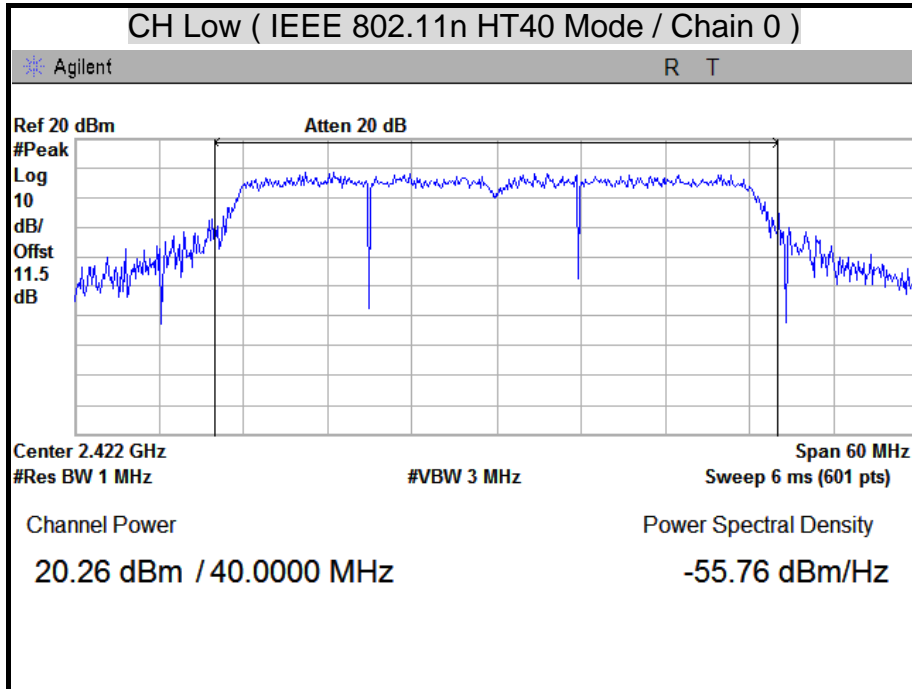

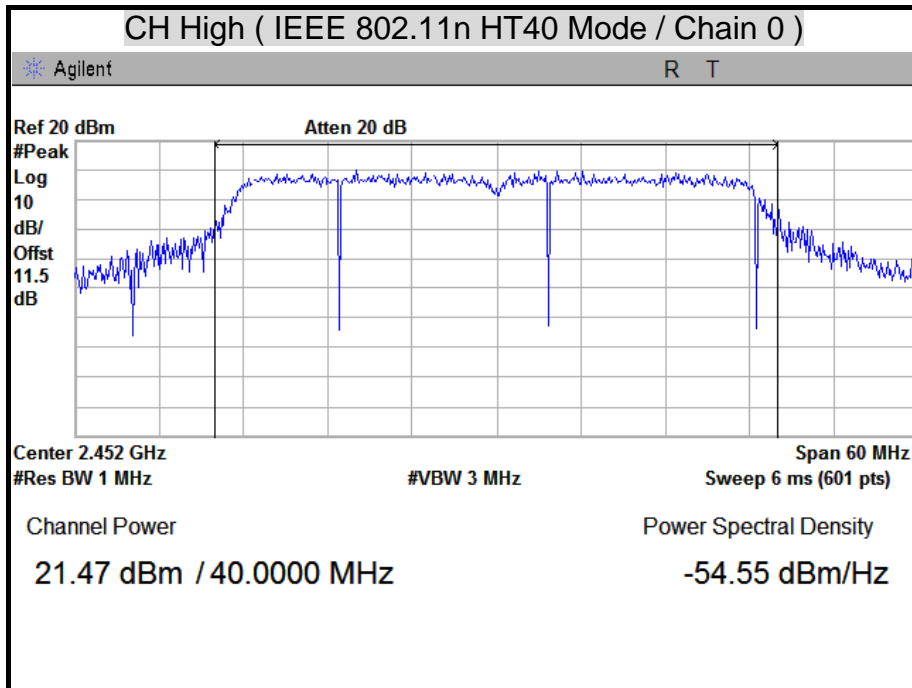

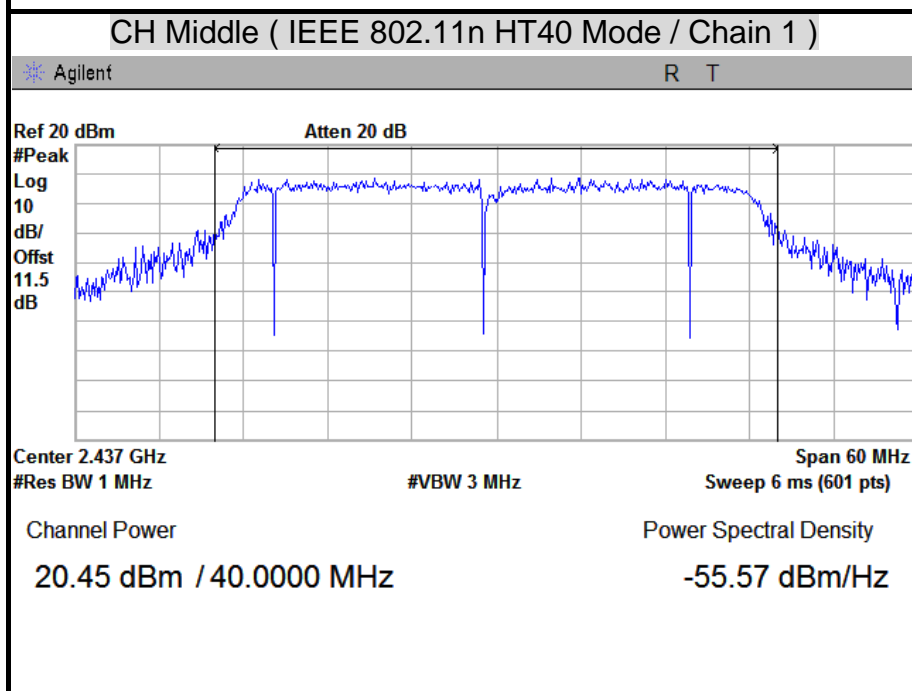
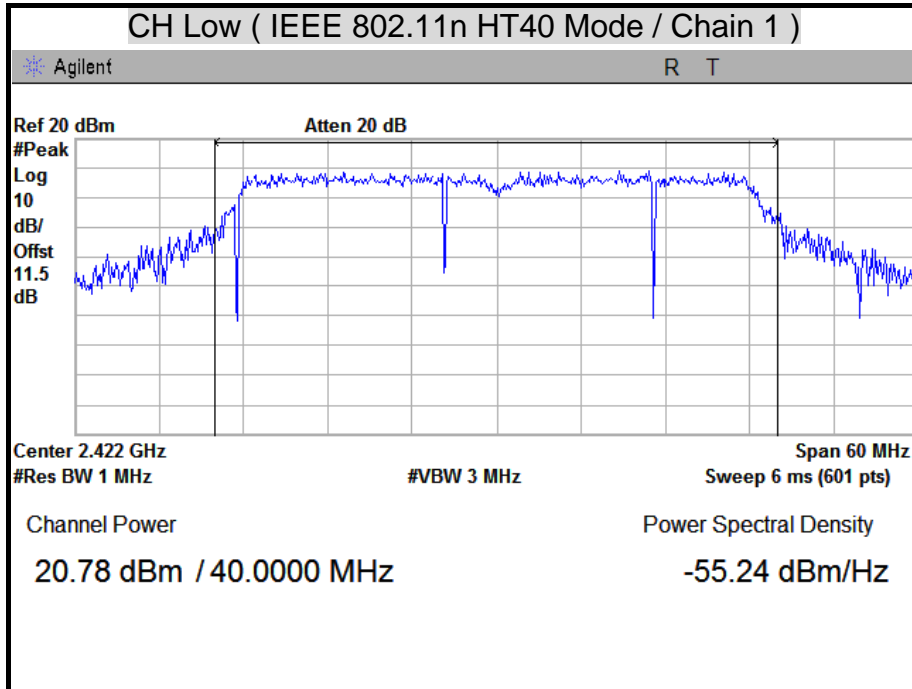

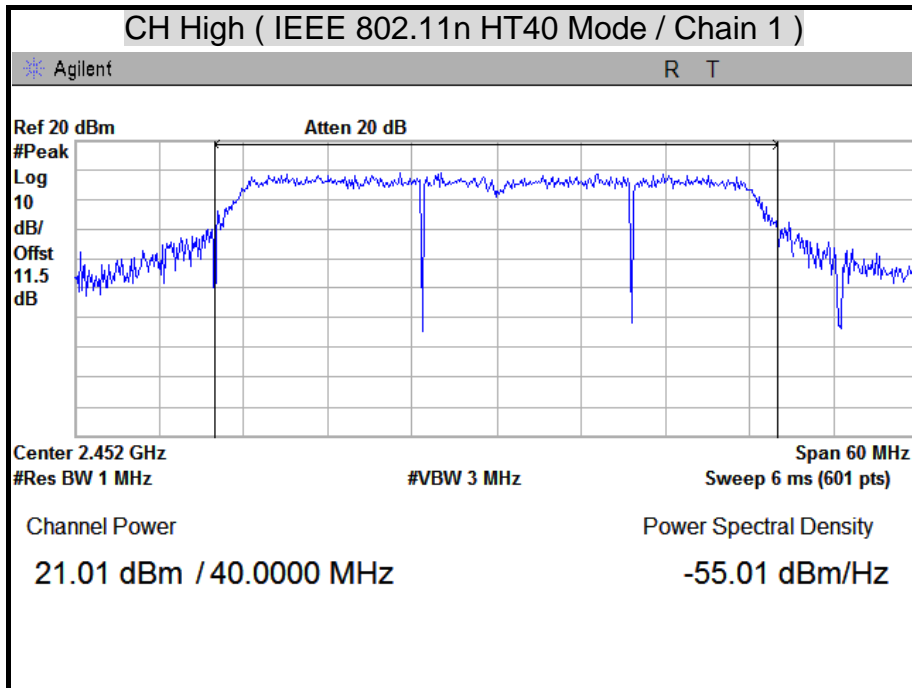



8.2 MAXIMUM PEAK OUTPUT POWER (BLUETOOTH)

LIMITS

§15.247(b)(1) For frequency hopping systems operating in the 2400-2483.5 MHz band employing at least 75 non-overlapping hopping channels, and all frequency hopping systems in the 5725-5850 MHz band: 1 watt. For all other frequency hopping systems in the 2400-2483.5 MHz band: 0.125 watts.

TEST EQUIPMENT

Name of Equipment	Manufacturer	Model	Serial Number	Calibration Due
Wideband Peak Power Meter	Anritsu	ML2487A	6K00001783	04/18/2012
Wide Bandwidth Sensor	Anritsu	MA2491A	030982	04/18/2012

Remark: Each piece of equipment is scheduled for calibration once a year.

TEST SETUP

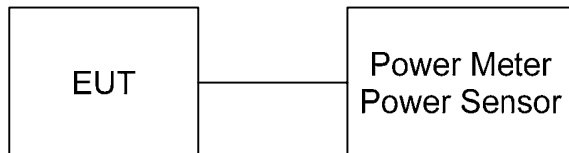

TEST PROCEDURE

The RF power output was measured with a power meter connected to the RF Antenna connector (conducted measurement) while EUT was operating in transmit mode at the appropriate center frequency, a power meter was used to record the shape of the transmit signal.



TEST RESULTS

Modulation Type: GFSK, CFG PKT Packet Type: 15 Packet Size: 339 (DH5)

Channel	Channel Frequency (MHz)	Peak Power		Peak Power Limit		Result
		(dBm)	(W)	(dBm)	(W)	
Low	2402	0.36	0.0011	20.97	0.125	PASS
Middle	2441	1.04	0.0013	20.97	0.125	PASS
High	2480	1.56	0.0014	20.97	0.125	PASS

Remark: The cable assembly insertion loss of 11.5dB (including 10 dB pad and 1.5 dB cable) was Entered as an offset in the power meter to allow for direct reading of power.

Modulation Type: 8-DPSK, CFG PKT Packet Type: 31 Packet Size: 1021 (3-DH5)

Channel	Channel Frequency (MHz)	Peak Power		Peak Power Limit		Result
		(dBm)	(W)	(dBm)	(W)	
Low	2402	1.62	0.0015	20.97	0.125	PASS
Middle	2441	2.25	0.0017	20.97	0.125	PASS
High	2480	2.43	0.0017	20.97	0.125	PASS

Remark: The cable assembly insertion loss of 11.5dB (including 10 dB pad and 1.5 dB cable) was Entered as an offset in the power meter to allow for direct reading of power.



8.3 AVERAGE POWER (WIFI)

LIMITS

§ 15.247(b) The maximum peak output power of the intentional radiator shall not exceed the following :

§ 15.247(b) (3) For systems using digital modulation in the 902-928 MHz, 2400-2483.5 MHz, and 5725-5850 MHz bands : 1 watt.

§ 15.247(b) (4) Except as shown in paragraphs (c) of this section, if transmitting antennas of directional gain greater than 6 dBi are used the peak output power from the intentional radiator shall be reduced below the stated values in paragraphs (b)(1) or (b)(2), and (b)(3) of this section, as appropriate, by the amount in dB that the directional gain of the antenna exceeds 6 dBi.

TEST EQUIPMENT

Table with 5 columns: Name of Equipment, Manufacturer, Model, Serial Number, Calibration Due. Row 1: Spectrum Analyzer, Agilent, E4407B, US41443108, 08/09/2012

Remark: Each piece of equipment is scheduled for calibration once a year.

TEST SETUP



TEST PROCEDURE

- 1. The spectrum shall be set as follows : Span : 1.5 times channel integration bandwidth. RBW : 1MHz VBW : 3MHz Detector : Sample Sweep : 100 traces
2. Compute the combined power of all signal responses contained in the trace by covering all the data points.
3. The output power is the channel power integrated over EBW.



TEST RESULTS

IEEE 802.11b Mode

Channel	Channel Frequency (MHz)	Average Power		Pass / Fail
		(dBm)	(W)	
Low	2412	17.64	0.0581	PASS
Middle	2437	17.72	0.0592	PASS
High	2462	16.20	0.0417	PASS

Remark:

1. At final test to get the worst-case emission at 1Mbps.
2. The cable assembly insertion loss of 11.5dB (including 10 dB pad and 1.5 dB cable) was Entered as an offset in the spectrum analyzer to allow for direct reading of power.
3. The maximum antenna gain is 3.87dBi which is less than 6dBi, the limit should be 1W.

IEEE 802.11g Mode

Channel	Channel Frequency (MHz)	Average Power		Pass / Fail
		(dBm)	(W)	
Low	2412	11.65	0.0146	PASS
Middle	2437	17.25	0.0531	PASS
High	2462	11.34	0.0136	PASS

Remark:

1. At final test to get the worst-case emission at 1Mbps.
2. The cable assembly insertion loss of 11.5dB (including 10 dB pad and 1.5 dB cable) was Entered as an offset in the spectrum analyzer to allow for direct reading of power.
3. The maximum antenna gain is 3.87dBi which is less than 6dBi, the limit should be 1W.



IEEE 802.11n HT20 Mode (Two TX)

Channel	Channel Frequency (MHz)	Average Power (dBm)		Average Power Total		Pass / Fail
		Chain 0	Chain 1	(dBm)	(W)	
Low	2412	11.44	11.34	14.40	0.0275	PASS
Middle	2437	12.23	11.58	14.93	0.0311	PASS
High	2462	12.48	11.90	15.21	0.0332	PASS

Remark:

1. At final test to get the worst-case emission at 6.5Mbps.
2. The cable assembly insertion loss of 11.5dB (including 10 dB pad and 1.5 dB cable) was Entered as an offset in the spectrum analyzer to allow for direct reading of power.
3. Total power = Chain 0 + Chain 1.
4. The maximum antenna gain is 3.87dBi which is less than 6dBi, the limit should be 1W.

IEEE 802.11n HT40 Mode (Two TX)

Channel	Channel Frequency (MHz)	Average Power (dBm)		Average Power Total		Pass / Fail
		Chain 0	Chain 1	(dBm)	(W)	
Low	2422	12.10	11.98	15.05	0.0320	PASS
Middle	2437	12.86	12.42	15.66	0.0368	PASS
High	2452	11.65	11.62	14.65	0.0291	PASS

Remark:

1. At final test to get the worst-case emission at 6.5Mbps.
2. The cable assembly insertion loss of 11.5dB (including 10 dB pad and 1.5 dB cable) was Entered as an offset in the spectrum analyzer to allow for direct reading of power.
3. Total power = Chain 0 + Chain 1.
4. The maximum antenna gain is 3.87dBi which is less than 6dBi, the limit should be 1W.



AVERAGE POWER

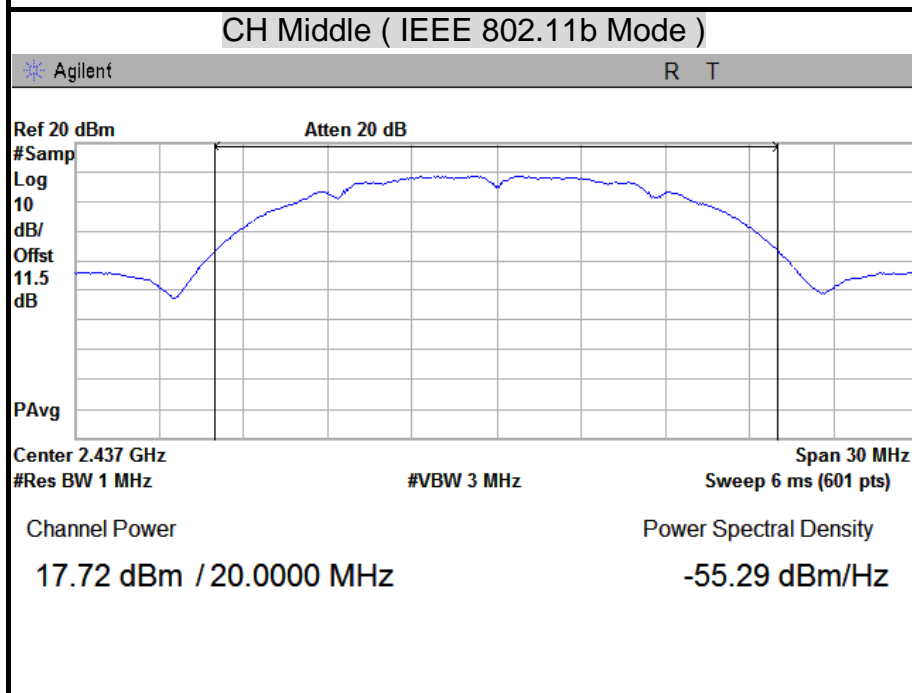
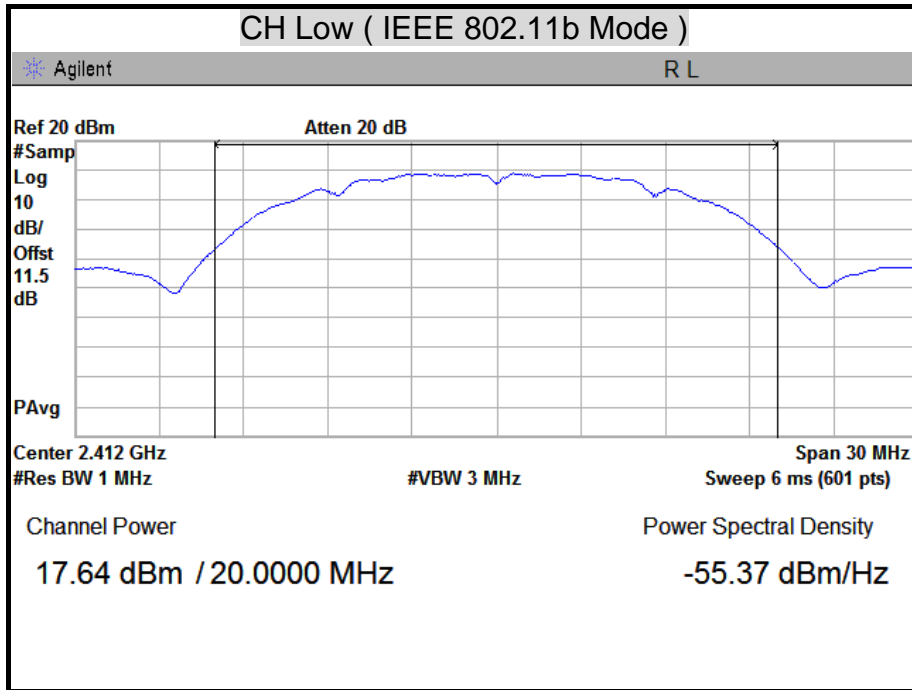

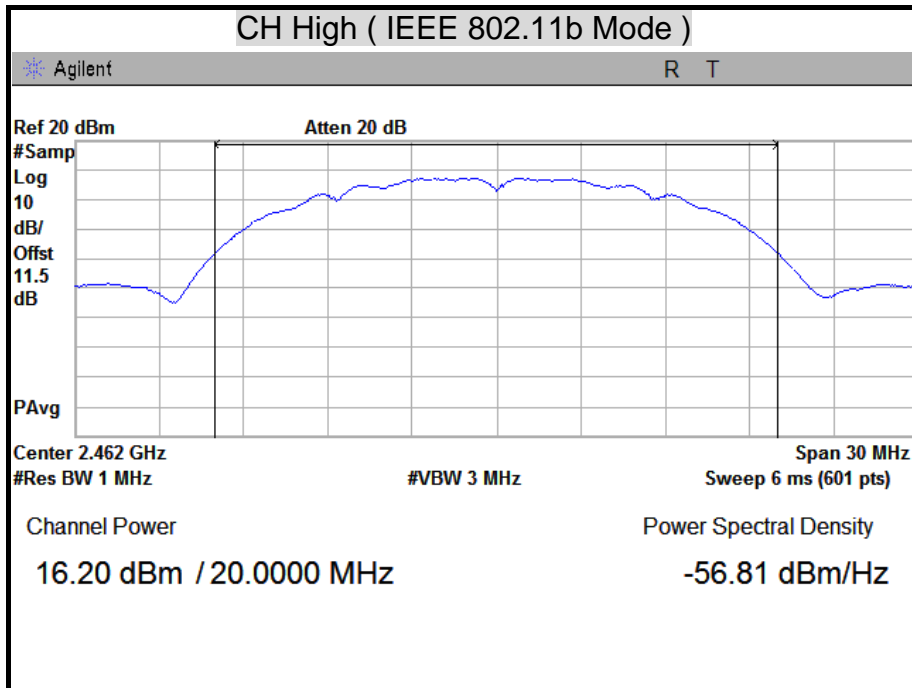

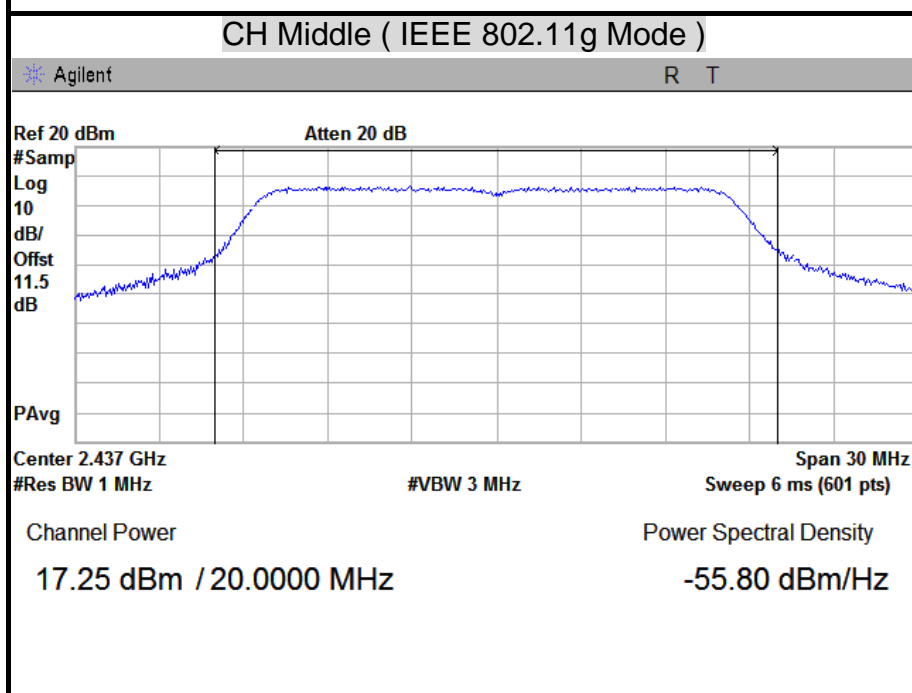
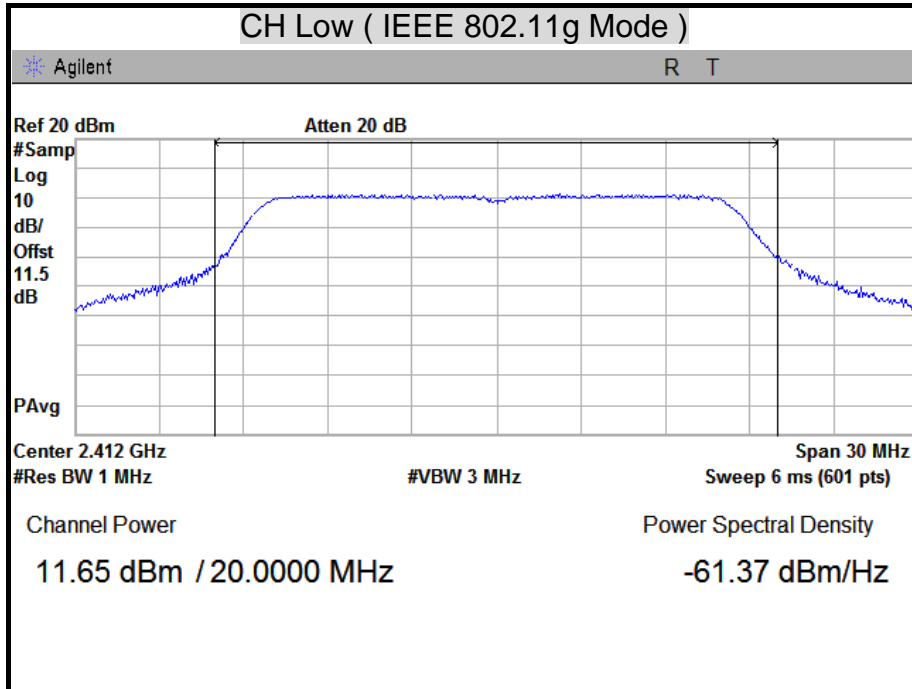

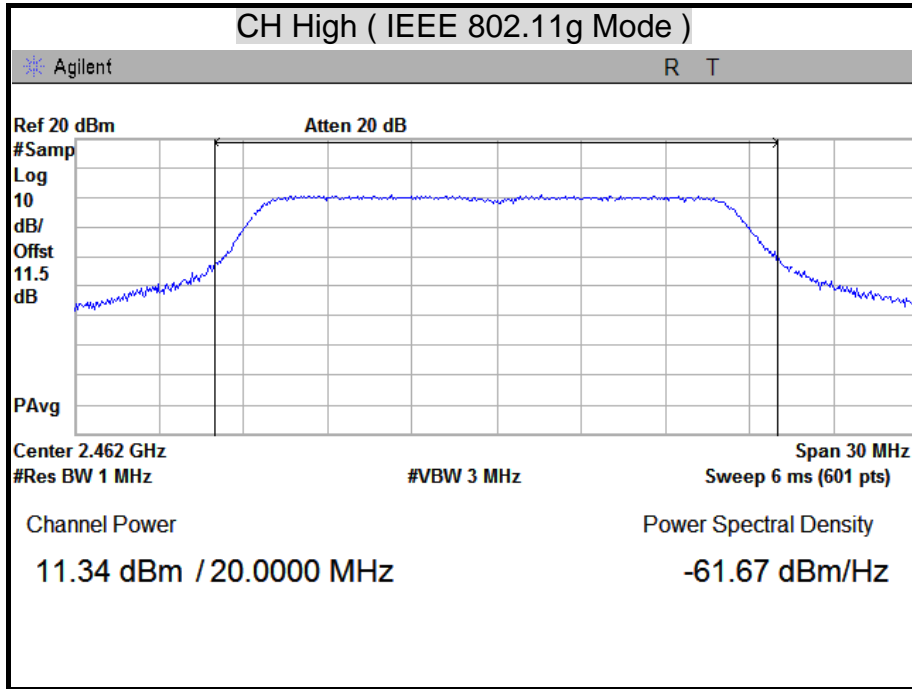

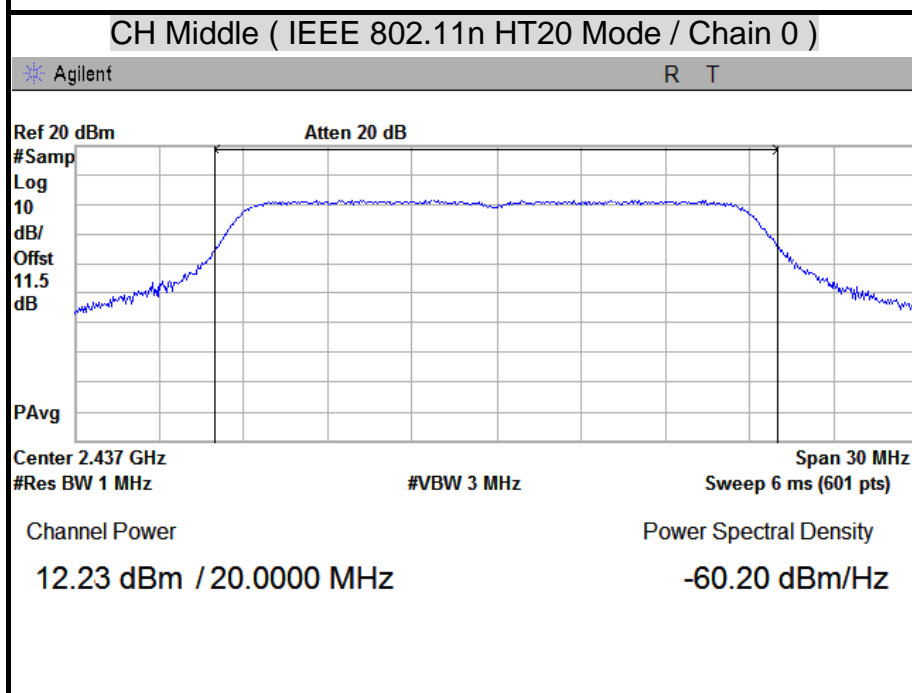
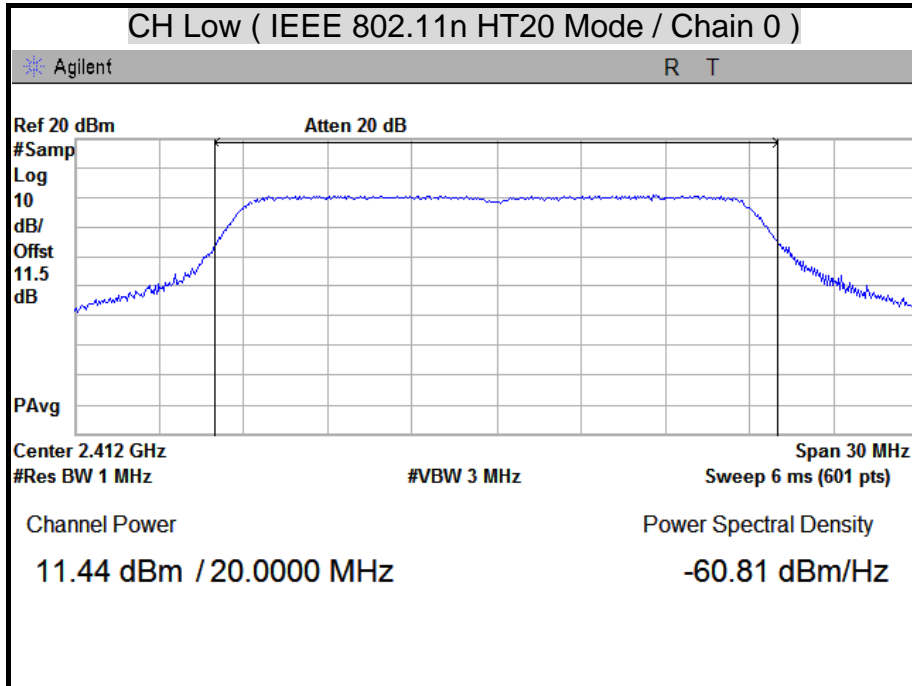

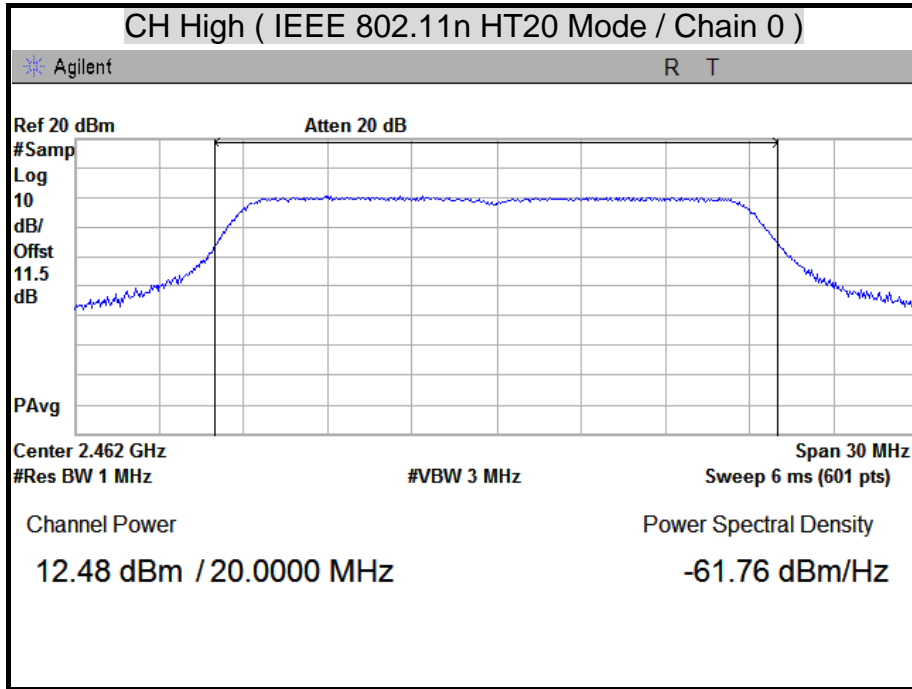

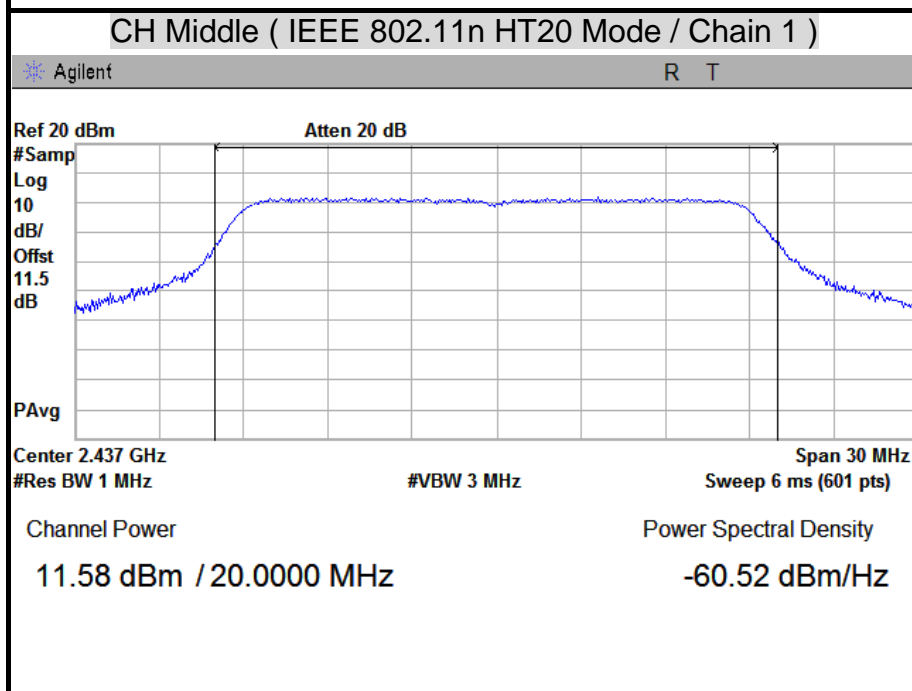
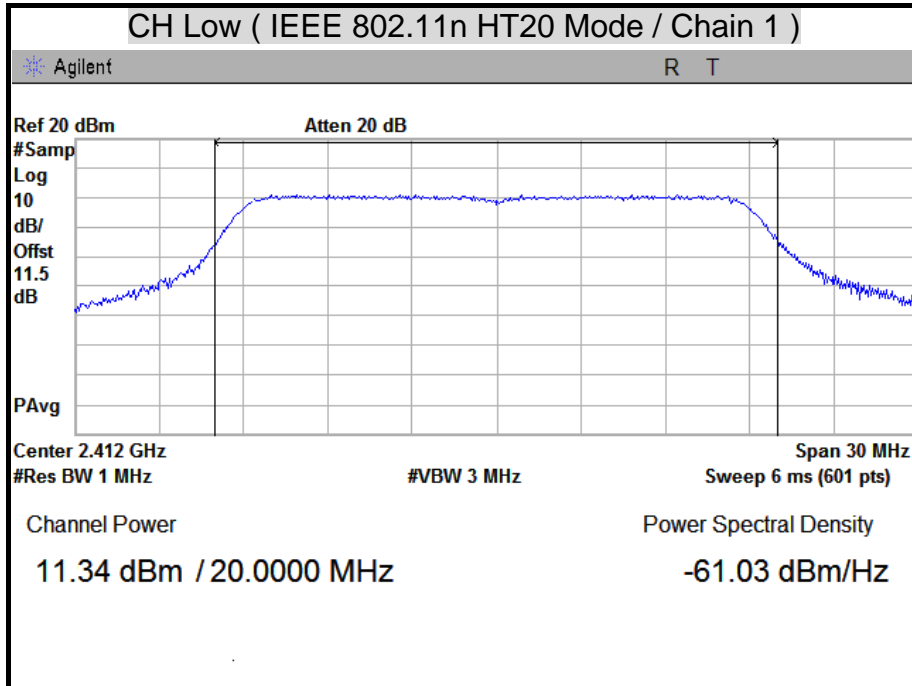

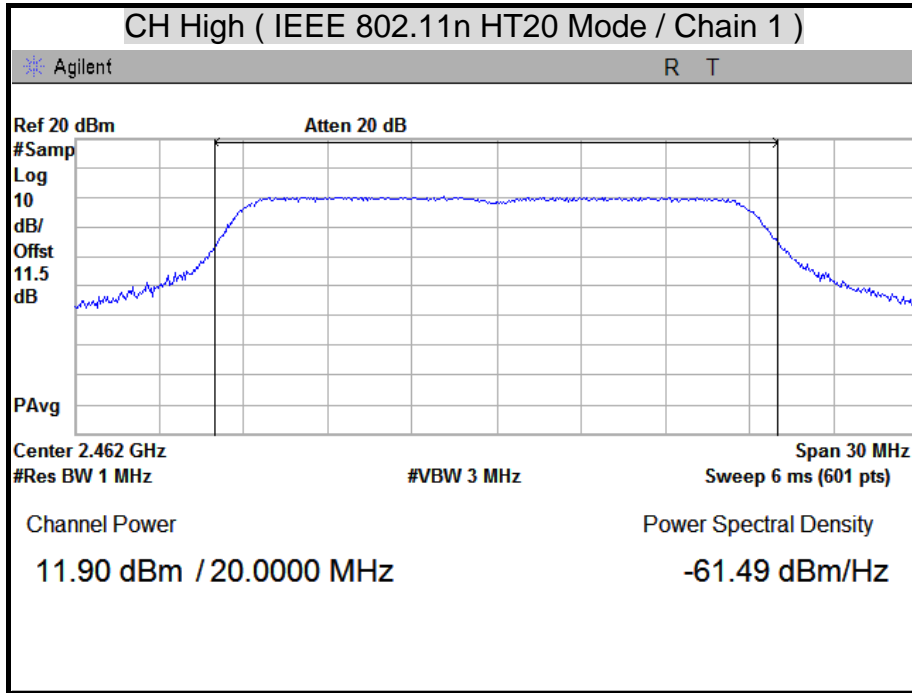

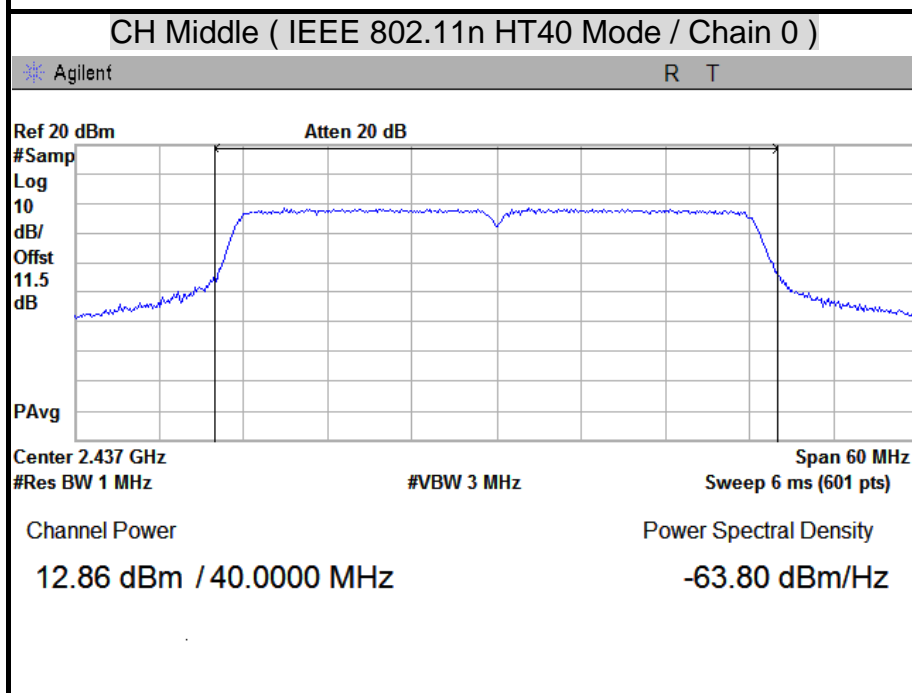
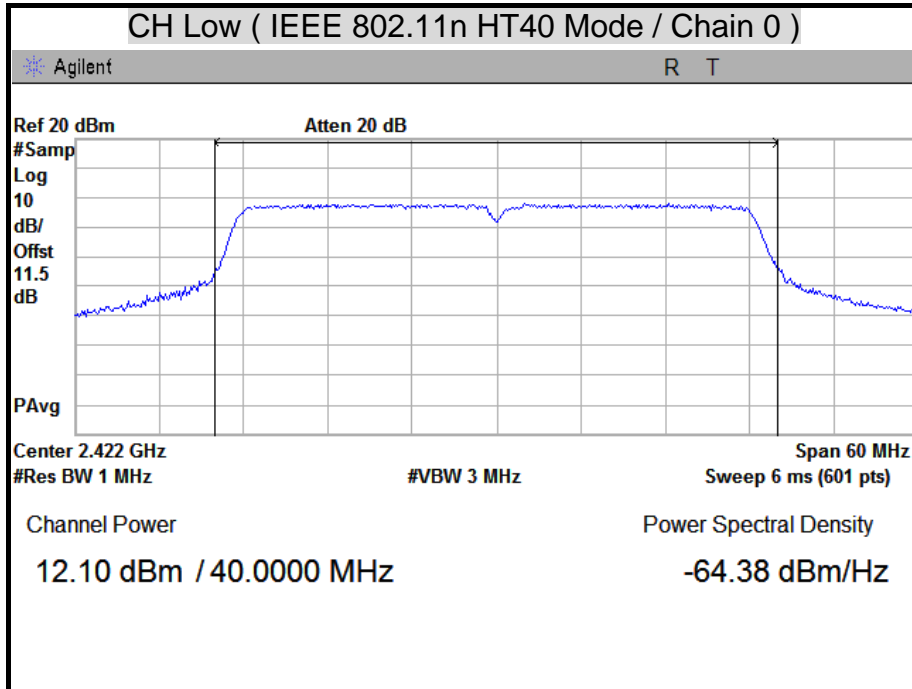

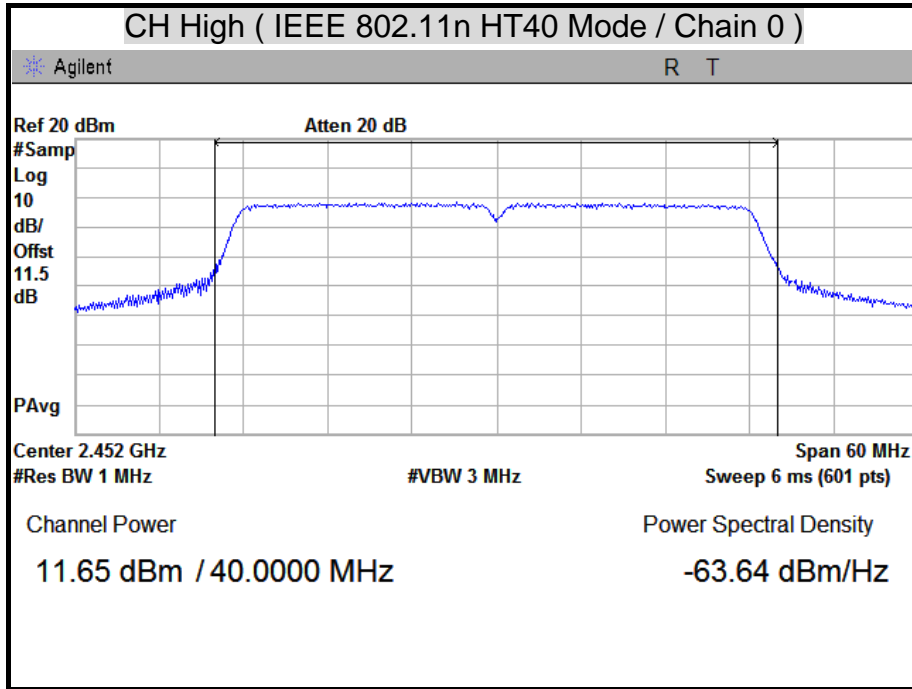

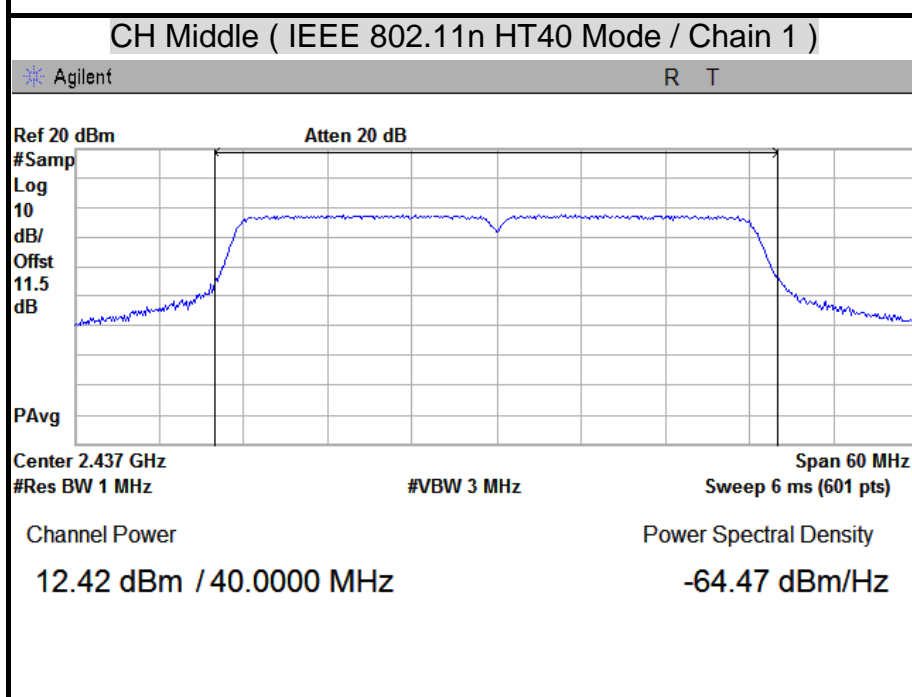
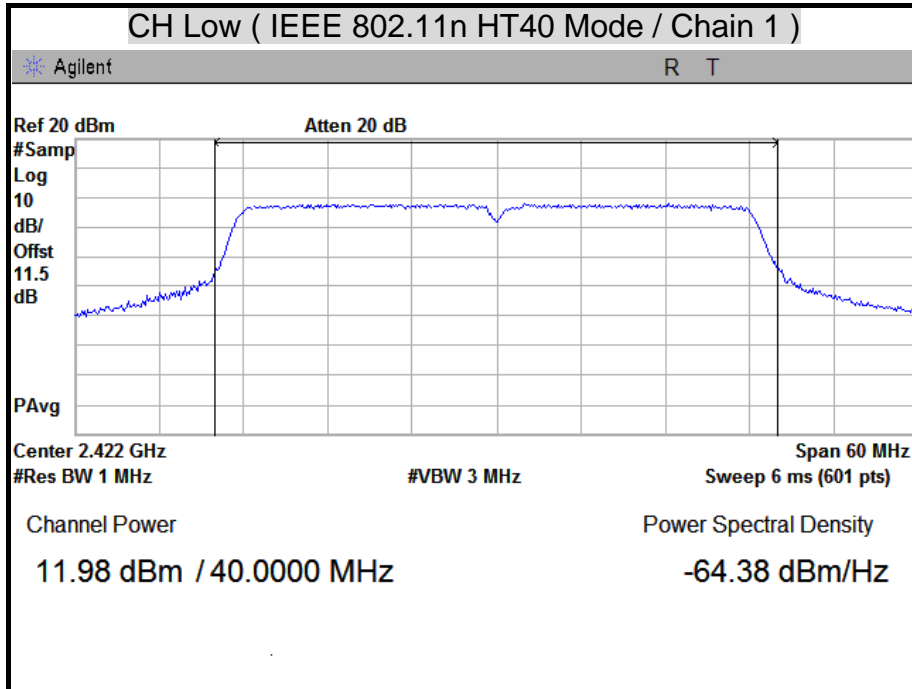

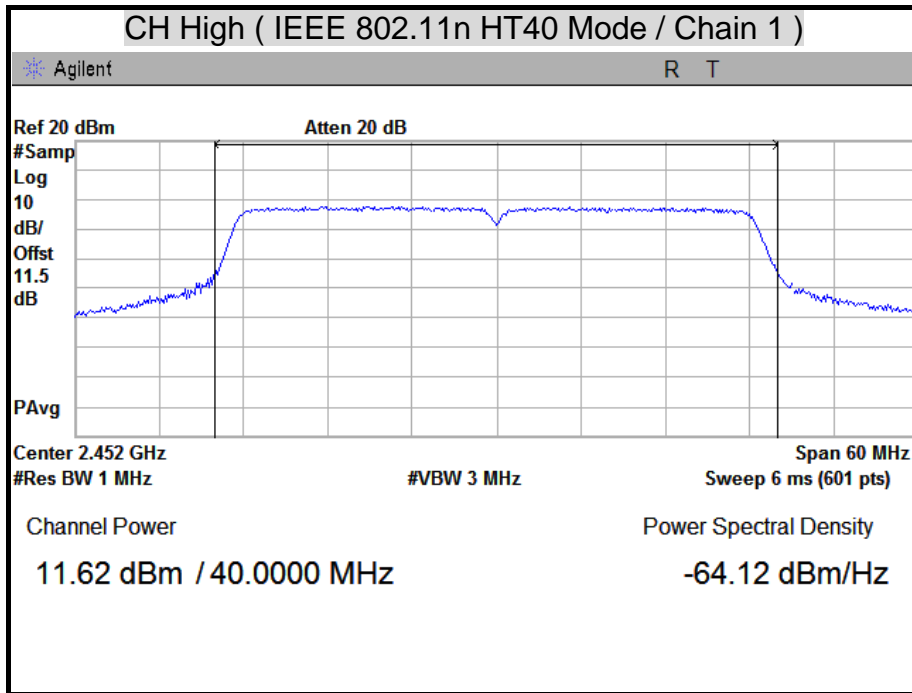



8.4 RADIATED EMISSION

LIMITS

(1) According to § 15.205 (a) Except as shown in paragraph (d) of this section, only spurious emissions are permitted in any of the frequency bands listed below:

MHz	MHz	MHz	GHz
0.090 - 0.110	16.42 - 16.423	399.9 - 410	4.5 - 5.15
¹ 0.495 - 0.505	16.69475 - 16.69525	608 - 614	5.35 - 5.46
2.1735 - 2.1905	16.80425 - 16.80475	960 - 1240	7.25 - 7.75
4.125 - 4.128	25.5 - 25.67	1300 - 1427	8.025 - 8.5
4.17725 - 4.17775	37.5 - 38.25	1435 - 1626.5	9.0 - 9.2
4.20725 - 4.20775	73 - 74.6	1645.5 - 1646.5	9.3 - 9.5
6.215 - 6.218	74.8 - 75.2	1660 - 1710	10.6 - 12.7
6.26775 - 6.26825	108 - 121.94	1718.8 - 1722.2	13.25 - 13.4
6.31175 - 6.31225	123 - 138	2200 - 2300	14.47 - 14.5
8.291 - 8.294	149.9 - 150.05	2310 - 2390	15.35 - 16.2
8.362 - 8.366	156.52475 - 156.52525	2483.5 - 2500	17.7 - 21.4
8.37625 - 8.38675	156.7 - 156.9	2655 - 2900	22.01 - 23.12
8.41425 - 8.41475	162.0125 - 167.17	3260 - 3267	23.6 - 24.0
12.29 - 12.293	167.72 - 173.2	3332 - 3339	31.2 - 31.8
12.51975 - 12.52025	240 - 285	3345.8 - 3338	36.43 - 36.5
12.57675 - 12.57725	322 - 335.4	3600 - 4400	(²)
13.36 - 13.41			

Remark:

- 1. ¹ Until February 1, 1999, this restricted band shall be 0.490-0.510 MHz.
- 2. ² Above 38.6

(2) According to § 15.205 (b) Except as provided in paragraphs (d) and (e), the field strength of emissions appearing within these frequency bands shall not exceed the limits shown in Section 15.209. At frequencies equal to or less than 1000 MHz, compliance with the limits in Section 15.209 shall be demonstrated using measurement instrumentation employing a CISPR quasi-peak detector. Above 1000 MHz, compliance with the emission limits in Section 15.209 shall be demonstrated based on the average value of the measured emissions. The provisions in Section 15.35 apply to these measurements.



(3) According to § 15.209 (a) Except as provided elsewhere in this Subpart, the emissions from an intentional radiator shall not exceed the field strength levels specified in the following table :

Frequency (MHz)	Field Strength (microvolts/meter)	Measurement Distance (meters)
0.009 – 0.490	2400/F(KHz)	300
0.490 – 1.705	24000/F(KHz)	30
1.705 – 30.0	30	30
30 - 88	100 **	3
88 - 216	150 **	3
216 - 960	200 **	3
Above 960	500	3

Remark: **Except as provided in paragraph (g), fundamental emissions from intentional radiators operating under this Section shall not be located in the frequency bands 54-72 MHz, 76-88 MHz, 174-216 MHz or 470-806 MHz. However, operation within these frequency bands is permitted under other sections of this Part, e.g., Sections 15.231 and 15.241.

(4) According to § 15.209 (b) In the emission table above, the tighter limit applies at the band edges.

TEST EQUIPMENT

Radiated Emission / 966Chamber_A

Name of Equipment	Manufacturer	Model	Serial Number	Calibration Due
Spectrum Analyzer	Agilent	E4446A	MY46180323	04/24/2012
EMI Receiver	ROHDE & SCHWARZ	ESCI	100221	04/24/2012
Bi-log Antenna	SCHWARZBECK	VULB 9168	9168-249	10/03/2012
Broad-Band Horn Antenna	SCHWARZBECK	BBHA 9120 D	9120D-778	09/05/2012
Horn Antenna	COM-POWER	AH-840	03077	12/06/2012
Pre-Amplifier	Agilent	8449B	3008A01471	07/24/2012
Pre-Amplifier	HP	8447F	2944A03748	09/18/2012
LOOP Antenna	EMCO	6502	8905-2356	06/10/2012
Band Reject Notch Filter	Micro-Tronics	BRM05702-01	009	N.C.R

Remark: 1. Each piece of equipment is scheduled for calibration once a year.
2. N.C.R = No Calibration Request.



TEST SETUP

The diagram below shows the test setup that is utilized to make the measurements for emission from below 1GHz.

9kHz ~ 30MHz

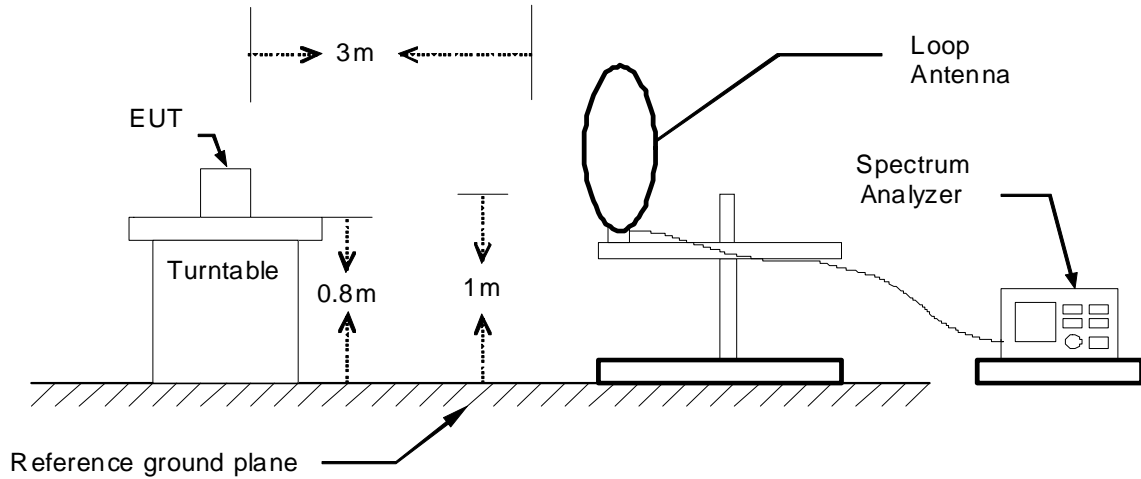

30MHz ~ 1GHz

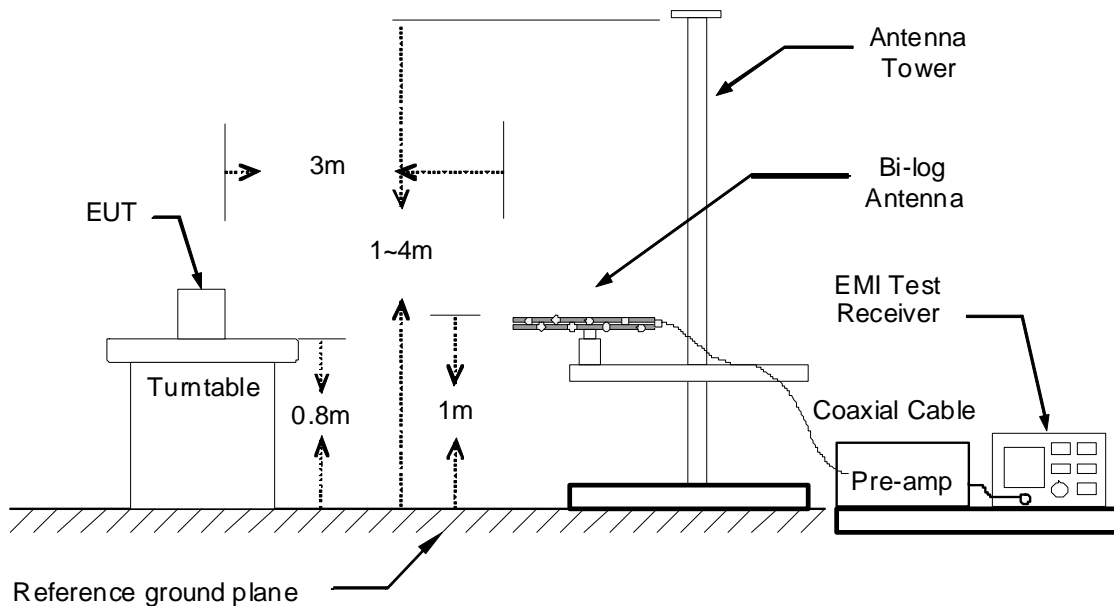



The diagram below shows the test setup that is utilized to make the measurements for emission above 1GHz.

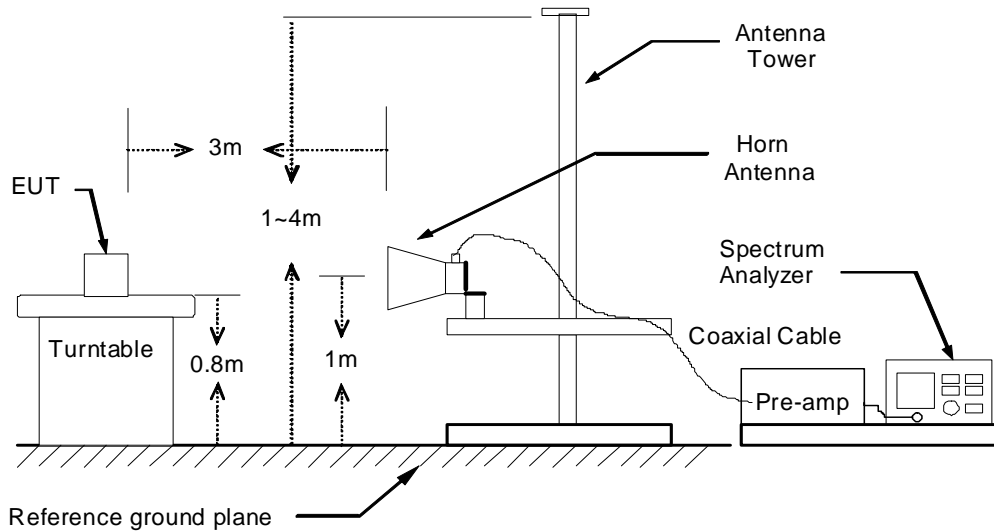

TEST PROCEDURE

1. The EUT was placed on the top of a rotating table 0.8 meters above the ground. The table was rotated 360 degrees to determine the position of the highest radiation.
2. While measuring the radiated emission below 1GHz, the EUT was set 3 meters away from the interference-receiving antenna, which was mounted on the top of a variable-height antenna tower. While measuring the radiated emission above 1GHz, the EUT was set 3 meters away from the interference-receiving antenna.
3. The antenna is a broadband antenna, and its height is varied from one meter to four meters above the ground to determine the maximum value of the field strength. Both horizontal and vertical polarization of the antenna are set to make the measurement.
4. For each suspected emission, the EUT was arranged to its worst case and then the antenna was tuned to heights from 1 meter to 4 meters and the table was turned from 0 degrees to 360 degrees to find the maximum reading.
5. The test-receiver system was set to Peak Detect Function and Specified Bandwidth with Maximum Hold Mode.
6. If the emission level of the EUT in peak mode was 10 dB lower than the limit specified, then testing could be stopped and the peak values of the EUT would be reported. Otherwise the emissions that did not have 10 dB margin would be re-tested one by one using peak, quasi-peak or average method as specified and then reported in a data sheet.

Remark :

1. The resolution bandwidth and video bandwidth of test receiver/spectrum analyzer is 120 KHz for Peak detection (PK) and Quasi-peak detection (QP) at frequency below 1GHz.
2. The resolution bandwidth and video bandwidth of test receiver/spectrum analyzer is 1 MHz for Peak detection and frequency above 1GHz.
3. The resolution bandwidth of test receiver/spectrum analyzer is 1 MHz and the video bandwidth is 10 Hz for Average detection (AV) at frequency above 1GHz.



TEST RESULTS

Below 1 GHz (9kHz ~ 30MHz)

No emission found between lowest internal used/generated frequency to 30MHz.

Below 1 GHz (30MHz ~ 1GHz)

Product Name	802.11bgn WLAN + Bluetooth Mini Card	Test By	Rueyyan Lin
Test Model	BCM943227HMB	Test Date	2012/02/22
Test Mode	IEEE 802.11b TX / CH Middle (worst case)	Temp. & Humidity	24°C, 58%

966 Chamber_A at 3Meter / Horizontal						
Frequency (MHz)	Reading (dBµV)	Correction Factor (dB/m)	Result (dBµV/m)	Limit (dBµV/m)	Margin (dB)	Remark
90.14	40.32	-15.85	24.47	43.50	-19.03	Peak
167.74	41.17	-9.55	31.62	43.50	-11.88	Peak
223.03	43.09	-12.12	30.97	46.00	-15.03	Peak
279.29	43.06	-9.34	33.73	46.00	-12.27	Peak
333.61	39.10	-7.85	31.25	46.00	-14.75	Peak
436.43	31.95	-5.14	26.81	46.00	-19.19	Peak
800.18	33.90	2.00	35.90	46.00	-10.10	Peak

966 Chamber_A at 3Meter / Vertical						
Frequency (MHz)	Reading (dBµV)	Correction Factor (dB/m)	Result (dBµV/m)	Limit (dBµV/m)	Margin (dB)	Remark
34.85	42.01	-10.35	31.66	40.00	-8.34	Peak
166.77	40.21	-9.47	30.75	43.50	-12.75	Peak
278.32	36.61	-9.37	27.24	46.00	-18.76	Peak
436.43	36.30	-5.14	31.16	46.00	-14.84	Peak
597.45	31.42	-1.43	29.98	46.00	-16.02	Peak
653.71	30.93	-0.88	30.05	46.00	-15.95	Peak
800.18	35.49	2.00	37.49	46.00	-8.51	Peak

Remark:

1. Quasi-peak test would be performed if the peak result were greater than the quasi-peak limit.
2. Data of measurement within this frequency range shown " --- " in the table above means the reading of emissions are attenuated more than 20dB below the permissible limits or the field strength is too small to be measured.
3. Correction Factor (dB/m) = Antenna Factor (dB/m) + Cable Loss (dB) – PreAmp.Gain (dB)
4. Result (dBuV/m) = Reading (dBuV) + Correction Factor (dB/m)
5. Margin (dB) = Remark result (dBuV/m) - Quasi-peak limit (dBuV/m).



Product Name	802.11bgn WLAN + Bluetooth Mini Card	Test By	Rueyyan Lin
Test Model	BCM943227HMB	Test Date	2012/02/22
Test Mode	Bluetooth / GFSK TX / CH Middle (worst case)	Temp. & Humidity	24°C, 58%

966 Chamber_A at 3Meter / Horizontal						
Frequency (MHz)	Reading (dBµV)	Correction Factor (dB/m)	Result (dBµV/m)	Limit (dBµV/m)	Margin (dB)	Remark
166.77	43.38	-9.47	33.91	43.50	-9.59	Peak
224.97	43.80	-11.97	31.84	46.00	-14.16	Peak
279.29	43.35	-9.34	34.01	46.00	-11.99	Peak
336.52	39.24	-7.78	31.46	46.00	-14.54	Peak
398.60	34.96	-6.04	28.92	46.00	-17.08	Peak
598.42	29.15	-1.41	27.75	46.00	-18.25	Peak
798.24	35.15	1.97	37.12	46.00	-8.88	Peak

966 Chamber_A at 3Meter / Vertical						
Frequency (MHz)	Reading (dBµV)	Correction Factor (dB/m)	Result (dBµV/m)	Limit (dBµV/m)	Margin (dB)	Remark
37.76	43.55	-10.70	32.85	40.00	-7.15	Peak
166.77	41.22	-9.47	31.76	43.50	-11.74	Peak
278.32	37.75	-9.37	28.38	46.00	-17.62	Peak
334.58	35.13	-7.83	27.30	46.00	-18.70	Peak
443.22	35.48	-4.98	30.50	46.00	-15.50	Peak
653.71	33.12	-0.88	32.24	46.00	-13.76	Peak
798.24	35.77	1.97	37.74	46.00	-8.26	Peak

Remark:

1. Quasi-peak test would be performed if the peak result were greater than the quasi-peak limit.
2. Data of measurement within this frequency range shown " --- " in the table above means the reading of emissions are attenuated more than 20dB below the permissible limits or the field strength is too small to be measured.
3. Correction Factor (dB/m) = Antenna Factor (dB/m) + Cable Loss (dB) – PreAmp.Gain (dB)
4. Result (dBµV/m) = Reading (dBµV) + Correction Factor (dB/m)
5. Margin (dB) = Remark result (dBµV/m) - Quasi-peak limit (dBµV/m).



TX Above 1 GHz

Product Name	802.11bgn WLAN + Bluetooth Mini Card	Test By	Rueyyan Lin
Test Model	BCM943227HMB	Test Date	2012/02/18
Test Mode	IEEE 802.11b TX / CH Low	Temp. & Humidity	21°C, 52%

966 Chamber_A at 3Meter / Horizontal									
Frequency (MHz)	Reading-PK (dBuV)	Reading-AV (dBuV)	Correction Factor (dB/m)	Result-PK (dBuV/m)	Result-AV (dBuV/m)	Limit-PK (dBuV/m)	Limit-AV (dBuV/m)	Margin (dB)	Remark
1478.00	53.92	---	-5.17	48.75	---	74.00	54.00	-5.25	Peak
1764.00	53.67	---	-4.02	49.65	---	74.00	54.00	-4.35	Peak
3330.00	42.49	---	0.97	43.47	---	74.00	54.00	-10.53	Peak
4125.00	41.54	---	3.28	44.81	---	74.00	54.00	-9.19	Peak
4965.00	41.65	---	6.00	47.65	---	74.00	54.00	-6.35	Peak

966 Chamber_A at 3Meter / Vertical									
Frequency (MHz)	Reading-PK (dBuV)	Reading-AV (dBuV)	Correction Factor (dB/m)	Result-PK (dBuV/m)	Result-AV (dBuV/m)	Limit-PK (dBuV/m)	Limit-AV (dBuV/m)	Margin (dB)	Remark
1474.00	54.32	---	-5.19	49.13	---	74.00	54.00	-4.87	Peak
2024.00	54.03	---	-3.00	51.03	---	74.00	54.00	-2.97	Peak
3210.00	43.76	---	0.83	44.59	---	74.00	54.00	-9.41	Peak
3990.00	42.55	---	2.84	45.38	---	74.00	54.00	-8.62	Peak
4725.00	41.99	---	5.22	47.21	---	74.00	54.00	-6.79	Peak

Remark:

1. Measuring frequencies from 1 GHz to the 10th harmonic of highest fundamental frequency.
2. Average test would be performed if the peak result were greater than the average limit.
3. Data of measurement within this frequency range shown " --- " in the table above means the reading of emissions are attenuated more than 20dB below the permissible limits or the field strength is too small to be measured.
4. Measurements above show only up to 6 maximum emissions noted, or would be lesser, with " N/A " remark, if no specific emissions from the EUT are recorded (ie: margin>20dB from the applicable limit) and considered that's already beyond the background noise floor.
5. Result = Reading + Correction Factor
 Margin = Result - Limit
 Remark Peak = Result(PK) - Limit(AV)
 Remark AVG = Result(AV) - Limit(AV)



Product Name	802.11bgn WLAN + Bluetooth Mini Card	Test By	Rueyyan Lin
Test Model	BCM943227HMB	Test Date	2012/02/18
Test Mode	IEEE 802.11b TX / CH Middle	Temp. & Humidity	21°C, 52%

966 Chamber_A at 3Meter / Horizontal

Frequency (MHz)	Reading-PK (dBuV)	Reading-AV (dBuV)	Correction Factor (dB/m)	Result-PK (dBuV/m)	Result-AV (dBuV/m)	Limit-PK (dBuV/m)	Limit-AV (dBuV/m)	Margin (dB)	Remark
1782.00	53.54	---	-3.95	49.60	---	74.00	54.00	-4.40	Peak
2054.00	53.14	---	-2.88	50.26	---	74.00	54.00	-3.74	Peak
3345.00	42.41	---	0.99	43.40	---	74.00	54.00	-10.60	Peak
4470.00	42.30	---	4.40	46.70	---	74.00	54.00	-7.30	Peak
6390.00	41.36	---	9.37	50.73	---	74.00	54.00	-3.27	Peak

966 Chamber_A at 3Meter / Vertical

Frequency (MHz)	Reading-PK (dBuV)	Reading-AV (dBuV)	Correction Factor (dB/m)	Result-PK (dBuV/m)	Result-AV (dBuV/m)	Limit-PK (dBuV/m)	Limit-AV (dBuV/m)	Margin (dB)	Remark
1474.00	53.98	---	-5.19	48.78	---	74.00	54.00	-5.22	Peak
1910.00	52.93	---	-3.45	49.48	---	74.00	54.00	-4.52	Peak
3270.00	43.30	---	0.90	44.20	---	74.00	54.00	-9.80	Peak
3990.00	43.57	---	2.84	46.41	---	74.00	54.00	-7.59	Peak
5235.00	41.34	---	6.50	47.85	---	74.00	54.00	-6.15	Peak

Remark:

1. Measuring frequencies from 1 GHz to the 10th harmonic of highest fundamental frequency.
2. Average test would be performed if the peak result were greater than the average limit.
3. Data of measurement within this frequency range shown " --- " in the table above means the reading of emissions are attenuated more than 20dB below the permissible limits or the field strength is too small to be measured.
4. Measurements above show only up to 6 maximum emissions noted, or would be lesser, with " N/A " remark, if no specific emissions from the EUT are recorded (ie: margin>20dB from the applicable limit) and considered that's already beyond the background noise floor.
5. Result = Reading + Correction Factor
Margin = Result - Limit
Remark Peak = Result(PK) - Limit(AV)
Remark AVG = Result(AV) - Limit(AV)



Product Name	802.11bgn WLAN + Bluetooth Mini Card	Test By	Rueyyan Lin
Test Model	BCM943227HMB	Test Date	2012/02/18
Test Mode	IEEE 802.11b TX / CH High	Temp. & Humidity	21°C, 52%

966 Chamber_A at 3Meter / Horizontal

Frequency (MHz)	Reading-PK (dBuV)	Reading-AV (dBuV)	Correction Factor (dB/m)	Result-PK (dBuV/m)	Result-AV (dBuV/m)	Limit-PK (dBuV/m)	Limit-AV (dBuV/m)	Margin (dB)	Remark
1388.00	54.57	---	-5.70	48.88	---	74.00	54.00	-5.12	Peak
1880.00	53.44	---	-3.57	49.88	---	74.00	54.00	-4.12	Peak
3165.00	43.55	---	0.77	44.32	---	74.00	54.00	-9.68	Peak
4710.00	41.64	---	5.18	46.82	---	74.00	54.00	-7.18	Peak
6435.00	41.97	---	9.53	51.50	---	74.00	54.00	-2.50	Peak

966 Chamber_A at 3Meter / Vertical

Frequency (MHz)	Reading-PK (dBuV)	Reading-AV (dBuV)	Correction Factor (dB/m)	Result-PK (dBuV/m)	Result-AV (dBuV/m)	Limit-PK (dBuV/m)	Limit-AV (dBuV/m)	Margin (dB)	Remark
1528.00	54.43	---	-4.93	49.50	---	74.00	54.00	-4.50	Peak
1880.00	52.72	---	-3.57	49.15	---	74.00	54.00	-4.85	Peak
3990.00	42.17	---	2.84	45.00	---	74.00	54.00	-9.00	Peak
4815.00	41.33	---	5.51	46.84	---	74.00	54.00	-7.16	Peak
6285.00	41.14	---	8.98	50.13	---	74.00	54.00	-3.87	Peak

Remark:

1. Measuring frequencies from 1 GHz to the 10th harmonic of highest fundamental frequency.
2. Average test would be performed if the peak result were greater than the average limit.
3. Data of measurement within this frequency range shown " --- " in the table above means the reading of emissions are attenuated more than 20dB below the permissible limits or the field strength is too small to be measured.
4. Measurements above show only up to 6 maximum emissions noted, or would be lesser, with " N/A " remark, if no specific emissions from the EUT are recorded (ie: margin>20dB from the applicable limit) and considered that's already beyond the background noise floor.
5. Result = Reading + Correction Factor
Margin = Result - Limit
Remark Peak = Result(PK) - Limit(AV)
Remark AVG = Result(AV) - Limit(AV)



Product Name	802.11bgn WLAN + Bluetooth Mini Card	Test By	Rueyyan Lin
Test Model	BCM943227HMB	Test Date	2012/02/18
Test Mode	IEEE 802.11g TX / CH Low	Temp. & Humidity	21°C, 52%

966 Chamber_A at 3Meter / Horizontal									
Frequency (MHz)	Reading-PK (dBuV)	Reading-AV (dBuV)	Correction Factor (dB/m)	Result-PK (dBuV/m)	Result-AV (dBuV/m)	Limit-PK (dBuV/m)	Limit-AV (dBuV/m)	Margin (dB)	Remark
1512.00	53.83	---	-4.99	48.84	---	74.00	54.00	-5.16	Peak
1728.00	53.83	---	-4.16	49.67	---	74.00	54.00	-4.33	Peak
3450.00	43.30	---	1.12	44.42	---	74.00	54.00	-9.58	Peak
4725.00	42.26	---	5.22	47.48	---	74.00	54.00	-6.52	Peak
6135.00	41.67	---	8.43	50.10	---	74.00	54.00	-3.90	Peak

966 Chamber_A at 3Meter / Vertical									
Frequency (MHz)	Reading-PK (dBuV)	Reading-AV (dBuV)	Correction Factor (dB/m)	Result-PK (dBuV/m)	Result-AV (dBuV/m)	Limit-PK (dBuV/m)	Limit-AV (dBuV/m)	Margin (dB)	Remark
1628.00	53.68	---	-4.54	49.14	---	74.00	54.00	-4.86	Peak
2148.00	54.68	---	-2.51	52.17	---	74.00	54.00	-1.83	Peak
3990.00	42.52	---	2.84	45.35	---	74.00	54.00	-8.65	Peak
4800.00	41.53	---	5.47	47.00	---	74.00	54.00	-7.00	Peak
6210.00	41.74	---	8.71	50.45	---	74.00	54.00	-3.55	Peak

Remark:

1. Measuring frequencies from 1 GHz to the 10th harmonic of highest fundamental frequency.
2. Average test would be performed if the peak result were greater than the average limit.
3. Data of measurement within this frequency range shown " --- " in the table above means the reading of emissions are attenuated more than 20dB below the permissible limits or the field strength is too small to be measured.
4. Measurements above show only up to 6 maximum emissions noted, or would be lesser, with " N/A " remark, if no specific emissions from the EUT are recorded (ie: margin>20dB from the applicable limit) and considered that's already beyond the background noise floor.
5. Result = Reading + Correction Factor
Margin = Result - Limit
Remark Peak = Result(PK) - Limit(AV)
Remark AVG = Result(AV) - Limit(AV)



Product Name	802.11bgn WLAN + Bluetooth Mini Card	Test By	Rueyyan Lin
Test Model	BCM943227HMB	Test Date	2012/02/18
Test Mode	IEEE 802.11g TX / CH Middle	Temp. & Humidity	21°C, 52%

966 Chamber_A at 3Meter / Horizontal									
Frequency (MHz)	Reading-PK (dBuV)	Reading-AV (dBuV)	Correction Factor (dB/m)	Result-PK (dBuV/m)	Result-AV (dBuV/m)	Limit-PK (dBuV/m)	Limit-AV (dBuV/m)	Margin (dB)	Remark
1512.00	53.96	---	-4.99	48.96	---	74.00	54.00	-5.04	Peak
1998.00	53.35	---	-3.11	50.24	---	74.00	54.00	-3.76	Peak
3285.00	42.88	---	0.92	43.80	---	74.00	54.00	-10.20	Peak
4335.00	41.72	---	3.96	45.68	---	74.00	54.00	-8.32	Peak
5550.00	41.34	---	7.05	48.39	---	74.00	54.00	-5.61	Peak

966 Chamber_A at 3Meter / Vertical									
Frequency (MHz)	Reading-PK (dBuV)	Reading-AV (dBuV)	Correction Factor (dB/m)	Result-PK (dBuV/m)	Result-AV (dBuV/m)	Limit-PK (dBuV/m)	Limit-AV (dBuV/m)	Margin (dB)	Remark
1518.00	53.02	---	-4.97	48.05	---	74.00	54.00	-5.95	Peak
1994.00	53.50	---	-3.12	50.37	---	74.00	54.00	-3.63	Peak
3195.00	42.92	---	0.81	43.73	---	74.00	54.00	-10.27	Peak
3990.00	42.22	---	2.84	45.05	---	74.00	54.00	-8.95	Peak
4905.00	41.67	---	5.80	47.47	---	74.00	54.00	-6.53	Peak

Remark:

1. Measuring frequencies from 1 GHz to the 10th harmonic of highest fundamental frequency.
2. Average test would be performed if the peak result were greater than the average limit.
3. Data of measurement within this frequency range shown " --- " in the table above means the reading of emissions are attenuated more than 20dB below the permissible limits or the field strength is too small to be measured.
4. Measurements above show only up to 6 maximum emissions noted, or would be lesser, with " N/A " remark, if no specific emissions from the EUT are recorded (ie: margin>20dB from the applicable limit) and considered that's already beyond the background noise floor.
5. Result = Reading + Correction Factor
Margin = Result - Limit
Remark Peak = Result(PK) - Limit(AV)
Remark AVG = Result(AV) - Limit(AV)



Product Name	802.11bgn WLAN + Bluetooth Mini Card	Test By	Rueyyan Lin
Test Model	BCM943227HMB	Test Date	2012/02/18
Test Mode	IEEE 802.11g TX / CH High	Temp. & Humidity	21°C, 52%

966 Chamber_A at 3Meter / Horizontal

Frequency (MHz)	Reading-PK (dBuV)	Reading-AV (dBuV)	Correction Factor (dB/m)	Result-PK (dBuV/m)	Result-AV (dBuV/m)	Limit-PK (dBuV/m)	Limit-AV (dBuV/m)	Margin (dB)	Remark
1472.00	53.90	---	-5.20	48.69	---	74.00	54.00	-5.31	Peak
1784.00	54.05	---	-3.94	50.11	---	74.00	54.00	-3.89	Peak
3120.00	42.24	---	0.72	42.96	---	74.00	54.00	-11.04	Peak
3705.00	42.88	---	1.87	44.75	---	74.00	54.00	-9.25	Peak
5070.00	41.48	---	6.23	47.71	---	74.00	54.00	-6.29	Peak

966 Chamber_A at 3Meter / Vertical

Frequency (MHz)	Reading-PK (dBuV)	Reading-AV (dBuV)	Correction Factor (dB/m)	Result-PK (dBuV/m)	Result-AV (dBuV/m)	Limit-PK (dBuV/m)	Limit-AV (dBuV/m)	Margin (dB)	Remark
1622.00	54.53	---	-4.57	49.97	---	74.00	54.00	-4.03	Peak
2132.00	53.85	---	-2.57	51.28	---	74.00	54.00	-2.72	Peak
3195.00	42.37	---	0.81	43.18	---	74.00	54.00	-10.82	Peak
3990.00	43.85	---	2.84	46.69	---	74.00	54.00	-7.31	Peak
5805.00	41.44	---	7.55	48.99	---	74.00	54.00	-5.01	Peak

Remark:

1. Measuring frequencies from 1 GHz to the 10th harmonic of highest fundamental frequency.
2. Average test would be performed if the peak result were greater than the average limit.
3. Data of measurement within this frequency range shown " --- " in the table above means the reading of emissions are attenuated more than 20dB below the permissible limits or the field strength is too small to be measured.
4. Measurements above show only up to 6 maximum emissions noted, or would be lesser, with " N/A " remark, if no specific emissions from the EUT are recorded (ie: margin>20dB from the applicable limit) and considered that's already beyond the background noise floor.
5. Result = Reading + Correction Factor
Margin = Result - Limit
Remark Peak = Result(PK) - Limit(AV)
Remark AVG = Result(AV) - Limit(AV)



Product Name	802.11bgn WLAN + Bluetooth Mini Card	Test By	Rueyyan Lin
Test Model	BCM943227HMB	Test Date	2012/02/18
Test Mode	IEEE 802.11n HT20 TX / CH Low	Temp. & Humidity	21°C, 52%

966 Chamber_A at 3Meter / Horizontal									
Frequency (MHz)	Reading-PK (dBuV)	Reading-AV (dBuV)	Correction Factor (dB/m)	Result-PK (dBuV/m)	Result-AV (dBuV/m)	Limit-PK (dBuV/m)	Limit-AV (dBuV/m)	Margin (dB)	Remark
1440.00	54.15	---	-5.39	48.76	---	74.00	54.00	-5.24	Peak
1796.00	53.05	---	-3.89	49.16	---	74.00	54.00	-4.84	Peak
3240.00	42.75	---	0.86	43.61	---	74.00	54.00	-10.39	Peak
4695.00	41.63	---	5.13	46.76	---	74.00	54.00	-7.24	Peak
5985.00	41.62	---	7.91	49.53	---	74.00	54.00	-4.47	Peak
966 Chamber_A at 3Meter / Vertical									
Frequency (MHz)	Reading-PK (dBuV)	Reading-AV (dBuV)	Correction Factor (dB/m)	Result-PK (dBuV/m)	Result-AV (dBuV/m)	Limit-PK (dBuV/m)	Limit-AV (dBuV/m)	Margin (dB)	Remark
1374.00	53.52	---	-5.78	47.74	---	74.00	54.00	-6.26	Peak
1746.00	53.34	---	-4.09	49.25	---	74.00	54.00	-4.75	Peak
3285.00	42.98	---	0.92	43.90	---	74.00	54.00	-10.10	Peak
3990.00	43.30	---	2.84	46.14	---	74.00	54.00	-7.86	Peak
6105.00	41.82	---	8.32	50.15	---	74.00	54.00	-3.85	Peak

Remark:

1. Measuring frequencies from 1 GHz to the 10th harmonic of highest fundamental frequency.
2. Average test would be performed if the peak result were greater than the average limit.
3. Data of measurement within this frequency range shown " --- " in the table above means the reading of emissions are attenuated more than 20dB below the permissible limits or the field strength is too small to be measured.
4. Measurements above show only up to 6 maximum emissions noted, or would be lesser, with " N/A " remark, if no specific emissions from the EUT are recorded (ie: margin>20dB from the applicable limit) and considered that's already beyond the background noise floor.
5. Result = Reading + Correction Factor
 Margin = Result - Limit
 Remark Peak = Result(PK) - Limit(AV)
 Remark AVG = Result(AV) - Limit(AV)



Product Name	802.11bgn WLAN + Bluetooth Mini Card	Test By	Rueyyan Lin
Test Model	BCM943227HMB	Test Date	2012/02/18
Test Mode	IEEE 802.11n HT20 TX / CH Middle	Temp. & Humidity	21°C, 52%

966 Chamber_A at 3Meter / Horizontal

Frequency (MHz)	Reading-PK (dBuV)	Reading-AV (dBuV)	Correction Factor (dB/m)	Result-PK (dBuV/m)	Result-AV (dBuV/m)	Limit-PK (dBuV/m)	Limit-AV (dBuV/m)	Margin (dB)	Remark
1378.00	53.61	---	-5.76	47.85	---	74.00	54.00	-6.15	Peak
1812.00	52.26	---	-3.83	48.43	---	74.00	54.00	-5.57	Peak
3720.00	41.74	---	1.92	43.67	---	74.00	54.00	-10.33	Peak
4785.00	42.29	---	5.42	47.71	---	74.00	54.00	-6.29	Peak
6150.00	41.09	---	8.49	49.58	---	74.00	54.00	-4.42	Peak

966 Chamber_A at 3Meter / Vertical

Frequency (MHz)	Reading-PK (dBuV)	Reading-AV (dBuV)	Correction Factor (dB/m)	Result-PK (dBuV/m)	Result-AV (dBuV/m)	Limit-PK (dBuV/m)	Limit-AV (dBuV/m)	Margin (dB)	Remark
1364.00	53.93	---	-5.84	48.09	---	74.00	54.00	-5.91	Peak
1754.00	53.88	---	-4.05	49.83	---	74.00	54.00	-4.17	Peak
3165.00	42.79	---	0.77	43.56	---	74.00	54.00	-10.44	Peak
3990.00	43.81	---	2.84	46.64	---	74.00	54.00	-7.36	Peak
5610.00	41.68	---	7.17	48.84	---	74.00	54.00	-5.16	Peak

Remark:

1. Measuring frequencies from 1 GHz to the 10th harmonic of highest fundamental frequency.
2. Average test would be performed if the peak result were greater than the average limit.
3. Data of measurement within this frequency range shown " --- " in the table above means the reading of emissions are attenuated more than 20dB below the permissible limits or the field strength is too small to be measured.
4. Measurements above show only up to 6 maximum emissions noted, or would be lesser, with " N/A " remark, if no specific emissions from the EUT are recorded (ie: margin>20dB from the applicable limit) and considered that's already beyond the background noise floor.
5. Result = Reading + Correction Factor
Margin = Result - Limit
Remark Peak = Result(PK) - Limit(AV)
Remark AVG = Result(AV) - Limit(AV)



Product Name	802.11bgn WLAN + Bluetooth Mini Card	Test By	Rueyyan Lin
Test Model	BCM943227HMB	Test Date	2012/02/18
Test Mode	IEEE 802.11n HT20 TX / CH High	Temp. & Humidity	21°C, 52%

966 Chamber_A at 3Meter / Horizontal

Frequency (MHz)	Reading-PK (dBuV)	Reading-AV (dBuV)	Correction Factor (dB/m)	Result-PK (dBuV/m)	Result-AV (dBuV/m)	Limit-PK (dBuV/m)	Limit-AV (dBuV/m)	Margin (dB)	Remark
1596.00	53.18	---	-4.67	48.52	---	74.00	54.00	-5.48	Peak
2394.00	53.01	---	-1.52	51.49	---	74.00	54.00	-2.51	Peak
3210.00	43.21	---	0.83	44.04	---	74.00	54.00	-9.96	Peak
4620.00	41.73	---	4.89	46.61	---	74.00	54.00	-7.39	Peak
6645.00	41.58	---	10.26	51.83	---	74.00	54.00	-2.17	Peak

966 Chamber_A at 3Meter / Vertical

Frequency (MHz)	Reading-PK (dBuV)	Reading-AV (dBuV)	Correction Factor (dB/m)	Result-PK (dBuV/m)	Result-AV (dBuV/m)	Limit-PK (dBuV/m)	Limit-AV (dBuV/m)	Margin (dB)	Remark
1452.00	53.69	---	-5.32	48.37	---	74.00	54.00	-5.63	Peak
1990.00	53.54	---	-3.14	50.40	---	74.00	54.00	-3.60	Peak
3990.00	42.46	---	2.84	45.29	---	74.00	54.00	-8.71	Peak
4770.00	41.42	---	5.37	46.79	---	74.00	54.00	-7.21	Peak
5610.00	42.43	---	7.17	49.60	---	74.00	54.00	-4.40	Peak

Remark:

1. Measuring frequencies from 1 GHz to the 10th harmonic of highest fundamental frequency.
2. Average test would be performed if the peak result were greater than the average limit.
3. Data of measurement within this frequency range shown " --- " in the table above means the reading of emissions are attenuated more than 20dB below the permissible limits or the field strength is too small to be measured.
4. Measurements above show only up to 6 maximum emissions noted, or would be lesser, with " N/A " remark, if no specific emissions from the EUT are recorded (ie: margin>20dB from the applicable limit) and considered that's already beyond the background noise floor.
5. $Result = Reading + Correction\ Factor$
 $Margin = Result - Limit$
 $Remark\ Peak = Result(PK) - Limit(AV)$
 $Remark\ AVG = Result(AV) - Limit(AV)$



Product Name	802.11bgn WLAN + Bluetooth Mini Card	Test By	Rueyyan Lin
Test Model	BCM943227HMB	Test Date	2012/02/18
Test Mode	IEEE 802.11n HT40 TX / CH Low	Temp. & Humidity	21°C, 52%

966 Chamber_A at 3Meter / Horizontal

Frequency (MHz)	Reading-PK (dBuV)	Reading-AV (dBuV)	Correction Factor (dB/m)	Result-PK (dBuV/m)	Result-AV (dBuV/m)	Limit-PK (dBuV/m)	Limit-AV (dBuV/m)	Margin (dB)	Remark
1490.00	53.51	---	-5.10	48.41	---	74.00	54.00	-5.59	Peak
1990.00	52.34	---	-3.14	49.20	---	74.00	54.00	-4.80	Peak
3375.00	42.76	---	1.03	43.79	---	74.00	54.00	-10.21	Peak
4695.00	41.67	---	5.13	46.80	---	74.00	54.00	-7.20	Peak
6780.00	41.34	---	10.71	52.05	---	74.00	54.00	-1.95	Peak

966 Chamber_A at 3Meter / Vertical

Frequency (MHz)	Reading-PK (dBuV)	Reading-AV (dBuV)	Correction Factor (dB/m)	Result-PK (dBuV/m)	Result-AV (dBuV/m)	Limit-PK (dBuV/m)	Limit-AV (dBuV/m)	Margin (dB)	Remark
1592.00	54.16	---	-4.68	49.48	---	74.00	54.00	-4.52	Peak
2056.00	52.71	---	-2.87	49.83	---	74.00	54.00	-4.17	Peak
3990.00	44.84	---	2.84	47.68	---	74.00	54.00	-6.32	Peak
4770.00	41.74	---	5.37	47.11	---	74.00	54.00	-6.89	Peak
6225.00	40.98	---	8.76	49.75	---	74.00	54.00	-4.25	Peak

Remark:

1. Measuring frequencies from 1 GHz to the 10th harmonic of highest fundamental frequency.
2. Average test would be performed if the peak result were greater than the average limit.
3. Data of measurement within this frequency range shown " --- " in the table above means the reading of emissions are attenuated more than 20dB below the permissible limits or the field strength is too small to be measured.
4. Measurements above show only up to 6 maximum emissions noted, or would be lesser, with " N/A " remark, if no specific emissions from the EUT are recorded (ie: margin>20dB from the applicable limit) and considered that's already beyond the background noise floor.
5. Result = Reading + Correction Factor
Margin = Result - Limit
Remark Peak = Result(PK) - Limit(AV)
Remark AVG = Result(AV) - Limit(AV)



Product Name	802.11bgn WLAN + Bluetooth Mini Card	Test By	Rueyyan Lin
Test Model	BCM943227HMB	Test Date	2012/02/18
Test Mode	IEEE 802.11n HT40 TX / CH Middle	Temp. & Humidity	21°C, 52%

966 Chamber_A at 3Meter / Horizontal									
Frequency (MHz)	Reading-PK (dBuV)	Reading-AV (dBuV)	Correction Factor (dB/m)	Result-PK (dBuV/m)	Result-AV (dBuV/m)	Limit-PK (dBuV/m)	Limit-AV (dBuV/m)	Margin (dB)	Remark
1528.00	53.74	---	-4.93	48.81	---	74.00	54.00	-5.19	Peak
1778.00	53.59	---	-3.96	49.63	---	74.00	54.00	-4.37	Peak
3480.00	43.16	---	1.16	44.32	---	74.00	54.00	-9.68	Peak
5025.00	42.10	---	6.15	48.25	---	74.00	54.00	-5.75	Peak
6195.00	41.26	---	8.65	49.92	---	74.00	54.00	-4.08	Peak

966 Chamber_A at 3Meter / Vertical									
Frequency (MHz)	Reading-PK (dBuV)	Reading-AV (dBuV)	Correction Factor (dB/m)	Result-PK (dBuV/m)	Result-AV (dBuV/m)	Limit-PK (dBuV/m)	Limit-AV (dBuV/m)	Margin (dB)	Remark
1686.00	52.93	---	-4.32	48.61	---	74.00	54.00	-5.39	Peak
1970.00	53.59	---	-3.22	50.37	---	74.00	54.00	-3.63	Peak
3375.00	43.12	---	1.03	44.15	---	74.00	54.00	-9.85	Peak
3990.00	42.97	---	2.84	45.80	---	74.00	54.00	-8.20	Peak
5640.00	41.53	---	7.23	48.75	---	74.00	54.00	-5.25	Peak

Remark:

1. Measuring frequencies from 1 GHz to the 10th harmonic of highest fundamental frequency.
2. Average test would be performed if the peak result were greater than the average limit.
3. Data of measurement within this frequency range shown " --- " in the table above means the reading of emissions are attenuated more than 20dB below the permissible limits or the field strength is too small to be measured.
4. Measurements above show only up to 6 maximum emissions noted, or would be lesser, with " N/A " remark, if no specific emissions from the EUT are recorded (ie: margin>20dB from the applicable limit) and considered that's already beyond the background noise floor.
5. Result = Reading + Correction Factor
Margin = Result - Limit
Remark Peak = Result(PK) - Limit(AV)
Remark AVG = Result(AV) - Limit(AV)



Product Name	802.11bgn WLAN + Bluetooth Mini Card	Test By	Rueyyan Lin
Test Model	BCM943227HMB	Test Date	2012/02/18
Test Mode	IEEE 802.11n HT40 TX / CH High	Temp. & Humidity	21°C, 52%

966 Chamber_A at 3Meter / Horizontal

Frequency (MHz)	Reading-PK (dBuV)	Reading-AV (dBuV)	Correction Factor (dB/m)	Result-PK (dBuV/m)	Result-AV (dBuV/m)	Limit-PK (dBuV/m)	Limit-AV (dBuV/m)	Margin (dB)	Remark
1510.00	53.50	---	-5.00	48.50	---	74.00	54.00	-5.50	Peak
2238.00	52.70	---	-2.14	50.56	---	74.00	54.00	-3.44	Peak
3090.00	42.07	---	0.68	42.75	---	74.00	54.00	-11.25	Peak
3615.00	42.80	---	1.57	44.37	---	74.00	54.00	-9.63	Peak
4860.00	42.03	---	5.66	47.69	---	74.00	54.00	-6.31	Peak

966 Chamber_A at 3Meter / Vertical

Frequency (MHz)	Reading-PK (dBuV)	Reading-AV (dBuV)	Correction Factor (dB/m)	Result-PK (dBuV/m)	Result-AV (dBuV/m)	Limit-PK (dBuV/m)	Limit-AV (dBuV/m)	Margin (dB)	Remark
1384.00	54.31	---	-5.72	48.59	---	74.00	54.00	-5.41	Peak
1776.00	53.19	---	-3.97	49.22	---	74.00	54.00	-4.78	Peak
3240.00	42.46	---	0.86	43.33	---	74.00	54.00	-10.67	Peak
3990.00	42.64	---	2.84	45.48	---	74.00	54.00	-8.52	Peak
5220.00	41.16	---	6.48	47.64	---	74.00	54.00	-6.36	Peak

Remark:

1. Measuring frequencies from 1 GHz to the 10th harmonic of highest fundamental frequency.
2. Average test would be performed if the peak result were greater than the average limit.
3. Data of measurement within this frequency range shown " --- " in the table above means the reading of emissions are attenuated more than 20dB below the permissible limits or the field strength is too small to be measured.
4. Measurements above show only up to 6 maximum emissions noted, or would be lesser, with " N/A " remark, if no specific emissions from the EUT are recorded (ie: margin>20dB from the applicable limit) and considered that's already beyond the background noise floor.
5. Result = Reading + Correction Factor
Margin = Result - Limit
Remark Peak = Result(PK) - Limit(AV)
Remark AVG = Result(AV) - Limit(AV)



Product Name	802.11bgn WLAN + Bluetooth Mini Card	Test By	Rueyyan Lin
Test Model	BCM943227HMB	Test Date	2012/02/22
Test Mode	Bluetooth / GFSK TX / CH Low	Temp. & Humidity	24°C, 58%

966 Chamber_A at 3Meter / Horizontal									
Frequency (MHz)	Reading-PK (dBuV)	Reading-AV (dBuV)	Correction Factor (dB/m)	Result-PK (dBuV/m)	Result-AV (dBuV/m)	Limit-PK (dBuV/m)	Limit-AV (dBuV/m)	Margin (dB)	Remark
1198.00	48.73	---	-6.82	41.91	---	74.00	54.00	-12.09	Peak
1696.00	44.31	---	-4.28	40.03	---	74.00	54.00	-13.97	Peak
1864.00	44.13	---	-3.63	40.51	---	74.00	54.00	-13.49	Peak
2502.00	46.73	---	-1.08	45.65	---	74.00	54.00	-8.35	Peak
2670.00	44.23	---	-0.53	43.70	---	74.00	54.00	-10.30	Peak
3210.00	42.74	---	0.83	43.57	---	74.00	54.00	-10.43	Peak
5115.00	41.34	---	6.30	47.64	---	74.00	54.00	-6.36	Peak
6375.00	41.74	---	9.31	51.05	---	74.00	54.00	-2.95	Peak

966 Chamber_A at 3Meter / Vertical									
Frequency (MHz)	Reading-PK (dBuV)	Reading-AV (dBuV)	Correction Factor (dB/m)	Result-PK (dBuV/m)	Result-AV (dBuV/m)	Limit-PK (dBuV/m)	Limit-AV (dBuV/m)	Margin (dB)	Remark
1196.00	50.06	---	-6.83	43.24	---	74.00	54.00	-10.76	Peak
1338.00	46.26	---	-5.99	40.27	---	74.00	54.00	-13.73	Peak
1604.00	49.28	---	-4.64	44.65	---	74.00	54.00	-9.35	Peak
2282.00	44.78	---	-1.97	42.82	---	74.00	54.00	-11.18	Peak
2522.00	46.36	---	-1.02	45.34	---	74.00	54.00	-8.66	Peak
3120.00	43.76	---	0.72	44.47	---	74.00	54.00	-9.53	Peak
4485.00	41.14	---	4.45	45.59	---	74.00	54.00	-8.41	Peak
6150.00	40.80	---	8.49	49.29	---	74.00	54.00	-4.71	Peak

Remark:

1. Measuring frequencies from 1 GHz to the 10th harmonic of highest fundamental frequency.
2. Average test would be performed if the peak result were greater than the average limit.
3. Data of measurement within this frequency range shown " --- " in the table above means the reading of emissions are attenuated more than 20dB below the permissible limits or the field strength is too small to be measured.
4. Measurements above show only up to 6 maximum emissions noted, or would be lesser, with " N/A " remark, if no specific emissions from the EUT are recorded (ie: margin>20dB from the applicable limit) and considered that's already beyond the background noise floor.
5. Result = Reading + Correction Factor
Margin = Result - Limit
Remark Peak = Result(PK) - Limit(AV)
Remark AVG = Result(AV) - Limit(AV)



Product Name	802.11bgn WLAN + Bluetooth Mini Card	Test By	Rueyyan Lin
Test Model	BCM943227HMB	Test Date	2012/02/22
Test Mode	Bluetooth / GFSK TX / CH Middle	Temp. & Humidity	24°C, 58%

966 Chamber_A at 3Meter / Horizontal									
Frequency (MHz)	Reading-PK (dBuV)	Reading-AV (dBuV)	Correction Factor (dB/m)	Result-PK (dBuV/m)	Result-AV (dBuV/m)	Limit-PK (dBuV/m)	Limit-AV (dBuV/m)	Margin (dB)	Remark
1196.00	49.38	---	-6.83	42.56	---	74.00	54.00	-11.44	Peak
1696.00	44.75	---	-4.28	40.47	---	74.00	54.00	-13.53	Peak
2502.00	47.22	---	-1.08	46.13	---	74.00	54.00	-7.87	Peak
2742.00	43.56	---	-0.29	43.27	---	74.00	54.00	-10.73	Peak
3165.00	43.41	---	0.77	44.18	---	74.00	54.00	-9.82	Peak
4980.00	41.58	---	6.05	47.62	---	74.00	54.00	-6.38	Peak
6405.00	40.94	---	9.42	50.36	---	74.00	54.00	-3.64	Peak

966 Chamber_A at 3Meter / Vertical									
Frequency (MHz)	Reading-PK (dBuV)	Reading-AV (dBuV)	Correction Factor (dB/m)	Result-PK (dBuV/m)	Result-AV (dBuV/m)	Limit-PK (dBuV/m)	Limit-AV (dBuV/m)	Margin (dB)	Remark
1198.00	50.31	---	-6.82	43.50	---	74.00	54.00	-10.50	Peak
1600.00	49.49	---	-4.65	44.84	---	74.00	54.00	-9.16	Peak
2320.00	45.38	---	-1.81	43.57	---	74.00	54.00	-10.43	Peak
2506.00	46.87	---	-1.07	45.80	---	74.00	54.00	-8.20	Peak
2668.00	43.50	---	-0.53	42.96	---	74.00	54.00	-11.04	Peak
3300.00	43.61	---	0.94	44.55	---	74.00	54.00	-9.45	Peak
4965.00	41.11	---	6.00	47.11	---	74.00	54.00	-6.89	Peak
6495.00	41.14	---	9.75	50.90	---	74.00	54.00	-3.10	Peak

Remark:

1. Measuring frequencies from 1 GHz to the 10th harmonic of highest fundamental frequency.
2. Average test would be performed if the peak result were greater than the average limit.
3. Data of measurement within this frequency range shown " --- " in the table above means the reading of emissions are attenuated more than 20dB below the permissible limits or the field strength is too small to be measured.
4. Measurements above show only up to 6 maximum emissions noted, or would be lesser, with " N/A " remark, if no specific emissions from the EUT are recorded (ie: margin>20dB from the applicable limit) and considered that's already beyond the background noise floor.
5. Result = Reading + Correction Factor
Margin = Result - Limit
Remark Peak = Result(PK) - Limit(AV)
Remark AVG = Result(AV) - Limit(AV)



Product Name	802.11bgn WLAN + Bluetooth Mini Card	Test By	Rueyyan Lin
Test Model	BCM943227HMB	Test Date	2012/02/22
Test Mode	Bluetooth / GFSK TX / CH High	Temp. & Humidity	24°C, 58%

966 Chamber_A at 3Meter / Horizontal									
Frequency (MHz)	Reading-PK (dBuV)	Reading-AV (dBuV)	Correction Factor (dB/m)	Result-PK (dBuV/m)	Result-AV (dBuV/m)	Limit-PK (dBuV/m)	Limit-AV (dBuV/m)	Margin (dB)	Remark
1198.00	48.97	---	-6.82	42.15	---	74.00	54.00	-11.85	Peak
1598.00	45.20	---	-4.66	40.54	---	74.00	54.00	-13.46	Peak
2034.00	43.19	---	-2.96	40.23	---	74.00	54.00	-13.77	Peak
2500.00	47.40	---	-1.09	46.31	---	74.00	54.00	-7.69	Peak
3240.00	42.81	---	0.86	43.67	---	74.00	54.00	-10.33	Peak
4815.00	41.28	---	5.51	46.79	---	74.00	54.00	-7.21	Peak
5700.00	42.10	---	7.35	49.45	---	74.00	54.00	-4.55	Peak

966 Chamber_A at 3Meter / Vertical									
Frequency (MHz)	Reading-PK (dBuV)	Reading-AV (dBuV)	Correction Factor (dB/m)	Result-PK (dBuV/m)	Result-AV (dBuV/m)	Limit-PK (dBuV/m)	Limit-AV (dBuV/m)	Margin (dB)	Remark
1198.00	50.93	---	-6.82	44.11	---	74.00	54.00	-9.89	Peak
1464.00	45.29	---	-5.25	40.03	---	74.00	54.00	-13.97	Peak
1600.00	47.99	---	-4.65	43.34	---	74.00	54.00	-10.66	Peak
2360.00	45.20	---	-1.65	43.55	---	74.00	54.00	-10.45	Peak
2502.00	46.00	---	-1.08	44.91	---	74.00	54.00	-9.09	Peak
3750.00	43.06	---	2.02	45.09	---	74.00	54.00	-8.91	Peak
5025.00	41.51	---	6.15	47.66	---	74.00	54.00	-6.34	Peak
6240.00	41.13	---	8.82	49.94	---	74.00	54.00	-4.06	Peak

Remark:

1. Measuring frequencies from 1 GHz to the 10th harmonic of highest fundamental frequency.
2. Average test would be performed if the peak result were greater than the average limit.
3. Data of measurement within this frequency range shown " --- " in the table above means the reading of emissions are attenuated more than 20dB below the permissible limits or the field strength is too small to be measured.
4. Measurements above show only up to 6 maximum emissions noted, or would be lesser, with " N/A " remark, if no specific emissions from the EUT are recorded (ie: margin>20dB from the applicable limit) and considered that's already beyond the background noise floor.
5. Result = Reading + Correction Factor
Margin = Result - Limit
Remark Peak = Result(PK) - Limit(AV)
Remark AVG = Result(AV) - Limit(AV)



Product Name	802.11bgn WLAN + Bluetooth Mini Card	Test By	Rueyyan Lin
Test Model	BCM943227HMB	Test Date	2012/02/22
Test Mode	Bluetooth / 8-DPSK TX / CH Low	Temp. & Humidity	24°C, 58%

966 Chamber_A at 3Meter / Horizontal									
Frequency (MHz)	Reading-PK (dBuV)	Reading-AV (dBuV)	Correction Factor (dB/m)	Result-PK (dBuV/m)	Result-AV (dBuV/m)	Limit-PK (dBuV/m)	Limit-AV (dBuV/m)	Margin (dB)	Remark
1198.00	48.36	---	-6.82	41.55	---	74.00	54.00	-12.45	Peak
1590.00	44.63	---	-4.69	39.94	---	74.00	54.00	-14.06	Peak
1702.00	44.79	---	-4.26	40.53	---	74.00	54.00	-13.47	Peak
2504.00	47.90	---	-1.08	46.83	---	74.00	54.00	-7.17	Peak
3255.00	42.97	---	0.88	43.85	---	74.00	54.00	-10.15	Peak
4965.00	41.73	---	6.00	47.72	---	74.00	54.00	-6.28	Peak
6135.00	41.87	---	8.43	50.31	---	74.00	54.00	-3.69	Peak

966 Chamber_A at 3Meter / Vertical									
Frequency (MHz)	Reading-PK (dBuV)	Reading-AV (dBuV)	Correction Factor (dB/m)	Result-PK (dBuV/m)	Result-AV (dBuV/m)	Limit-PK (dBuV/m)	Limit-AV (dBuV/m)	Margin (dB)	Remark
1198.00	51.04	---	-6.82	44.22	---	74.00	54.00	-9.78	Peak
1326.00	47.50	---	-6.06	41.44	---	74.00	54.00	-12.56	Peak
1460.00	46.66	---	-5.28	41.38	---	74.00	54.00	-12.62	Peak
1602.00	48.82	---	-4.64	44.18	---	74.00	54.00	-9.82	Peak
2504.00	46.89	---	-1.08	45.81	---	74.00	54.00	-8.19	Peak
3330.00	43.16	---	0.97	44.13	---	74.00	54.00	-9.87	Peak
4965.00	41.34	---	6.00	47.34	---	74.00	54.00	-6.66	Peak
6135.00	41.78	---	8.43	50.22	---	74.00	54.00	-3.78	Peak

Remark:

1. Measuring frequencies from 1 GHz to the 10th harmonic of highest fundamental frequency.
2. Average test would be performed if the peak result were greater than the average limit.
3. Data of measurement within this frequency range shown " --- " in the table above means the reading of emissions are attenuated more than 20dB below the permissible limits or the field strength is too small to be measured.
4. Measurements above show only up to 6 maximum emissions noted, or would be lesser, with " N/A " remark, if no specific emissions from the EUT are recorded (ie: margin>20dB from the applicable limit) and considered that's already beyond the background noise floor.
5. Result = Reading + Correction Factor
 Margin = Result - Limit
 Remark Peak = Result(PK) - Limit(AV)
 Remark AVG = Result(AV) - Limit(AV)



Product Name	802.11bgn WLAN + Bluetooth Mini Card	Test By	Rueyyan Lin
Test Model	BCM943227HMB	Test Date	2012/02/22
Test Mode	Bluetooth / 8-DPSK TX / CH Middle	Temp. & Humidity	24°C, 58%

966 Chamber_A at 3Meter / Horizontal

Frequency (MHz)	Reading-PK (dBuV)	Reading-AV (dBuV)	Correction Factor (dB/m)	Result-PK (dBuV/m)	Result-AV (dBuV/m)	Limit-PK (dBuV/m)	Limit-AV (dBuV/m)	Margin (dB)	Remark
1196.00	48.35	---	-6.83	41.52	---	74.00	54.00	-12.48	Peak
1700.00	44.74	---	-4.26	40.48	---	74.00	54.00	-13.52	Peak
2500.00	47.60	---	-1.09	46.51	---	74.00	54.00	-7.49	Peak
2768.00	43.43	---	-0.20	43.23	---	74.00	54.00	-10.77	Peak
3330.00	42.62	---	0.97	43.59	---	74.00	54.00	-10.41	Peak
4875.00	41.05	---	5.71	46.76	---	74.00	54.00	-7.24	Peak
6450.00	41.50	---	9.59	51.08	---	74.00	54.00	-2.92	Peak

966 Chamber_A at 3Meter / Vertical

Frequency (MHz)	Reading-PK (dBuV)	Reading-AV (dBuV)	Correction Factor (dB/m)	Result-PK (dBuV/m)	Result-AV (dBuV/m)	Limit-PK (dBuV/m)	Limit-AV (dBuV/m)	Margin (dB)	Remark
1198.00	50.43	---	-6.82	43.62	---	74.00	54.00	-10.38	Peak
1604.00	48.56	---	-4.64	43.93	---	74.00	54.00	-10.07	Peak
2320.00	45.52	---	-1.81	43.70	---	74.00	54.00	-10.30	Peak
2502.00	47.29	---	-1.08	46.20	---	74.00	54.00	-7.80	Peak
3300.00	42.96	---	0.94	43.89	---	74.00	54.00	-10.11	Peak
4995.00	42.35	---	6.09	48.45	---	74.00	54.00	-5.55	Peak
6165.00	40.95	---	8.54	49.50	---	74.00	54.00	-4.50	Peak

Remark:

1. Measuring frequencies from 1 GHz to the 10th harmonic of highest fundamental frequency.
2. Average test would be performed if the peak result were greater than the average limit.
3. Data of measurement within this frequency range shown " --- " in the table above means the reading of emissions are attenuated more than 20dB below the permissible limits or the field strength is too small to be measured.
4. Measurements above show only up to 6 maximum emissions noted, or would be lesser, with " N/A " remark, if no specific emissions from the EUT are recorded (ie: margin>20dB from the applicable limit) and considered that's already beyond the background noise floor.
5. Result = Reading + Correction Factor
Margin = Result - Limit
Remark Peak = Result(PK) - Limit(AV)
Remark AVG = Result(AV) - Limit(AV)



Product Name	802.11bgn WLAN + Bluetooth Mini Card	Test By	Rueyyan Lin
Test Model	BCM943227HMB	Test Date	2012/02/22
Test Mode	Bluetooth / 8-DPSK TX / CH High	Temp. & Humidity	24°C, 58%

966 Chamber_A at 3Meter / Horizontal									
Frequency (MHz)	Reading-PK (dBuV)	Reading-AV (dBuV)	Correction Factor (dB/m)	Result-PK (dBuV/m)	Result-AV (dBuV/m)	Limit-PK (dBuV/m)	Limit-AV (dBuV/m)	Margin (dB)	Remark
1196.00	48.71	---	-6.83	41.88	---	74.00	54.00	-12.12	Peak
1700.00	45.44	---	-4.26	41.17	---	74.00	54.00	-12.83	Peak
2212.00	42.68	---	-2.25	40.43	---	74.00	54.00	-13.57	Peak
2500.00	46.82	---	-1.09	45.73	---	74.00	54.00	-8.27	Peak
3675.00	42.19	---	1.77	43.96	---	74.00	54.00	-10.04	Peak
4710.00	41.59	---	5.18	46.77	---	74.00	54.00	-7.23	Peak
6030.00	41.63	---	8.05	49.68	---	74.00	54.00	-4.32	Peak

966 Chamber_A at 3Meter / Vertical									
Frequency (MHz)	Reading-PK (dBuV)	Reading-AV (dBuV)	Correction Factor (dB/m)	Result-PK (dBuV/m)	Result-AV (dBuV/m)	Limit-PK (dBuV/m)	Limit-AV (dBuV/m)	Margin (dB)	Remark
1198.00	51.03	---	-6.82	44.22	---	74.00	54.00	-9.78	Peak
1298.00	46.67	---	-6.23	40.44	---	74.00	54.00	-13.56	Peak
1604.00	50.98	---	-4.64	46.35	---	74.00	54.00	-7.65	Peak
2496.00	45.16	---	-1.11	44.05	---	74.00	54.00	-9.95	Peak
2600.00	44.44	---	-0.76	43.68	---	74.00	54.00	-10.32	Peak
3285.00	43.29	---	0.92	44.21	---	74.00	54.00	-9.79	Peak
4140.00	41.29	---	3.33	44.61	---	74.00	54.00	-9.39	Peak
4965.00	41.09	---	6.00	47.09	---	74.00	54.00	-6.91	Peak
6210.00	40.88	---	8.71	49.59	---	74.00	54.00	-4.41	Peak

Remark:

1. Measuring frequencies from 1 GHz to the 10th harmonic of highest fundamental frequency.
2. Average test would be performed if the peak result were greater than the average limit.
3. Data of measurement within this frequency range shown " --- " in the table above means the reading of emissions are attenuated more than 20dB below the permissible limits or the field strength is too small to be measured.
4. Measurements above show only up to 6 maximum emissions noted, or would be lesser, with " N/A " remark, if no specific emissions from the EUT are recorded (ie: margin>20dB from the applicable limit) and considered that's already beyond the background noise floor.
5. Result = Reading + Correction Factor
Margin = Result - Limit
Remark Peak = Result(PK) - Limit(AV)
Remark AVG = Result(AV) - Limit(AV)



Restricted Band Edges

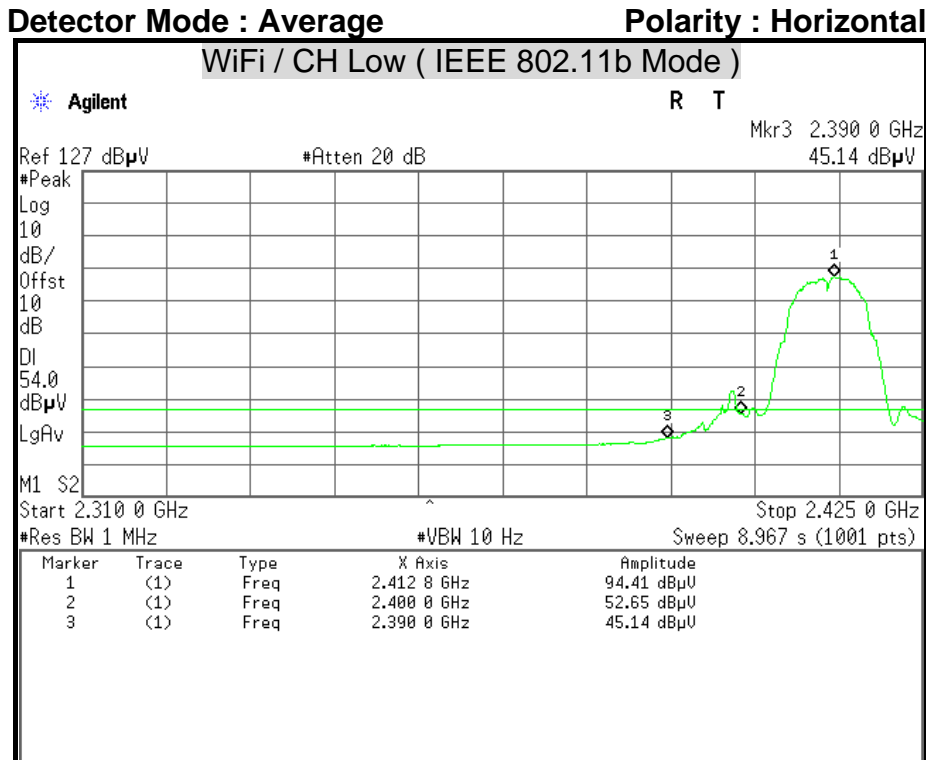
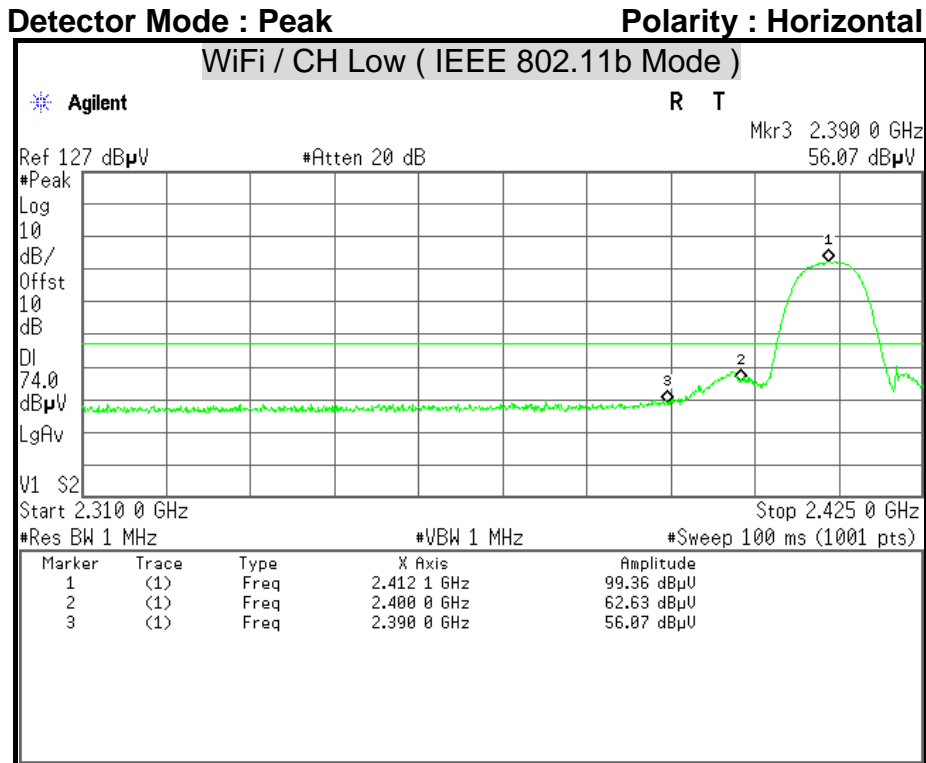



Detector Mode : Peak

Polarity : Vertical

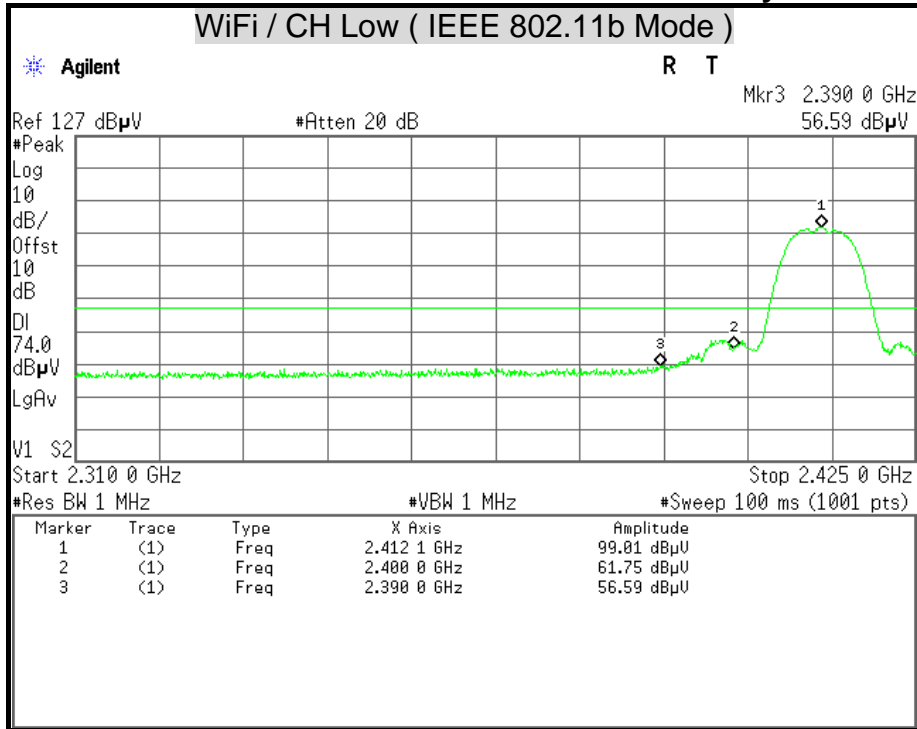

Detector Mode : Average

Polarity : Vertical

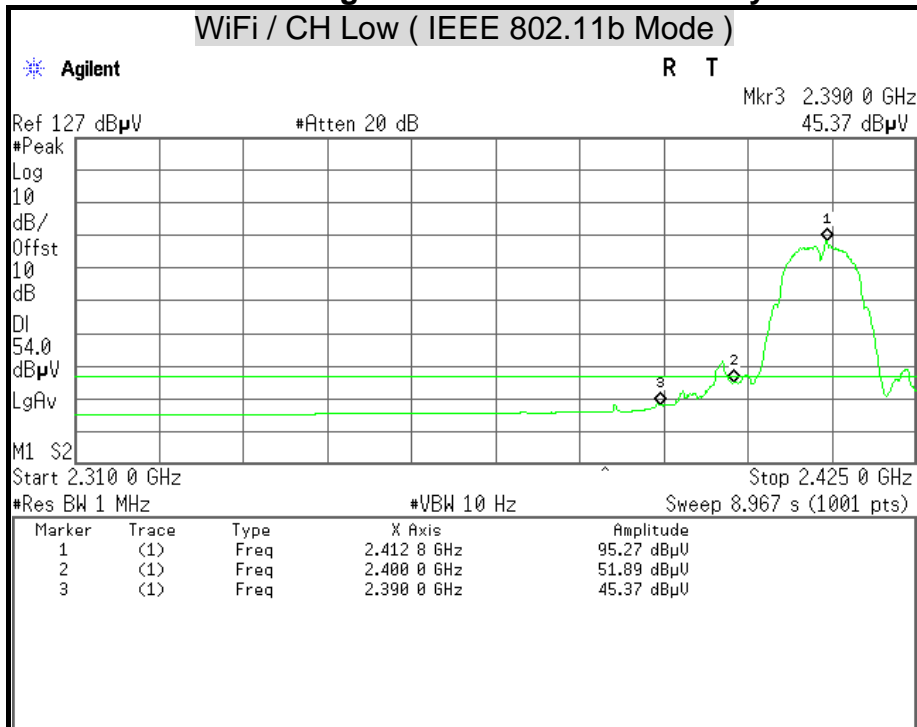



Detector Mode : Peak

Polarity : Horizontal

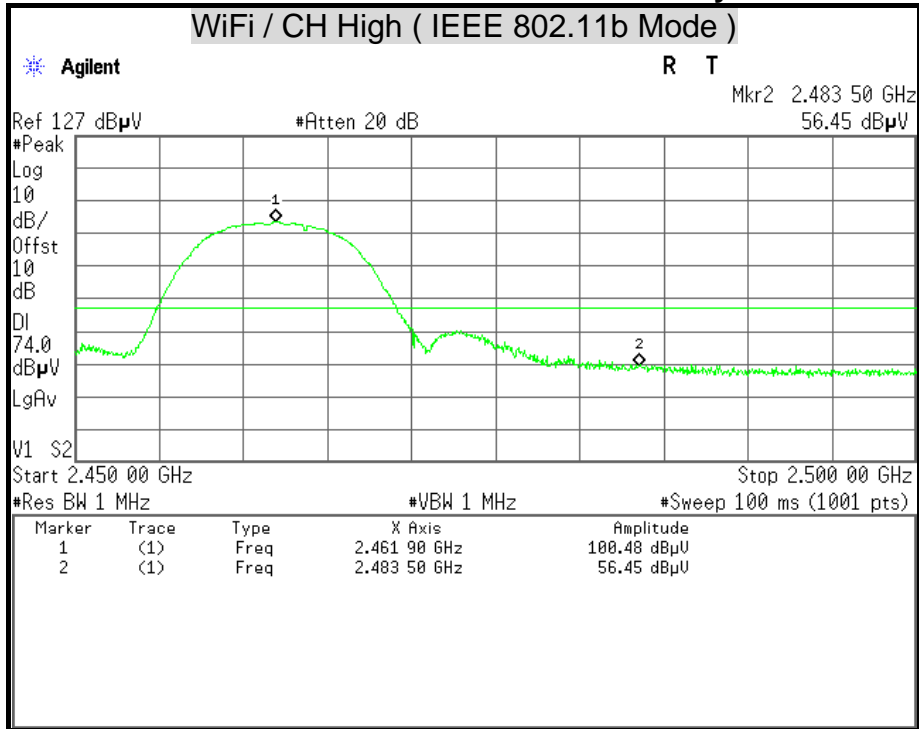

Detector Mode : Average

Polarity : Horizontal

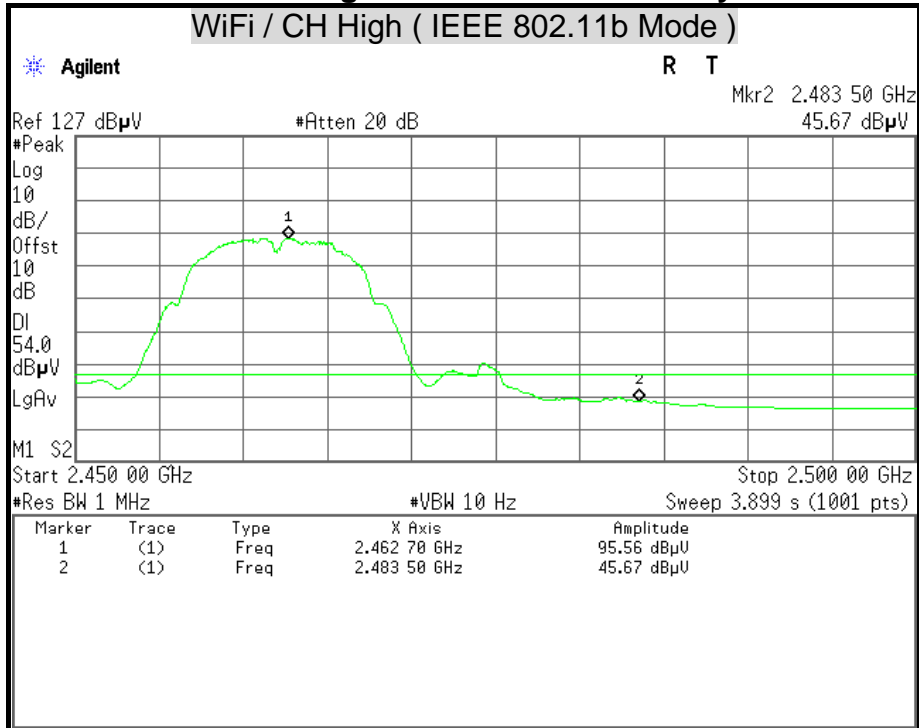



Detector Mode : Peak

Polarity : Vertical

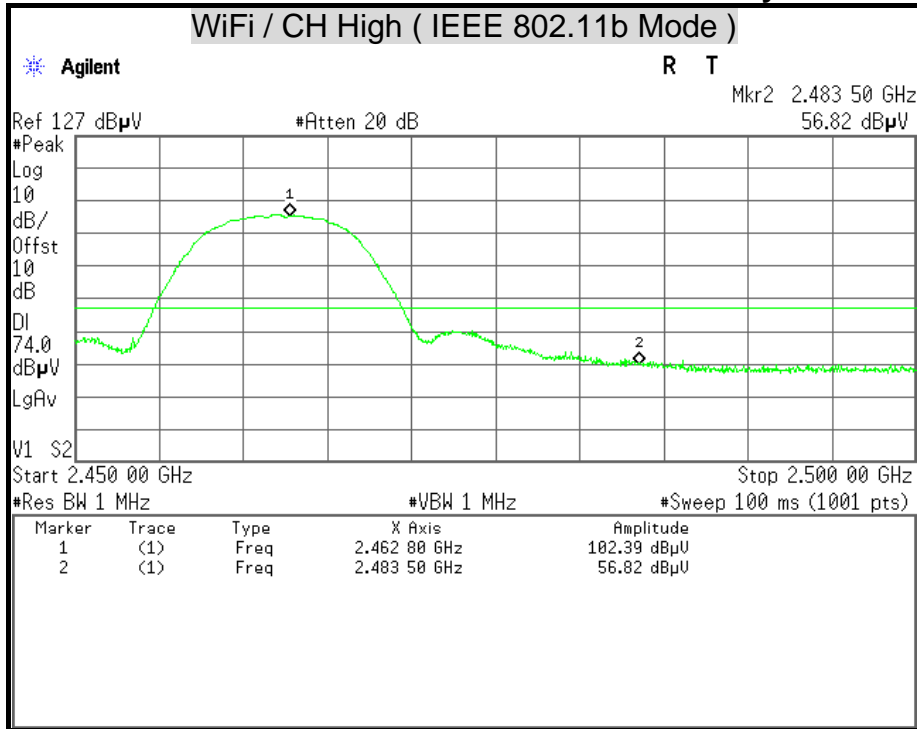

Detector Mode : Average

Polarity : Vertical

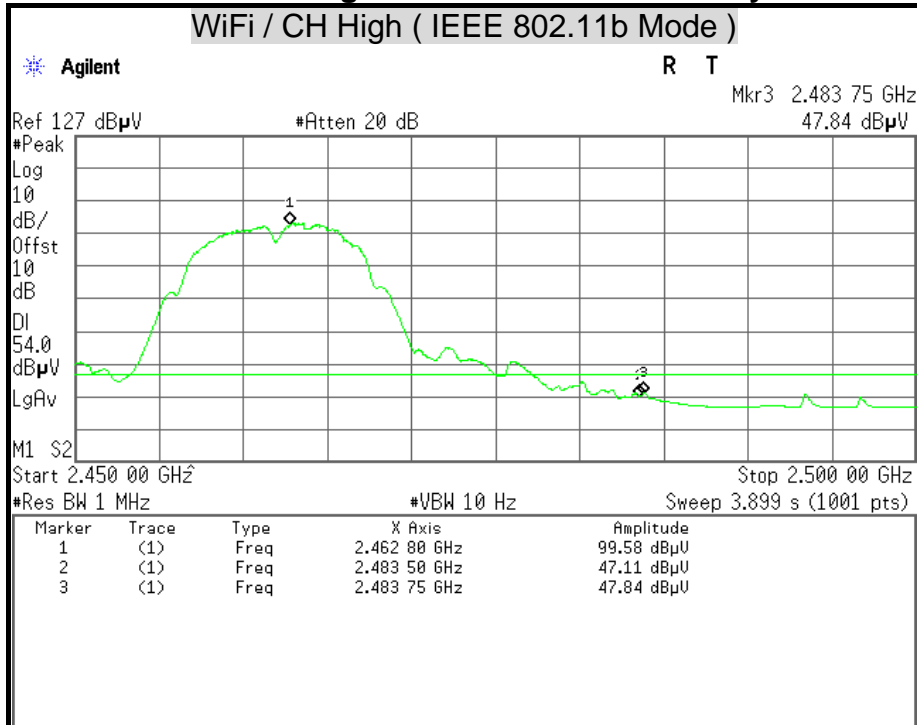



Detector Mode : Peak

Polarity : Horizontal

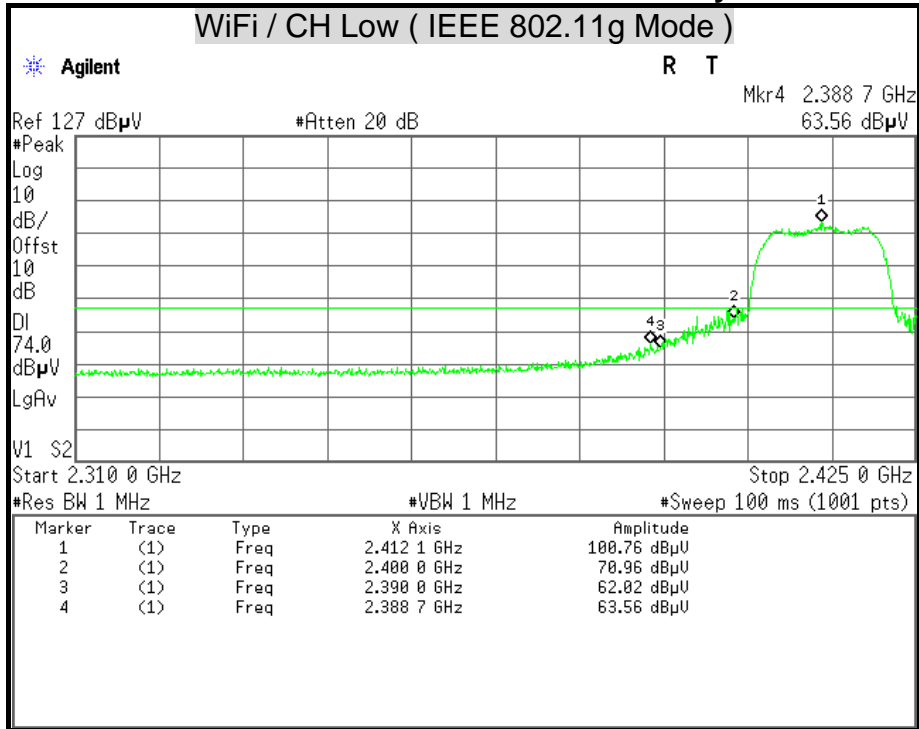

Detector Mode : Average

Polarity : Horizontal

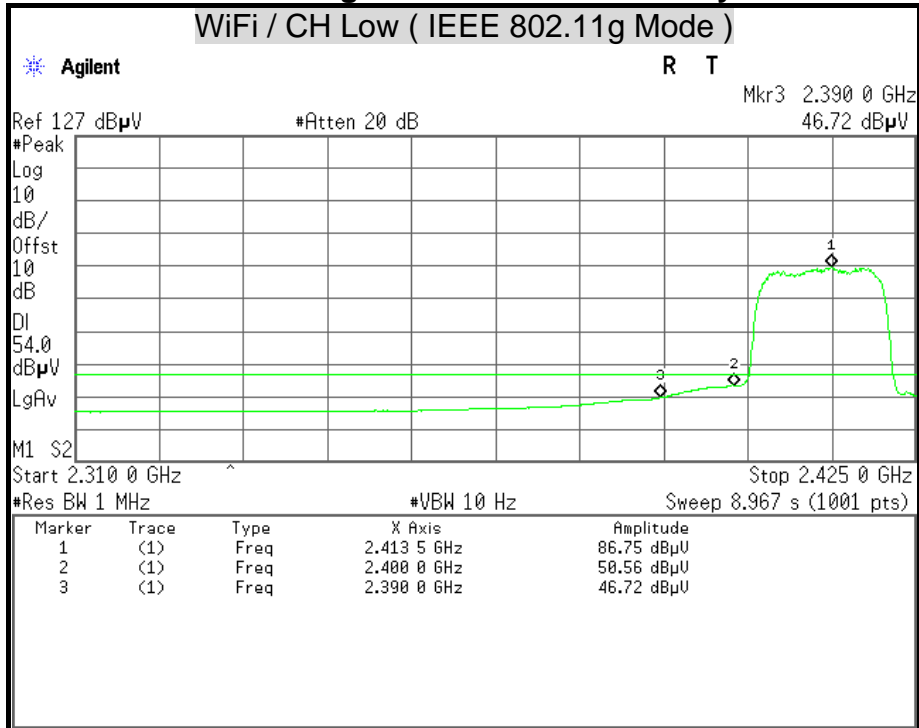



Detector Mode : Peak

Polarity : Vertical

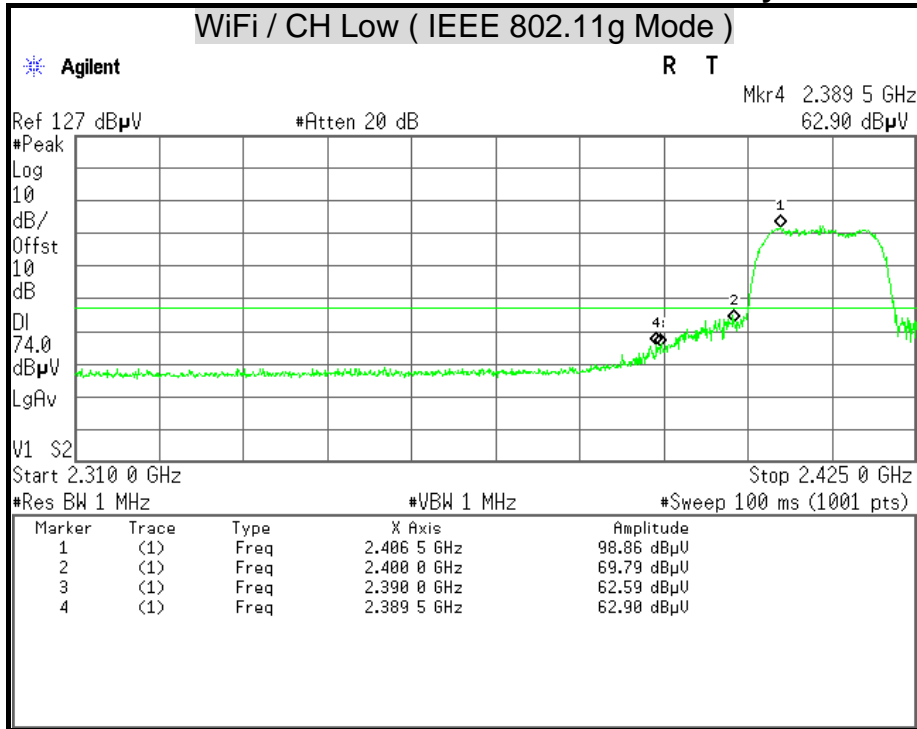

Detector Mode : Average

Polarity : Vertical

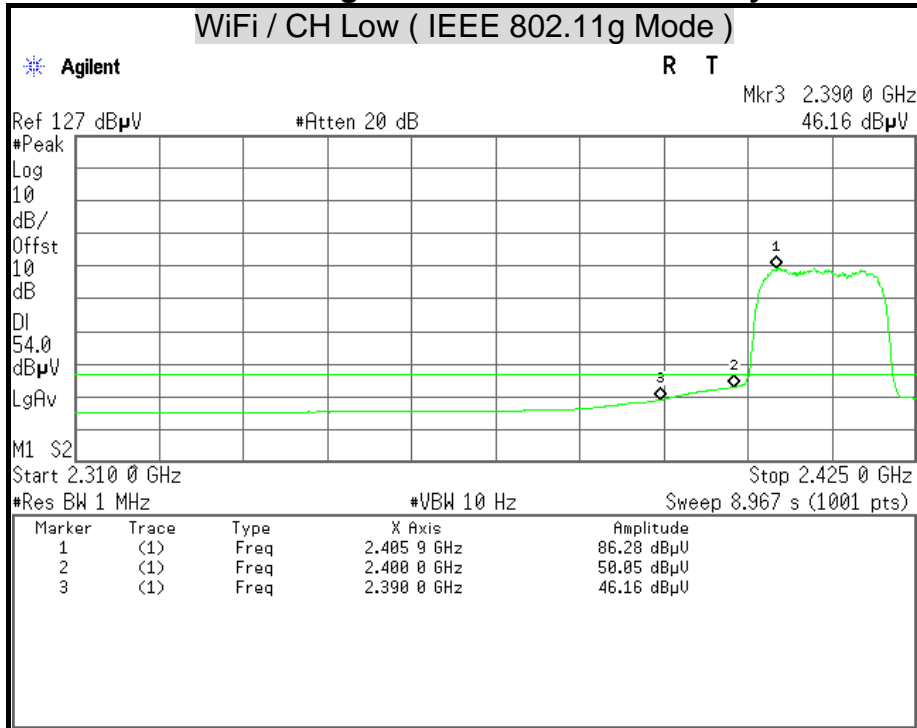



Detector Mode : Peak

Polarity : Horizontal

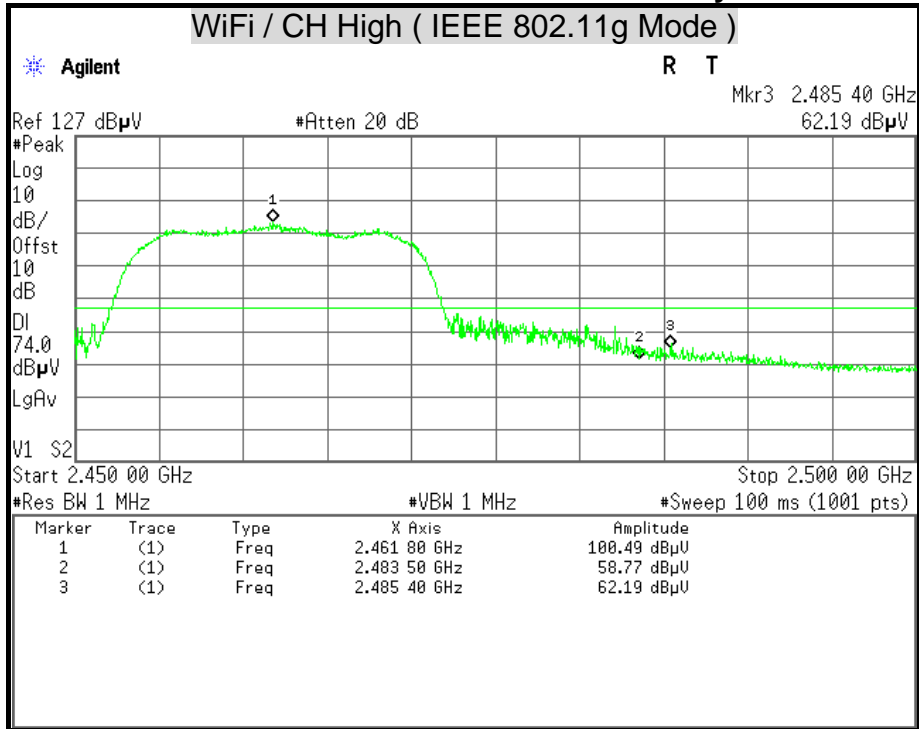

Detector Mode : Average

Polarity : Horizontal

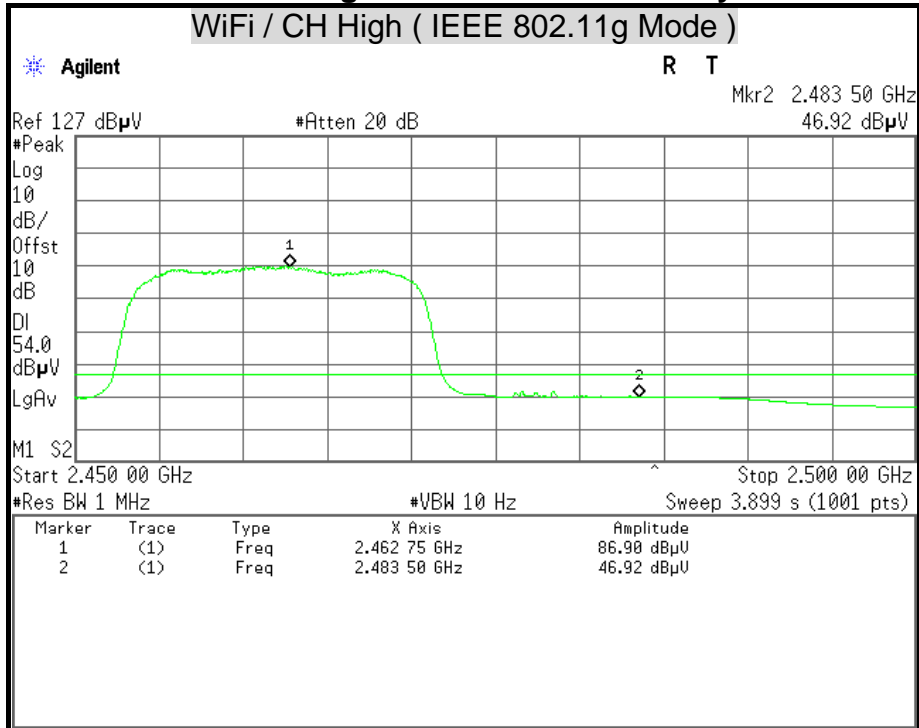



Detector Mode : Peak

Polarity : Vertical

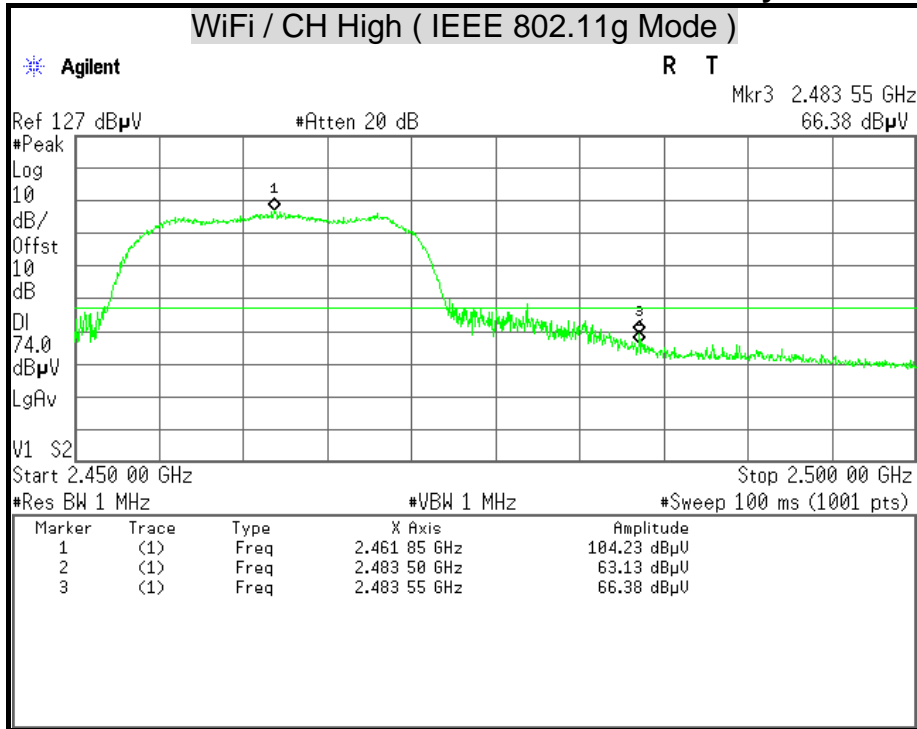

Detector Mode : Average

Polarity : Vertical

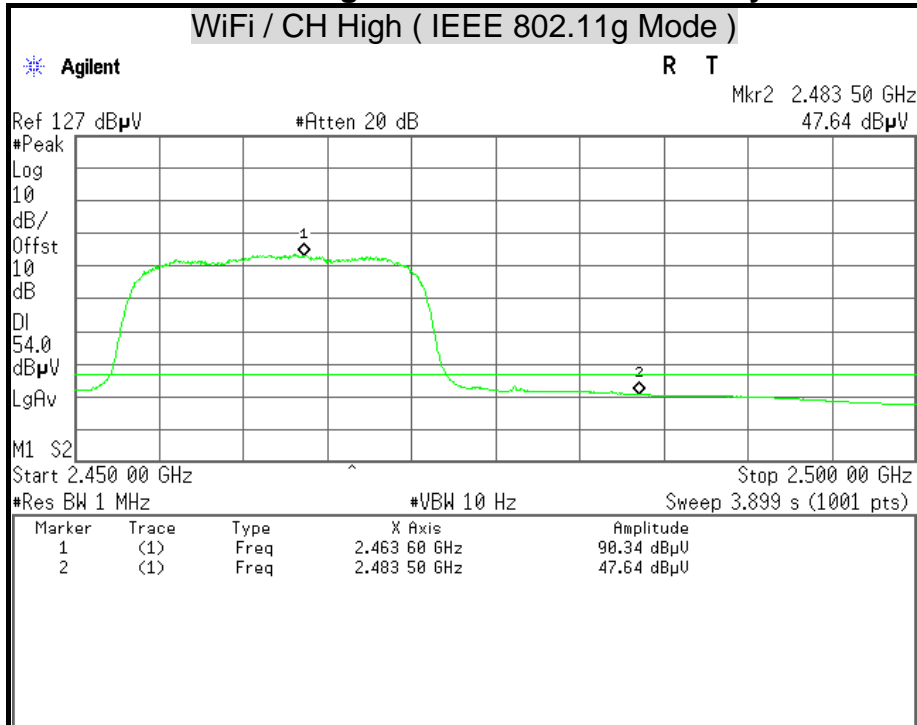



Detector Mode : Peak

Polarity : Horizontal

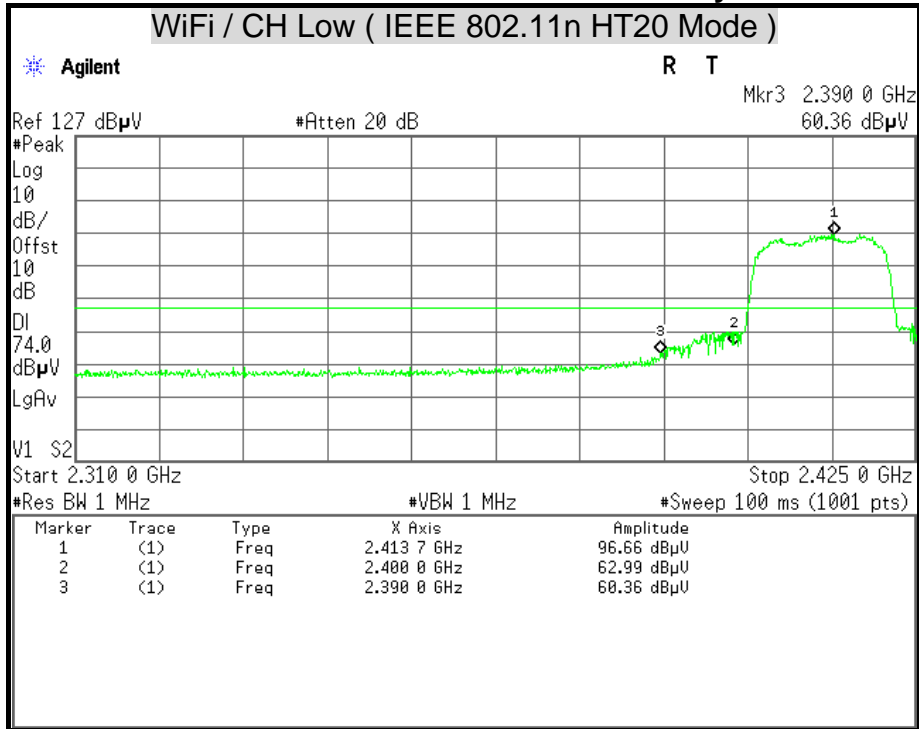

Detector Mode : Average

Polarity : Horizontal

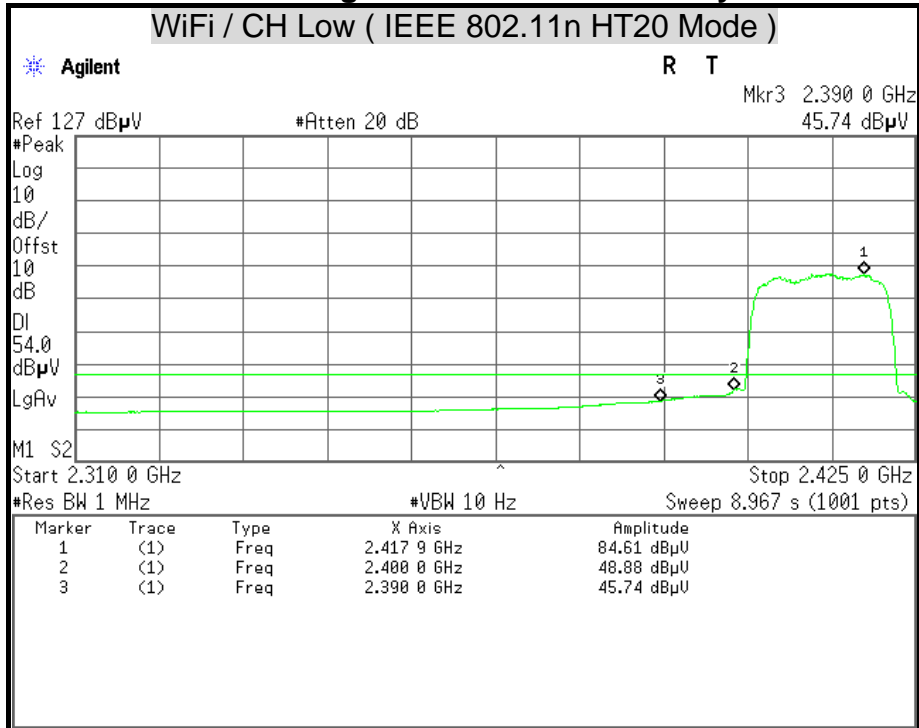



Detector Mode : Peak

Polarity : Vertical

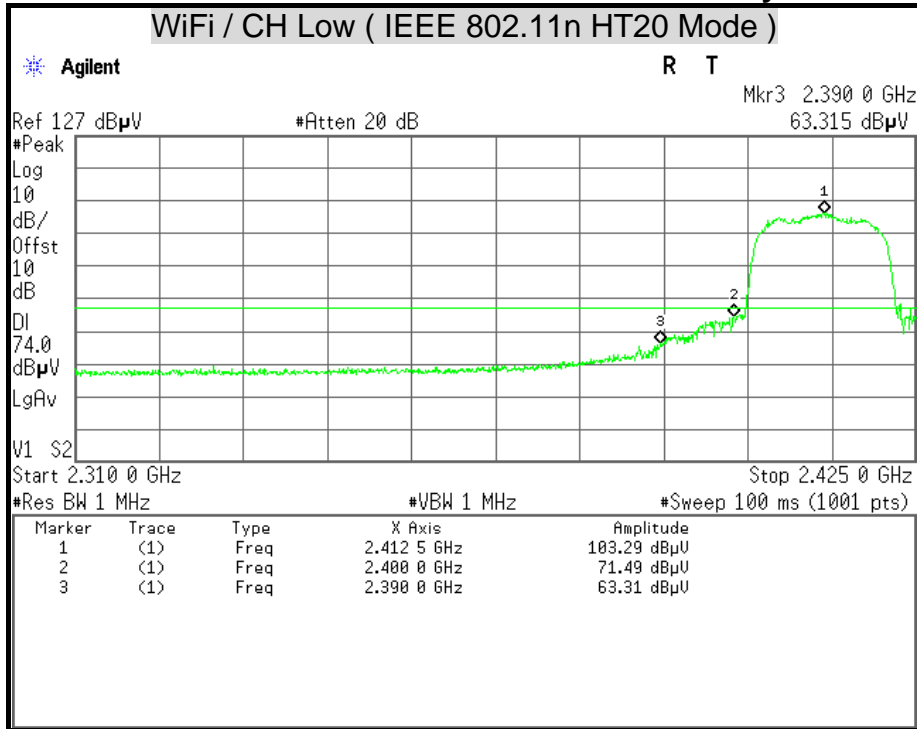

Detector Mode : Average

Polarity : Vertical

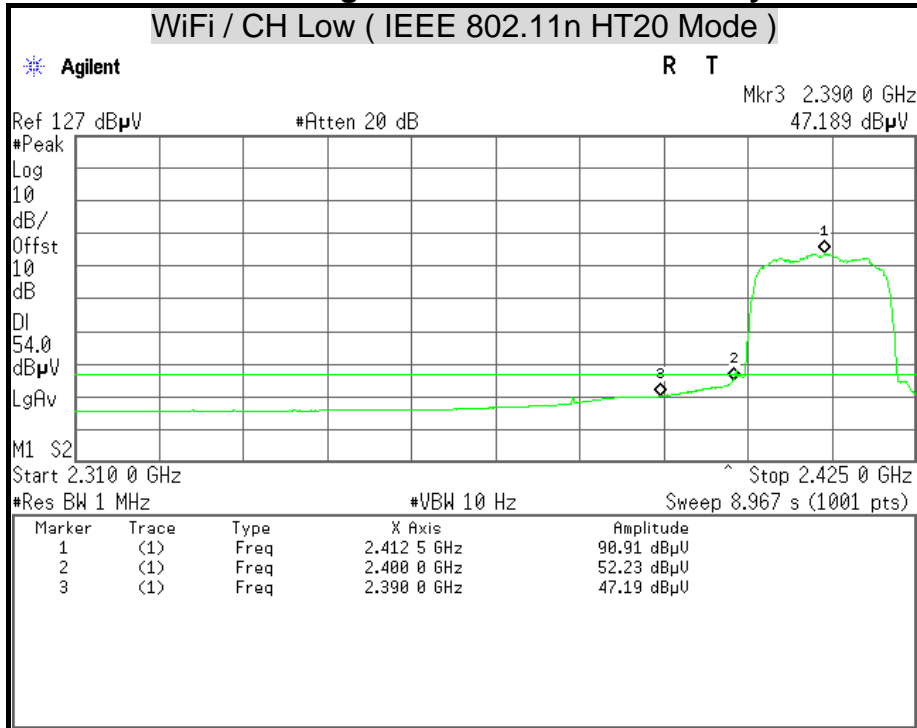



Detector Mode : Peak

Polarity : Horizontal

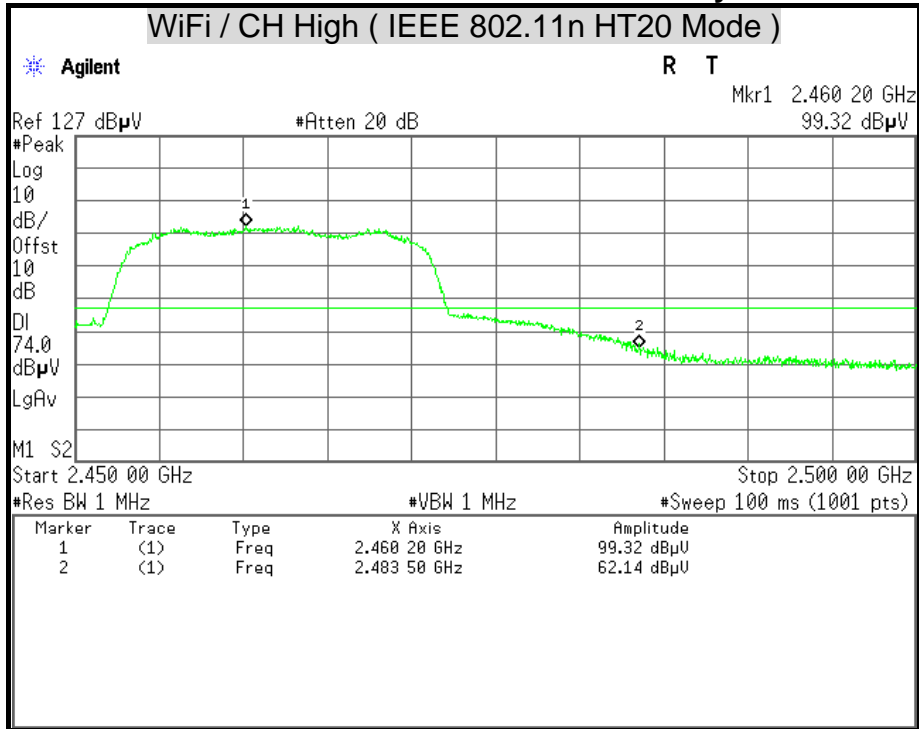

Detector Mode : Average

Polarity : Horizontal

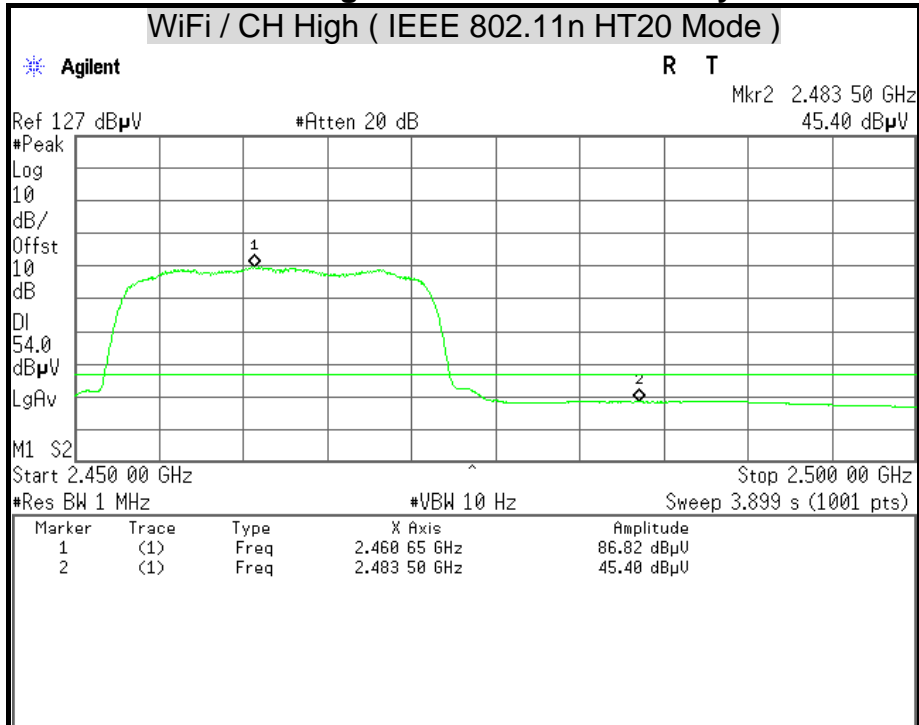



Detector Mode : Peak

Polarity : Vertical

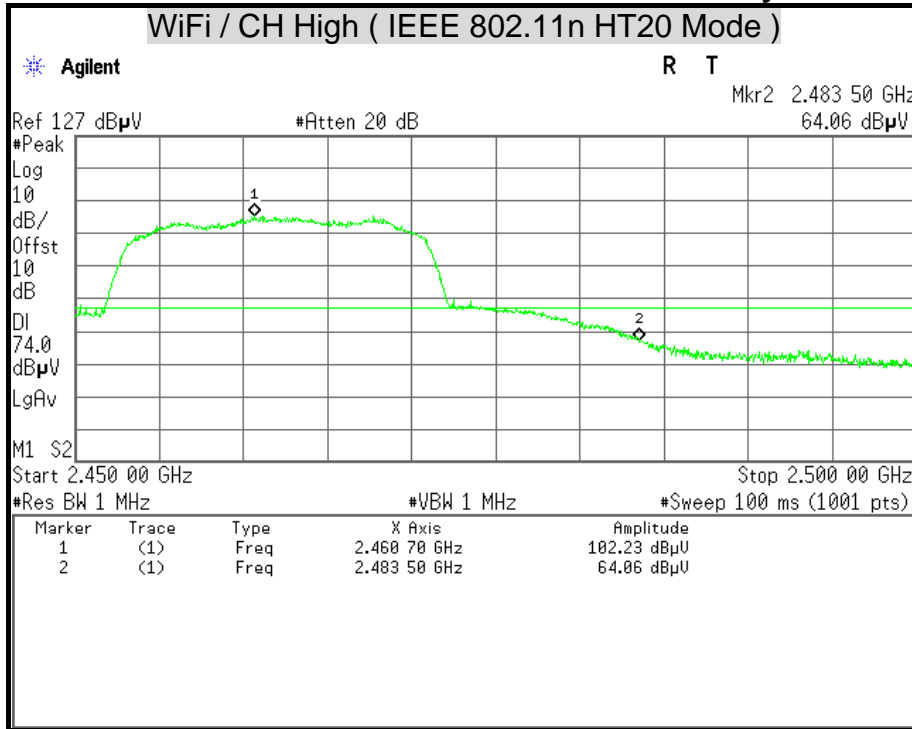

Detector Mode : Average

Polarity : Vertical

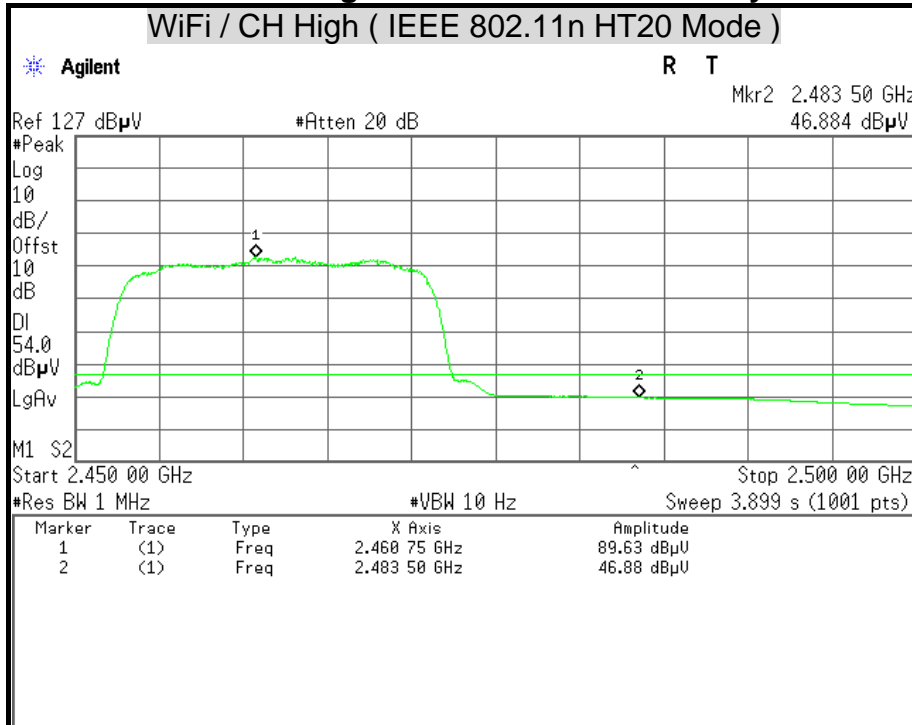



Detector Mode : Peak

Polarity : Horizontal

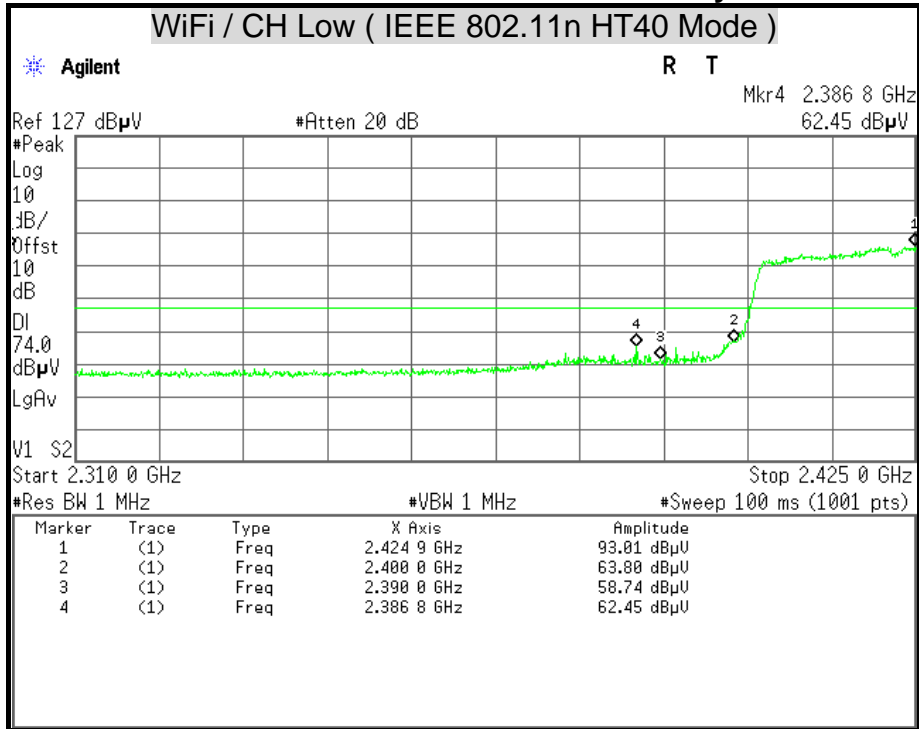

Detector Mode : Average

Polarity : Horizontal

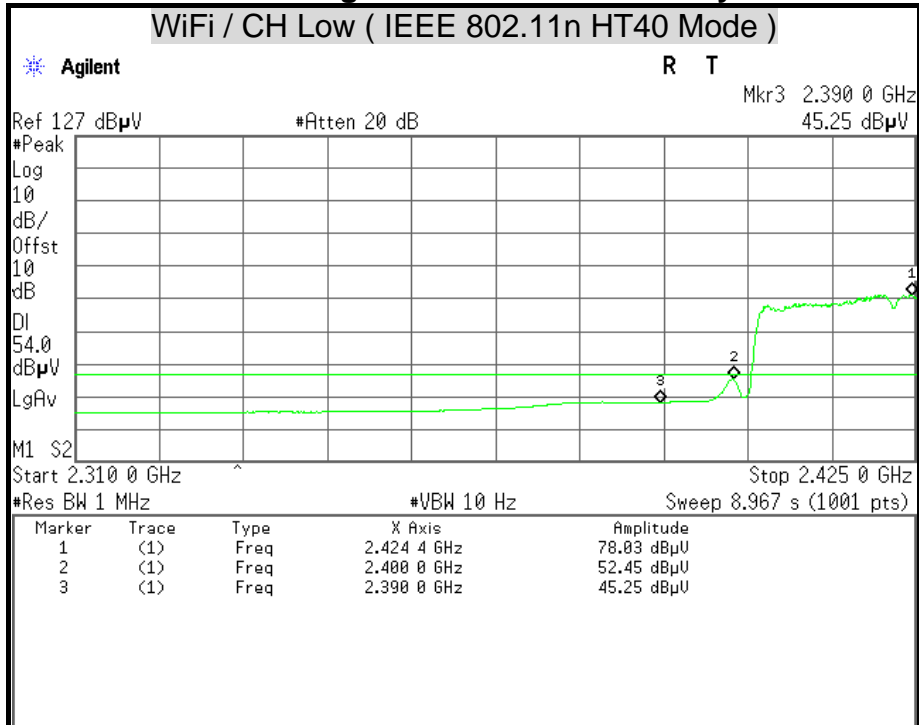



Detector Mode : Peak

Polarity : Vertical

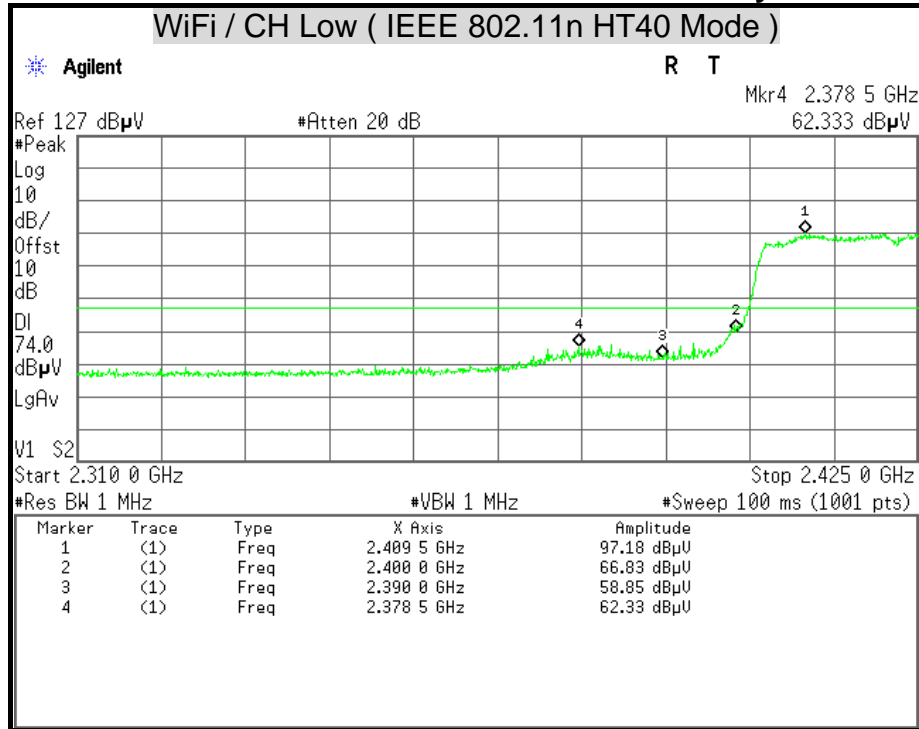

Detector Mode : Average

Polarity : Vertical

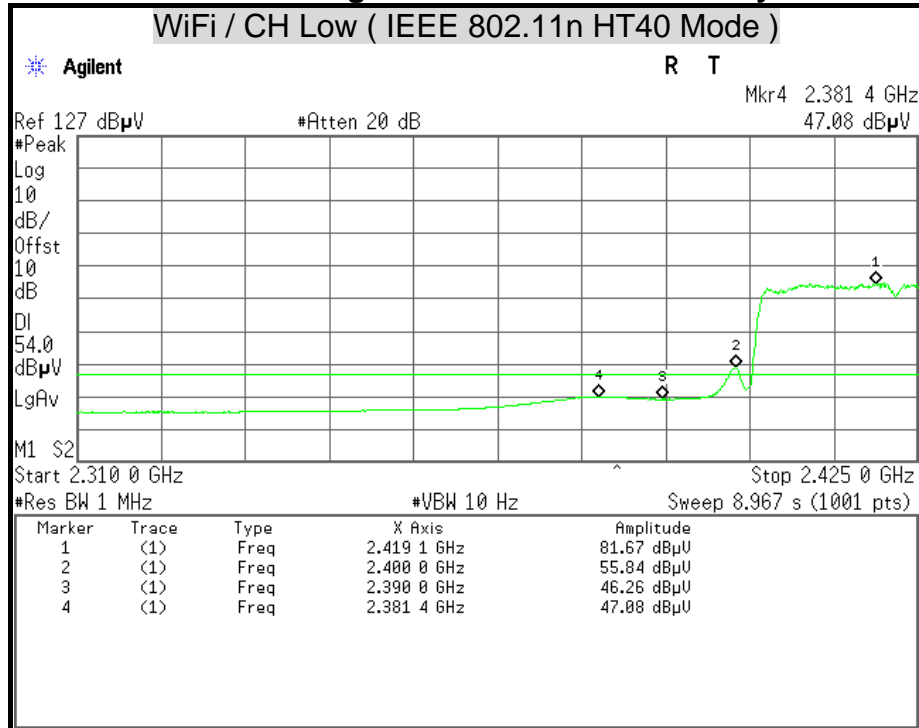



Detector Mode : Peak

Polarity : Horizontal

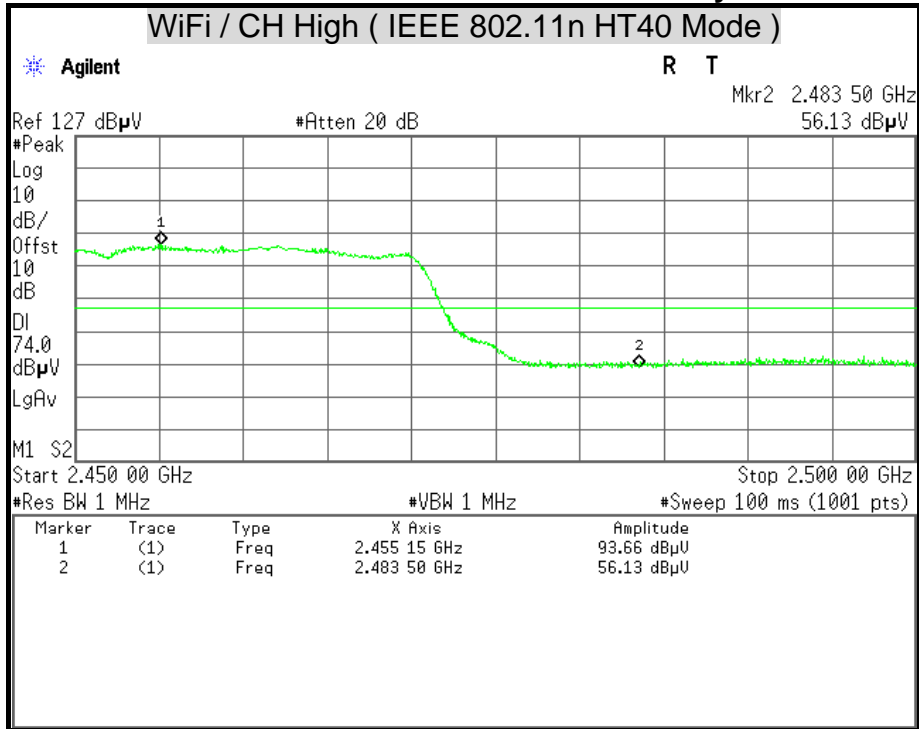

Detector Mode : Average

Polarity : Horizontal

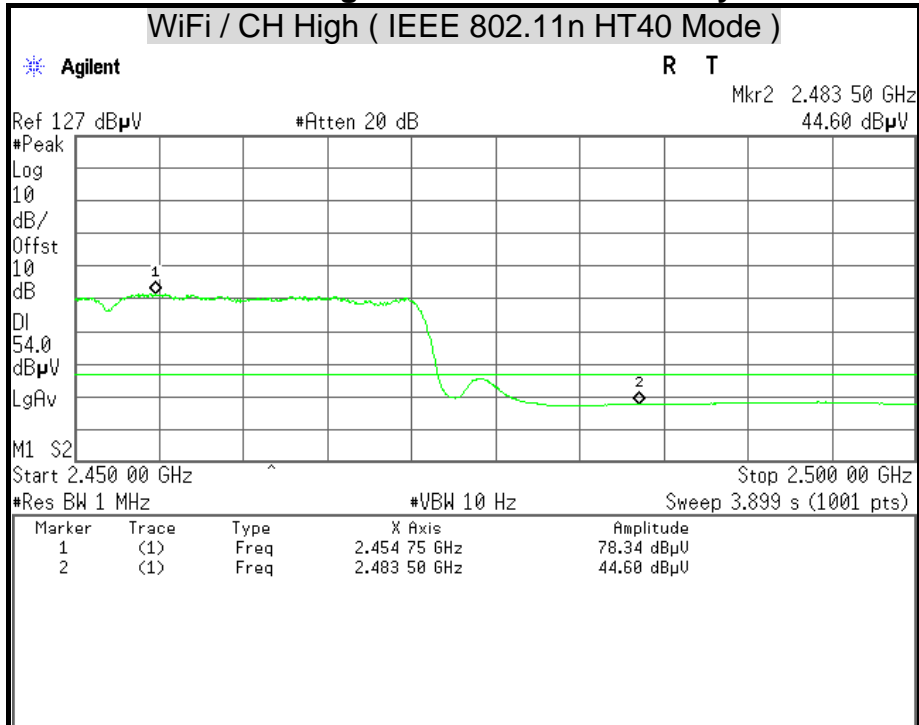



Detector Mode : Peak

Polarity : Vertical

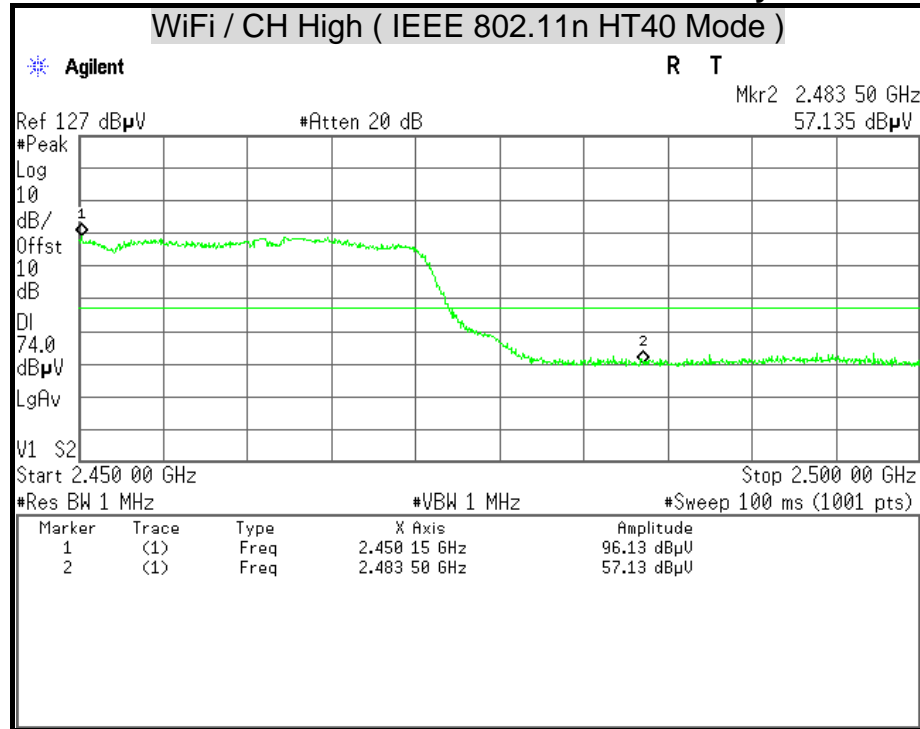

Detector Mode : Average

Polarity : Vertical

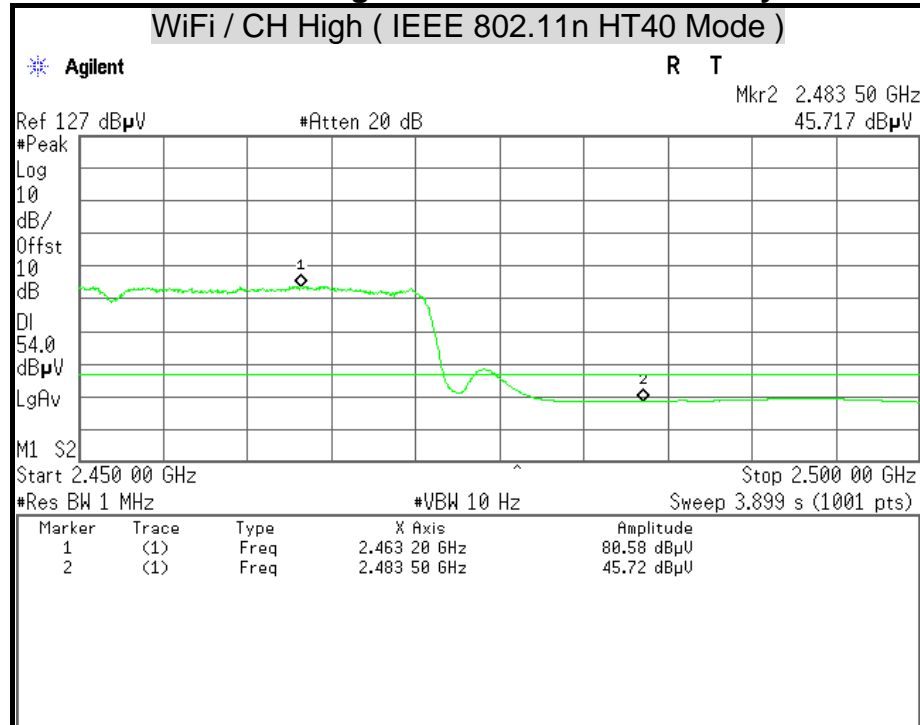



Detector Mode : Peak

Polarity : Horizontal

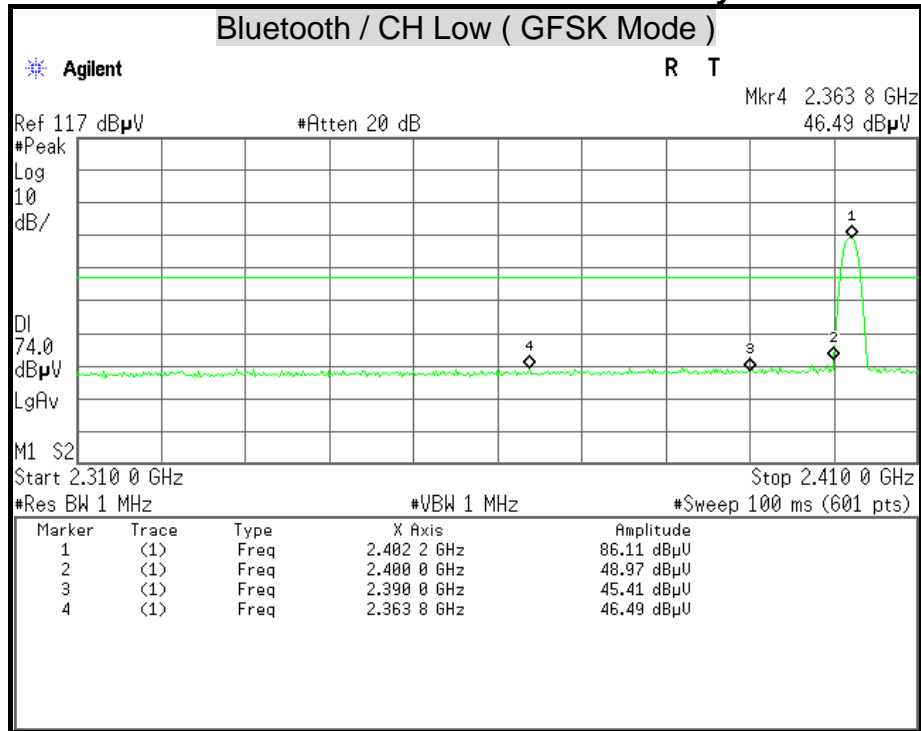

Detector Mode : Average

Polarity : Horizontal

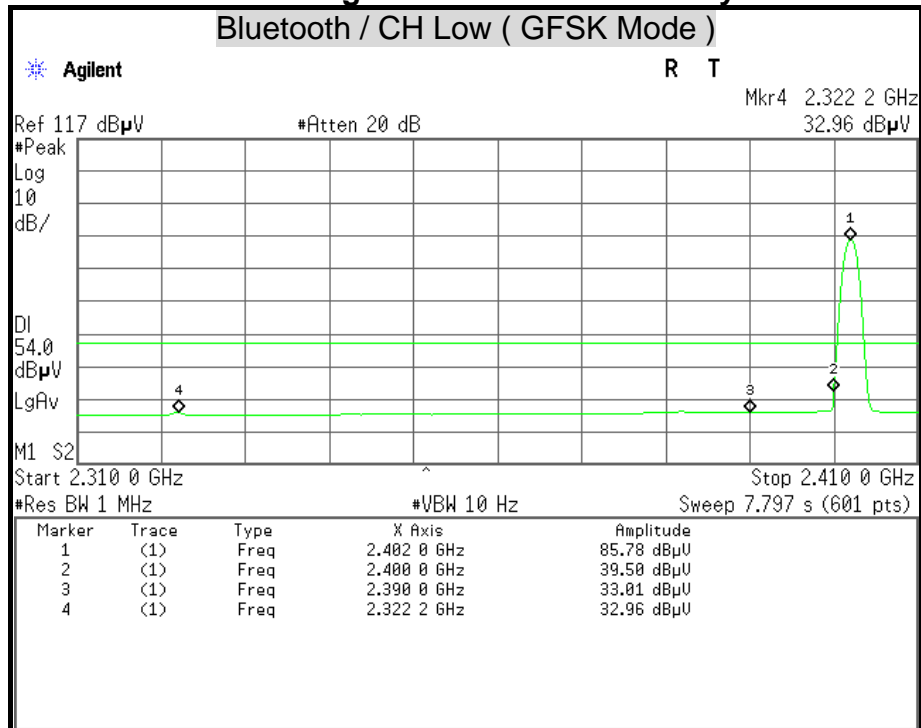



Detector Mode : Peak

Polarity : Vertical

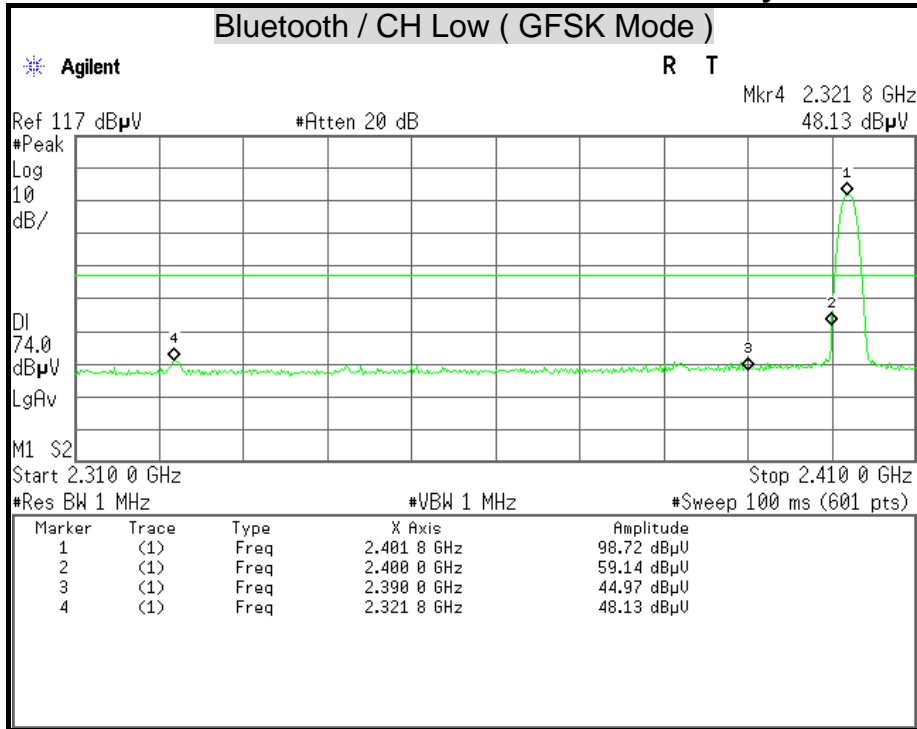

Detector Mode : Average

Polarity : Vertical

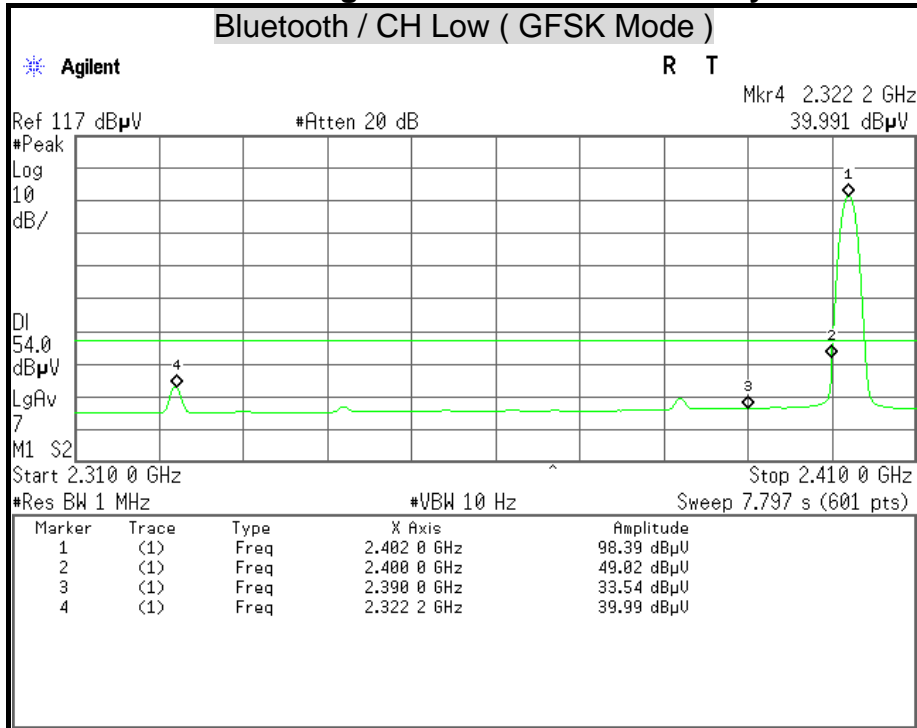



Detector Mode : Peak

Polarity : Horizontal

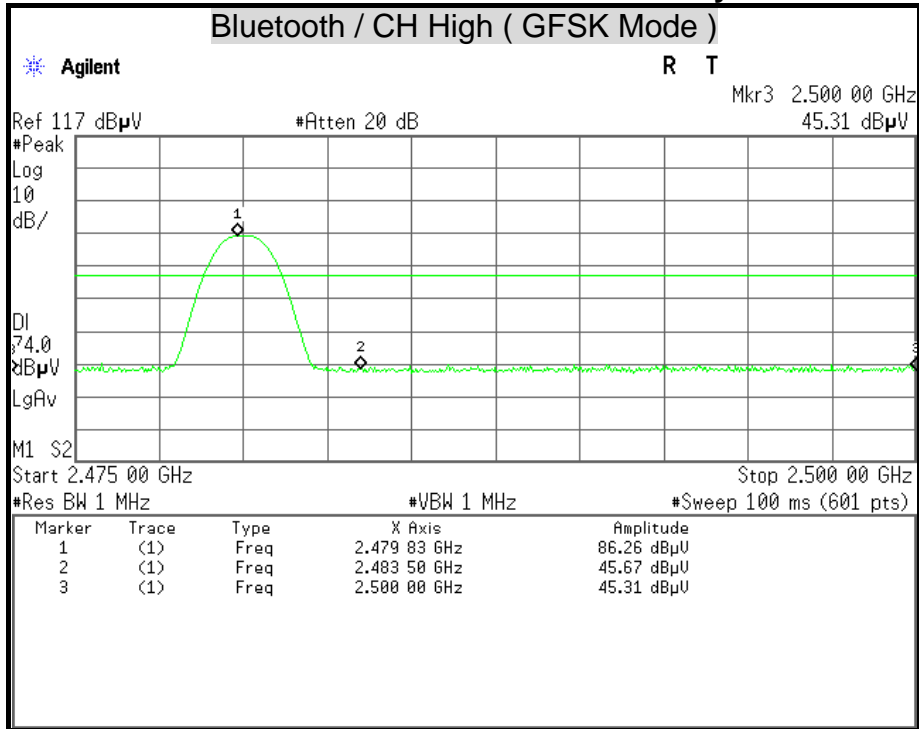

Detector Mode : Average

Polarity : Horizontal

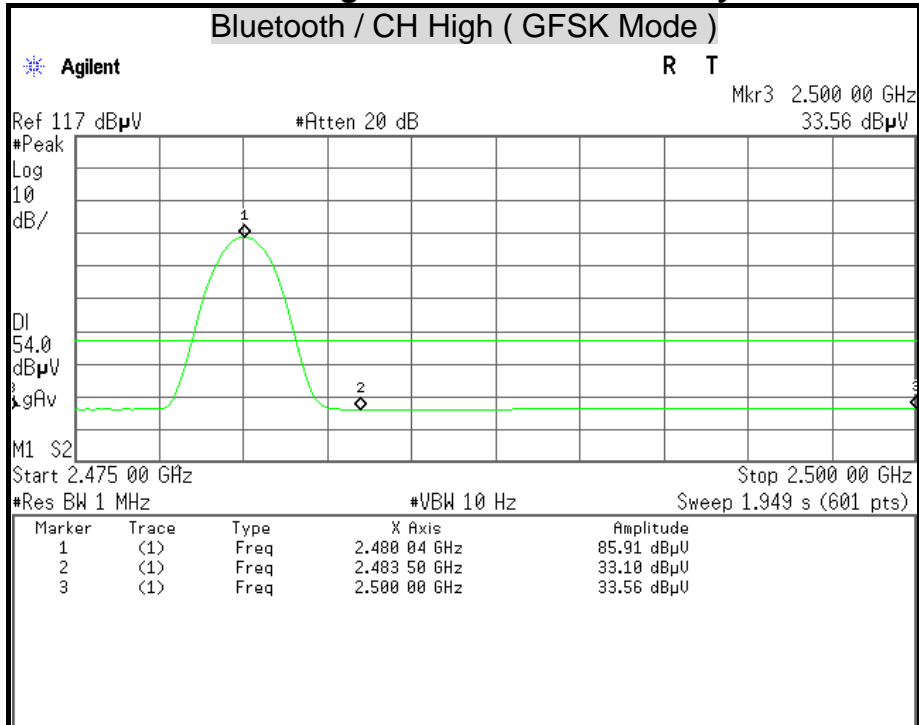



Detector Mode : Peak

Polarity : Vertical

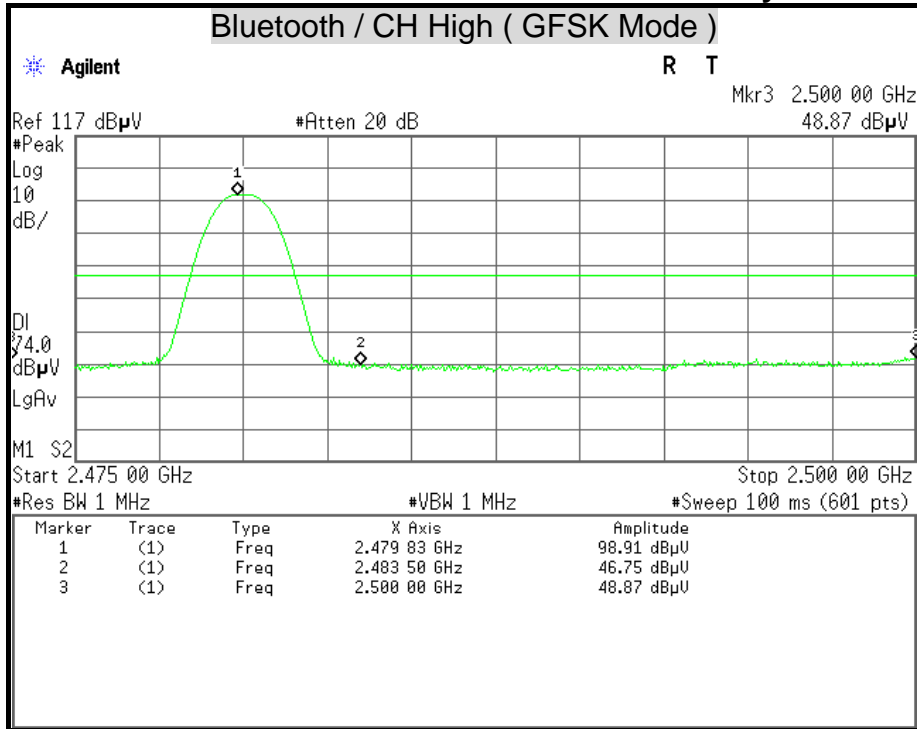

Detector Mode : Average

Polarity : Vertical

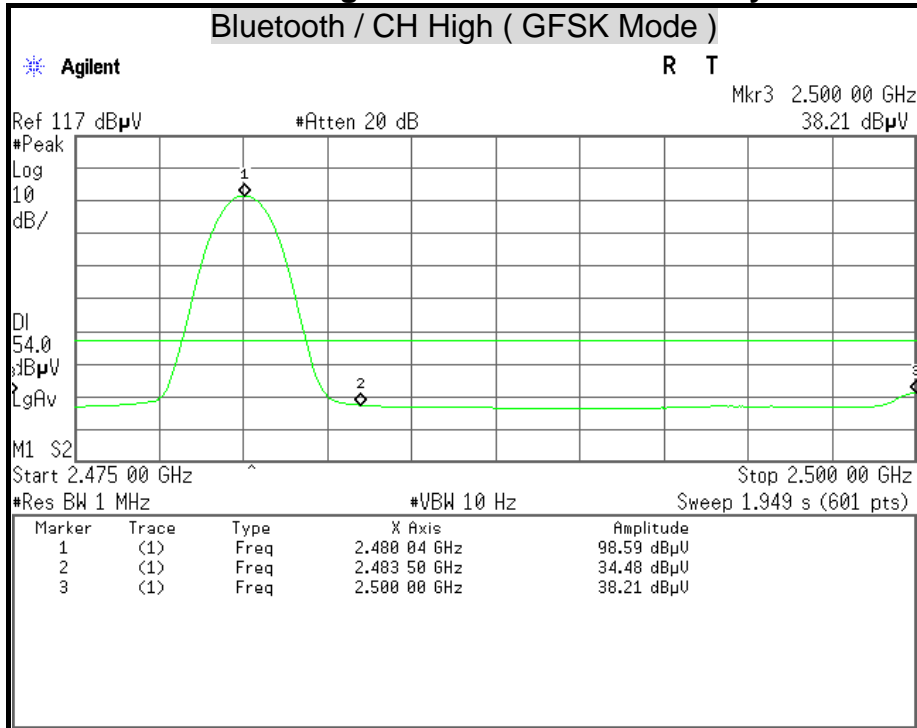



Detector Mode : Peak

Polarity : Horizontal

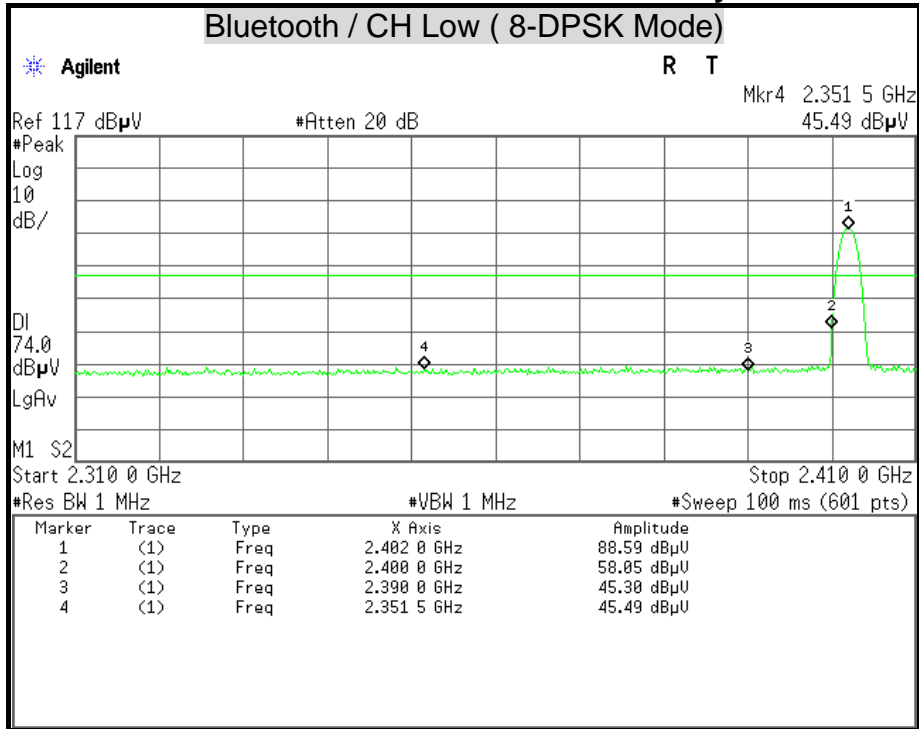

Detector Mode : Average

Polarity : Horizontal

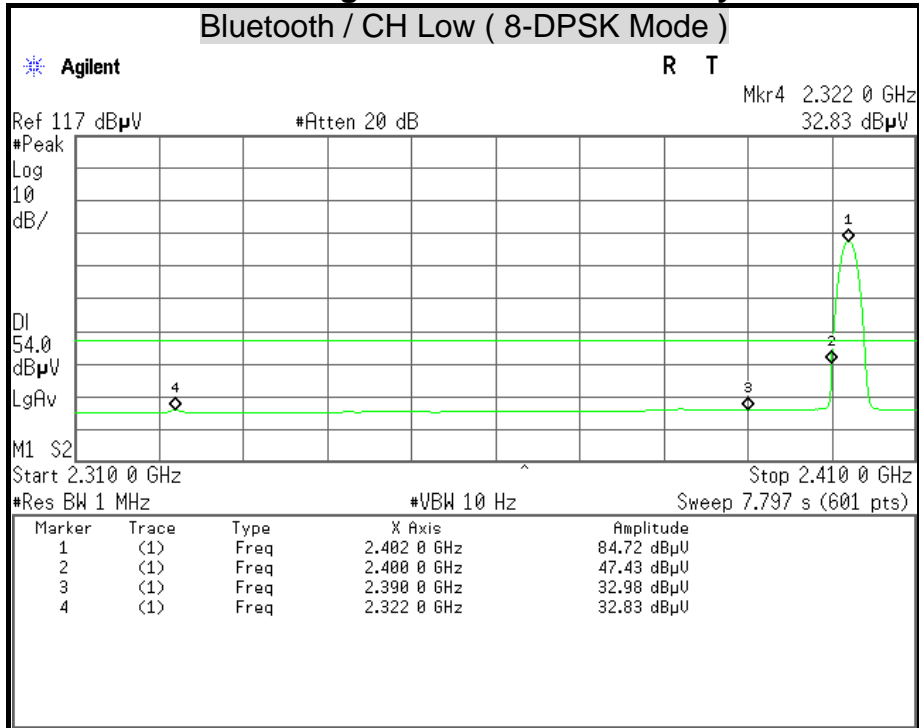



Detector Mode : Peak

Polarity : Vertical

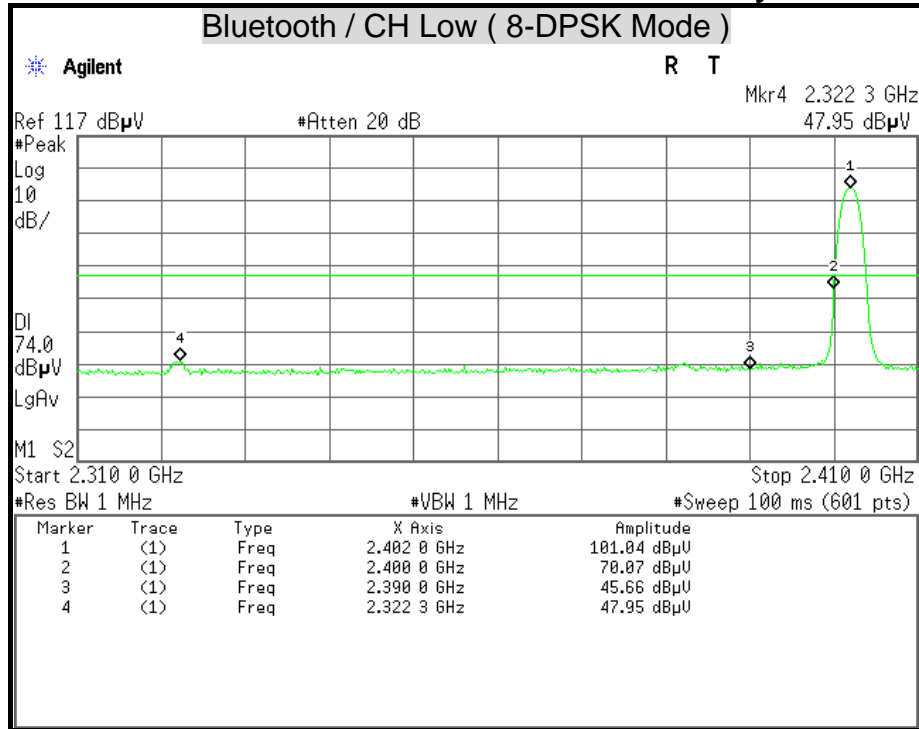

Detector Mode : Average

Polarity : Vertical

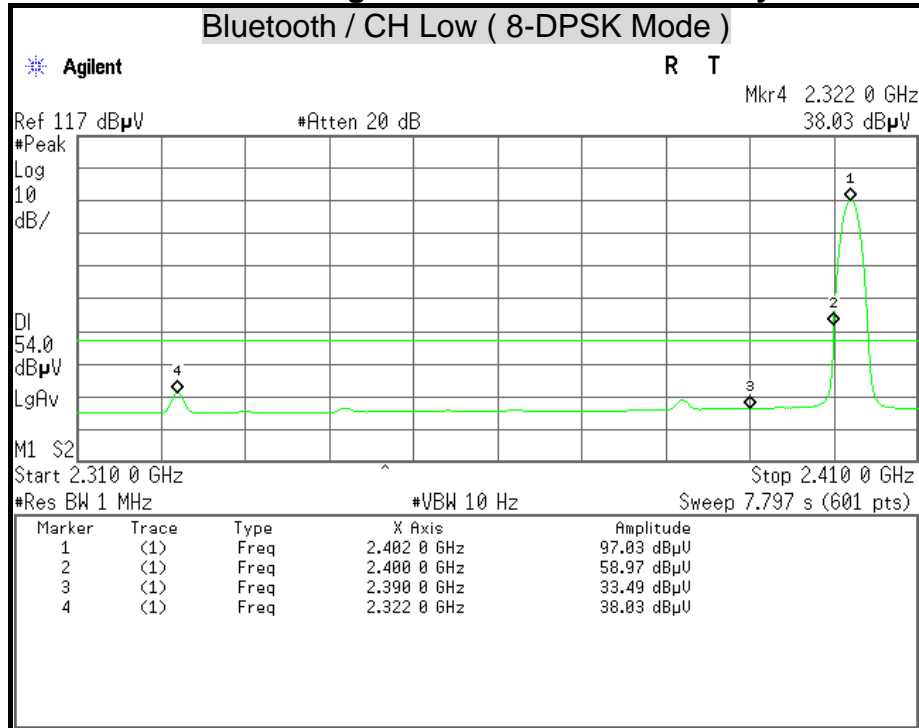



Detector Mode : Peak

Polarity : Horizontal

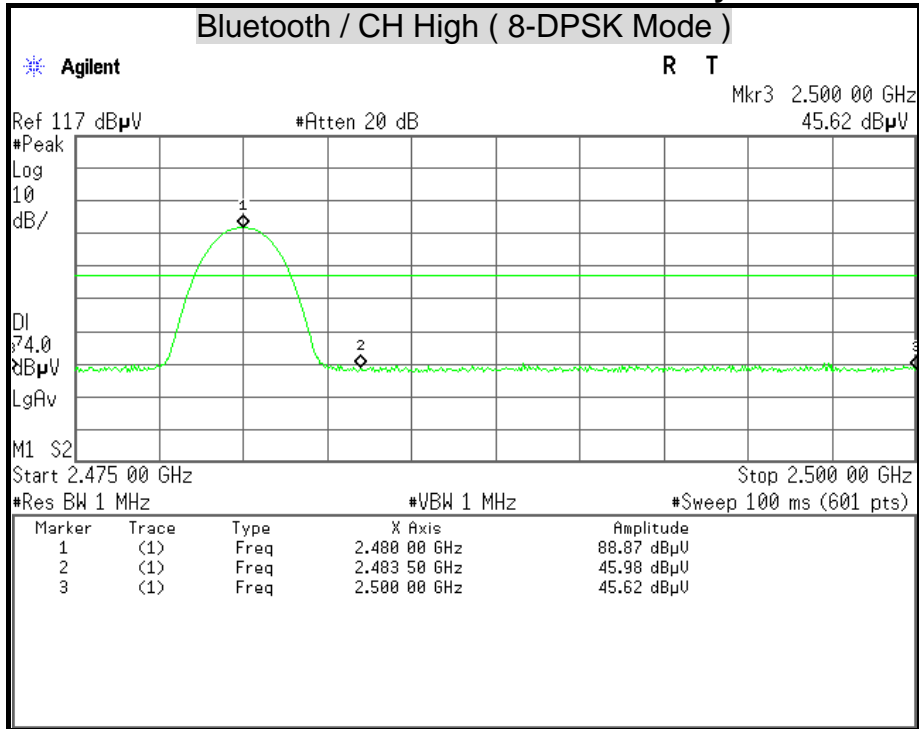

Detector Mode : Average

Polarity : Horizontal

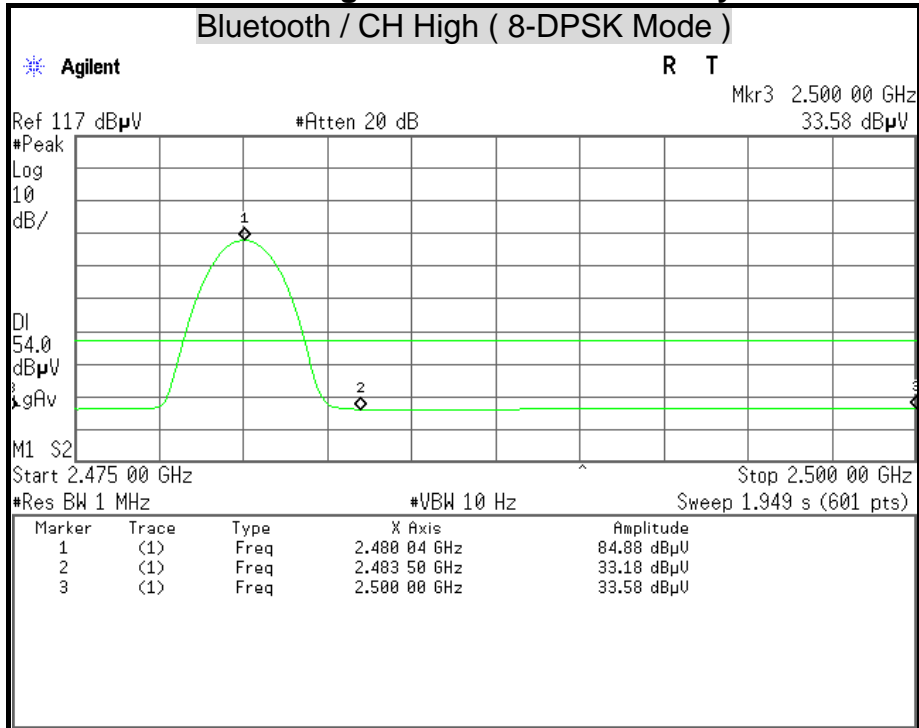



Detector Mode : Peak

Polarity : Vertical

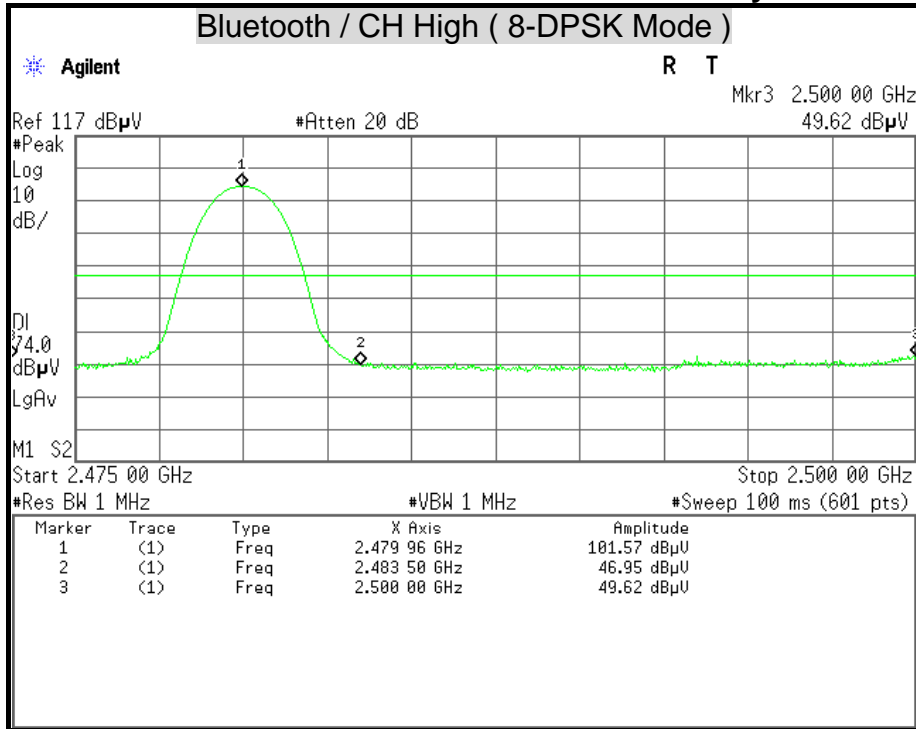

Detector Mode : Average

Polarity : Vertical

