



**FCC CFR47 PART 15 SUBPART E  
INDUSTRY CANADA RSS-210 ISSUE 7**

**CERTIFICATION TEST REPORT**

**FOR**

**802.11agn WLAN + BLUETOOTH PCI-E MINICARD**

**MODEL NUMBER: BCM943224PCIEBT2**

**FCC ID: QDS-BRCM1052  
IC: 4324A-BRCM1052**

**REPORT NUMBER: 10U13263-2, Revision B**

**ISSUE DATE: SEPTEMBER 01, 2010**

*Prepared for*

**BROADCOM CORPORATION  
190 MATHILDA PLACE  
SUNNYVALE, CA 94086, U.S.A.**

*Prepared by*

**COMPLIANCE CERTIFICATION SERVICES  
47173 BENICIA STREET  
FREMONT, CA 94538, U.S.A.  
TEL: (510) 771-1000  
FAX: (510) 661-0888**



**NVLAP LAB CODE 200065-0**

Revision History

<u>Rev.</u>	<u>Issue Date</u>	<u>Revisions</u>	<u>Revised By</u>
--	08/19/10	Initial Issue	T. Chan
A	08/20/10	Corrected Typos	T. Chan
B	09/01/10	Increased output power HT40 SISO Channel 38 to 15dBm	T. Chan

## TABLE OF CONTENTS

<b>1. ATTESTATION OF TEST RESULTS</b> .....	<b>7</b>
<b>2. TEST METHODOLOGY</b> .....	<b>8</b>
<b>3. FACILITIES AND ACCREDITATION</b> .....	<b>8</b>
<b>4. CALIBRATION AND UNCERTAINTY</b> .....	<b>8</b>
4.1. MEASURING INSTRUMENT CALIBRATION.....	8
4.2. SAMPLE CALCULATION.....	8
4.3. MEASUREMENT UNCERTAINTY.....	8
<b>5. EQUIPMENT UNDER TEST</b> .....	<b>9</b>
5.1. DESCRIPTION OF EUT.....	9
5.2. MAXIMUM OUTPUT POWER.....	9
5.3. SOFTWARE AND FIRMWARE.....	10
5.4. WORST-CASE CONFIGURATION AND MODE .....	10
5.5. DESCRIPTION OF AVAILABLE ANTENNAS.....	11
5.6. DESCRIPTION OF TEST SETUP.....	11
<b>6. TEST AND MEASUREMENT EQUIPMENT</b> .....	<b>13</b>
<b>7. ANTENNA PORT TEST RESULTS</b> .....	<b>14</b>
7.1. 802.11a MODE IN THE 5.2 GHz BAND.....	14
7.1.1. 26 dB and 99% BANDWIDTH .....	14
7.1.2. OUTPUT POWER .....	17
7.1.3. PEAK POWER SPECTRAL DENSITY.....	20
7.1.4. PEAK EXCURSION .....	23
7.1.5. CONDUCTED SPURIOUS EMISSIONS.....	26
7.2. 802.11n HT20 MODE IN THE 5.2 GHz BAND.....	30
<b>HT20 MCS8 SDM – Non-Coherent</b> .....	<b>30</b>
7.2.1. 26 dB and 99% BANDWIDTH .....	30
7.2.2. OUTPUT POWER .....	33
7.2.3. PEAK POWER SPECTRAL DENSITY.....	37
7.2.4. PEAK EXCURSION .....	39
7.2.5. CONDUCTED SPURIOUS EMISSIONS.....	42
<b>HT20 MCS12 SDM – Non-Coherent</b> .....	<b>45</b>
7.2.6. 26 dB and 99% BANDWIDTH .....	45
7.2.7. OUTPUT POWER .....	48
7.2.8. PEAK POWER SPECTRAL DENSITY.....	52
7.2.9. PEAK EXCURSION .....	54
7.2.10. CONDUCTED SPURIOUS EMISSIONS.....	57

**HT20 MCS15 SDM – Non-Coherent ..... 60**

- 7.2.11. 26 dB and 99% BANDWIDTH ..... 60
- 7.2.12. OUTPUT POWER ..... 63
- 7.2.13. PEAK POWER SPECTRAL DENSITY ..... 67
- 7.2.14. PEAK EXCURSION ..... 69
- 7.2.15. CONDUCTED SPURIOUS EMISSIONS ..... 72

7.3. 802.11n HT40 SISO MODE IN THE 5.2 GHz BAND ..... 75

- 7.3.1. 26 dB and 99% BANDWIDTH ..... 75
- 7.3.2. OUTPUT POWER ..... 77
- 7.3.3. PEAK POWER SPECTRAL DENSITY ..... 79
- 7.3.4. PEAK EXCURSION ..... 81
- 7.3.5. CONDUCTED SPURIOUS EMISSIONS ..... 83

7.4. 802.11n HT40 MODE IN THE 5.2 GHz BAND ..... 86

**HT40 MCS8 SDM – Non-Coherent ..... 86**

- 7.4.1. 26 dB and 99% BANDWIDTH ..... 86
- 7.4.2. OUTPUT POWER ..... 89
- 7.4.3. PEAK POWER SPECTRAL DENSITY ..... 92
- 7.4.4. PEAK EXCURSION ..... 94
- 7.4.5. CONDUCTED SPURIOUS EMISSIONS ..... 97

**HT40 MCS12 SDM – Non-Coherent ..... 100**

- 7.4.6. 26 dB and 99% BANDWIDTH ..... 100
- 7.4.7. OUTPUT POWER ..... 103
- 7.4.8. PEAK POWER SPECTRAL DENSITY ..... 106
- 7.4.9. PEAK EXCURSION ..... 108
- 7.4.10. CONDUCTED SPURIOUS EMISSIONS ..... 111

7.5. 802.11a MODE IN THE 5.3 GHz BAND ..... 114

- 7.5.1. 26 dB and 99% BANDWIDTH ..... 114
- 7.5.2. OUTPUT POWER ..... 117
- 7.5.3. PEAK POWER SPECTRAL DENSITY ..... 120
- 7.5.4. PEAK EXCURSION ..... 123
- 7.5.5. CONDUCTED SPURIOUS EMISSIONS ..... 126

7.6. 802.11n HT20 MODE IN THE 5.3 GHz BAND ..... 130

- 7.6.1. 26 dB and 99% BANDWIDTH ..... 130
- 7.6.2. OUTPUT POWER ..... 134
- 7.6.3. PEAK POWER SPECTRAL DENSITY ..... 139
- 7.6.4. PEAK EXCURSION ..... 142
- 7.6.5. CONDUCTED SPURIOUS EMISSIONS ..... 146

7.7. 802.11n HT40 SISO MODE IN THE 5.3 GHz BAND ..... 150

- 7.7.1. 26 dB and 99% BANDWIDTH ..... 150
- 7.7.2. OUTPUT POWER ..... 152
- 7.7.3. PEAK POWER SPECTRAL DENSITY ..... 154
- 7.7.4. PEAK EXCURSION ..... 156
- 7.7.5. CONDUCTED SPURIOUS EMISSIONS ..... 158

7.8. 802.11n HT40 MODE IN THE 5.3 GHz BAND ..... 160

- 7.8.1. 26 dB and 99% BANDWIDTH ..... 160
- 7.8.2. OUTPUT POWER ..... 163

7.8.3.	PEAK POWER SPECTRAL DENSITY .....	166
7.8.4.	PEAK EXCURSION .....	168
7.8.5.	CONDUCTED SPURIOUS EMISSIONS.....	171
7.9.	<b>802.11a MODE IN THE 5.6 GHz BAND.....</b>	<b>173</b>
7.9.1.	26 dB and 99% BANDWIDTH .....	173
7.9.2.	OUTPUT POWER .....	176
7.9.3.	PEAK POWER SPECTRAL DENSITY .....	179
7.9.4.	PEAK EXCURSION .....	182
7.9.5.	CONDUCTED SPURIOUS EMISSIONS.....	185
7.10.	<b>802.11n HT20 MODE IN THE 5.6 GHz BAND.....</b>	<b>189</b>
7.10.1.	26 dB and 99% BANDWIDTH .....	189
7.10.2.	OUTPUT POWER .....	193
7.10.3.	PEAK POWER SPECTRAL DENSITY .....	197
7.10.4.	PEAK EXCURSION .....	200
7.10.5.	CONDUCTED SPURIOUS EMISSIONS.....	204
7.11.	<b>802.11n HT40 SISO MODE IN THE 5.6 GHz BAND .....</b>	<b>208</b>
7.11.1.	26 dB and 99% BANDWIDTH .....	208
7.11.2.	OUTPUT POWER .....	211
7.11.3.	PEAK POWER SPECTRAL DENSITY .....	214
7.11.4.	PEAK EXCURSION .....	217
7.11.5.	CONDUCTED SPURIOUS EMISSIONS.....	220
7.12.	<b>802.11n HT40 MODE IN THE 5.6 GHz BAND.....</b>	<b>223</b>
7.12.1.	26 dB and 99% BANDWIDTH .....	223
7.12.2.	OUTPUT POWER .....	227
7.12.3.	PEAK POWER SPECTRAL DENSITY .....	231
7.12.4.	PEAK EXCURSION .....	234
7.12.5.	CONDUCTED SPURIOUS EMISSIONS.....	238
7.12.6.	CO-LOCATED CONDUCTED SPURIOUS EMISSIONS .....	241
<b>8.</b>	<b>RADIATED TEST RESULTS .....</b>	<b>244</b>
8.1.	<i>LIMITS AND PROCEDURE .....</i>	<i>244</i>
8.2.	<i>TRANSMITTER ABOVE 1 GHz.....</i>	<i>245</i>
8.2.1.	802.11a MODE IN THE LOWER 5.2 GHz BAND.....	245
8.2.2.	802.11n HT20 MODE IN THE LOWER 5.2 GHz BAND.....	248
	<b><i>HT20 MCS8 SDM – Non-Coherent .....</i></b>	<b><i>248</i></b>
	<b><i>HT20 MCS12 SDM – Non-Coherent .....</i></b>	<b><i>251</i></b>
	<b><i>HT20 MCS15 SDM – Non-Coherent .....</i></b>	<b><i>254</i></b>
8.2.3.	802.11n HT40 SISO MODE IN THE LOWER 5.2 GHz BAND .....	257
8.2.4.	802.11n HT40 MIMO MODE IN THE LOWER 5.2 GHz BAND .....	260
	<b><i>HT40 MCS8 SDM –Non - Coherent .....</i></b>	<b><i>260</i></b>
	<b><i>HT40 MCS12 SDM –Non - Coherent .....</i></b>	<b><i>263</i></b>
8.2.5.	802.11a MODE IN THE UPPER 5.3 GHz BAND .....	266
8.2.6.	802.11n HT20 MODE IN THE UPPER 5.3 GHz BAND.....	269

8.2.7. 802.11n HT40 SISO MODE IN THE UPPER 5.3 GHz BAND ..... 272  
8.2.8. 802.11n HT40 MIMO MCS0 MODE IN THE UPPER 5.3 GHz BAND ..... 275  
8.2.9. 802.11a MODE IN THE 5.6 GHz BAND ..... 278  
8.2.10. 802.11n HT20 MODE IN THE 5.6 GHz BAND ..... 282  
8.2.11. 802.11n HT40 SISO MODE IN THE 5.6 GHz BAND ..... 286  
8.2.12. 802.11n HT40 MIMO MCS0 MODE IN THE 5.6 GHz BAND ..... 290  
8.3. RECEIVER ABOVE 1 GHz ..... 294  
8.3.1. FOR 20 MHz BANDWIDTH IN THE 5 GHz BAND ..... 294  
8.3.2. FOR 40 MHz BANDWIDTH IN THE 5 GHz BAND ..... 295  
8.4. WORST-CASE BELOW 1 GHz ..... 296  
**9. AC POWER LINE CONDUCTED EMISSIONS ..... 297**  
**10. DYNAMIC FREQUENCY SELECTION ..... 301**  
10.1. OVERVIEW ..... 301  
10.1.1. LIMITS ..... 301  
10.1.2. TEST AND MEASUREMENT SYSTEM ..... 304  
10.1.3. SETUP OF EUT ..... 306  
10.1.4. DESCRIPTION OF EUT ..... 307  
10.2. RESULTS FOR 20 MHz BANDWIDTH ..... 308  
10.2.1. TEST CHANNEL ..... 308  
10.2.2. RADAR WAVEFORM AND TRAFFIC ..... 308  
10.2.3. OVERLAPPING CHANNEL TESTS ..... 310  
10.2.4. MOVE AND CLOSING TIME ..... 310  
10.3. RESULTS FOR 40 MHz BANDWIDTH ..... 315  
10.3.1. TEST CHANNEL ..... 315  
10.3.2. RADAR WAVEFORM AND TRAFFIC ..... 315  
10.3.3. OVERLAPPING CHANNEL TESTS ..... 317  
10.3.4. MOVE AND CLOSING TIME ..... 317  
10.3.5. NON-OCCUPANCY PERIOD ..... 322  
**11. MAXIMUM PERMISSIBLE EXPOSURE ..... 323**  
**12. SETUP PHOTOS ..... 326**

# 1. ATTESTATION OF TEST RESULTS

**COMPANY NAME:** BROADCOM CORPORATION  
190 MATHILDA PLACE  
SUNNYVALE, CA 94086, USA

**EUT DESCRIPTION:** 802.11agn WLAN + Bluetooth PCI-E Minicard

**MODEL:** BCM943224PCIEBT2

**SERIAL NUMBER:** 489

**DATE TESTED:** JUNE 23 – SEPTEMBER 01, 2010

APPLICABLE STANDARDS	
STANDARD	TEST RESULTS
CFR 47 Part 15 Subpart E	Pass
INDUSTRY CANADA RSS-210 Issue 7 Annex 9	Pass
INDUSTRY CANADA RSS-GEN Issue 2	Pass

Compliance Certification Services, Inc. (CCS) tested the above equipment in accordance with the requirements set forth in the above standards. All indications of Pass/Fail in this report are opinions expressed by CCS based on interpretations and/or observations of test results. Measurement Uncertainties were not taken into account and are published for informational purposes only. The test results show that the equipment tested is capable of demonstrating compliance with the requirements as documented in this report.

**Note:** The results documented in this report apply only to the tested sample, under the conditions and modes of operation as described herein. This document may not be altered or revised in any way unless done so by CCS and all revisions are duly noted in the revisions section. Any alteration of this document not carried out by CCS will constitute fraud and shall nullify the document. This report must not be used by the client to claim product certification, approval, or endorsement by NVLAP, NIST, any agency of the Federal Government, or any agency of any government.

Approved & Released For CCS By:

Tested By:



THU CHAN  
ENGINEERING MANAGER  
COMPLIANCE CERTIFICATION SERVICES

VIEN TRAN  
EMC ENGINEER  
COMPLIANCE CERTIFICATION SERVICES

## 2. TEST METHODOLOGY

The tests documented in this report were performed in accordance with ANSI C63.4-2003, FCC CFR 47 Part 2, FCC CFR 47 Part 15, FCC 06-96, RSS-GEN Issue 2, and RSS-210 Issue 7.

## 3. FACILITIES AND ACCREDITATION

The test sites and measurement facilities used to collect data are located at 47173 Benicia Street, Fremont, California, USA.

CCS is accredited by NVLAP, Laboratory Code 200065-0. The full scope of accreditation can be viewed at <http://www.ccsemc.com>.

## 4. CALIBRATION AND UNCERTAINTY

### 4.1. MEASURING INSTRUMENT CALIBRATION

The measuring equipment utilized to perform the tests documented in this report has been calibrated in accordance with the manufacturer's recommendations, and is traceable to recognized national standards.

### 4.2. SAMPLE CALCULATION

Where relevant, the following sample calculation is provided:

$$\begin{aligned} \text{Field Strength (dBuV/m)} &= \text{Measured Voltage (dBuV)} + \text{Antenna Factor (dB/m)} + \\ &\text{Cable Loss (dB)} - \text{Preamp Gain (dB)} \\ 36.5 \text{ dBuV} + 18.7 \text{ dB/m} + 0.6 \text{ dB} - 26.9 \text{ dB} &= 28.9 \text{ dBuV/m} \end{aligned}$$

### 4.3. MEASUREMENT UNCERTAINTY

Where relevant, the following measurement uncertainty levels have been estimated for tests performed on the apparatus:

PARAMETER	UNCERTAINTY
Conducted Disturbance, 0.15 to 30 MHz	3.52 dB
Radiated Disturbance, 30 to 1000 MHz	4.94 dB

Uncertainty figures are valid to a confidence level of 95%.



## 5. EQUIPMENT UNDER TEST

### 5.1. DESCRIPTION OF EUT

The EUT is an 802.11agn WLAN + Bluetooth PCI-E Minicard.  
 The radio module is manufactured by Broadcom.

### 5.2. MAXIMUM OUTPUT POWER

The transmitter has a maximum conducted output power as follows:

#### 5150 to 5250 MHz Authorized Band

Frequency Range (MHz)	Mode	Peak Power Chain 0 (dBm)	Peak Power Chain 1 (dBm)	Total Peak Power (dBm)	Output Power (mW)
5180 - 5240	802.11a Legacy			13.25	21.13
5180 - 5240	802.11n 20MHz SISO	Covered by the worst case 802.11a Legacy testing			
5180 - 5240	802.11n 20MHz CDD	Not applicable for this mode			
5180 - 5240	802.11n 20MHz MCS8 SDM	10.16	9.91	13.05	20.17
5180 - 5240	802.11n 20MHz MCS12 SDM	9.02	10.06	12.58	18.12
5180 - 5240	802.11n 20MHz MCS15 SDM	10.17	9.36	12.79	19.03
5190 - 5230	802.11n 40MHz SISO			16.20	41.69
5190 - 5230	802.11n 40MHz CDD	Not applicable for this mode			
5190 - 5230	802.11n 40MHz MCS8 SDM	12.14	12.08	15.12	32.51
5190 - 5230	802.11n 40MHz MCS12 SDM	11.08	12.55	14.89	30.81

#### 5250 - 5350 MHz Authorized Band

Frequency Range (MHz)	Mode	Peak Power Chain 0 (dBm)	Peak Power Chain 1 (dBm)	Total Peak Power (dBm)	Output Power (mW)
5260 - 5320	802.11a Legacy			17.70	58.88
5260 - 5320	802.11n 20MHz SISO	Covered by the worst case 802.11a Legacy testing			
5260 - 5320	802.11a CDD Mode	Covered by the worst case 802.11n 20 MHz CDD			
5260 - 5320	802.11n 20MHz CDD	13.35	13.07	16.22	41.90
5270 - 5310	802.11n 40MHz SISO			16.84	48.31
5270 - 5310	802.11n 40MHz CDD	15.69	15.76	18.74	74.74

#### 5470 - 5725 MHz Authorized Band

Frequency Range (MHz)	Mode	Peak Power Chain 0 (dBm)	Peak Power Chain 1 (dBm)	Total Peak Power (dBm)	Output Power (mW)
5500 - 5700	802.11a Legacy			17.37	54.58
5500 - 5700	802.11n 20MHz SISO	Covered by the worst case 802.11a Legacy testing			
5500 - 5700	802.11a CDD Mode	Covered by the worst case 802.11n 20 MHz CDD			
5500 - 5700	802.11n 20MHz CDD	13.48	11.93	15.78	37.88
5510 - 5670	802.11n 40MHz SISO			18.16	65.46
5510 - 5670	802.11n 40MHz CDD	16.64	17.25	19.97	99.22

### **5.3. SOFTWARE AND FIRMWARE**

The EUT driver software installed during testing was Broadcom, rev. 5.10.131.31  
The test utility software used during testing was BCM Internal, rev. 5.10.RC131.31

### **5.4. WORST-CASE CONFIGURATION AND MODE**

The EUT was tested as an external module installed in a test jig board connected to a host Laptop PC.

Worst-Case data rates were utilized from preliminary testing of the Chipset, worst-case data rates used during the testing are as follows:

All final tests in the 802.11a Mode (Legacy) were made at 6 Mb/s.

All final tests in the 802.11n Mode (20 MHz CDD/SDM) were made at MCS0, MCS8, MCS12 & MCS15.

All final tests in the 802.11n Mode (40 MHz SISO) were made at MCS0

All final tests in the 802.11n Mode (40 MHz CDD/SDM) were made at MCS0, MCS8, & MCS12.

Worst-case mode and channel used for 30-1000 MHz radiated and power line conducted emissions was the mode and channel with the highest output power, that was determined to be 11n HT20 mode, mid channel..

For MIMO conducted spurious measurement preliminary testing showed that combiner is worst-case compared to individual chains; therefore final measurements were performed using combiner for all channels and modes.

For MIMO PSD measurement preliminary testing showed that combiner is worst-case compared to individual chains; therefore final measurements were performed using combiner for all channels and modes.

All legacy/SISO modes were measured with the highest gain for each type of antenna.

All MIMO modes were measured with the highest combination of gains for each type of antenna. Note that this combination of antennas will not be implemented in the end product. This combination was selected for testing purposes only, to accommodate the highest gain of each antenna type in one single test configuration. The combined gain of this test configuration is higher than any combined gain that will be implemented in the end product.

For the collocation between Bluetooth 2.4GHz and WLAN 5GHz bands, no inter-modulated or interfered emissions should be involved due to both frequency bands separated more than 2GHz range, so no test was required.

## 5.5. DESCRIPTION OF AVAILABLE ANTENNAS

The radio utilizes with two different types of antenna, with the maximum gain as table below:

	System 16 WiFi 1 (Main) Short Cable	System 16 WiFi 2 (Aux.) Long Cable			System 99 WiFi 1 (Main) Short Cable	System 99 WiFi 2 (Aux.) Long Cable	
GHz	Horizontal	Horizontal	combined log	GHz	Horizontal	Horizontal	combined log
2.4	1.67	5.98	7.35	2.4	4.97	4.87	7.93
5.2	5.93	5.75	8.85	5.5	5.77	6.61	9.22
5.3	6.12	5.57	8.86	5.8	4.90	6.28	8.65

Minimum gain:

	System 16 WiFi 1 (Main) Short Cable	System 16 WiFi 2 (Aux.) Long Cable			System 99 WiFi 1 (Main) Short Cable	System 99 WiFi 2 (Aux.) Long Cable	
GHz	Vertical	Vertical	combined log	GHz	Vertical	Vertical	combined log
2.4	-0.1	3.74	5.24	5.2	1.13	2.22	4.72
5.5	2.68	1.79	5.27	5.3	1.77	3.20	5.55
5.8	2.12	1.05	4.63				

## 5.6. DESCRIPTION OF TEST SETUP

### SUPPORT EQUIPMENT

PERIPHERAL SUPPORT EQUIPMENT LIST				
Description	Manufacturer	Model	Serial Number	FCC ID
Laptop PC	Dell	Inspiron 1526	N/A	DoC
AC Adapter	Dell	DA90PS1-00	CN-0MM545-48661-78J-9M4Q	N/A

### I/O CABLES

I/O CABLE LIST						
Cable No.	Port	# of Identical Ports	Connector Type	Cable Type	Cable Length	Remarks
1	AC	1	AC	Unshielded	1.8 m	N/A
2	DC	1	DC	Unshielded	1.8 m	Ferrite on laptop's end

### TEST SETUP

The EUT is connected to a host laptop computer via Express card to MiniPCI-E adapter board during the test. Test software exercised the radio card.

**SETUP DIAGRAM**

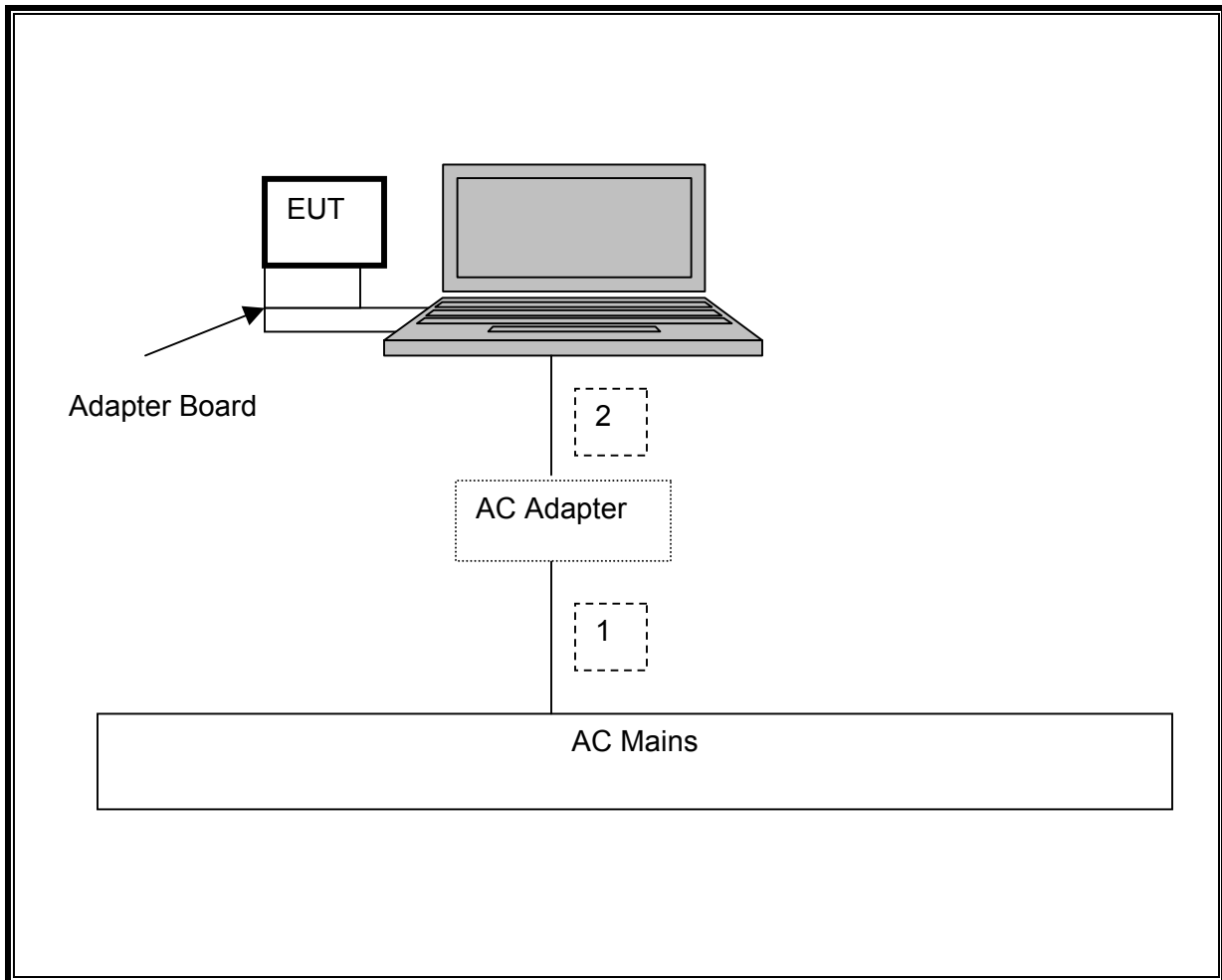

## 6. TEST AND MEASUREMENT EQUIPMENT

The following test and measurement equipment was utilized for the tests documented in this report:

TEST EQUIPMENT LIST				
Description	Manufacturer	Model	Asset	Cal Due
Spectrum Analyzer, 44 GHz	Agilent / HP	E4446A	C00996	10/29/11
Spectrum Analyzer, 26.5 GHz	Agilent / HP	E4440A	C01176	08/24/11
Antenna, Bilog, 2 GHz	Sunol Sciences	JB1	C01171	07/14/11
Antenna, Horn, 18 GHz	EMCO	3115	C00872	07/29/11
Antenna, Horn, 26.5 GHz	ARA	MWH-1826/B	C00980	07/29/11
Antenna, Horn, 40 GHz	ARA	MWH-2640/B	C00981	06/08/11
Preamplifier, 1300 MHz	Agilent / HP	8447D	C00778	07/06/11
Preamplifier, 26.5 GHz	Agilent / HP	8449B	C00749	08/04/11
Preamplifier, 40 GHz	Miteq	NSP4000-SP2	C00990	08/03/11
Peak Power Meter	Boonton	4541	C01186	03/01/11
Peak Power Sensor	Boonton	57318	0	02/24/11
Peak Power Meter	Agilent / HP	E4416A	C00963	12/04/11
Peak / Average Power Sensor	Agilent / HP	E9327A	C00964	12/04/11
EMI Test Receiver, 30 MHz	R & S	ESHS 20	N02396	05/06/11
LISN, 30 MHz	FCC	LISN-50/250-25-2	N02625	11/06/10
Highpass Filter, 7.6 GHz	Micro-Tronics	HPM13195	N02601	CNR

## 7. ANTENNA PORT TEST RESULTS

### 7.1. 802.11a MODE IN THE 5.2 GHz BAND

#### 7.1.1. 26 dB and 99% BANDWIDTH

##### LIMITS

None; for reporting purposes only.

##### TEST PROCEDURE

The transmitter output is connected to the spectrum analyzer. The RBW is set to 1% to 3% of the measured bandwidth. The VBW is set to 3 times the RBW. The sweep time is coupled. The spectrum analyzer internal bandwidth function is utilized.

##### RESULTS

Channel	Frequency (MHz)	26 dB Bandwidth (MHz)	99% Bandwidth (MHz)
Low	5180	18.727	16.3397
Middle	5200	18.188	16.1941
High	5240	18.424	16.3161

**26 dB & 99%BANDWIDTH**

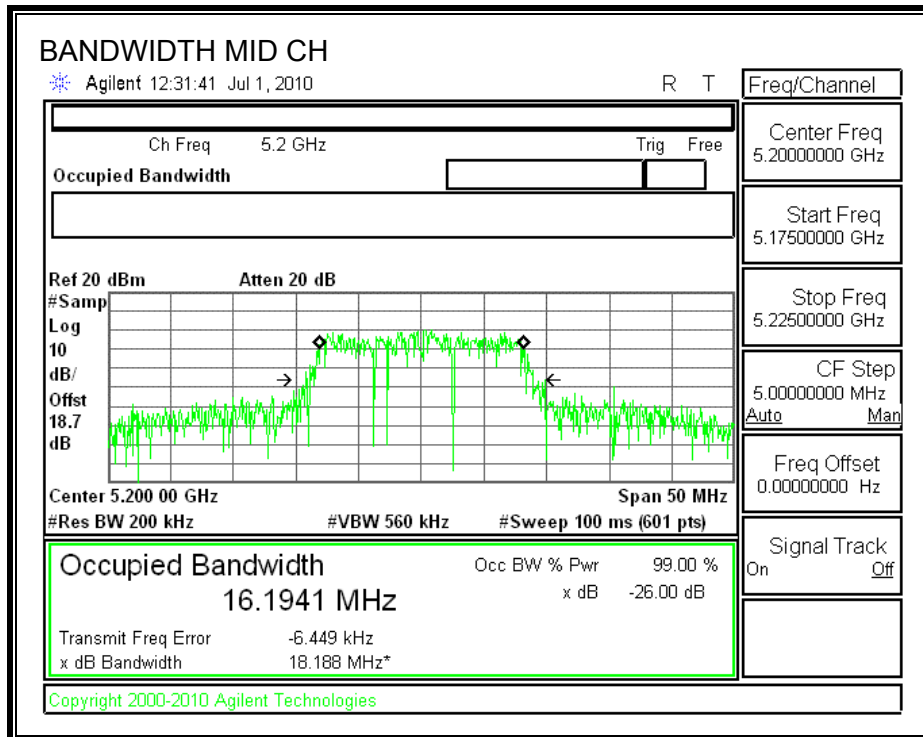
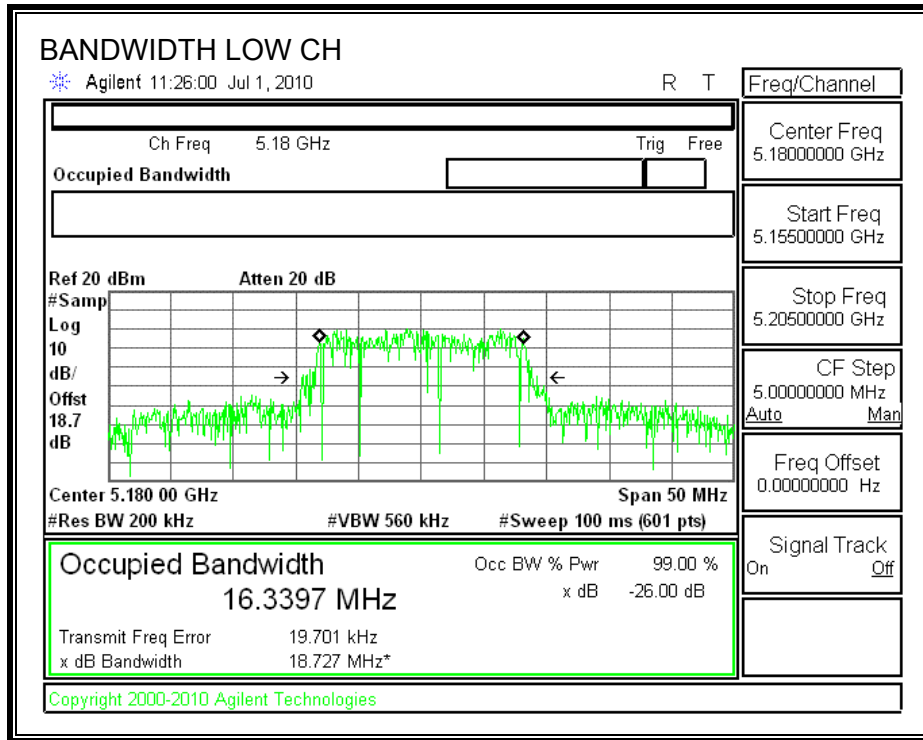

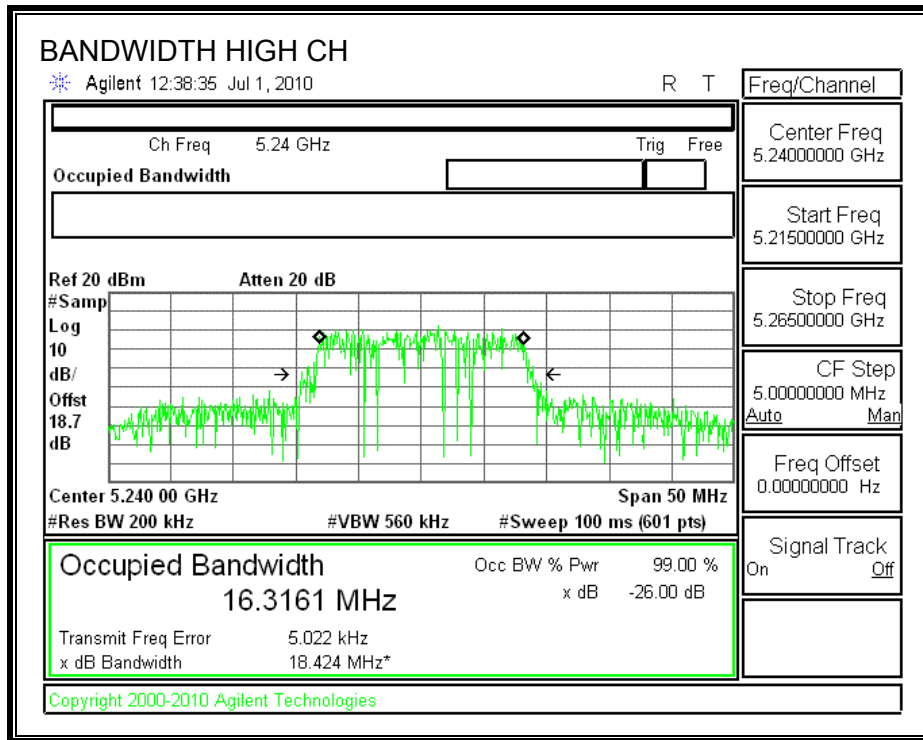



## 7.1.2. OUTPUT POWER

### LIMITS

FCC §15.407 (a) (1)

IC RSS-210 A9.2 (1)

For the 5.15-5.25 GHz band, the maximum conducted output power over the frequency band of operation shall not exceed the lesser of 50 mW or 4 dBm + 10 log B, where B is the 26-dB emission bandwidth in MHz. If transmitting antennas of directional gain greater than 6 dBi are used, both the peak transmit power and the peak power spectral density shall be reduced by the amount in dB that the directional gain of the antenna exceeds 6 dBi.

The maximum antenna gain is 5.93 dBi

### TEST PROCEDURE

The test is performed in accordance with FCC Public Notice: APPENDIX A Guidelines for Assessing Unlicensed National Information Infrastructure (U-NII) Devices – Part 15, Subpart E, August 2002.

The transmitter output operates continuously therefore Method # 1 is used.

### RESULTS

#### Limit

Channel	Frequency (MHz)	Fixed Limit (dBm)	B (MHz)	4 + 10 Log B Limit (dBm)	Antenna Gain (dBi)	Limit (dBm)
Low	5180	17	18.727	16.72	5.93	16.72
Mid	5200	17	18.188	16.60	5.93	16.60
High	5240	17	18.424	16.65	5.93	16.65

#### Results

Channel	Frequency (MHz)	Power (dBm)	Limit (dBm)	Margin (dB)
Low	5180	13.18	16.72	-3.54
Mid	5200	13.25	16.60	-3.35
High	5240	13.14	16.65	-3.51

**OUTPUT POWER**

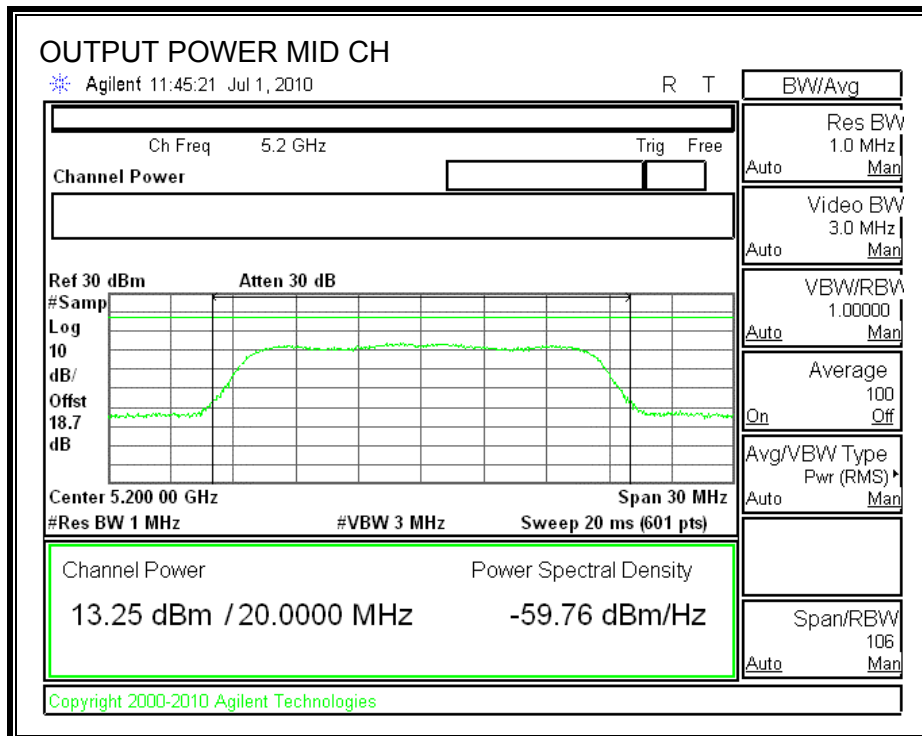
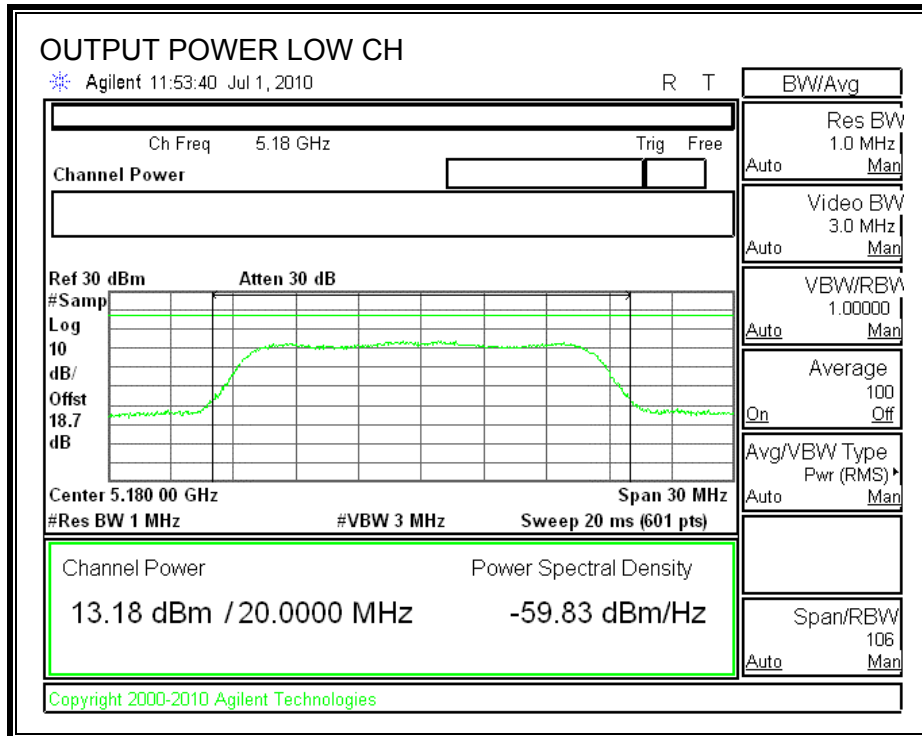

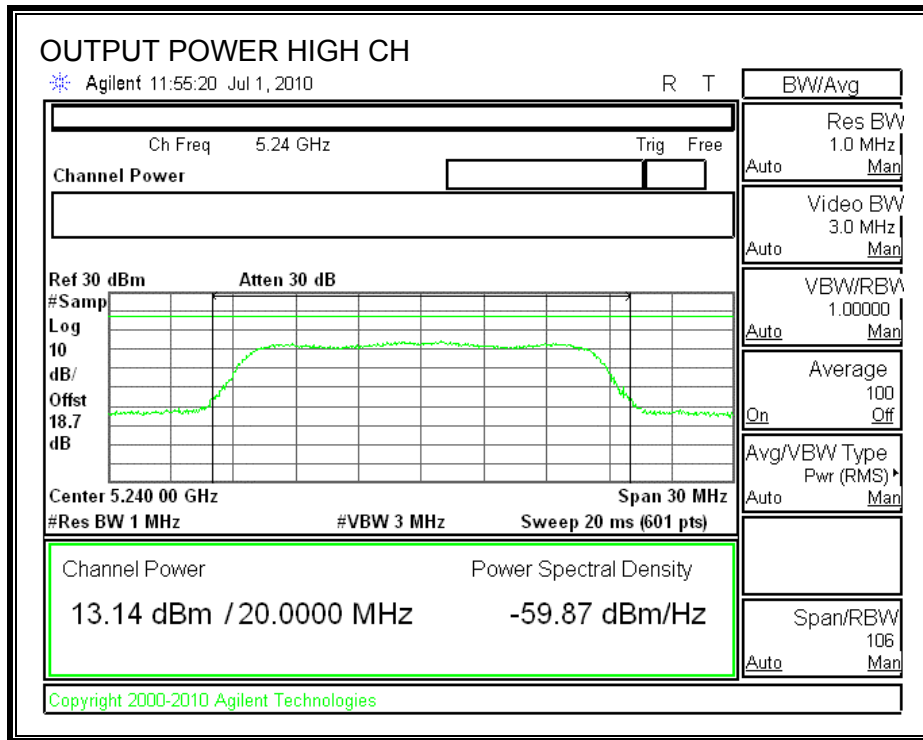

### 7.1.3. PEAK POWER SPECTRAL DENSITY

#### LIMITS

FCC §15.407 (a) (1)

IC RSS-210 A9.2 (1)

For the 5.15-5.25 GHz band, the peak power spectral density shall not exceed 4 dBm in any 1 MHz band. If transmitting antennas of directional gain greater than 6 dBi are used, both the peak transmit power and the peak power spectral density shall be reduced by the amount in dB that the directional gain of the antenna exceeds 6 dBi.

The maximum antenna gain is equal to 5.93 dBi, therefore the limit is 4 dBm.

#### TEST PROCEDURE

The test is performed in accordance with FCC Public Notice: APPENDIX A Guidelines for Assessing Unlicensed National Information Infrastructure (U-NII) Devices – Part 15, Subpart E, August 2002. PPSD method #2 was used.

#### RESULTS

Channel	Frequency (MHz)	PPSD (dBm)	Limit (dBm)	Margin (dB)
Low	5180	3.69	4.00	-0.31
Middle	5200	3.59	4.00	-0.41
High	5240	3.78	4.00	-0.22

**POWER SPECTRAL DENSITY**

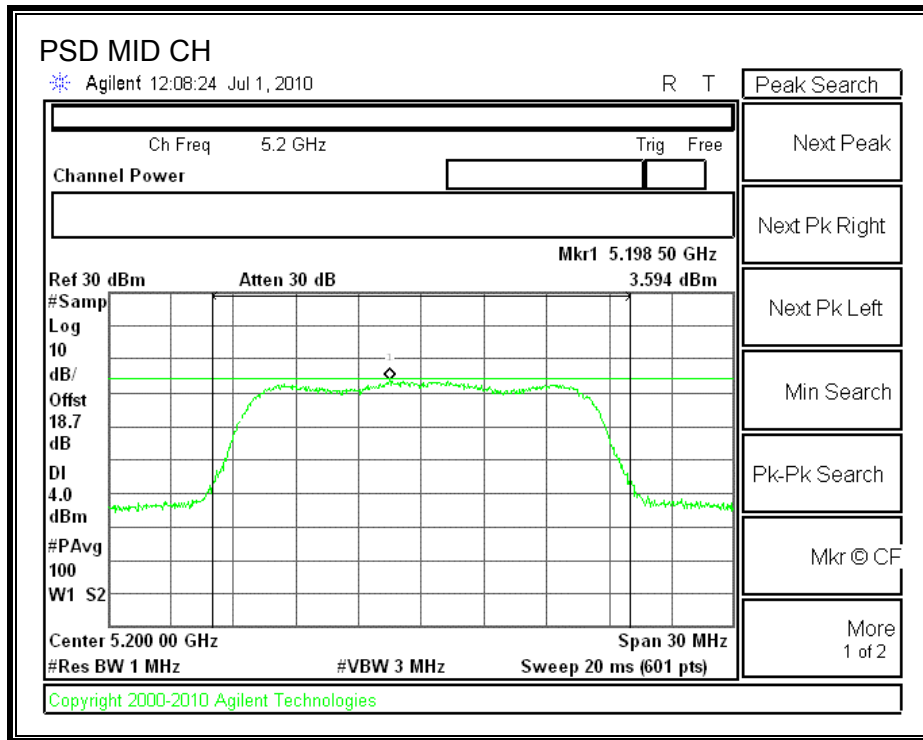
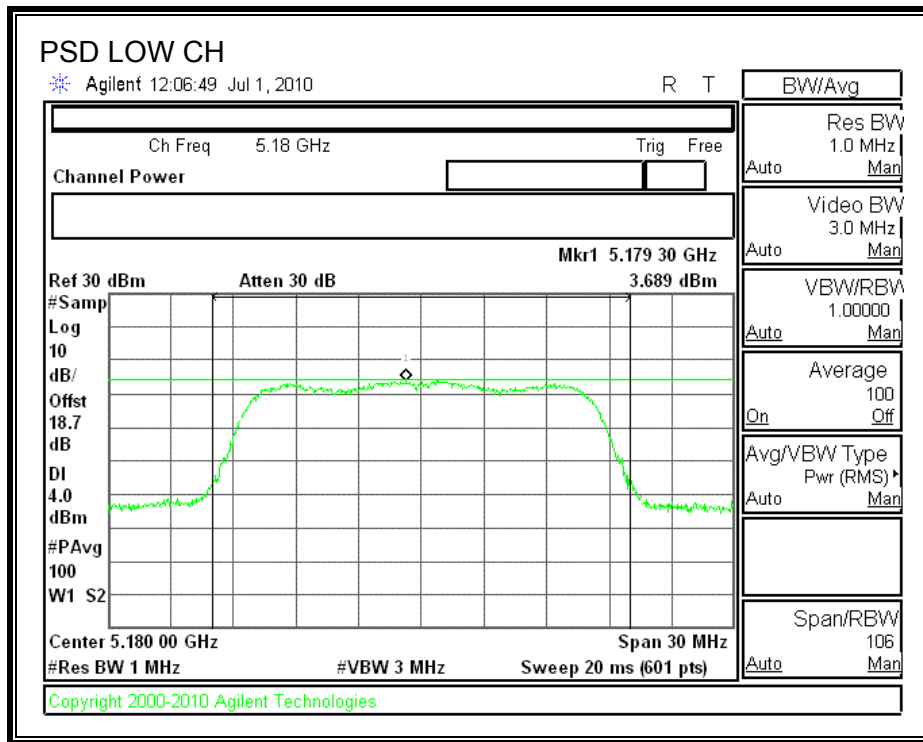

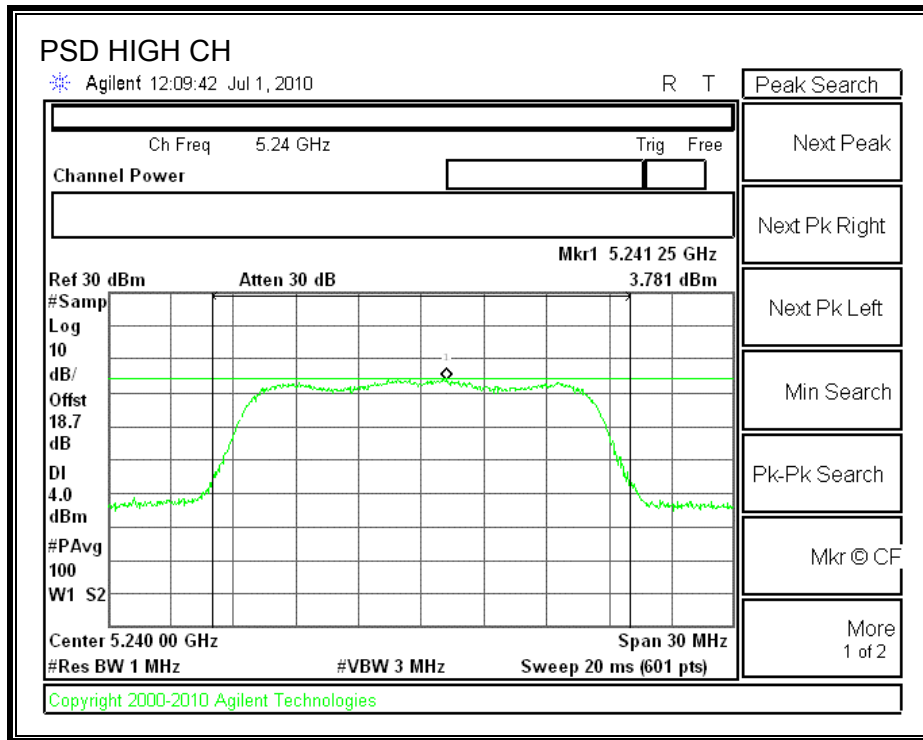

### 7.1.4. PEAK EXCURSION

#### LIMITS

FCC §15.407 (a) (6)

The ratio of the peak excursion of the modulation envelope (measured using a peak hold function) to the peak transmit power (measured as specified above) shall not exceed 13 dB across any 1 MHz bandwidth or the emission bandwidth whichever is less.

#### TEST PROCEDURE

The test is performed in accordance with FCC Public Notice: APPENDIX A Guidelines for Assessing Unlicensed National Information Infrastructure (U-NII) Devices – Part 15, Subpart E, August 2002.

Since Method # 1 was used for peak power measurements, Method # 1 settings are used for the second PPSD trace.

#### RESULTS

Channel	Frequency (MHz)	Peak Excursion (dB)	Limit (dB)	Margin (dB)
Low	5180	8.69	13	-4.31
Middle	5200	9.76	13	-3.24
High	5240	8.83	13	-4.17

**PEAK EXCURSION**

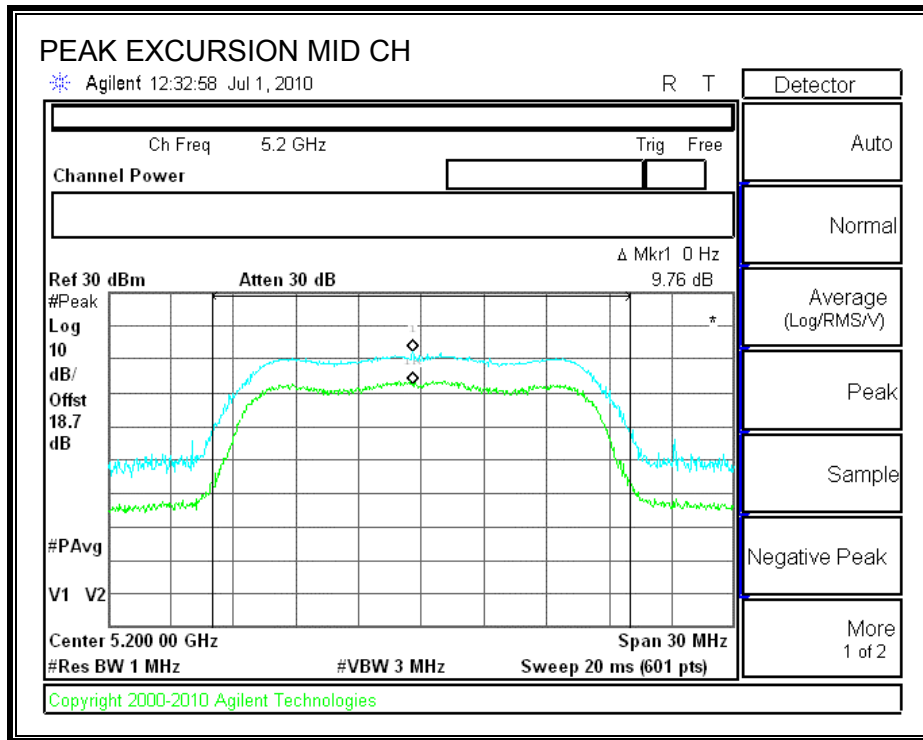
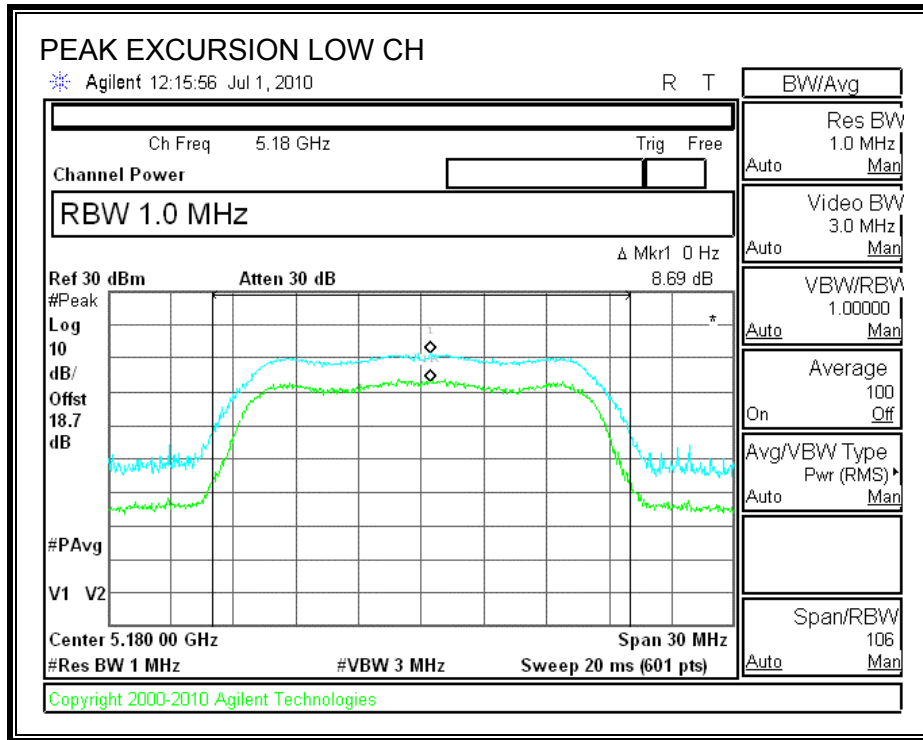



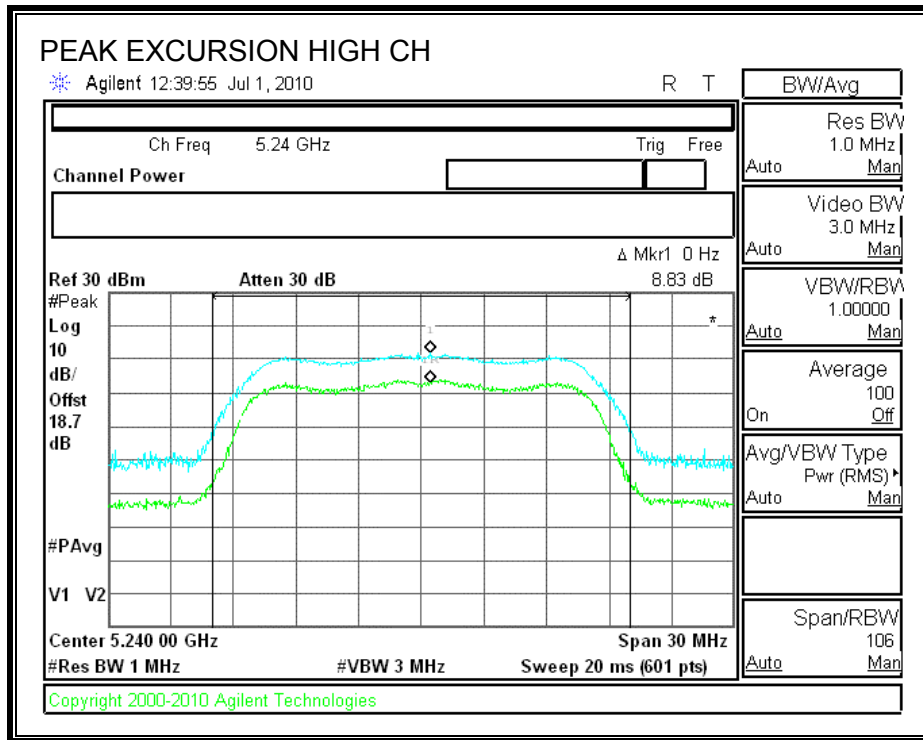

## 7.1.5. CONDUCTED SPURIOUS EMISSIONS

### LIMITS

FCC §15.407 (b) (1)

IC RSS-210 A9.3 (1)

For transmitters operating in the 5.15-5.25 GHz band: all emissions outside of the 5.15-5.35 GHz band shall not exceed an EIRP of -27 dBm / MHz.

### TEST PROCEDURE

Conducted RF measurements of the transmitter output are made to confirm that the EUT antenna port conducted emissions meet the specified limit and to identify any spurious signals that require further investigation or measurements on the radiated emissions site.

The transmitter output is connected to the spectrum analyzer. The resolution bandwidth is set to 1 MHz. The video bandwidth is set to 1MHz. Peak detection measurements are compared to EIRP limit, adjusted for the maximum antenna gain.

Measurements are made over the 30 MHz to 40 GHz range with the transmitter set to the lowest, middle, and highest channels.

**SPURIOUS EMISSIONS**

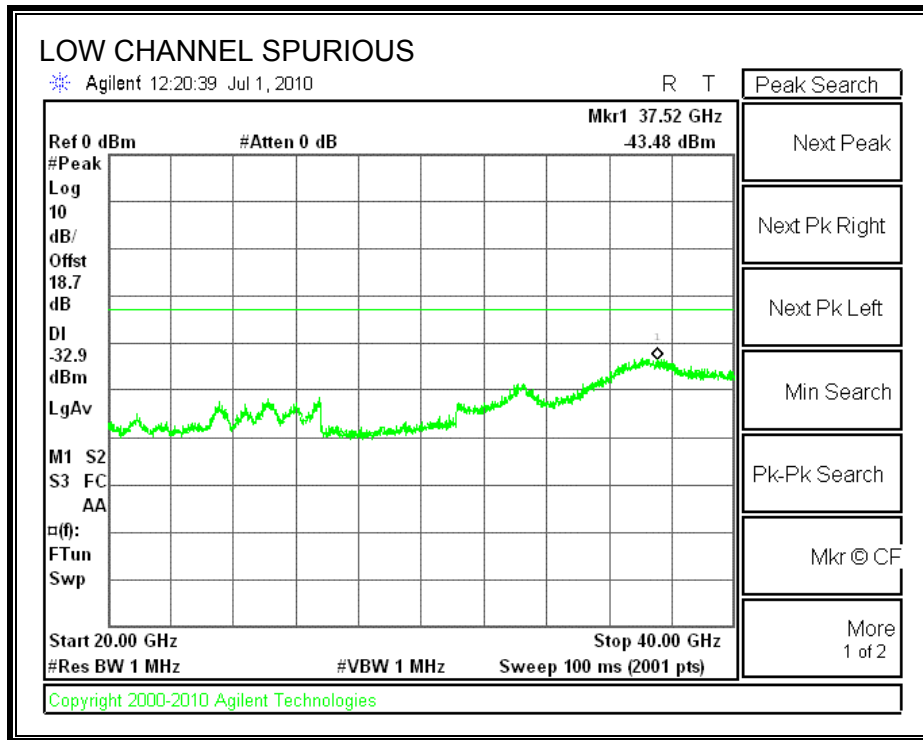
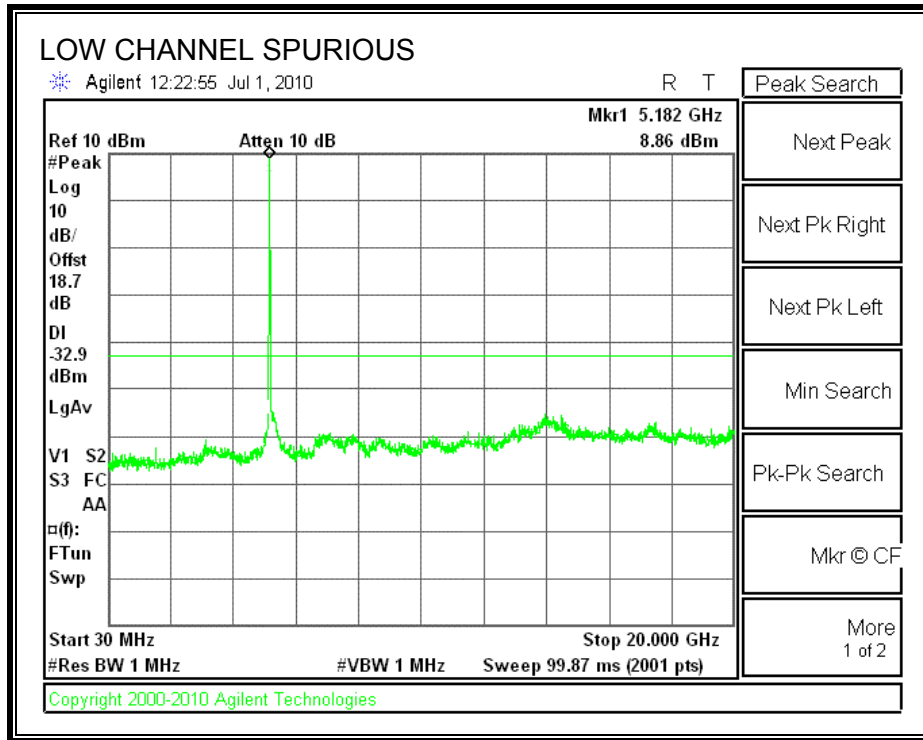

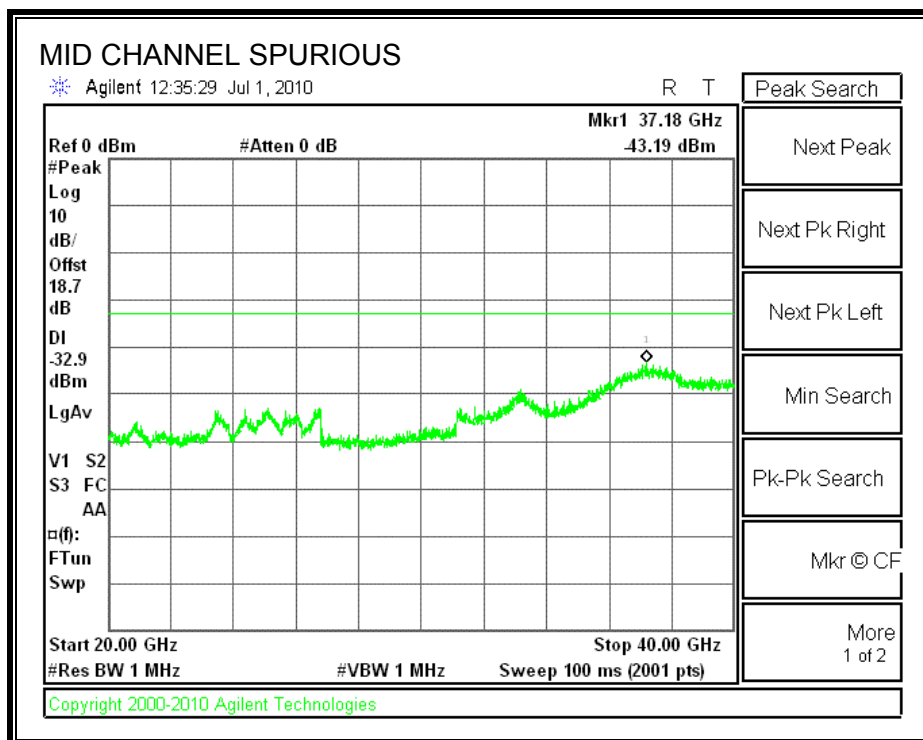
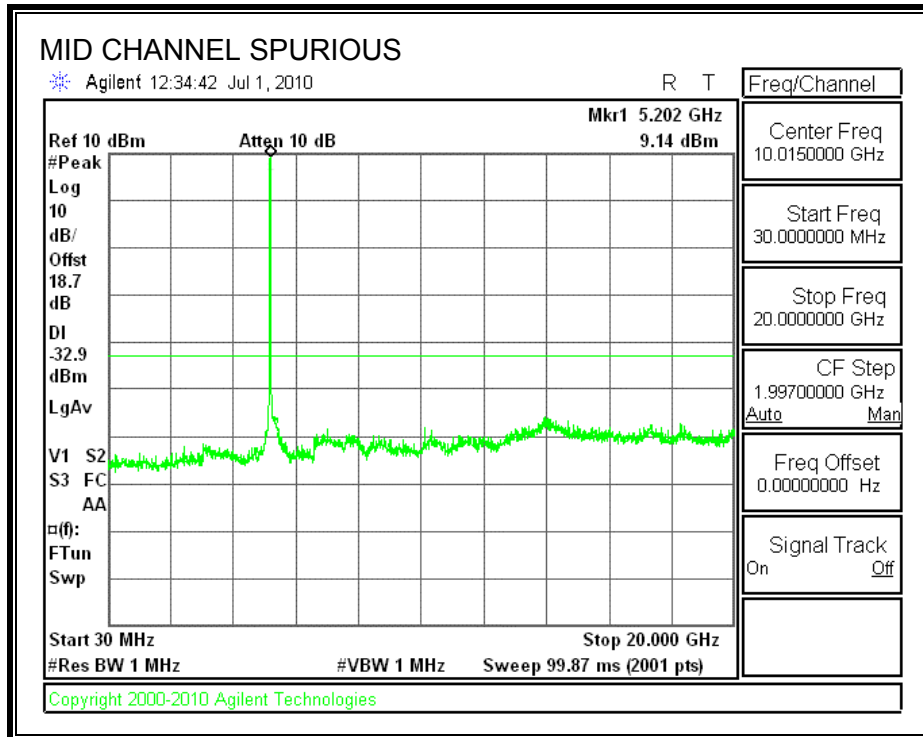

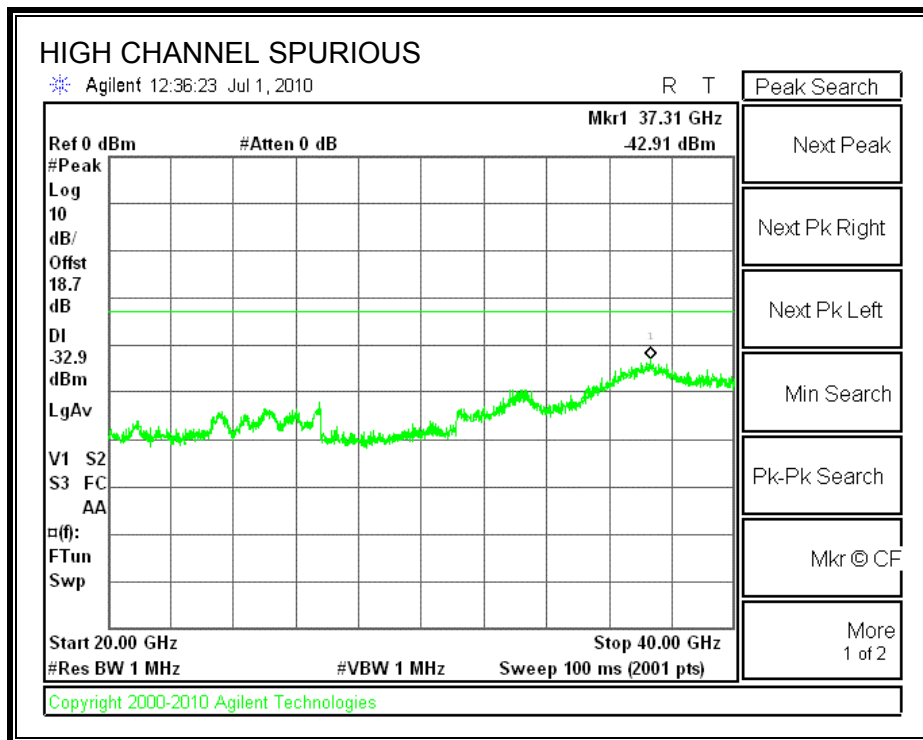
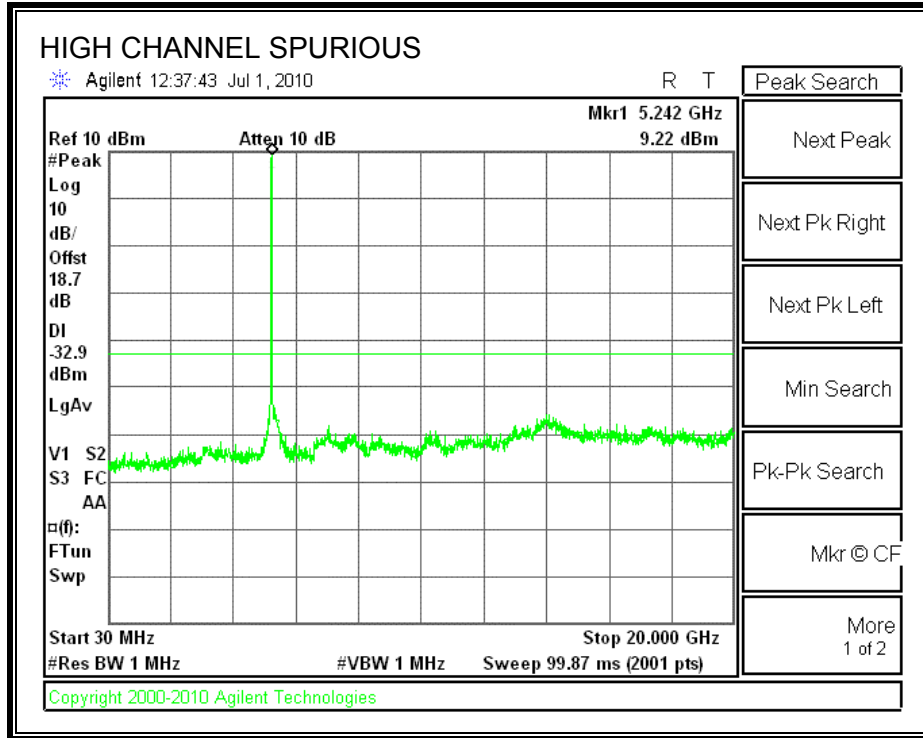

## 7.2. 802.11n HT20 MODE IN THE 5.2 GHz BAND

### HT20 MCS8 SDM – Non-Coherent

#### 7.2.1. 26 dB and 99% BANDWIDTH

##### LIMITS

None; for reporting purposes only.

##### TEST PROCEDURE

The transmitter outputs are connected to the spectrum analyzer via a combiner. The RBW is set to 1% to 3% of the measured bandwidth. The VBW is set to 3 times the RBW. The sweep time is coupled. The spectrum analyzer internal bandwidth function is utilized.

##### RESULTS

###### CHAIN 0

Channel	Frequency (MHz)	26 dB Bandwidth (MHz)	99% Bandwidth (MHz)
Low	5180	18.938	17.3961
High	5240	18.884	17.5113

###### CHAIN 1

Channel	Frequency (MHz)	26 dB Bandwidth (MHz)	99% Bandwidth (MHz)
Low	5180	18.240	17.5933
High	5240	18.744	17.5338

**CHAIN 0**

**26 dB and 99% BANDWIDTH**

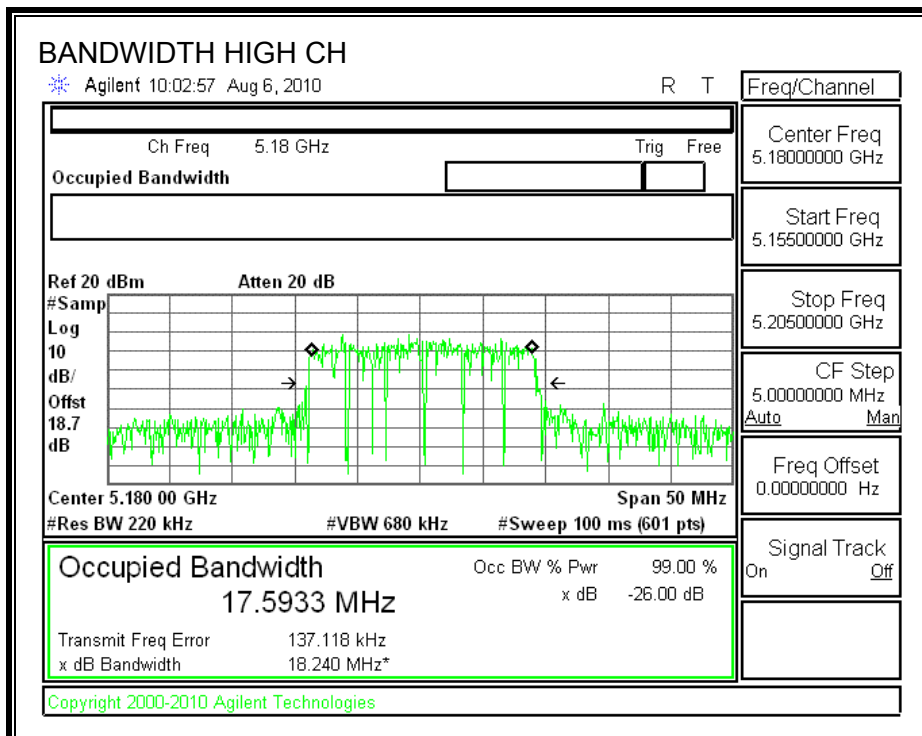
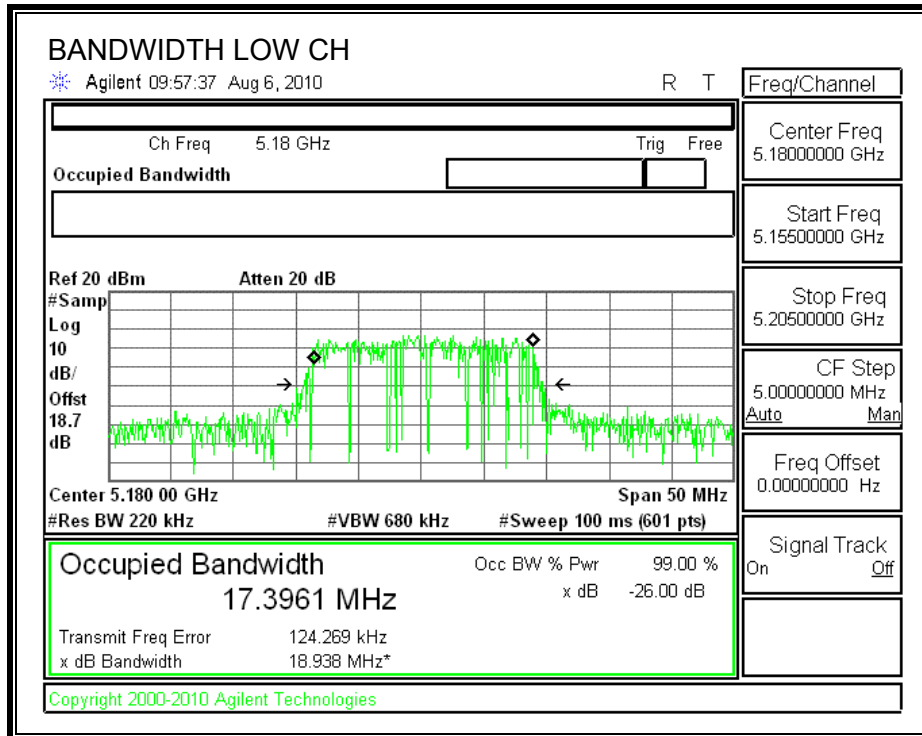

**CHAIN 1**

**26 dB and 99% BANDWIDTH**

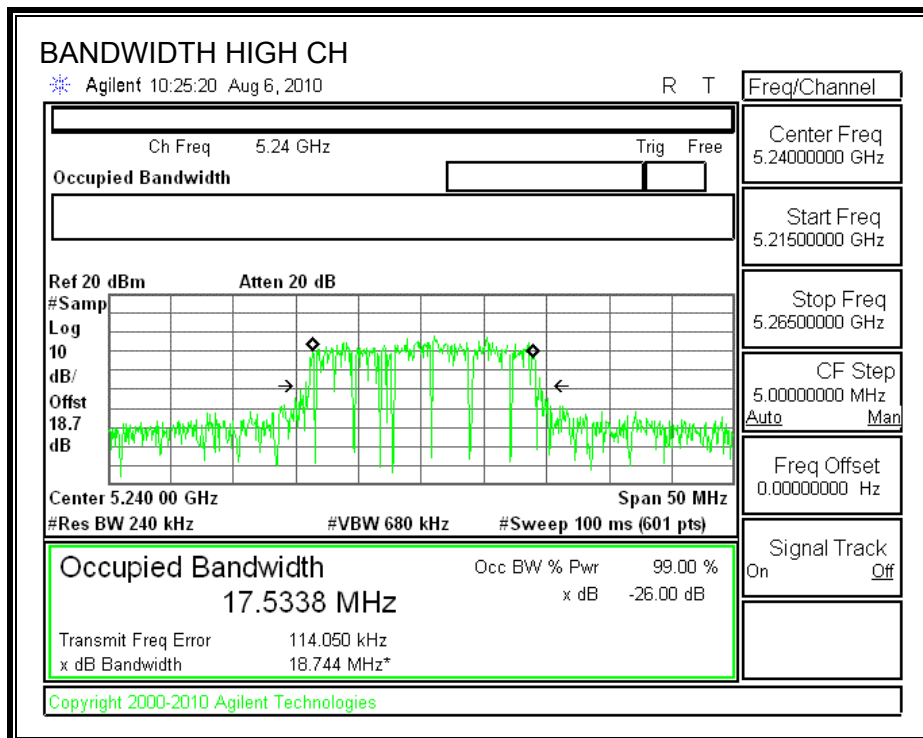
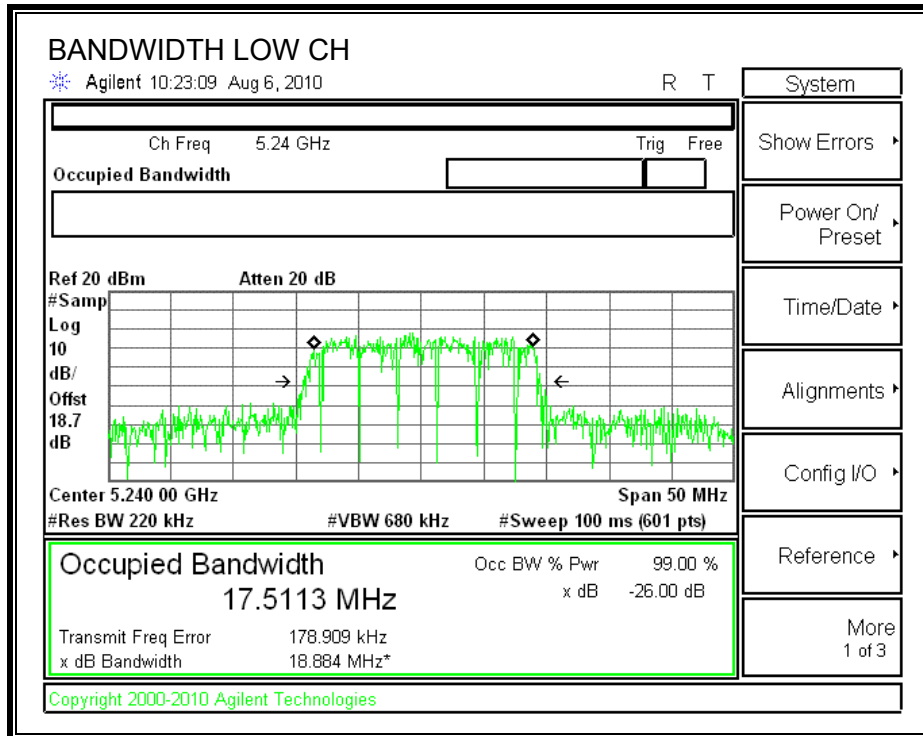



## 7.2.2. OUTPUT POWER

### LIMITS

FCC §15.407 (a) (1)

IC RSS-210 A9.2 (1)

For the 5.15-5.25 GHz band, the maximum conducted output power over the frequency band of operation shall not exceed the lesser of 50 mW or  $4 \text{ dBm} + 10 \log B$ , where B is the 26-dB emission bandwidth in MHz. If transmitting antennas of directional gain greater than 6 dBi are used, both the peak transmit power and the peak power spectral density shall be reduced by the amount in dB that the directional gain of the antenna exceeds 6 dBi.

The composite antenna gain is 5.93 dBi.

### TEST PROCEDURE

The test is performed in accordance with FCC Public Notice: APPENDIX A Guidelines for Assessing Unlicensed National Information Infrastructure (U-NII) Devices – Part 15, Subpart E, August 2002.

The transmitter output operates continuously therefore Method # 1 is used.

**RESULTS**

**Limit**

Channel	Frequency (MHz)	Fixed Limit (dBm)	B (MHz)	4 + 10 Log B Limit (dBm)	Antenna Gain (dBi)	Limit (dBm)
Low	5180	17	18.938	16.77	5.93	16.77
High	5240	17	18.884	16.76	5.93	16.76

**Individual Chain Results**

Channel	Frequency (MHz)	Chain 0 Power (dBm)	Chain 1 Power (dBm)	Total Power (dBm)	Limit (dBm)	Margin (dB)
Low	5180	10.16	9.91	13.05	16.77	-3.73
High	5240	10.53	9.25	12.95	16.76	-3.81

**CHAIN 0 OUTPUT POWER**

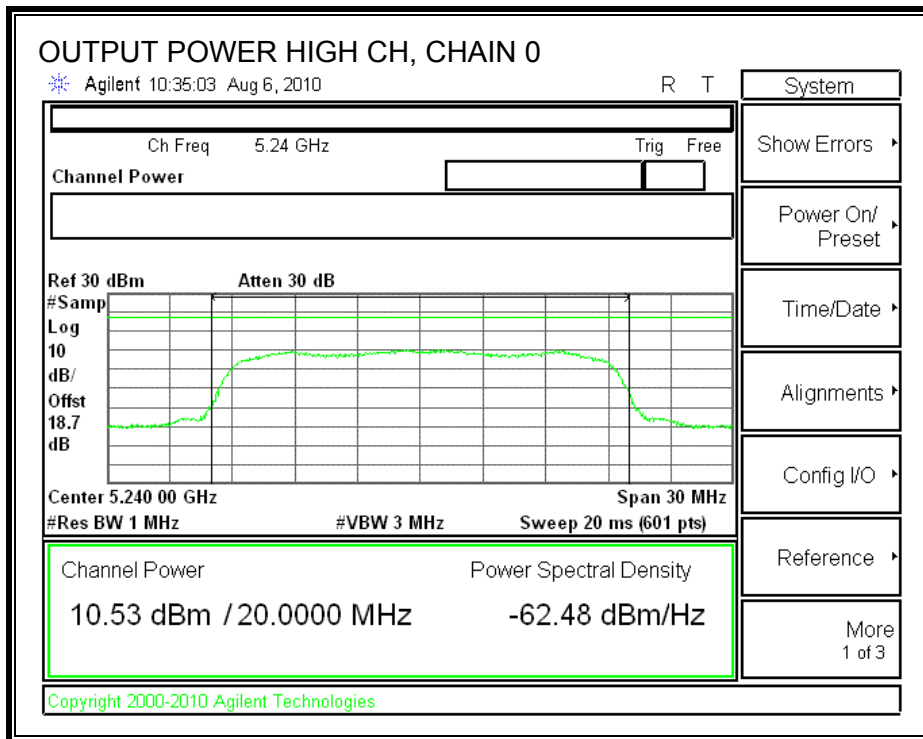
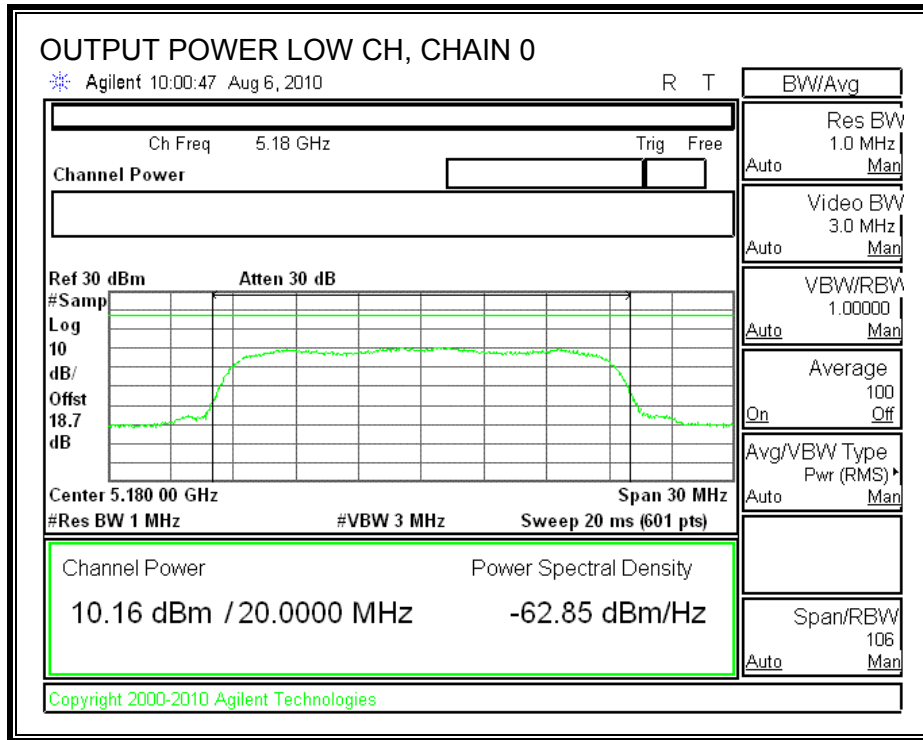

**CHAIN 1 OUTPUT POWER**

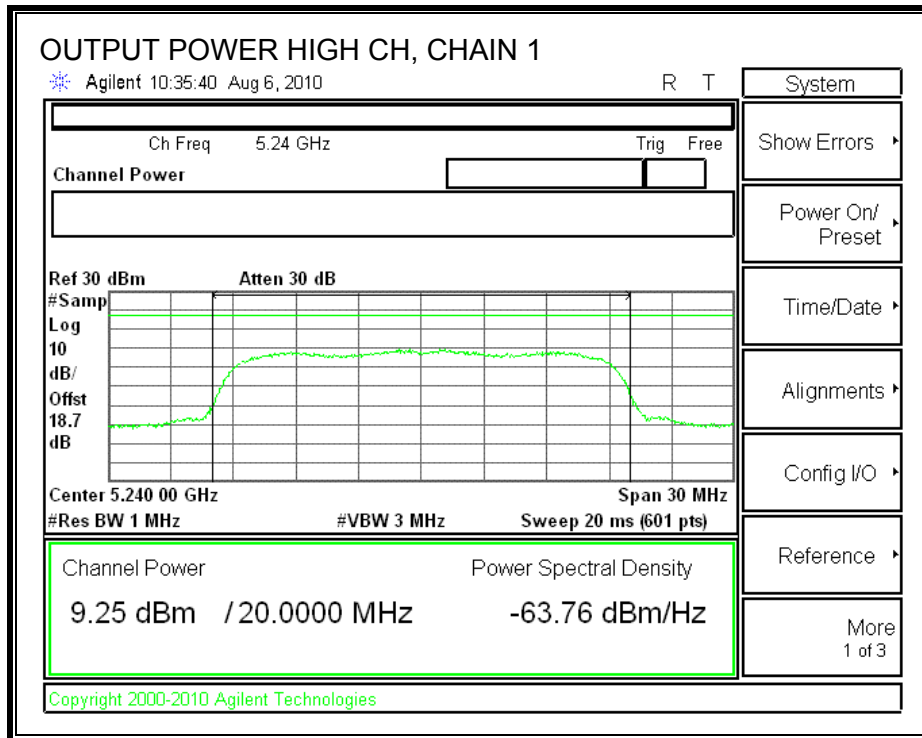
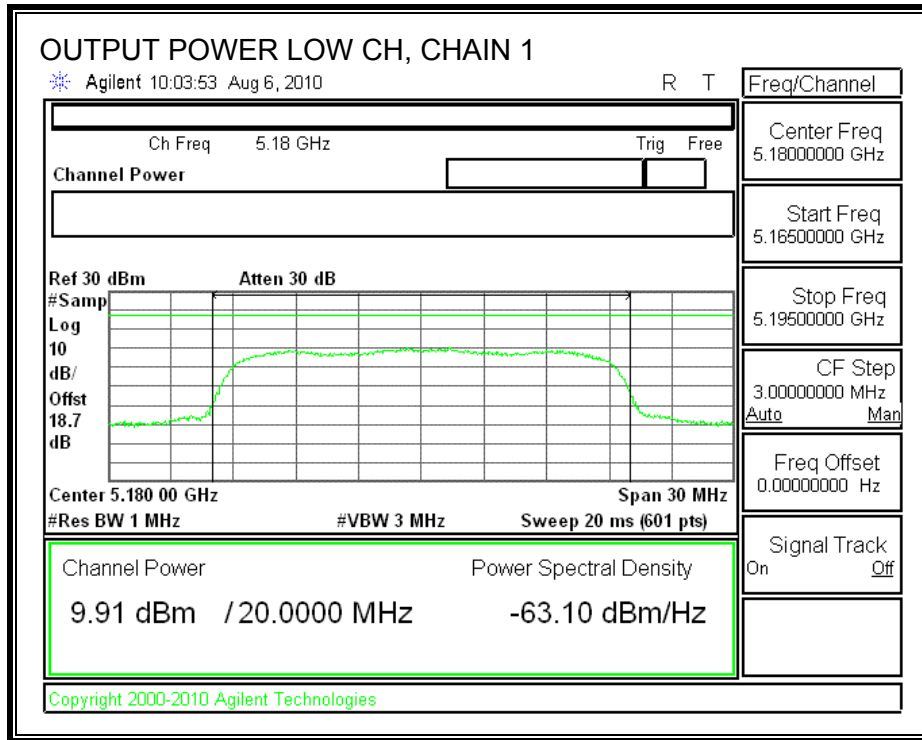

### 7.2.3. PEAK POWER SPECTRAL DENSITY

#### LIMITS

FCC §15.407 (a) (1)

IC RSS-210 A9.2 (1)

For the 5.15-5.25 GHz band, the peak power spectral density shall not exceed 4 dBm in any 1 MHz band. If transmitting antennas of directional gain greater than 6 dBi are used, both the peak transmit power and the peak power spectral density shall be reduced by the amount in dB that the directional gain of the antenna exceeds 6 dBi.

The composite antenna gain is 5.93 dBi, therefore the limit is 4 dBm.

#### TEST PROCEDURE

The test is performed in accordance with FCC Public Notice: APPENDIX A Guidelines for Assessing Unlicensed National Information Infrastructure (U-NII) Devices – Part 15, Subpart E, August 2002. PPSD method #2 was used.

#### RESULTS

Channel	Frequency (MHz)	PPSD With Combiner (dBm)	Limit (dBm)	Margin (dB)
Low	5180	2.836	4.00	-1.16
High	5240	2.499	4.00	-1.50

**POWER SPECTRAL DENSITY WITH COMBINER**

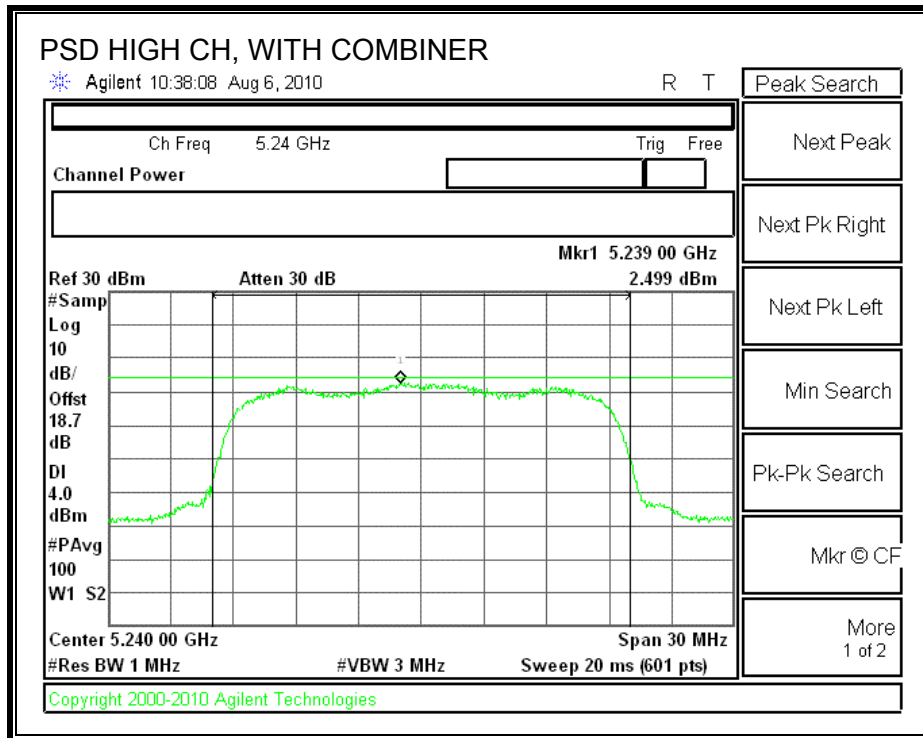
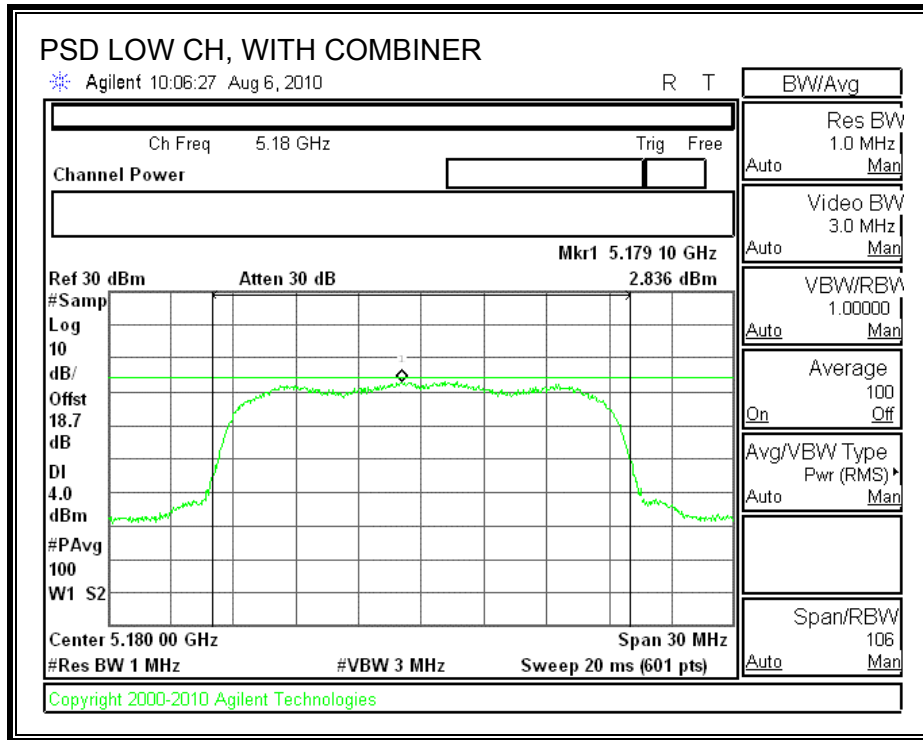

## 7.2.4. PEAK EXCURSION

### LIMITS

FCC §15.407 (a) (6)

The ratio of the peak excursion of the modulation envelope (measured using a peak hold function) to the peak transmit power (measured as specified above) shall not exceed 13 dB across any 1 MHz bandwidth or the emission bandwidth whichever is less.

### TEST PROCEDURE

The transmitter outputs are connected to the spectrum analyzer via a combiner.

The test is performed in accordance with FCC Public Notice: APPENDIX A Guidelines for Assessing Unlicensed National Information Infrastructure (U-NII) Devices – Part 15, Subpart E, August 2002.

Since Method # 1 was used for peak power measurements, Method # 1 settings are used for the second PPSD trace.

### RESULTS

#### CHAIN 0

Channel	Frequency (MHz)	Peak Excursion (dB)	Limit (dB)	Margin (dB)
Low	5180	9.55	13	-3.45
High	5240	8.96	13	-4.04

#### CHAIN 1

Channel	Frequency (MHz)	Peak Excursion (dB)	Limit (dB)	Margin (dB)
Low	5180	10.12	13	-2.88
High	5240	10.24	13	-2.76

**CHAIN 0**

**PEAK EXCURSION**

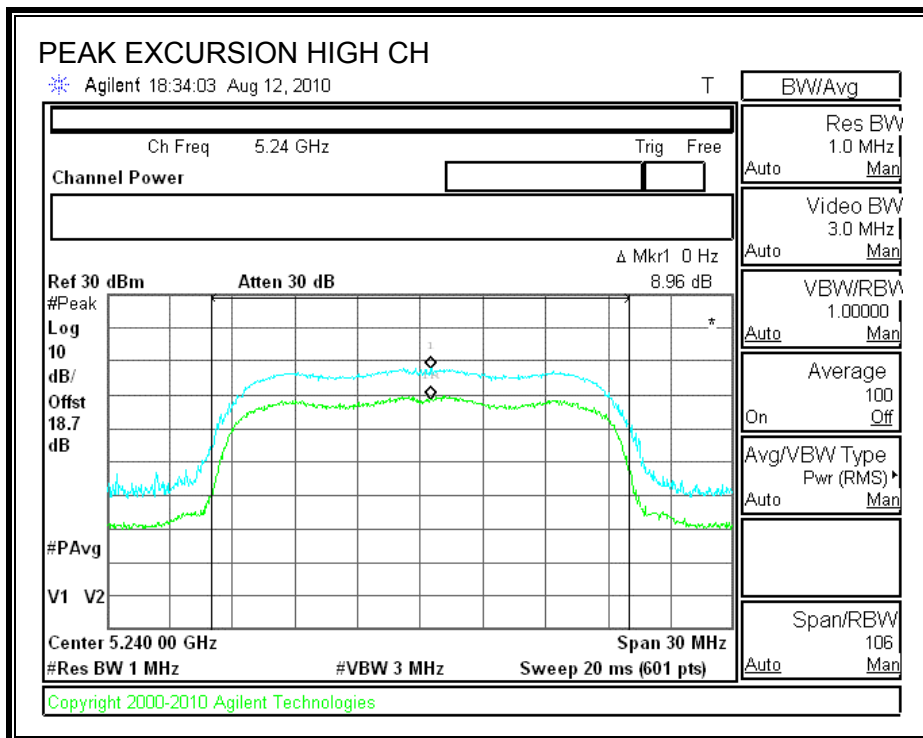
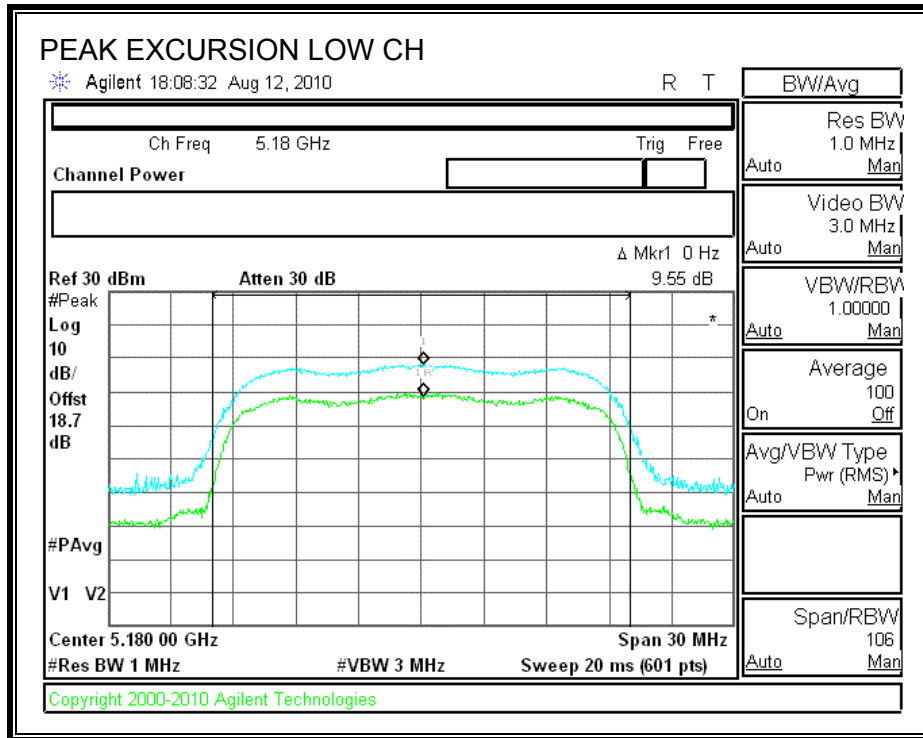



**CHAIN 1**

**PEAK EXCURSION**

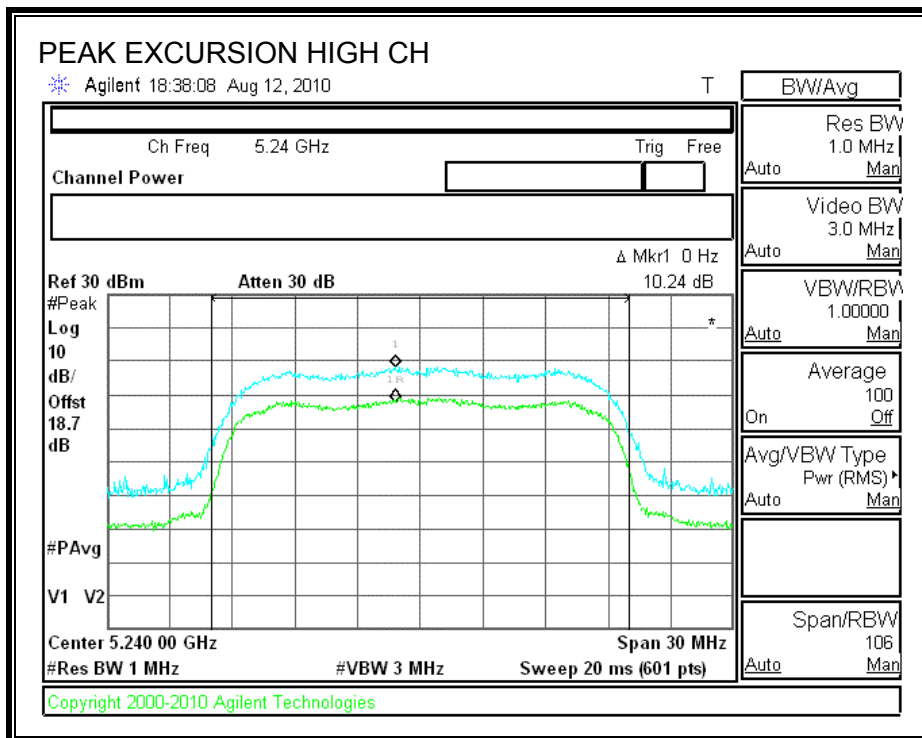
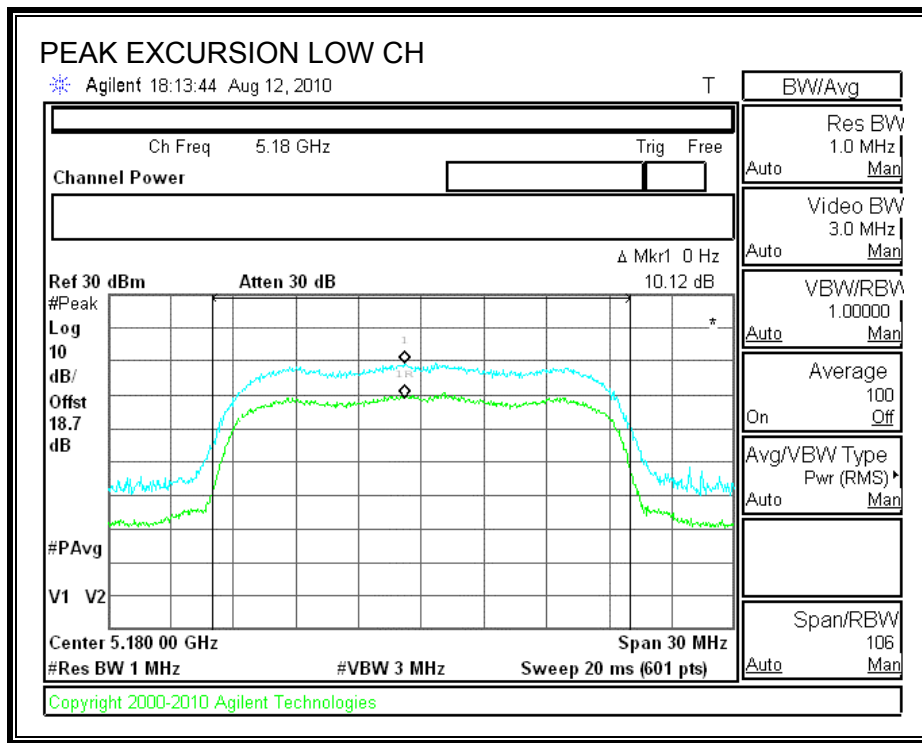

## 7.2.5. CONDUCTED SPURIOUS EMISSIONS

### LIMITS

FCC §15.407 (b) (1)

IC RSS-210 A9.3 (1)

For transmitters operating in the 5.15-5.25 GHz band: all emissions outside of the 5.15-5.35 GHz band shall not exceed an EIRP of -27 dBm / MHz.

### TEST PROCEDURE

Conducted RF measurements of the transmitter output are made to confirm that the EUT antenna port conducted emissions meet the specified limit and to identify any spurious signals that require further investigation or measurements on the radiated emissions site.

The transmitter output is connected to the spectrum analyzer. The resolution bandwidth is set to 1 MHz. The video bandwidth is set to 1 MHz. Peak detection measurements are compared to EIRP limit, adjusted for the maximum antenna gain.

Measurements are made over the 30 MHz to 40 GHz range with the transmitter set to the lowest, middle, and highest channels.

**SPURIOUS EMISSIONS**

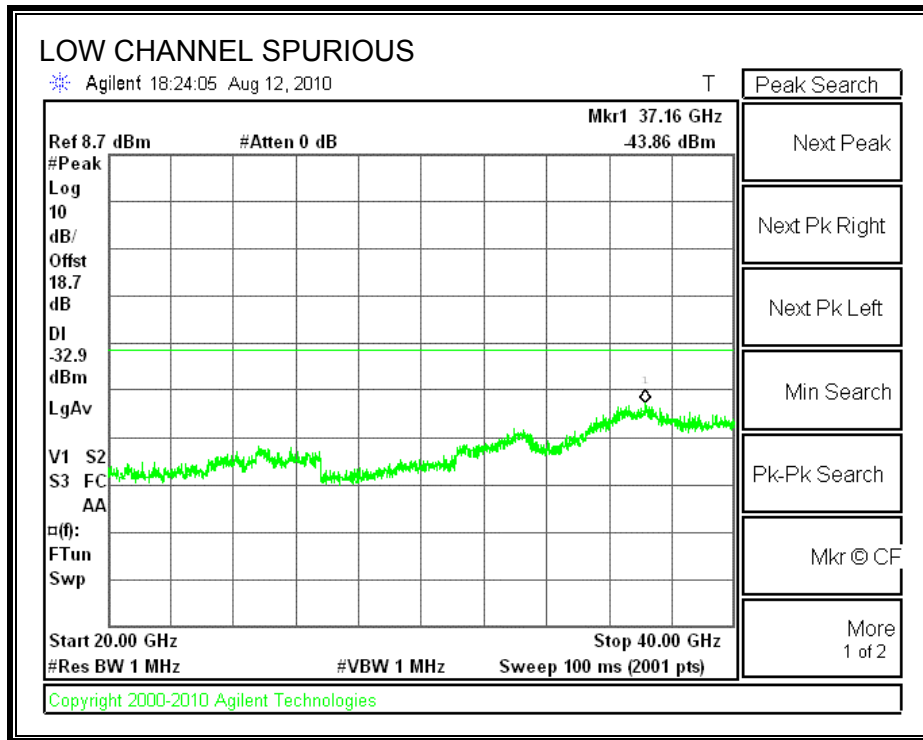
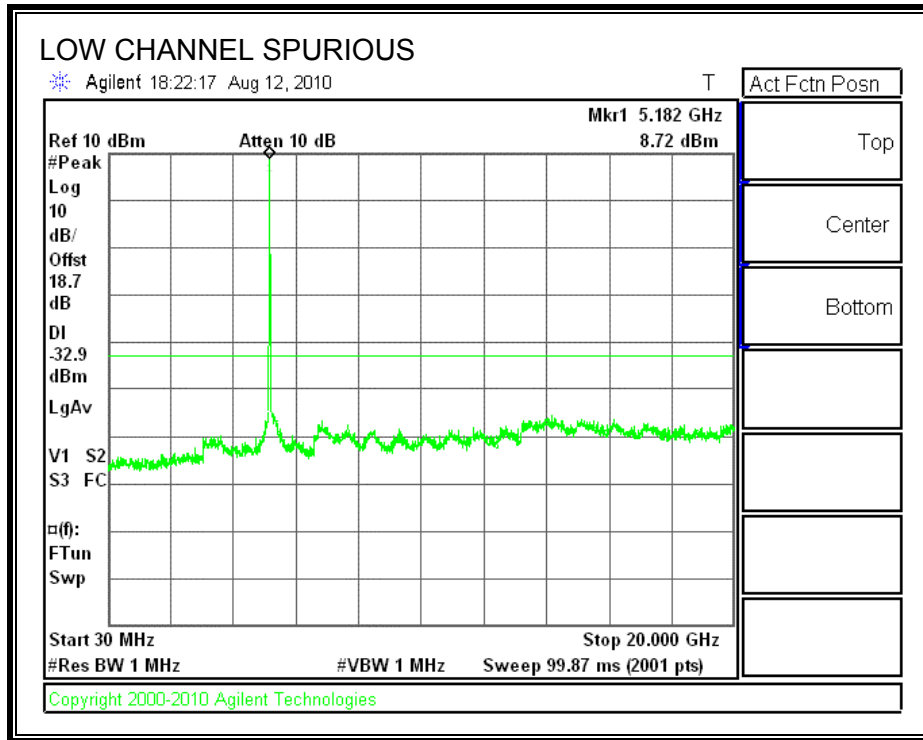

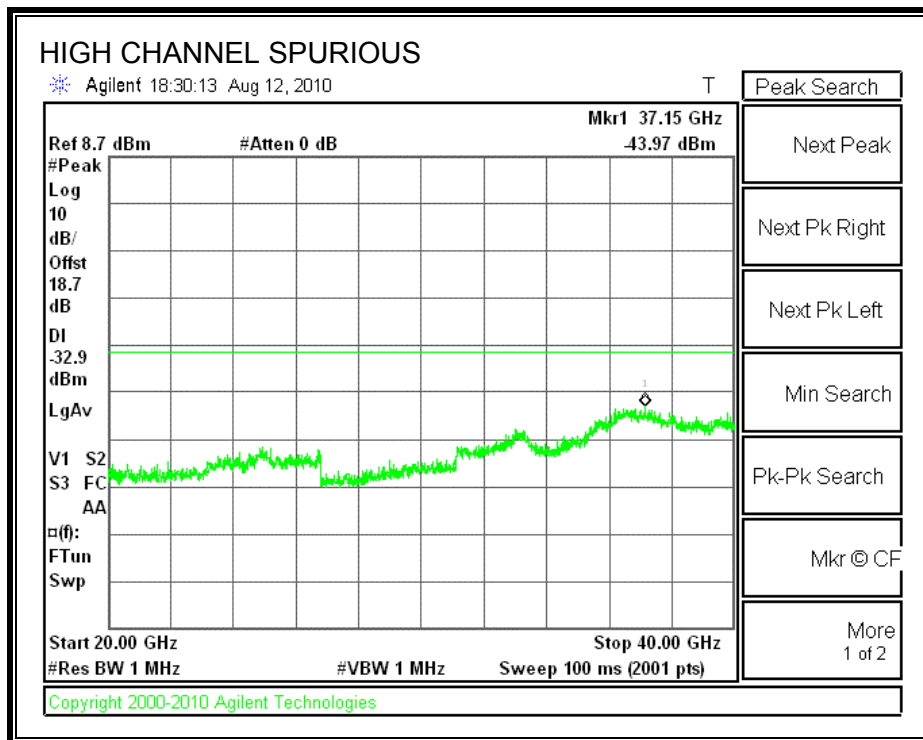
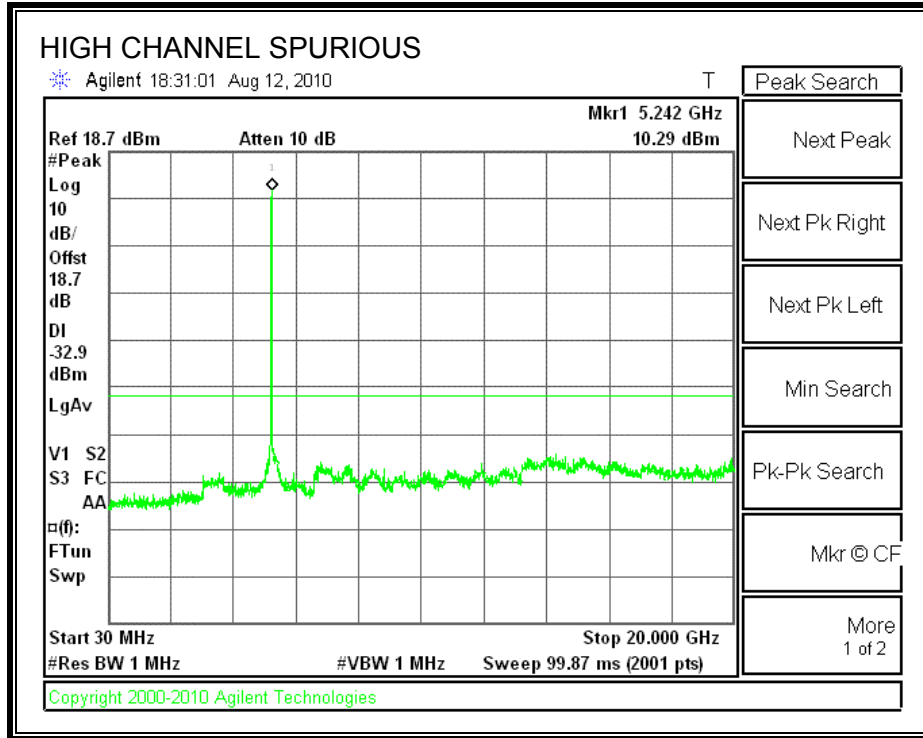

**HT20 MCS12 SDM – Non-Coherent**

**7.2.6. 26 dB and 99% BANDWIDTH**

**LIMITS**

None; for reporting purposes only.

**TEST PROCEDURE**

The transmitter outputs are connected to the spectrum analyzer via a combiner. The RBW is set to 1% to 3% of the measured bandwidth. The VBW is set to 3 times the RBW. The sweep time is coupled. The spectrum analyzer internal bandwidth function is utilized.

**RESULTS**

**CHAIN 0**

Channel	Frequency (MHz)	26 dB Bandwidth (MHz)	99% Bandwidth (MHz)
Low	5180	18.725	17.2658
High	5240	18.538	17.6357

**CHAIN 1**

Channel	Frequency (MHz)	26 dB Bandwidth (MHz)	99% Bandwidth (MHz)
Low	5180	18.583	17.3392
High	5240	18.524	17.5491

**CHAIN 0**

**26 dB and 99% BANDWIDTH**

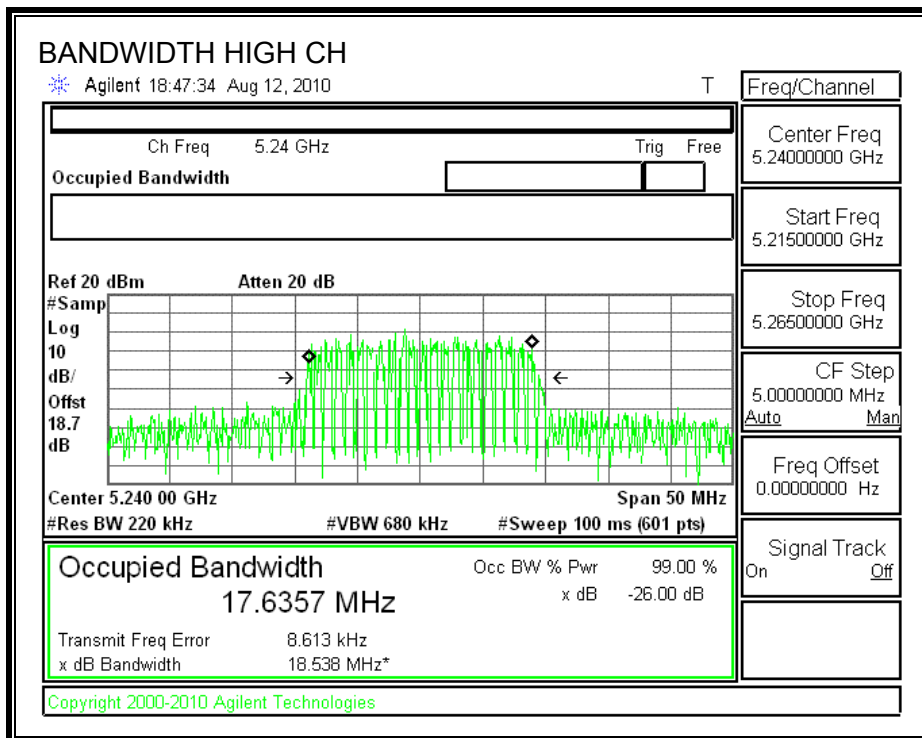
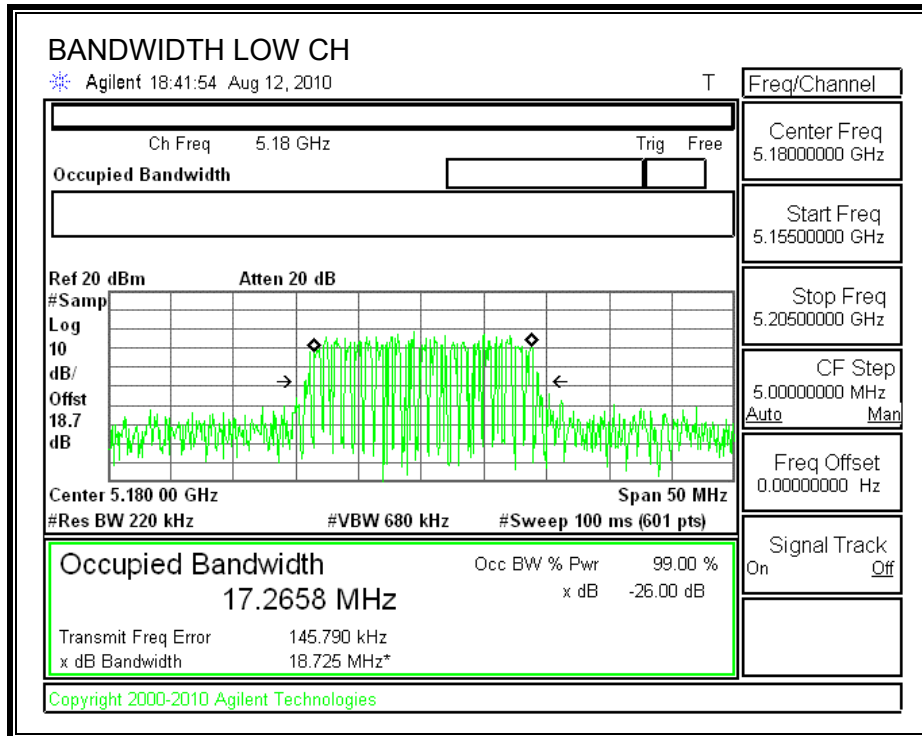

**CHAIN 1**

**26 dB and 99% BANDWIDTH**

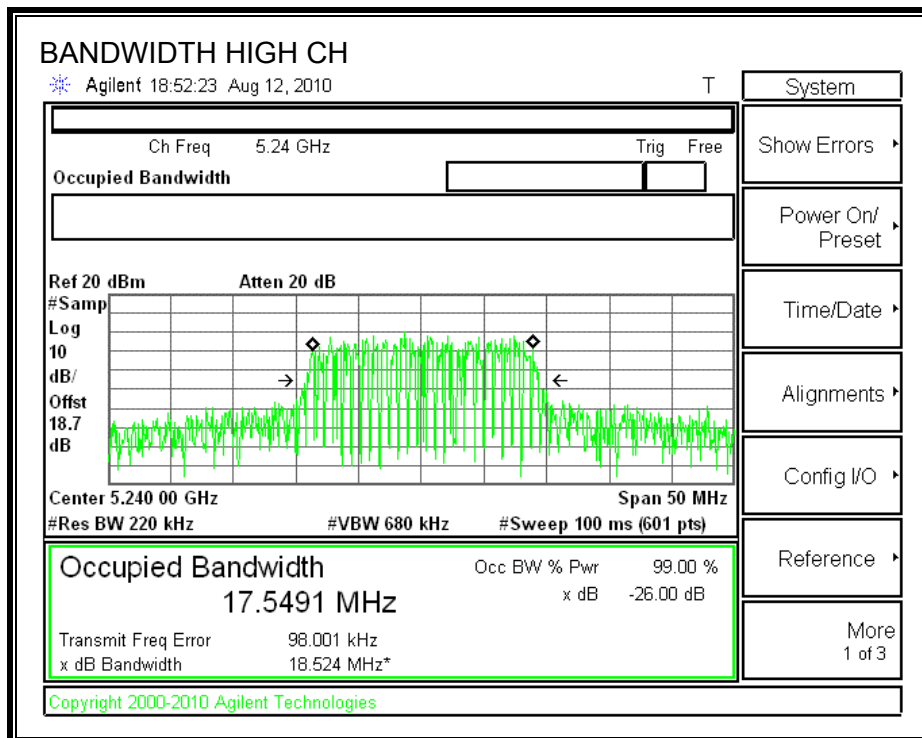
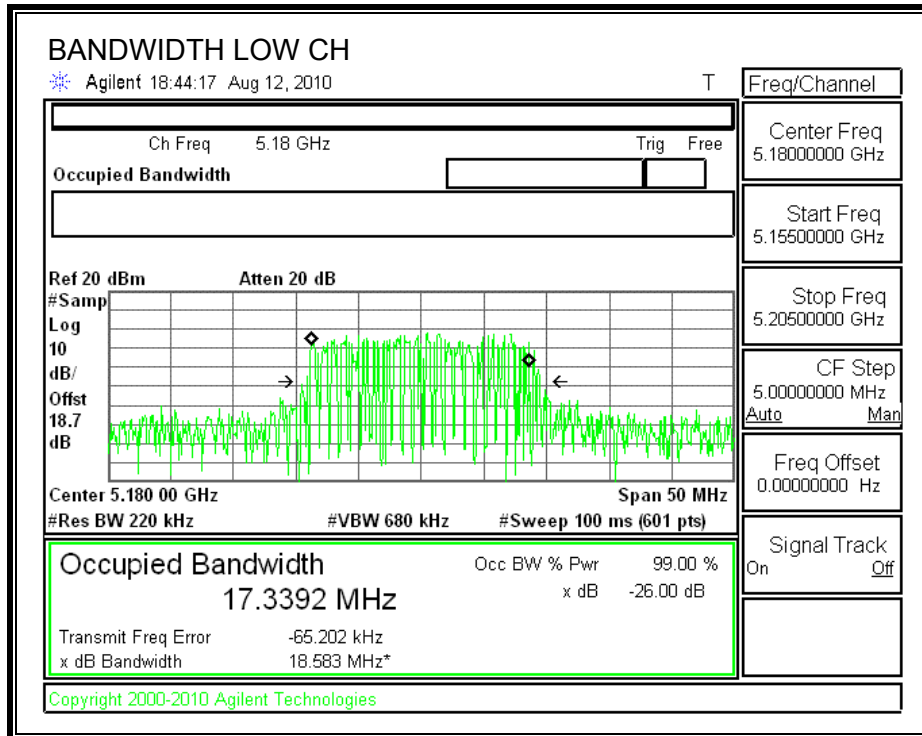

## 7.2.7. OUTPUT POWER

### LIMITS

FCC §15.407 (a) (1)

IC RSS-210 A9.2 (1)

For the 5.15-5.25 GHz band, the maximum conducted output power over the frequency band of operation shall not exceed the lesser of 50 mW or  $4 \text{ dBm} + 10 \log B$ , where B is the 26-dB emission bandwidth in MHz. If transmitting antennas of directional gain greater than 6 dBi are used, both the peak transmit power and the peak power spectral density shall be reduced by the amount in dB that the directional gain of the antenna exceeds 6 dBi.

The composite antenna gain is 5.93 dBi.

### TEST PROCEDURE

The test is performed in accordance with FCC Public Notice: APPENDIX A Guidelines for Assessing Unlicensed National Information Infrastructure (U-NII) Devices – Part 15, Subpart E, August 2002.

The transmitter output operates continuously therefore Method # 1 is used.



**RESULTS**

**Limit**

Channel	Frequency (MHz)	Fixed Limit (dBm)	B (MHz)	4 + 10 Log B Limit (dBm)	Antenna Gain (dBi)	Limit (dBm)
Low	5180	17	18.538	16.68	5.93	16.68
High	5240	17	18.725	16.72	5.93	16.72

**Individual Chain Results**

Channel	Frequency (MHz)	Chain 0 Power (dBm)	Chain 1 Power (dBm)	Total Power (dBm)	Limit (dBm)	Margin (dB)
Low	5180	9.02	10.06	12.58	16.68	-4.10
High	5240	9.72	9.38	12.56	16.72	-4.16

**CHAIN 0 OUTPUT POWER**

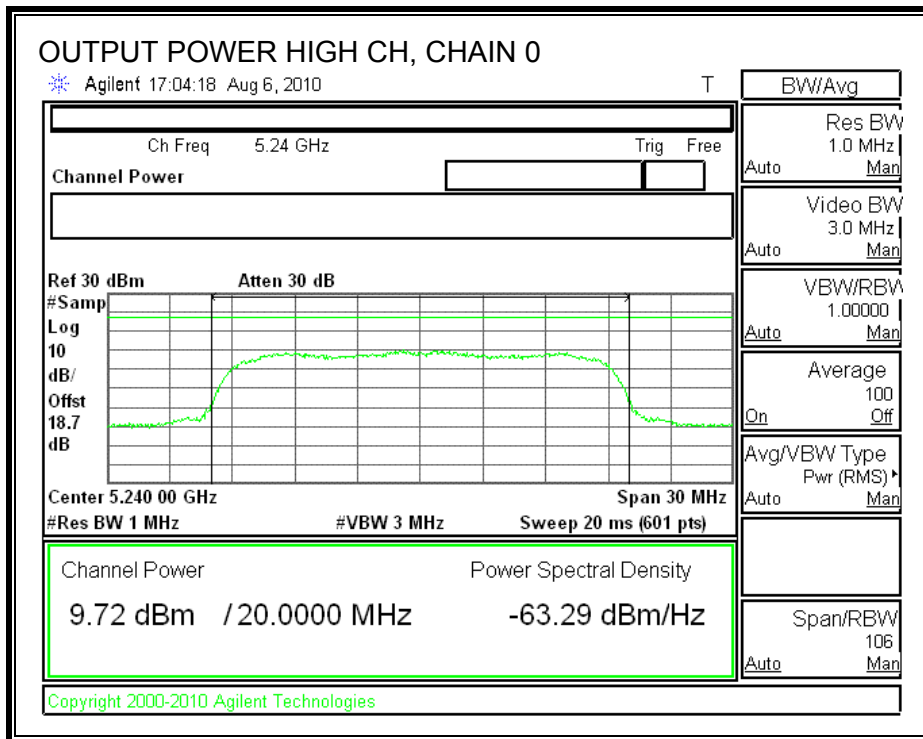
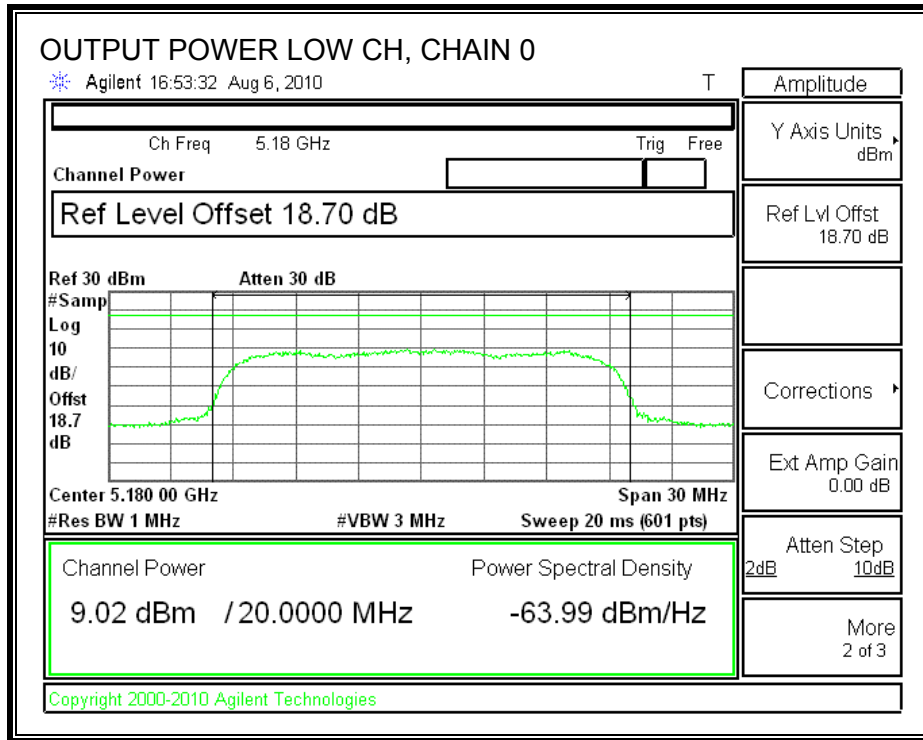

**CHAIN 1 OUTPUT POWER**

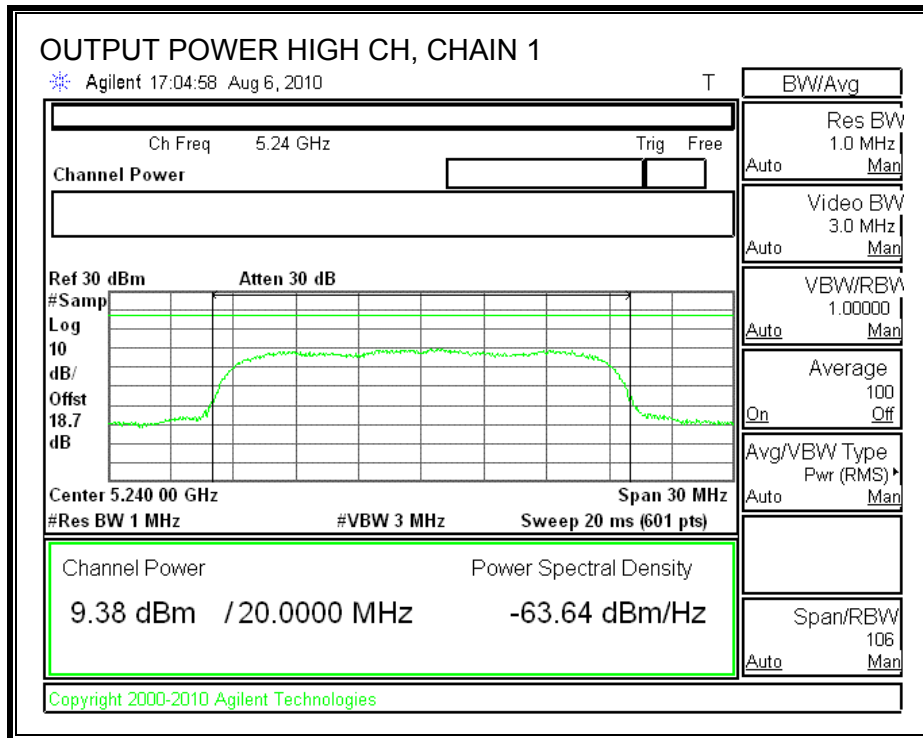
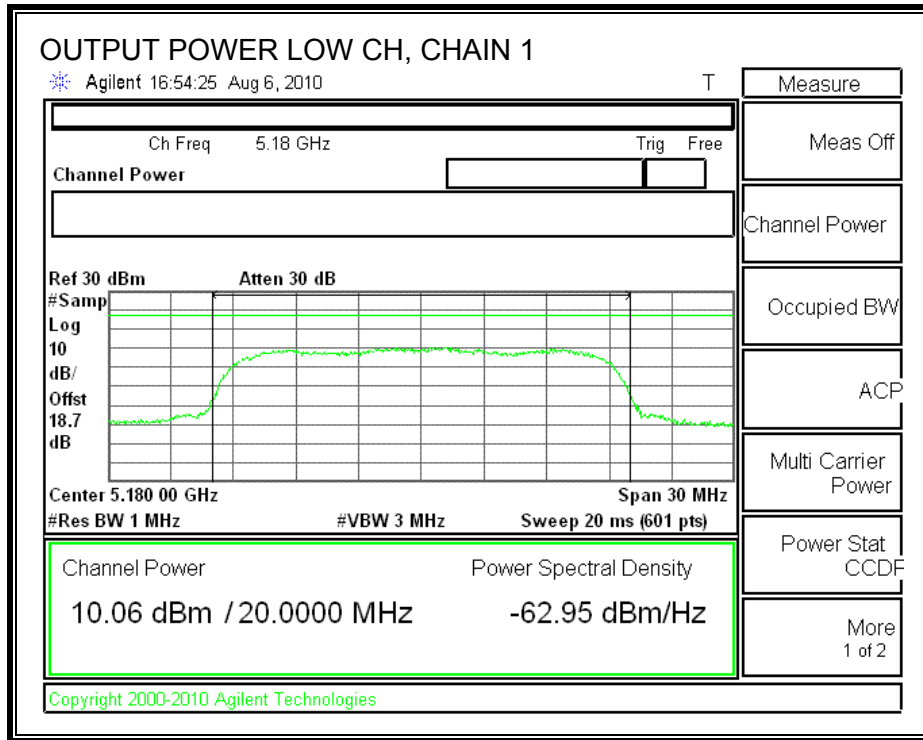

## 7.2.8. PEAK POWER SPECTRAL DENSITY

### LIMITS

FCC §15.407 (a) (1)

IC RSS-210 A9.2 (1)

For the 5.15-5.25 GHz band, the peak power spectral density shall not exceed 4 dBm in any 1 MHz band. If transmitting antennas of directional gain greater than 6 dBi are used, both the peak transmit power and the peak power spectral density shall be reduced by the amount in dB that the directional gain of the antenna exceeds 6 dBi.

The composite antenna gain is 5.93 dBi, therefore the limit is 4 dBm.

### TEST PROCEDURE

The test is performed in accordance with FCC Public Notice: APPENDIX A Guidelines for Assessing Unlicensed National Information Infrastructure (U-NII) Devices – Part 15, Subpart E, August 2002. PPSD method #2 was used.

### RESULTS

Channel	Frequency (MHz)	PPSD With Combiner (dBm)	Limit (dBm)	Margin (dB)
Low	5180	3.173	4.00	-0.83
High	5240	3.210	4.00	-0.79

**POWER SPECTRAL DENSITY WITH COMBINER**

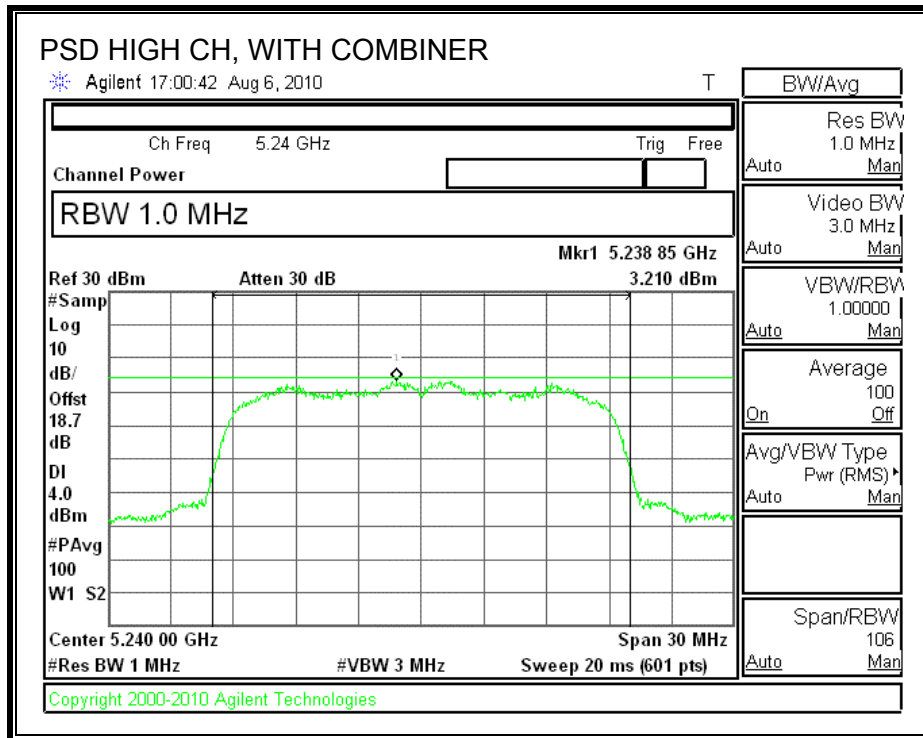
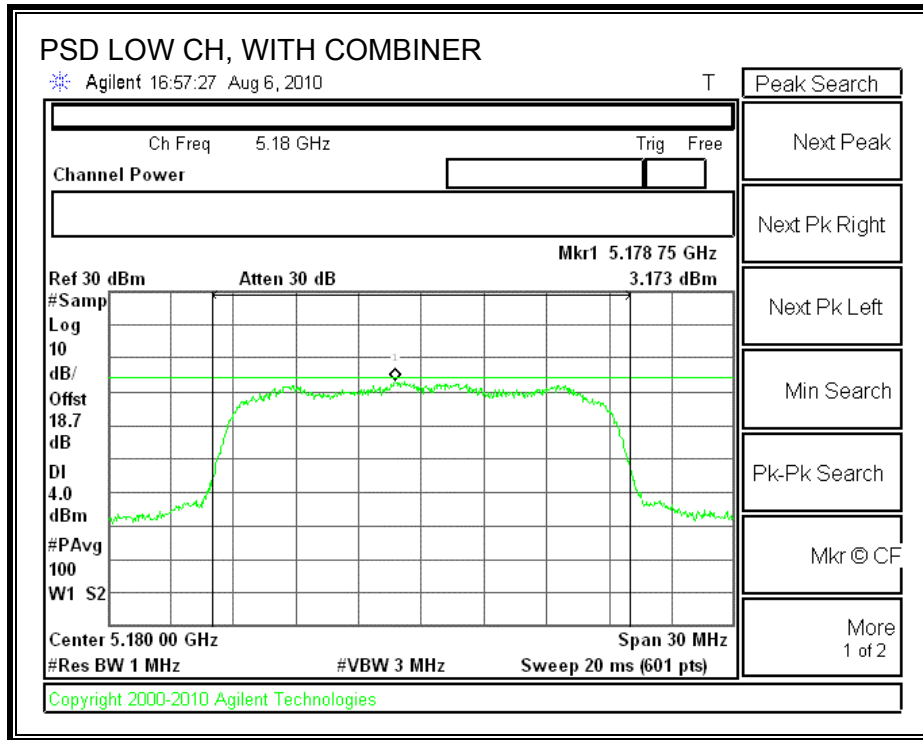

## 7.2.9. PEAK EXCURSION

### LIMITS

FCC §15.407 (a) (6)

The ratio of the peak excursion of the modulation envelope (measured using a peak hold function) to the peak transmit power (measured as specified above) shall not exceed 13 dB across any 1 MHz bandwidth or the emission bandwidth whichever is less.

### TEST PROCEDURE

The transmitter outputs are connected to the spectrum analyzer via a combiner.

The test is performed in accordance with FCC Public Notice: APPENDIX A Guidelines for Assessing Unlicensed National Information Infrastructure (U-NII) Devices – Part 15, Subpart E, August 2002.

Since Method # 1 was used for peak power measurements, Method # 1 settings are used for the second PPSD trace.

### RESULTS

#### CHAIN 0

Channel	Frequency (MHz)	Peak Excursion (dB)	Limit (dB)	Margin (dB)
Low	5180	11.75	13	-1.25
High	5240	11.55	13	-1.45

#### CHAIN 1

Channel	Frequency (MHz)	Peak Excursion (dB)	Limit (dB)	Margin (dB)
Low	5180	11.18	13	-1.82
High	5240	11.72	13	-1.28

**CHAIN 0**

**PEAK EXCURSION**

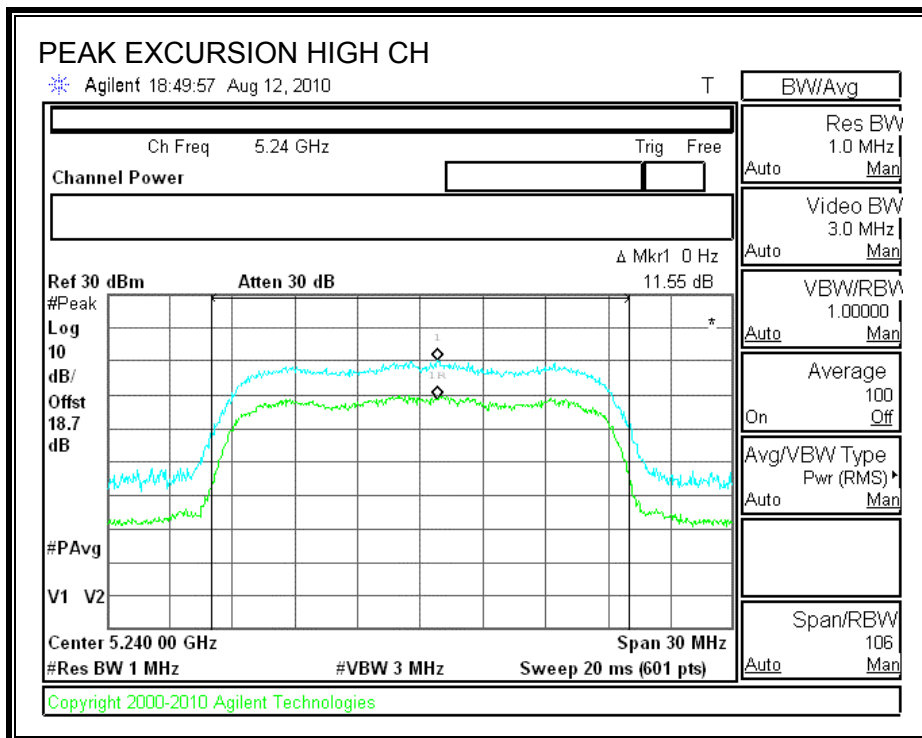
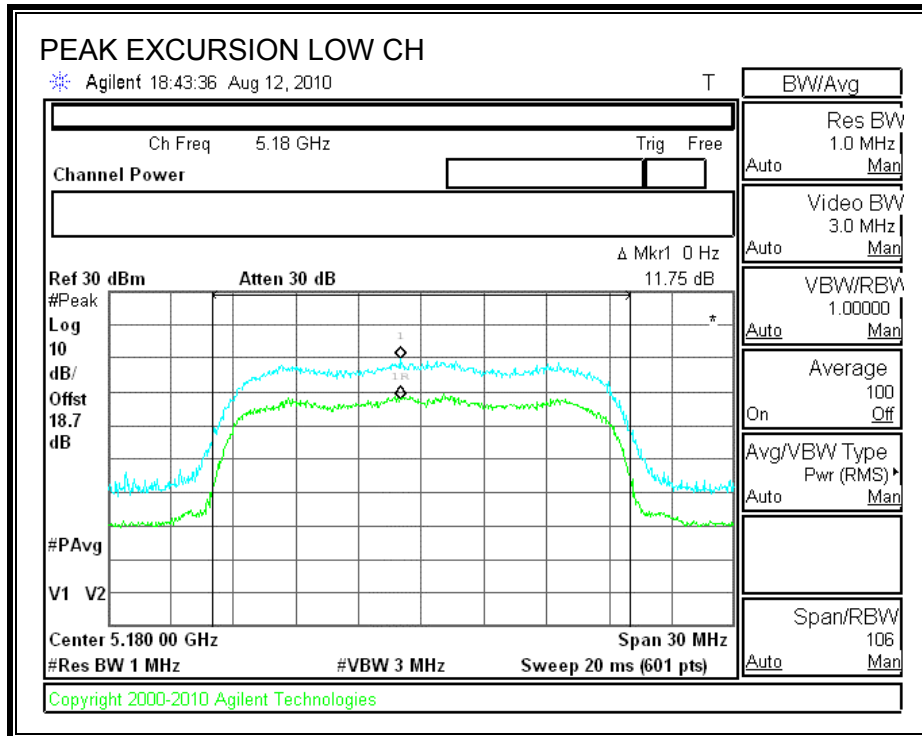

**CHAIN 1**

**PEAK EXCURSION**

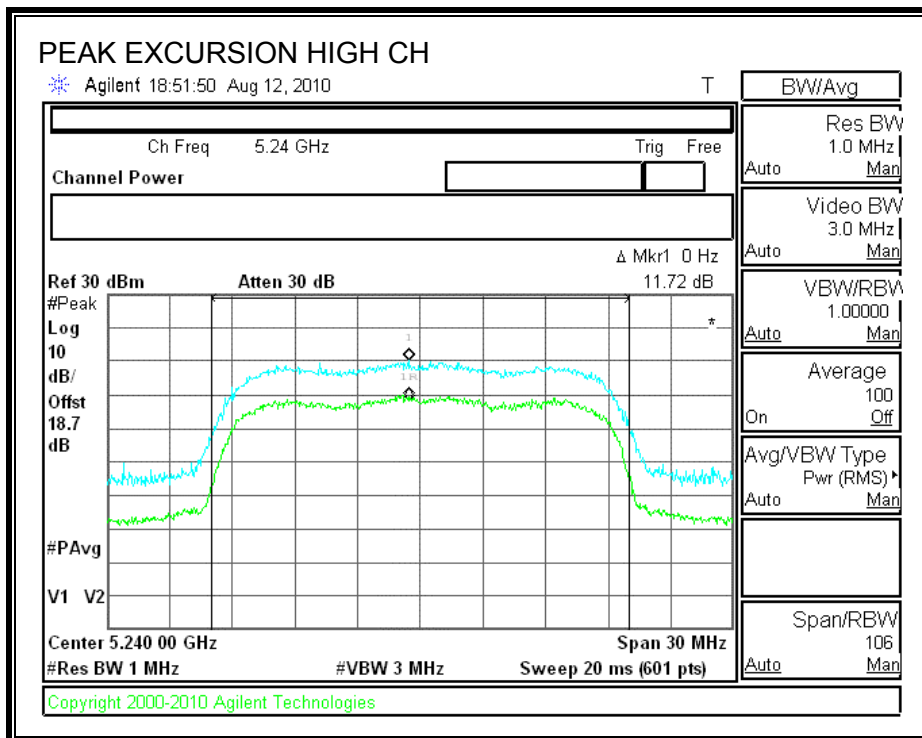
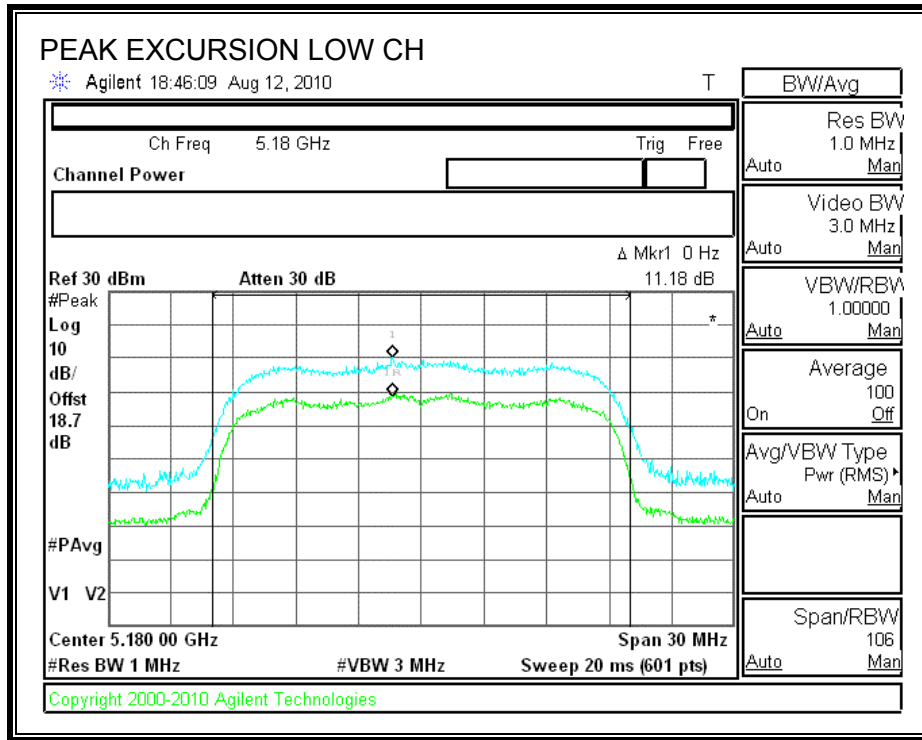



## 7.2.10. CONDUCTED SPURIOUS EMISSIONS

### LIMITS

FCC §15.407 (b) (1)

IC RSS-210 A9.3 (1)

For transmitters operating in the 5.15-5.25 GHz band: all emissions outside of the 5.15-5.35 GHz band shall not exceed an EIRP of -27 dBm / MHz.

### TEST PROCEDURE

Conducted RF measurements of the transmitter output are made to confirm that the EUT antenna port conducted emissions meet the specified limit and to identify any spurious signals that require further investigation or measurements on the radiated emissions site.

The transmitter output is connected to the spectrum analyzer. The resolution bandwidth is set to 1 MHz. The video bandwidth is set to 1 MHz. Peak detection measurements are compared to EIRP limit, adjusted for the maximum antenna gain.

Measurements are made over the 30 MHz to 40 GHz range with the transmitter set to the lowest, middle, and highest channels.

**SPURIOUS EMISSIONS**

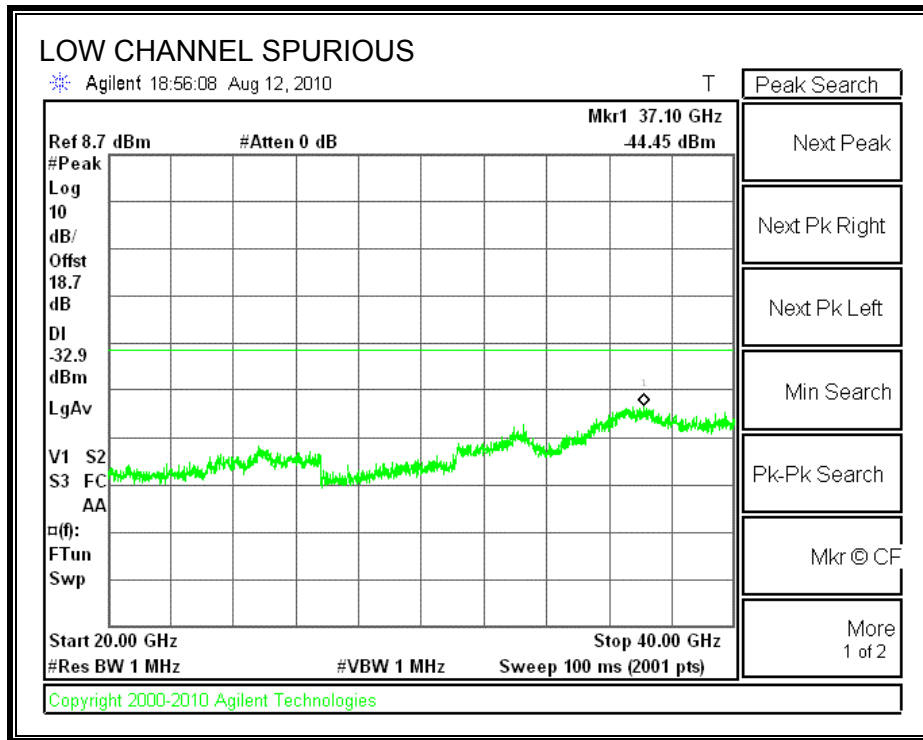
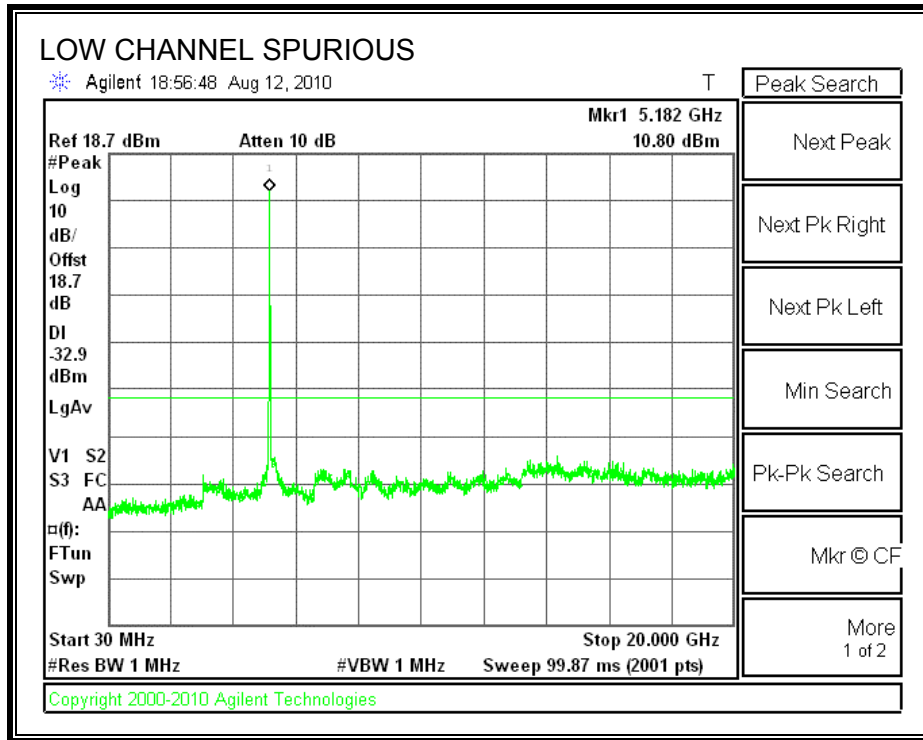

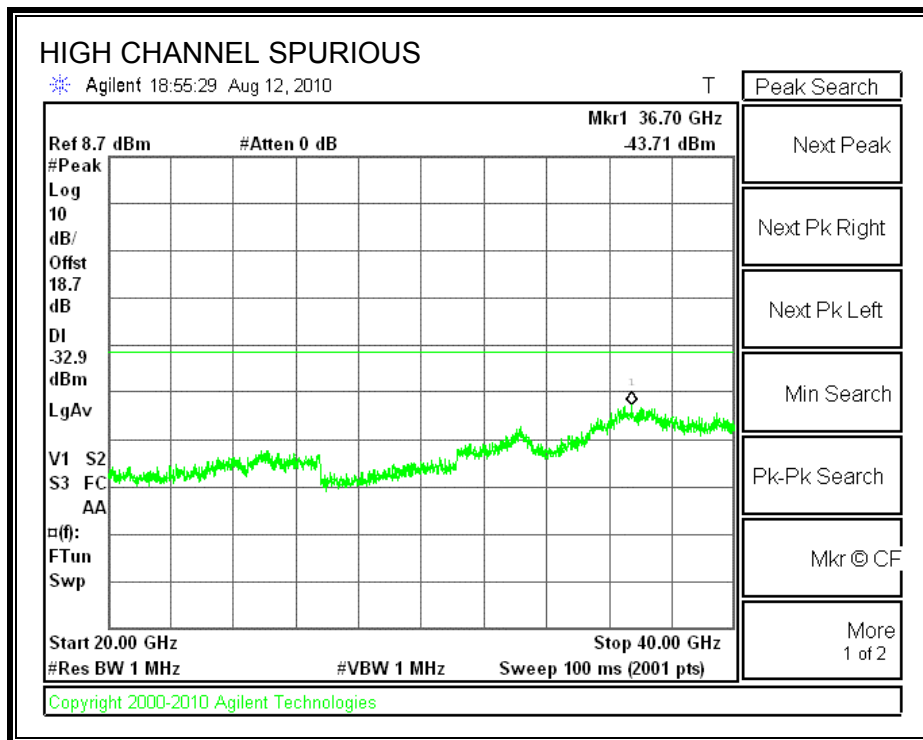
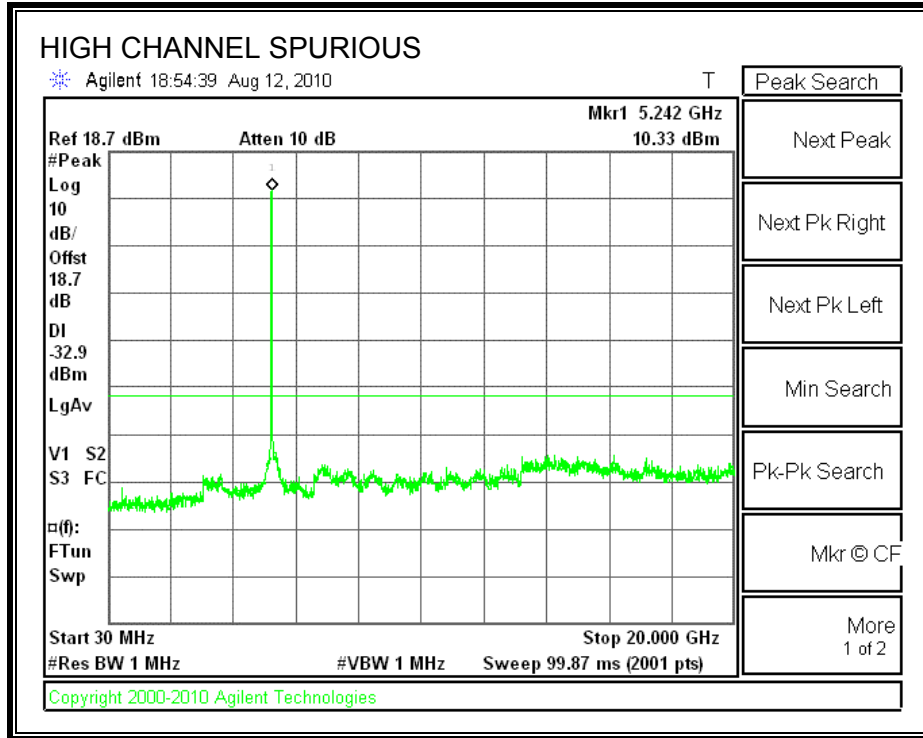

**HT20 MCS15 SDM – Non-Coherent**

**7.2.11. 26 dB and 99% BANDWIDTH**

**LIMITS**

None; for reporting purposes only.

**TEST PROCEDURE**

The transmitter outputs are connected to the spectrum analyzer via a combiner. The RBW is set to 1% to 3% of the measured bandwidth. The VBW is set to 3 times the RBW. The sweep time is coupled. The spectrum analyzer internal bandwidth function is utilized.

**RESULTS**

**CHAIN 0**

Channel	Frequency (MHz)	26 dB Bandwidth (MHz)	99% Bandwidth (MHz)
Low	5180	18.629	17.6453
High	5240	18.469	17.3618

**CHAIN 1**

Channel	Frequency (MHz)	26 dB Bandwidth (MHz)	99% Bandwidth (MHz)
Low	5180	18.350	17.4318
High	5240	18.125	17.4858

**CHAIN 0**

**26 dB and 99% BANDWIDTH**

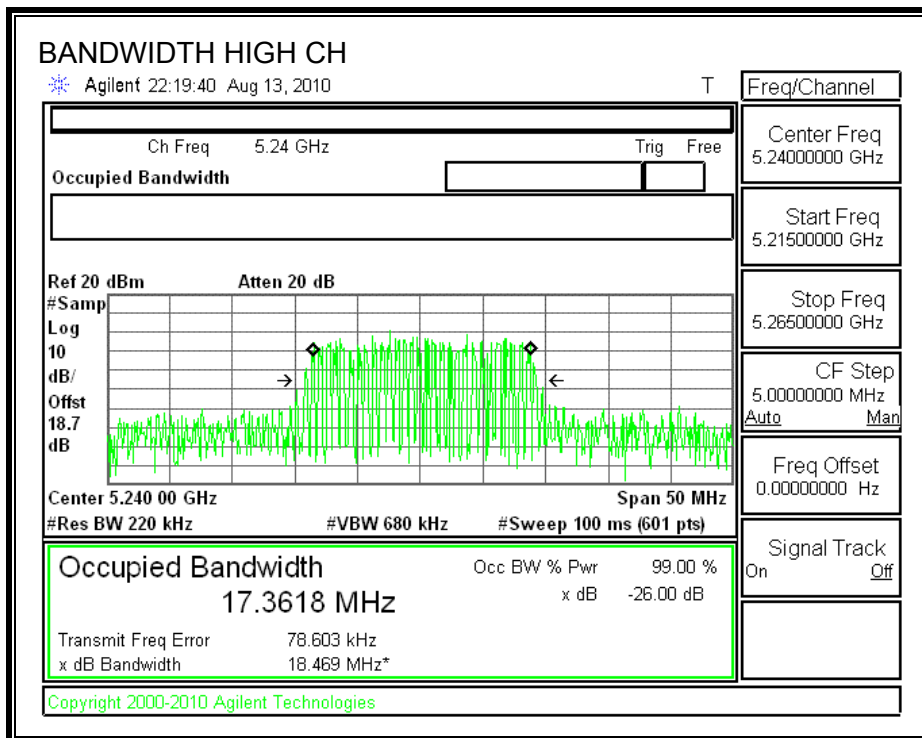
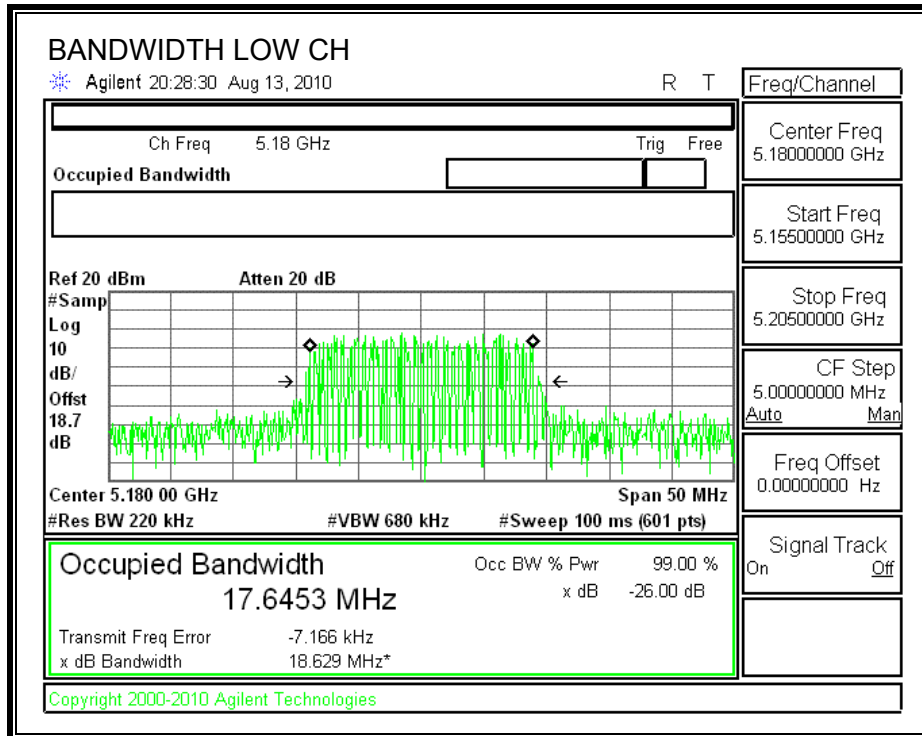

**CHAIN 1**

**26 dB and 99% BANDWIDTH**

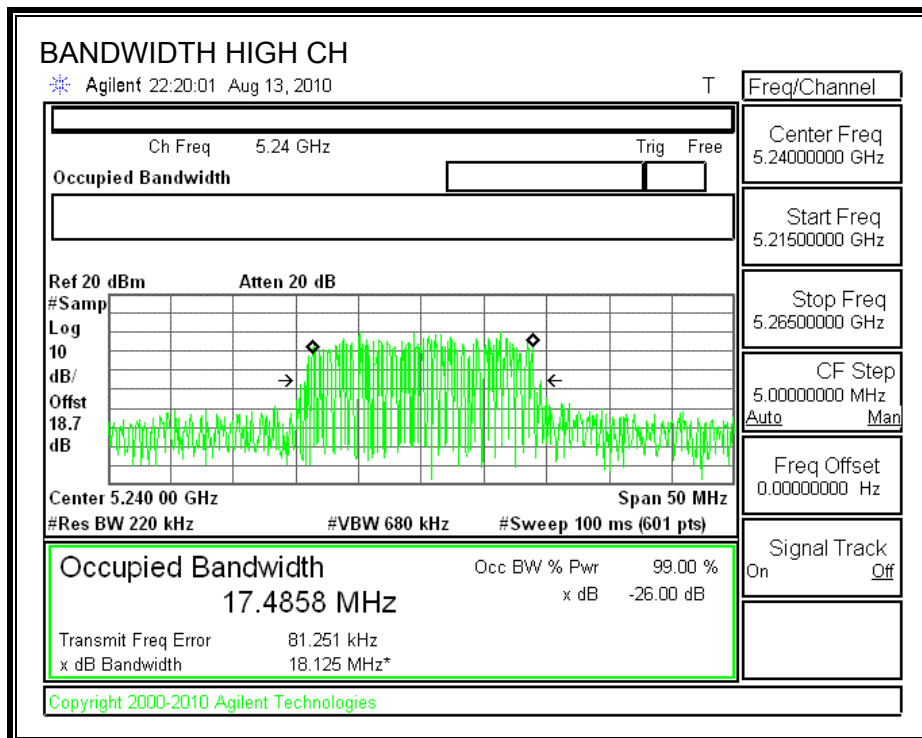
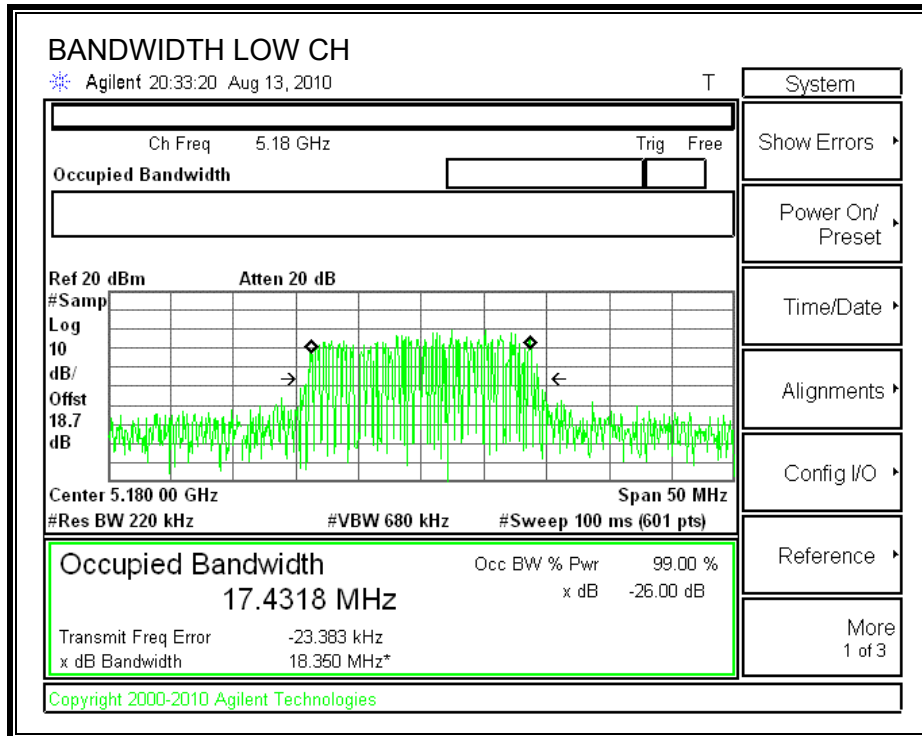

## 7.2.12. OUTPUT POWER

### LIMITS

FCC §15.407 (a) (1)

IC RSS-210 A9.2 (1)

For the 5.15-5.25 GHz band, the maximum conducted output power over the frequency band of operation shall not exceed the lesser of 50 mW or  $4 \text{ dBm} + 10 \log B$ , where B is the 26-dB emission bandwidth in MHz. If transmitting antennas of directional gain greater than 6 dBi are used, both the peak transmit power and the peak power spectral density shall be reduced by the amount in dB that the directional gain of the antenna exceeds 6 dBi.

The composite antenna gain is 5.93 dBi.

### TEST PROCEDURE

The test is performed in accordance with FCC Public Notice: APPENDIX A Guidelines for Assessing Unlicensed National Information Infrastructure (U-NII) Devices – Part 15, Subpart E, August 2002.

The transmitter output operates continuously therefore Method # 1 is used.

**RESULTS**

**Limit**

Channel	Frequency (MHz)	Fixed Limit (dBm)	B (MHz)	4 + 10 Log B Limit (dBm)	Antenna Gain (dBi)	Limit (dBm)
Low	5180	17	18.629	16.70	5.93	16.70
High	5240	17	18.469	16.66	5.93	16.66

**Individual Chain Results**

Channel	Frequency (MHz)	Chain 0 Power (dBm)	Chain 1 Power (dBm)	Total Power (dBm)	Limit (dBm)	Margin (dB)
Low	5180	10.17	9.36	12.79	16.70	-3.91
High	5240	9.55	9.59	12.58	16.66	-4.08



**CHAIN 0 OUTPUT POWER**

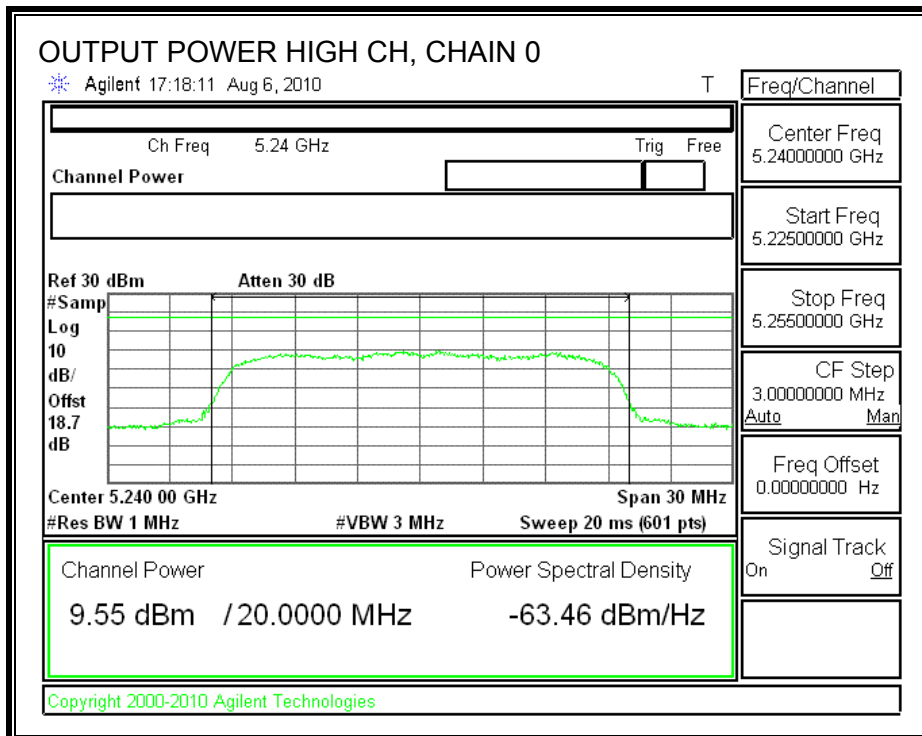
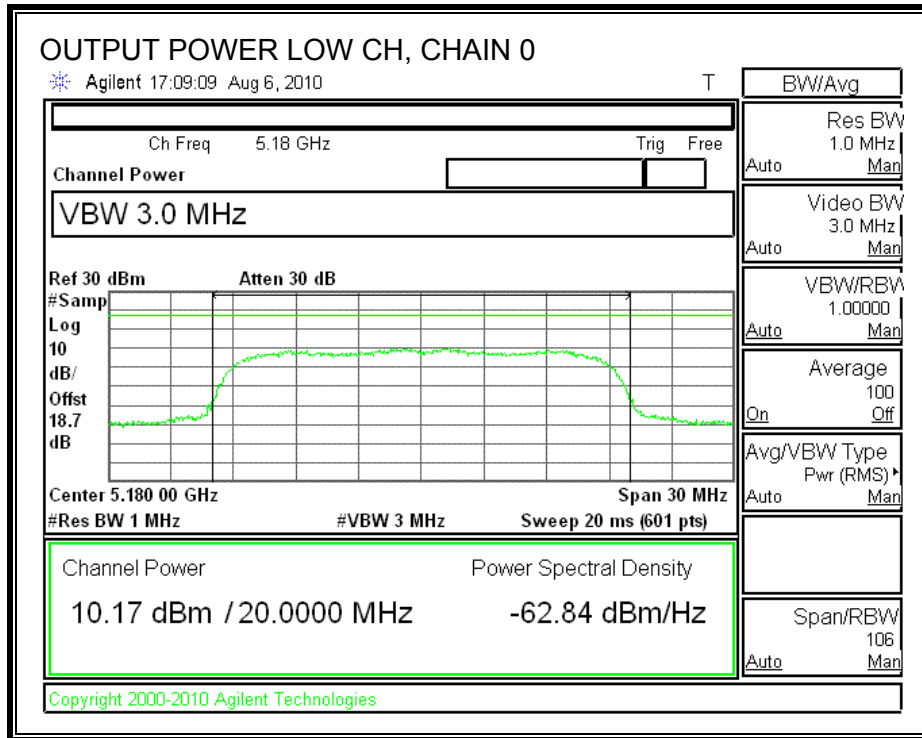

**CHAIN 1 OUTPUT POWER**

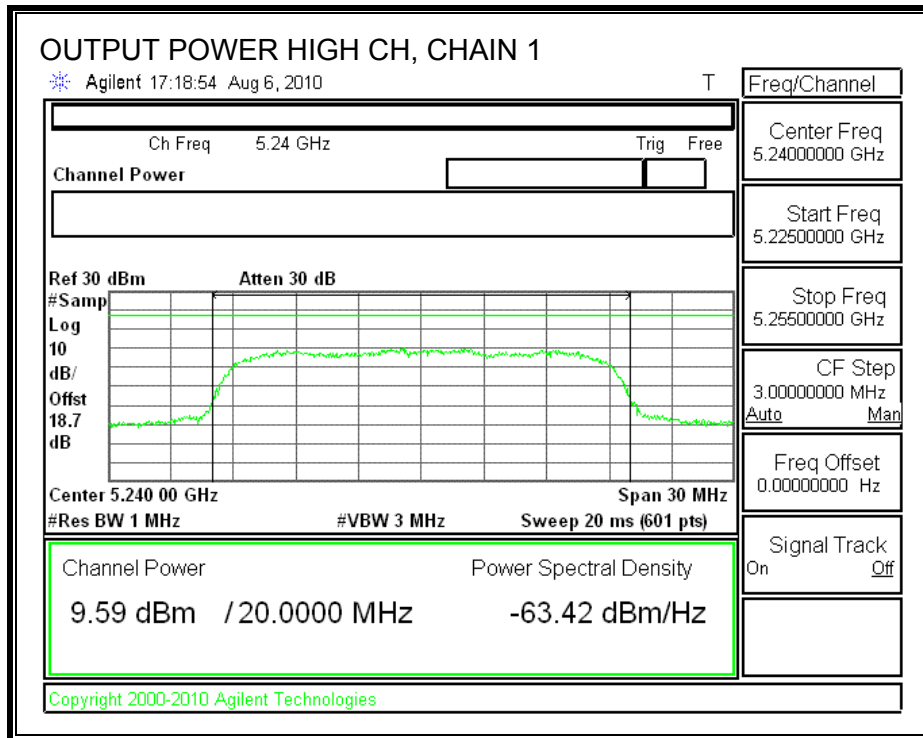
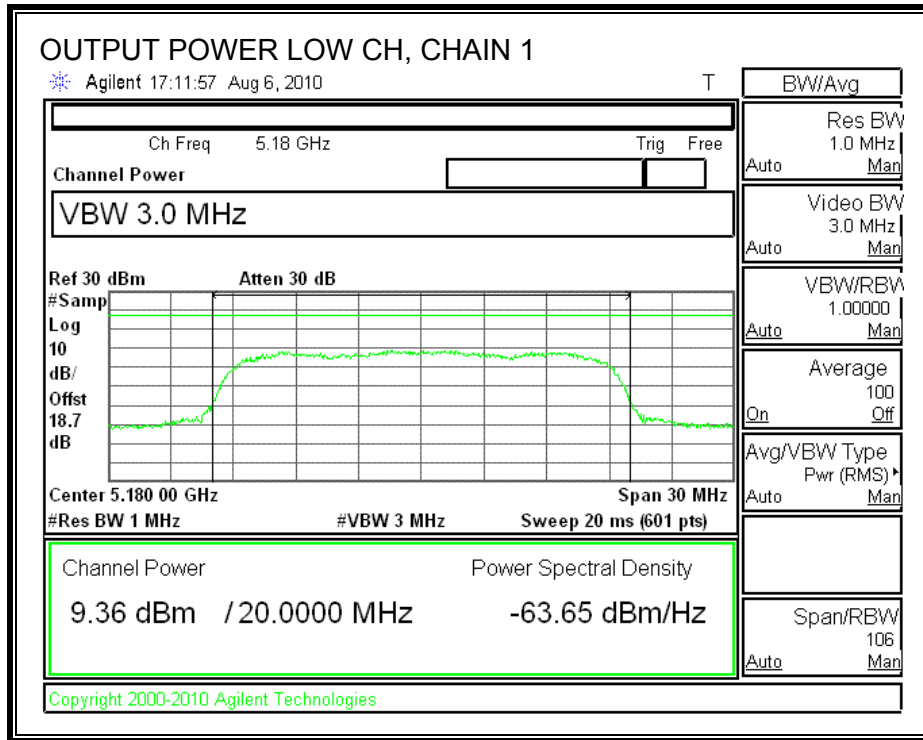

### 7.2.13. PEAK POWER SPECTRAL DENSITY

#### LIMITS

FCC §15.407 (a) (1)

IC RSS-210 A9.2 (1)

For the 5.15-5.25 GHz band, the peak power spectral density shall not exceed 4 dBm in any 1 MHz band. If transmitting antennas of directional gain greater than 6 dBi are used, both the peak transmit power and the peak power spectral density shall be reduced by the amount in dB that the directional gain of the antenna exceeds 6 dBi.

The composite antenna gain is 5.93 dBi, therefore the limit is 4 dBm.

#### TEST PROCEDURE

The test is performed in accordance with FCC Public Notice: APPENDIX A Guidelines for Assessing Unlicensed National Information Infrastructure (U-NII) Devices – Part 15, Subpart E, August 2002. PPSD method #2 was used.

#### RESULTS

Channel	Frequency (MHz)	PPSD With Combiner (dBm)	Limit (dBm)	Margin (dB)
Low	5180	2.676	4.00	-1.32
High	5240	2.430	4.00	-1.57

**POWER SPECTRAL DENSITY WITH COMBINER**

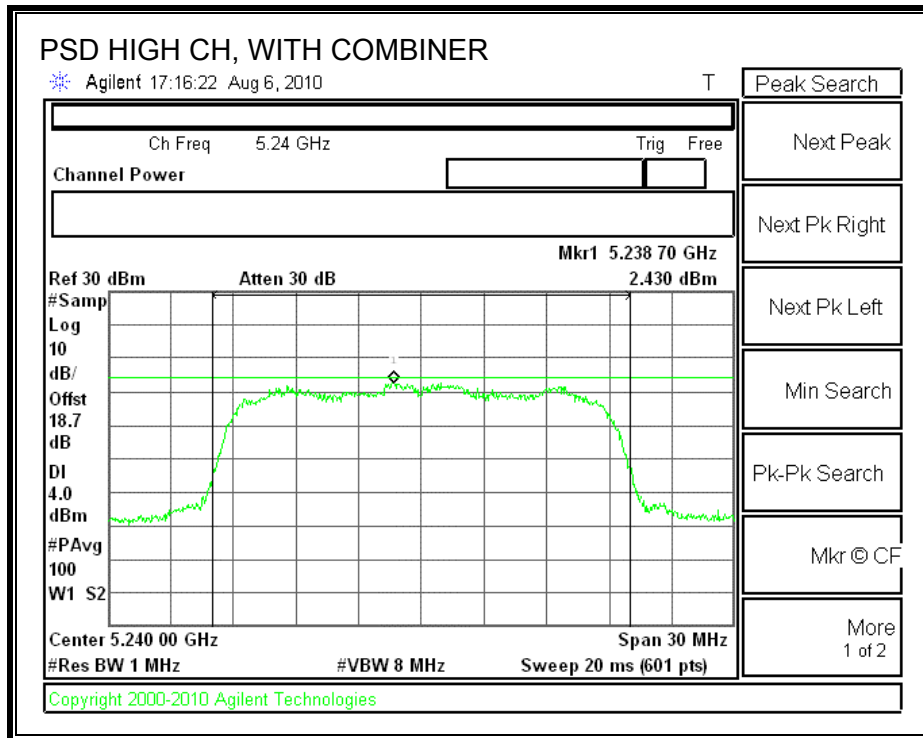
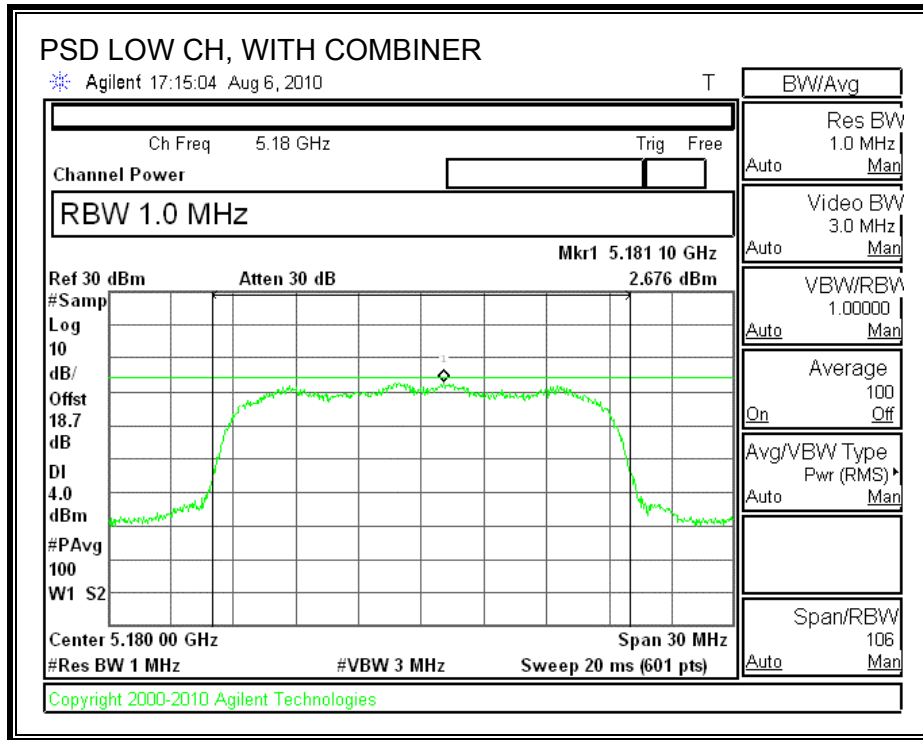

## 7.2.14. PEAK EXCURSION

### LIMITS

FCC §15.407 (a) (6)

The ratio of the peak excursion of the modulation envelope (measured using a peak hold function) to the peak transmit power (measured as specified above) shall not exceed 13 dB across any 1 MHz bandwidth or the emission bandwidth whichever is less.

### TEST PROCEDURE

The transmitter outputs are connected to the spectrum analyzer via a combiner.

The test is performed in accordance with FCC Public Notice: APPENDIX A Guidelines for Assessing Unlicensed National Information Infrastructure (U-NII) Devices – Part 15, Subpart E, August 2002.

Since Method # 1 was used for peak power measurements, Method # 1 settings are used for the second PPSD trace.

### RESULTS

#### CHAIN 0

Channel	Frequency (MHz)	Peak Excursion (dB)	Limit (dB)	Margin (dB)
Low	5180	11.96	13	-1.04
High	5240	9.98	13	-3.02

#### CHAIN 1

Channel	Frequency (MHz)	Peak Excursion (dB)	Limit (dB)	Margin (dB)
Low	5180	11.17	13	-1.83
High	5240	11.64	13	-1.36

**CHAIN 0**

**PEAK EXCURSION**

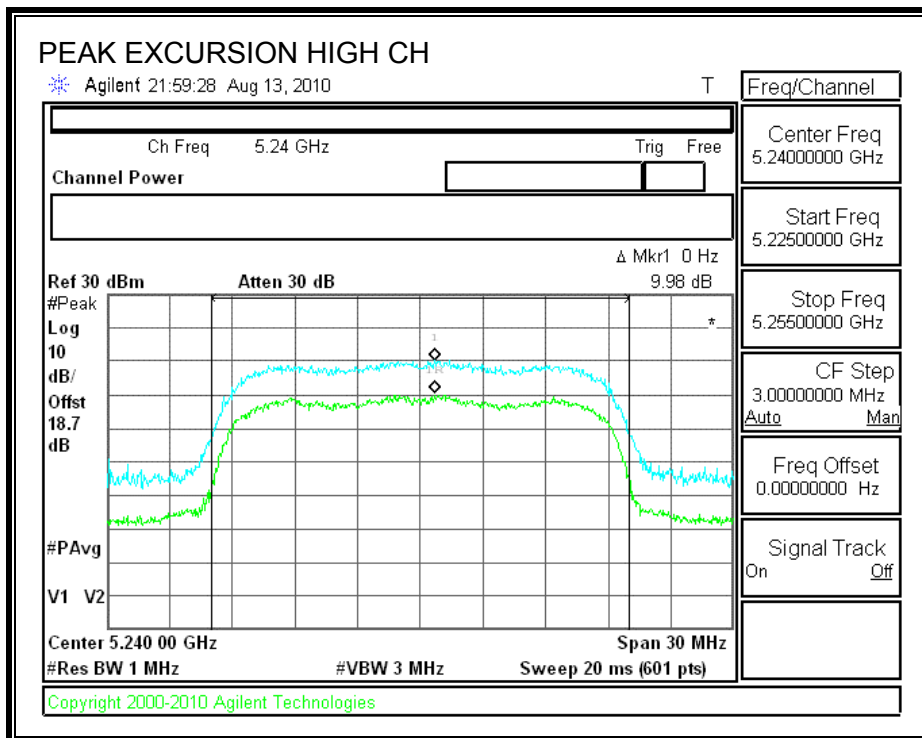
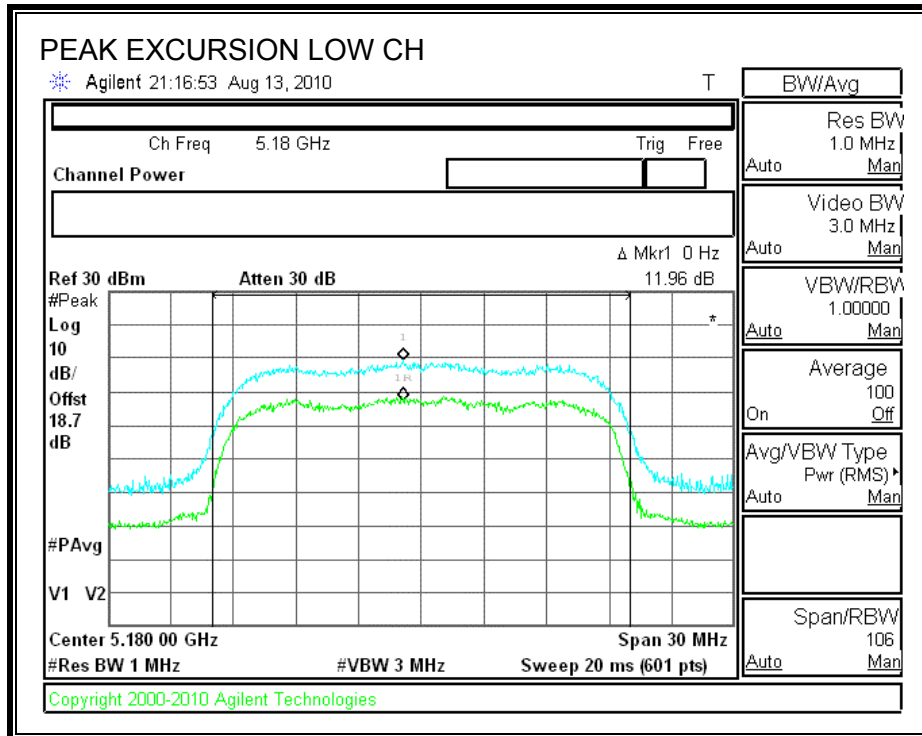

**CHAIN 1**

**PEAK EXCURSION**

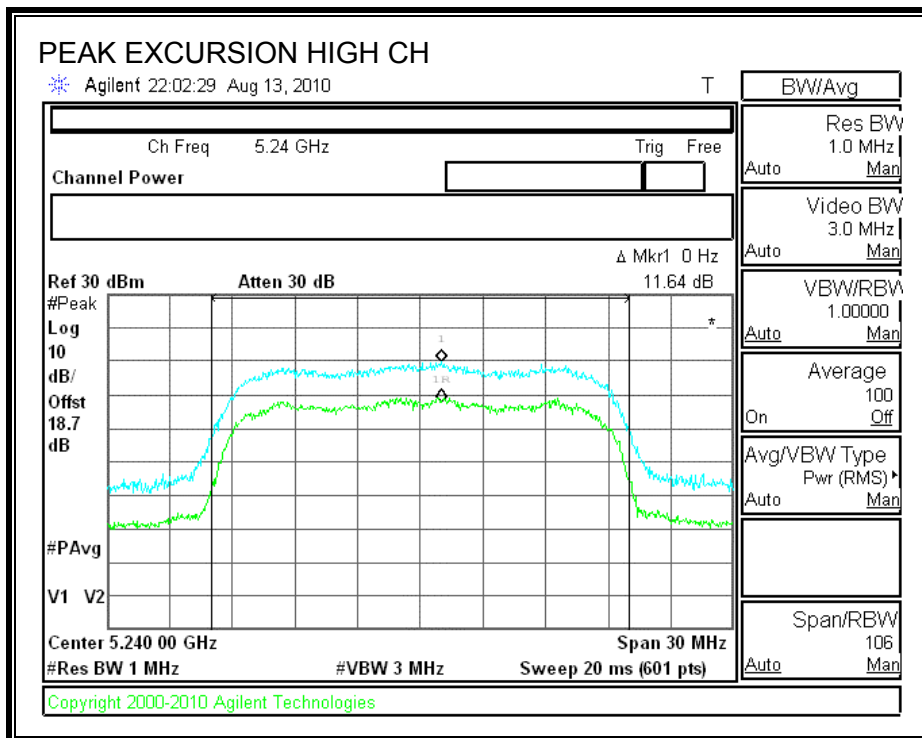
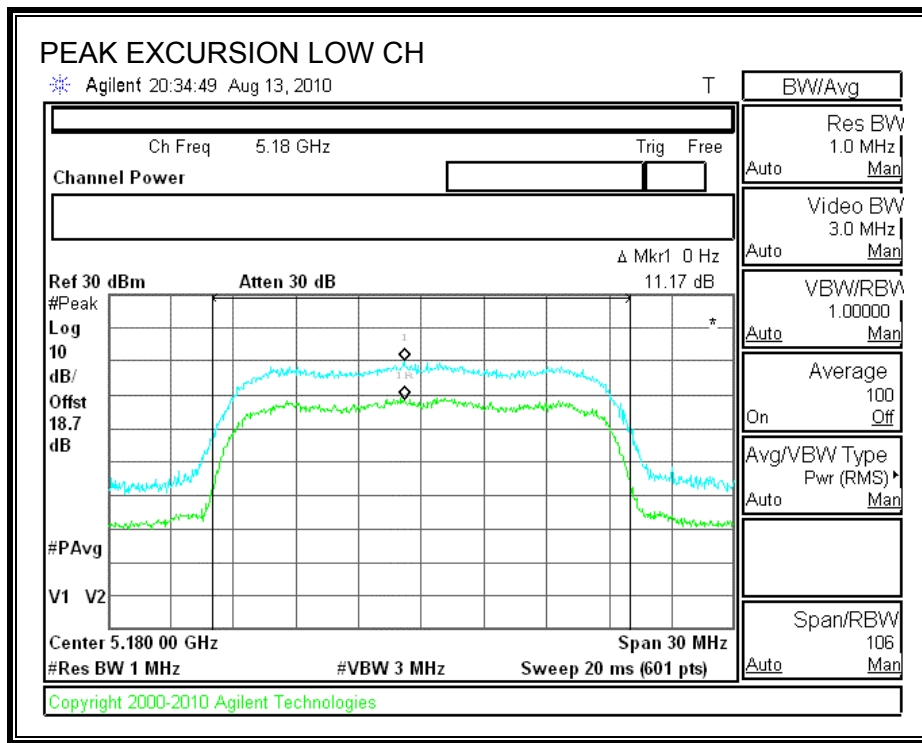

## **7.2.15. CONDUCTED SPURIOUS EMISSIONS**

### **LIMITS**

FCC §15.407 (b) (1)

IC RSS-210 A9.3 (1)

For transmitters operating in the 5.15-5.25 GHz band: all emissions outside of the 5.15-5.35 GHz band shall not exceed an EIRP of -27 dBm / MHz.

### **TEST PROCEDURE**

Conducted RF measurements of the transmitter output are made to confirm that the EUT antenna port conducted emissions meet the specified limit and to identify any spurious signals that require further investigation or measurements on the radiated emissions site.

The transmitter output is connected to the spectrum analyzer. The resolution bandwidth is set to 1 MHz. The video bandwidth is set to 1 MHz. Peak detection measurements are compared to EIRP limit, adjusted for the maximum antenna gain.

Measurements are made over the 30 MHz to 40 GHz range with the transmitter set to the lowest, middle, and highest channels.



**SPURIOUS EMISSIONS**

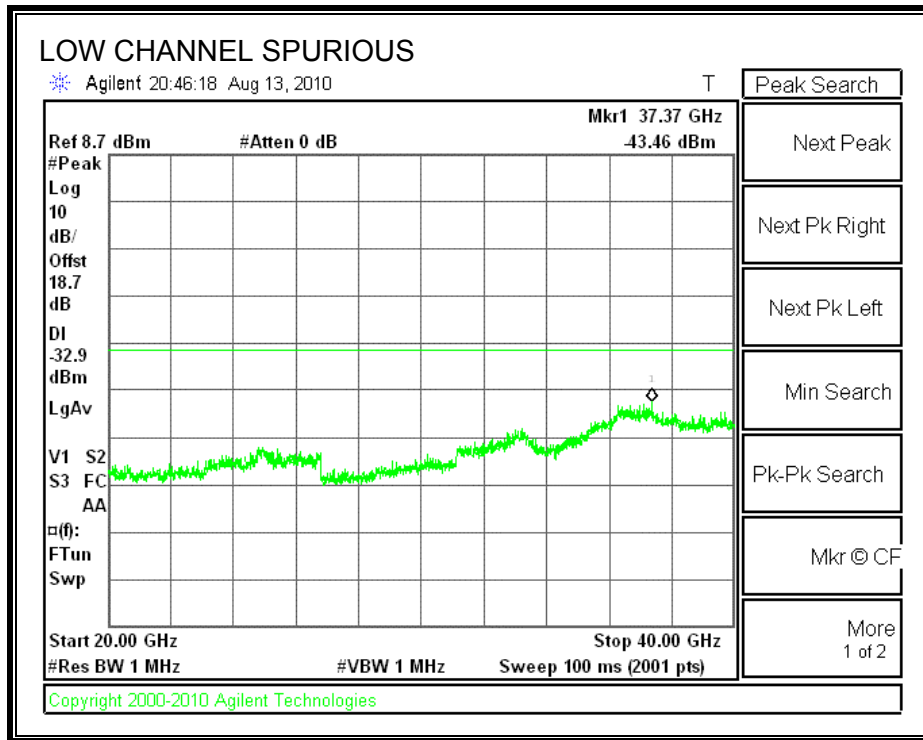
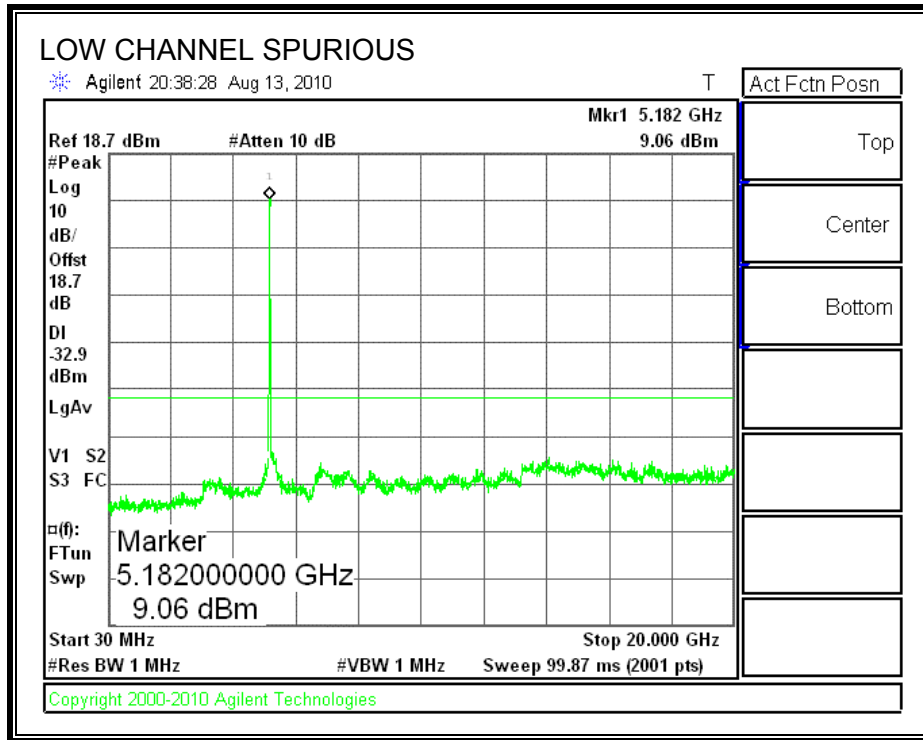

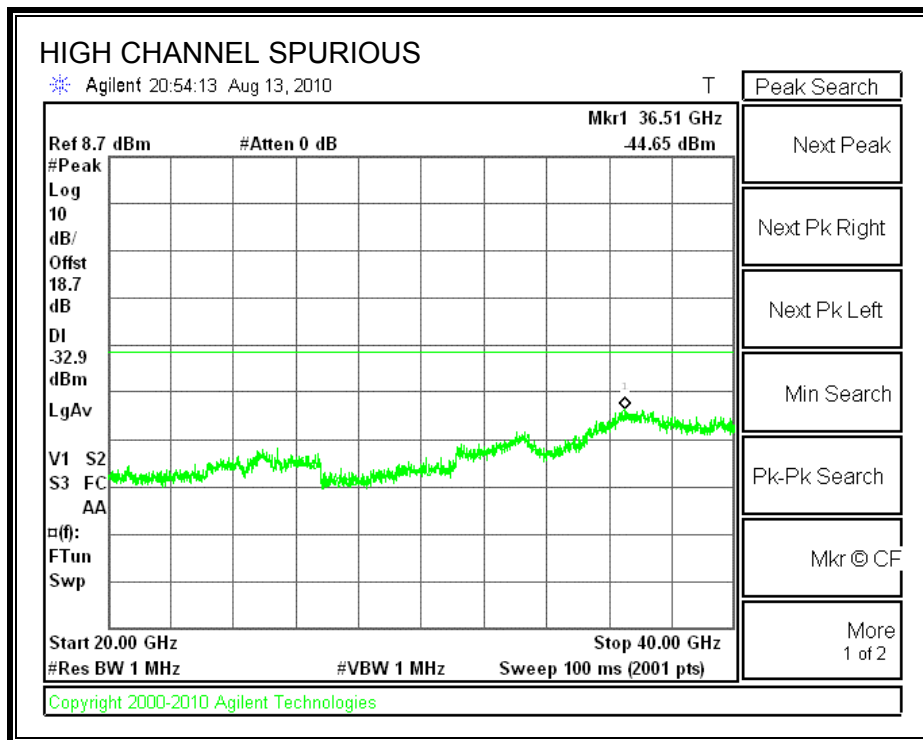
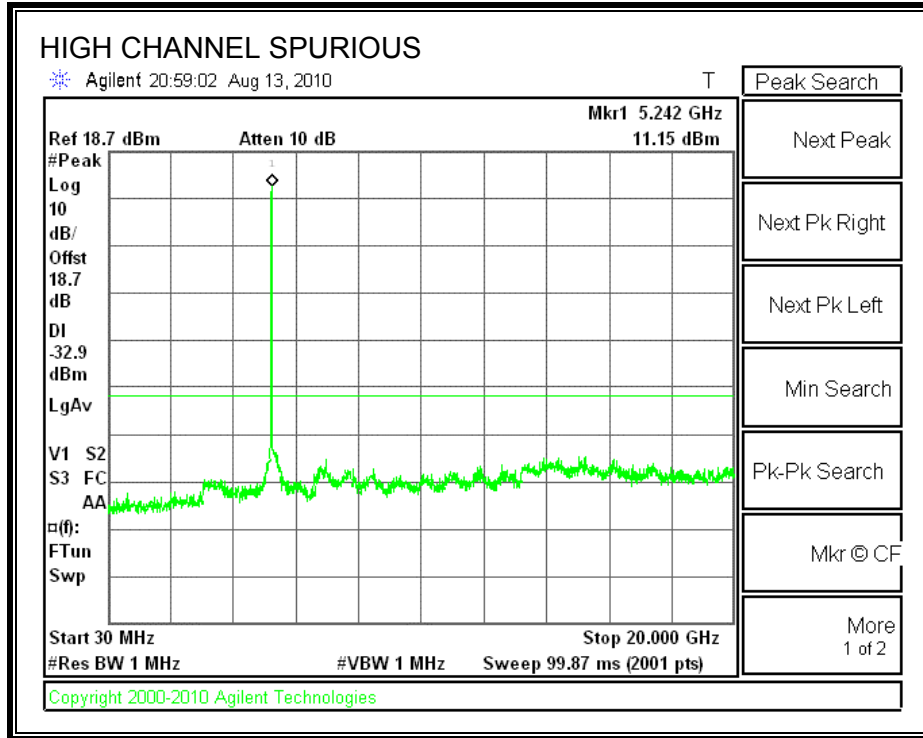

### 7.3. 802.11n HT40 SISO MODE IN THE 5.2 GHz BAND

#### 7.3.1. 26 dB and 99% BANDWIDTH

##### LIMITS

None; for reporting purposes only.

##### TEST PROCEDURE

The transmitter outputs are connected to the spectrum analyzer via a combiner. The RBW is set to 1% to 3% of the measured bandwidth. The VBW is set to 3 times the RBW. The sweep time is coupled. The spectrum analyzer internal bandwidth function is utilized.

##### RESULTS

Channel	Frequency (MHz)	26 dB Bandwidth (MHz)	99% Bandwidth (MHz)
Low	5190	38.5110	36.0311
High	5230	38.3960	36.2250

**26 dB and 99% BANDWIDTH**

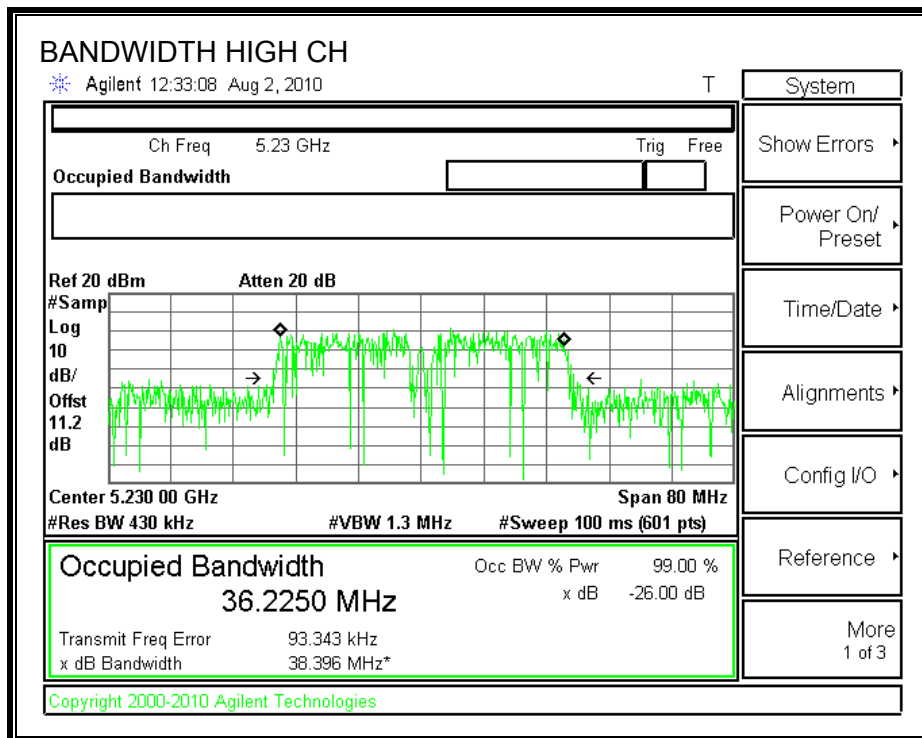
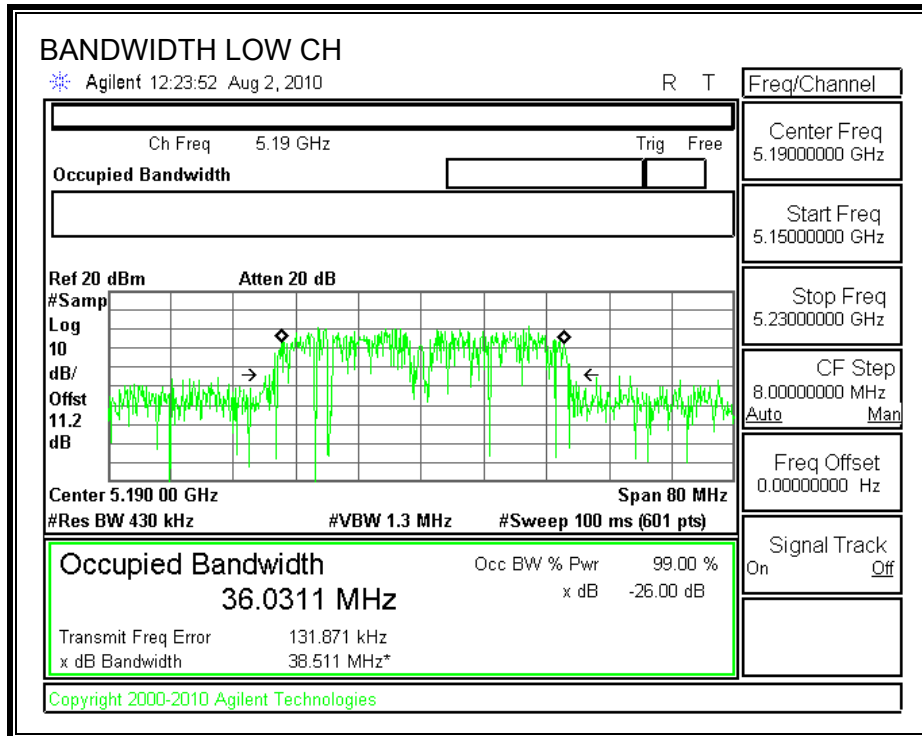

### 7.3.2. OUTPUT POWER

#### LIMITS

FCC §15.407 (a) (1)

IC RSS-210 A9.2 (1)

For the 5.15-5.25 GHz band, the maximum conducted output power over the frequency band of operation shall not exceed the lesser of 50 mW or  $4 \text{ dBm} + 10 \log B$ , where B is the 26-dB emission bandwidth in MHz. If transmitting antennas of directional gain greater than 6 dBi are used, both the peak transmit power and the peak power spectral density shall be reduced by the amount in dB that the directional gain of the antenna exceeds 6 dBi.

The maximum antenna gain is 5.93 dBi.

#### TEST PROCEDURE

The test is performed in accordance with FCC Public Notice: APPENDIX A Guidelines for Assessing Unlicensed National Information Infrastructure (U-NII) Devices – Part 15, Subpart E, August 2002.

The transmitter output operates continuously therefore Method # 1 is used.

#### RESULTS

##### Limit

Channel	Frequency (MHz)	Fixed Limit (dBm)	B (MHz)	4 + 10 Log B Limit (dBm)	Antenna Gain (dBi)	Limit (dBm)
Low	5190	17	38.511	19.86	5.93	17.00
High	5230	17	38.396	19.84	5.93	17.00

##### Results

Channel	Frequency (MHz)	Power (dBm)	Limit (dBm)	Margin (dB)
Low	5190	15.02	17.00	-1.98
High	5230	16.20	17.00	-0.80

**OUTPUT POWER**

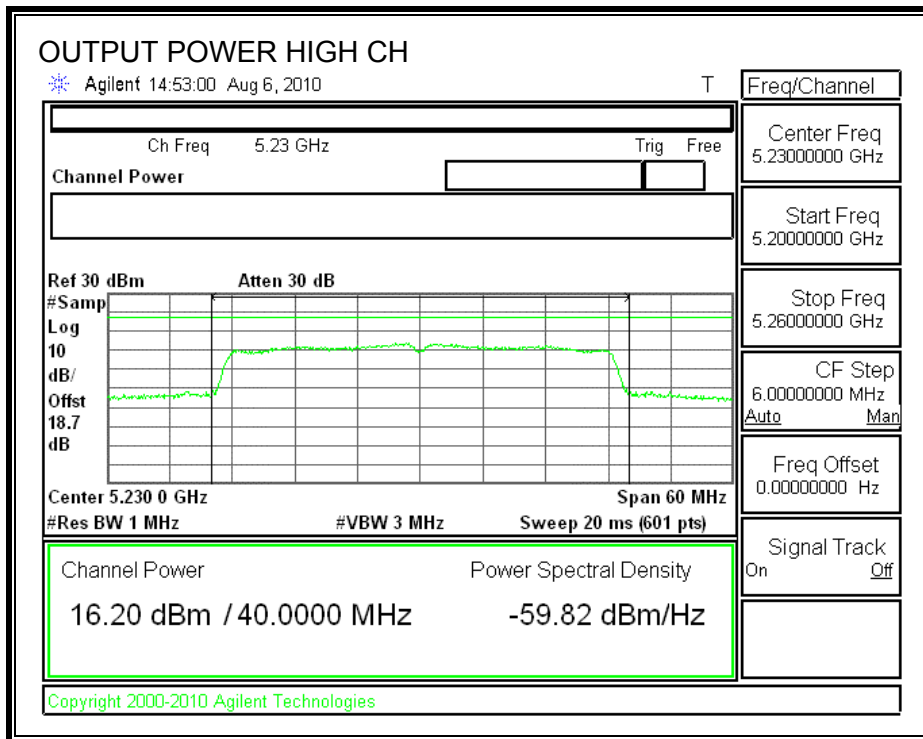
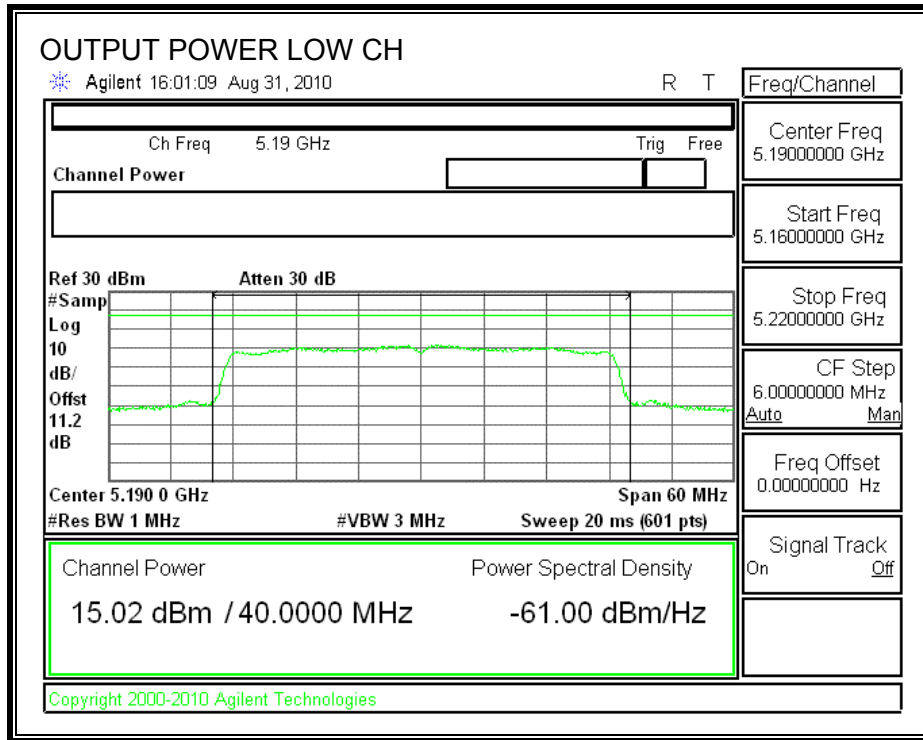

### 7.3.3. PEAK POWER SPECTRAL DENSITY

#### LIMITS

FCC §15.407 (a) (1)

IC RSS-210 A9.2 (1)

For the 5.15-5.25 GHz band, the peak power spectral density shall not exceed 4 dBm in any 1 MHz band. If transmitting antennas of directional gain greater than 6 dBi are used, both the peak transmit power and the peak power spectral density shall be reduced by the amount in dB that the directional gain of the antenna exceeds 6 dBi.

The composite antenna gain is 5.93 dBi, therefore the limit is 4 dBm.

#### TEST PROCEDURE

The test is performed in accordance with FCC Public Notice: APPENDIX A Guidelines for Assessing Unlicensed National Information Infrastructure (U-NII) Devices – Part 15, Subpart E, August 2002. PPSD method #2 was used.

#### RESULTS

Channel	Frequency (MHz)	PPSD (dBm)	Limit (dBm)	Margin (dB)
Low	5190	1.53	4.00	-2.47
High	5230	3.21	4.00	-0.79

**POWER SPECTRAL DENSITY**

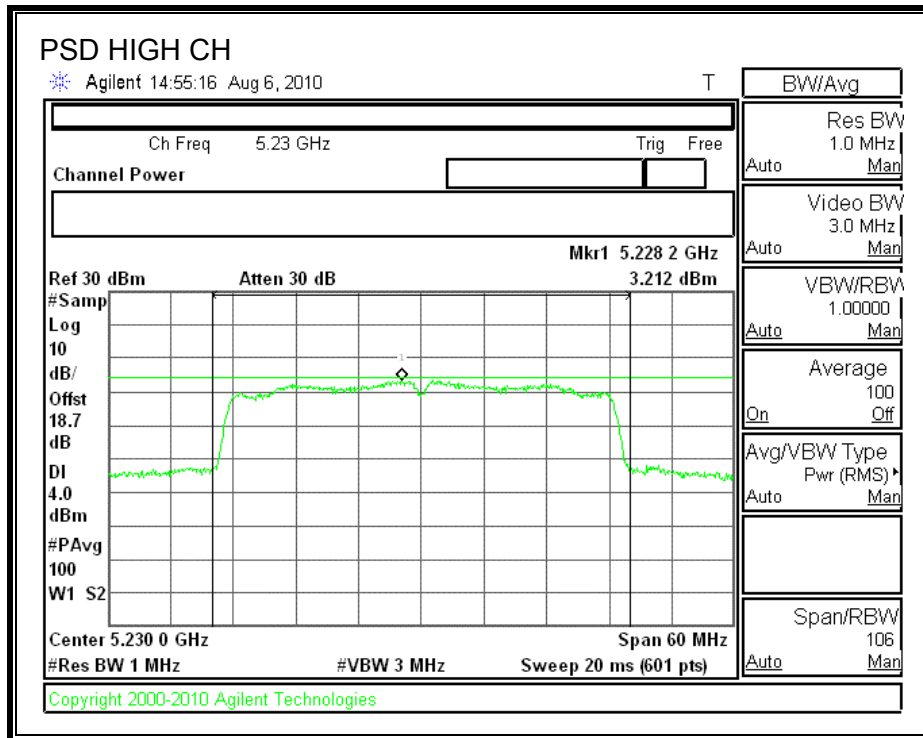
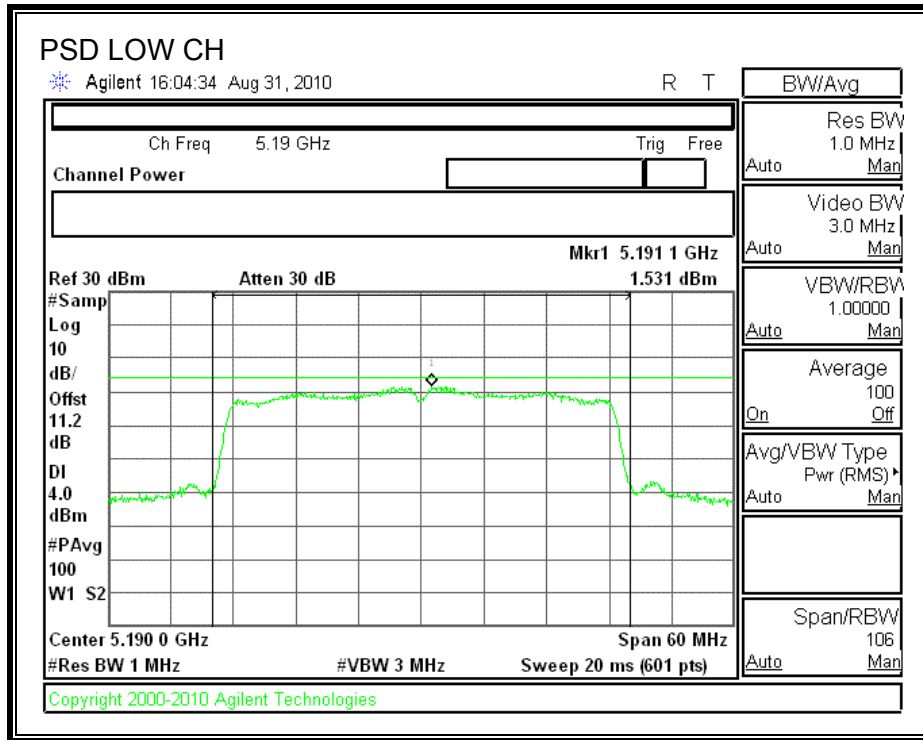



### 7.3.4. PEAK EXCURSION

#### LIMITS

FCC §15.407 (a) (6)

The ratio of the peak excursion of the modulation envelope (measured using a peak hold function) to the peak transmit power (measured as specified above) shall not exceed 13 dB across any 1 MHz bandwidth or the emission bandwidth whichever is less.

#### TEST PROCEDURE

The transmitter outputs are connected to the spectrum analyzer via a combiner.

The test is performed in accordance with FCC Public Notice: APPENDIX A Guidelines for Assessing Unlicensed National Information Infrastructure (U-NII) Devices – Part 15, Subpart E, August 2002.

Since Method # 1 was used for peak power measurements, Method # 1 settings are used for the second PPSD trace.

#### RESULTS

Channel	Frequency (MHz)	Peak Excursion (dB)	Limit (dB)	Margin (dB)
Low	5190	9.58	13	-3.42
High	5230	9.00	13	-4.00

**PEAK EXCURSION**

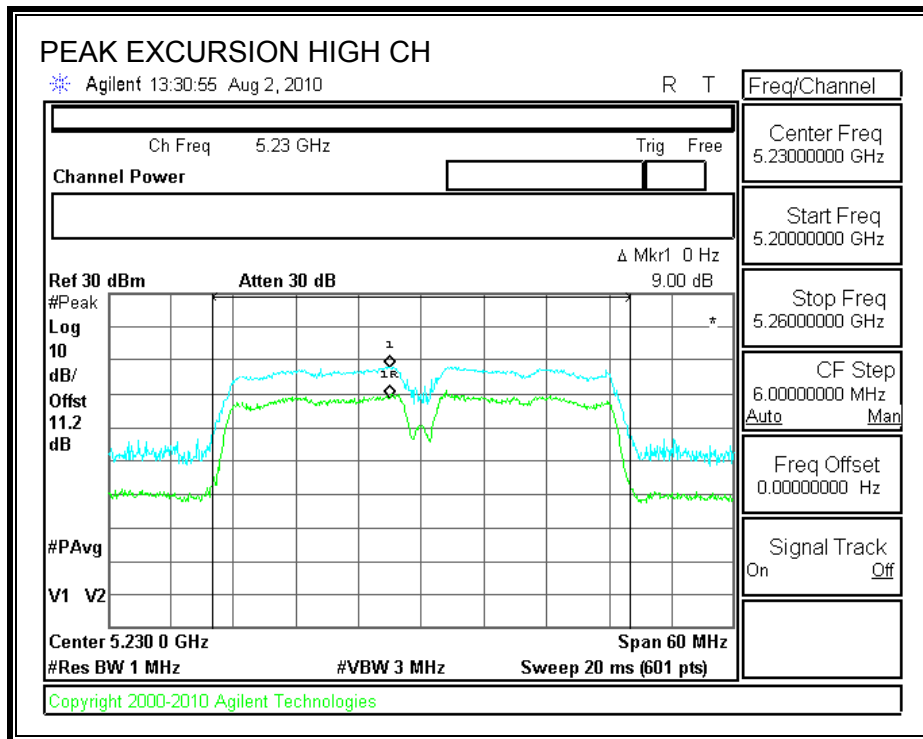
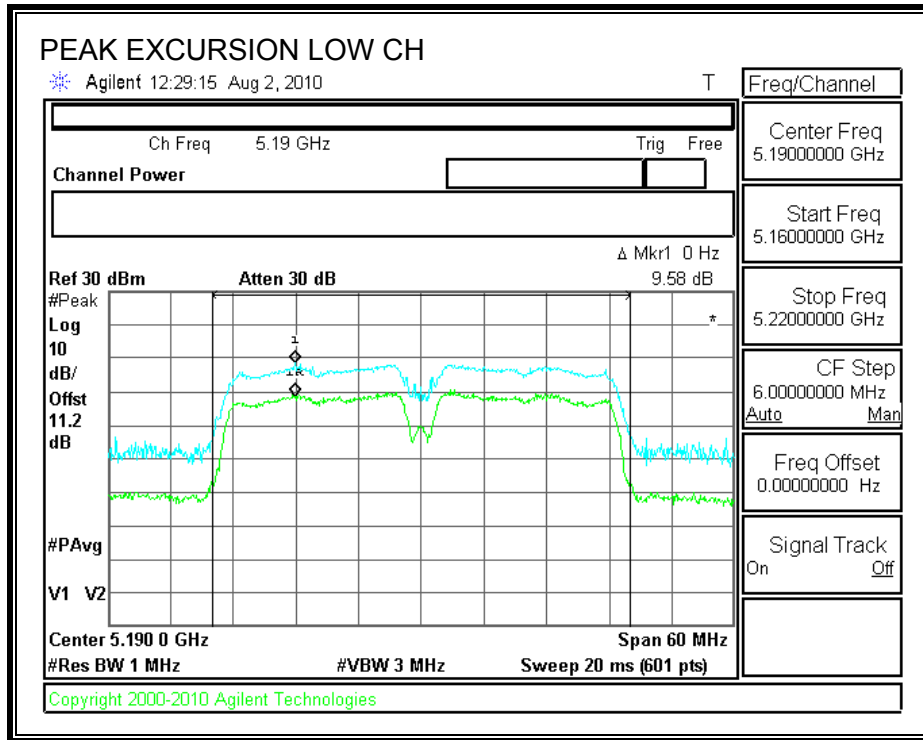

### **7.3.5. CONDUCTED SPURIOUS EMISSIONS**

#### **LIMITS**

FCC §15.407 (b) (1)

IC RSS-210 A9.3 (1)

For transmitters operating in the 5.15-5.25 GHz band: all emissions outside of the 5.15-5.35 GHz band shall not exceed an EIRP of -27 dBm / MHz.

#### **TEST PROCEDURE**

Conducted RF measurements of the transmitter output are made to confirm that the EUT antenna port conducted emissions meet the specified limit and to identify any spurious signals that require further investigation or measurements on the radiated emissions site.

The transmitter output is connected to the spectrum analyzer. The resolution bandwidth is set to 1 MHz. The video bandwidth is set to 1MHz. Peak detection measurements are compared to EIRP limit, adjusted for the maximum antenna gain.

Measurements are made over the 30 MHz to 40 GHz range with the transmitter set to the lowest, middle, and highest channels.

**SPURIOUS EMISSIONS**

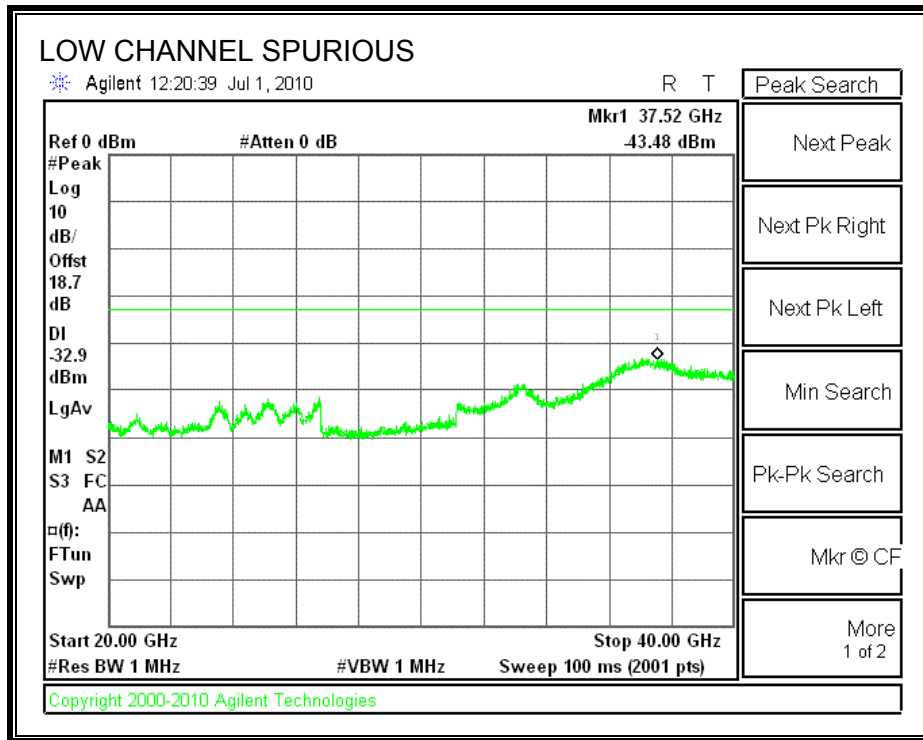
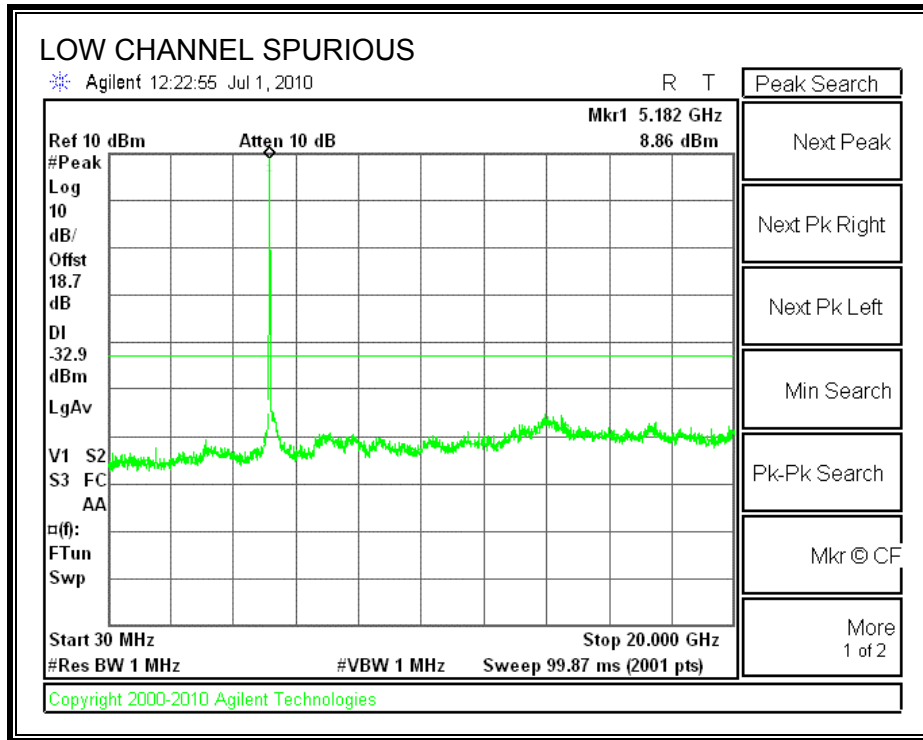



## 7.4. 802.11n HT40 MODE IN THE 5.2 GHz BAND

### HT40 MCS8 SDM – Non-Coherent

#### 7.4.1. 26 dB and 99% BANDWIDTH

##### LIMITS

None; for reporting purposes only.

##### TEST PROCEDURE

The transmitter outputs are connected to the spectrum analyzer via a combiner. The RBW is set to 1% to 3% of the measured bandwidth. The VBW is set to 3 times the RBW. The sweep time is coupled. The spectrum analyzer internal bandwidth function is utilized.

##### RESULTS

###### CHAIN 0

Channel	Frequency (MHz)	26 dB Bandwidth (MHz)	99% Bandwidth (MHz)
Low	5190	38.258	35.7082
High	5230	38.298	35.8896

###### CHAIN 1

Channel	Frequency (MHz)	26 dB Bandwidth (MHz)	99% Bandwidth (MHz)
Low	5190	37.467	36.2211
High	5230	38.684	35.773

**CHAIN 0**

**26 dB and 99% BANDWIDTH**

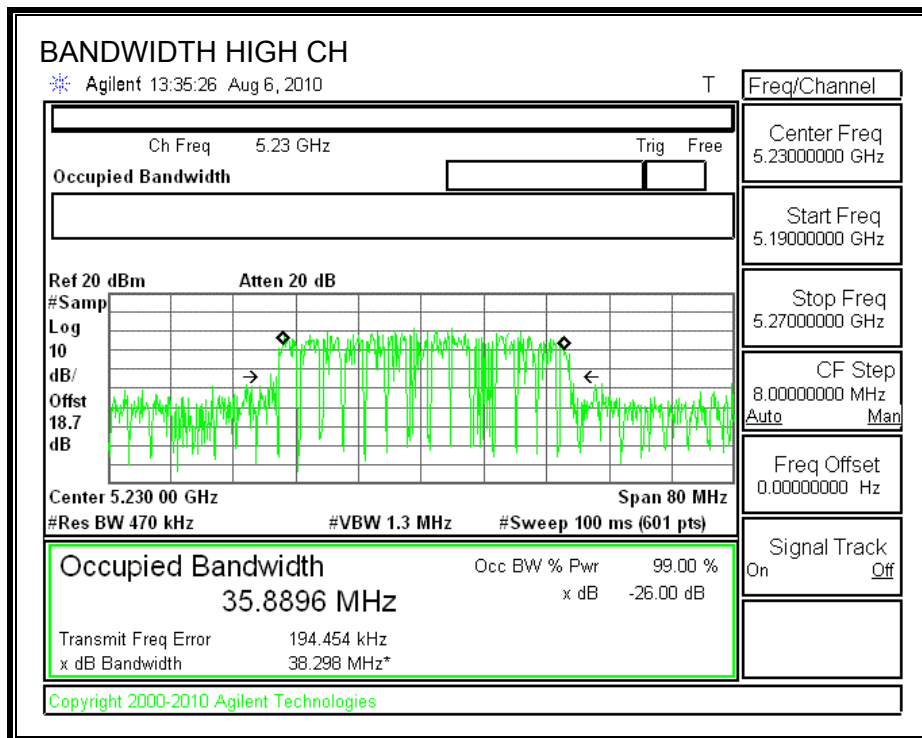
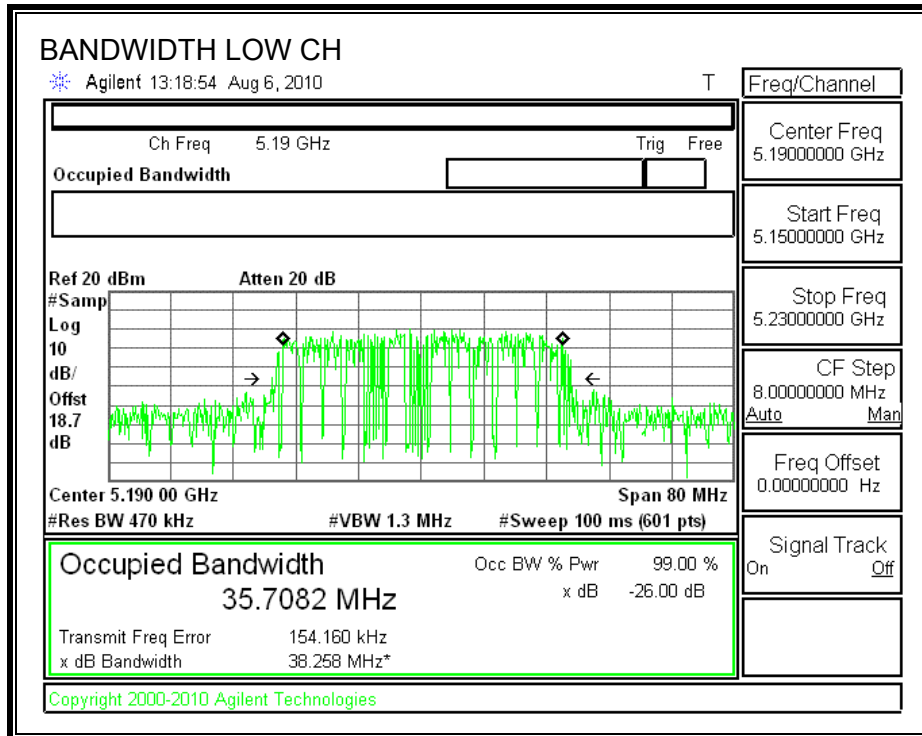

**CHAIN 1**

**26 dB and 99% BANDWIDTH**

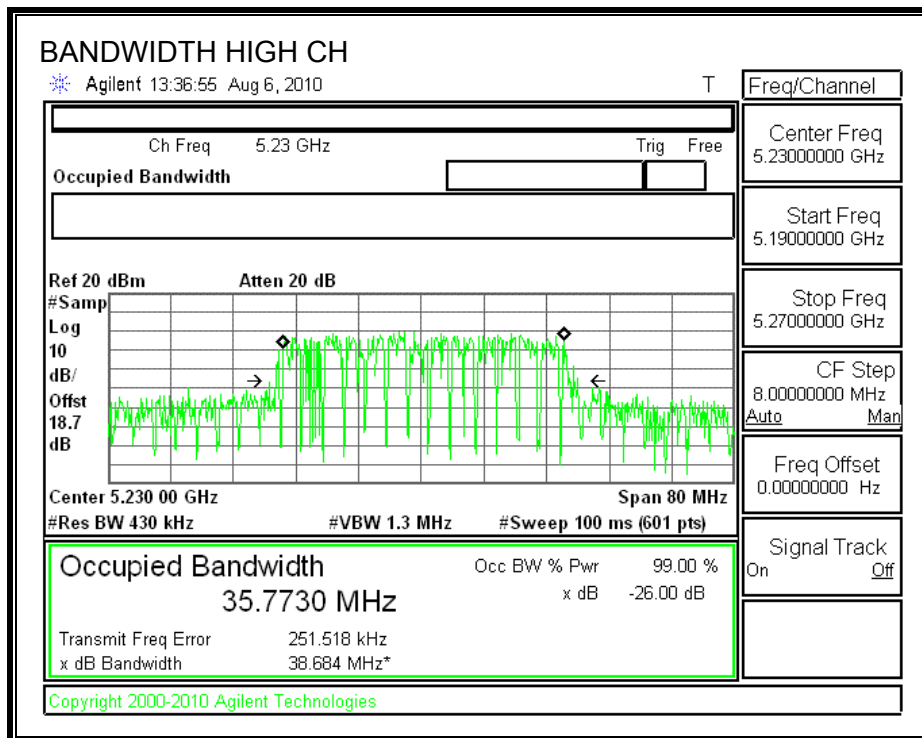
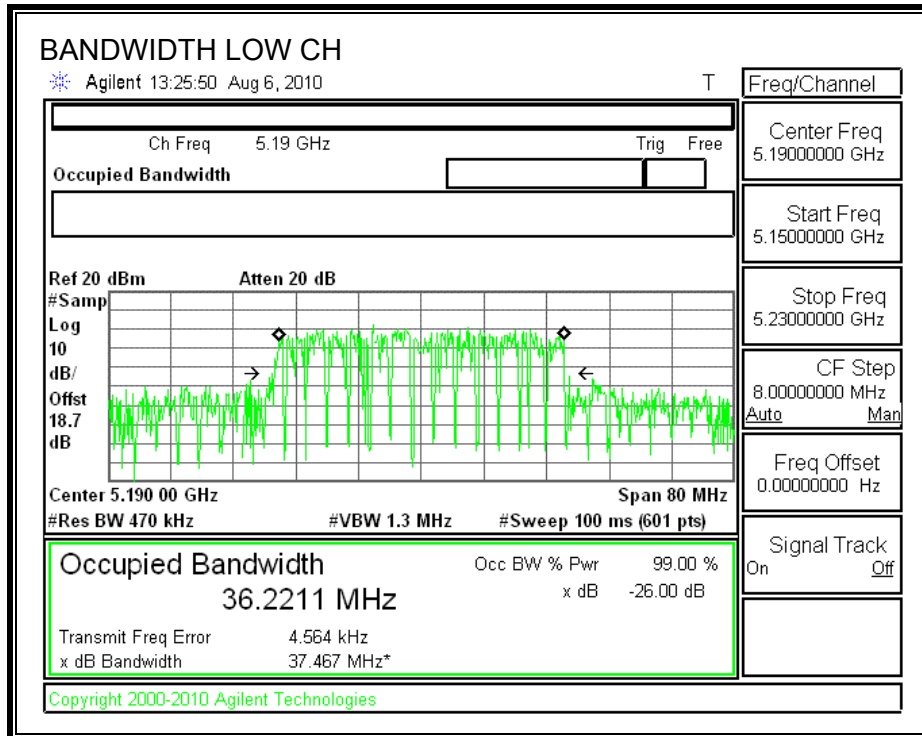



## 7.4.2. OUTPUT POWER

### LIMITS

FCC §15.407 (a) (1)

IC RSS-210 A9.2 (1)

For the 5.15-5.25 GHz band, the maximum conducted output power over the frequency band of operation shall not exceed the lesser of 50 mW or  $4 \text{ dBm} + 10 \log B$ , where B is the 26-dB emission bandwidth in MHz. If transmitting antennas of directional gain greater than 6 dBi are used, both the peak transmit power and the peak power spectral density shall be reduced by the amount in dB that the directional gain of the antenna exceeds 6 dBi.

The composite antenna gain is 5.93 dBi.

### TEST PROCEDURE

The test is performed in accordance with FCC Public Notice: APPENDIX A Guidelines for Assessing Unlicensed National Information Infrastructure (U-NII) Devices – Part 15, Subpart E, August 2002.

The transmitter output operates continuously therefore Method # 1 is used.

### RESULTS

#### Limit

Channel	Frequency (MHz)	Fixed Limit (dBm)	B (MHz)	4 + 10 Log B Limit (dBm)	Antenna Gain (dBi)	Limit (dBm)
Low	5190	17	37.467	19.74	5.93	17.00
High	5230	17	38.684	19.88	5.93	17.00

#### Individual Chain Results

Channel	Frequency (MHz)	Chain 0 Power (dBm)	Chain 1 Power (dBm)	Total Power (dBm)	Limit (dBm)	Margin (dB)
Low	5190	11.24	12.80	15.10	17.00	-1.90
High	5230	12.14	12.08	15.12	17.00	-1.88

**CHAIN 0 OUTPUT POWER**

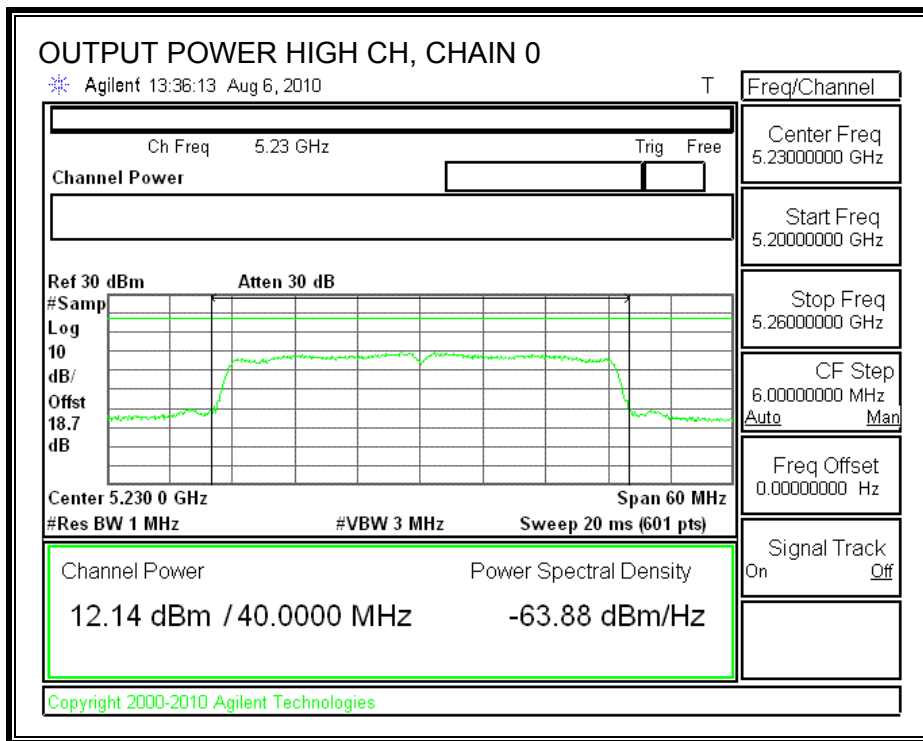
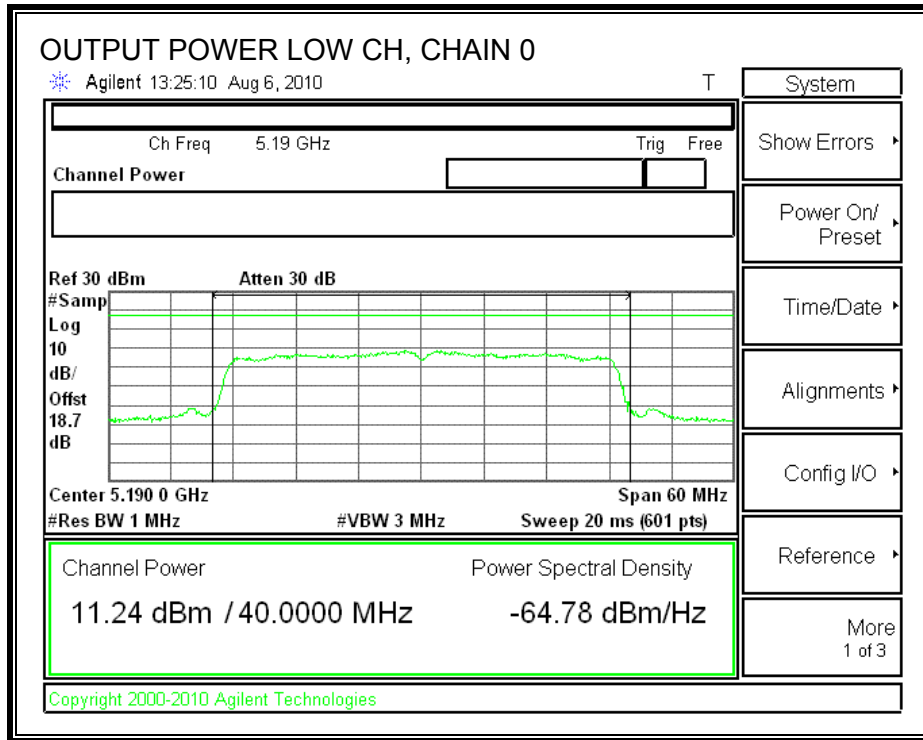

**CHAIN 1 OUTPUT POWER**

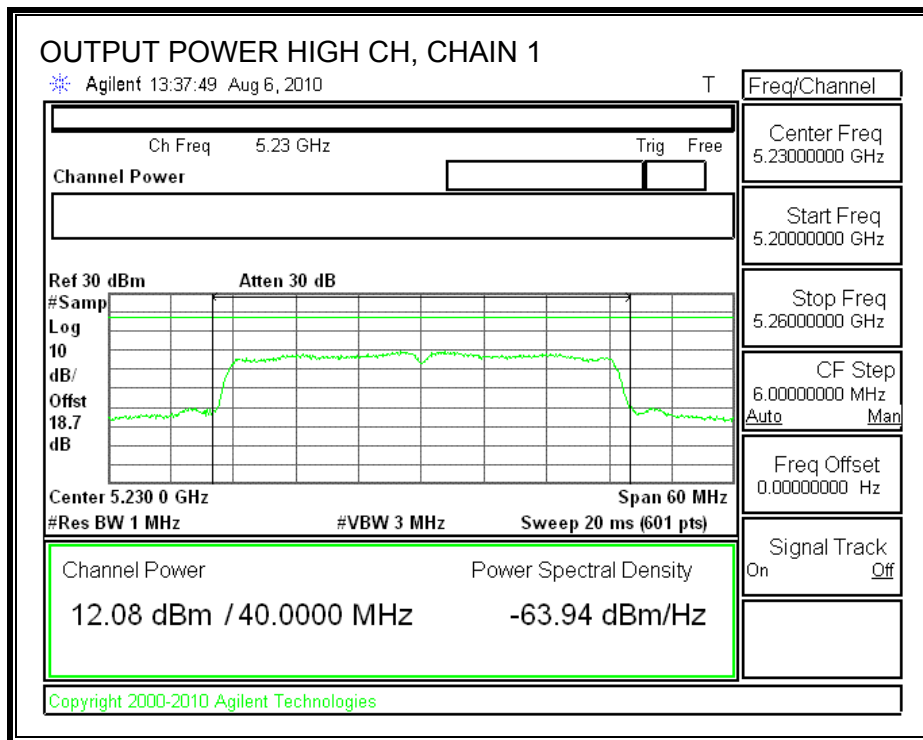
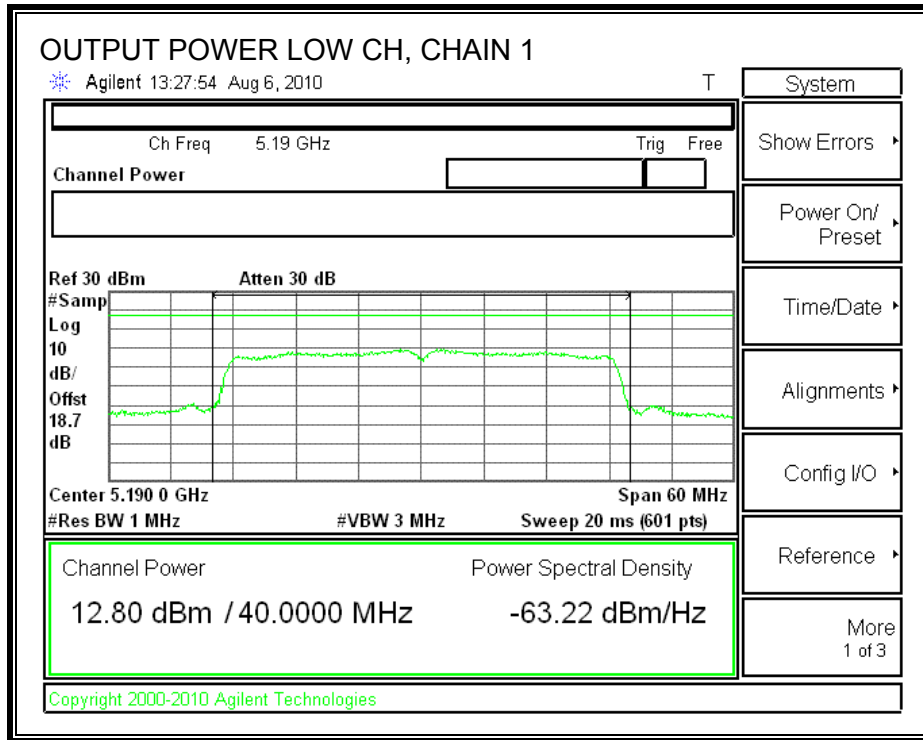

### 7.4.3. PEAK POWER SPECTRAL DENSITY

#### LIMITS

FCC §15.407 (a) (1)

IC RSS-210 A9.2 (1)

For the 5.15-5.25 GHz band, the peak power spectral density shall not exceed 4 dBm in any 1 MHz band. If transmitting antennas of directional gain greater than 6 dBi are used, both the peak transmit power and the peak power spectral density shall be reduced by the amount in dB that the directional gain of the antenna exceeds 6 dBi.

The maximum antenna gain is 5.93 dBi, therefore the limit is 4 dBm.

#### TEST PROCEDURE

The test is performed in accordance with FCC Public Notice: APPENDIX A Guidelines for Assessing Unlicensed National Information Infrastructure (U-NII) Devices – Part 15, Subpart E, August 2002. PPSD method #2 was used.

#### RESULTS

Channel	Frequency (MHz)	PPSD With Combiner (dBm)	Limit (dBm)	Margin (dB)
Low	5190	1.97	4.00	-2.03
High	5230	1.70	4.00	-2.30

**POWER SPECTRAL DENSITY**

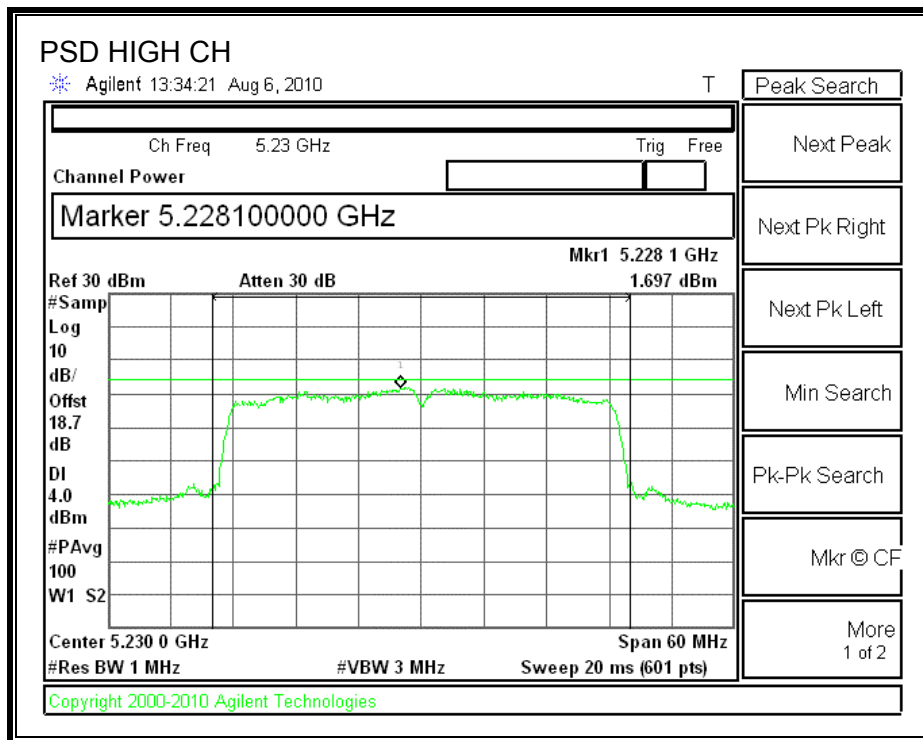
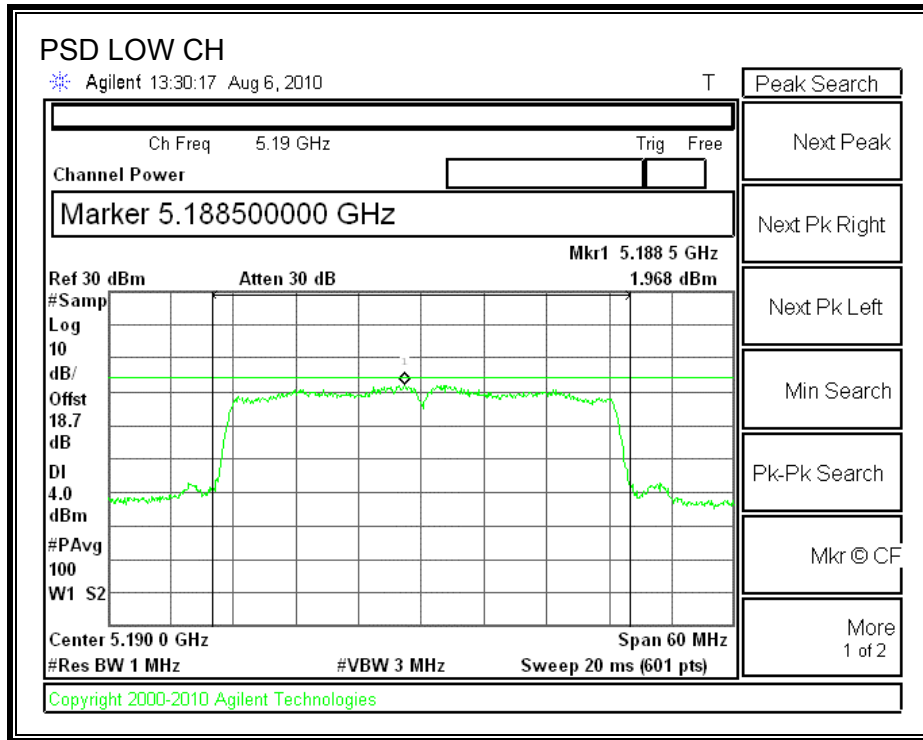

### 7.4.4. PEAK EXCURSION

#### LIMITS

FCC §15.407 (a) (6)

The ratio of the peak excursion of the modulation envelope (measured using a peak hold function) to the peak transmit power (measured as specified above) shall not exceed 13 dB across any 1 MHz bandwidth or the emission bandwidth whichever is less.

#### TEST PROCEDURE

The transmitter outputs are connected to the spectrum analyzer via a combiner.

The test is performed in accordance with FCC Public Notice: APPENDIX A Guidelines for Assessing Unlicensed National Information Infrastructure (U-NII) Devices – Part 15, Subpart E, August 2002.

Since Method # 1 was used for peak power measurements, Method # 1 settings are used for the second PPSD trace.

#### RESULTS

##### CHAIN 0

Channel	Frequency (MHz)	Peak Excursion (dB)	Limit (dB)	Margin (dB)
Low	5180	9.39	13	-3.61
High	5240	11.13	13	-1.87

##### CHAIN 1

Channel	Frequency (MHz)	Peak Excursion (dB)	Limit (dB)	Margin (dB)
Low	5180	11.79	13	-1.21
High	5240	11.83	13	-1.17

**CHAIN 0**

**PEAK EXCURSION**

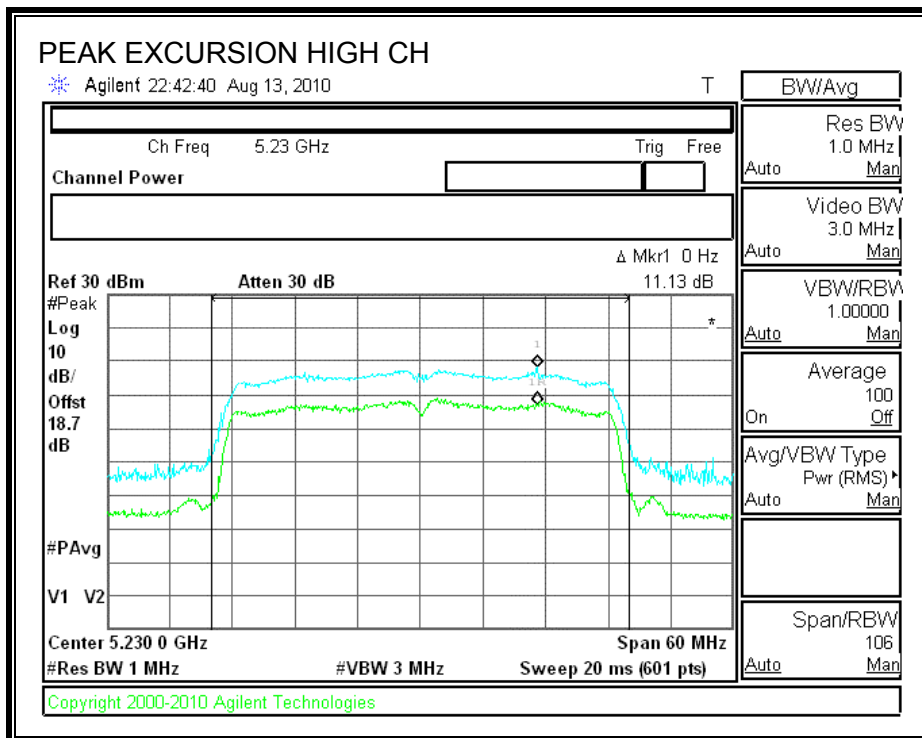
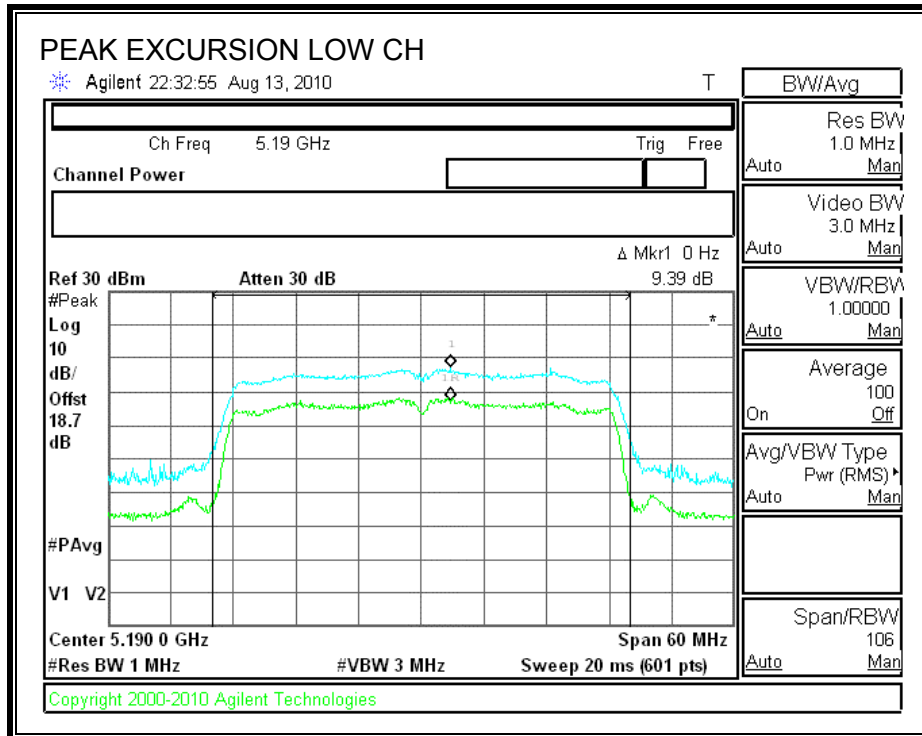

**CHAIN 1**

**PEAK EXCURSION**

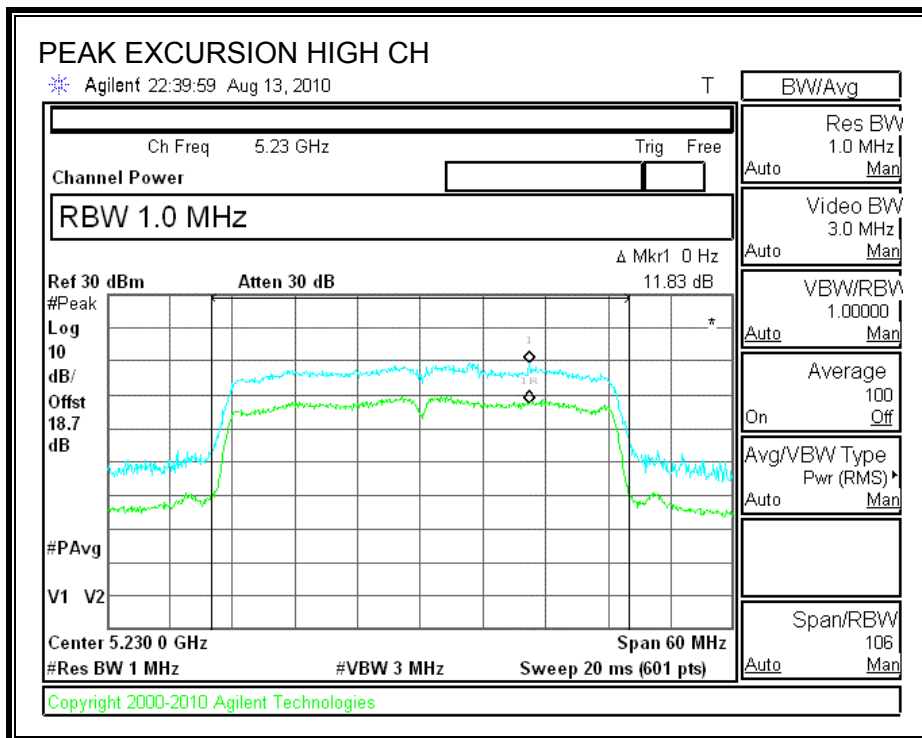
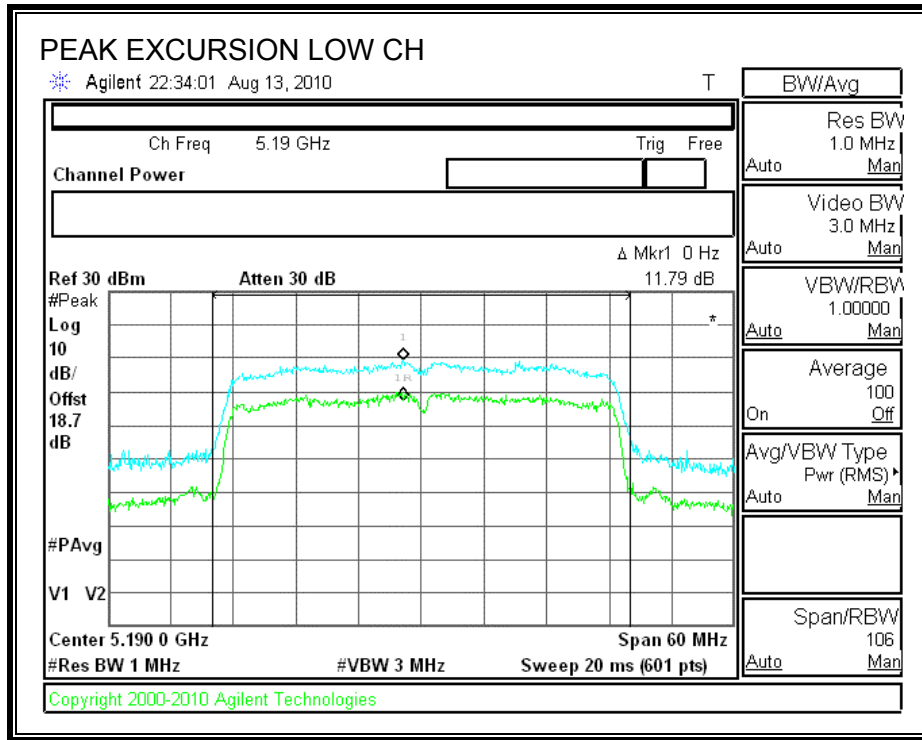



## 7.4.5. CONDUCTED SPURIOUS EMISSIONS

### LIMITS

FCC §15.407 (b) (1)

IC RSS-210 A9.3 (1)

For transmitters operating in the 5.15-5.25 GHz band: all emissions outside of the 5.15-5.35 GHz band shall not exceed an EIRP of -27 dBm / MHz.

### TEST PROCEDURE

Conducted RF measurements of the transmitter output are made to confirm that the EUT antenna port conducted emissions meet the specified limit and to identify any spurious signals that require further investigation or measurements on the radiated emissions site.

The transmitter output is connected to the spectrum analyzer. The resolution bandwidth is set to 1 MHz. The video bandwidth is set to 1 MHz. Peak detection measurements are compared to EIRP limit, adjusted for the maximum antenna gain.

Measurements are made over the 30 MHz to 40 GHz range with the transmitter set to the lowest, middle, and highest channels.

**SPURIOUS EMISSIONS WITH COMBINER**

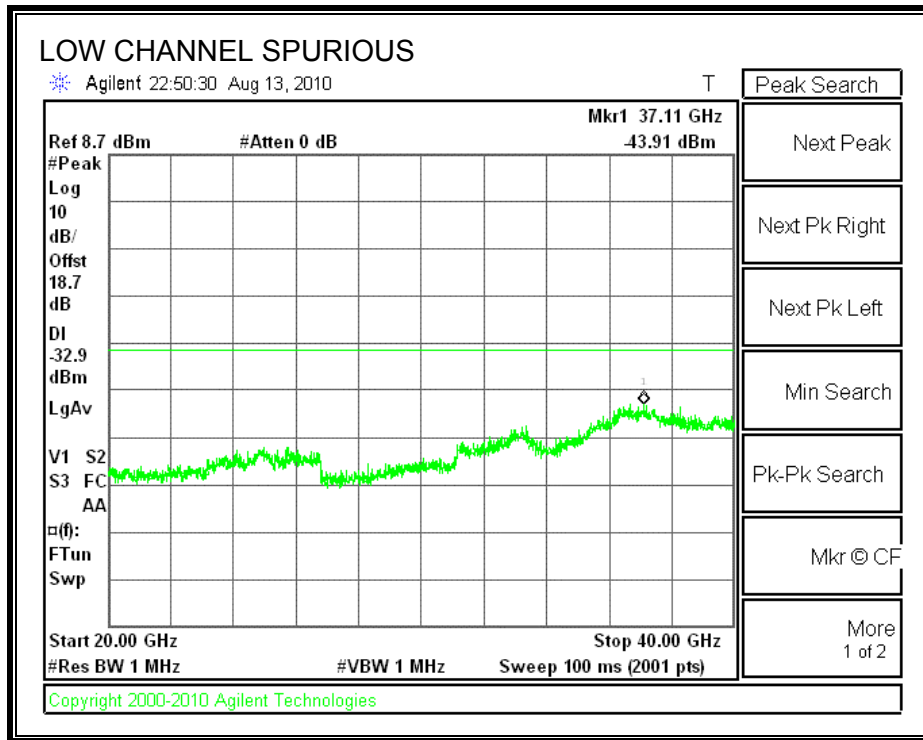
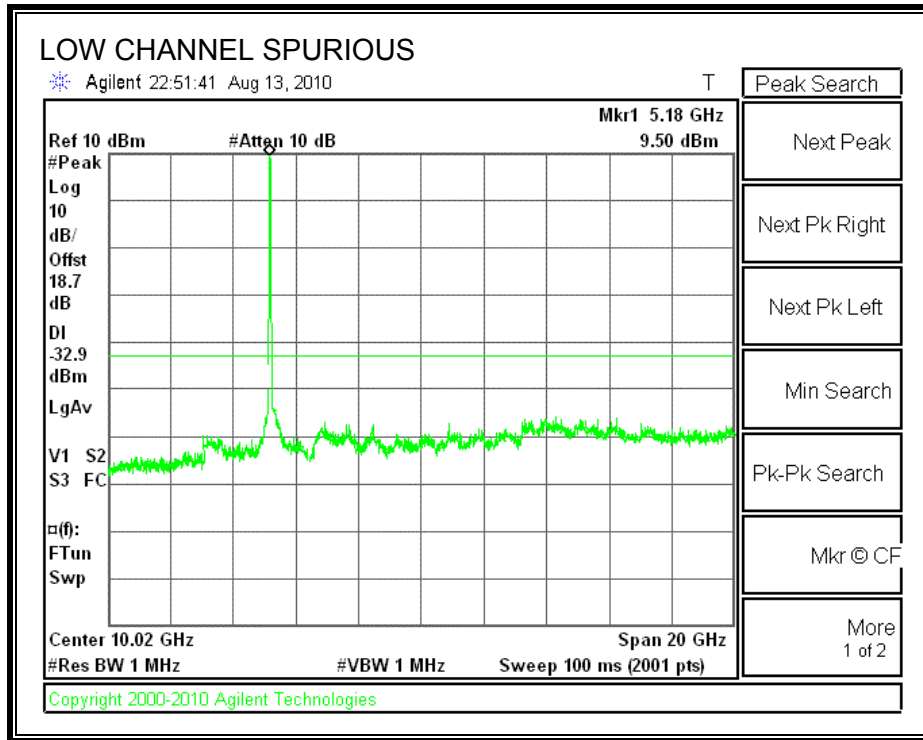

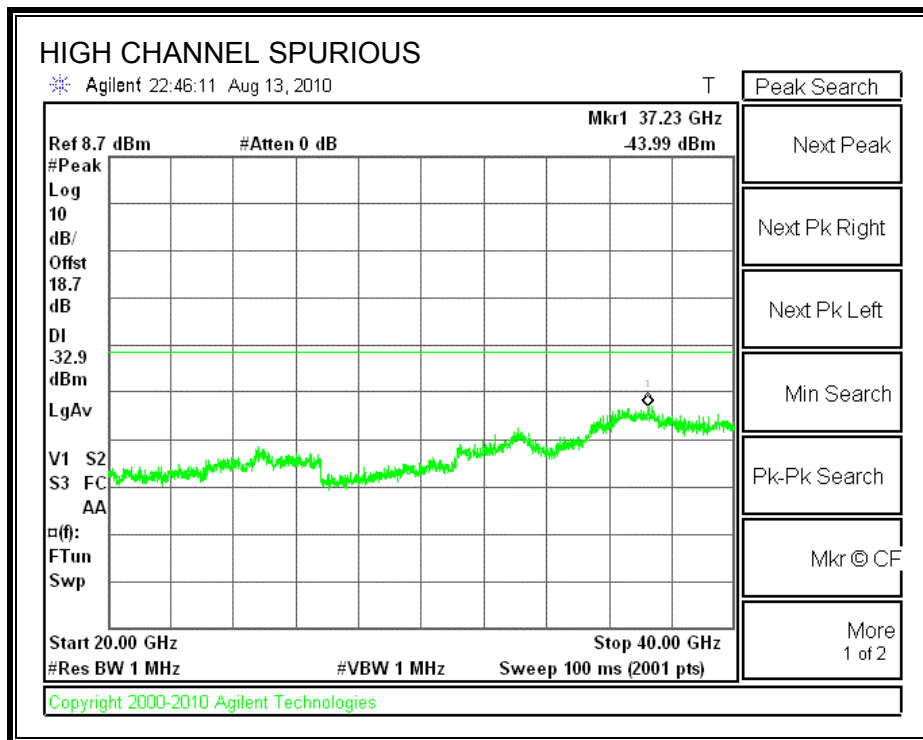
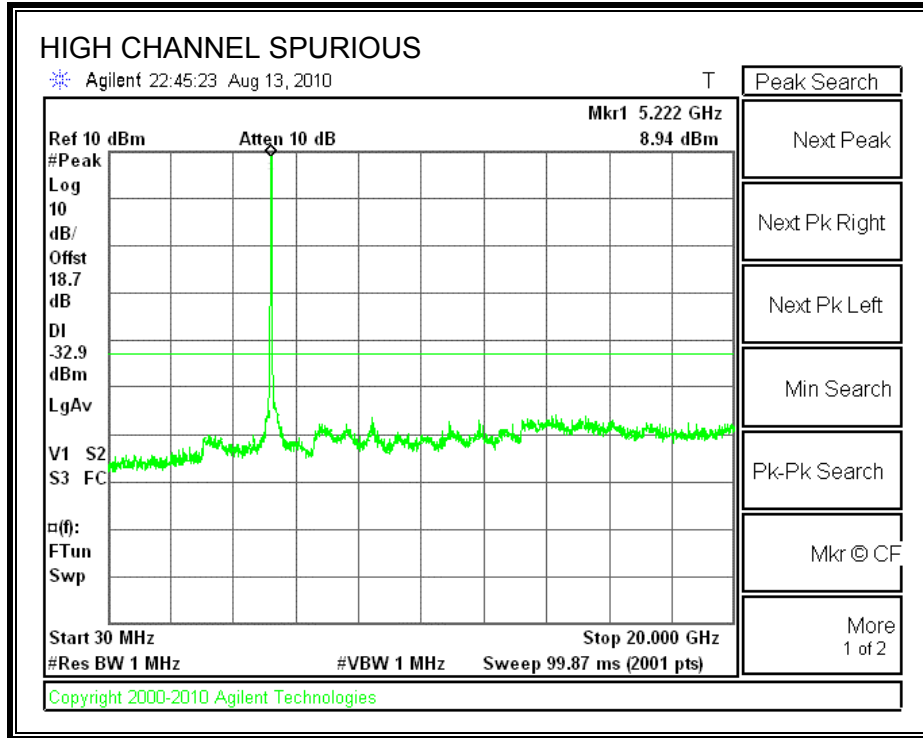

**HT40 MCS12 SDM – Non-Coherent**

**7.4.6. 26 dB and 99% BANDWIDTH**

**LIMITS**

None; for reporting purposes only.

**TEST PROCEDURE**

The transmitter outputs are connected to the spectrum analyzer via a combiner. The RBW is set to 1% to 3% of the measured bandwidth. The VBW is set to 3 times the RBW. The sweep time is coupled. The spectrum analyzer internal bandwidth function is utilized.

**RESULTS**

**CHAIN 0**

Channel	Frequency (MHz)	26 dB Bandwidth (MHz)	99% Bandwidth (MHz)
Low	5190	37.313	36.1195
High	5230	38.434	35.6845

**CHAIN 1**

Channel	Frequency (MHz)	26 dB Bandwidth (MHz)	99% Bandwidth (MHz)
Low	5190	37.317	36.2809
High	5230	38.051	35.7459

**CHAIN 0**

**26 dB and 99% BANDWIDTH**

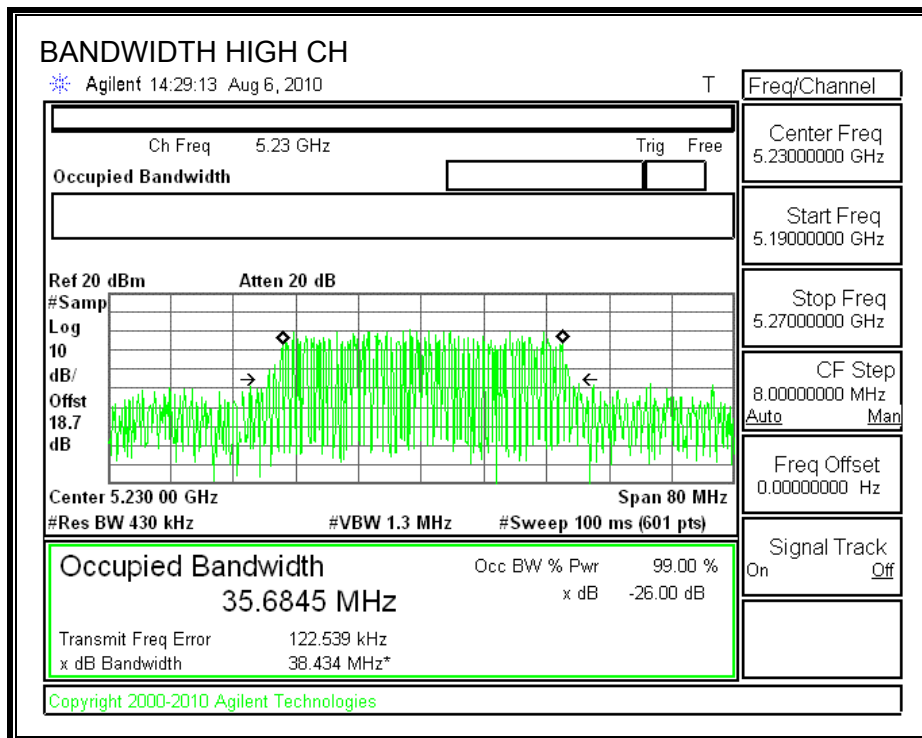
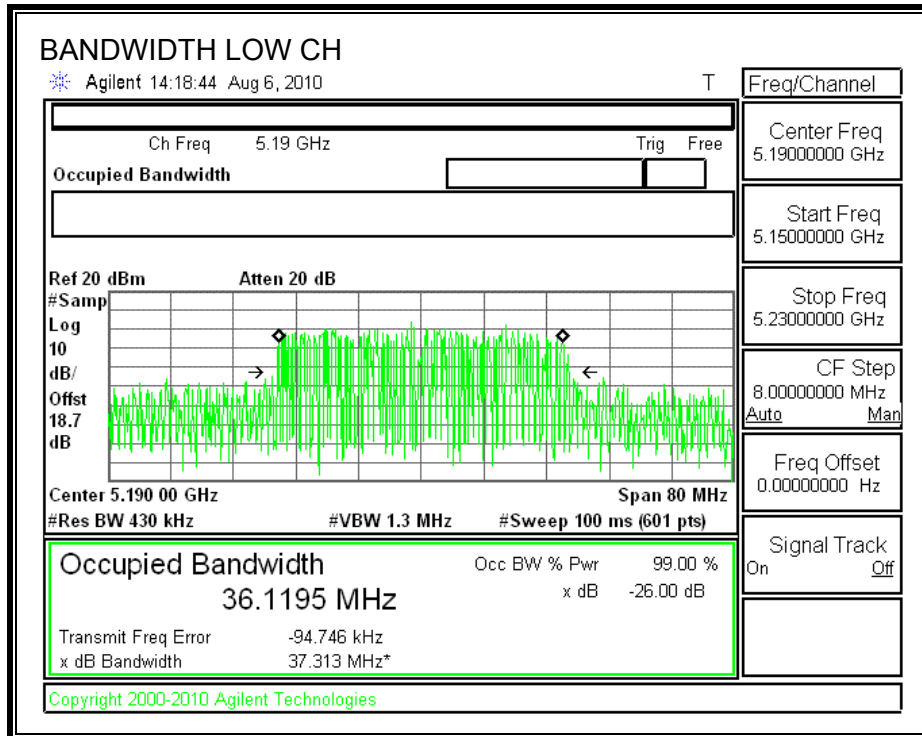

**CHAIN 1**

**26 dB and 99% BANDWIDTH**

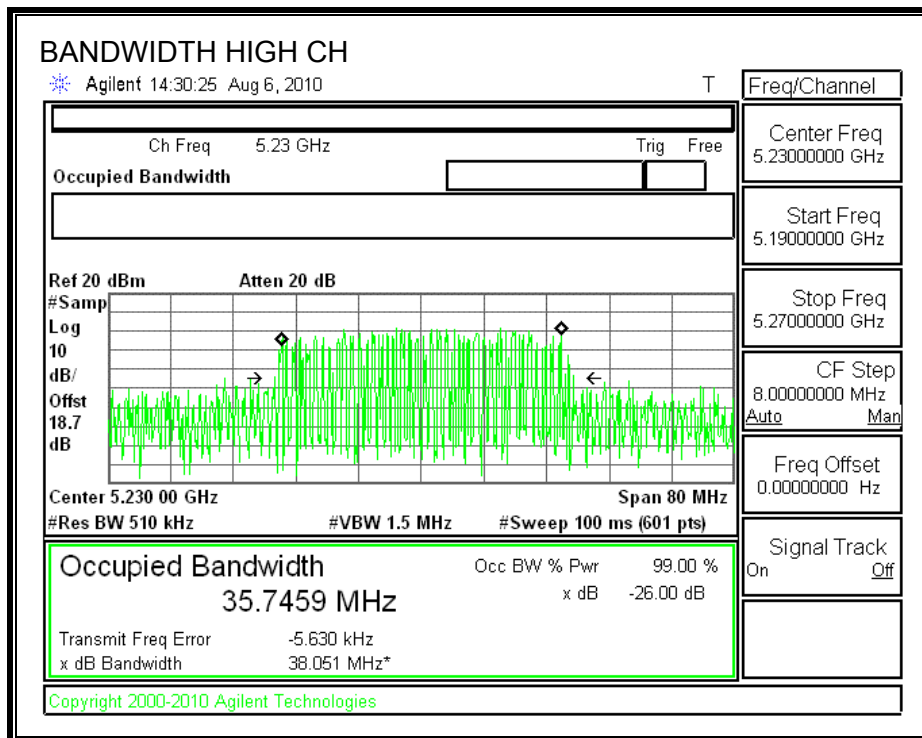
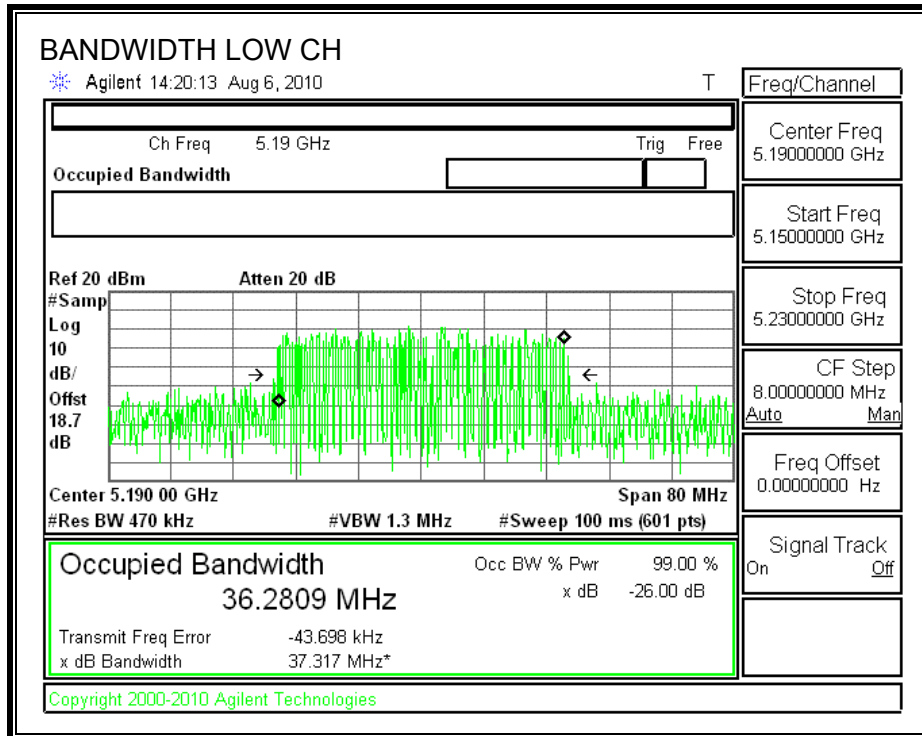

### 7.4.7. OUTPUT POWER

#### LIMITS

FCC §15.407 (a) (1)

IC RSS-210 A9.2 (1)

For the 5.15-5.25 GHz band, the maximum conducted output power over the frequency band of operation shall not exceed the lesser of 50 mW or  $4 \text{ dBm} + 10 \log B$ , where B is the 26-dB emission bandwidth in MHz. If transmitting antennas of directional gain greater than 6 dBi are used, both the peak transmit power and the peak power spectral density shall be reduced by the amount in dB that the directional gain of the antenna exceeds 6 dBi.

The composite antenna gain is 5.93 dBi.

#### TEST PROCEDURE

The test is performed in accordance with FCC Public Notice: APPENDIX A Guidelines for Assessing Unlicensed National Information Infrastructure (U-NII) Devices – Part 15, Subpart E, August 2002.

The transmitter output operates continuously therefore Method # 1 is used.

#### RESULTS

##### Limit

Channel	Frequency (MHz)	Fixed Limit (dBm)	B (MHz)	4 + 10 Log B Limit (dBm)	Antenna Gain (dBi)	Limit (dBm)
Low	5190	17	37.313	19.72	5.93	17.00
High	5230	17	38.434	19.85	5.93	17.00

##### Individual Chain Results

Channel	Frequency (MHz)	Chain 0 Power (dBm)	Chain 1 Power (dBm)	Total Power (dBm)	Limit (dBm)	Margin (dB)
Low	5190	11.08	12.55	14.89	17.00	-2.11
High	5230	11.50	11.83	14.68	17.00	-2.32

**CHAIN 0 OUTPUT POWER**

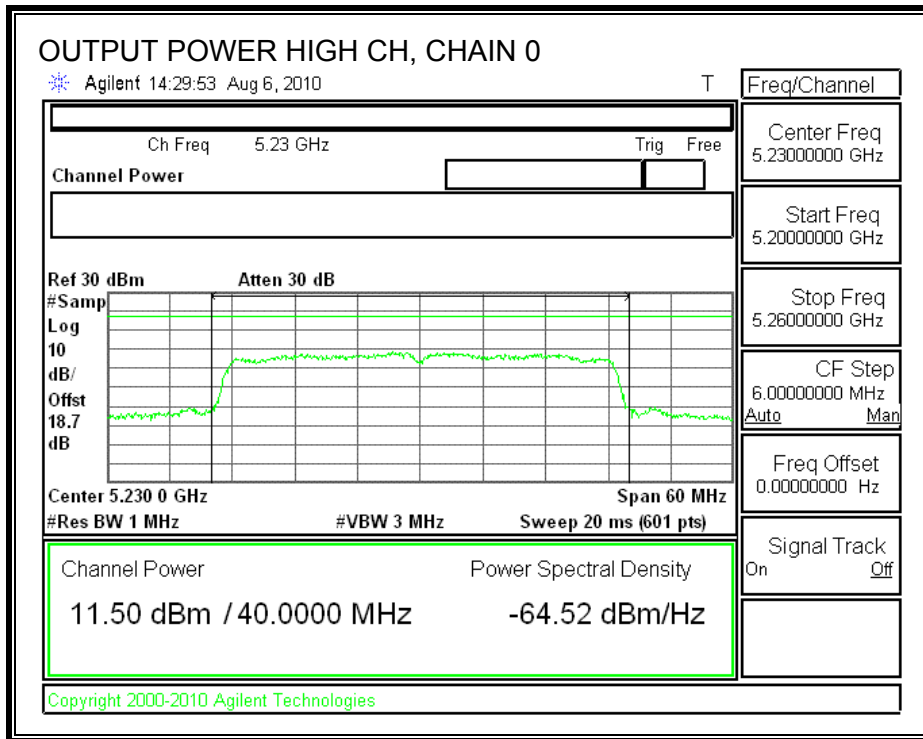
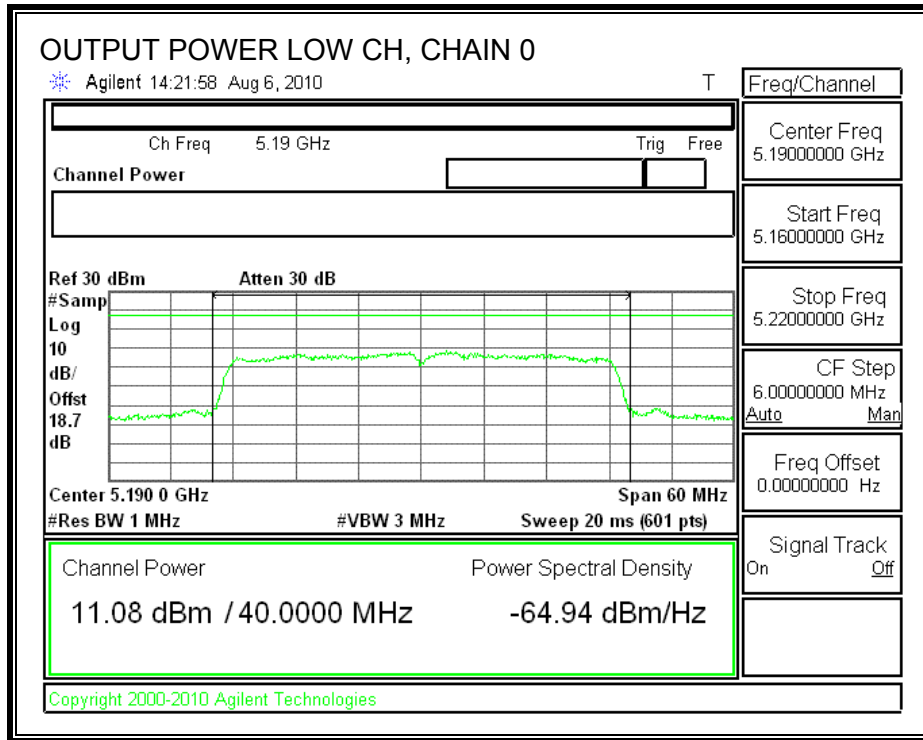



**CHAIN 1 OUTPUT POWER**

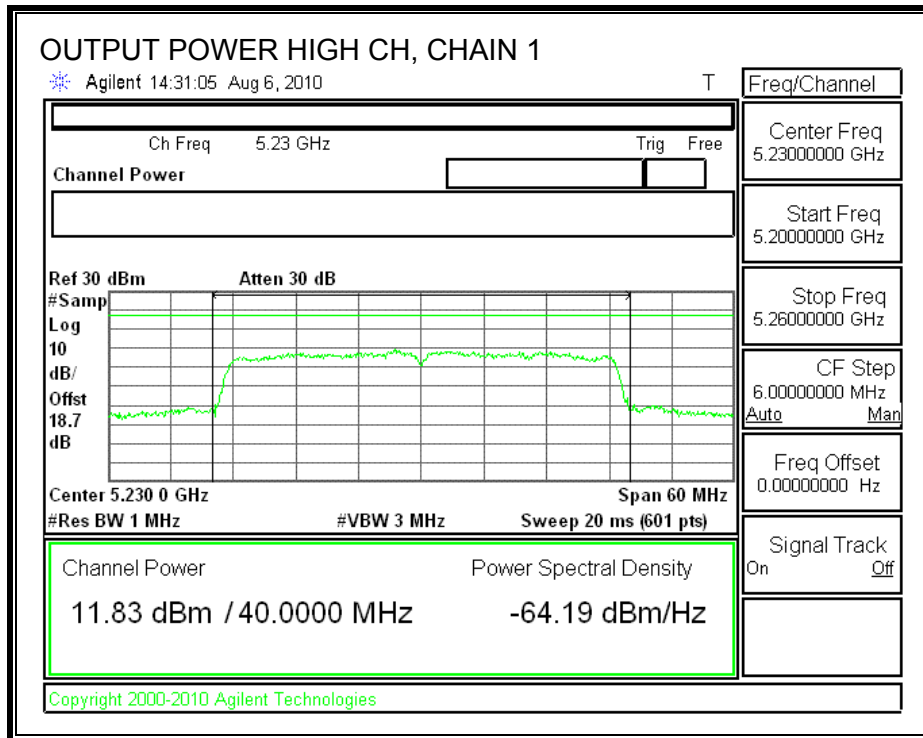
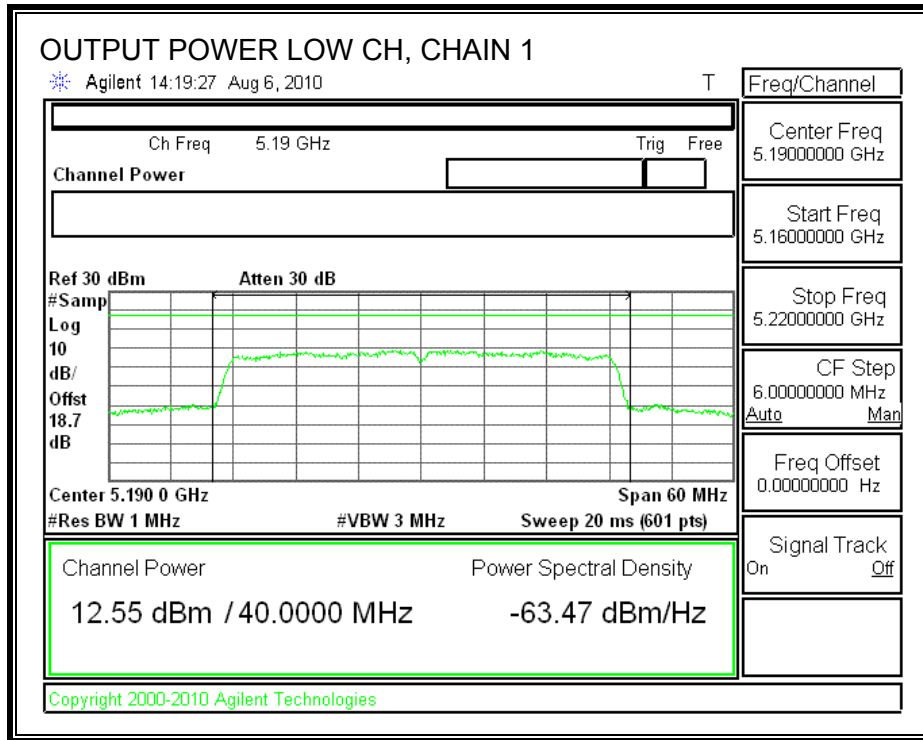

### 7.4.8. PEAK POWER SPECTRAL DENSITY

#### LIMITS

FCC §15.407 (a) (1)

IC RSS-210 A9.2 (1)

For the 5.15-5.25 GHz band, the peak power spectral density shall not exceed 4 dBm in any 1 MHz band. If transmitting antennas of directional gain greater than 6 dBi are used, both the peak transmit power and the peak power spectral density shall be reduced by the amount in dB that the directional gain of the antenna exceeds 6 dBi.

The maximum antenna gain is 5.93 dBi, therefore the limit is 4 dBm.

#### TEST PROCEDURE

The test is performed in accordance with FCC Public Notice: APPENDIX A Guidelines for Assessing Unlicensed National Information Infrastructure (U-NII) Devices – Part 15, Subpart E, August 2002. PPSD method #2 was used.

#### RESULTS

Channel	Frequency (MHz)	PPSD With Combiner (dBm)	Limit (dBm)	Margin (dB)
Low	5190	1.51	4.00	-2.50
High	5230	1.58	4.00	-2.42

**POWER SPECTRAL DENSITY**

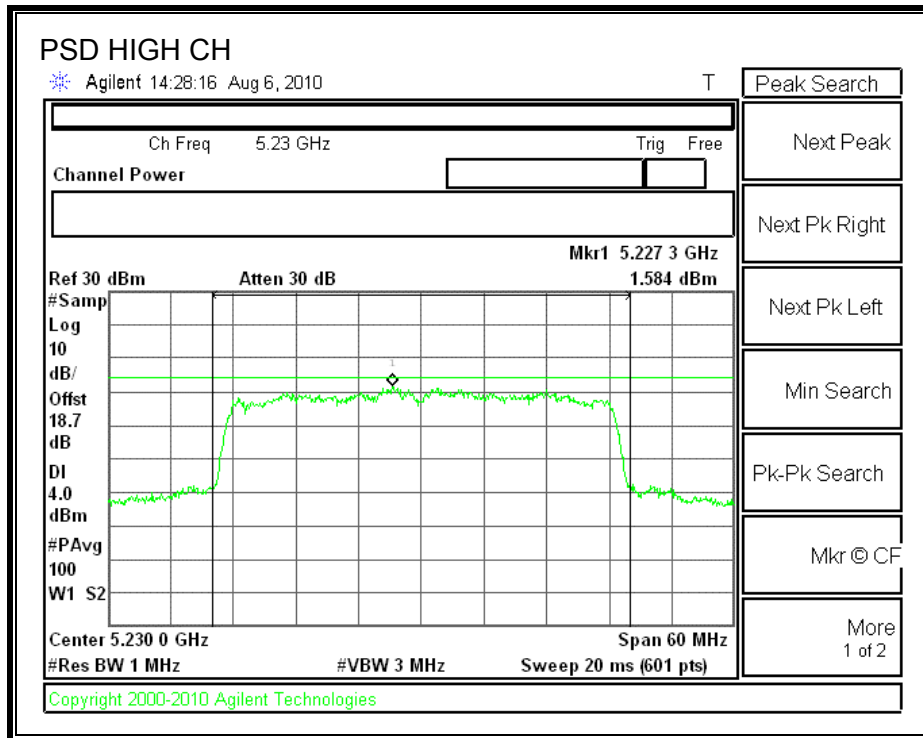
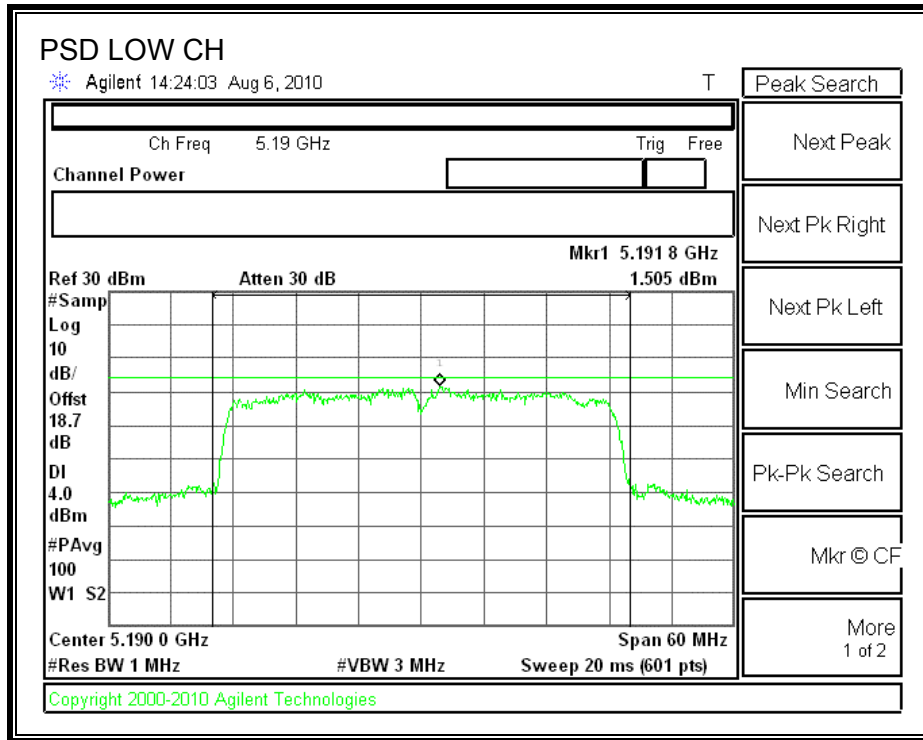

### 7.4.9. PEAK EXCURSION

#### LIMITS

FCC §15.407 (a) (6)

The ratio of the peak excursion of the modulation envelope (measured using a peak hold function) to the peak transmit power (measured as specified above) shall not exceed 13 dB across any 1 MHz bandwidth or the emission bandwidth whichever is less.

#### TEST PROCEDURE

The transmitter outputs are connected to the spectrum analyzer via a combiner.

The test is performed in accordance with FCC Public Notice: APPENDIX A Guidelines for Assessing Unlicensed National Information Infrastructure (U-NII) Devices – Part 15, Subpart E, August 2002.

Since Method # 1 was used for peak power measurements, Method # 1 settings are used for the second PPSD trace.

#### RESULTS

##### CHAIN 0

Channel	Frequency (MHz)	Peak Excursion (dB)	Limit (dB)	Margin (dB)
Low	5180	10.97	13	-2.03
High	5240	11.15	13	-1.85

##### CHAIN 1

Channel	Frequency (MHz)	Peak Excursion (dB)	Limit (dB)	Margin (dB)
Low	5180	12.32	13	-0.68
High	5240	11.78	13	-1.22

**CHAIN 0**

**PEAK EXCURSION**

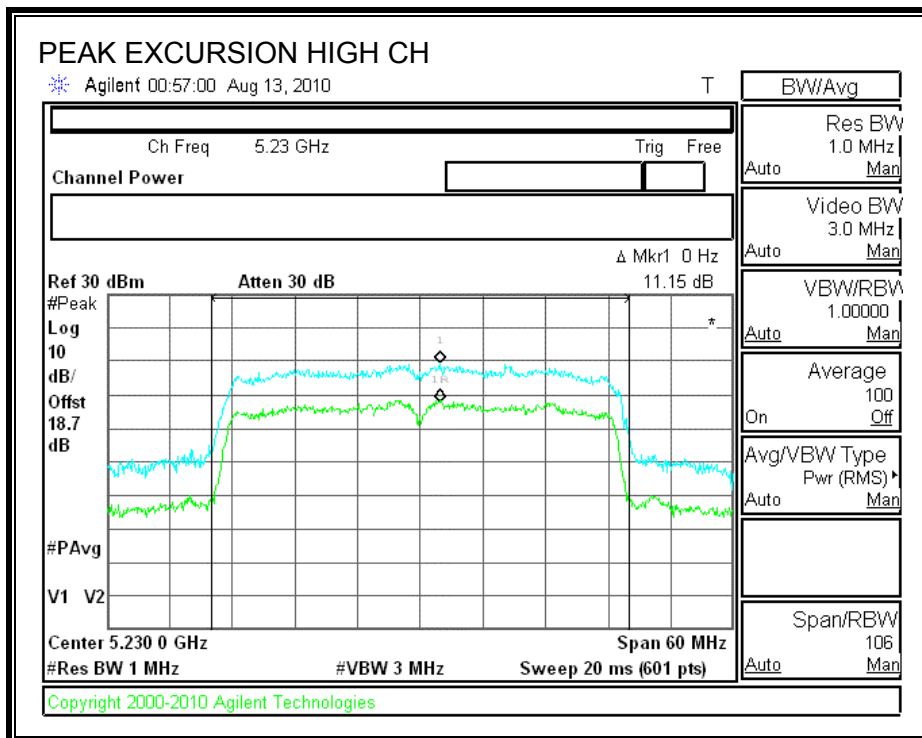
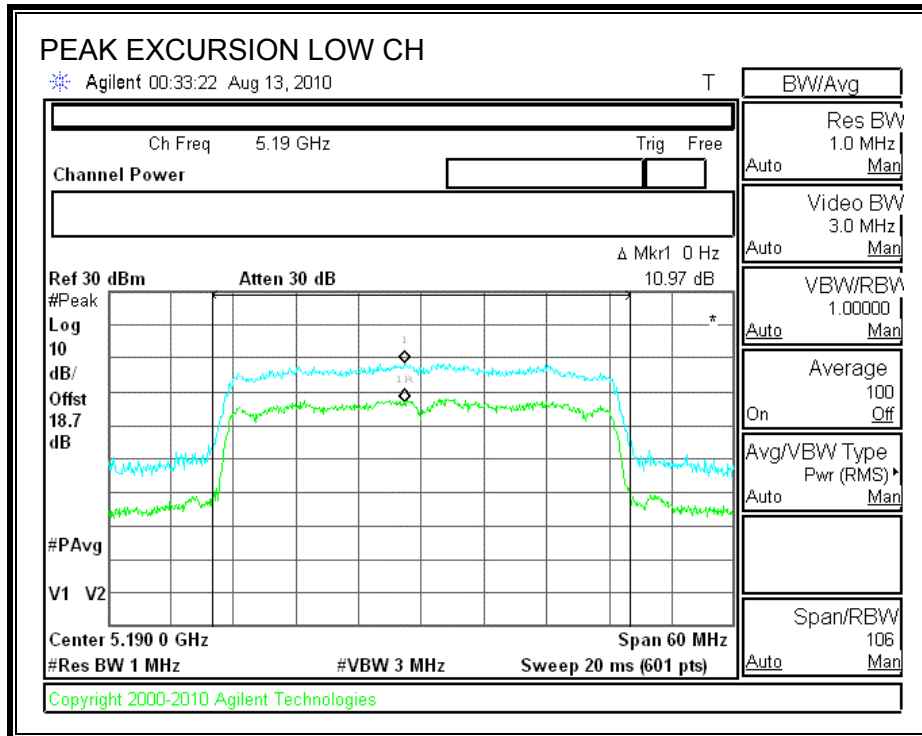

**CHAIN 1**

**PEAK EXCURSION**

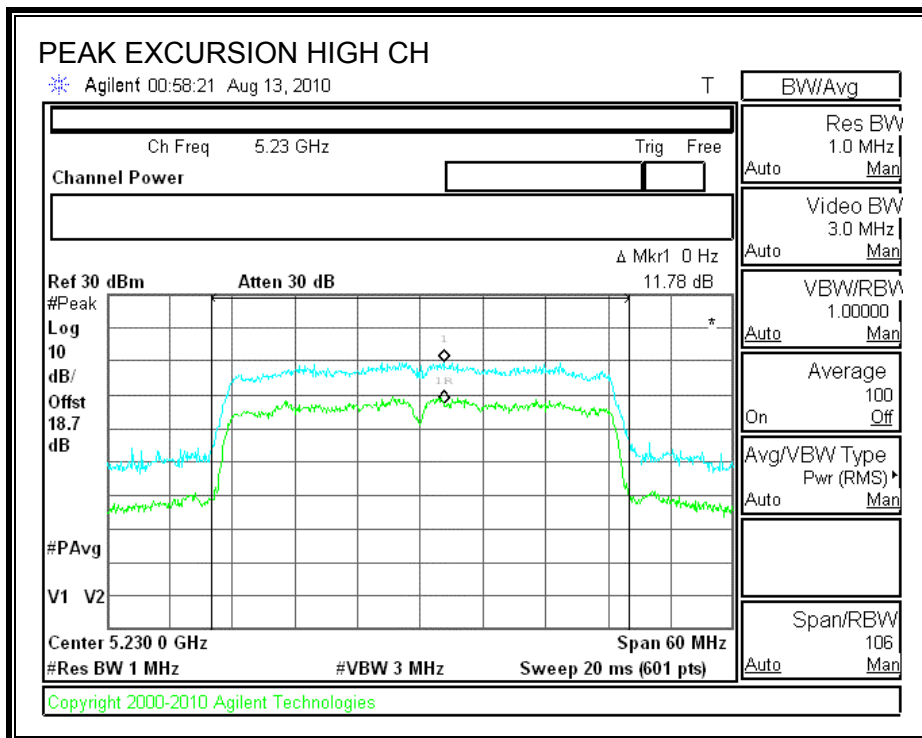
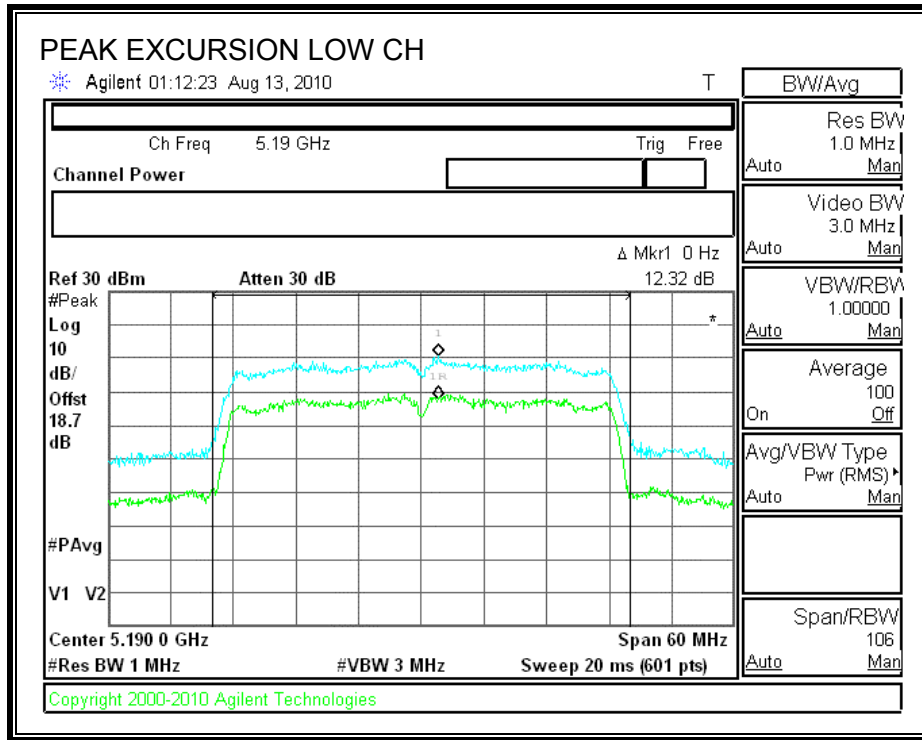

#### **7.4.10. CONDUCTED SPURIOUS EMISSIONS**

##### **LIMITS**

FCC §15.407 (b) (1)

IC RSS-210 A9.3 (1)

For transmitters operating in the 5.15-5.25 GHz band: all emissions outside of the 5.15-5.35 GHz band shall not exceed an EIRP of -27 dBm / MHz.

##### **TEST PROCEDURE**

Conducted RF measurements of the transmitter output are made to confirm that the EUT antenna port conducted emissions meet the specified limit and to identify any spurious signals that require further investigation or measurements on the radiated emissions site.

The transmitter output is connected to the spectrum analyzer. The resolution bandwidth is set to 1 MHz. The video bandwidth is set to 1 MHz. Peak detection measurements are compared to EIRP limit, adjusted for the maximum antenna gain.

Measurements are made over the 30 MHz to 40 GHz range with the transmitter set to the lowest, middle, and highest channels.

**SPURIOUS EMISSIONS WITH COMBINER**

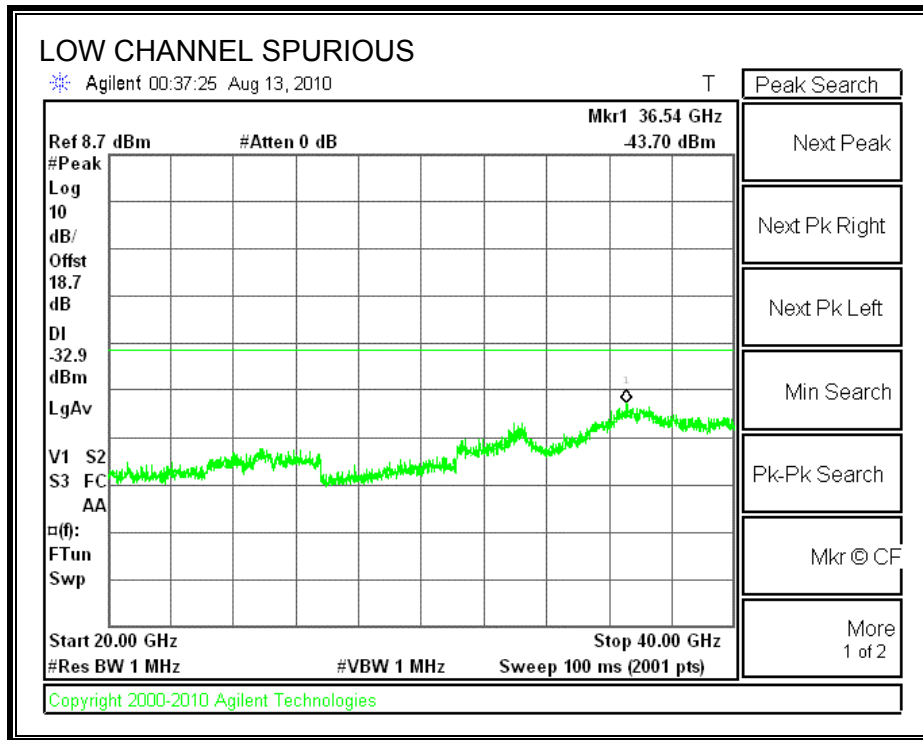
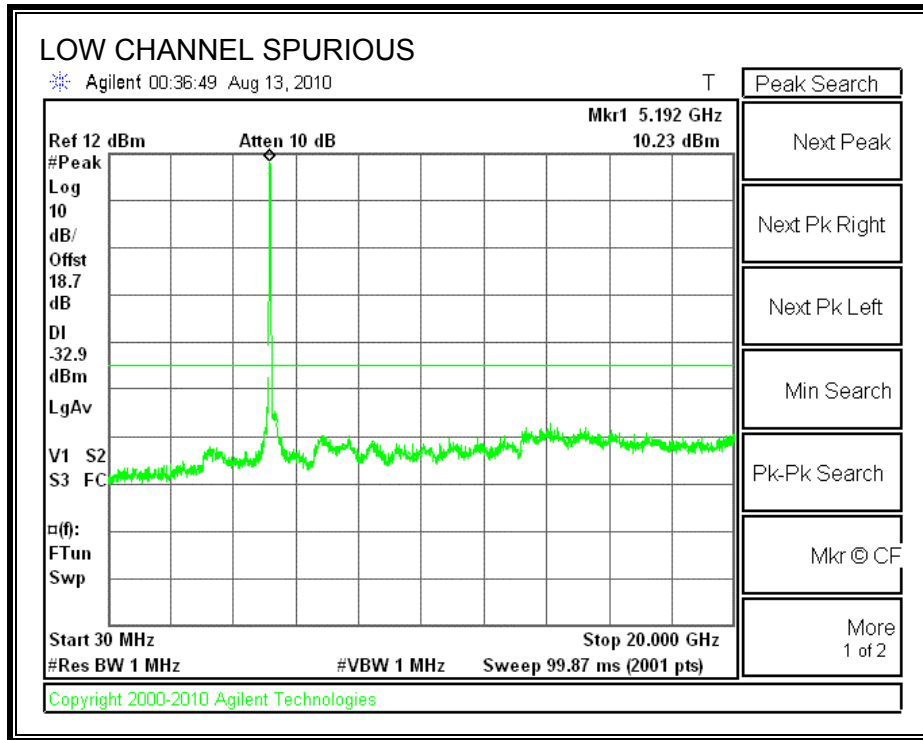



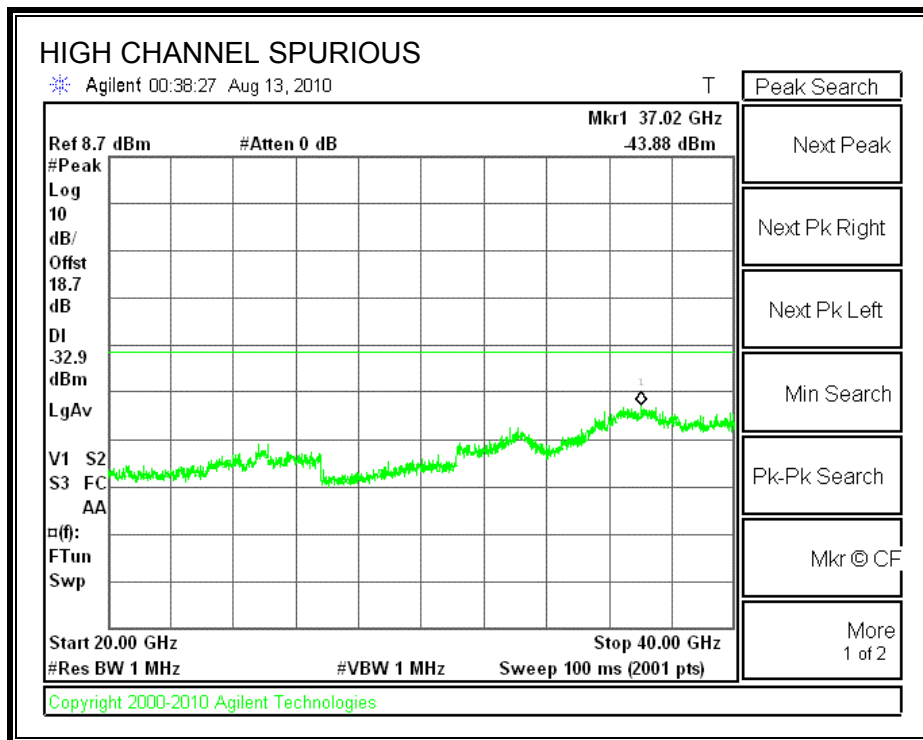
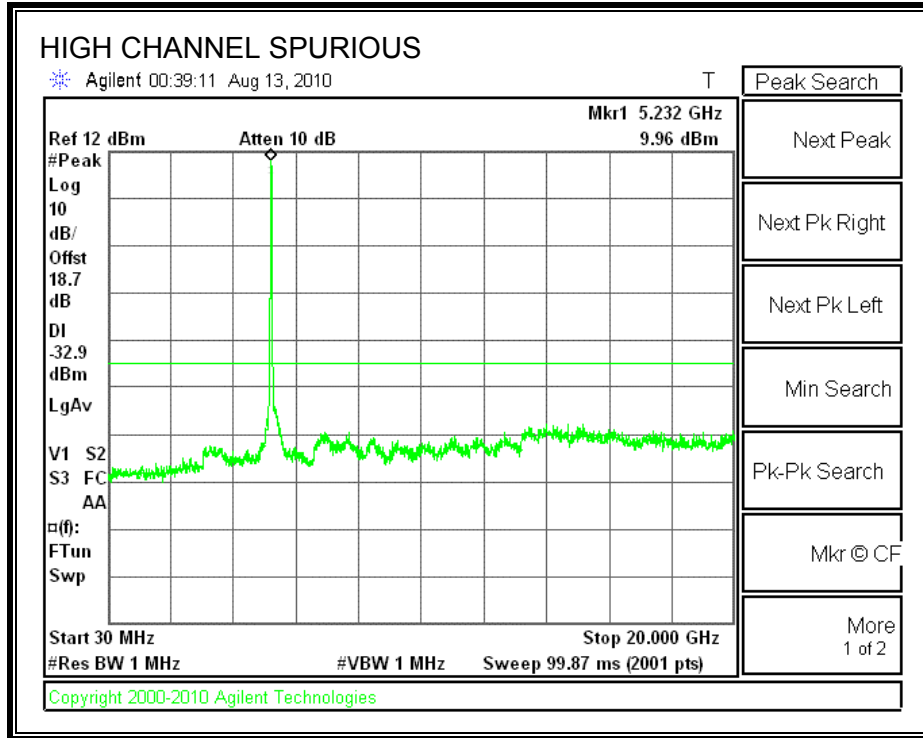

## 7.5. 802.11a MODE IN THE 5.3 GHz BAND

### 7.5.1. 26 dB and 99% BANDWIDTH

#### LIMITS

None; for reporting purposes only.

#### TEST PROCEDURE

The transmitter output is connected to the spectrum analyzer. The RBW is set to 1% to 3% of the measured bandwidth. The VBW is set to 3 times the RBW. The sweep time is coupled. The spectrum analyzer internal bandwidth function is utilized.

#### RESULTS

Channel	Frequency (MHz)	26 dB Bandwidth (MHz)	99% Bandwidth (MHz)
Low	5260	24.216	16.4191
Middle	5300	25.230	16.3593
High	5320	18.519	16.3261

**26 dB & 99% BANDWIDTH**

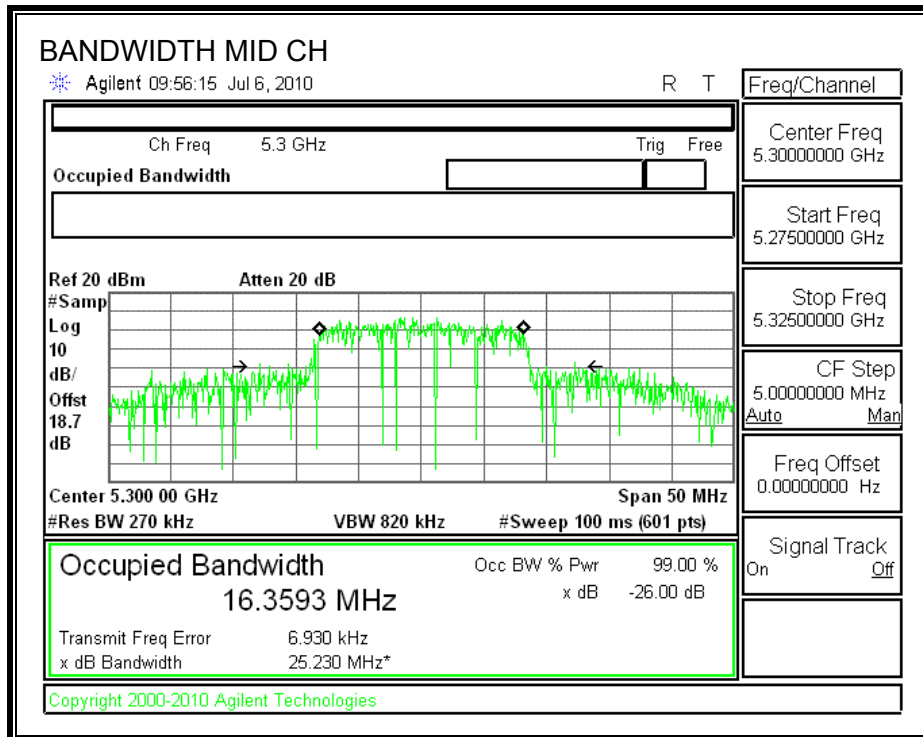
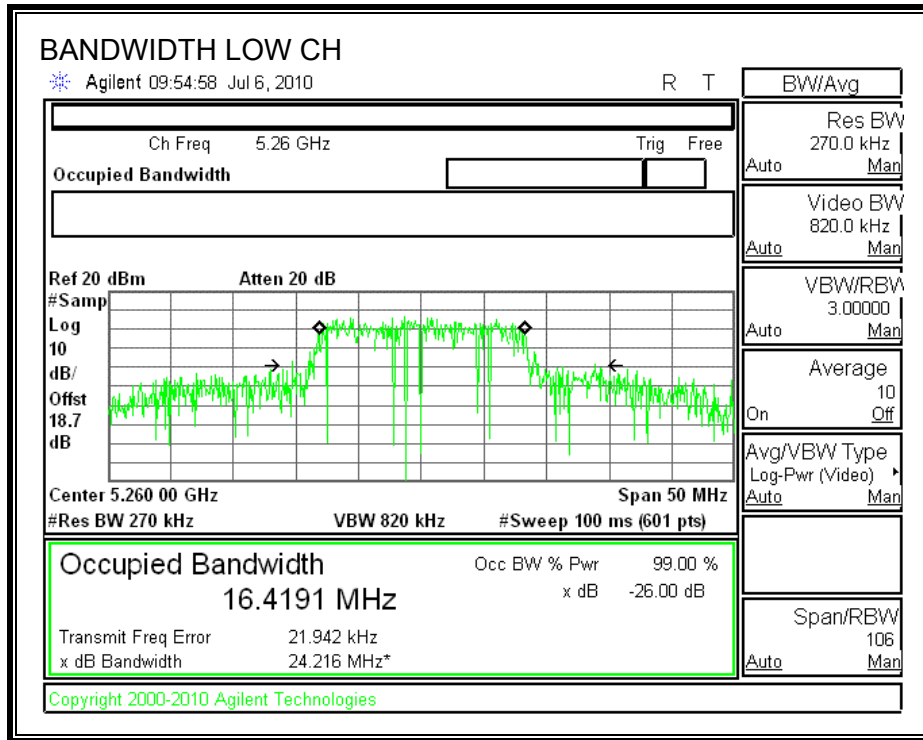

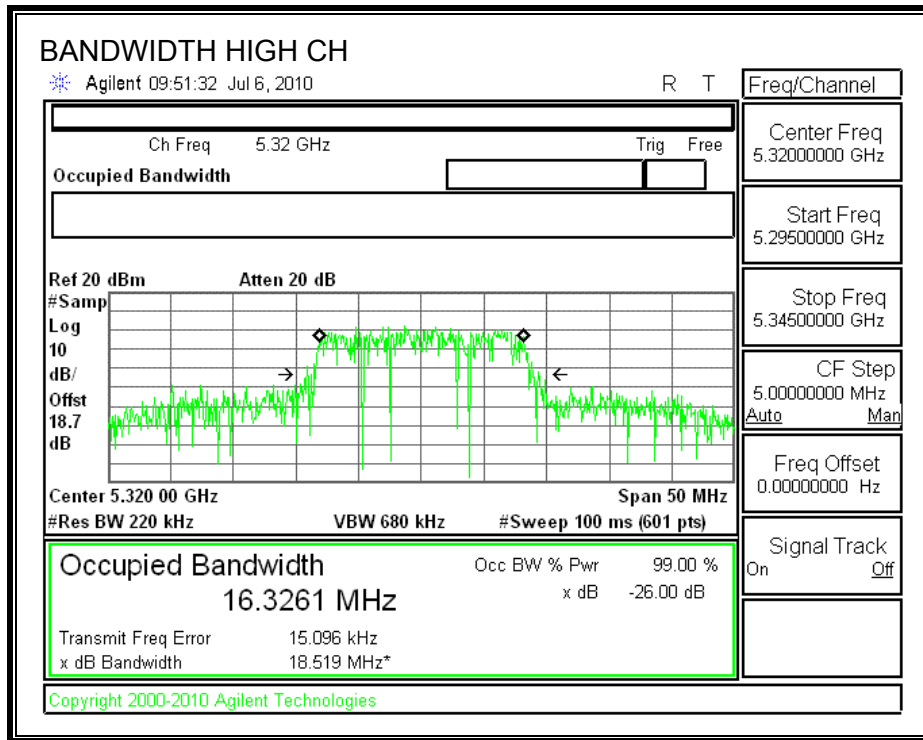

## 7.5.2. OUTPUT POWER

### LIMITS

FCC §15.407 (a) (2)

IC RSS-210 A9.2 (2)

For the 5.25-5.35 GHz band, the maximum conducted output power over the frequency band of operation shall not exceed the lesser of 250 mW or  $11 \text{ dBm} + 10 \log B$ , where B is the 26-dB emission bandwidth in MHz. If transmitting antennas of directional gain greater than 6 dBi are used, both the peak transmit power and the peak power spectral density shall be reduced by the amount in dB that the directional gain of the antenna exceeds 6 dBi.

The maximum antenna gain is 6.12dBi.

### TEST PROCEDURE

The test is performed in accordance with FCC Public Notice: APPENDIX A Guidelines for Assessing Unlicensed National Information Infrastructure (U-NII) Devices – Part 15, Subpart E, August 2002.

The transmitter output operates continuously therefore Method # 1 is used.

### RESULTS

#### Limit

Channel	Frequency (MHz)	Fixed Limit (dBm)	B (MHz)	11 + 10 Log B Limit (dBm)	Antenna Gain (dBi)	Limit (dBm)
Low	5260	24	24.216	24.84	6.12	23.88
Mid	5300	24	25.230	25.02	6.12	23.88
High	5320	24	18.519	23.68	6.12	23.56

#### Results

Channel	Frequency (MHz)	Power (dBm)	Limit (dBm)	Margin (dB)
Low	5260	17.70	23.88	-6.18
Mid	5300	17.65	23.88	-6.23
High	5320	14.67	23.56	-8.89

**OUTPUT POWER**

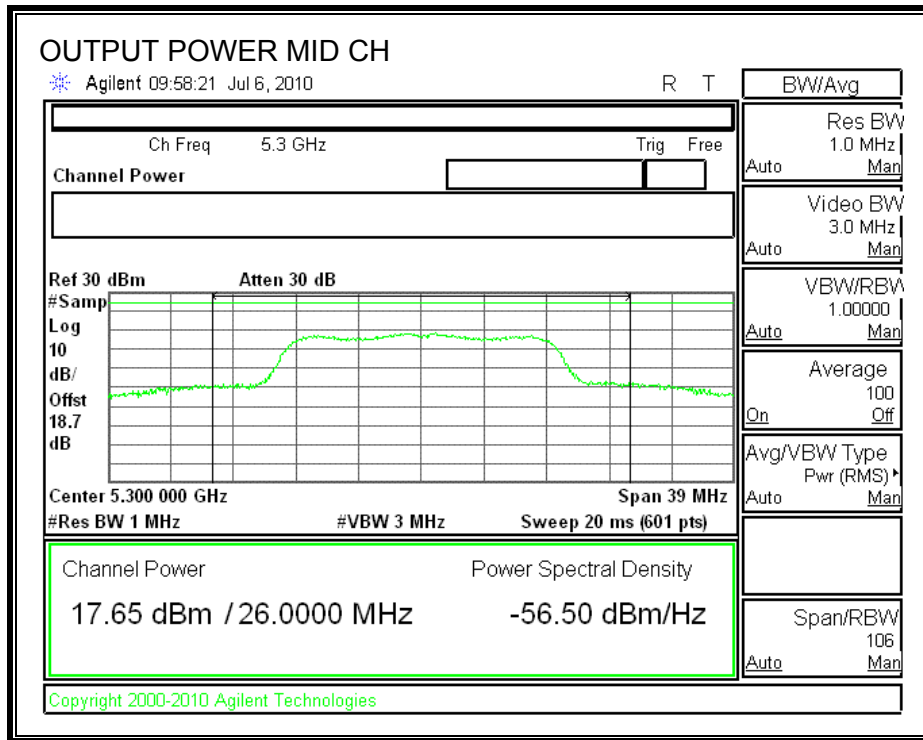
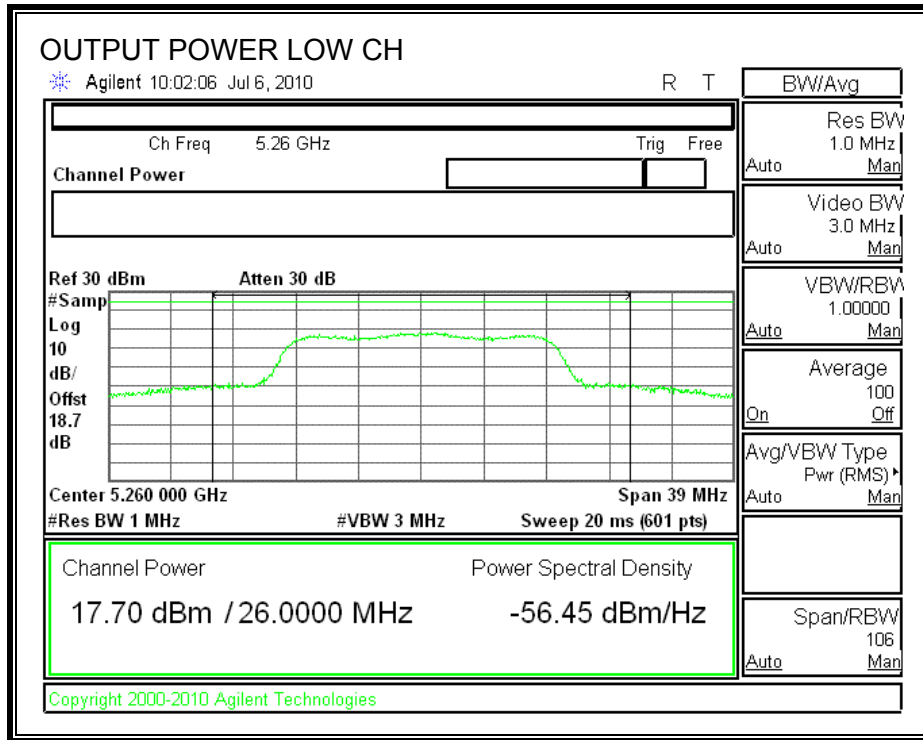

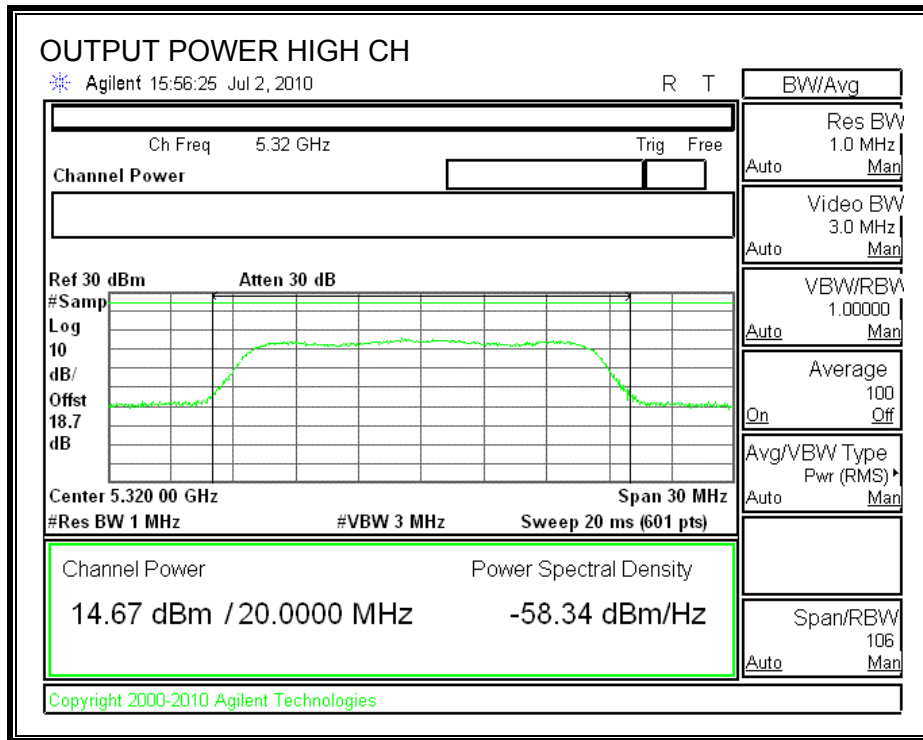

### 7.5.3. PEAK POWER SPECTRAL DENSITY

#### LIMITS

FCC §15.407 (a) (2)

IC RSS-210 A9.2 (2)

For the 5.25–5.35 GHz band, the peak power spectral density shall not exceed 11 dBm in any 1 MHz band. If transmitting antennas of directional gain greater than 6 dBi are used, both the peak transmit power and the peak power spectral density shall be reduced by the amount in dB that the directional gain of the antenna exceeds 6 dBi.

The maximum antenna gain is equal to 6.12 dBi, therefore the limit is 10.88 dBm.

#### TEST PROCEDURE

The test is performed in accordance with FCC Public Notice: APPENDIX A Guidelines for Assessing Unlicensed National Information Infrastructure (U-NII) Devices – Part 15, Subpart E, August 2002. PPSD method #2 was used.

#### RESULTS

Channel	Frequency (MHz)	PPSD (dBm)	Limit (dBm)	Margin (dB)
Low	5260	8.24	10.88	-2.64
Middle	5300	8.43	10.88	-2.45
High	5320	4.99	10.88	-5.89



**POWER SPECTRAL DENSITY**

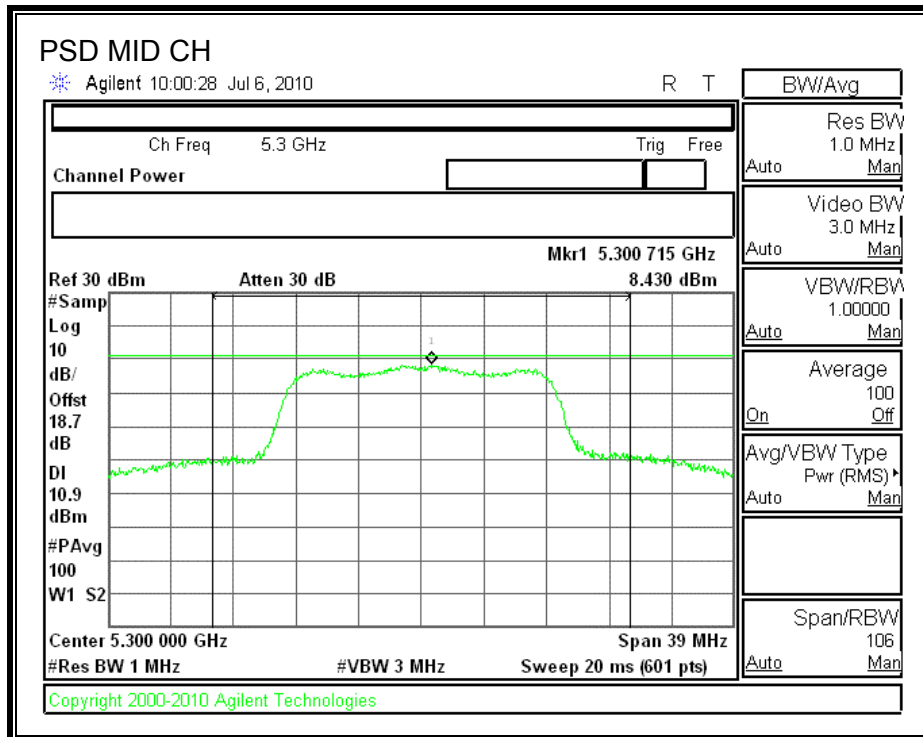
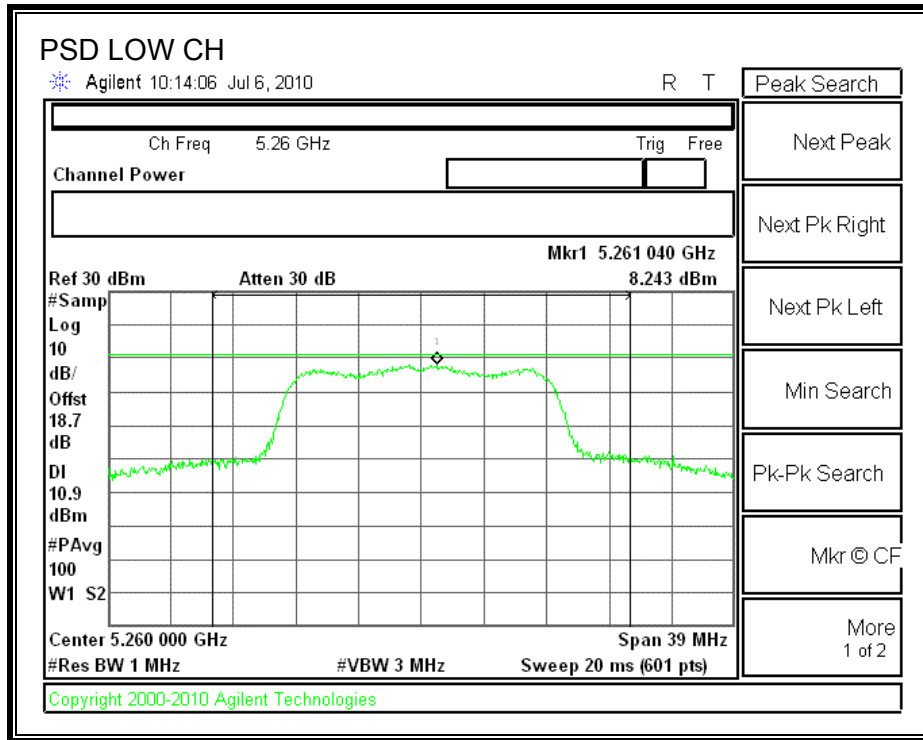

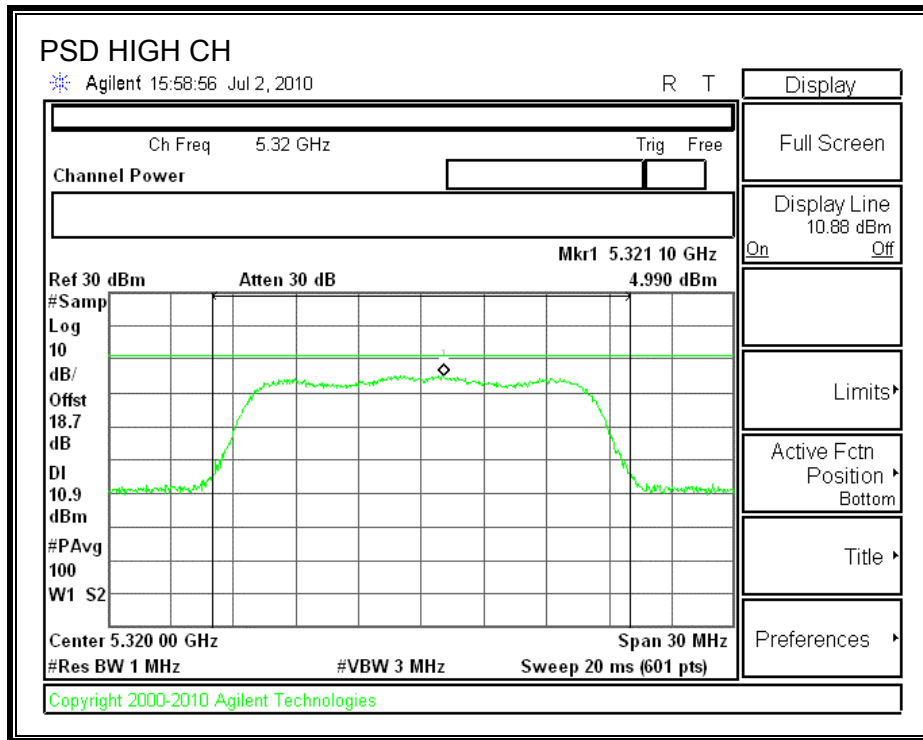

### 7.5.4. PEAK EXCURSION

#### LIMITS

FCC §15.407 (a) (6)

The ratio of the peak excursion of the modulation envelope (measured using a peak hold function) to the peak transmit power (measured as specified above) shall not exceed 13 dB across any 1 MHz bandwidth or the emission bandwidth whichever is less.

#### TEST PROCEDURE

The test is performed in accordance with FCC Public Notice: APPENDIX A Guidelines for Assessing Unlicensed National Information Infrastructure (U-NII) Devices – Part 15, Subpart E, August 2002.

Since Method # 1 was used for peak power measurements, Method # 1 settings are used for the second PPSD trace.

#### RESULTS

Channel	Frequency (MHz)	Peak Excursion (dB)	Limit (dB)	Margin (dB)
Low	5260	9.03	13	-3.97
Middle	5300	8.90	13	-4.10
High	5320	9.99	13	-3.01

**PEAK EXCURSION**

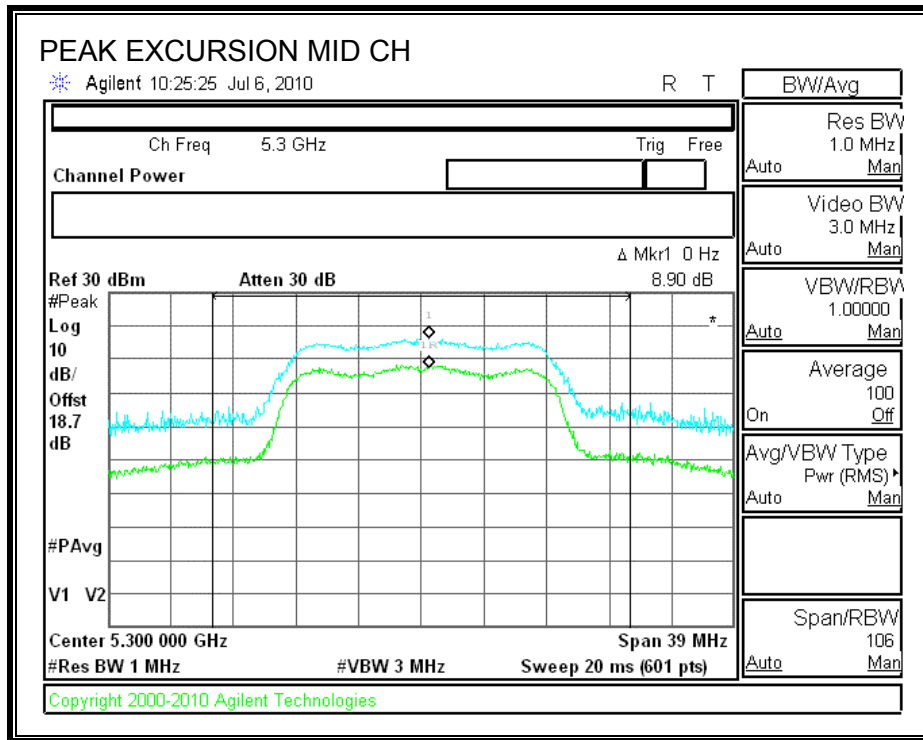
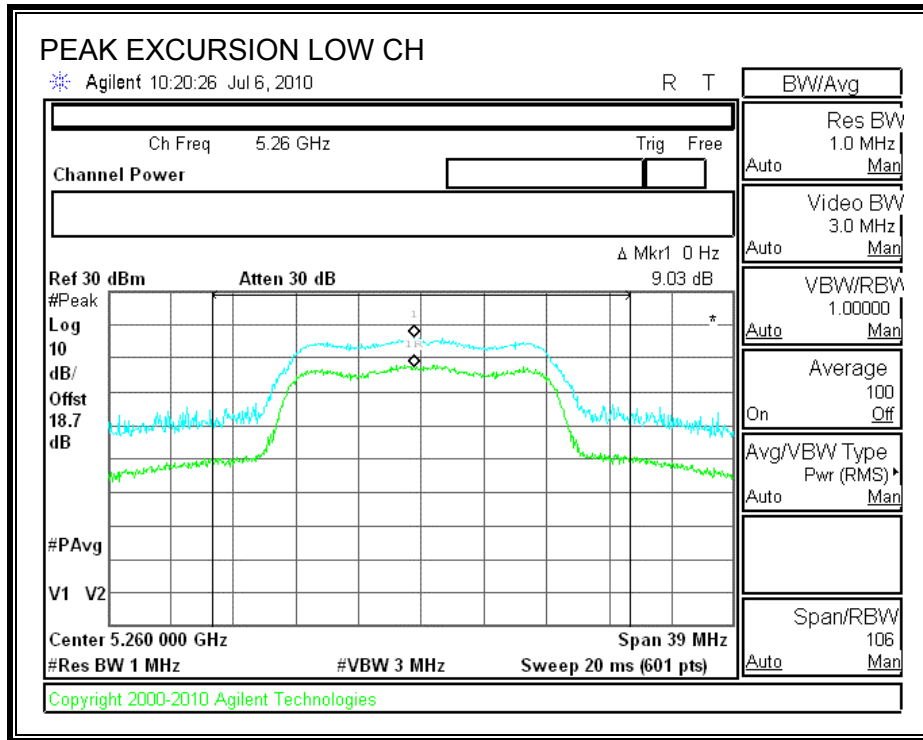

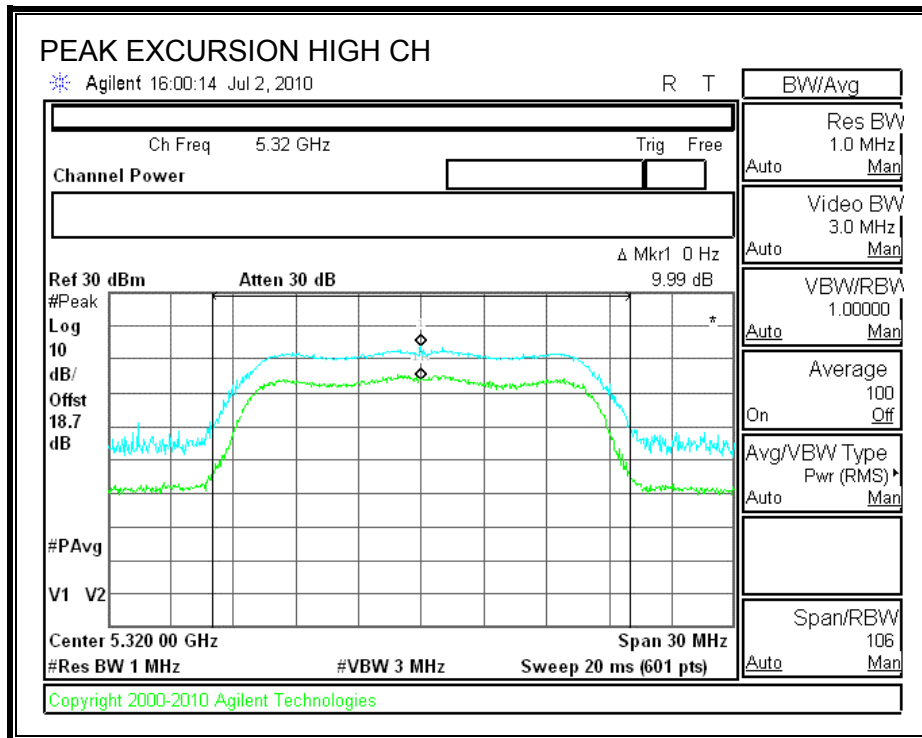

## 7.5.5. CONDUCTED SPURIOUS EMISSIONS

### LIMITS

FCC §15.407 (b) (2)

IC RSS-210 A9.3 (2)

For transmitters operating in the 5.25-5.35 GHz band: all emissions outside of the 5.25-5.35 GHz band shall not exceed an EIRP of -27 dBm / MHz.

Devices operating in the 5.25-5.35 GHz band that generate emissions in the 5.15-5.25 GHz band must meet all applicable technical requirements for operation in the 5.15-5.25 GHz band (including indoor use) or alternatively meet an out-of-band emission EIRP limit of -27 dBm/MHz in the 5.15-5.25 GHz band.

### TEST PROCEDURE

Conducted RF measurements of the transmitter output are made to confirm that the EUT antenna port conducted emissions meet the specified limit and to identify any spurious signals that require further investigation or measurements on the radiated emissions site.

The transmitter output is connected to the spectrum analyzer. The resolution bandwidth is set to 1 MHz. The video bandwidth is set to 1MHz. Peak detection measurements are compared to EIRP limit, adjusted for the maximum antenna gain.

Measurements are made over the 30 MHz to 40 GHz range with the transmitter set to the lowest, middle, and highest channels.

**SPURIOUS EMISSIONS**

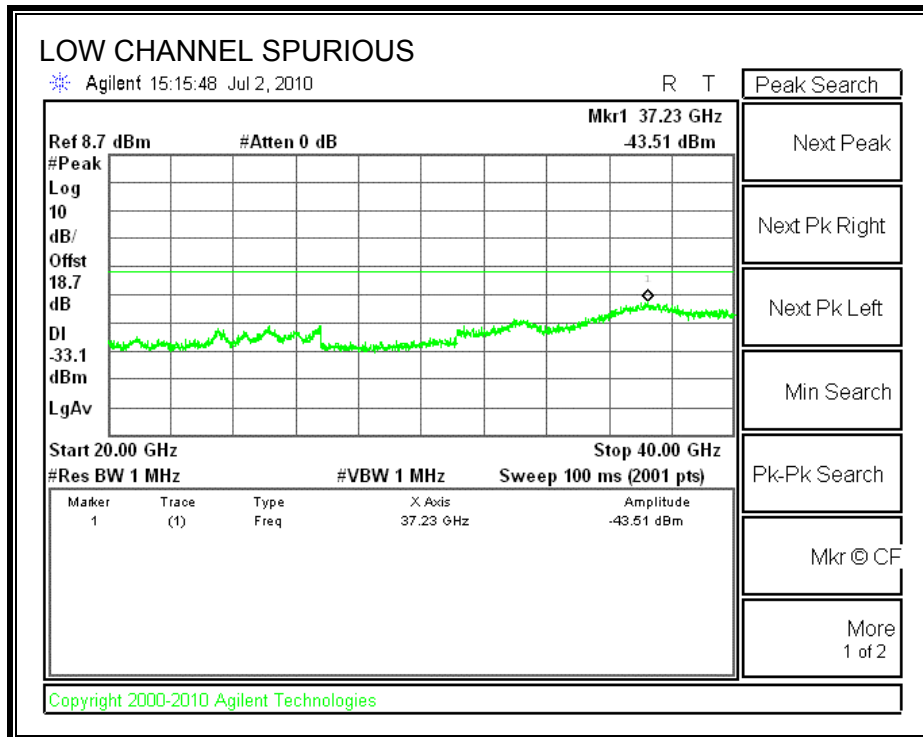
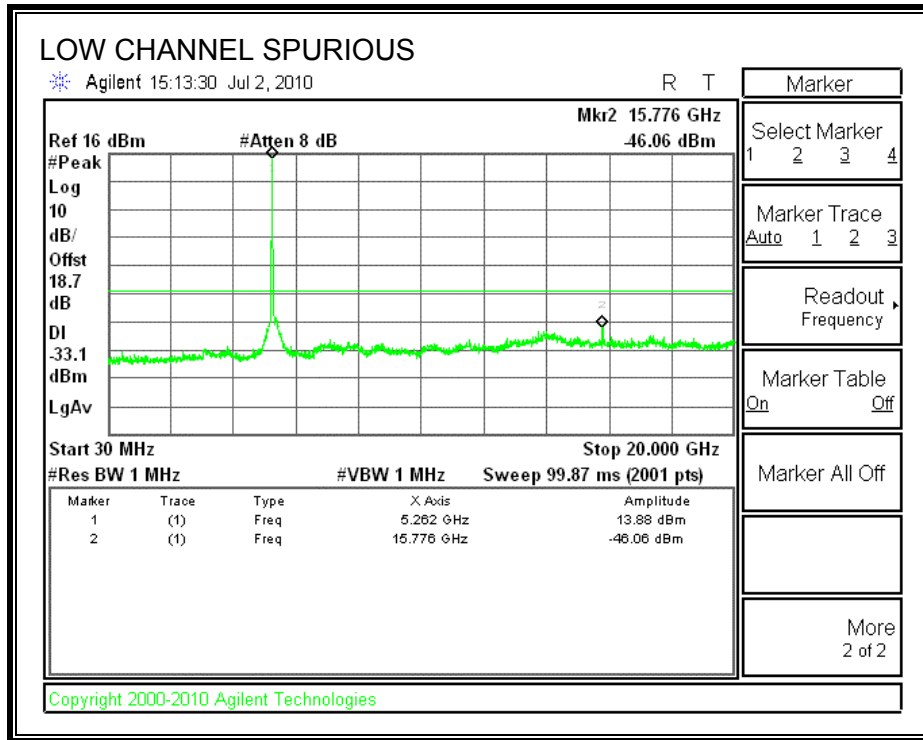

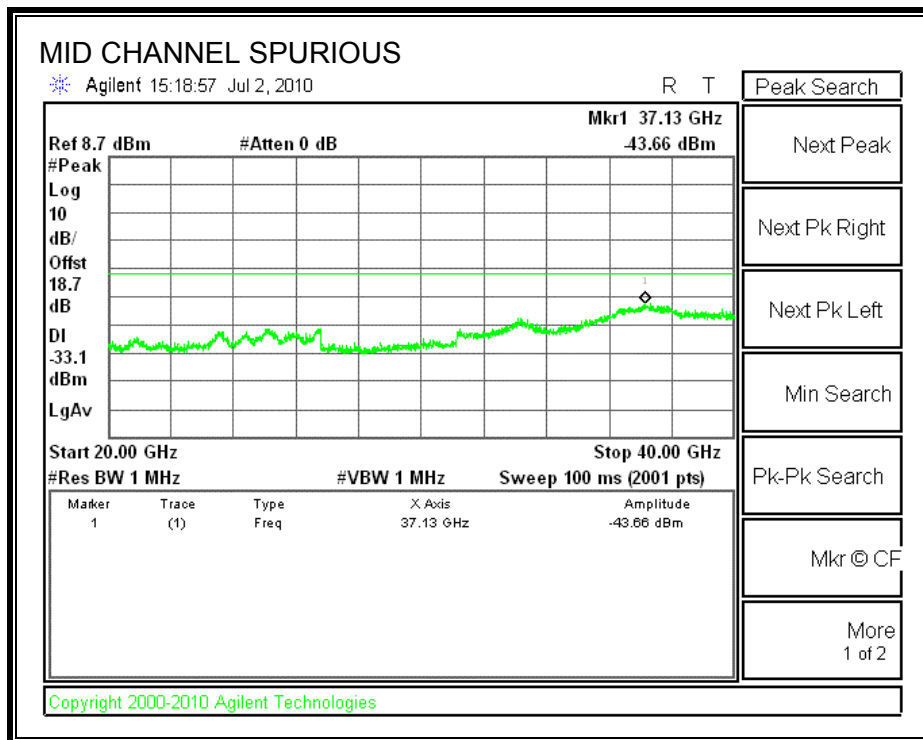
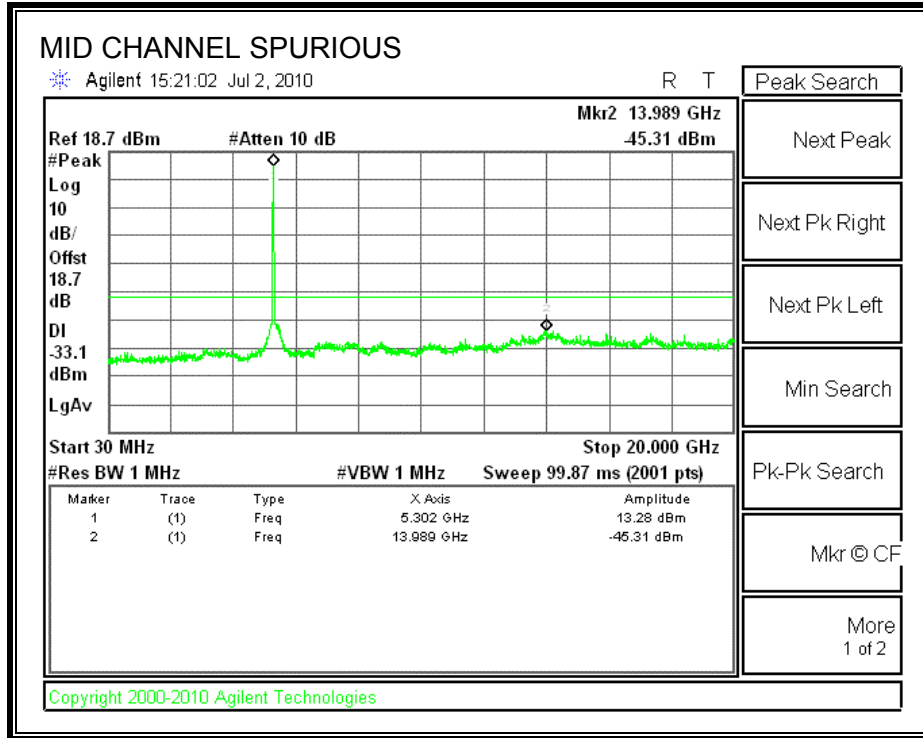



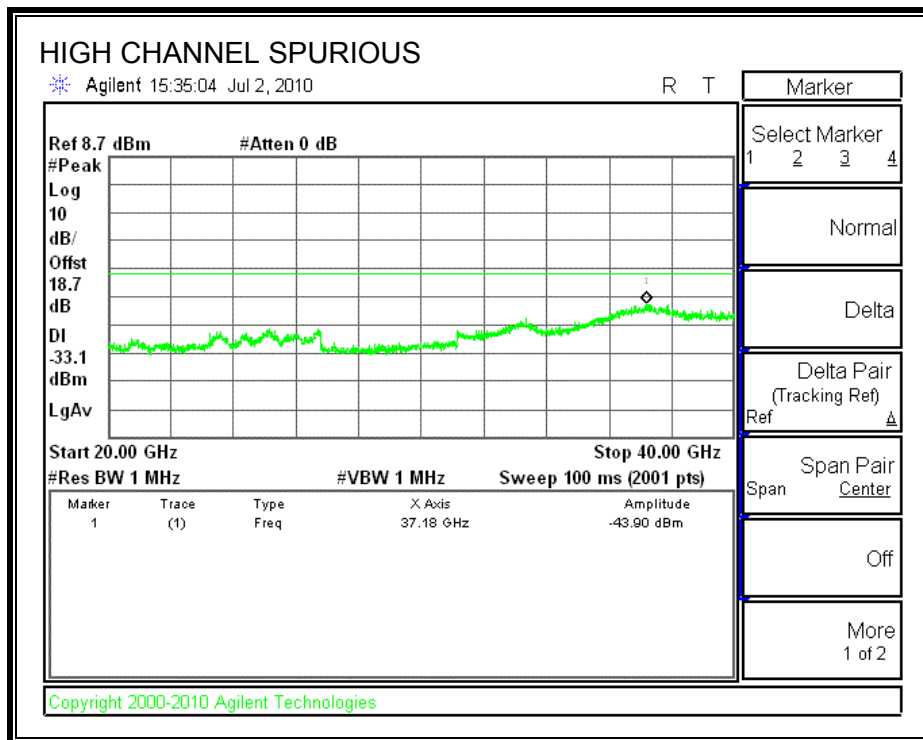
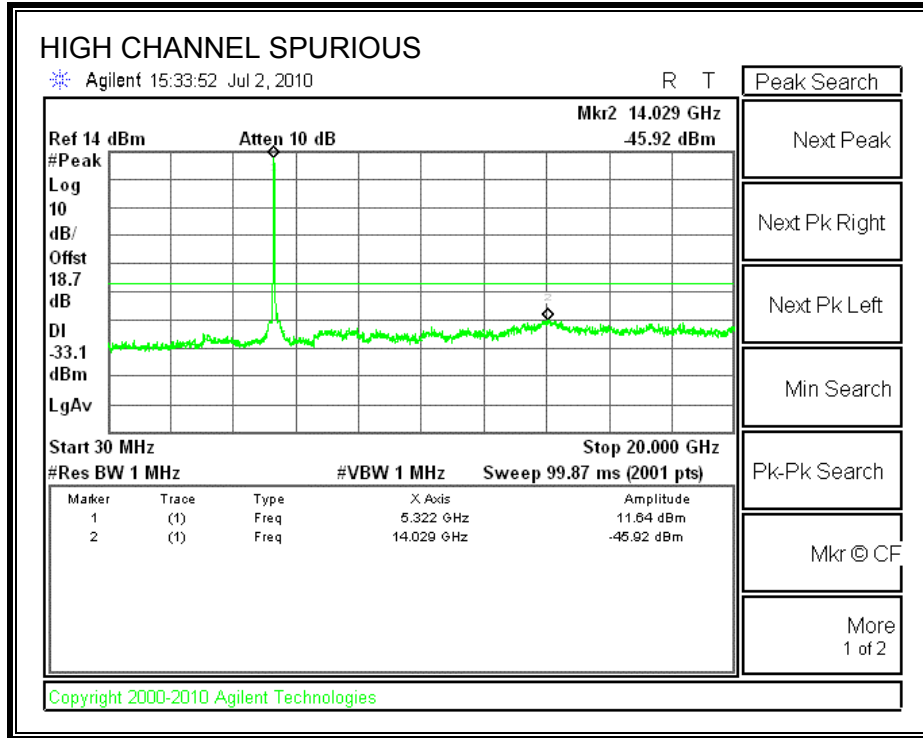

## 7.6. 802.11n HT20 MODE IN THE 5.3 GHz BAND

### 7.6.1. 26 dB and 99% BANDWIDTH

#### LIMITS

None; for reporting purposes only.

#### TEST PROCEDURE

The transmitter outputs are connected to the spectrum analyzer via a combiner. The RBW is set to 1% to 3% of the measured bandwidth. The VBW is set to 3 times the RBW. The sweep time is coupled. The spectrum analyzer internal bandwidth function is utilized.

#### RESULTS

##### CHAIN 0

Channel	Frequency (MHz)	26 dB Bandwidth (MHz)	99% Bandwidth (MHz)
Low	5260	21.972	17.6249
Middle	5300	19.651	17.5902
High	5320	19.527	17.5532

##### CHAIN 1

Channel	Frequency (MHz)	26 dB Bandwidth (MHz)	99% Bandwidth (MHz)
Low	5260	20.086	17.6498
Middle	5300	21.606	17.6439
High	5320	18.918	17.6242

**CHAIN 0**

**26 dB and 99% BANDWIDTH**

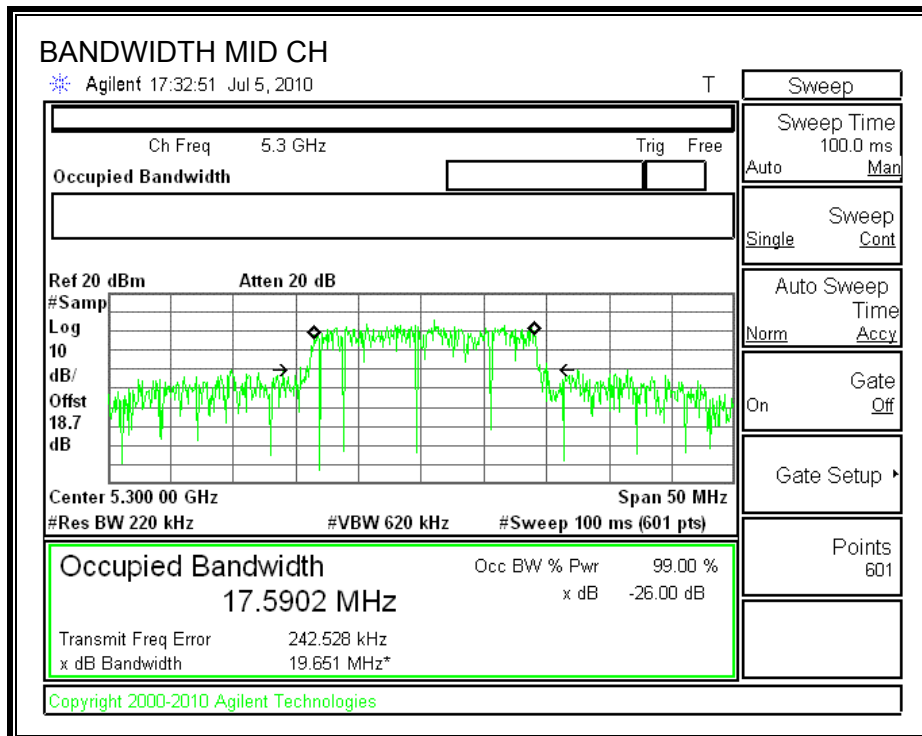
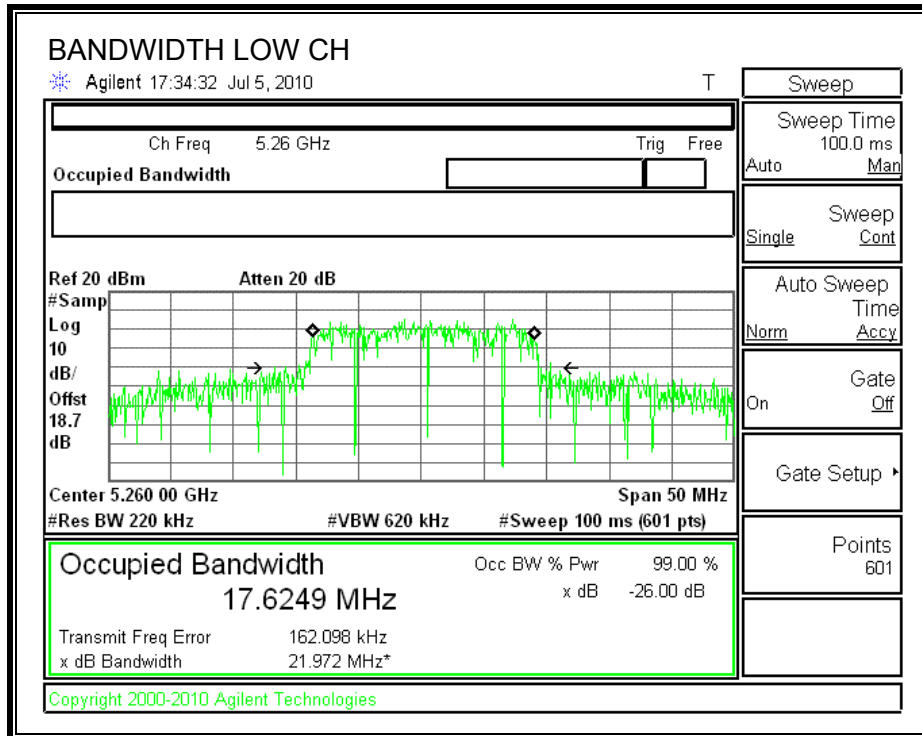

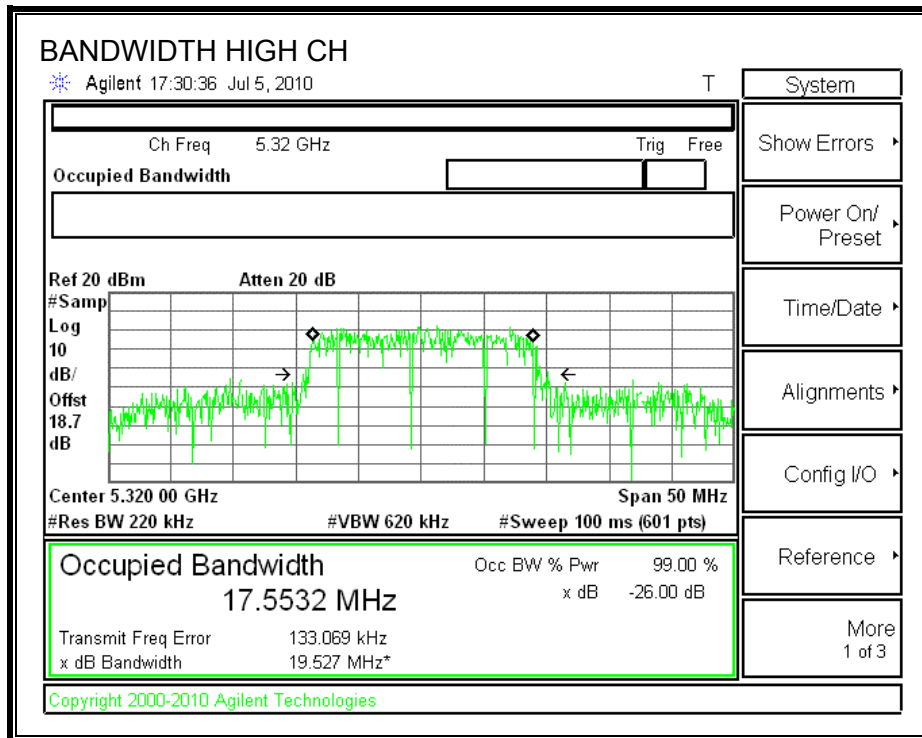

**CHAIN 1**

**26 dB and 99% BANDWIDTH**

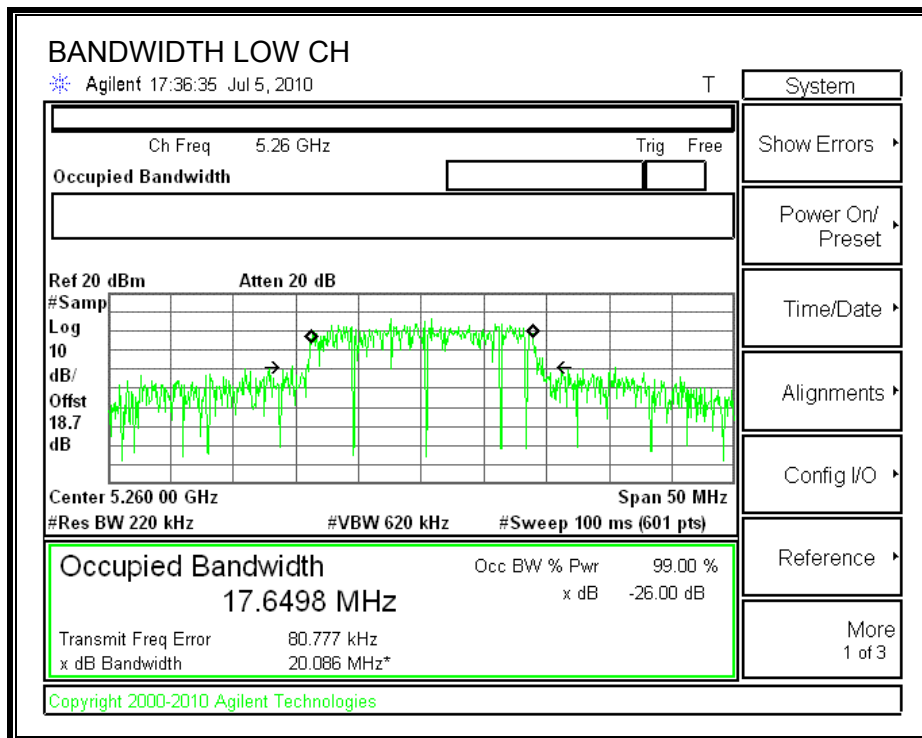

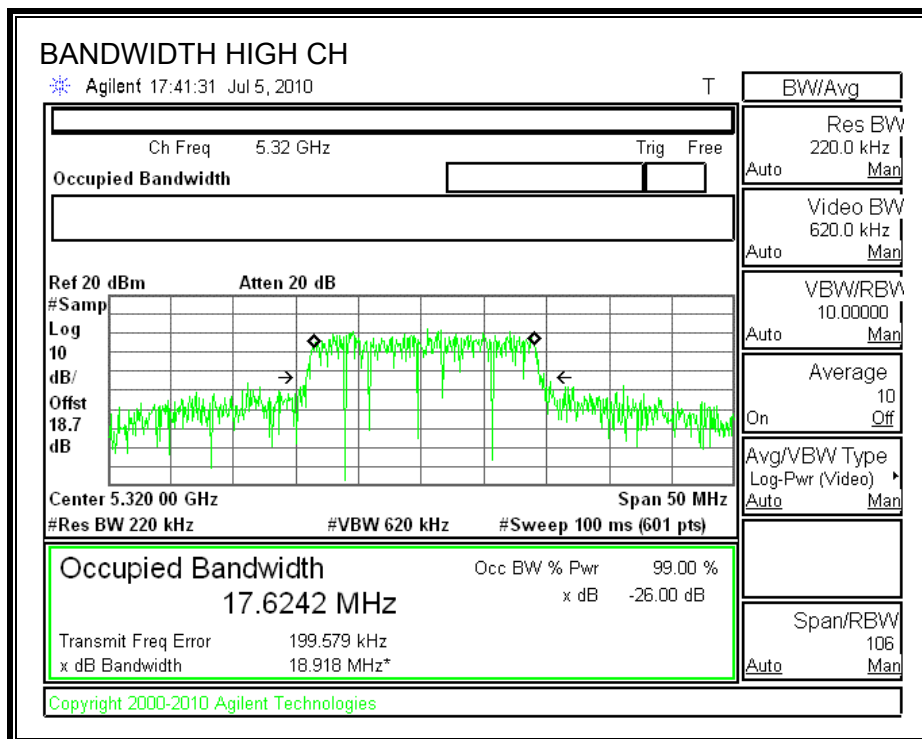
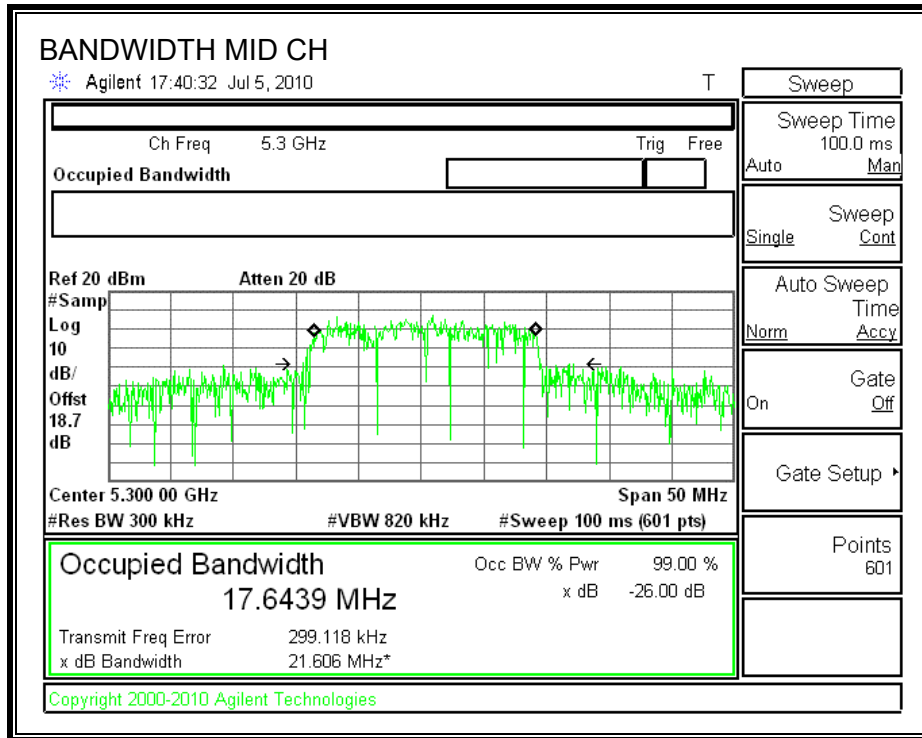

## 7.6.2. OUTPUT POWER

### LIMITS

FCC §15.407 (a) (2)

IC RSS-210 A9.2 (2)

For the 5.25-5.35 GHz band, the maximum conducted output power over the frequency band of operation shall not exceed the lesser of 250 mW or  $11 \text{ dBm} + 10 \log B$ , where B is the 26-dB emission bandwidth in MHz. If transmitting antennas of directional gain greater than 6 dBi are used, both the peak transmit power and the peak power spectral density shall be reduced by the amount in dB that the directional gain of the antenna exceeds 6 dBi.

The composite antenna gain is 8.86 dBi.

### TEST PROCEDURE

The test is performed in accordance with FCC Public Notice: APPENDIX A Guidelines for Assessing Unlicensed National Information Infrastructure (U-NII) Devices – Part 15, Subpart E, August 2002.

The transmitter output operates continuously therefore Method # 1 is used.

**RESULTS**

**Limit**

Channel	Frequency (MHz)	Fixed Limit (dBm)	B (MHz)	11 + 10 Log B Limit (dBm)	Antenna Gain (dBi)	Limit (dBm)
Low	5260	24	21.972	24.42	8.86	21.14
Mid	5300	24	19.651	23.93	8.86	21.07
High	5320	24	19.527	23.91	8.86	21.05

**Individual Chain Results**

Channel	Frequency (MHz)	Chain 0 Power (dBm)	Chain 1 Power (dBm)	Total Power (dBm)	Limit (dBm)	Margin (dB)
Low	5260	13.23	13.17	16.21	21.14	-4.93
Mid	5300	13.35	13.07	16.22	21.07	-4.85
High	5320	13.29	13.04	16.18	21.05	-4.87

**CHAIN 0 OUTPUT POWER**

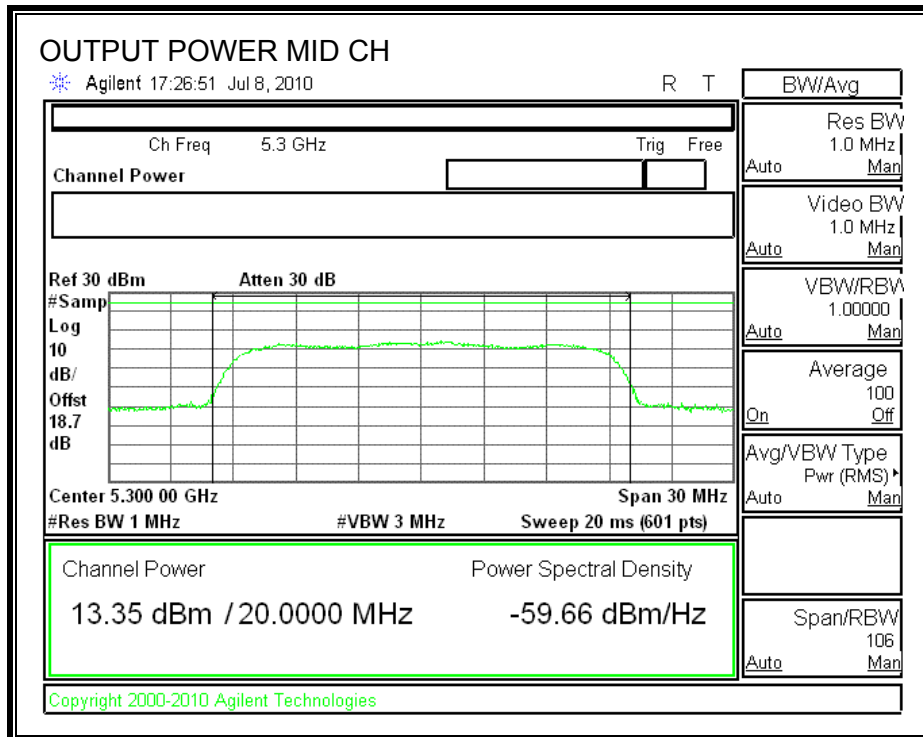
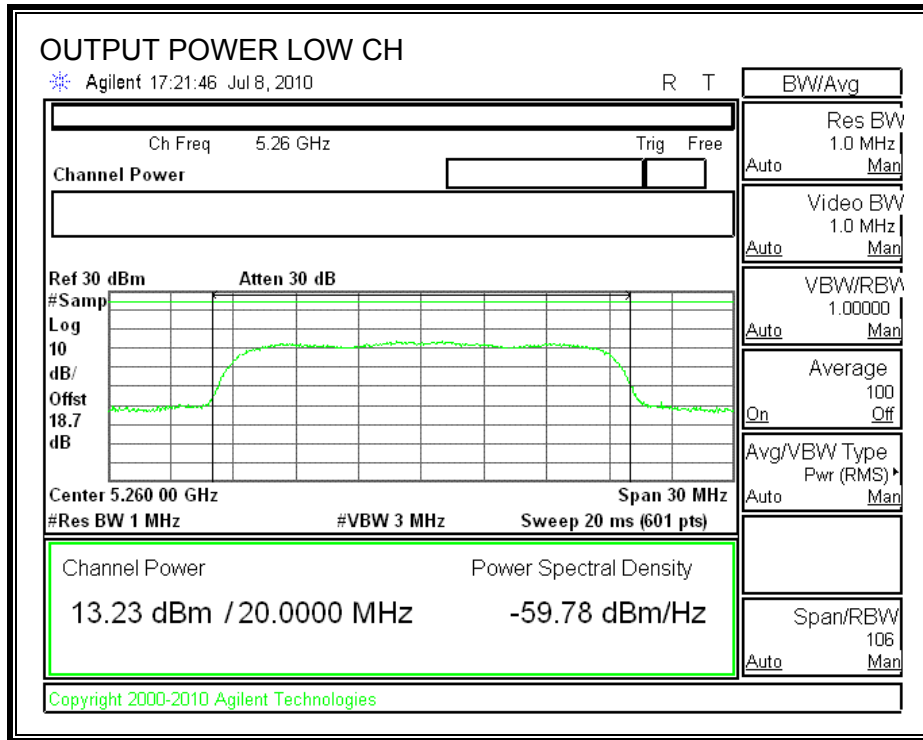



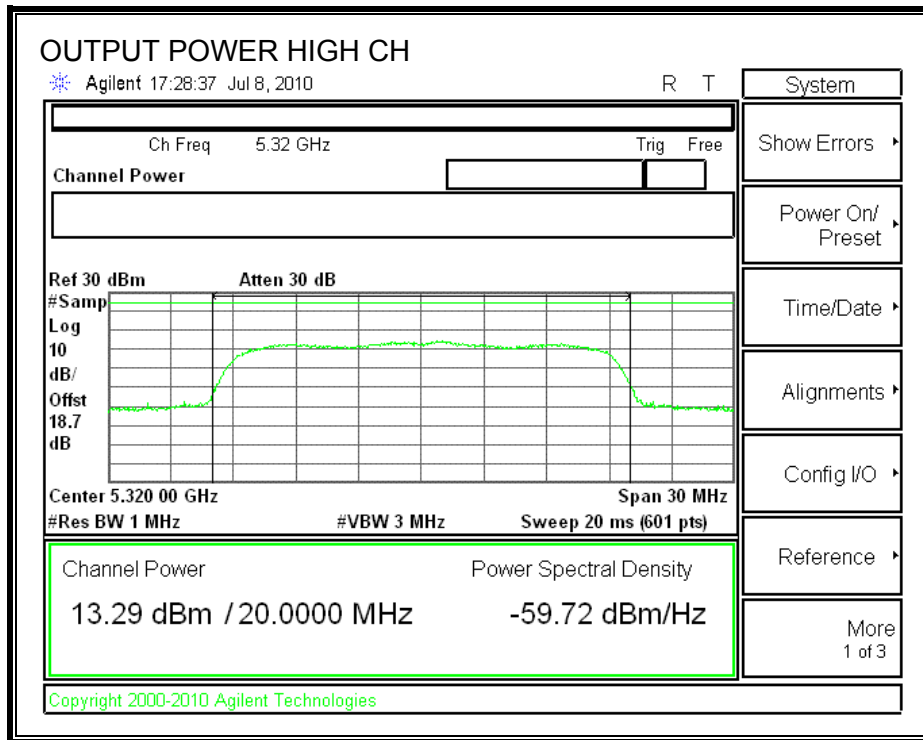

**CHAIN 1 OUTPUT POWER**

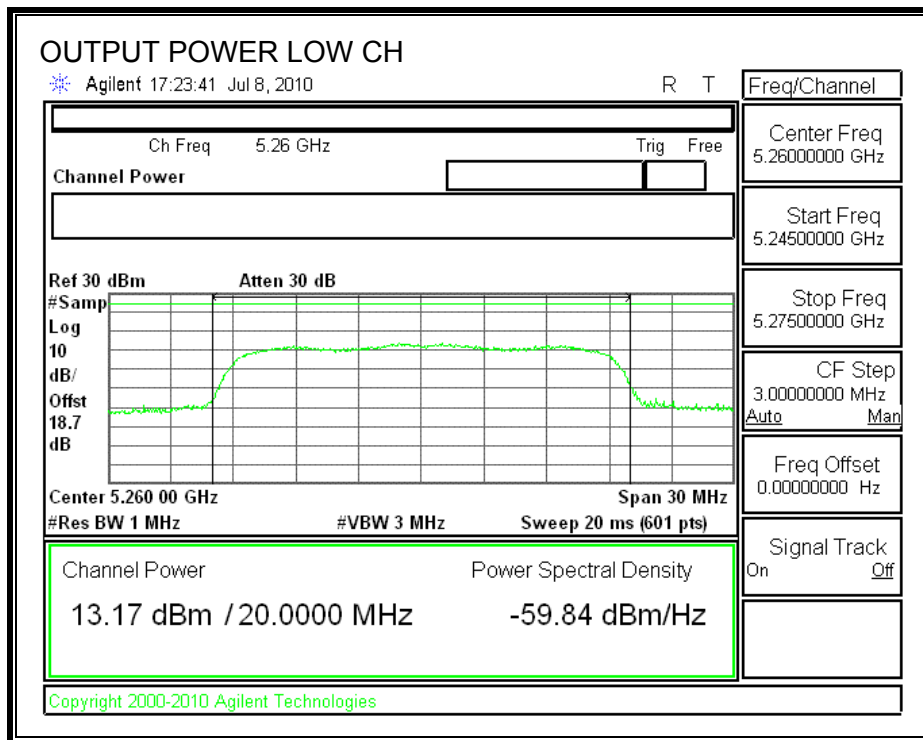

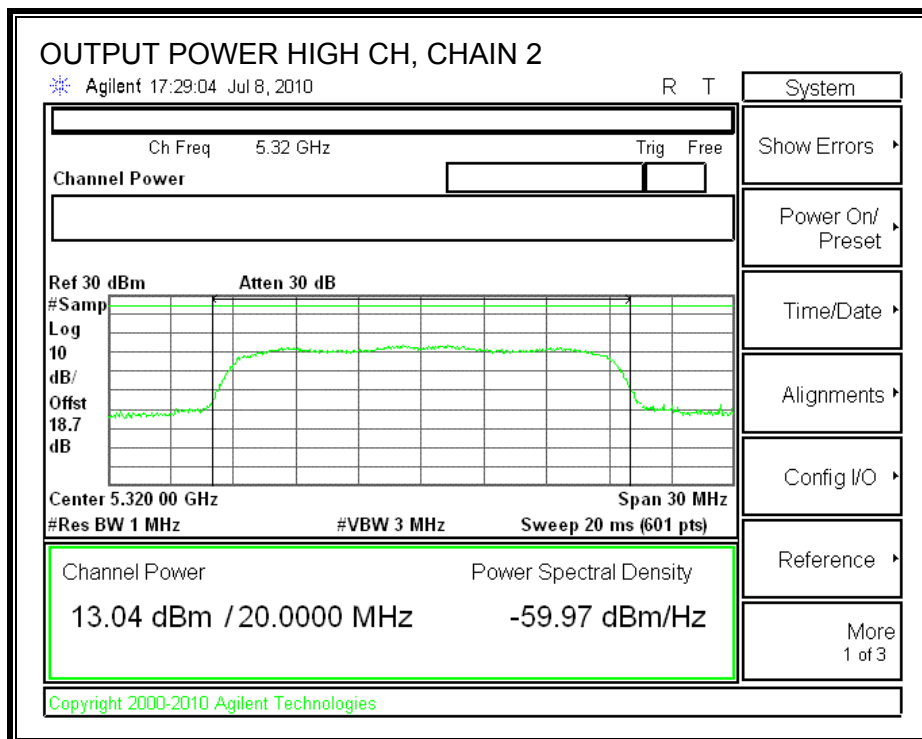
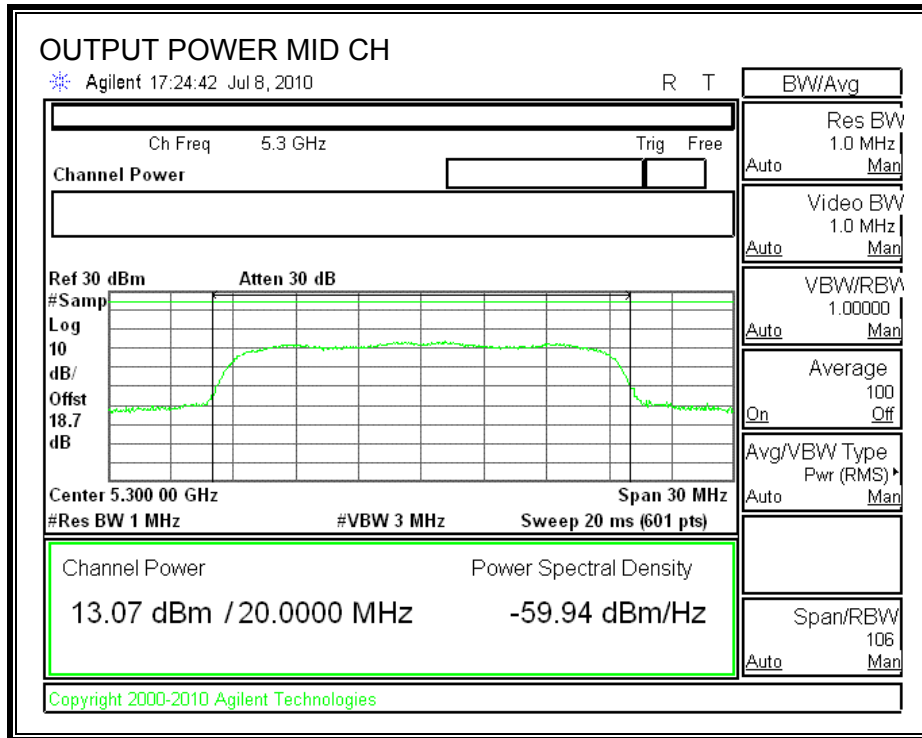

### 7.6.3. PEAK POWER SPECTRAL DENSITY

#### LIMITS

FCC §15.407 (a) (2)

IC RSS-210 A9.2 (2)

For the 5.25-5.35 GHz band, the peak power spectral density shall not exceed 11 dBm in any 1 MHz band. If transmitting antennas of directional gain greater than 6 dBi are used, both the peak transmit power and the peak power spectral density shall be reduced by the amount in dB that the directional gain of the antenna exceeds 6 dBi.

The composite antenna gain is equal to 8.86 dBi, therefore the limit is 8.14 dBm.

#### TEST PROCEDURE

The test is performed in accordance with FCC Public Notice: APPENDIX A Guidelines for Assessing Unlicensed National Information Infrastructure (U-NII) Devices – Part 15, Subpart E, August 2002. PPSD method #2 was used.

#### RESULTS

Channel	Frequency (MHz)	PPSD With Combiner (dBm)	Limit (dBm)	Margin (dB)
Low	5260	7.96	8.14	-0.18
Middle	5300	7.94	8.14	-0.20
High	5320	7.95	8.14	-0.19

**POWER SPECTRAL DENSITY WITH COMBINER**

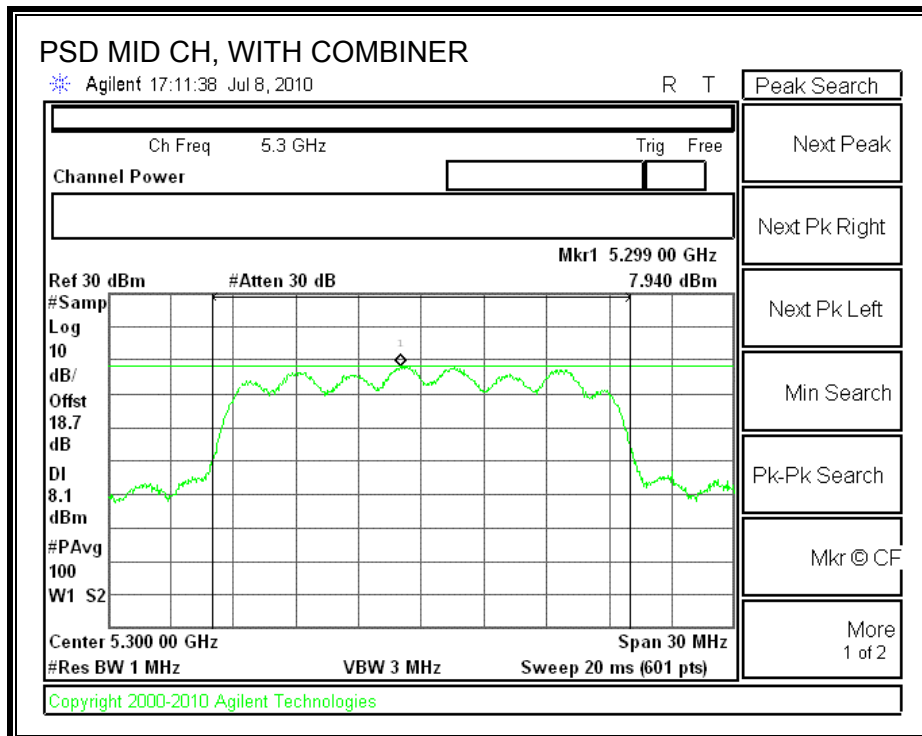
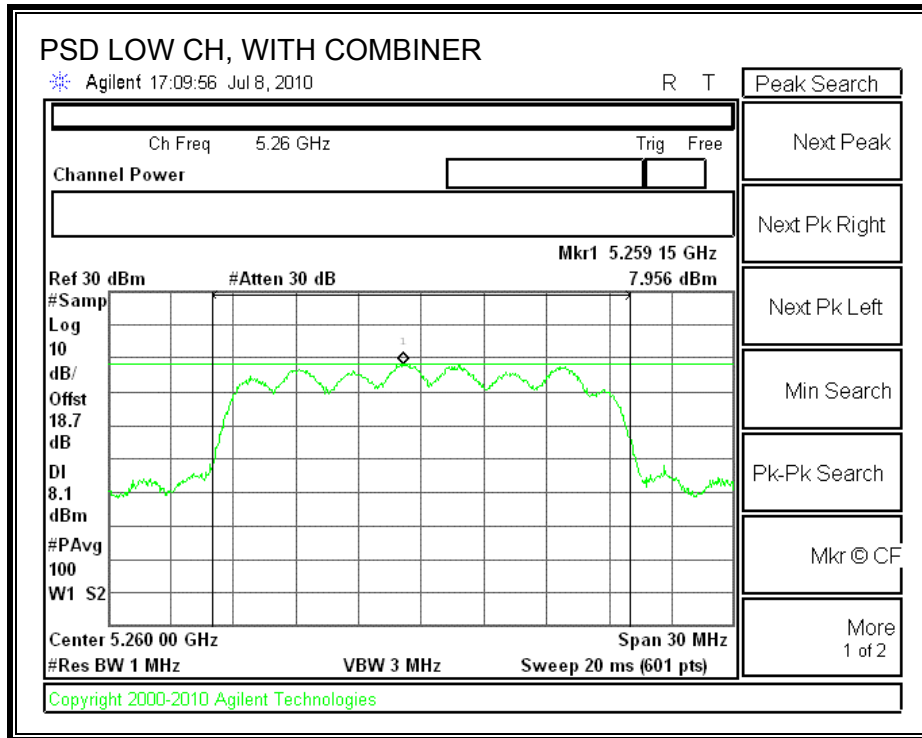

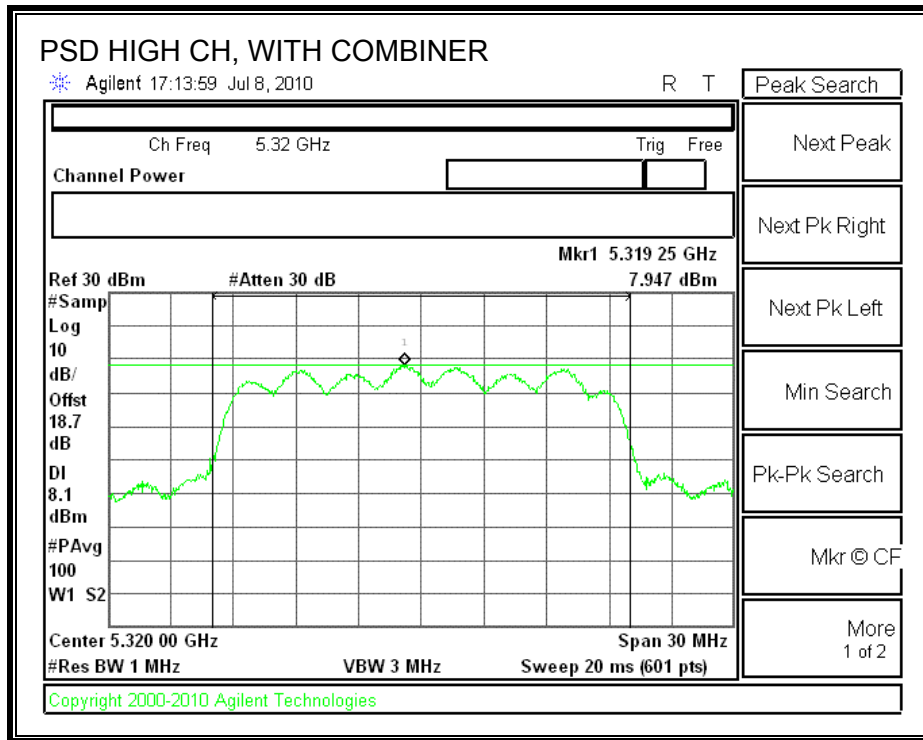

### 7.6.4. PEAK EXCURSION

#### LIMITS

FCC §15.407 (a) (6)

The ratio of the peak excursion of the modulation envelope (measured using a peak hold function) to the peak transmit power (measured as specified above) shall not exceed 13 dB across any 1 MHz bandwidth or the emission bandwidth whichever is less.

#### TEST PROCEDURE

The transmitter outputs are connected to the spectrum analyzer via a combiner.

The test is performed in accordance with FCC Public Notice: APPENDIX A Guidelines for Assessing Unlicensed National Information Infrastructure (U-NII) Devices – Part 15, Subpart E, August 2002.

Since Method # 1 was used for peak power measurements, Method # 1 settings are used for the second PPSD trace.

#### RESULTS

##### CHAIN 0

Channel	Frequency (MHz)	Peak Excursion (dB)	Limit (dB)	Margin (dB)
Low	5260	9.15	13	-3.85
Middle	5300	8.69	13	-4.31
High	5320	9.55	13	-3.45

##### CHAIN 1

Channel	Frequency (MHz)	Peak Excursion (dB)	Limit (dB)	Margin (dB)
Low	5260	8.84	13	-4.16
Middle	5300	10.34	13	-2.66
High	5320	9.78	13	-3.22

**CHAIN 0**

**PEAK EXCURSION**

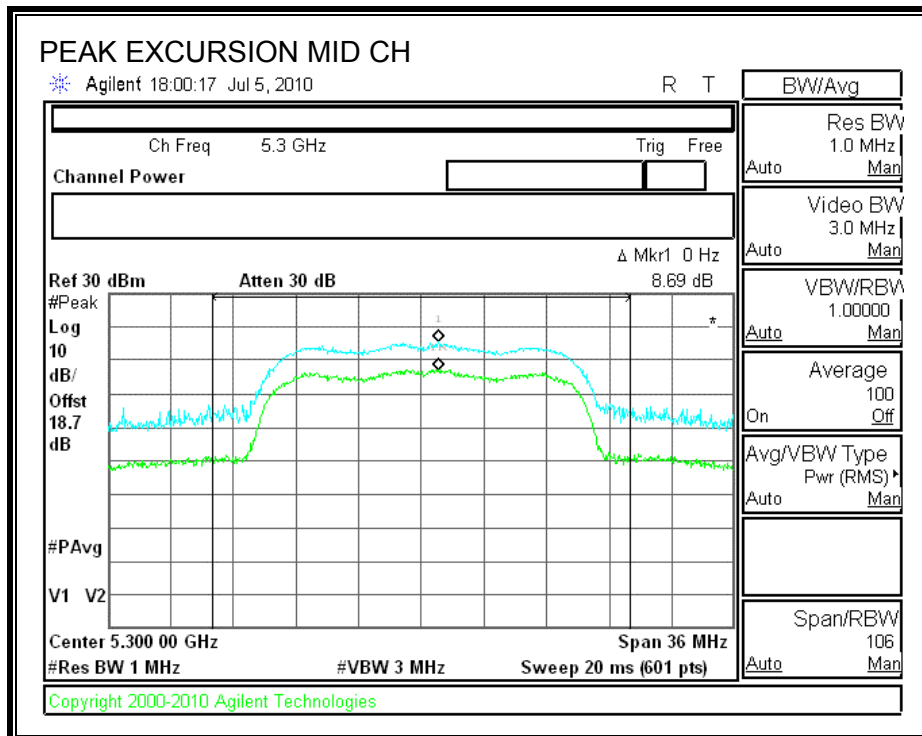
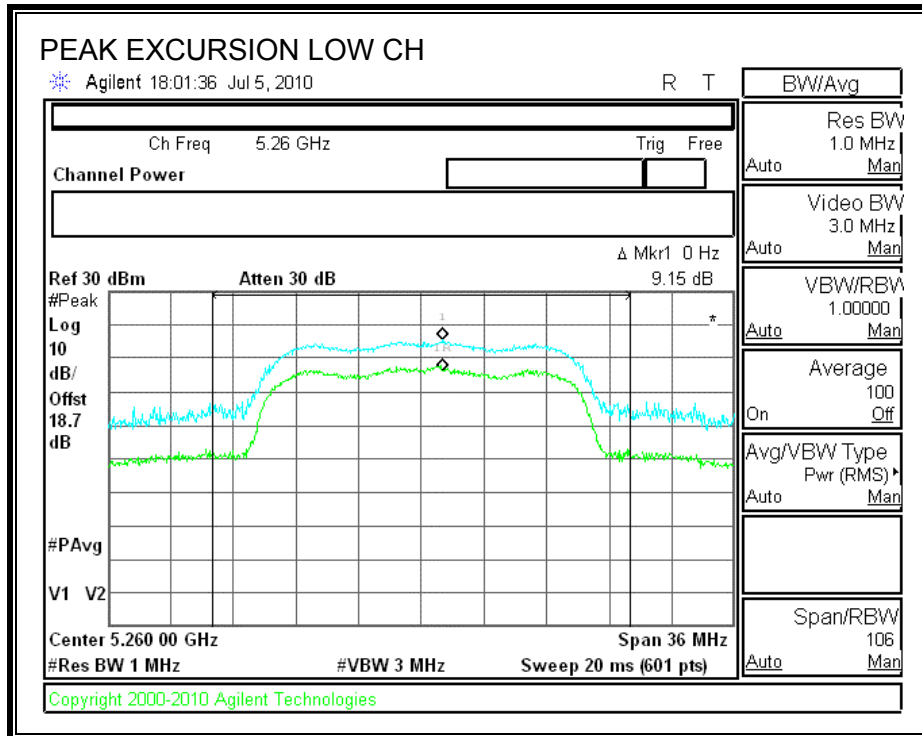

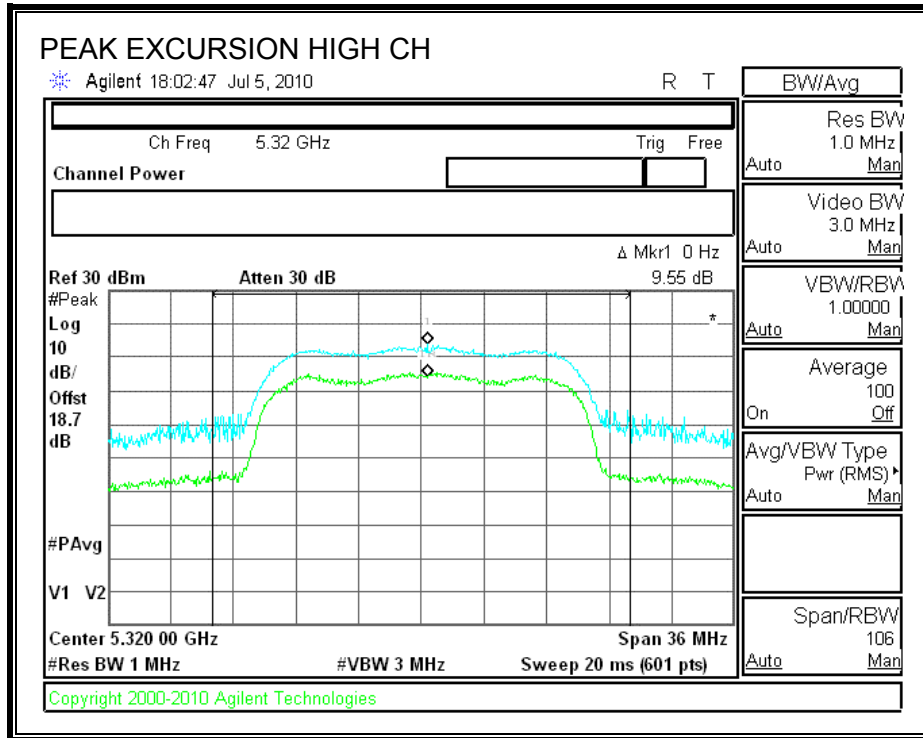

**CHAIN 1**

**PEAK EXCURSION**

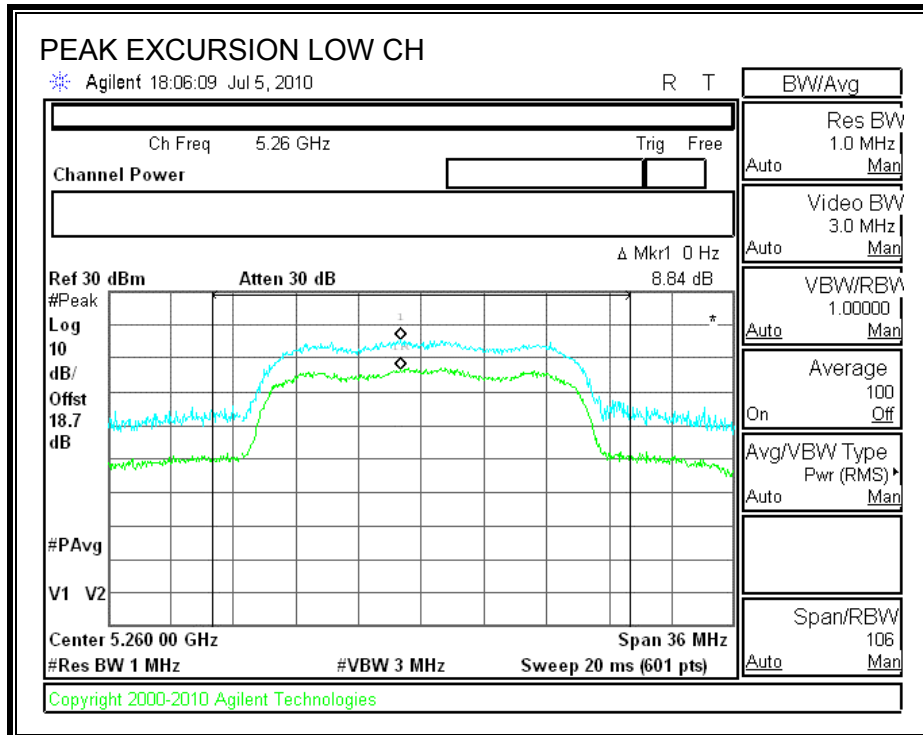



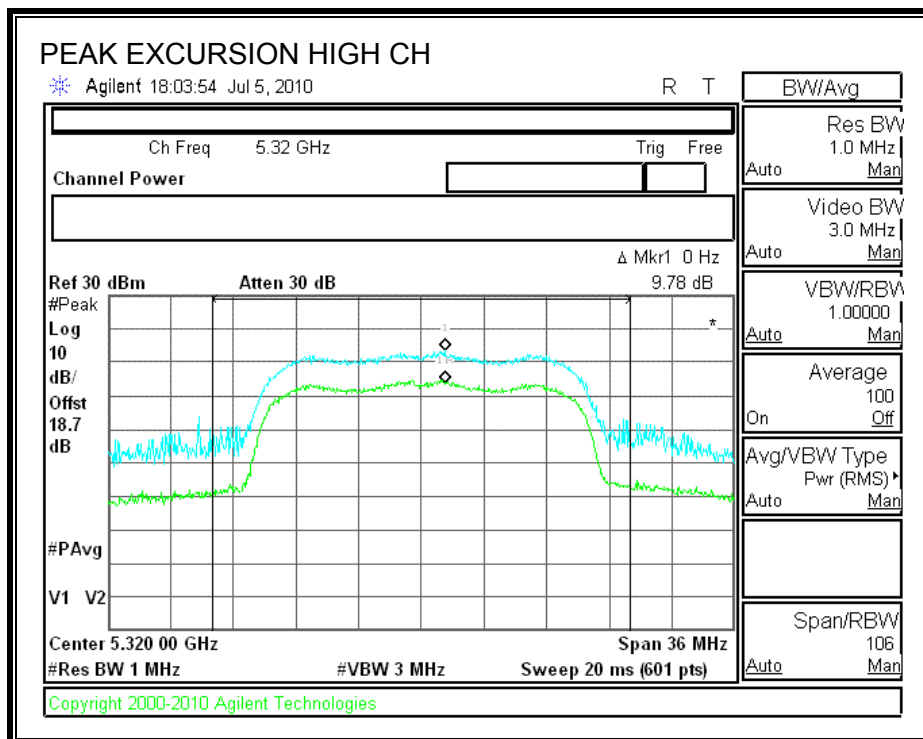
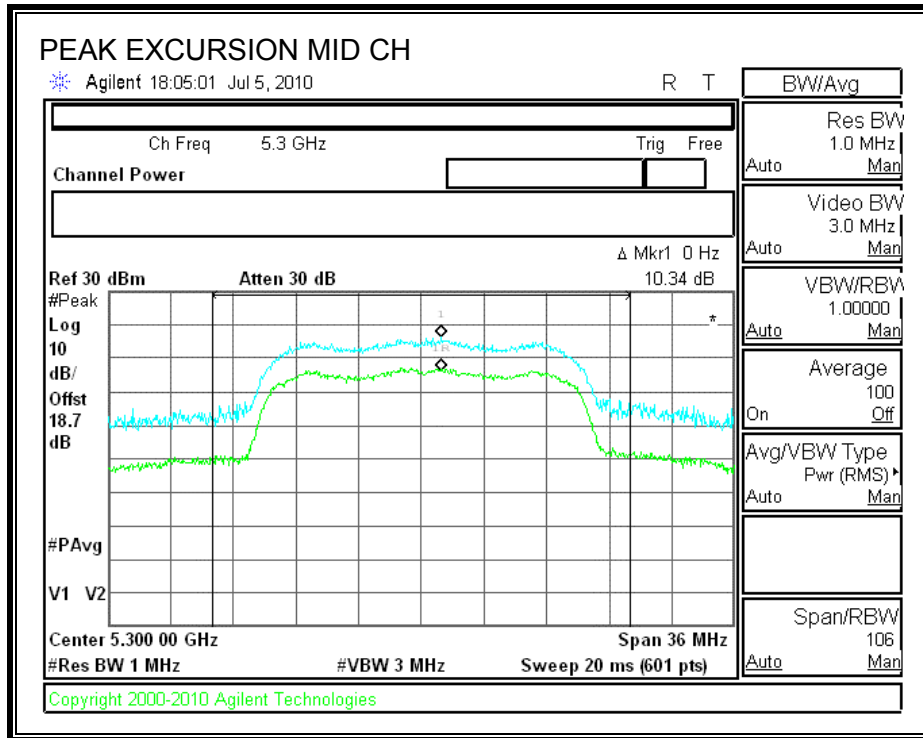

## 7.6.5. CONDUCTED SPURIOUS EMISSIONS

### LIMITS

FCC §15.407 (b) (2)

IC RSS-210 A9.3 (2)

For transmitters operating in the 5.25-5.35 GHz band: all emissions outside of the 5.25-5.35 GHz band shall not exceed an EIRP of -27 dBm / MHz.

Devices operating in the 5.25-5.35 GHz band that generate emissions in the 5.15-5.25 GHz band must meet all applicable technical requirements for operation in the 5.15-5.25 GHz band (including indoor use) or alternatively meet an out-of-band emission EIRP limit of -27 dBm/MHz in the 5.15-5.25 GHz band.

### TEST PROCEDURE

Conducted RF measurements of the transmitter output are made to confirm that the EUT antenna port conducted emissions meet the specified limit and to identify any spurious signals that require further investigation or measurements on the radiated emissions site.

The transmitter output is connected to the spectrum analyzer. The resolution bandwidth is set to 1 MHz. The video bandwidth is set to 1MHz. Peak detection measurements are compared to EIRP limit, adjusted for the maximum antenna gain.

Measurements are made over the 30 MHz to 40 GHz range with the transmitter set to the lowest, middle, and highest channels.

**SPURIOUS EMISSIONS WITH COMBINER**

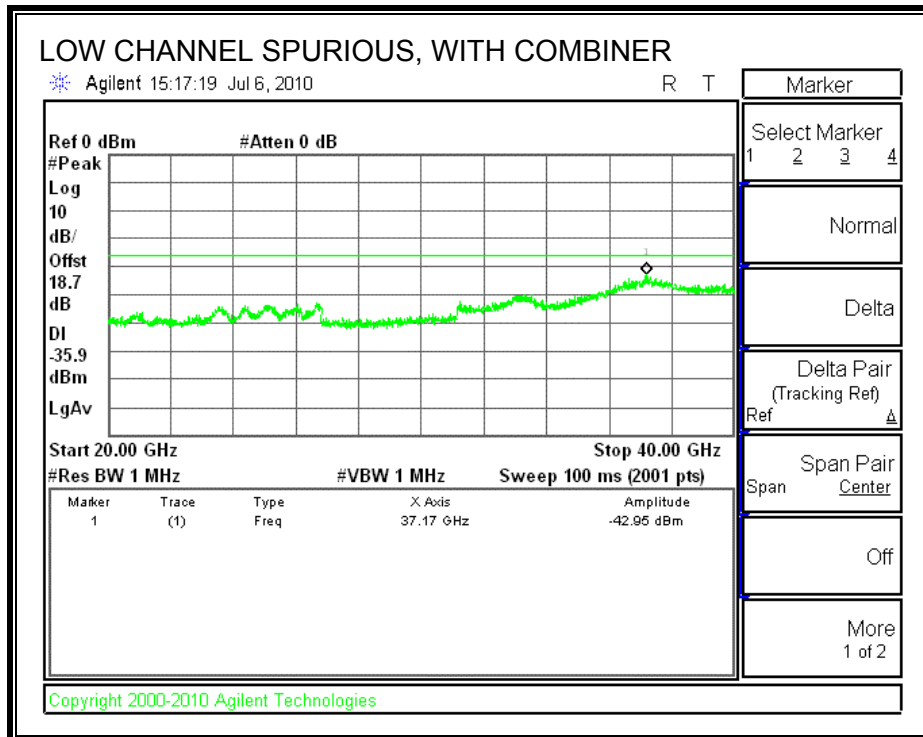
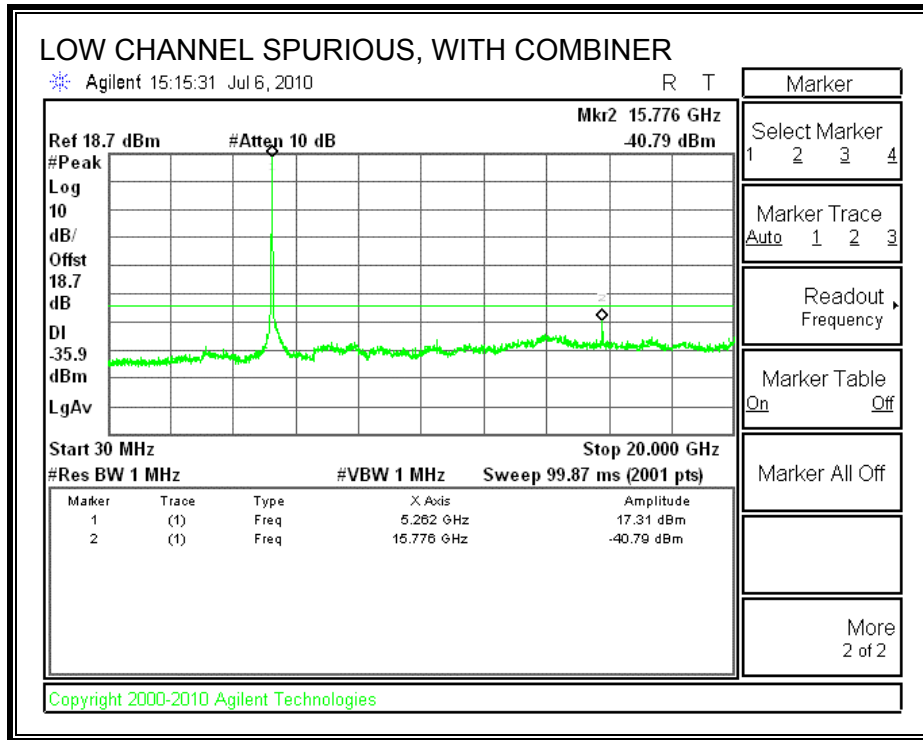

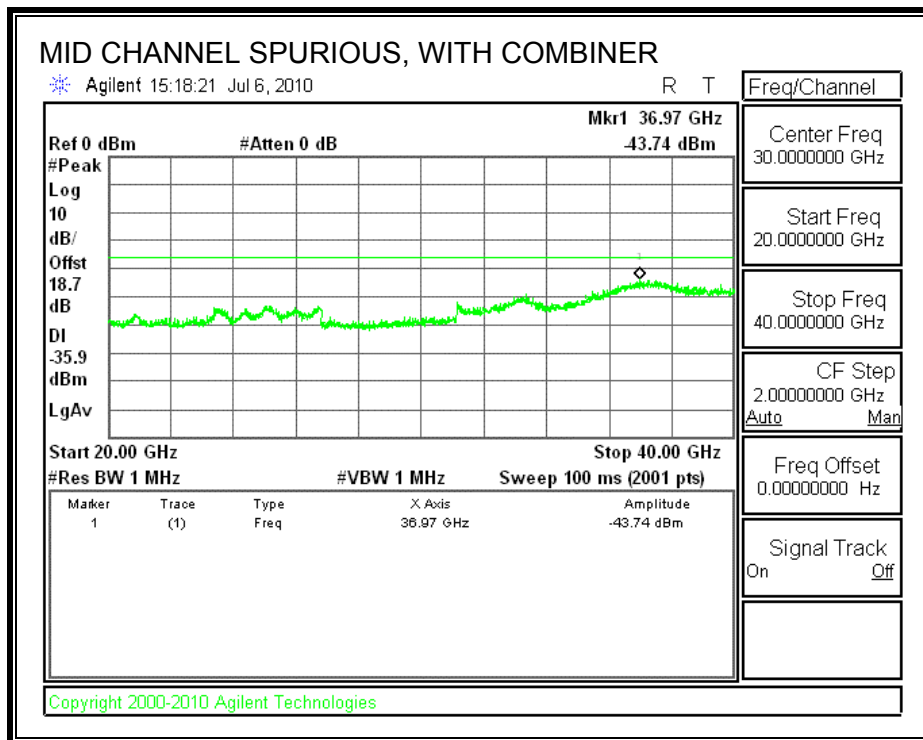
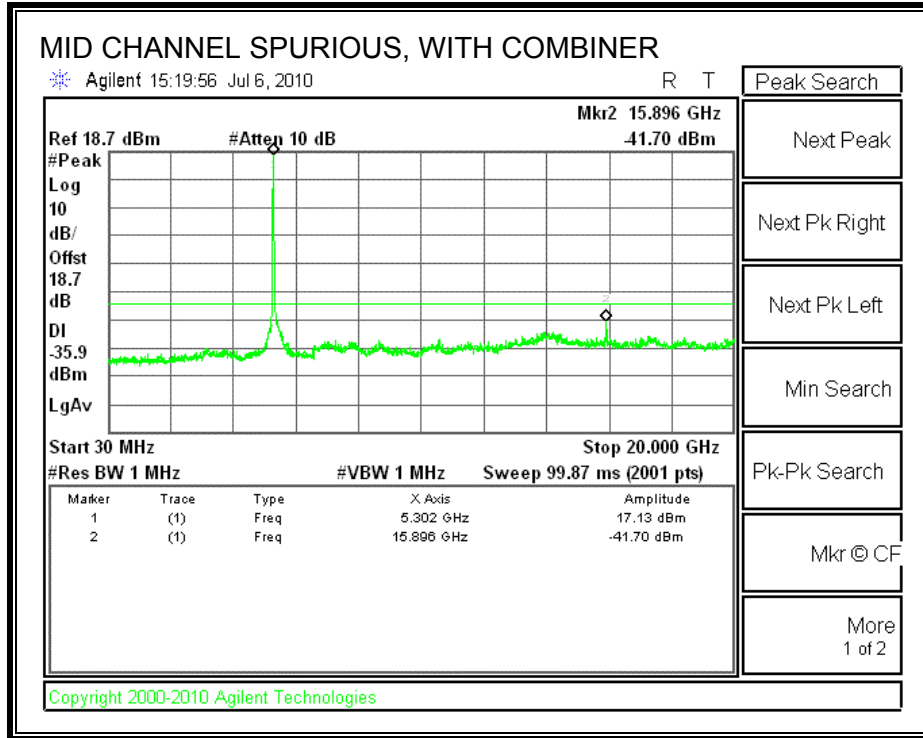

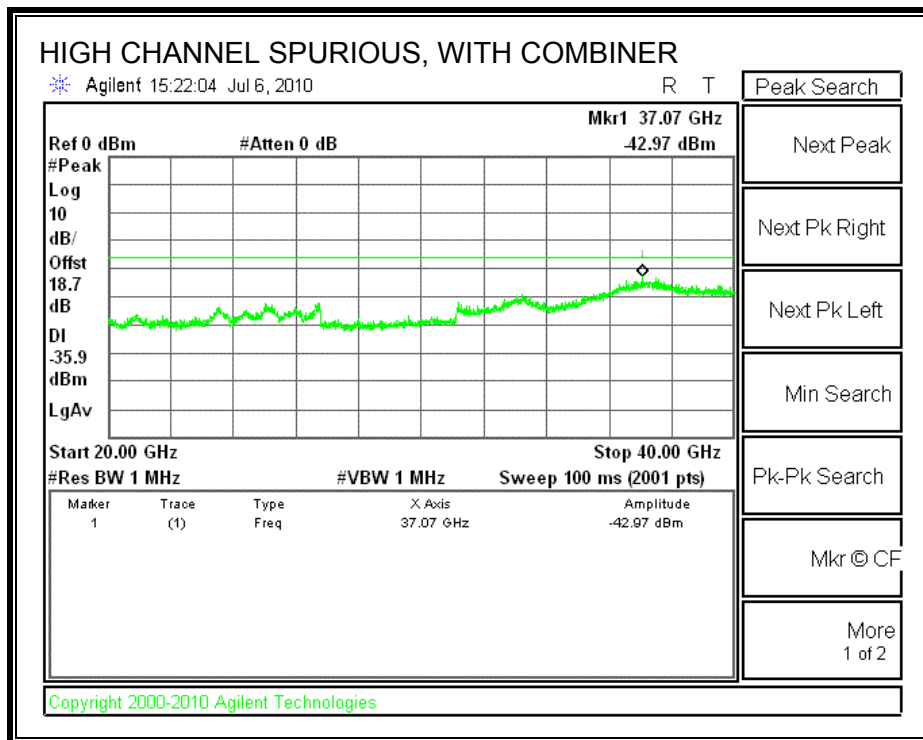
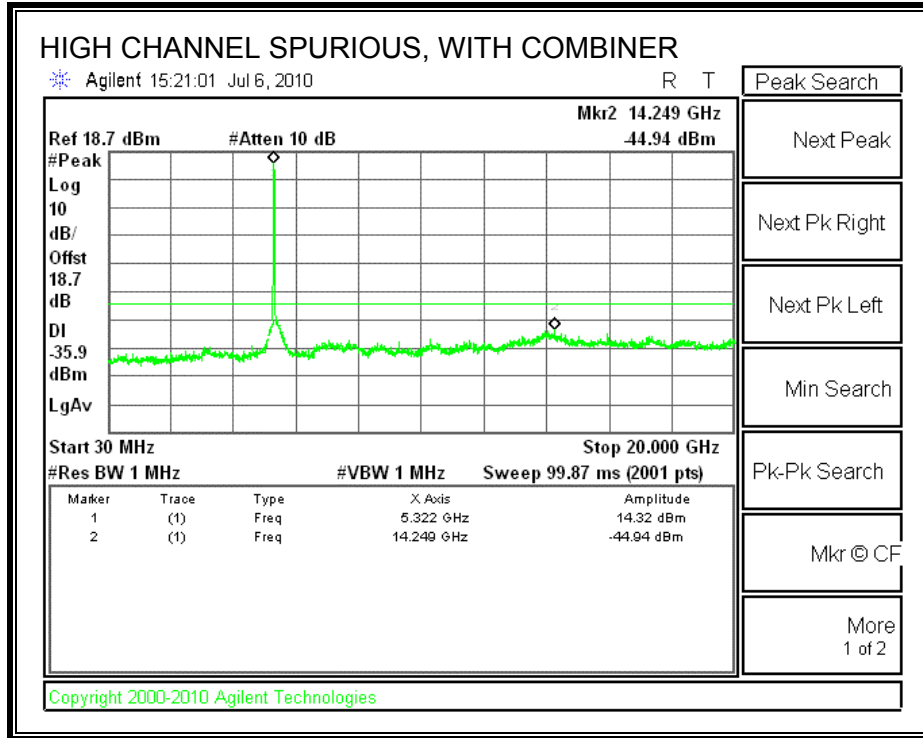

## 7.7. 802.11n HT40 SISO MODE IN THE 5.3 GHz BAND

### 7.7.1. 26 dB and 99% BANDWIDTH

#### LIMITS

None; for reporting purposes only.

#### TEST PROCEDURE

The transmitter outputs are connected to the spectrum analyzer via a combiner. The RBW is set to 1% to 3% of the measured bandwidth. The VBW is set to 3 times the RBW. The sweep time is coupled. The spectrum analyzer internal bandwidth function is utilized.

#### RESULTS

##### CHAIN 2

Channel	Frequency (MHz)	26 dB Bandwidth (MHz)	99% Bandwidth (MHz)
Low	5270	72.783	38.668
High	5310	36.340	39.242

**26 dB and 99% BANDWIDTH**

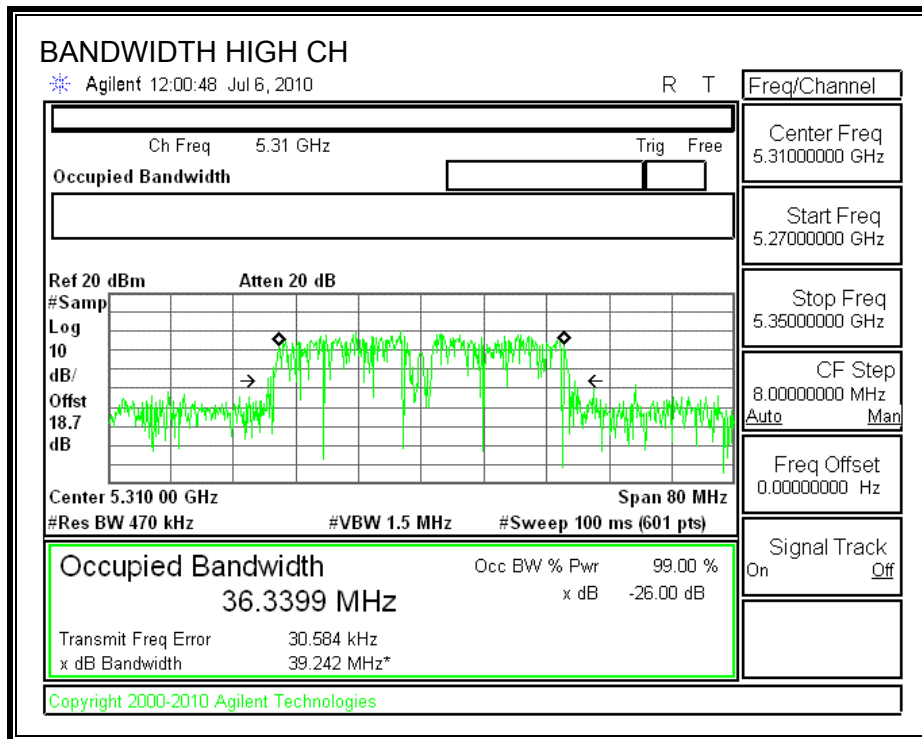
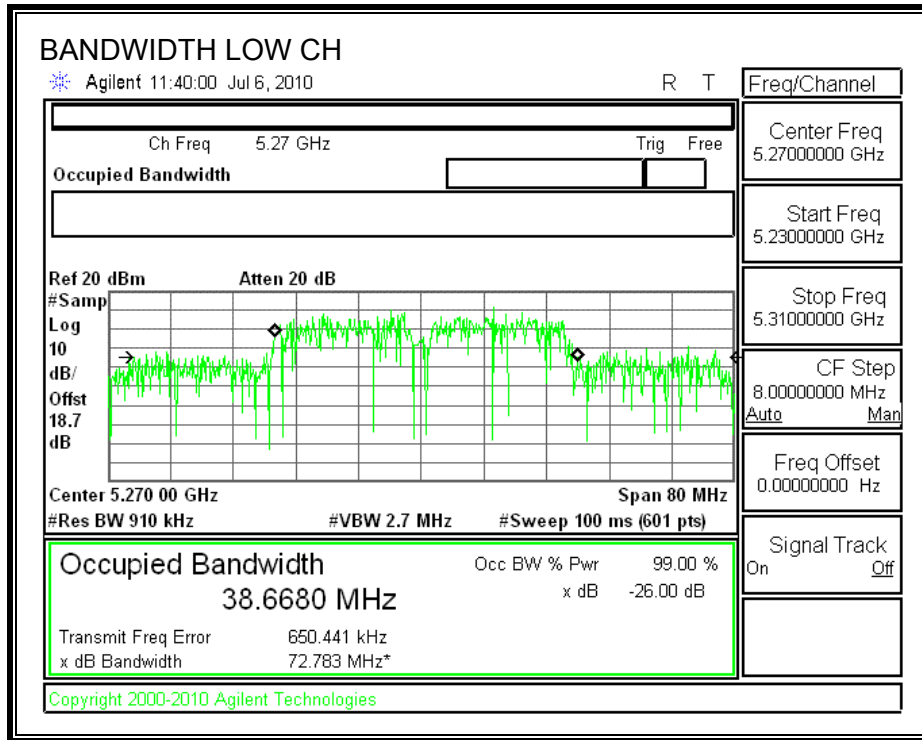

## 7.7.2. OUTPUT POWER

### LIMITS

FCC §15.407 (a) (1)

IC RSS-210 A9.2 (1)

For the 5.25-5.35 GHz band, the maximum conducted output power over the frequency band of operation shall not exceed the lesser of 250 mW or  $11 \text{ dBm} + 10 \log B$ , where B is the 26-dB emission bandwidth in MHz. If transmitting antennas of directional gain greater than 6 dBi are used, both the peak transmit power and the peak power spectral density shall be reduced by the amount in dB that the directional gain of the antenna exceeds 6 dBi.

The maximum antenna gain is 6.12 dBi.

### TEST PROCEDURE

The test is performed in accordance with FCC Public Notice: APPENDIX A Guidelines for Assessing Unlicensed National Information Infrastructure (U-NII) Devices – Part 15, Subpart E, August 2002.

The transmitter output operates continuously therefore Method # 1 is used.

### RESULTS

#### Limit

Channel	Frequency (MHz)	Fixed Limit (dBm)	B (MHz)	11 + 10 Log B Limit (dBm)	Antenna Gain (dBi)	Limit (dBm)
Low	5270	24	72.783	22.62	6.12	22.50
High	5310	24	36.340	19.60	6.12	19.48

#### Results

Channel	Frequency (MHz)	Power (dBm)	Limit (dBm)	Margin (dB)
Low	5270	16.84	22.50	-5.66
High	5310	11.18	19.48	-8.30



**OUTPUT POWER**

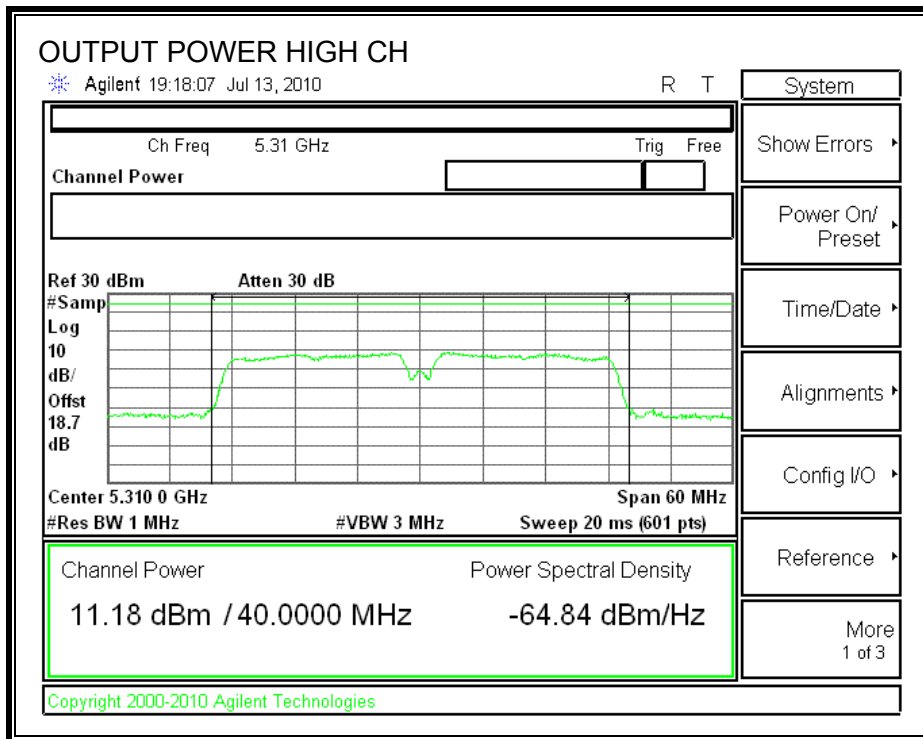
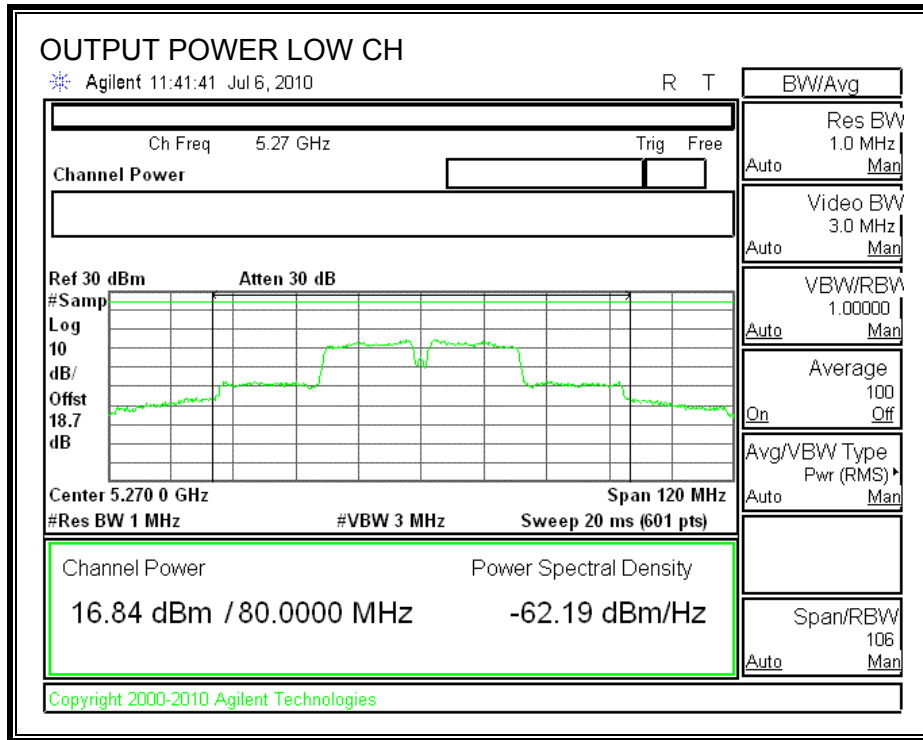

### 7.7.3. PEAK POWER SPECTRAL DENSITY

#### LIMITS

FCC §15.407 (a) (1)

IC RSS-210 A9.2 (1)

For the 5.25-5.35 GHz band, the peak power spectral density shall not exceed 11 dBm in any 1 MHz band. If transmitting antennas of directional gain greater than 6 dBi are used, both the peak transmit power and the peak power spectral density shall be reduced by the amount in dB that the directional gain of the antenna exceeds 6 dBi.

The composite antenna gain is 6.12 dBi, therefore the limit is 10.88 dBm.

#### TEST PROCEDURE

The test is performed in accordance with FCC Public Notice: APPENDIX A Guidelines for Assessing Unlicensed National Information Infrastructure (U-NII) Devices – Part 15, Subpart E, August 2002. PPSD method #2 was used.

#### RESULTS

Channel	Frequency (MHz)	PPSD (dBm)	Limit (dBm)	Margin (dB)
Low	5270	4.06	10.88	-6.82
High	5310	-1.48	10.88	-12.36

**POWER SPECTRAL DENSITY**

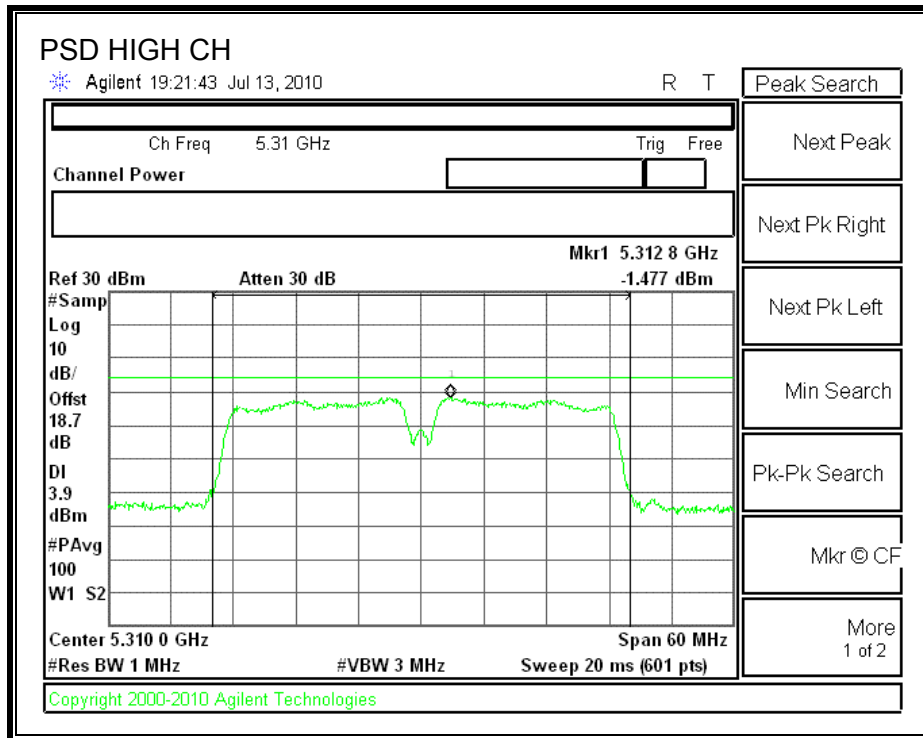
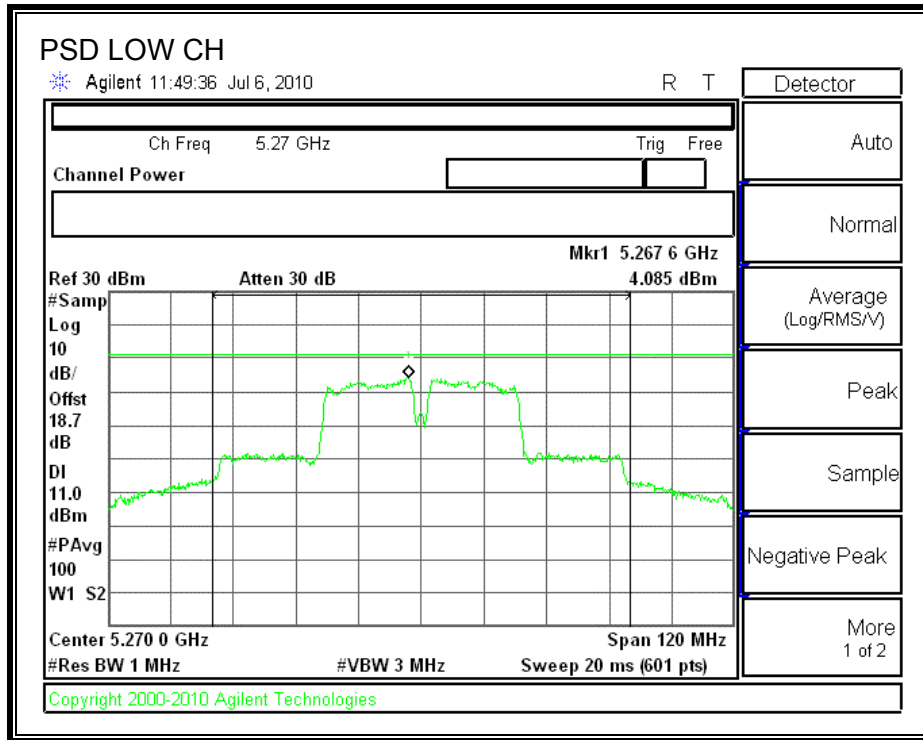

### 7.7.4. PEAK EXCURSION

#### LIMITS

FCC §15.407 (a) (6)

The ratio of the peak excursion of the modulation envelope (measured using a peak hold function) to the peak transmit power (measured as specified above) shall not exceed 13 dB across any 1 MHz bandwidth or the emission bandwidth whichever is less.

#### TEST PROCEDURE

The transmitter outputs are connected to the spectrum analyzer via a combiner.

The test is performed in accordance with FCC Public Notice: APPENDIX A Guidelines for Assessing Unlicensed National Information Infrastructure (U-NII) Devices – Part 15, Subpart E, August 2002.

Since Method # 1 was used for peak power measurements, Method # 1 settings are used for the second PPSD trace.

#### RESULTS

##### CHAIN 1

Channel	Frequency (MHz)	Peak Excursion (dB)	Limit (dB)	Margin (dB)
Low	5190	8.06	13	-4.94
High	5230	8.28	13	-4.72

**PEAK EXCURSION**

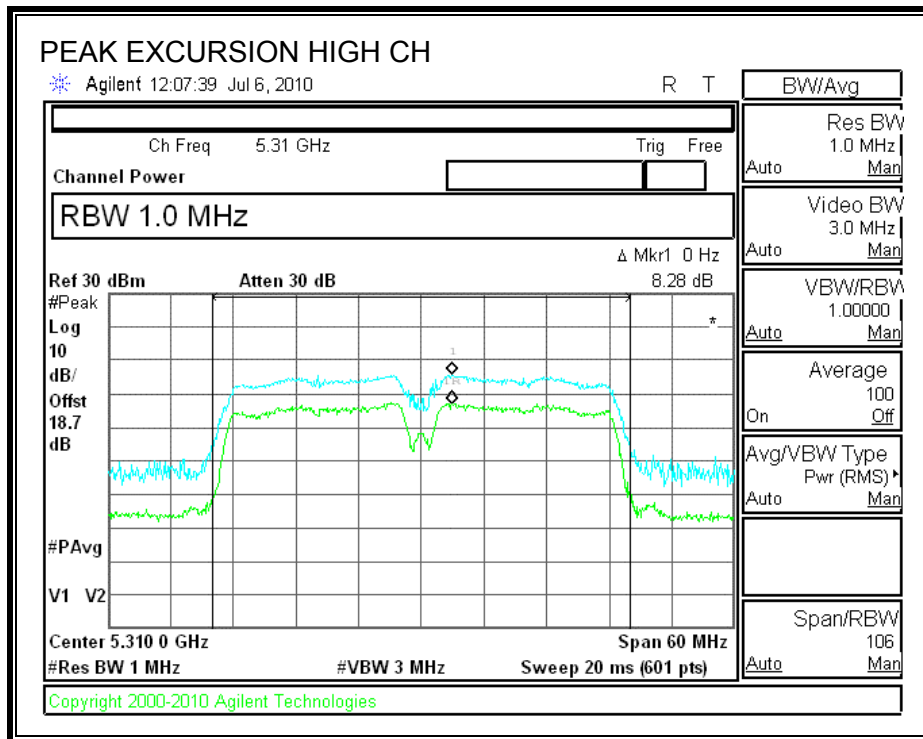
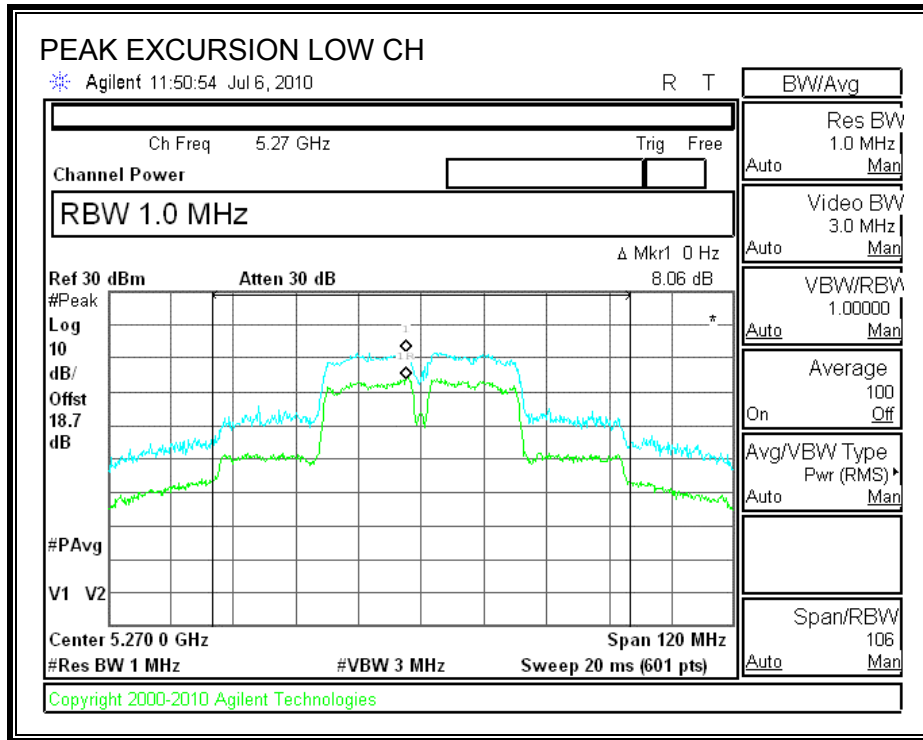

## 7.7.5. CONDUCTED SPURIOUS EMISSIONS

### LIMITS

FCC §15.407 (b) (1)

IC RSS-210 A9.3 (1)

For transmitters operating in the 5.25-5.35 GHz band: all emissions outside of the 5.15-5.35 GHz band shall not exceed an EIRP of -27 dBm / MHz.

### TEST PROCEDURE

Conducted RF measurements of the transmitter output are made to confirm that the EUT antenna port conducted emissions meet the specified limit and to identify any spurious signals that require further investigation or measurements on the radiated emissions site.

The transmitter output is connected to the spectrum analyzer. The resolution bandwidth is set to 1 MHz. The video bandwidth is set to 1MHz. Peak detection measurements are compared to EIRP limit, adjusted for the maximum antenna gain.

Measurements are made over the 30 MHz to 40 GHz range with the transmitter set to the lowest, middle, and highest channels.

**SPURIOUS EMISSIONS**

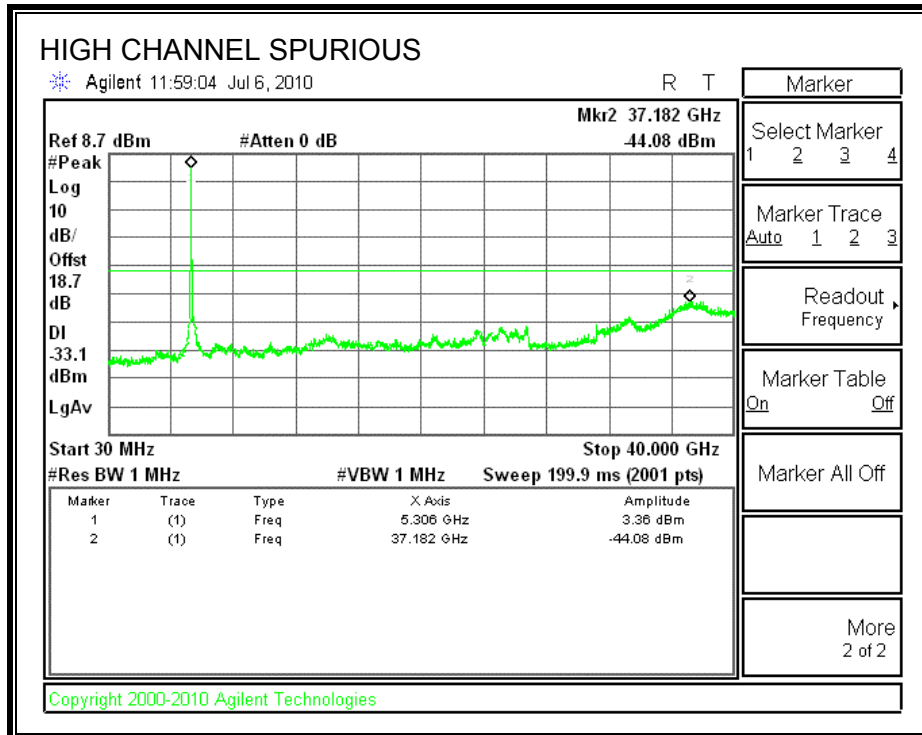
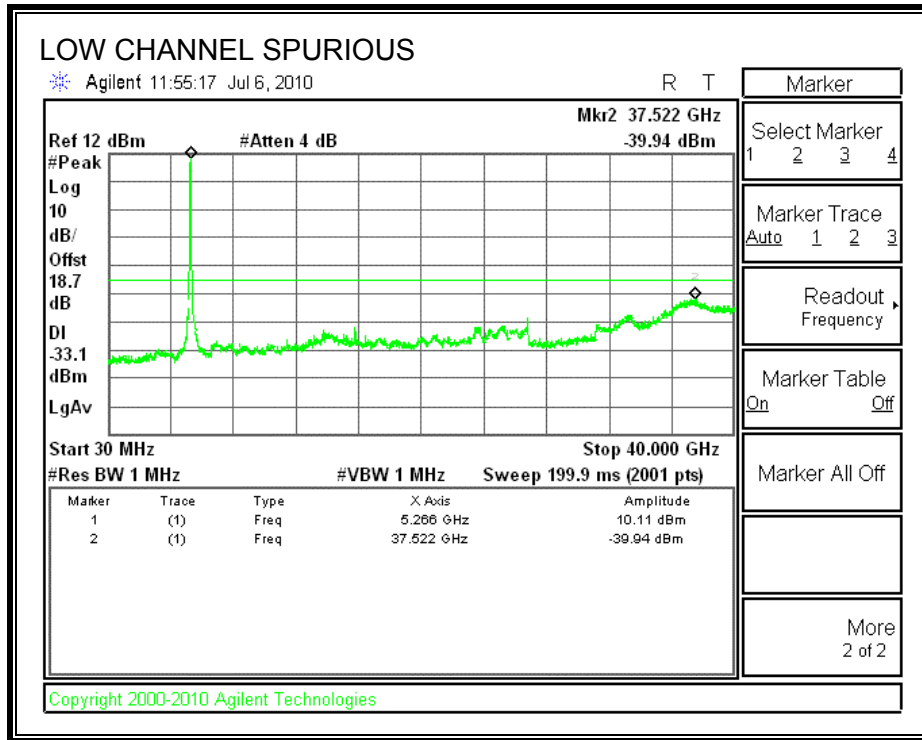

## 7.8. 802.11n HT40 MODE IN THE 5.3 GHz BAND

### 7.8.1. 26 dB and 99% BANDWIDTH

#### LIMITS

None; for reporting purposes only.

#### TEST PROCEDURE

The transmitter outputs are connected to the spectrum analyzer via a combiner. The RBW is set to 1% to 3% of the measured bandwidth. The VBW is set to 3 times the RBW. The sweep time is coupled. The spectrum analyzer internal bandwidth function is utilized.

#### RESULTS

##### CHAIN 0

Channel	Frequency (MHz)	26 dB Bandwidth (MHz)	99% Bandwidth (MHz)
Low	5270	75.794	37.22310
High	5310	38.160	36.14900

##### CHAIN 1

Channel	Frequency (MHz)	26 dB Bandwidth (MHz)	99% Bandwidth (MHz)
Low	5270	71.242	36.7299
High	5310	37.959	36.2002



**CHAIN 0**

**26 dB and 99% BANDWIDTH**

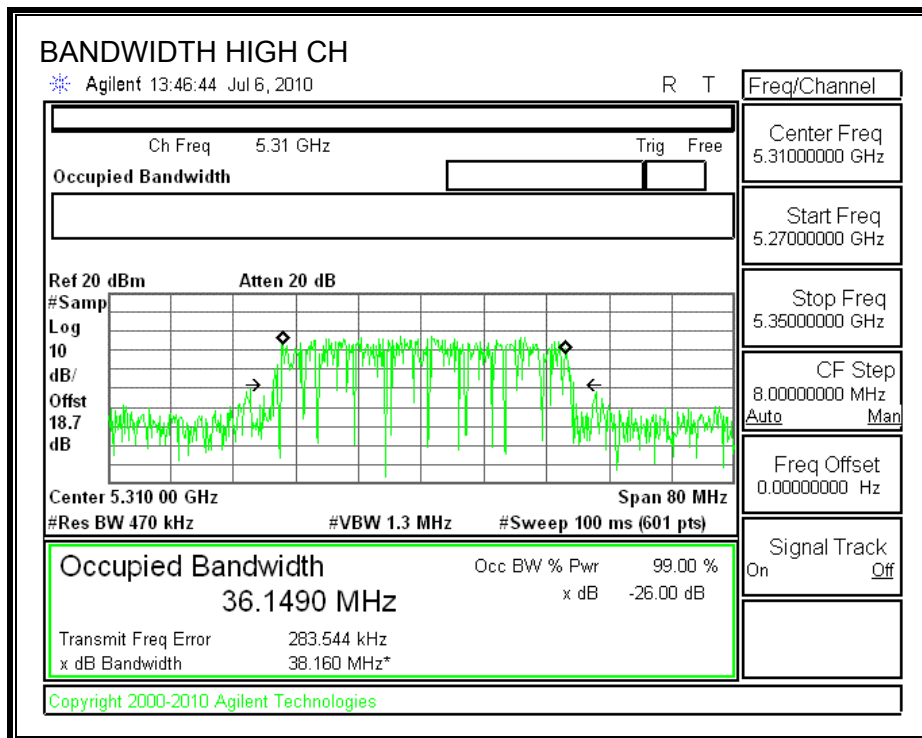
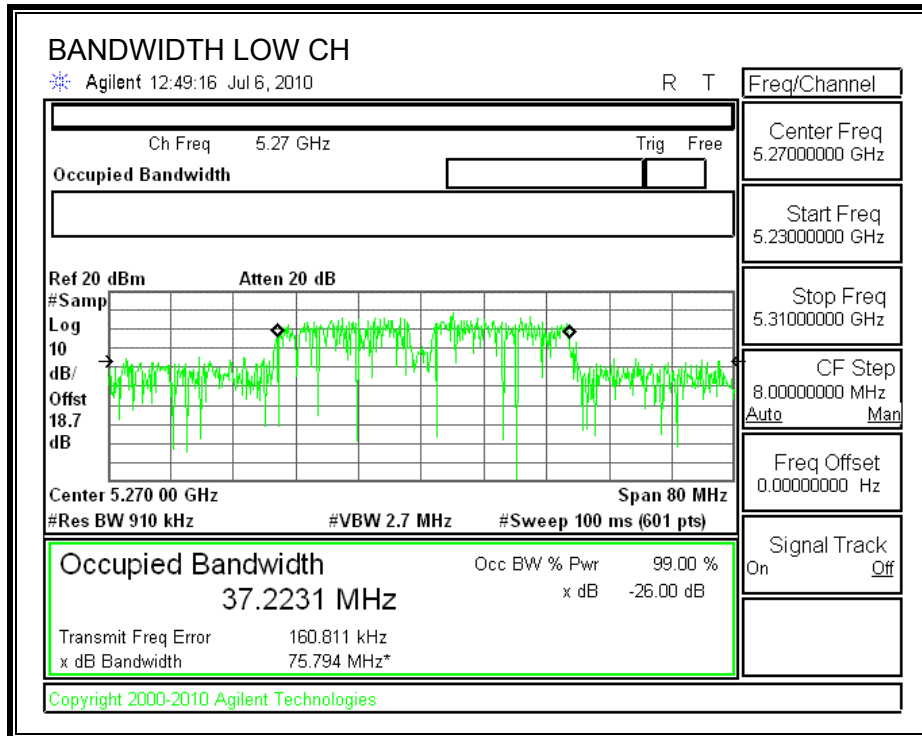

**CHAIN 1**

**26 dB and 99% BANDWIDTH**

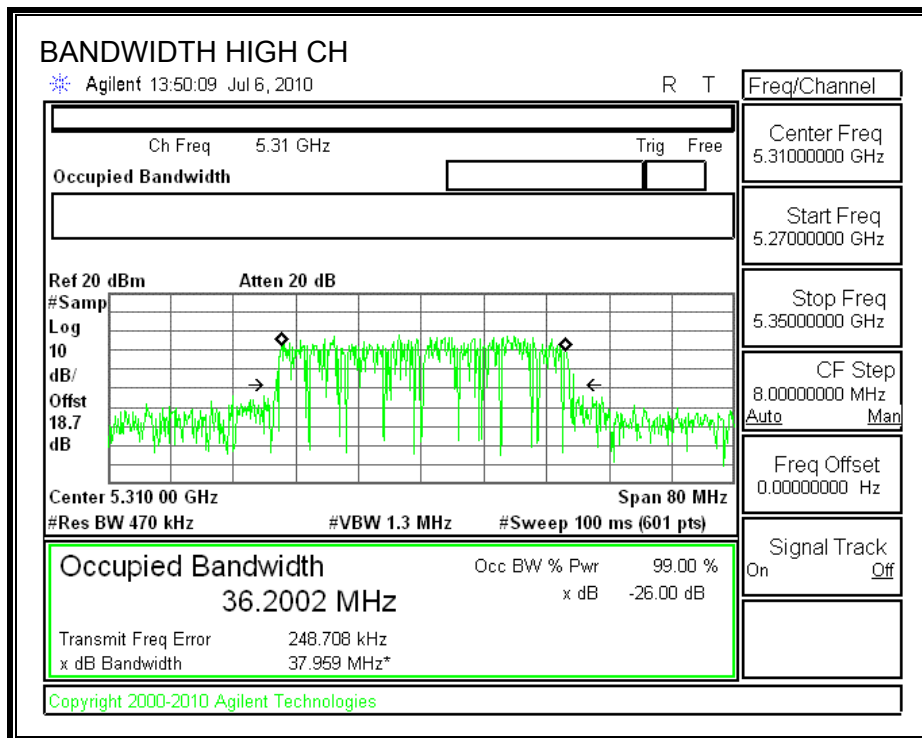
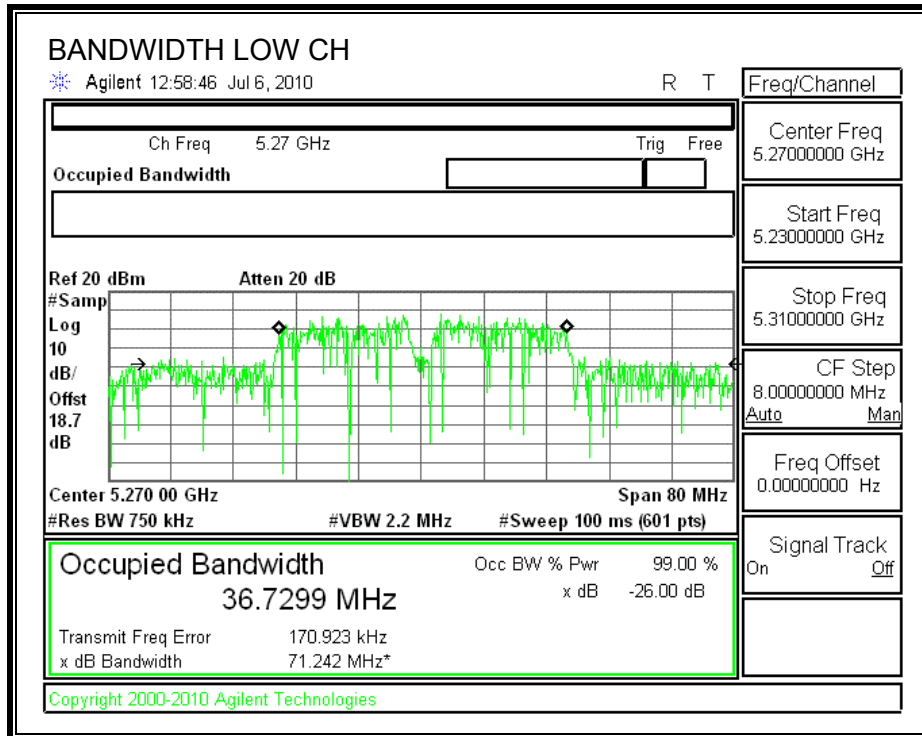

## 7.8.2. OUTPUT POWER

### LIMITS

FCC §15.407 (a) (2)  
 IC RSS-210 A9.2 (2)

For the 5.25-5.35 GHz band, the maximum conducted output power over the frequency band of operation shall not exceed the lesser of 250 mW or  $11 \text{ dBm} + 10 \log B$ , where B is the 26-dB emission bandwidth in MHz. If transmitting antennas of directional gain greater than 6 dBi are used, both the peak transmit power and the peak power spectral density shall be reduced by the amount in dB that the directional gain of the antenna exceeds 6 dBi.

The composite antenna is 8.86dBi.

### TEST PROCEDURE

The test is performed in accordance with FCC Public Notice: APPENDIX A Guidelines for Assessing Unlicensed National Information Infrastructure (U-NII) Devices – Part 15, Subpart E, August 2002.

The transmitter output operates continuously therefore Method # 1 is used.

### RESULTS

#### Limit

Channel	Frequency (MHz)	Fixed Limit (dBm)	B (MHz)	11 + 10 Log B Limit (dBm)	Antenna Gain (dBi)	Limit (dBm)
Low	5270	24	75.794	29.80	8.86	21.14
High	5310	24	38.160	26.82	8.86	21.14

#### Individual Chain Results

Channel	Frequency (MHz)	Chain 0 Power (dBm)	Chain 1 Power (dBm)	Total Power (dBm)	Limit (dBm)	Margin (dB)
Low	5270	15.69	15.76	18.74	21.14	-2.40
High	5310	9.98	9.94	12.97	21.14	-8.17

#### TPC Results

TPC Delta Power		Chain 0	Chain 1			
		5.86	6.62			
Worst-case TPC Power		Chain 0	Chain 1	Total Power	Ant Gain	EIRP
Low	5270	9.83	9.14	12.51	8.86	21.37
TPC Limit (dBm)						24
Margin (dB)						-2.63

**CHAIN 0 OUTPUT POWER**

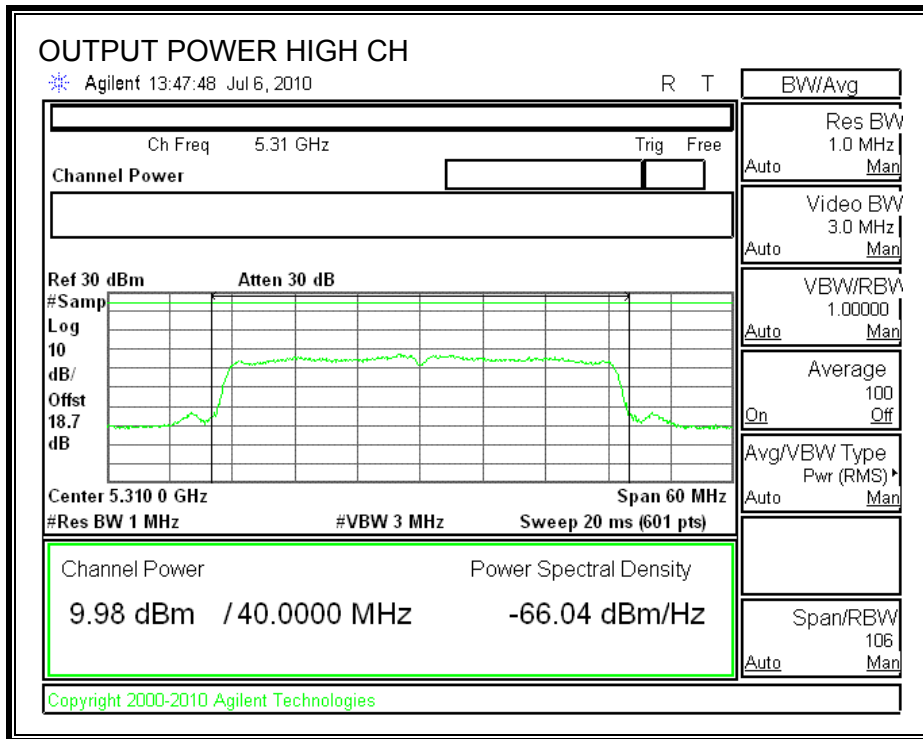
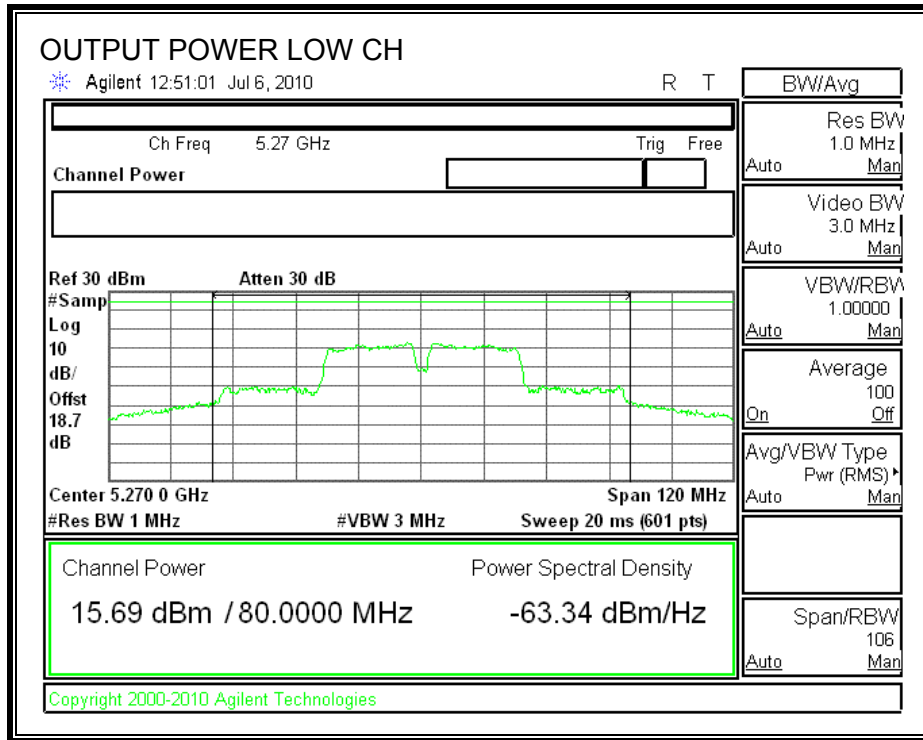

**CHAIN 1 OUTPUT POWER**

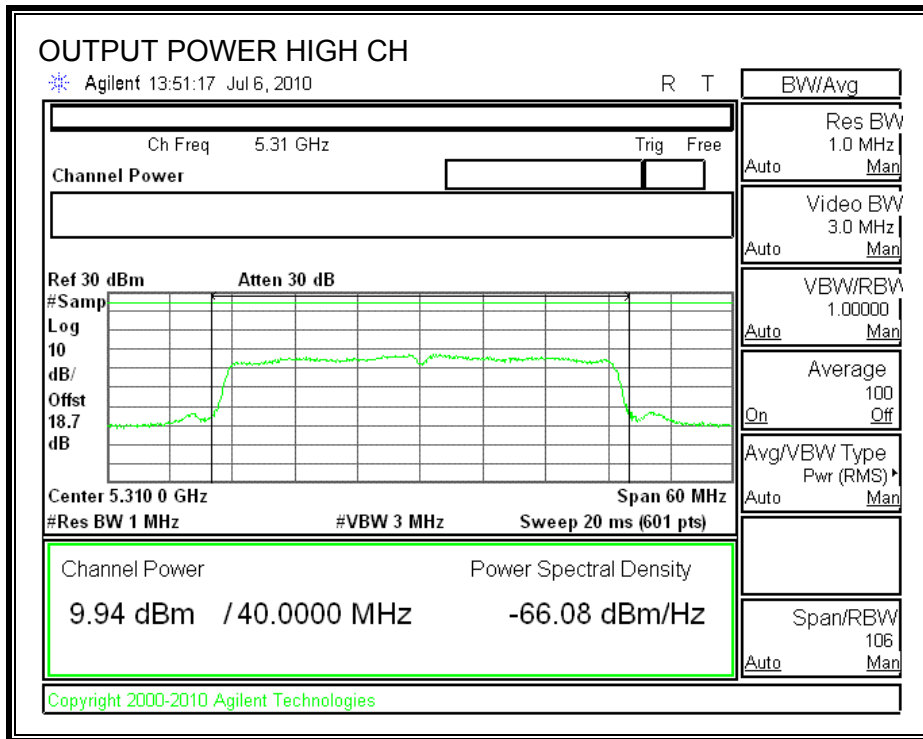
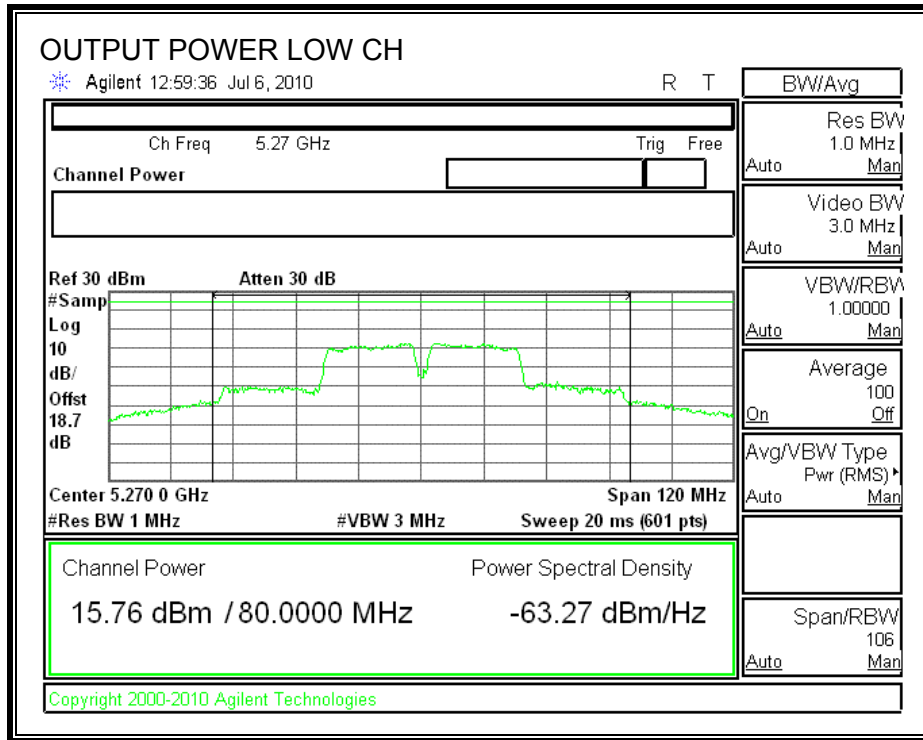

### 7.8.3. PEAK POWER SPECTRAL DENSITY

#### LIMITS

FCC §15.407 (a) (2)

IC RSS-210 A9.2 (2)

For the 5.25-5.35 GHz band, the peak power spectral density shall not exceed 11 dBm in any 1 MHz band. If transmitting antennas of directional gain greater than 6 dBi are used, both the peak transmit power and the peak power spectral density shall be reduced by the amount in dB that the directional gain of the antenna exceeds 6 dBi.

The maximum antenna gain is equal to 8.86 dBi, therefore the limit is 8.14 dBm.

#### TEST PROCEDURE

The test is performed in accordance with FCC Public Notice: APPENDIX A Guidelines for Assessing Unlicensed National Information Infrastructure (U-NII) Devices – Part 15, Subpart E, August 2002. PPSD method #2 was used.

#### RESULTS

Channel	Frequency (MHz)	PPSD With Combiner (dBm)	Limit (dBm)	Margin (dB)
Low	5270	6.54	8.14	-1.60
High	5310	1.32	8.14	-6.82

**POWER SPECTRAL DENSITY WITH COMBINER**

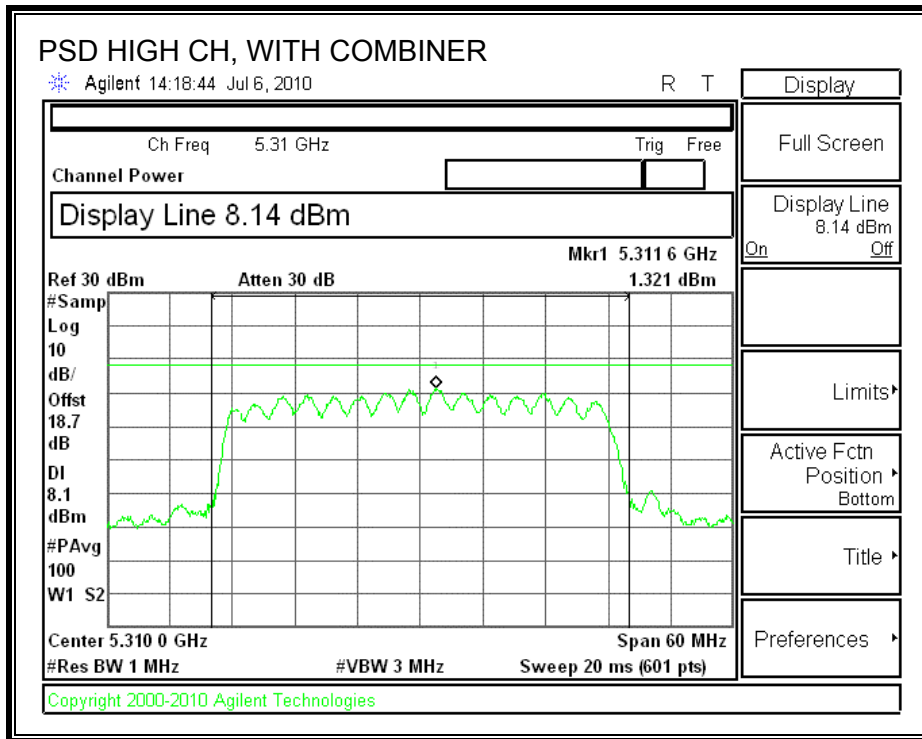
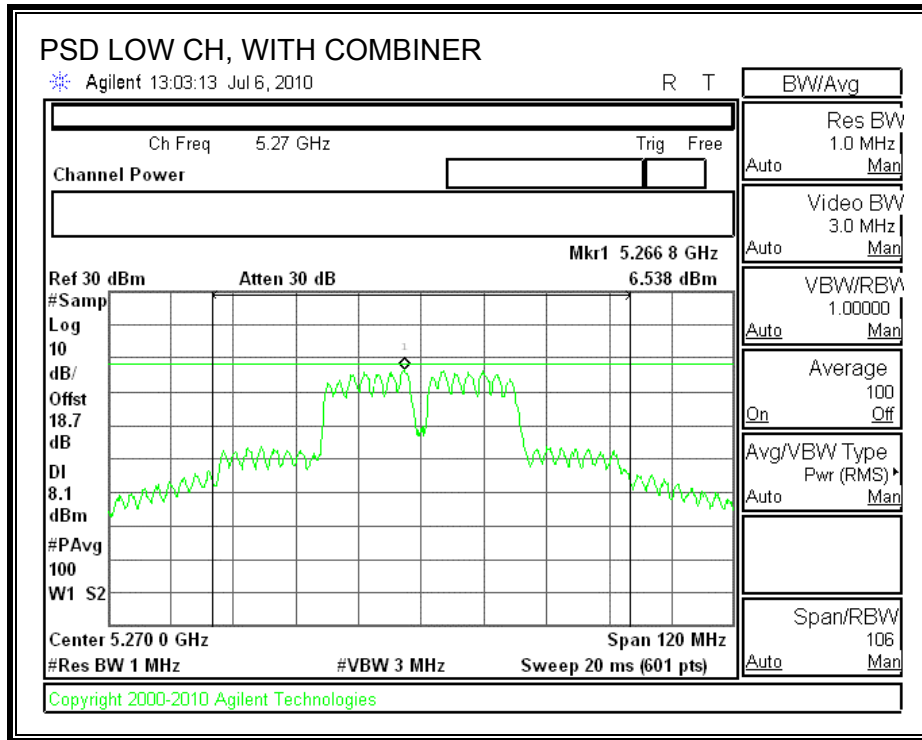

### 7.8.4. PEAK EXCURSION

#### LIMITS

FCC §15.407 (a) (6)

The ratio of the peak excursion of the modulation envelope (measured using a peak hold function) to the peak transmit power (measured as specified above) shall not exceed 13 dB across any 1 MHz bandwidth or the emission bandwidth whichever is less.

#### TEST PROCEDURE

The transmitter outputs are connected to the spectrum analyzer via a combiner.

The test is performed in accordance with FCC Public Notice: APPENDIX A Guidelines for Assessing Unlicensed National Information Infrastructure (U-NII) Devices – Part 15, Subpart E, August 2002.

Since Method # 1 was used for peak power measurements, Method # 1 settings are used for the second PPSD trace.

#### RESULTS

##### CHAIN 1

Channel	Frequency (MHz)	Peak Excursion (dB)	Limit (dB)	Margin (dB)
Low	5270	8.37	13	-4.63
High	5310	10.13	13	-2.87

##### CHAIN 2

Channel	Frequency (MHz)	Peak Excursion (dB)	Limit (dB)	Margin (dB)
Low	5270	9.52	13	-3.48
High	5310	9.95	13	-3.05



**CHAIN 0**

**PEAK EXCURSION**

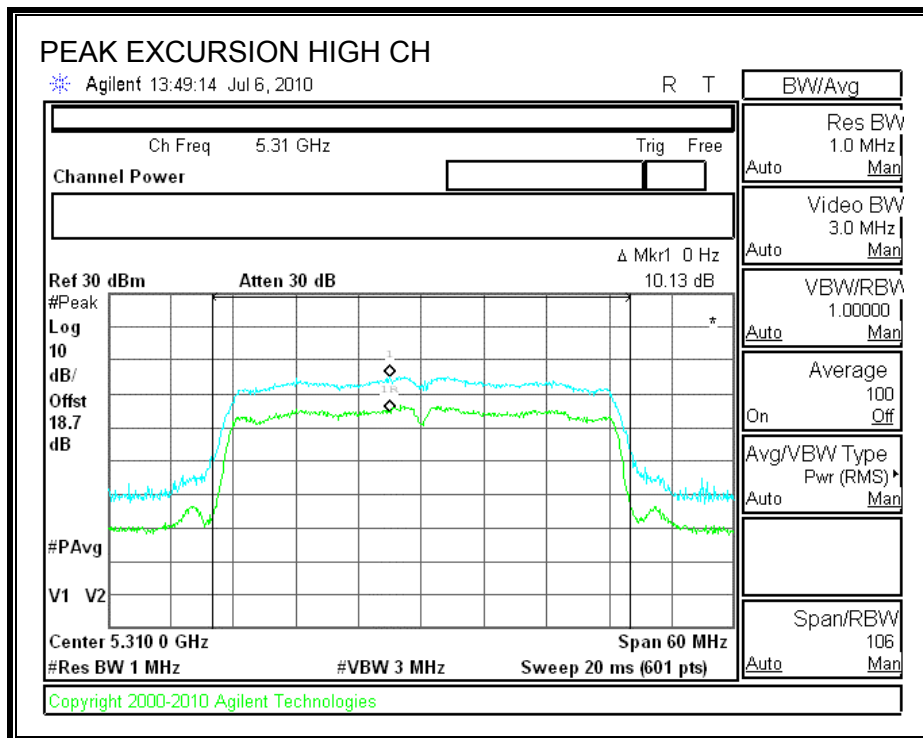
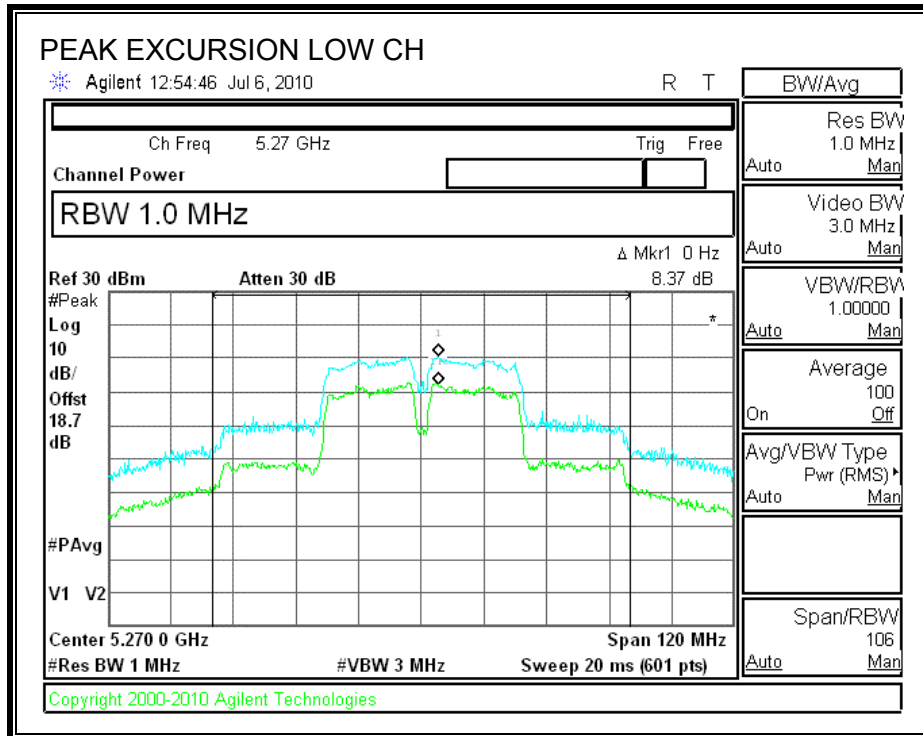

**CHAIN 1**

**PEAK EXCURSION**

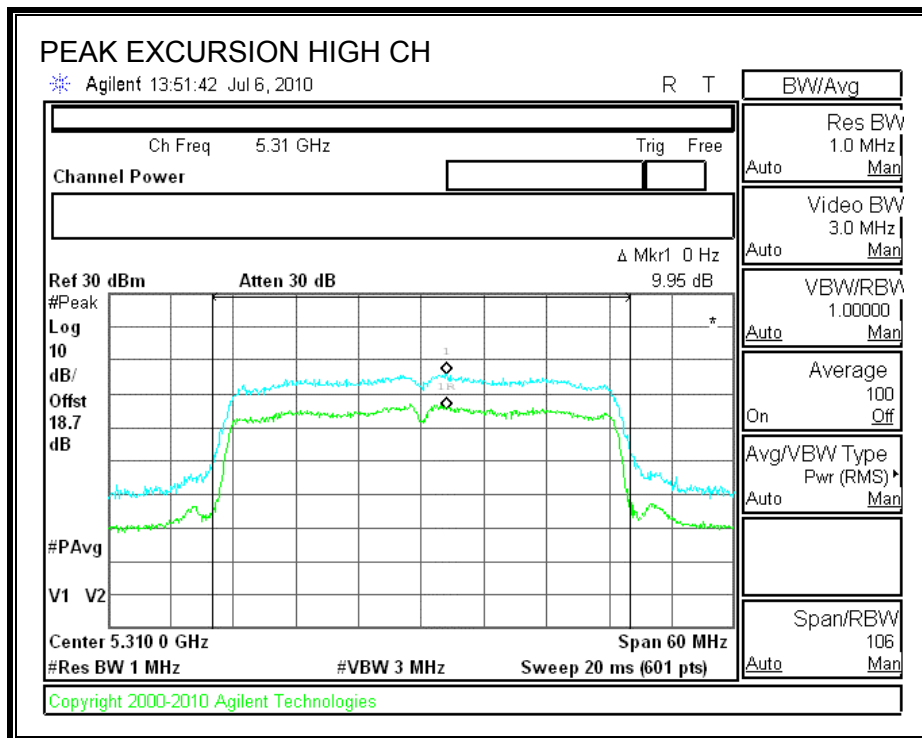
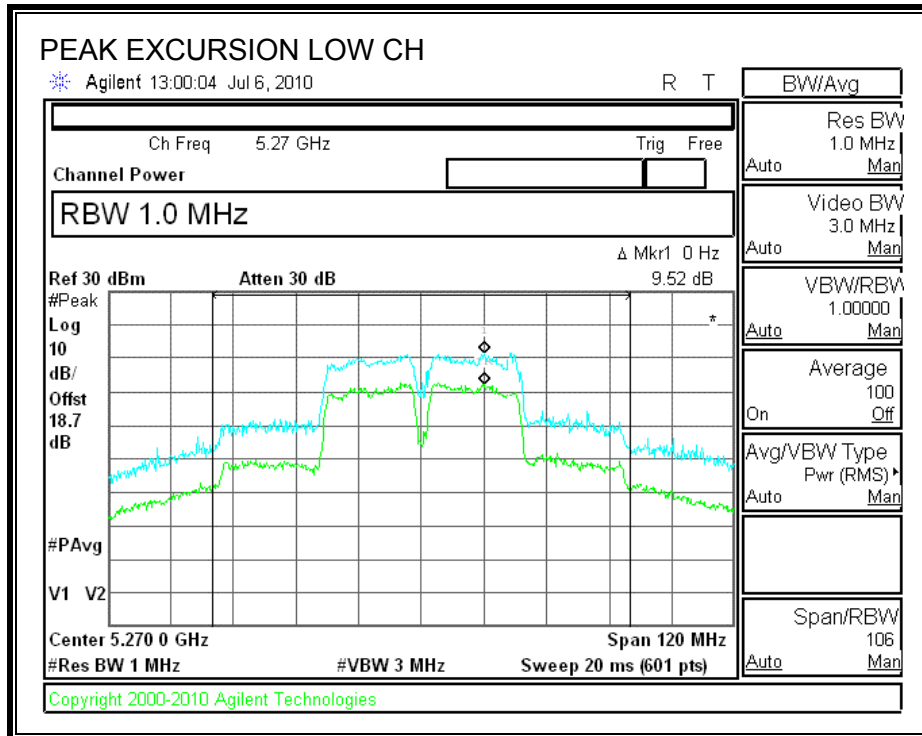

## 7.8.5. CONDUCTED SPURIOUS EMISSIONS

### LIMITS

FCC §15.407 (b) (2)

IC RSS-210 A9.3 (2)

For transmitters operating in the 5.25-5.35 GHz band: all emissions outside of the 5.25-5.35 GHz band shall not exceed an EIRP of -27 dBm / MHz.

Devices operating in the 5.25-5.35 GHz band that generate emissions in the 5.15-5.25 GHz band must meet all applicable technical requirements for operation in the 5.15-5.25 GHz band (including indoor use) or alternatively meet an out-of-band emission EIRP limit of -27 dBm/MHz in the 5.15-5.25 GHz band.

### TEST PROCEDURE

Conducted RF measurements of the transmitter output are made to confirm that the EUT antenna port conducted emissions meet the specified limit and to identify any spurious signals that require further investigation or measurements on the radiated emissions site.

The transmitter output is connected to the spectrum analyzer. The resolution bandwidth is set to 1 MHz. The video bandwidth is set to 1MHz. Peak detection measurements are compared to EIRP limit, adjusted for the maximum antenna gain.

Measurements are made over the 30 MHz to 40 GHz range with the transmitter set to the lowest, middle, and highest channels.

**SPURIOUS EMISSIONS WITH COMBINER**

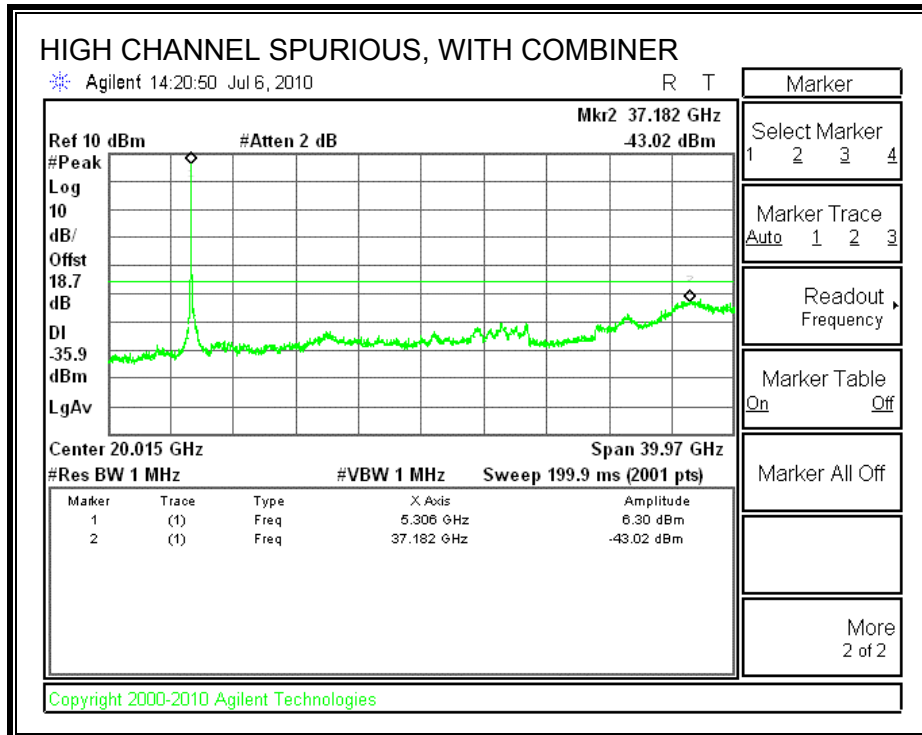
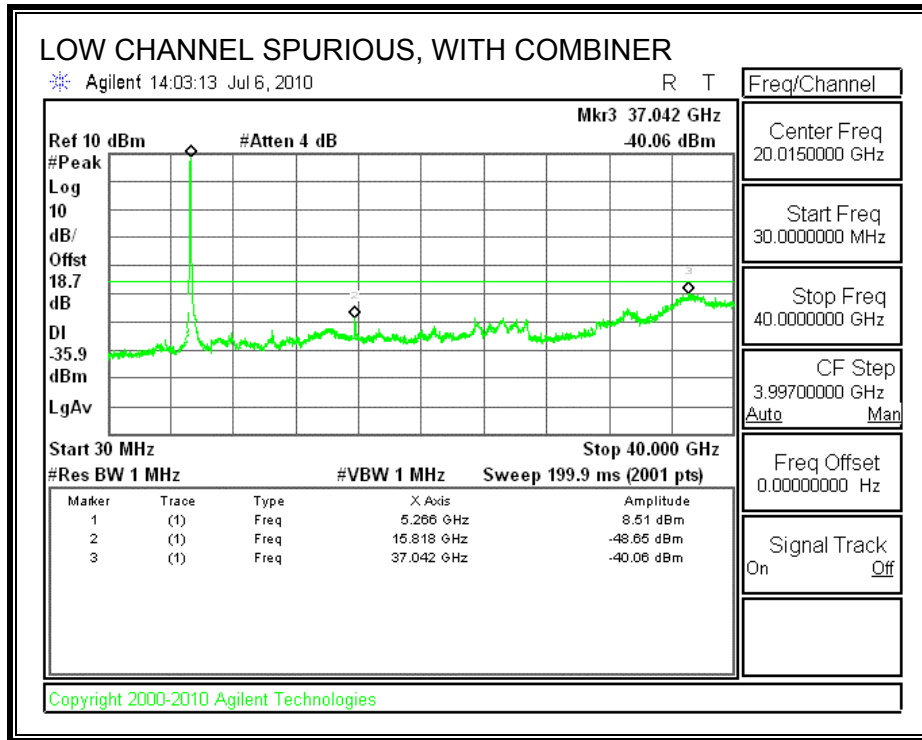

## 7.9. 802.11a MODE IN THE 5.6 GHz BAND

### 7.9.1. 26 dB and 99% BANDWIDTH

#### LIMITS

None; for reporting purposes only.

#### TEST PROCEDURE

The transmitter output is connected to the spectrum analyzer. The RBW is set to 1% to 3% of the measured bandwidth. The VBW is set to 3 times the RBW. The sweep time is coupled. The spectrum analyzer internal bandwidth function is utilized.

#### RESULTS

Channel	Frequency (MHz)	26 dB Bandwidth (MHz)	99% Bandwidth (MHz)
Low	5500	18.588	16.3459
Middle	5600	23.020	16.5433
High	5700	18.845	16.4164

**26 dB and 99% BANDWIDTH**

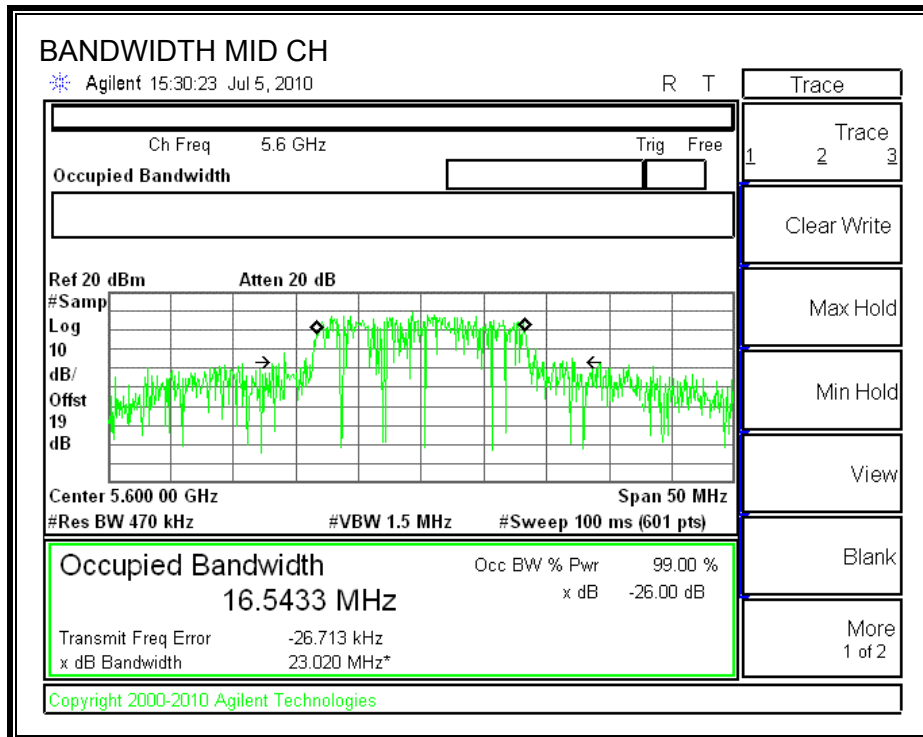
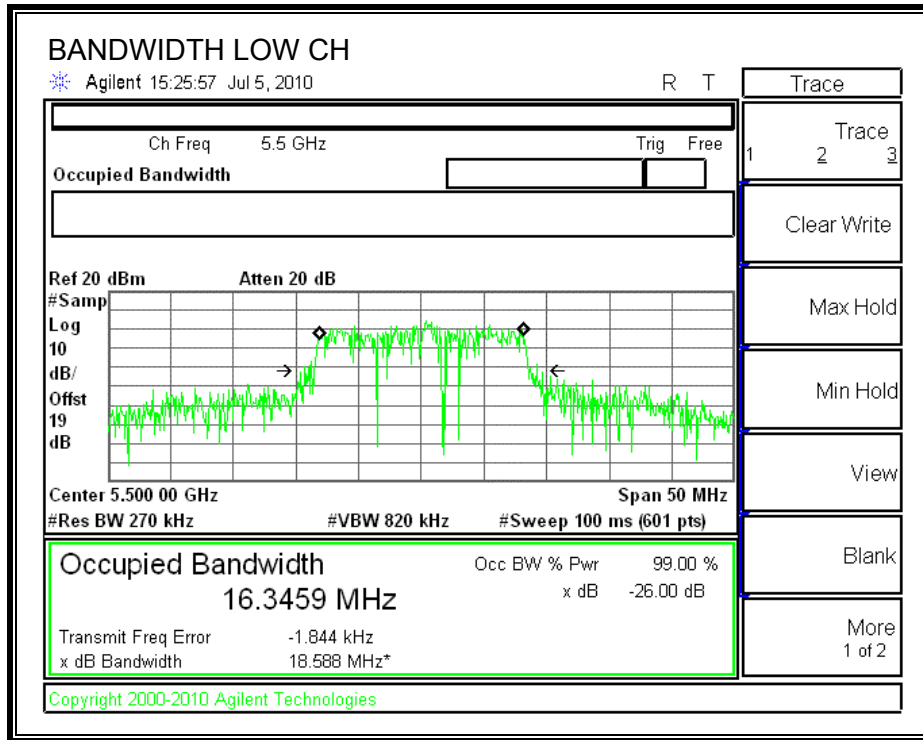

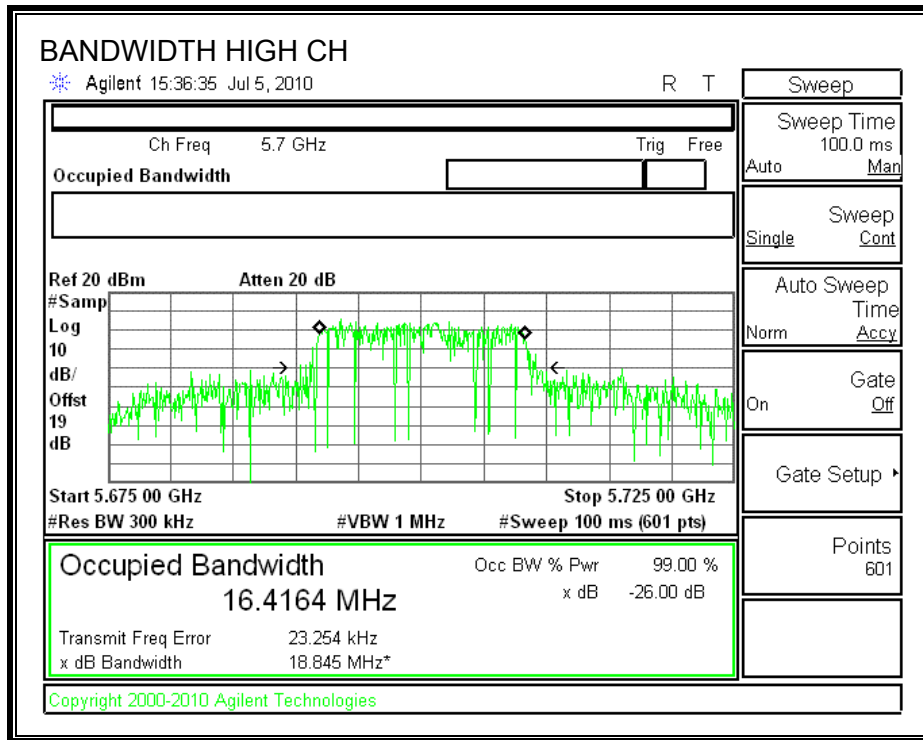

## 7.9.2. OUTPUT POWER

### LIMITS

FCC §15.407 (a) (2)

IC RSS-210 A9.2 (2)

For the 5.47-5.725 GHz band, the maximum conducted output power over the frequency band of operation shall not exceed the lesser of 250 mW or  $11 \text{ dBm} + 10 \log B$ , where B is the 26-dB emission bandwidth in MHz. If transmitting antennas of directional gain greater than 6 dBi are used, both the peak transmit power and the peak power spectral density shall be reduced by the amount in dB that the directional gain of the antenna exceeds 6 dBi.

The maximum antenna gain is 6.61dBi

### TEST PROCEDURE

The test is performed in accordance with FCC Public Notice: APPENDIX A Guidelines for Assessing Unlicensed National Information Infrastructure (U-NII) Devices – Part 15, Subpart E, August 2002.

The transmitter output operates continuously therefore Method # 1 is used.

### RESULTS

#### Limit

Channel	Frequency (MHz)	Fixed Limit (dBm)	B (MHz)	11 + 10 Log B Limit (dBm)	Antenna Gain (dBi)	Limit (dBm)
Low	5500	24	18.588	23.69	6.61	23.08
Mid	5600	24	23.020	24.62	6.61	23.39
High	5700	24	18.845	23.75	6.61	23.14

#### Results

Channel	Frequency (MHz)	Power (dBm)	Limit (dBm)	Margin (dB)
Low	5500	14.83	23.08	-8.25
Mid	5600	17.37	23.39	-6.02
High	5700	15.39	23.14	-7.75



**OUTPUT POWER**

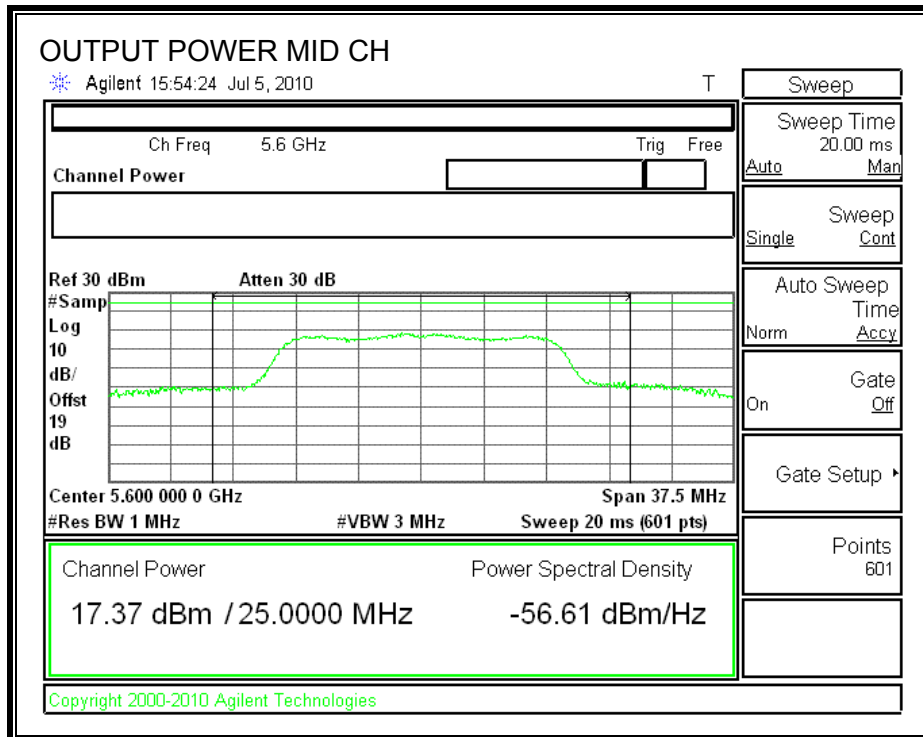
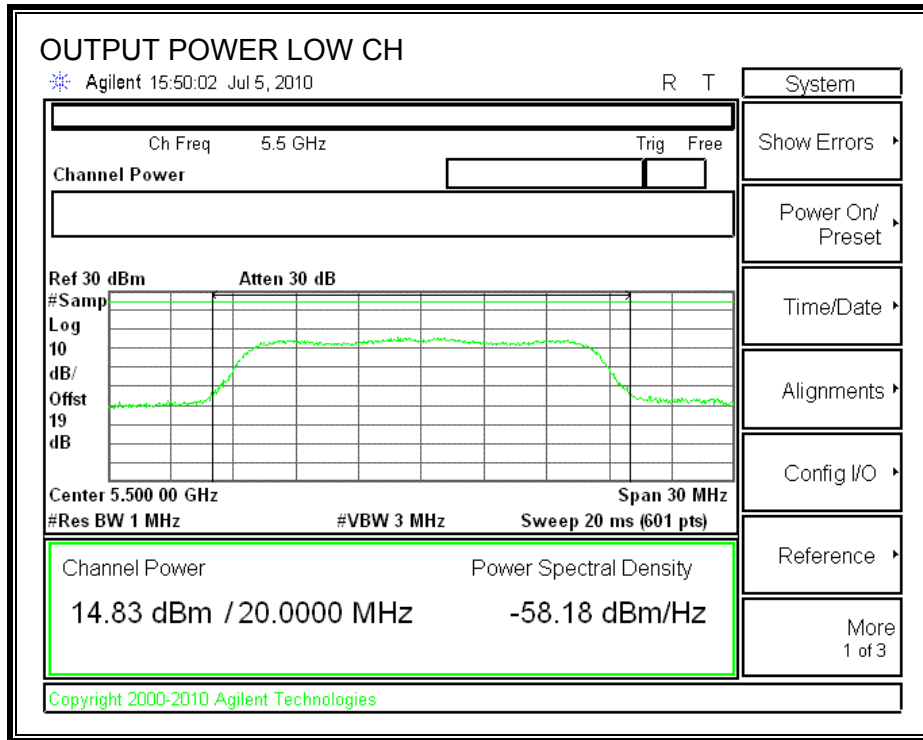

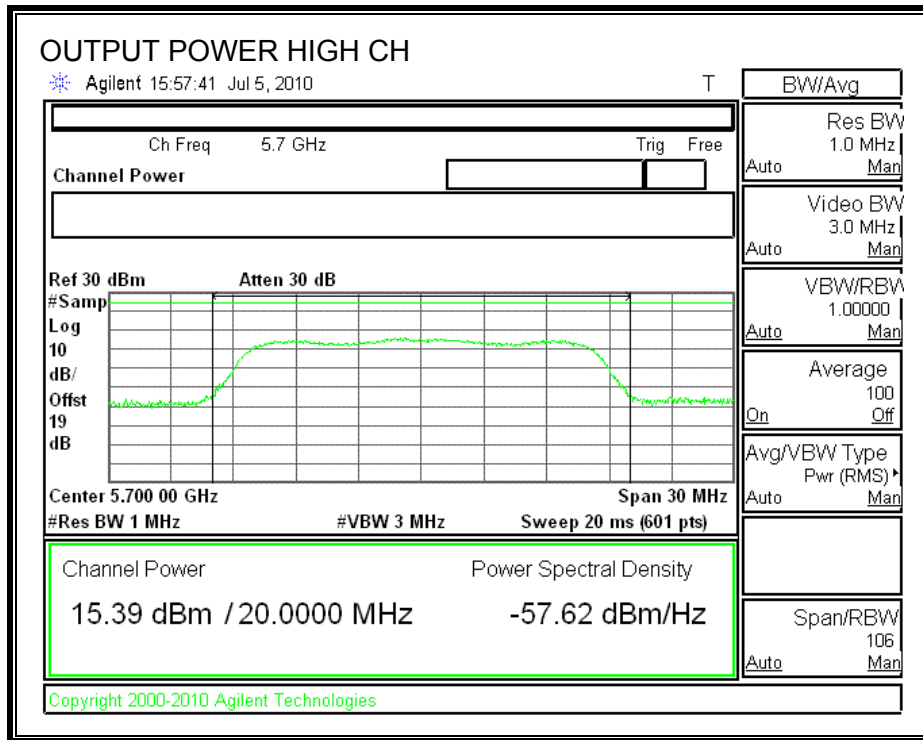

### 7.9.3. PEAK POWER SPECTRAL DENSITY

#### LIMITS

FCC §15.407 (a) (2)

IC RSS-210 A9.2 (2)

For the 5.47-5.725 GHz band, the peak power spectral density shall not exceed 11 dBm in any 1 MHz band. If transmitting antennas of directional gain greater than 6 dBi are used, both the peak transmit power and the peak power spectral density shall be reduced by the amount in dB that the directional gain of the antenna exceeds 6 dBi.

The maximum antenna gain is equal to 6.61 dBi, therefore the limit is 10.39 dBm.

#### TEST PROCEDURE

The test is performed in accordance with FCC Public Notice: APPENDIX A Guidelines for Assessing Unlicensed National Information Infrastructure (U-NII) Devices – Part 15, Subpart E, August 2002. PPSD method #2 was used.

#### RESULTS

Channel	Frequency (MHz)	PPSD (dBm)	Limit (dBm)	Margin (dB)
Low	5500	5.25	10.39	-5.14
Middle	5600	7.98	10.39	-2.41
High	5700	5.33	10.39	-5.06

**POWER SPECTRAL DENSITY**

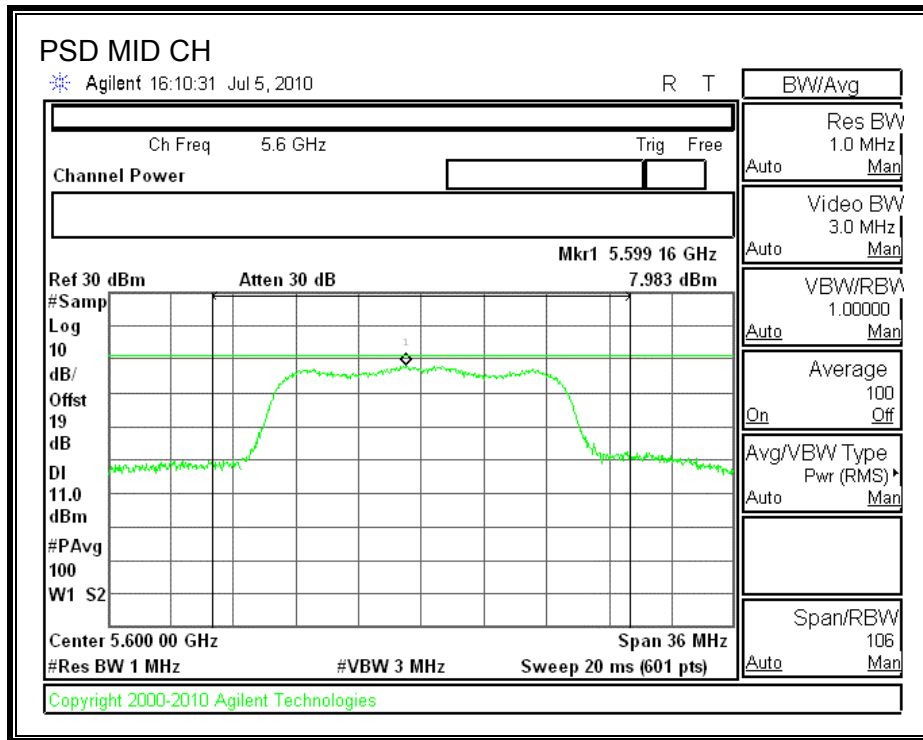
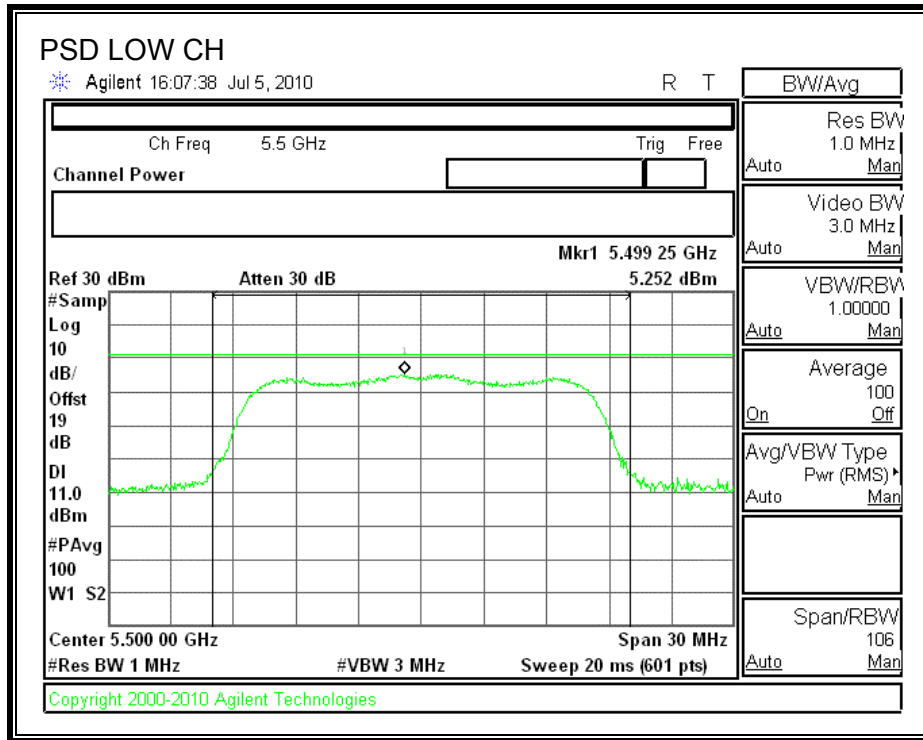

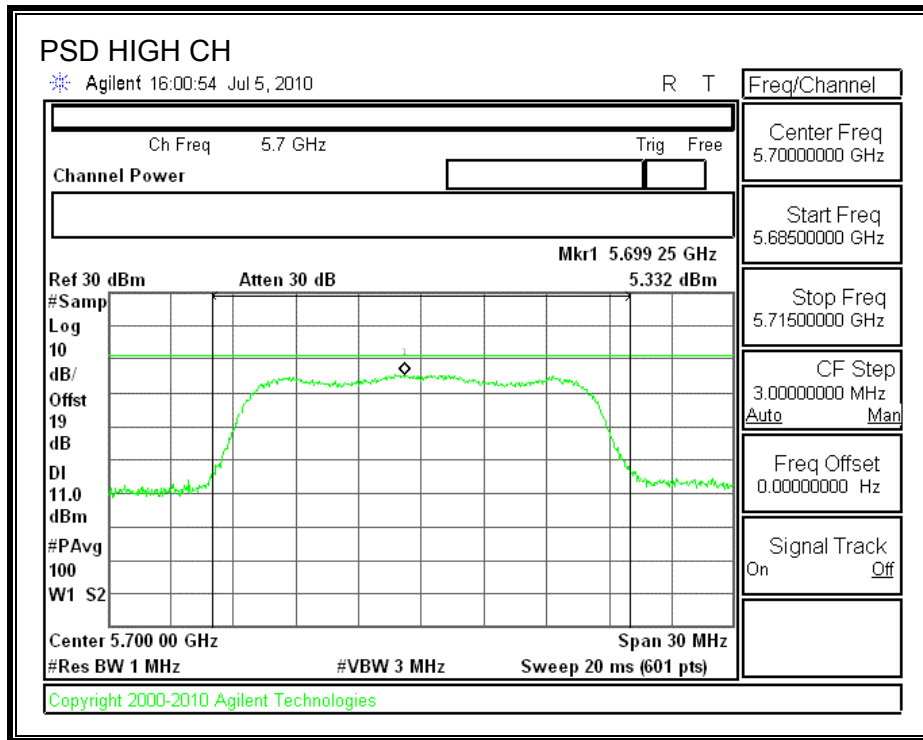

### 7.9.4. PEAK EXCURSION

#### LIMITS

FCC §15.407 (a) (6)

The ratio of the peak excursion of the modulation envelope (measured using a peak hold function) to the peak transmit power (measured as specified above) shall not exceed 13 dB across any 1 MHz bandwidth or the emission bandwidth whichever is less.

#### TEST PROCEDURE

The test is performed in accordance with FCC Public Notice: APPENDIX A Guidelines for Assessing Unlicensed National Information Infrastructure (U-NII) Devices – Part 15, Subpart E, August 2002.

Since Method # 1 was used for peak power measurements, Method # 1 settings are used for the second PPSD trace.

#### RESULTS

Channel	Frequency (MHz)	Peak Excursion (dB)	Limit (dB)	Margin (dB)
Low	5500	9.84	13	-3.16
Middle	5600	10.96	13	-2.04
High	5700	9.77	13	-3.23

**PEAK EXCURSION**

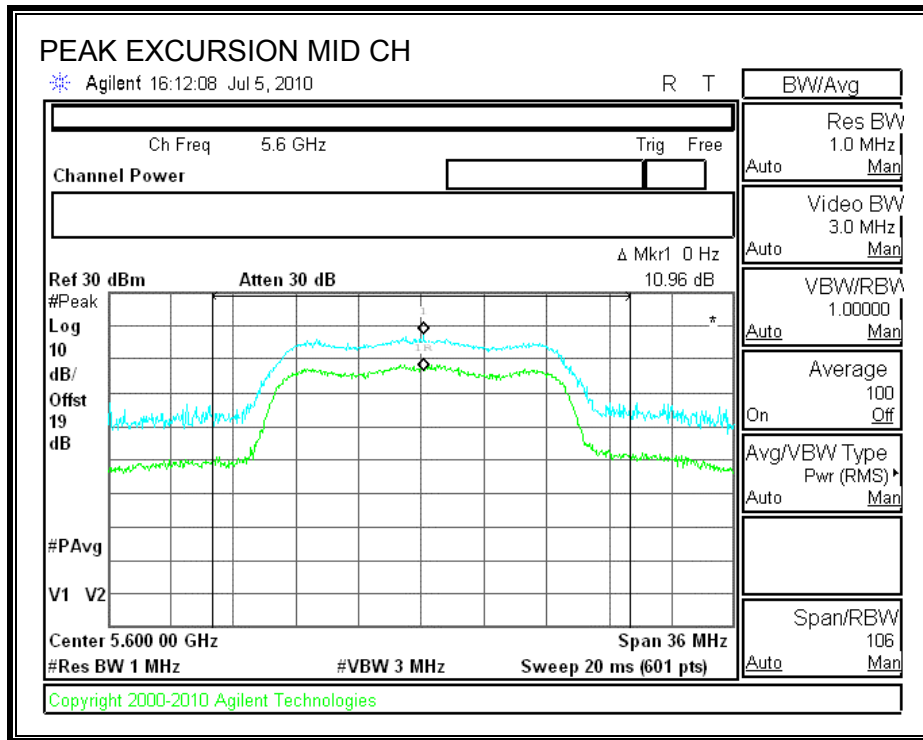
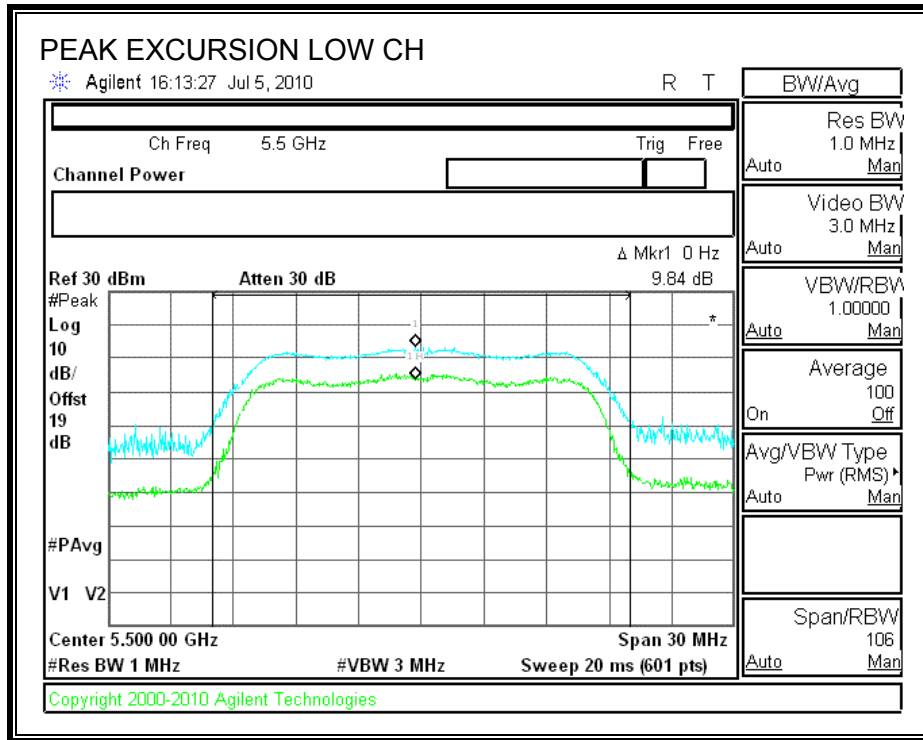

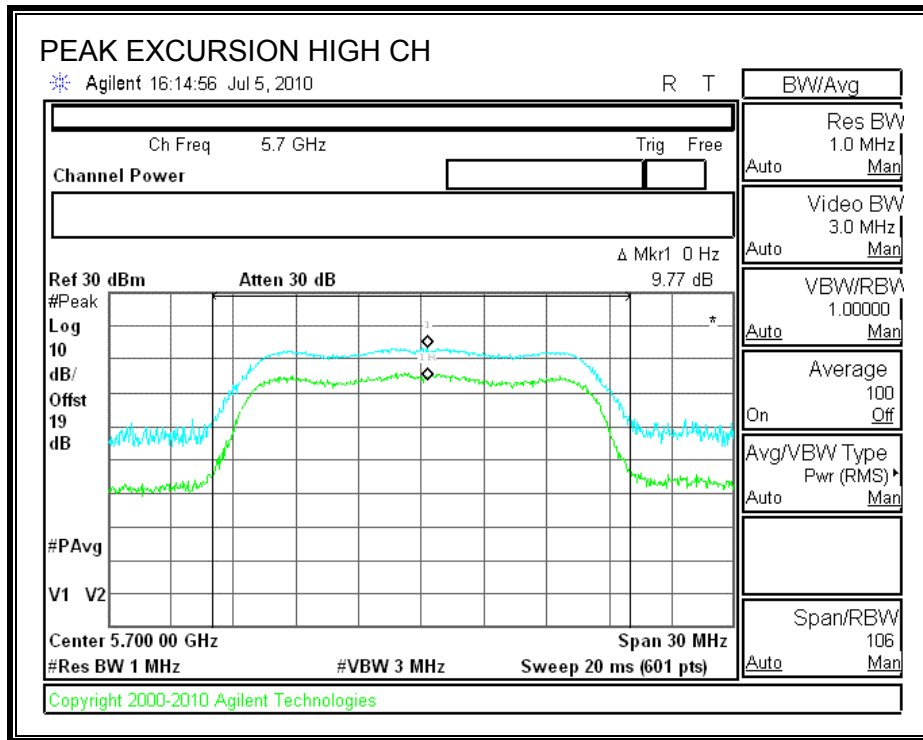



## 7.9.5. CONDUCTED SPURIOUS EMISSIONS

### LIMITS

FCC §15.407 (b) (3)

IC RSS-210 A9.3 (3)

For transmitters operating in the 5.47-5.725 GHz band: all emissions outside of the 5.47-5.725 GHz band shall not exceed an EIRP of -27 dBm / MHz.

### TEST PROCEDURE

Conducted RF measurements of the transmitter output are made to confirm that the EUT antenna port conducted emissions meet the specified limit and to identify any spurious signals that require further investigation or measurements on the radiated emissions site.

The transmitter output is connected to the spectrum analyzer. The resolution bandwidth is set to 1 MHz. The video bandwidth is set to 1MHz. Peak detection measurements are compared to EIRP limit, adjusted for the maximum antenna gain.

Measurements are made over the 30 MHz to 40 GHz range with the transmitter set to the lowest, middle, and highest channels.

**SPURIOUS EMISSIONS**

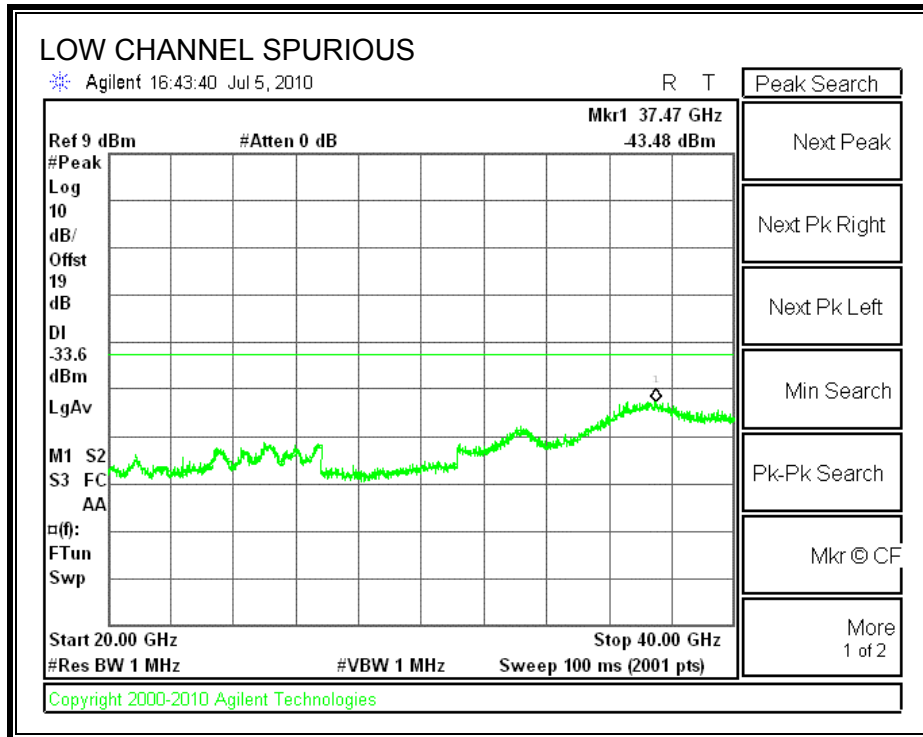
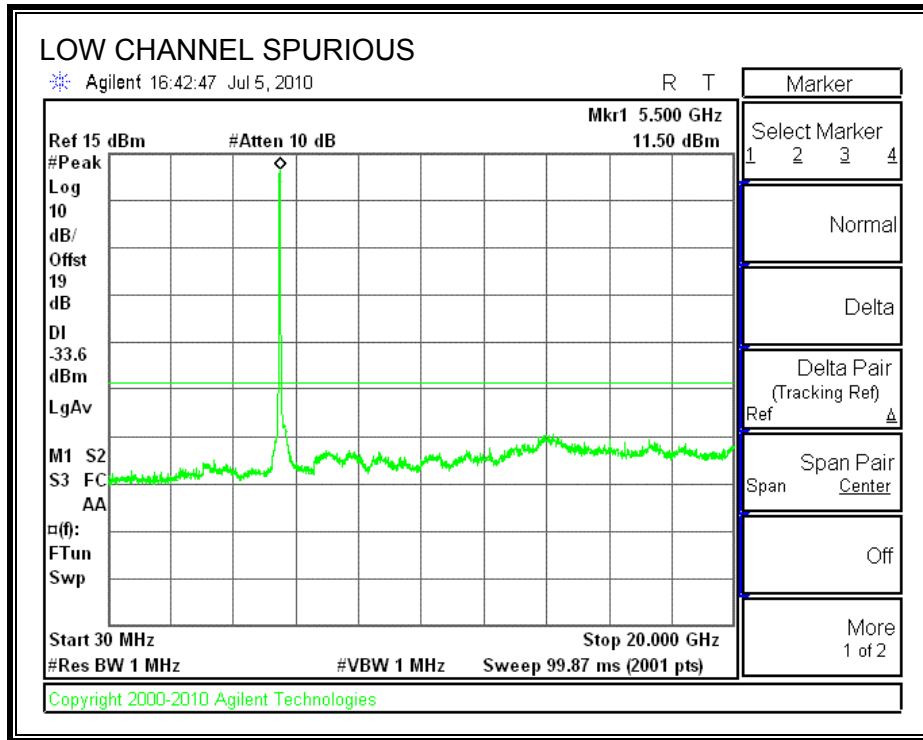



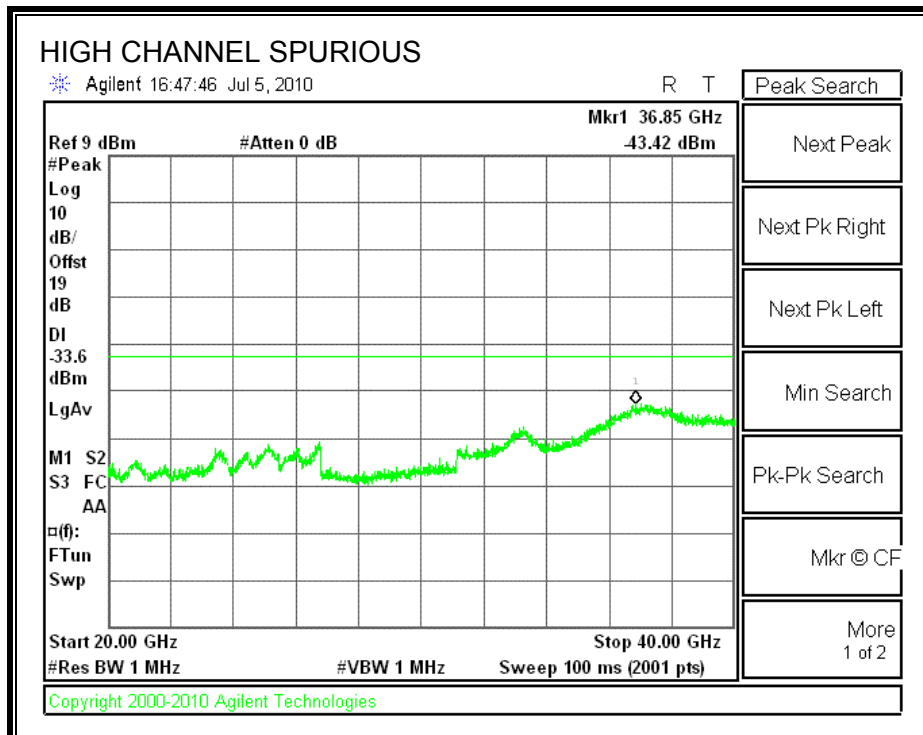
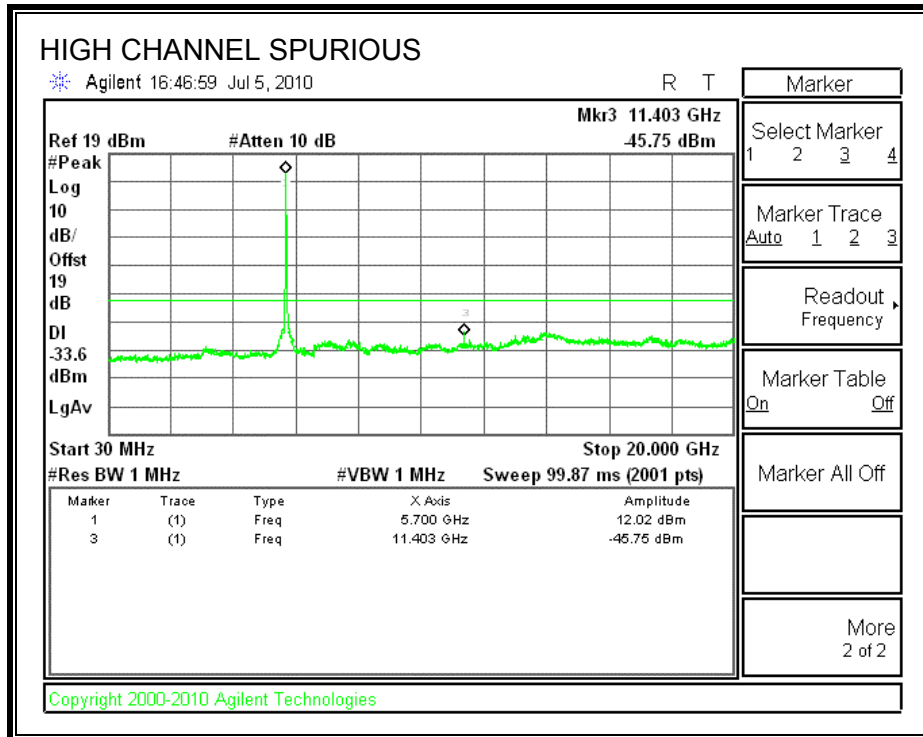

## 7.10. 802.11n HT20 MODE IN THE 5.6 GHz BAND

### 7.10.1. 26 dB and 99% BANDWIDTH

#### LIMITS

None; for reporting purposes only.

#### TEST PROCEDURE

The transmitter outputs are connected to the spectrum analyzer via a combiner. The RBW is set to 1% to 3% of the measured bandwidth. The VBW is set to 3 times the RBW. The sweep time is coupled. The spectrum analyzer internal bandwidth function is utilized.

#### RESULTS

##### CHAIN 0

Channel	Frequency (MHz)	26 dB Bandwidth (MHz)	99% Bandwidth (MHz)
Low	5500	18.625	17.518
Middle	5600	18.629	17.443
High	5700	18.923	17.5135

##### CHAIN 1

Channel	Frequency (MHz)	26 dB Bandwidth (MHz)	99% Bandwidth (MHz)
Low	5500	19.083	17.5471
Middle	5600	18.660	17.381
High	5700	18.389	17.5023

**CHAIN 0**

**26 dB and 99% BANDWIDTH**

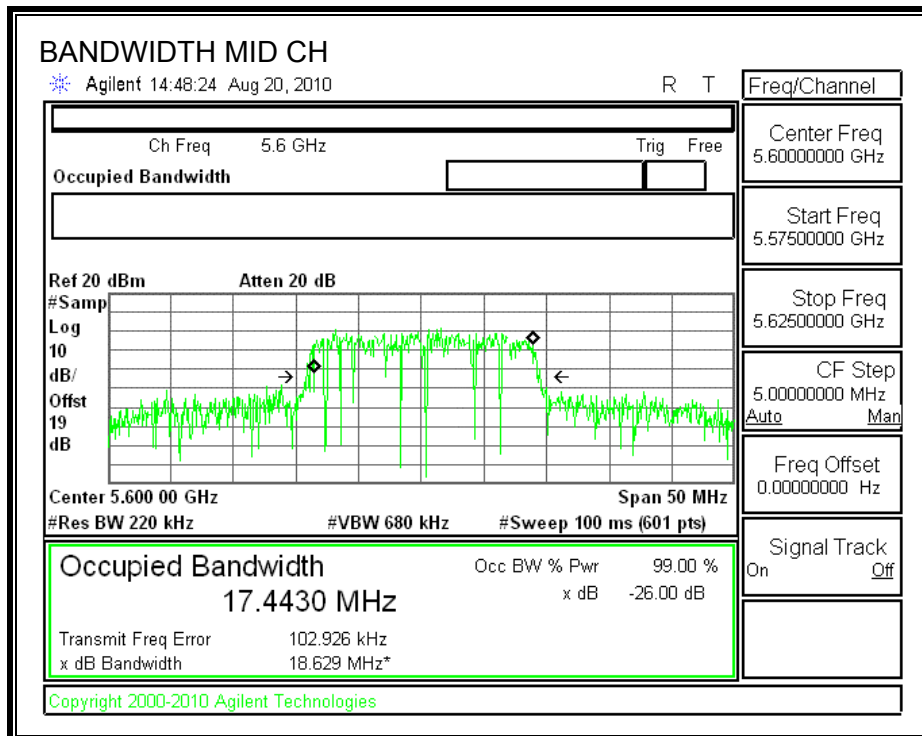
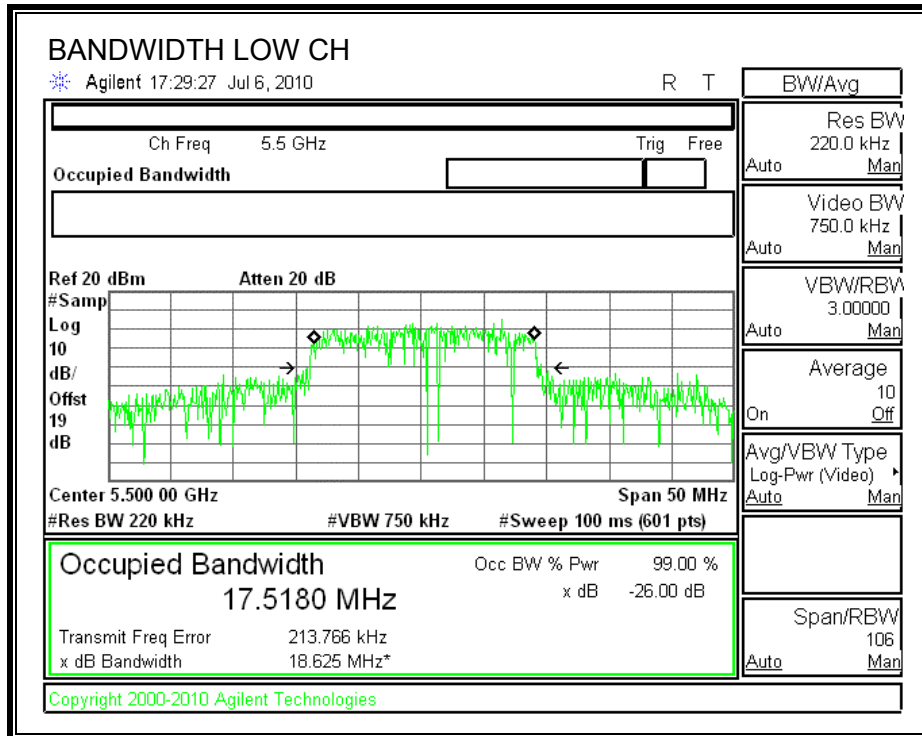

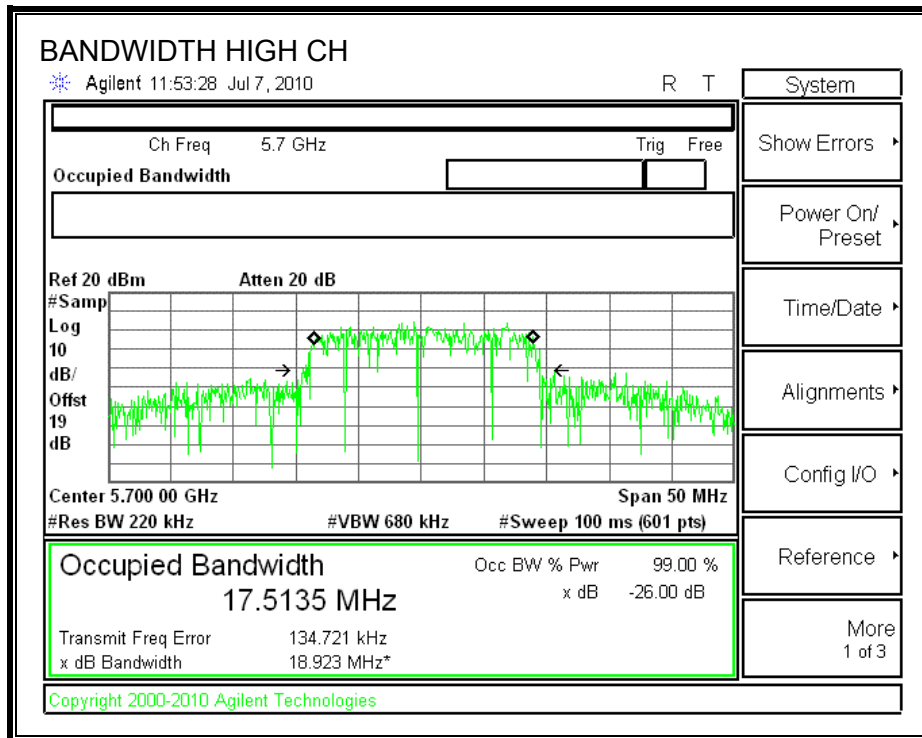

**CHAIN 1**

**26 dB and 99% BANDWIDTH**

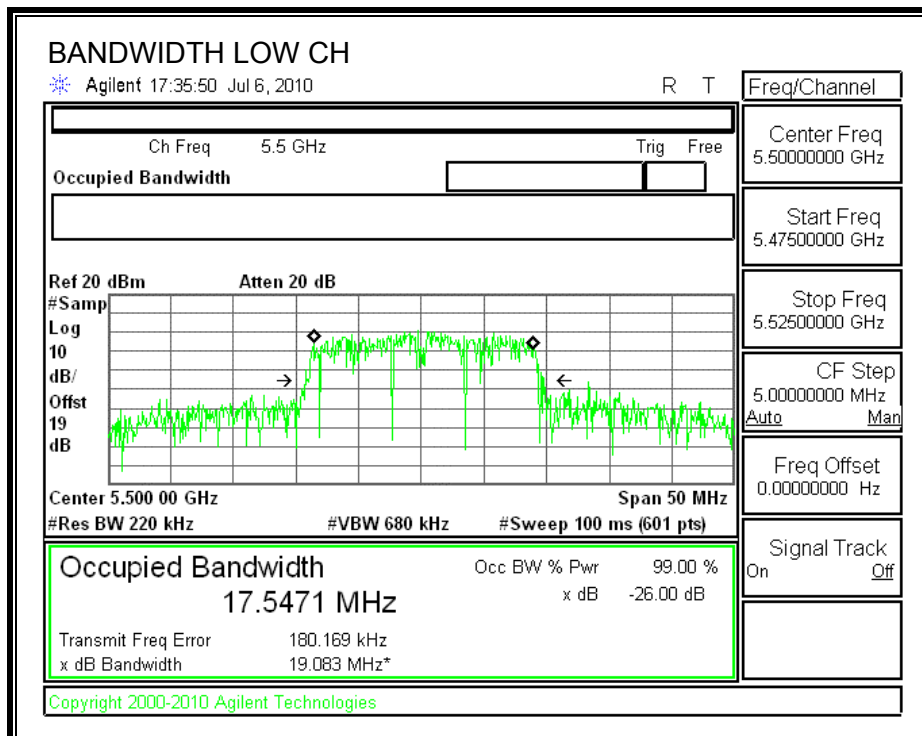

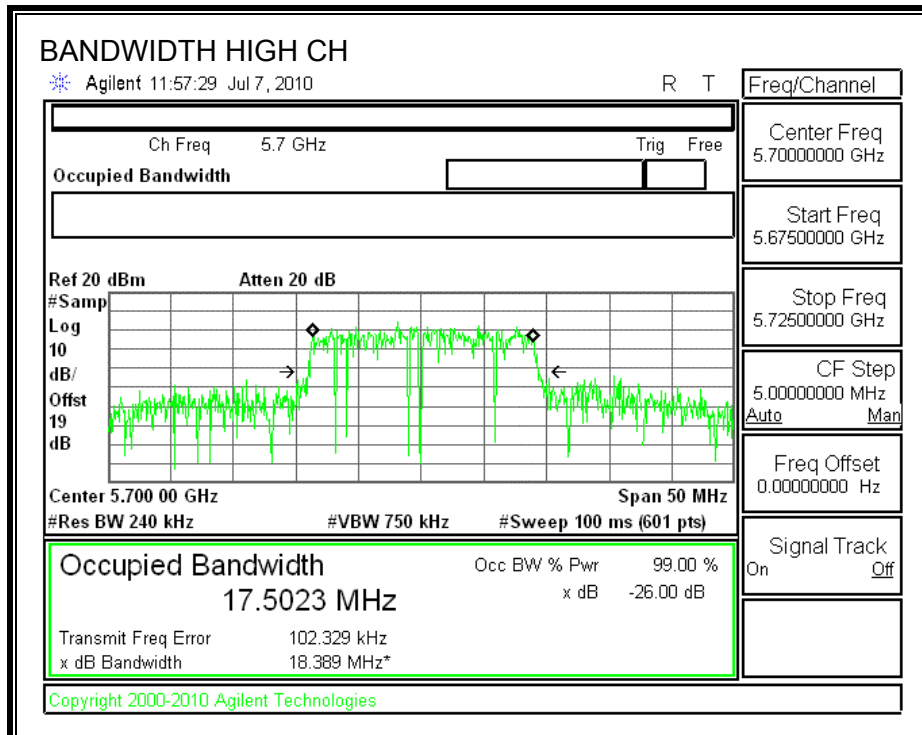
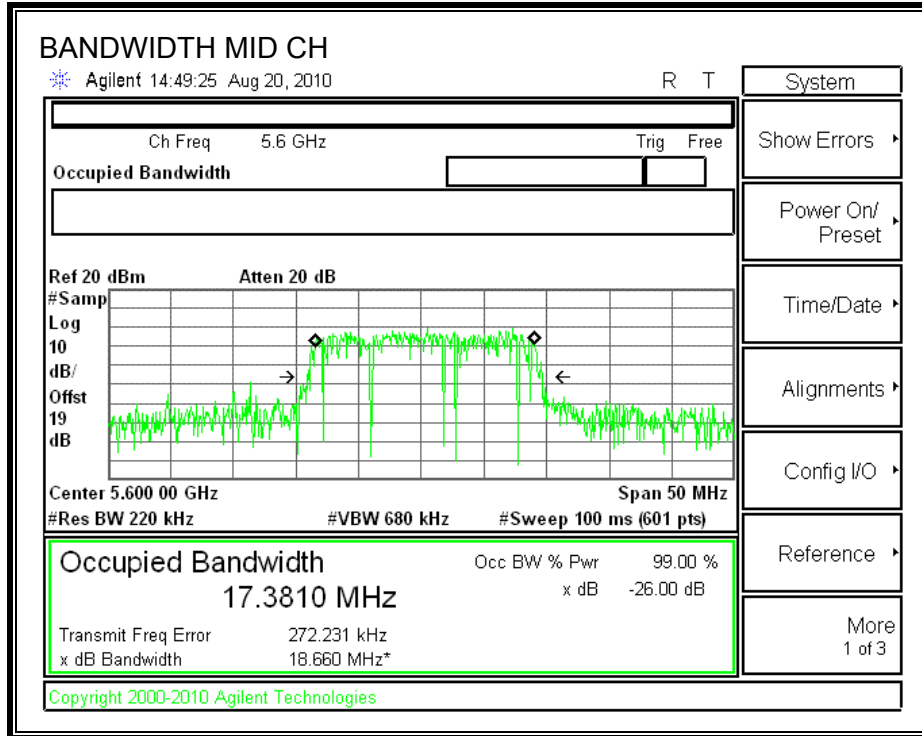



**7.10.2. OUTPUT POWER**

**LIMITS**

FCC §15.407 (a) (2)

IC RSS-210 A9.2 (2)

For the 5.47-5.725 GHz band, the maximum conducted output power over the frequency band of operation shall not exceed the lesser of 250 mW or 11 dBm + 10 log B, where B is the 26-dB emission bandwidth in MHz. If transmitting antennas of directional gain greater than 6 dBi are used, both the peak transmit power and the peak power spectral density shall be reduced by the amount in dB that the directional gain of the antenna exceeds 6 dBi.

The composite antenna gain is 9.22dBi.

**TEST PROCEDURE**

The test is performed in accordance with FCC Public Notice: APPENDIX A Guidelines for Assessing Unlicensed National Information Infrastructure (U-NII) Devices – Part 15, Subpart E, August 2002.

The transmitter output operates continuously therefore Method # 1 is used.

**RESULTS**

**Limit**

Channel	Frequency (MHz)	Fixed Limit (dBm)	B (MHz)	11 + 10 Log B Limit (dBm)	Antenna Gain (dBi)	Limit (dBm)
Low	5500	24	19.083	23.81	9.22	20.59
Mid	5600	24	18.660	23.71	9.22	20.49
High	5700	24	18.389	23.65	9.22	20.43

**Individual Chain Results**

Channel	Frequency (MHz)	Chain 0 Power (dBm)	Chain 1 Power (dBm)	Total Power (dBm)	Limit (dBm)	Margin (dB)
Low	5500	13.48	11.93	15.78	20.59	-7.11
Mid	5600	12.90	12.24	15.59	20.49	-7.59
High	5700	12.69	12.56	15.64	20.43	-7.74

**CHAIN 0 OUTPUT POWER**

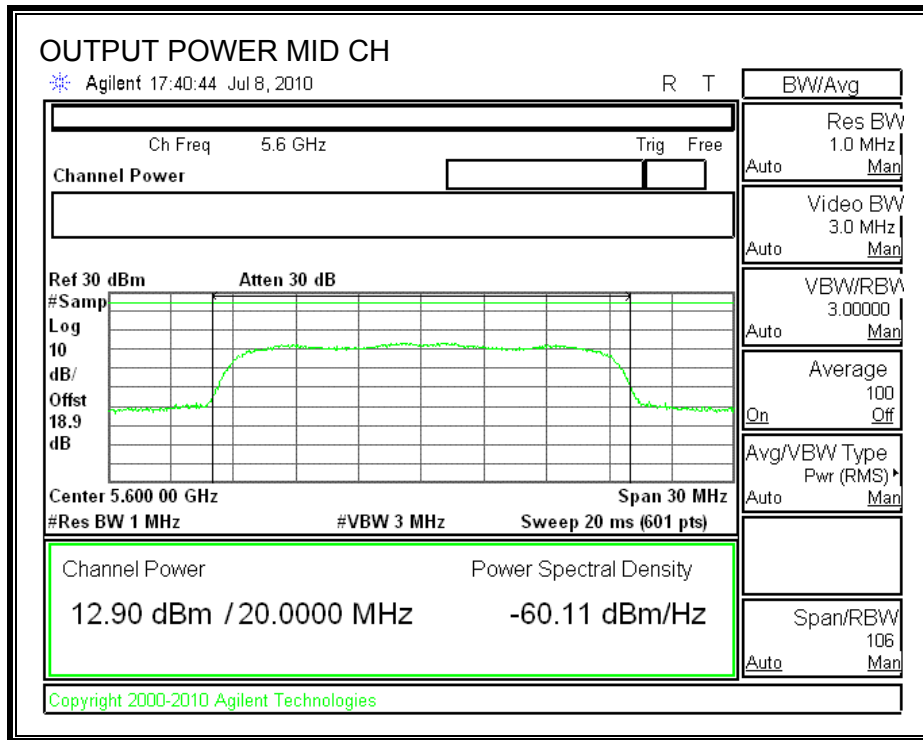
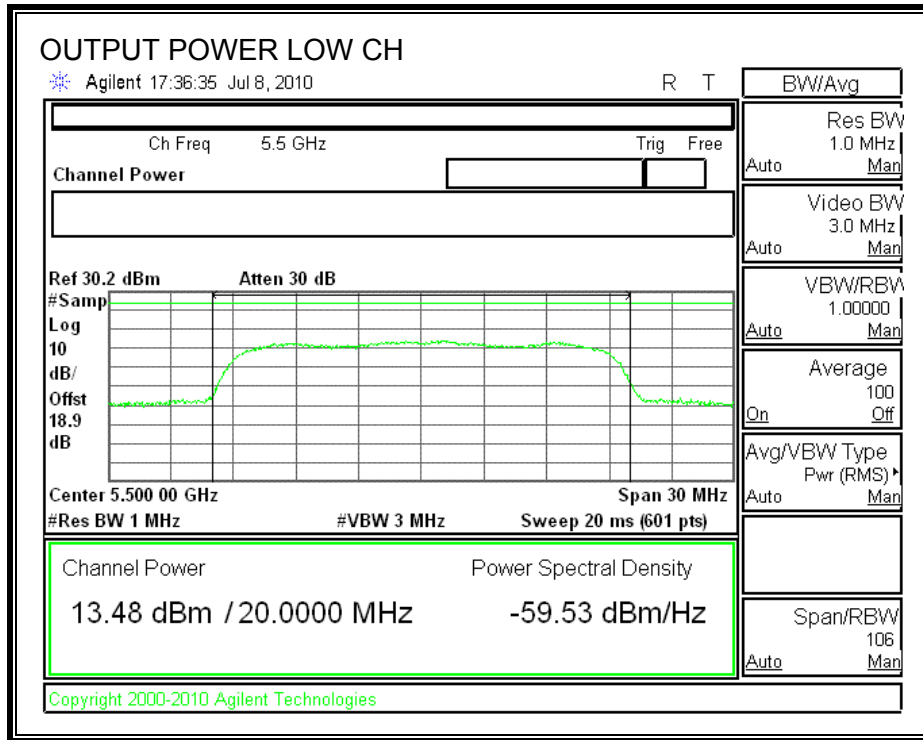

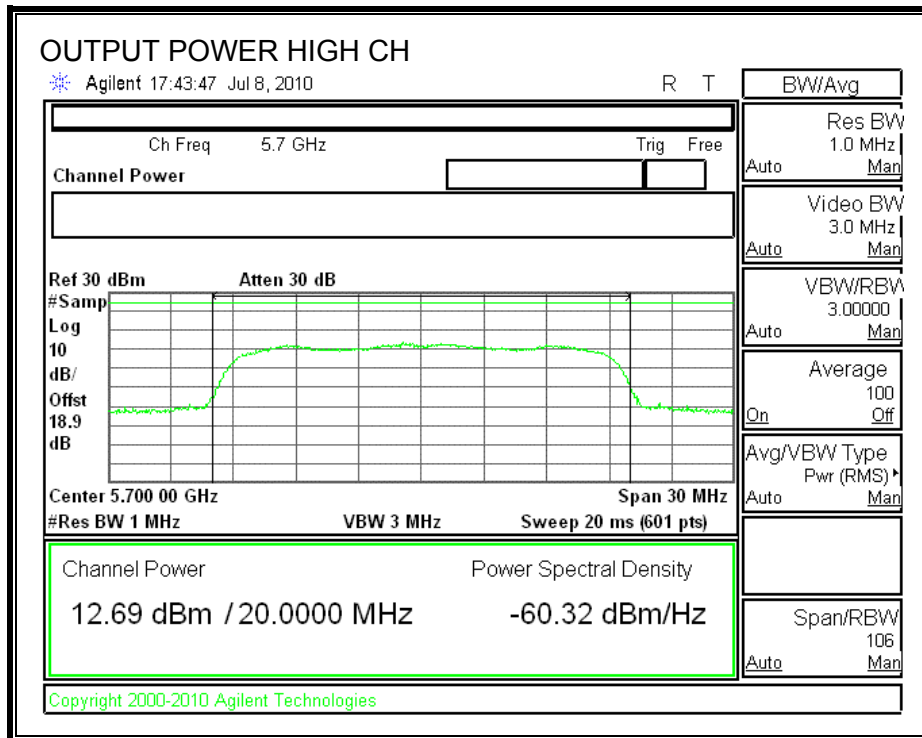

**CHAIN 1 OUTPUT POWER**

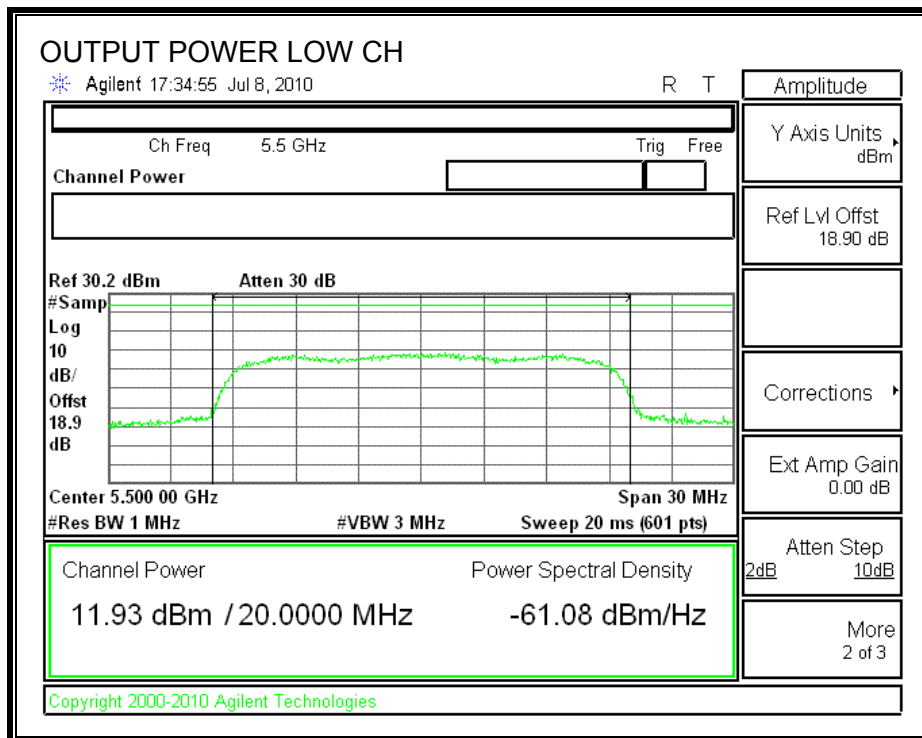

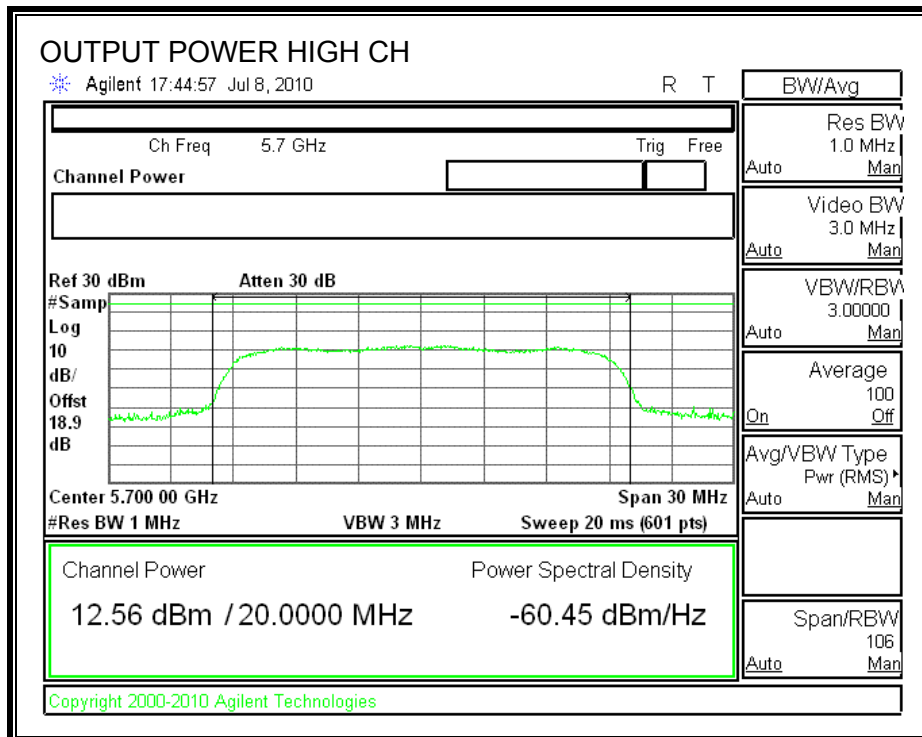
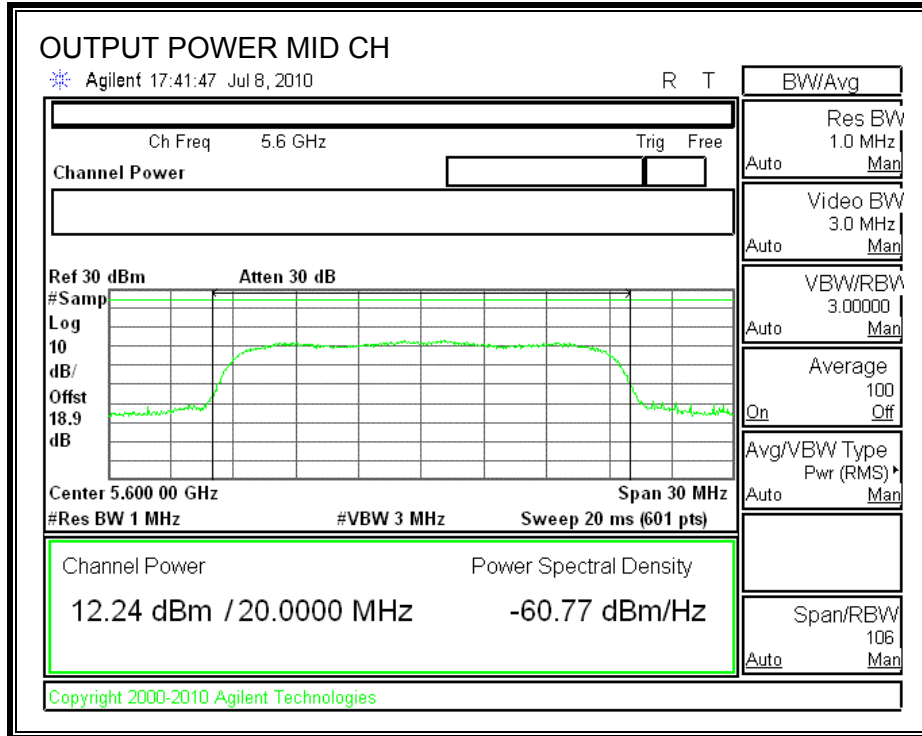

### 7.10.3. PEAK POWER SPECTRAL DENSITY

#### LIMITS

FCC §15.407 (a) (2)

IC RSS-210 A9.2 (2)

For the 5.47-5.725 GHz band, the peak power spectral density shall not exceed 11 dBm in any 1 MHz band. If transmitting antennas of directional gain greater than 6 dBi are used, both the peak transmit power and the peak power spectral density shall be reduced by the amount in dB that the directional gain of the antenna exceeds 6 dBi.

The maximum antenna gain is equal to 9.22 dBi, therefore the limit is 7.78 dBm.

#### TEST PROCEDURE

The test is performed in accordance with FCC Public Notice: APPENDIX A Guidelines for Assessing Unlicensed National Information Infrastructure (U-NII) Devices – Part 15, Subpart E, August 2002. PPSD method #2 was used.

#### RESULTS

Channel	Frequency (MHz)	PPSD With Combiner (dBm)	Limit (dBm)	Margin (dB)
Low	5500	7.58	7.78	-0.20
Middle	5600	7.72	7.78	-0.06
High	5700	7.67	7.78	-0.12

**POWER SPECTRAL DENSITY WITH COMBINER**

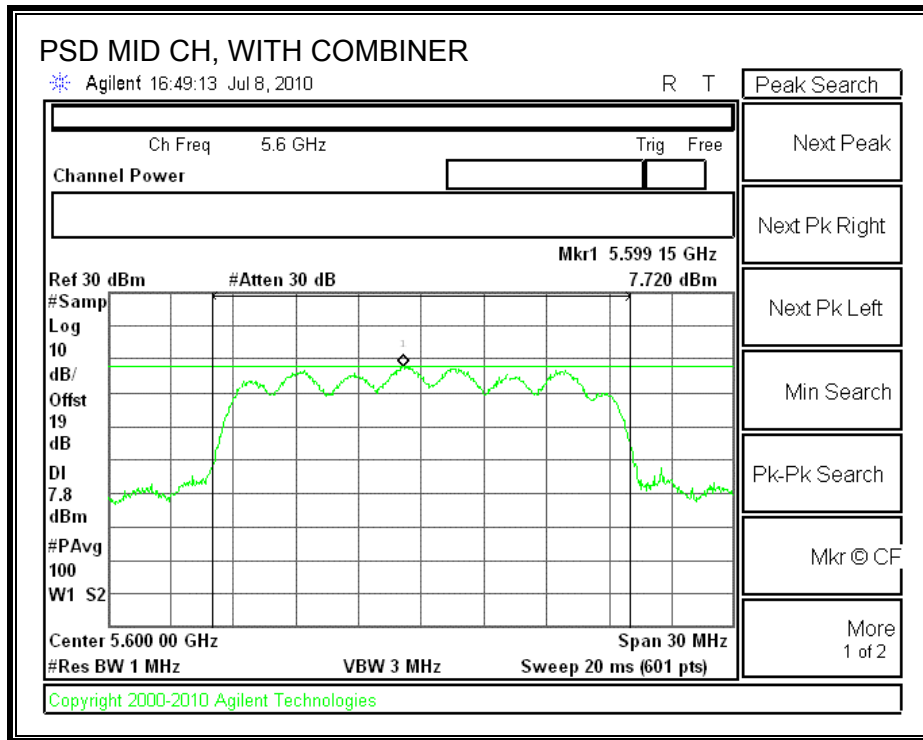
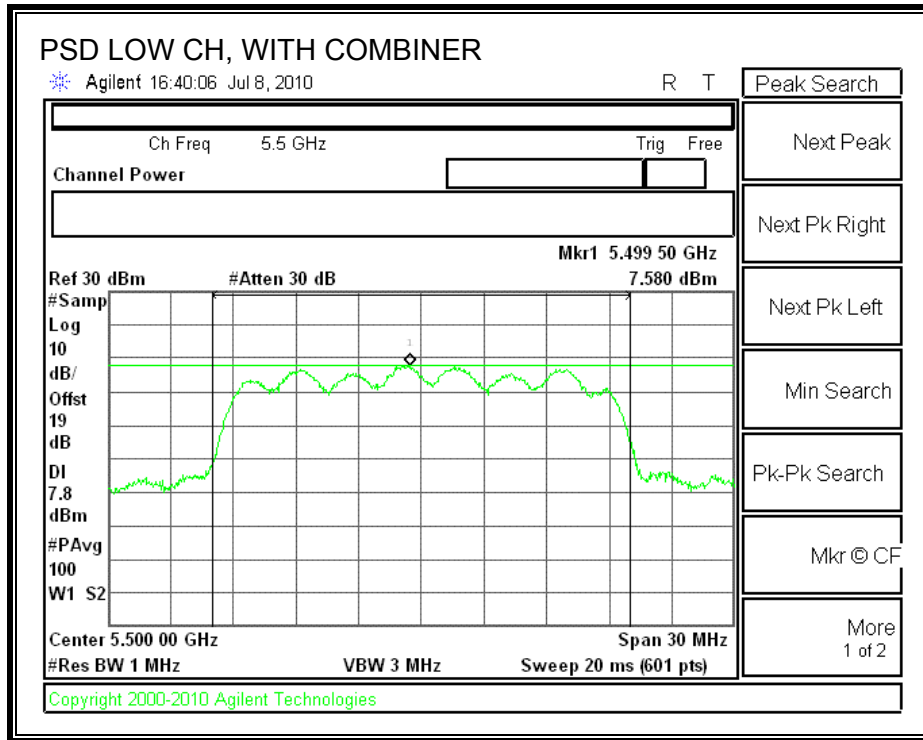

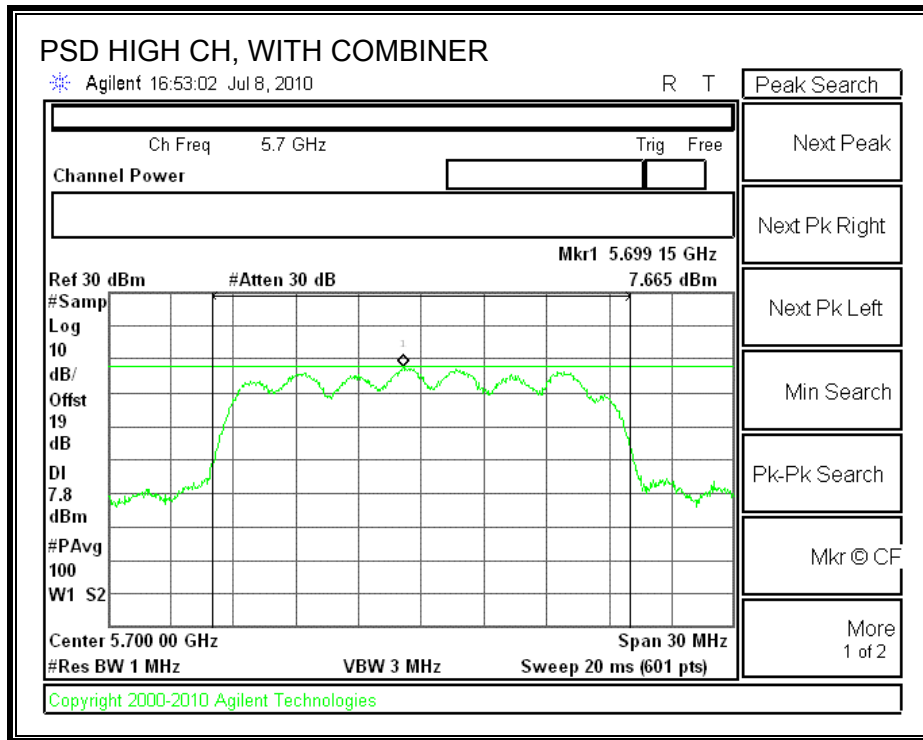

### 7.10.4. PEAK EXCURSION

#### LIMITS

FCC §15.407 (a) (6)

The ratio of the peak excursion of the modulation envelope (measured using a peak hold function) to the peak transmit power (measured as specified above) shall not exceed 13 dB across any 1 MHz bandwidth or the emission bandwidth whichever is less.

#### TEST PROCEDURE

The transmitter outputs are connected to the spectrum analyzer via a combiner.

The test is performed in accordance with FCC Public Notice: APPENDIX A Guidelines for Assessing Unlicensed National Information Infrastructure (U-NII) Devices – Part 15, Subpart E, August 2002.

Since Method # 1 was used for peak power measurements, Method # 1 settings are used for the second PPSD trace.

#### RESULTS

##### CHAIN 0

Channel	Frequency (MHz)	Peak Excursion (dB)	Limit (dB)	Margin (dB)
Low	5500	9.37	13	-3.63
Middle	5600	8.63	13	-4.37
High	5700	8.13	13	-4.87

##### CHAIN 1

Channel	Frequency (MHz)	Peak Excursion (dB)	Limit (dB)	Margin (dB)
Low	5500	9.94	13	-3.06
Middle	5600	9.50	13	-3.50
High	5700	9.60	13	-3.40



**CHAIN 0**

**PEAK EXCURSION**

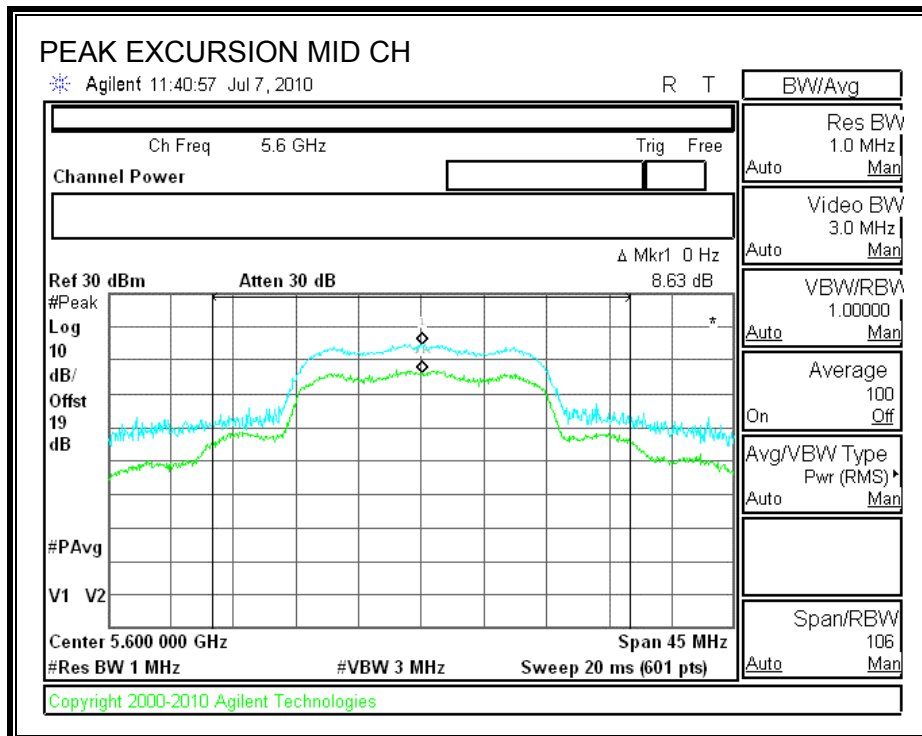
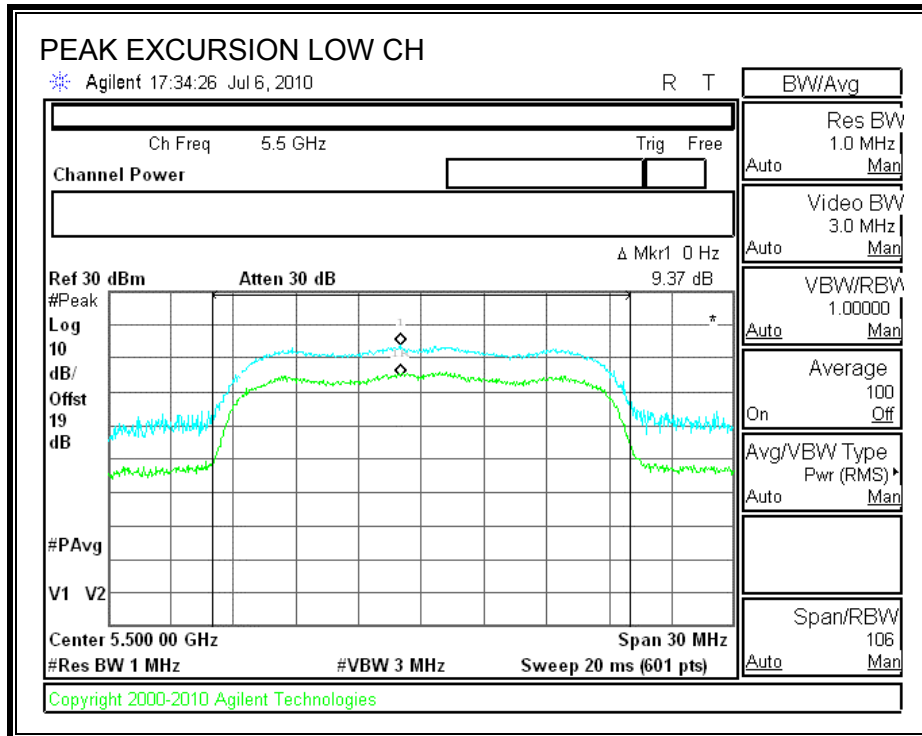

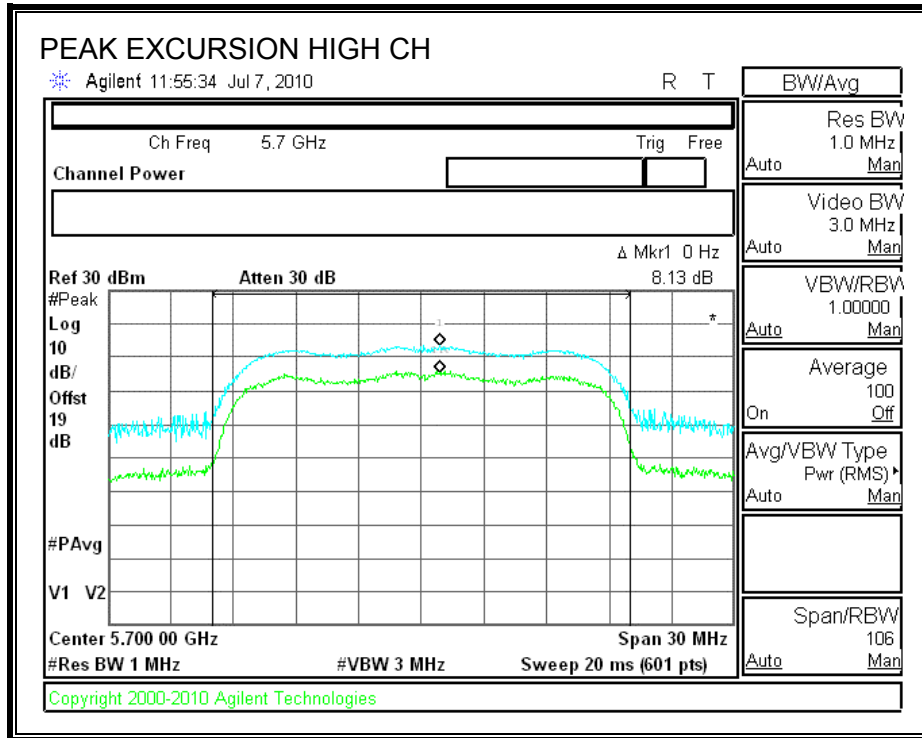

**CHAIN 1**

**PEAK EXCURSION**

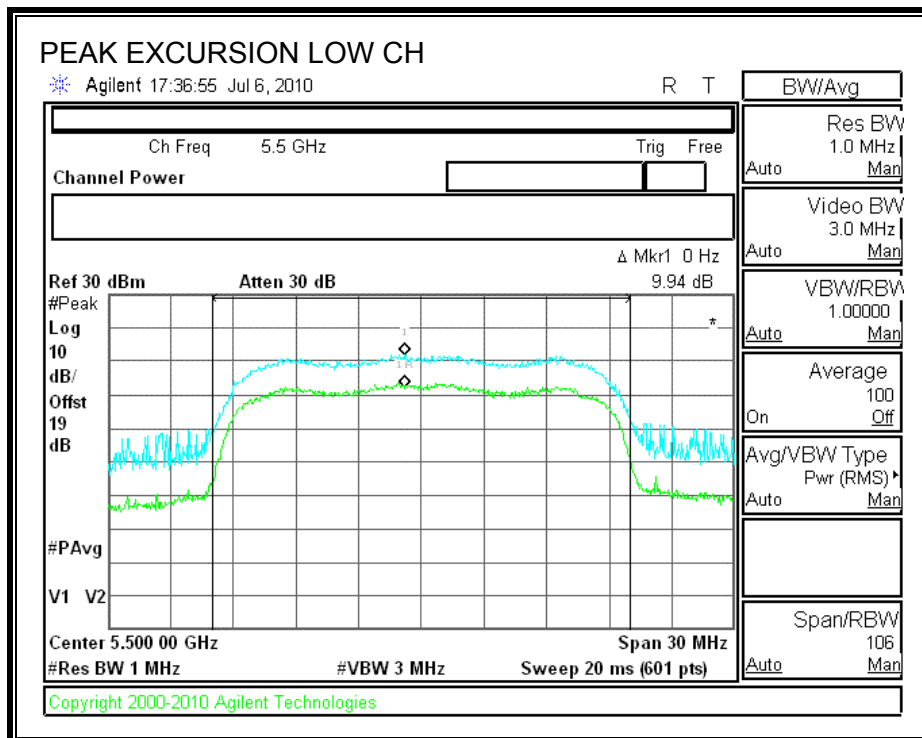

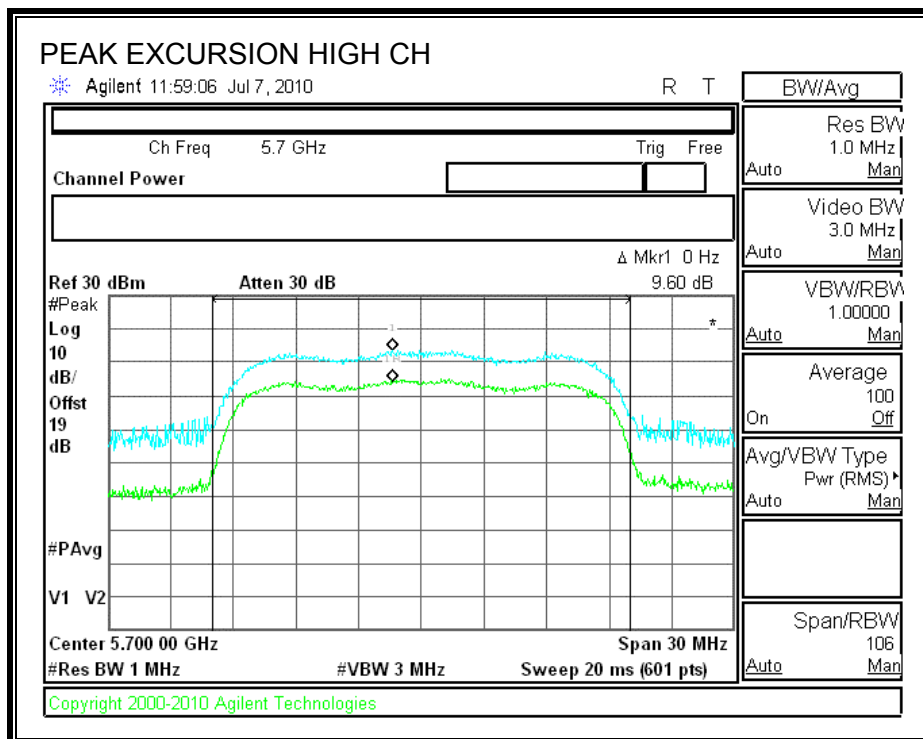
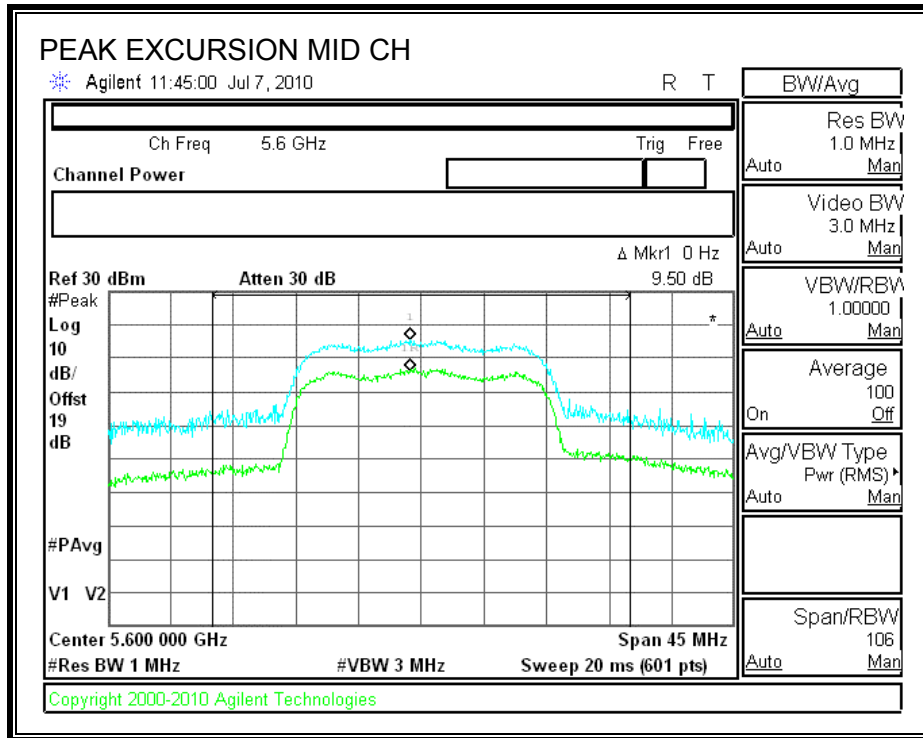

## 7.10.5. CONDUCTED SPURIOUS EMISSIONS

### LIMITS

FCC §15.407 (b) (3)

IC RSS-210 A9.3 (3)

For transmitters operating in the 5.47-5.725 GHz band: all emissions outside of the 5.47-5.725 GHz band shall not exceed an EIRP of -27 dBm / MHz.

### TEST PROCEDURE

Conducted RF measurements of the transmitter output are made to confirm that the EUT antenna port conducted emissions meet the specified limit and to identify any spurious signals that require further investigation or measurements on the radiated emissions site.

The transmitter output is connected to the spectrum analyzer. The resolution bandwidth is set to 1 MHz. The video bandwidth is set to 1MHz. Peak detection measurements are compared to EIRP limit, adjusted for the maximum antenna gain.

Measurements are made over the 30 MHz to 40 GHz range with the transmitter set to the lowest, middle, and highest channels.

**SPURIOUS EMISSIONS WITH COMBINER**

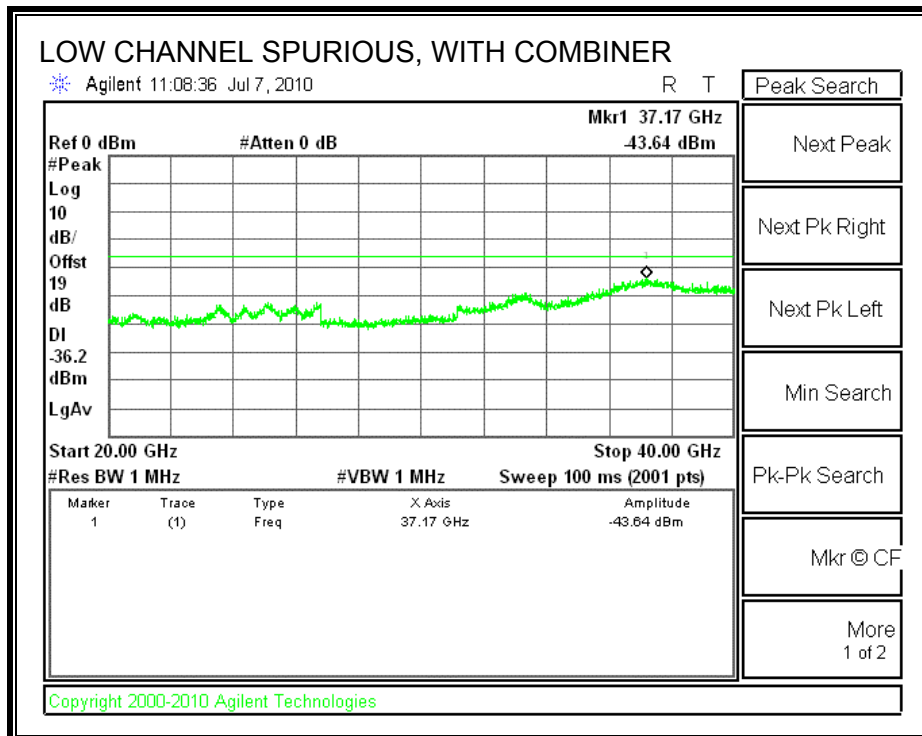
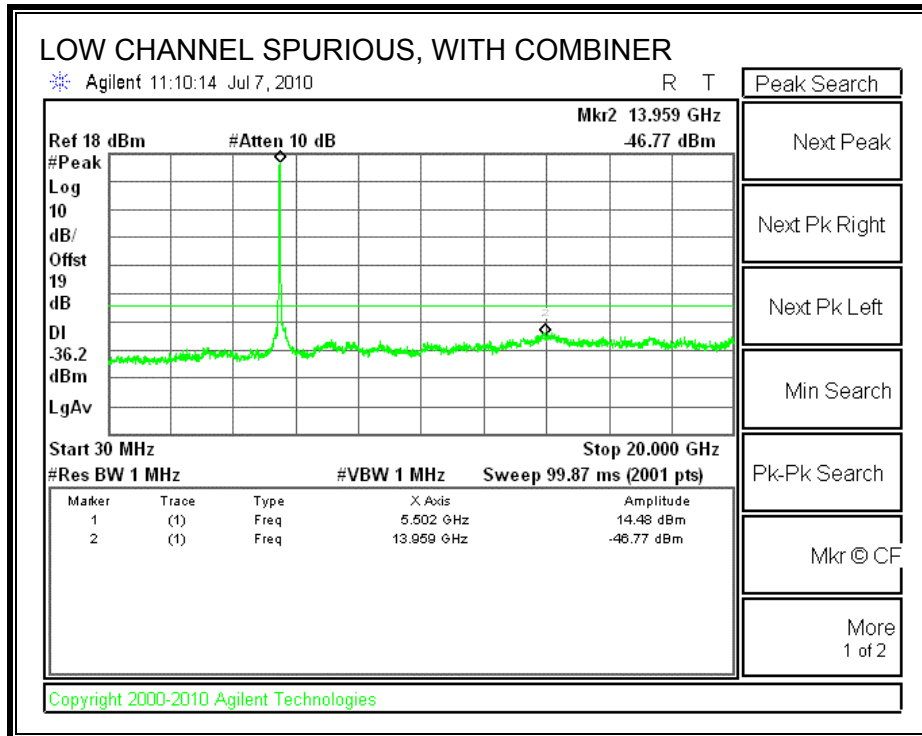

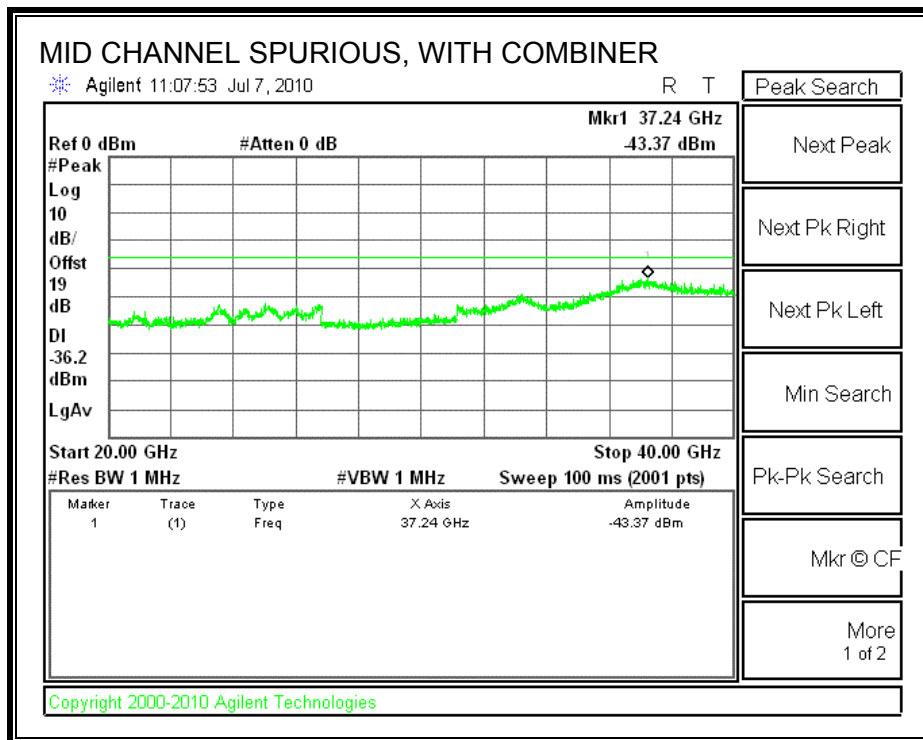
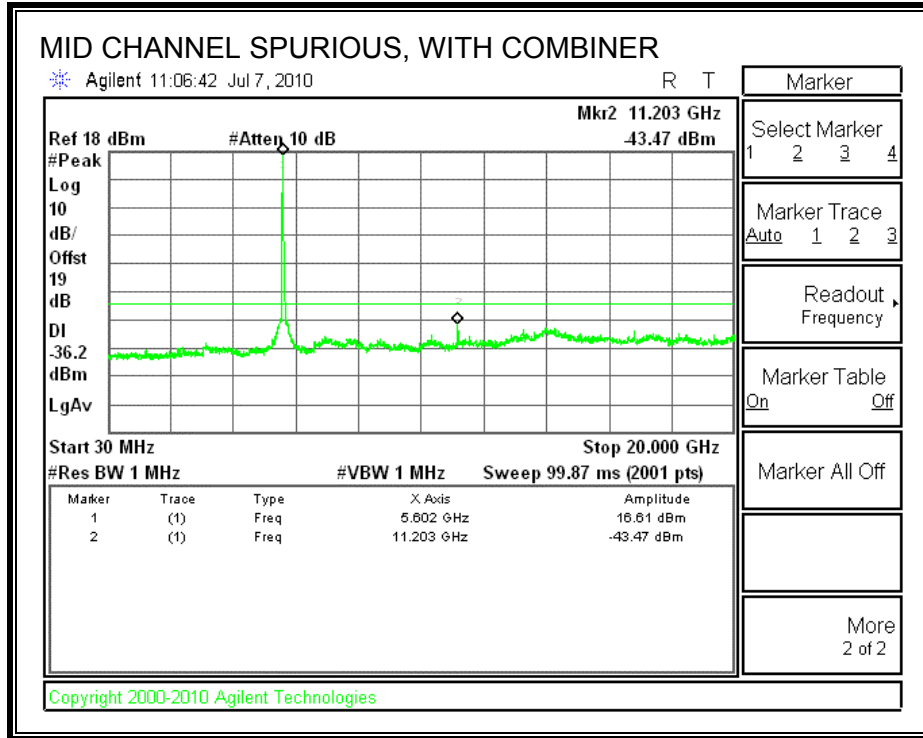

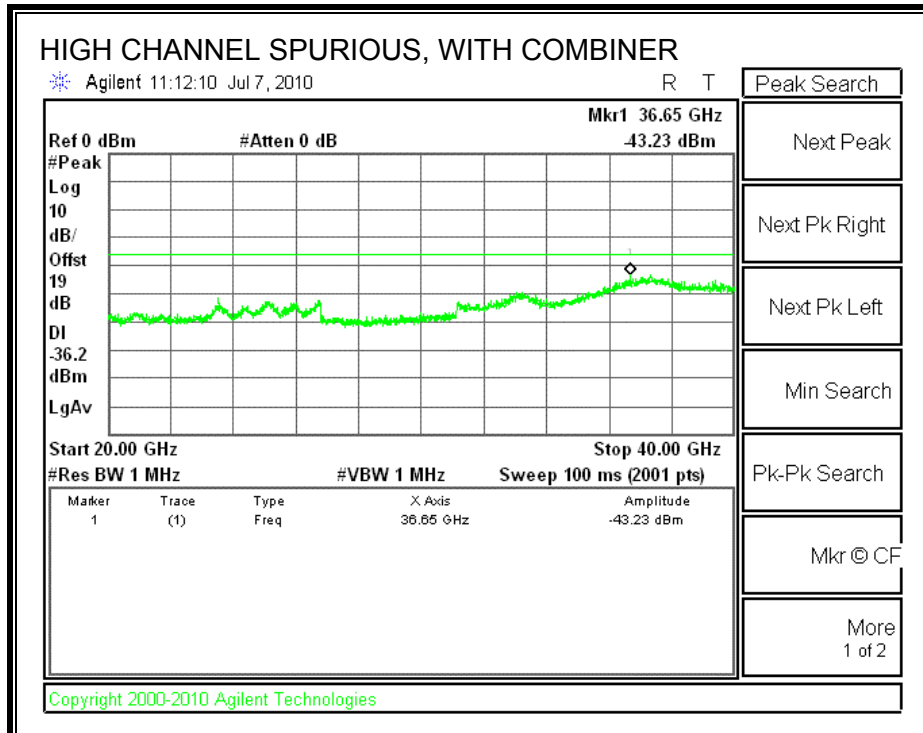
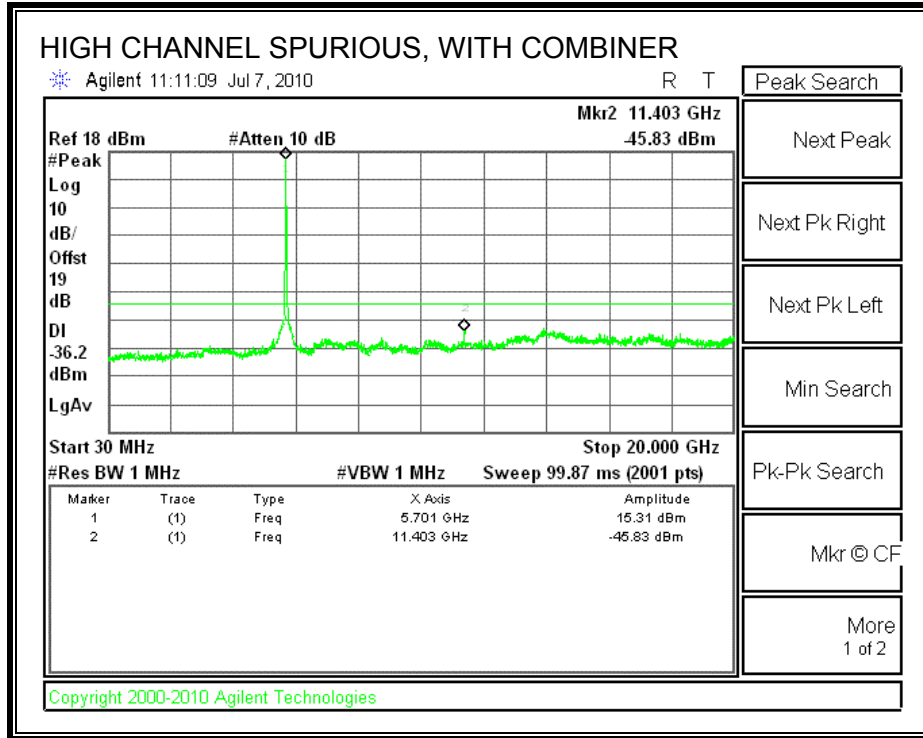

## 7.11. 802.11n HT40 SISO MODE IN THE 5.6 GHz BAND

### 7.11.1. 26 dB and 99% BANDWIDTH

#### LIMITS

None; for reporting purposes only.

#### TEST PROCEDURE

The transmitter outputs are connected to the spectrum analyzer via a combiner. The RBW is set to 1% to 3% of the measured bandwidth. The VBW is set to 3 times the RBW. The sweep time is coupled. The spectrum analyzer internal bandwidth function is utilized.

#### RESULTS

Channel	Frequency (MHz)	26 dB Bandwidth (MHz)	99% Bandwidth (MHz)
Low	5510	73.662	36.9773
Mid	5590	76.597	53.9747
High	5670	72.970	36.5033



**26 dB and 99% BANDWIDTH**

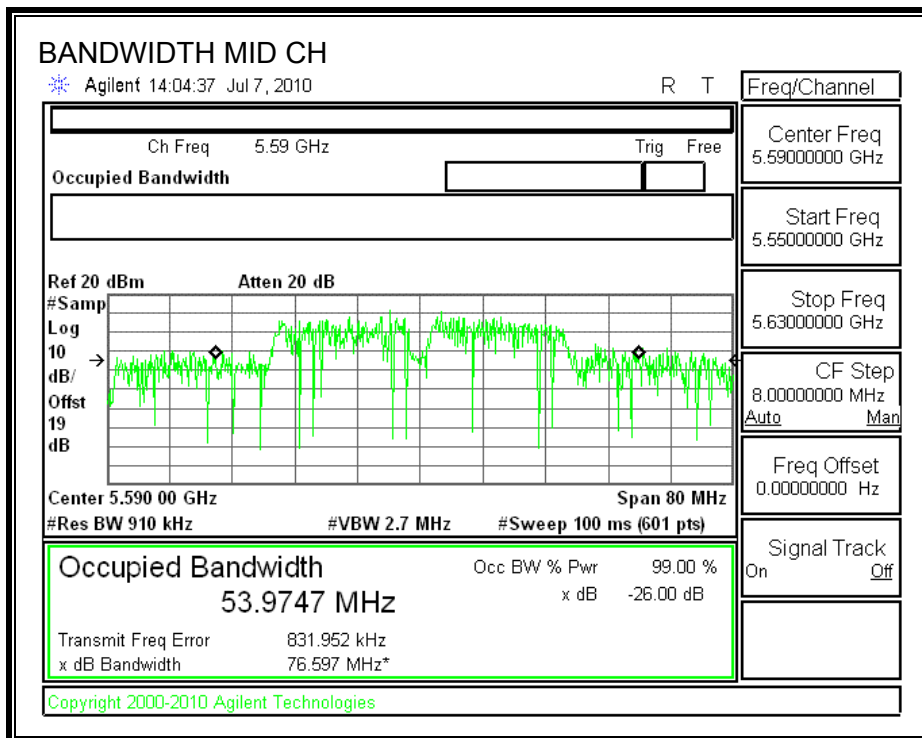
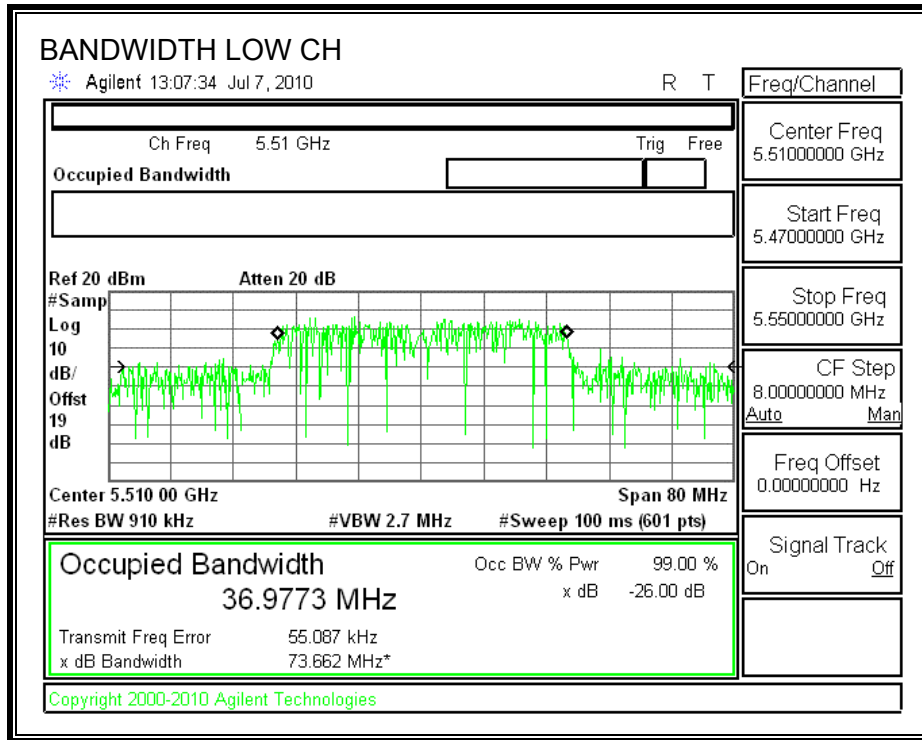

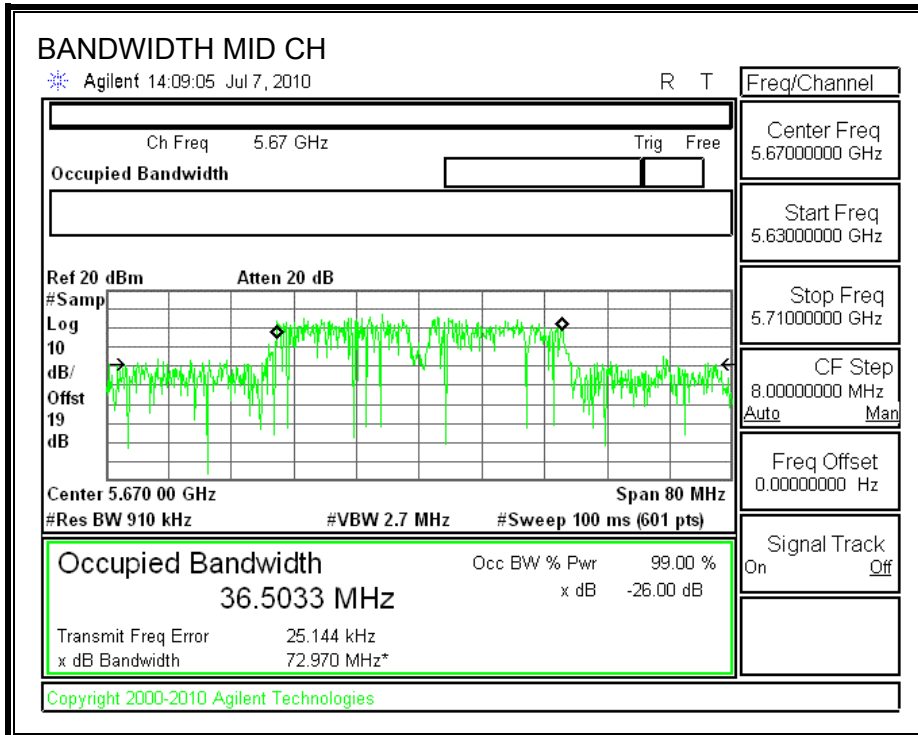

## 7.11.2. OUTPUT POWER

### LIMITS

FCC §15.407 (a) (1)

IC RSS-210 A9.2 (1)

For the 5.47-5.725 GHz band, the maximum conducted output power over the frequency band of operation shall not exceed the lesser of 250 mW or 11 dBm + 10 log B, where B is the 26-dB emission bandwidth in MHz. If transmitting antennas of directional gain greater than 6 dBi are used, both the peak transmit power and the peak power spectral density shall be reduced by the amount in dB that the directional gain of the antenna exceeds 6 dBi.

The maximum antenna gain is 6.61 dBi.

### TEST PROCEDURE

The test is performed in accordance with FCC Public Notice: APPENDIX A Guidelines for Assessing Unlicensed National Information Infrastructure (U-NII) Devices – Part 15, Subpart E, August 2002.

The transmitter output operates continuously therefore Method # 1 is used.

### RESULTS

#### Limit

Channel	Frequency (MHz)	Fixed Limit (dBm)	B (MHz)	11 + 10 Log B Limit (dBm)	Antenna Gain (dBi)	Limit (dBm)
Low	5510	24	73.662	22.67	6.61	22.06
Low	5590	24	76.597	22.84	6.61	22.23
High	5670	24	72.970	22.63	6.61	22.02

#### Results

Channel	Frequency (MHz)	Power (dBm)	Limit (dBm)	Margin (dB)
Low	5510	13.65	22.06	-8.41
Low	5590	18.16	22.23	-4.07
High	5670	15.19	22.02	-6.83

**OUTPUT POWER**

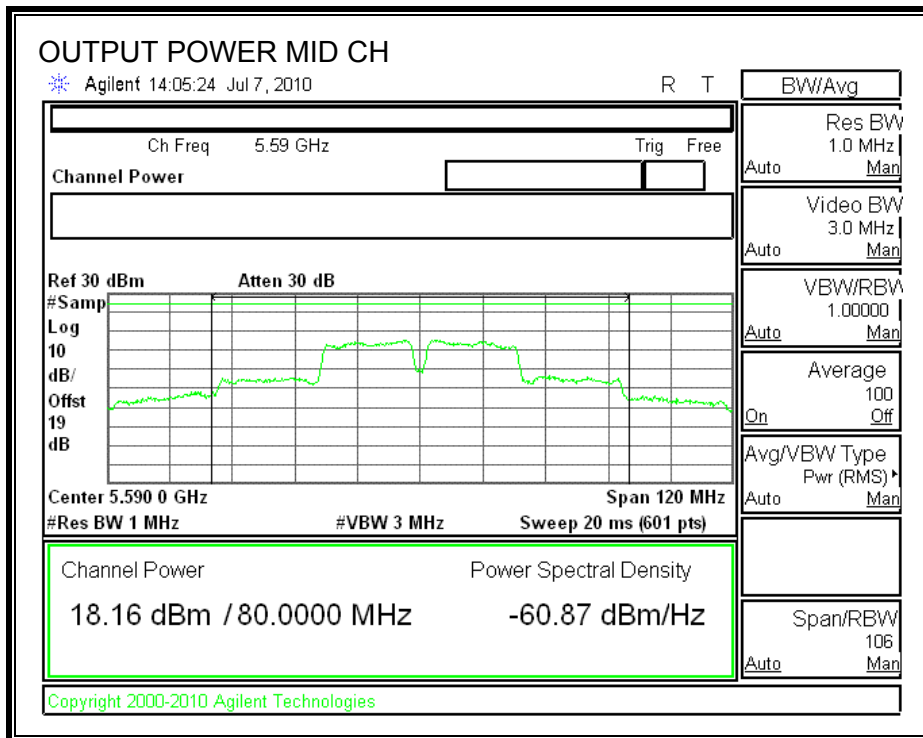
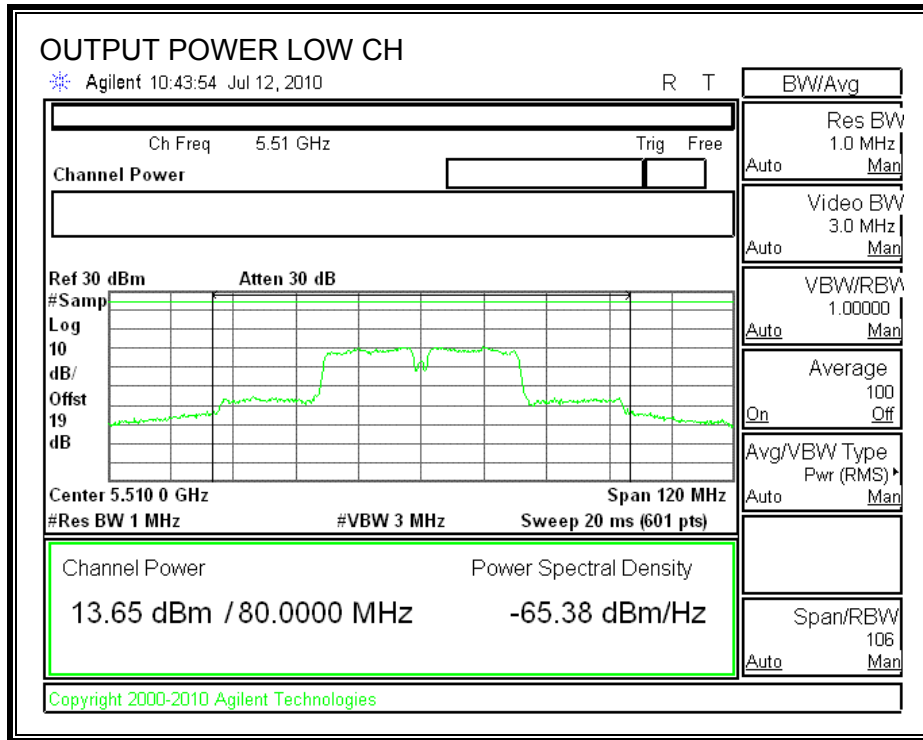

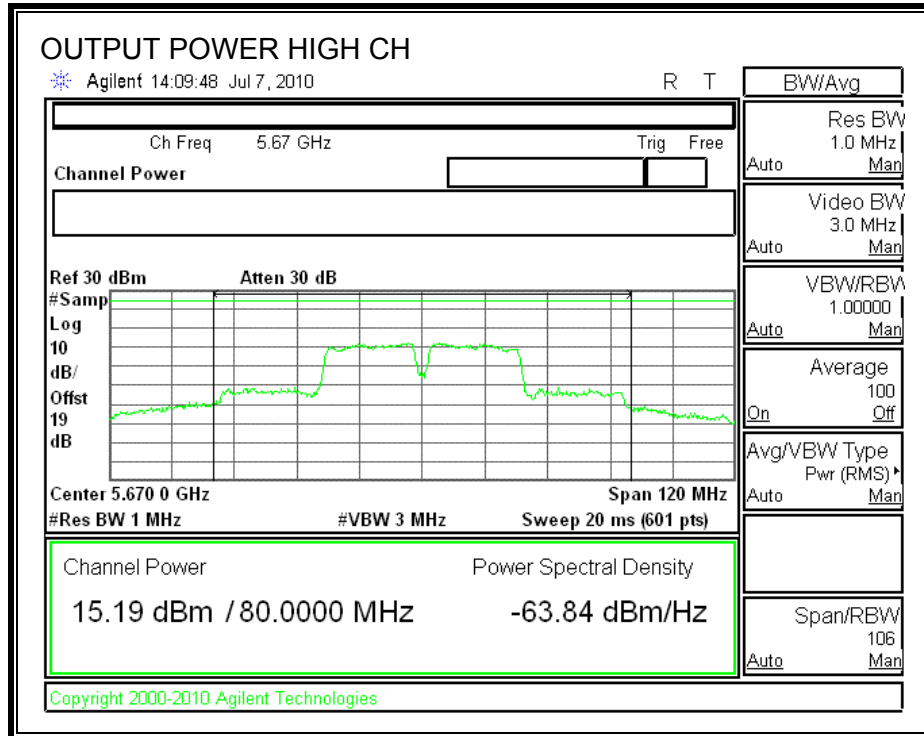

### 7.11.3. PEAK POWER SPECTRAL DENSITY

#### LIMITS

FCC §15.407 (a) (1)

IC RSS-210 A9.2 (1)

For the 5.47-5.725 GHz band, the peak power spectral density shall not exceed 11 dBm in any 1 MHz band. If transmitting antennas of directional gain greater than 6 dBi are used, both the peak transmit power and the peak power spectral density shall be reduced by the amount in dB that the directional gain of the antenna exceeds 6 dBi.

The composite antenna gain is 6.61 dBi, therefore the limit is 10.39 dBm.

#### TEST PROCEDURE

The test is performed in accordance with FCC Public Notice: APPENDIX A Guidelines for Assessing Unlicensed National Information Infrastructure (U-NII) Devices – Part 15, Subpart E, August 2002. PPSD method #2 was used.

#### RESULTS

Channel	Frequency (MHz)	PPSD (dBm)	Limit (dBm)	Margin (dB)
Low	5510	0.60	10.39	-9.79
Mid	5590	5.45	10.39	-4.94
High	5670	1.82	10.39	-8.57

**POWER SPECTRAL DENSITY**

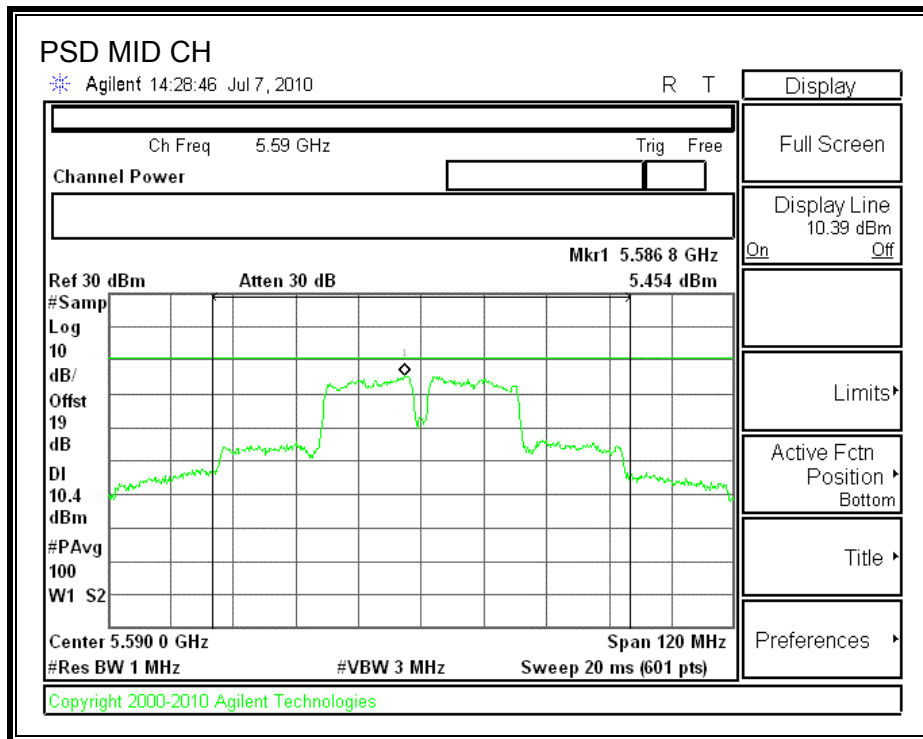
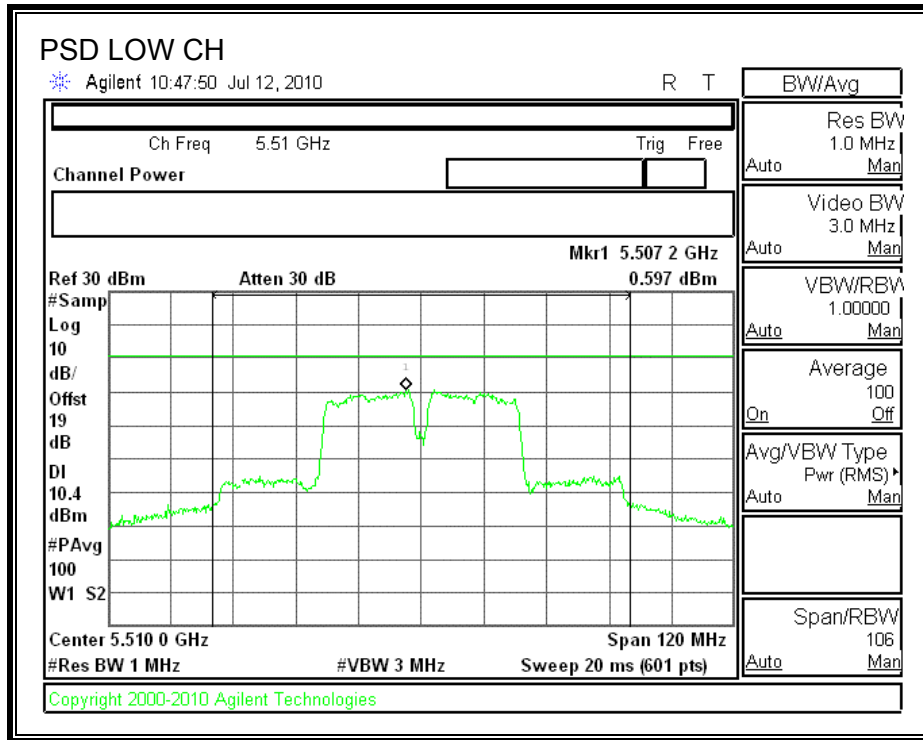

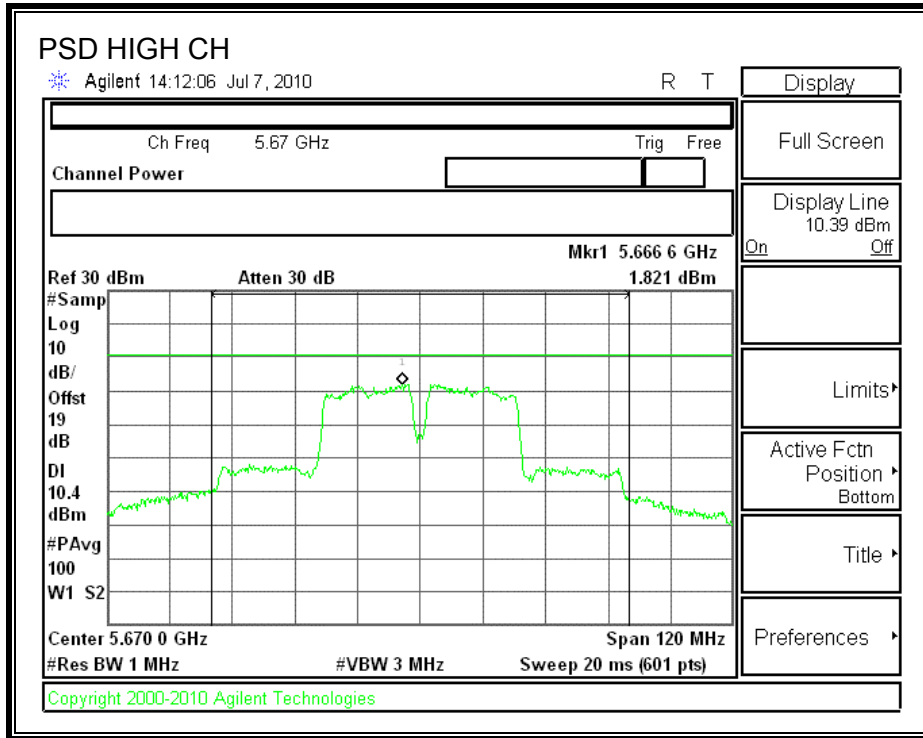



#### 7.11.4. PEAK EXCURSION

##### LIMITS

FCC §15.407 (a) (6)

The ratio of the peak excursion of the modulation envelope (measured using a peak hold function) to the peak transmit power (measured as specified above) shall not exceed 13 dB across any 1 MHz bandwidth or the emission bandwidth whichever is less.

##### TEST PROCEDURE

The transmitter outputs are connected to the spectrum analyzer via a combiner.

The test is performed in accordance with FCC Public Notice: APPENDIX A Guidelines for Assessing Unlicensed National Information Infrastructure (U-NII) Devices – Part 15, Subpart E, August 2002.

Since Method # 1 was used for peak power measurements, Method # 1 settings are used for the second PPSD trace.

##### RESULTS

###### CHAIN 1

Channel	Frequency (MHz)	Peak Excursion (dB)	Limit (dB)	Margin (dB)
Low	5510	7.45	13	-5.55
Mid	5590	8.42	13	-4.58
High	5670	7.69	13	-5.31

**PEAK EXCURSION**

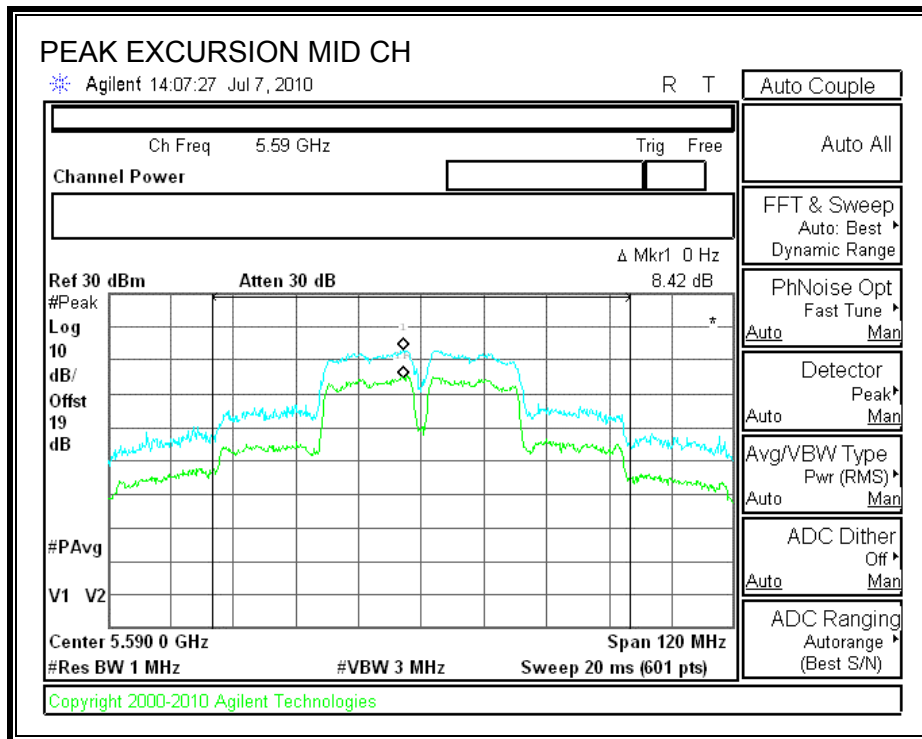
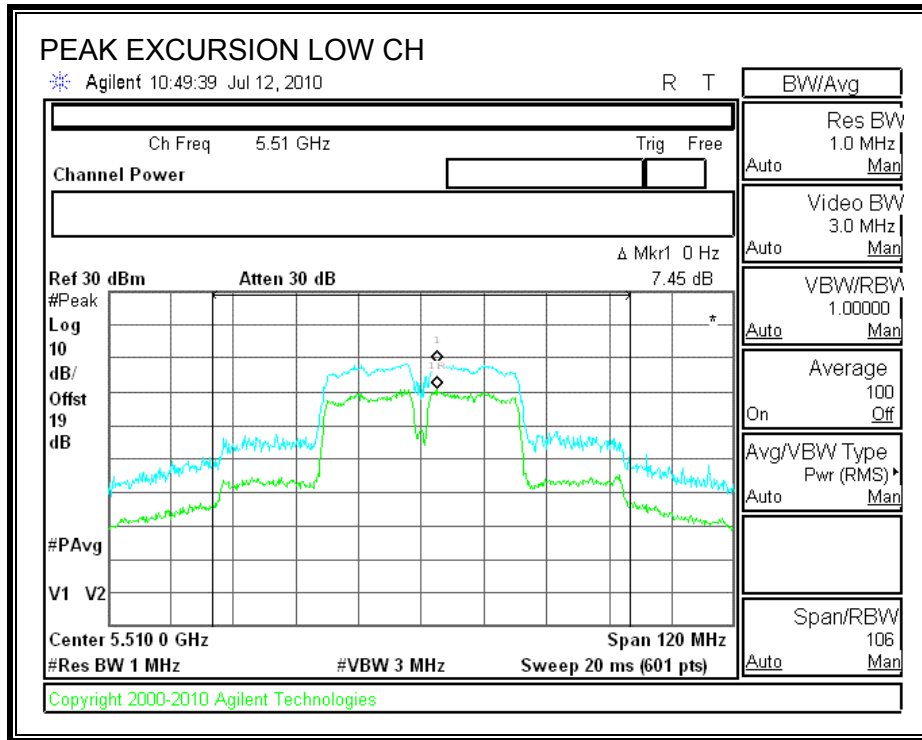

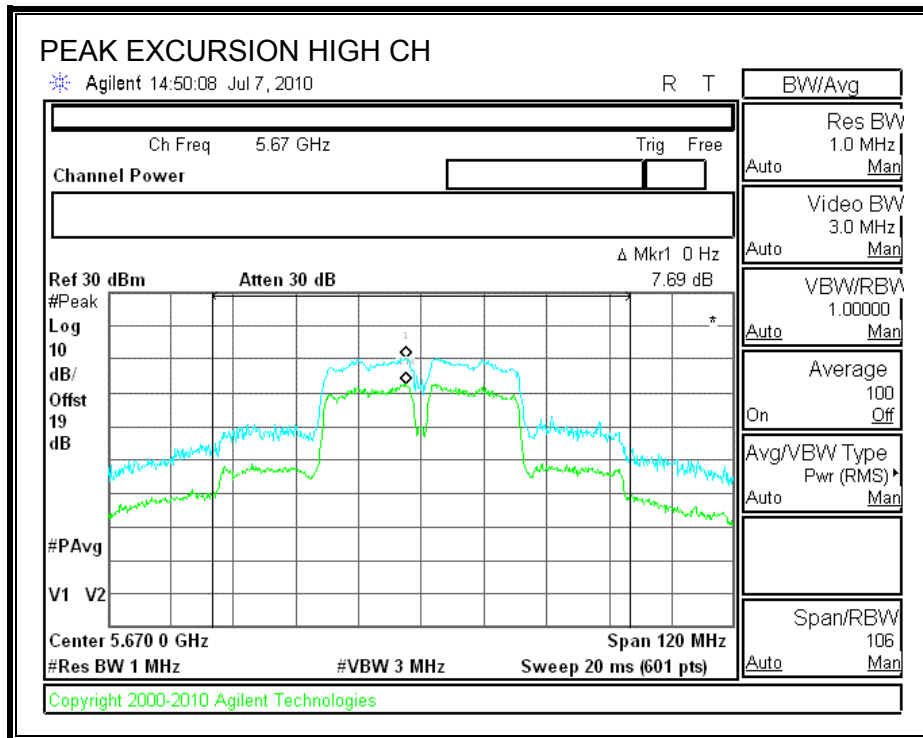

### 7.11.5. CONDUCTED SPURIOUS EMISSIONS

#### LIMITS

FCC §15.407 (b) (1)

IC RSS-210 A9.3 (1)

For transmitters operating in the 5.47-5.725 GHz band: all emissions outside of the 5.47-5.725 GHz band shall not exceed an EIRP of -27 dBm / MHz.

#### TEST PROCEDURE

Conducted RF measurements of the transmitter output are made to confirm that the EUT antenna port conducted emissions meet the specified limit and to identify any spurious signals that require further investigation or measurements on the radiated emissions site.

The transmitter output is connected to the spectrum analyzer. The resolution bandwidth is set to 1 MHz. The video bandwidth is set to 1MHz. Peak detection measurements are compared to EIRP limit, adjusted for the maximum antenna gain.

Measurements are made over the 30 MHz to 40 GHz range with the transmitter set to the lowest, middle, and highest channels.

**SPURIOUS EMISSIONS**

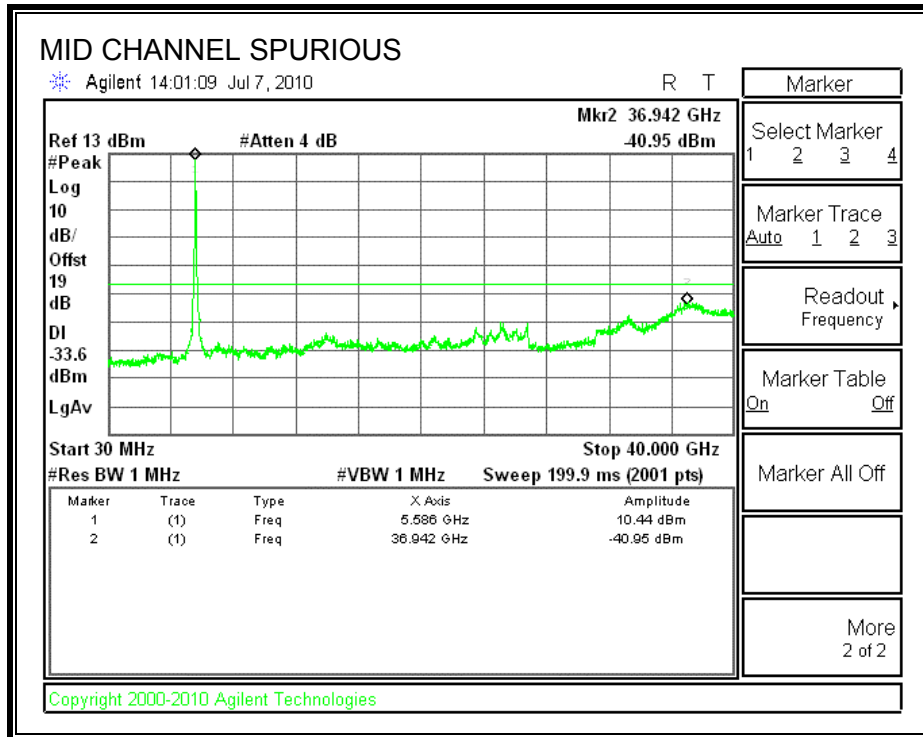
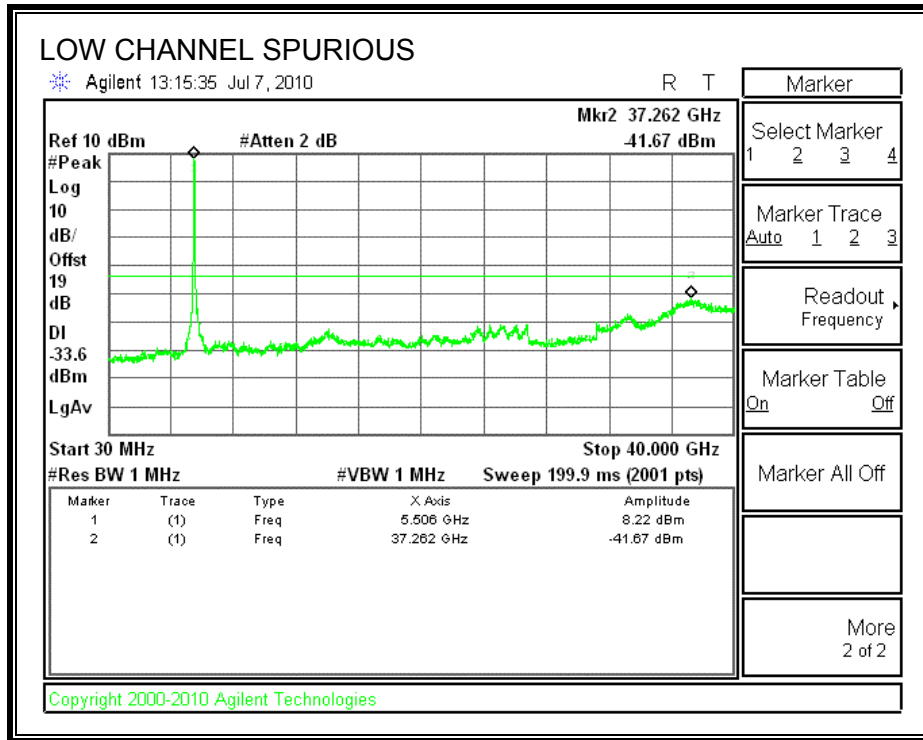

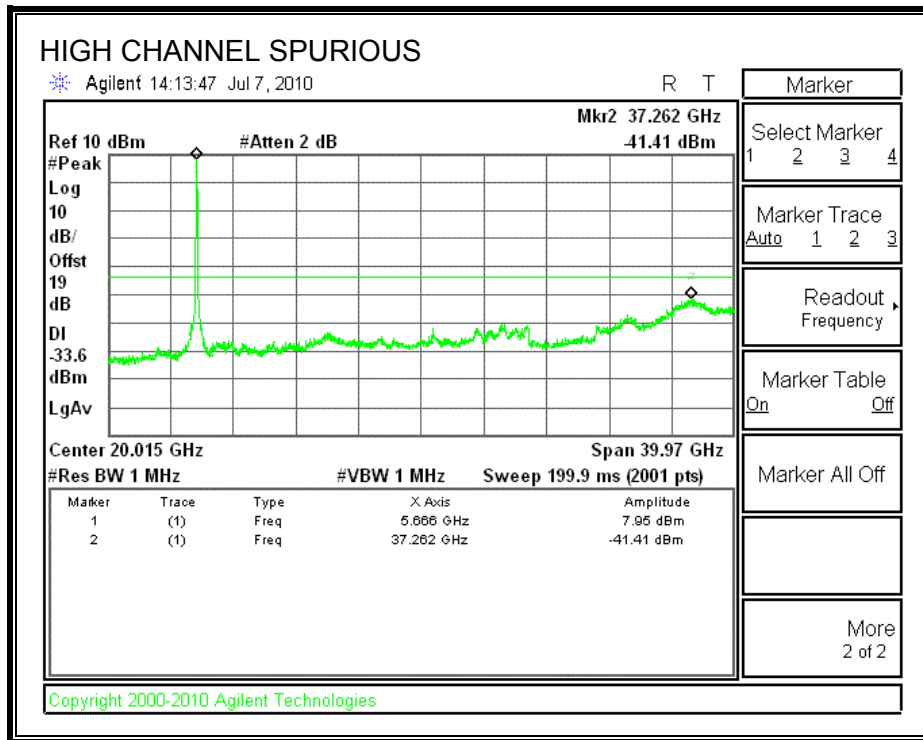

## 7.12. 802.11n HT40 MODE IN THE 5.6 GHz BAND

### 7.12.1. 26 dB and 99% BANDWIDTH

#### LIMITS

None; for reporting purposes only.

#### TEST PROCEDURE

The transmitter outputs are connected to the spectrum analyzer via a combiner. The RBW is set to 1% to 3% of the measured bandwidth. The VBW is set to 3 times the RBW. The sweep time is coupled. The spectrum analyzer internal bandwidth function is utilized.

#### RESULTS

##### CHAIN 0

Channel	Frequency (MHz)	26 dB Bandwidth (MHz)	99% Bandwidth (MHz)
Low	5510	50.398	36.4490
Middle	5590	76.886	37.6821
High	5670	75.343	37.1161

##### CHAIN 1

Channel	Frequency (MHz)	26 dB Bandwidth (MHz)	99% Bandwidth (MHz)
Low	5510	38.004	36.2810
Middle	5590	74.138	37.2471
High	5670	75.740	36.9805

**CHAIN 0**

**26 dB and 99% BANDWIDTH**

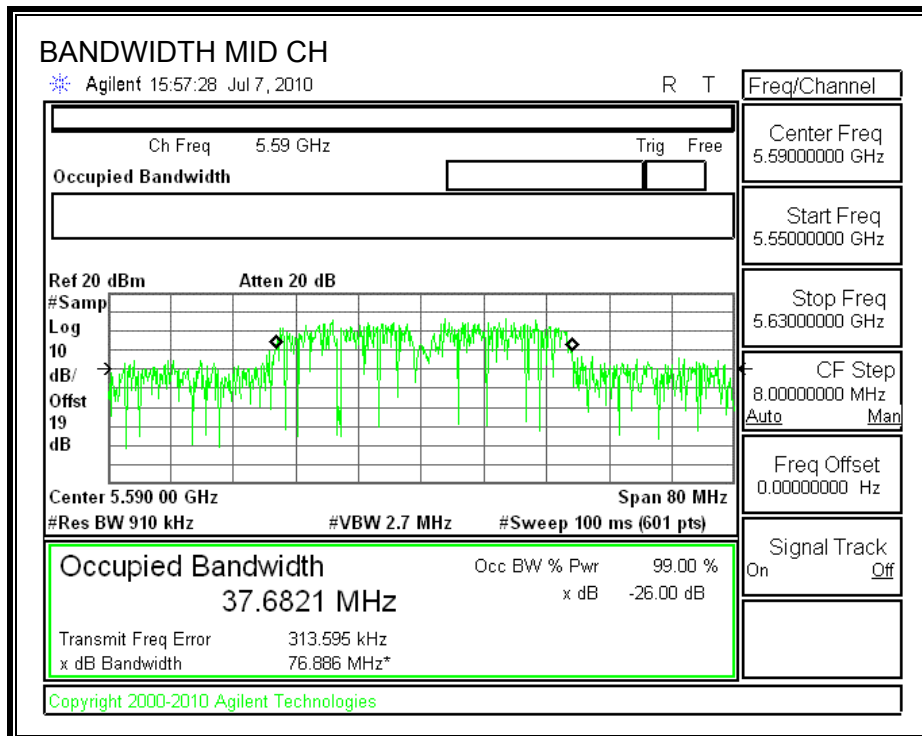
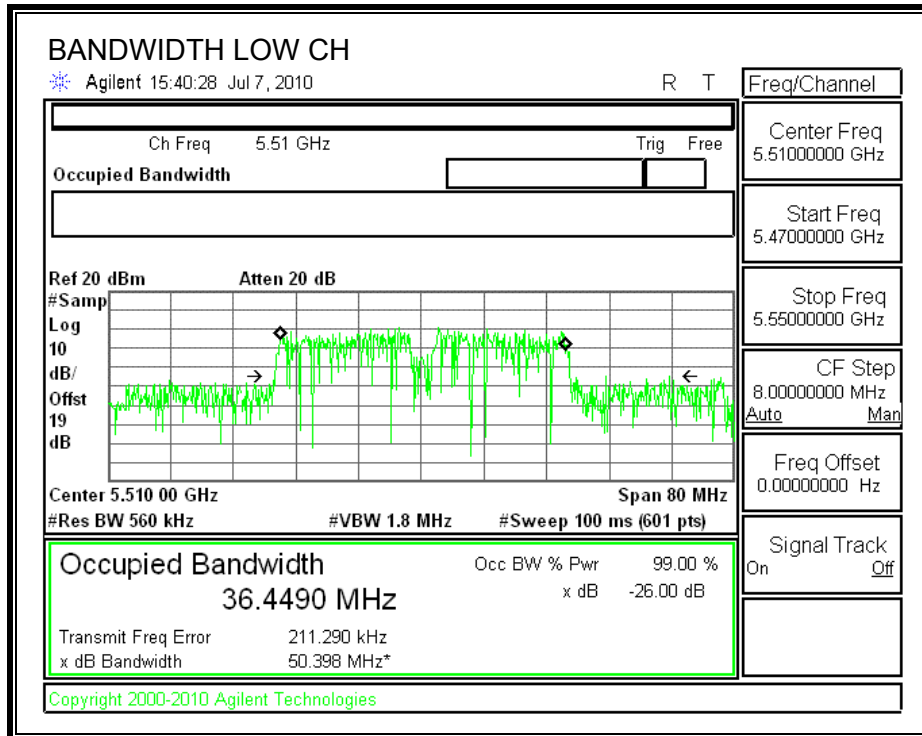



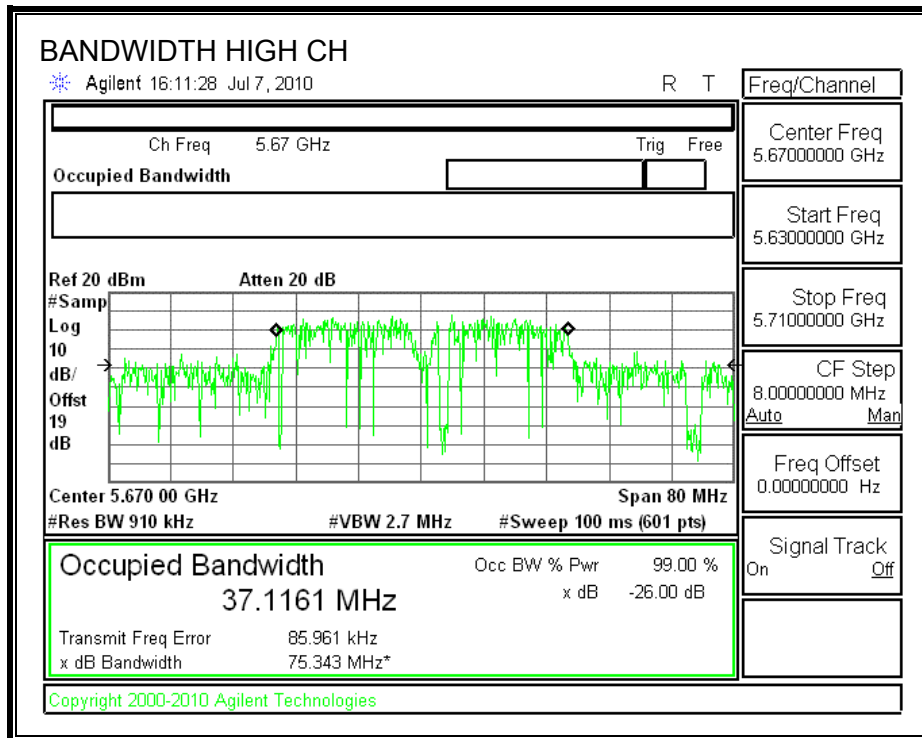

**CHAIN 1**

**26 dB and 99% BANDWIDTH**

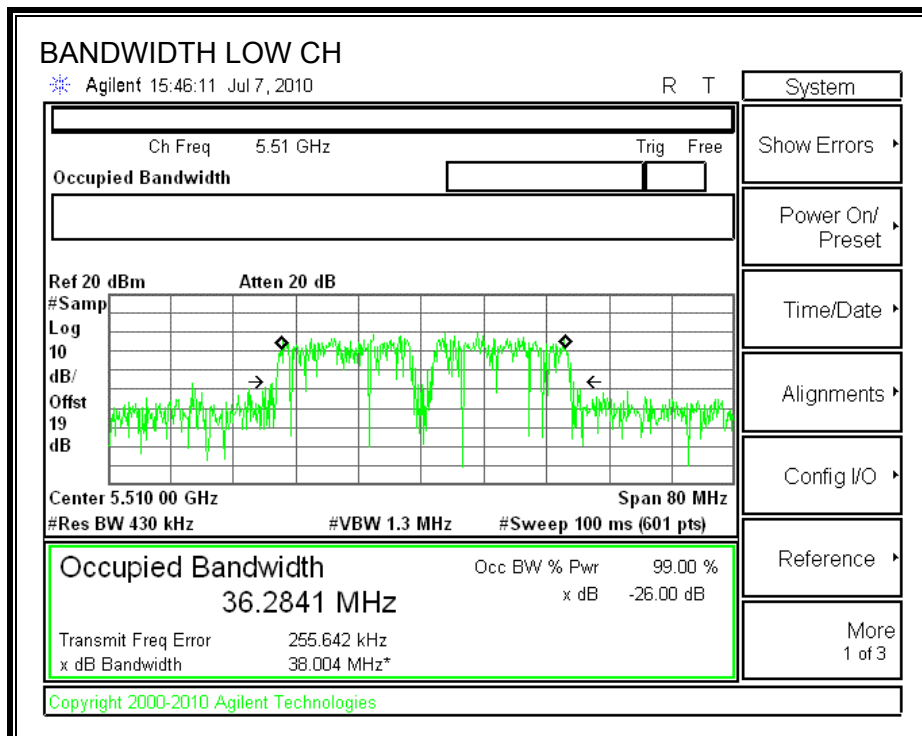

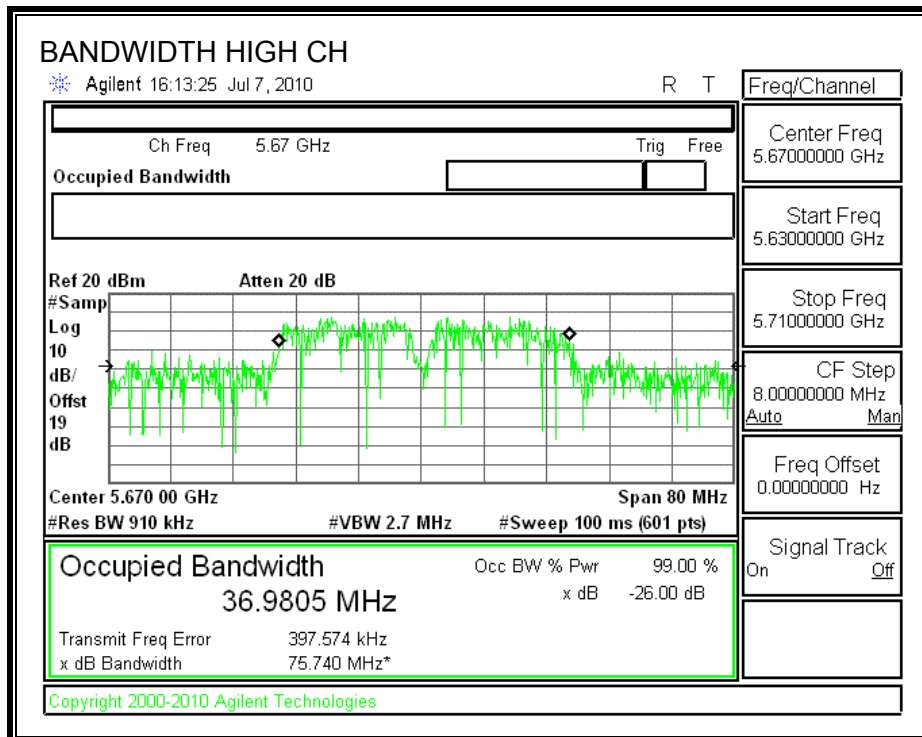
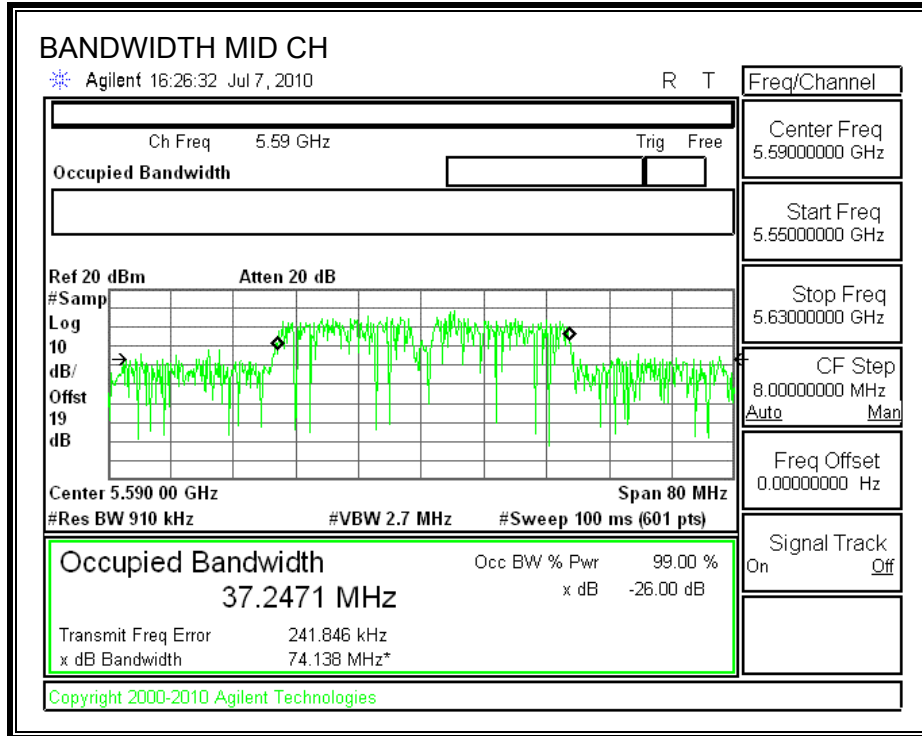

## 7.12.2. OUTPUT POWER

### LIMITS

FCC §15.407 (a) (2)  
 IC RSS-210 A9.2 (2)

For the 5.47-5.725 GHz band, the maximum conducted output power over the frequency band of operation shall not exceed the lesser of 250 mW or  $11 \text{ dBm} + 10 \log B$ , where B is the 26-dB emission bandwidth in MHz. If transmitting antennas of directional gain greater than 6 dBi are used, both the peak transmit power and the peak power spectral density shall be reduced by the amount in dB that the directional gain of the antenna exceeds 6 dBi.

The composite antenna gain is 9.22dBi

### TEST PROCEDURE

The test is performed in accordance with FCC Public Notice: APPENDIX A Guidelines for Assessing Unlicensed National Information Infrastructure (U-NII) Devices – Part 15, Subpart E, August 2002.

The transmitter output operates continuously therefore Method # 1 is used.

### RESULTS

#### Limit

Channel	Frequency (MHz)	Fixed Limit (dBm)	B (MHz)	11 + 10 Log B Limit (dBm)	Antenna Gain (dBi)	Limit (dBm)
Low	5510	24	50.398	28.02	9.22	20.78
Mid	5590	24	76.886	29.86	9.22	20.78
High	5670	24	75.343	29.77	9.22	20.78

#### Individual Chain Results

Channel	Frequency (MHz)	Chain 0 Power (dBm)	Chain 1 Power (dBm)	Total Power (dBm)	Limit (dBm)	Margin (dB)
Low	5510	12.56	11.42	15.04	20.78	-8.22
Mid	5590	16.64	17.25	19.97	20.78	-4.14
High	5670	15.61	15.55	18.59	20.78	-5.17

#### TPC Results

TPC Delta Power		Chain 0	Chain 1			
		5.89	5.70			
Worst-case TPC Power		Chain 0	Chain 1	Total Power	Ant Gain	EIRP
Mid	5590	10.75	11.55	14.18	9.22	23.40
TPC Limit (dBm)						24
Margin (dB)						-0.60

**CHAIN 0 OUTPUT POWER**

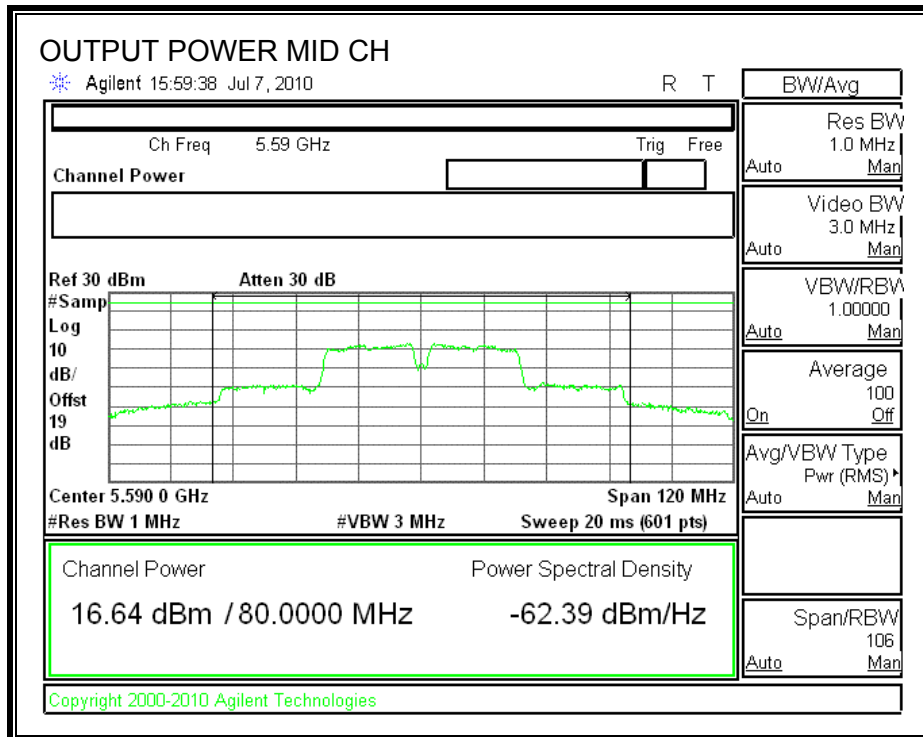
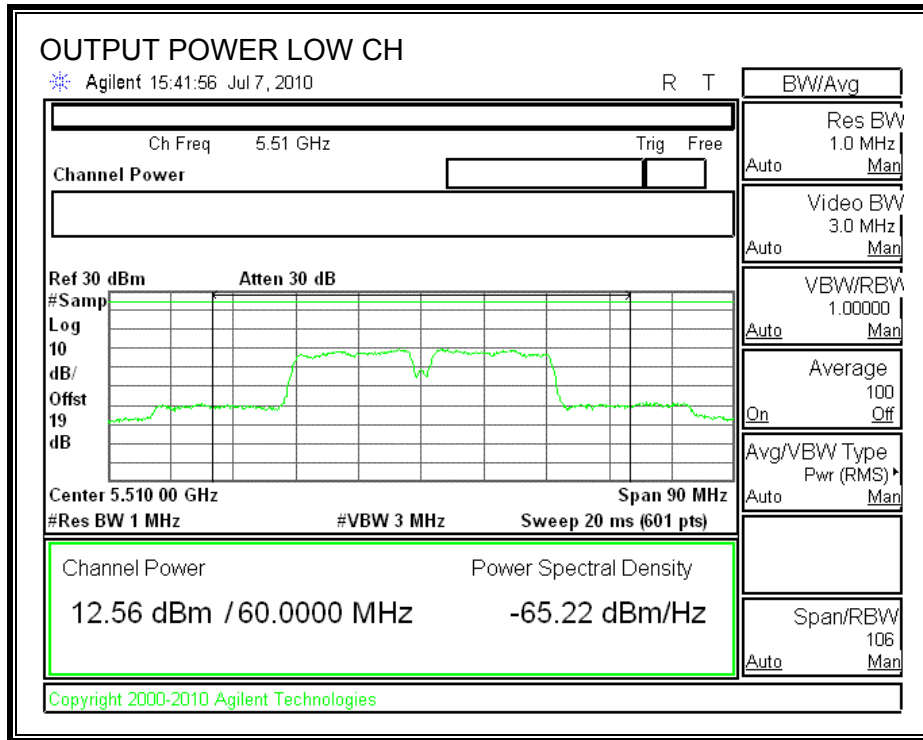

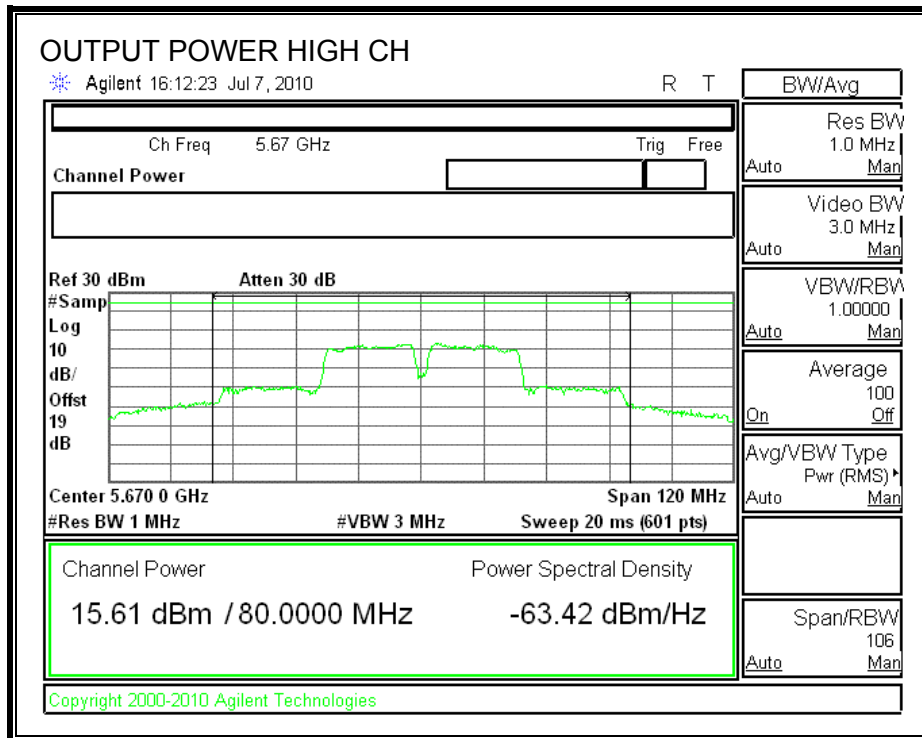

**CHAIN 1 OUTPUT POWER**

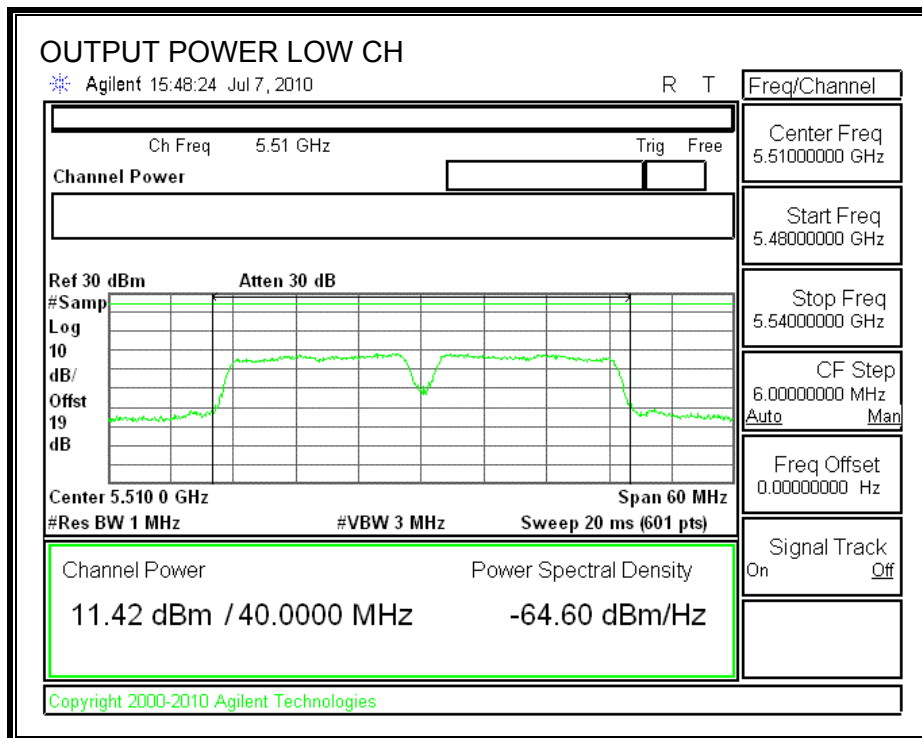

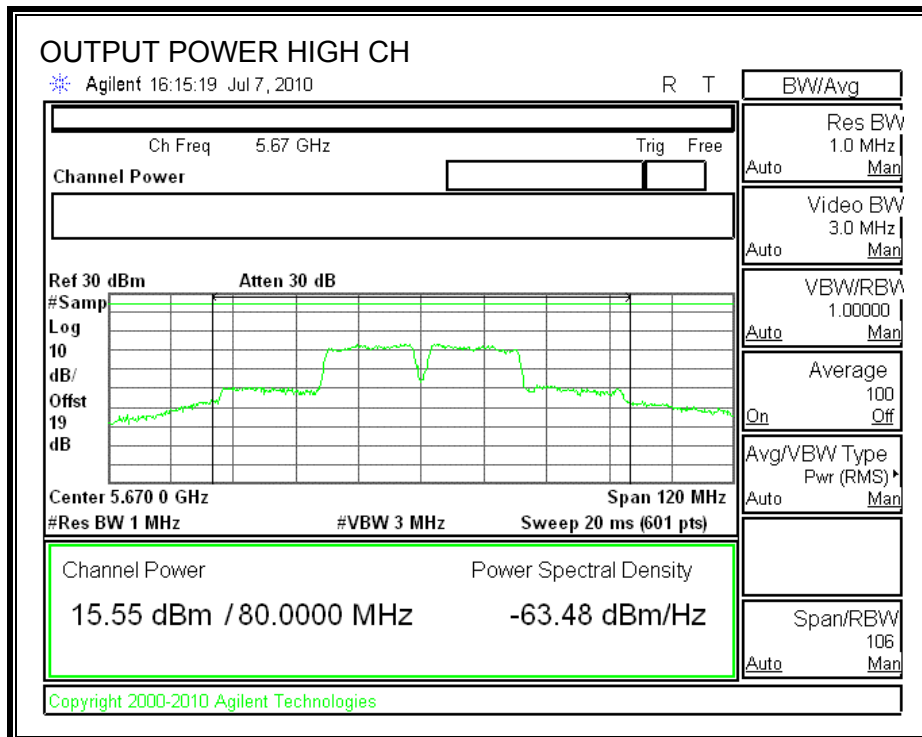
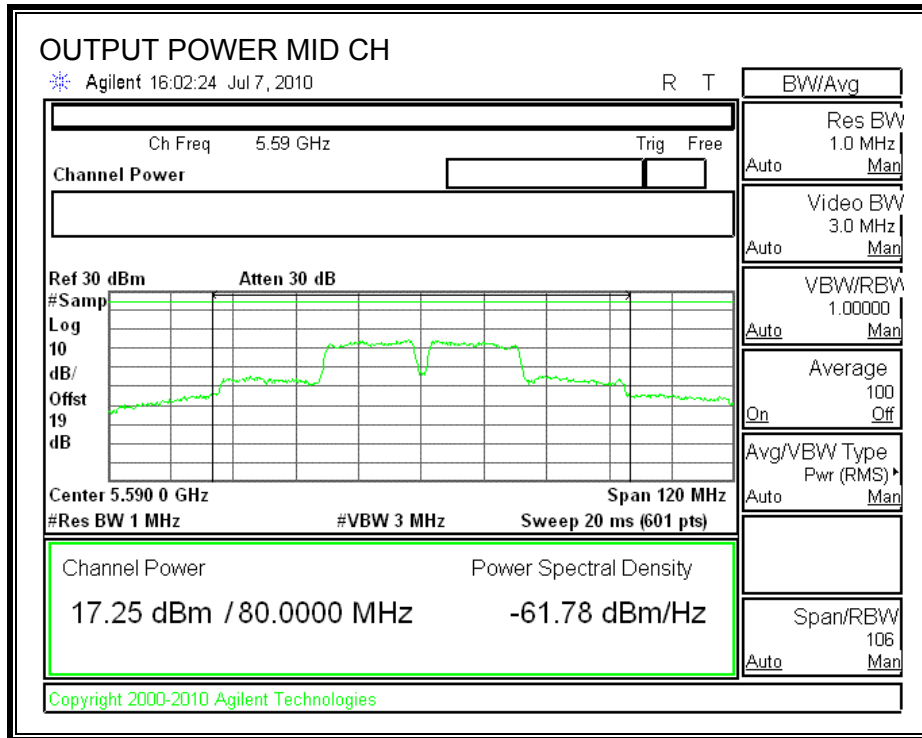

### 7.12.3. PEAK POWER SPECTRAL DENSITY

#### LIMITS

FCC §15.407 (a) (2)

IC RSS-210 A9.2 (2)

For the 5.47-5.725 GHz band, the peak power spectral density shall not exceed 11 dBm in any 1 MHz band. If transmitting antennas of directional gain greater than 6 dBi are used, both the peak transmit power and the peak power spectral density shall be reduced by the amount in dB that the directional gain of the antenna exceeds 6 dBi.

The composite antenna gain equal to 9.22 dBi, therefore the limit is 7.78 dBm.

#### TEST PROCEDURE

The test is performed in accordance with FCC Public Notice: APPENDIX A Guidelines for Assessing Unlicensed National Information Infrastructure (U-NII) Devices – Part 15, Subpart E, August 2002. PPSD method #2 was used.

#### RESULTS

Channel	Frequency (MHz)	PPSD With Combiner (dBm)	Limit (dBm)	Margin (dB)
Low	5510	2.21	7.78	-5.57
Middle	5590	7.19	7.78	-0.59
High	5670	6.54	7.78	-1.24

**POWER SPECTRAL DENSITY WITH COMBINER**

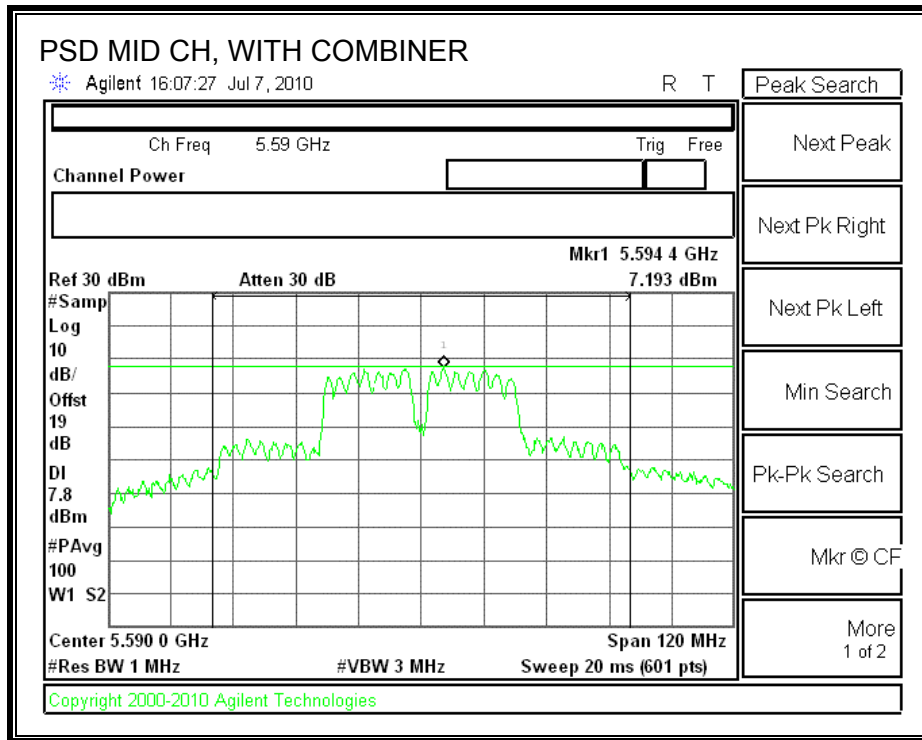
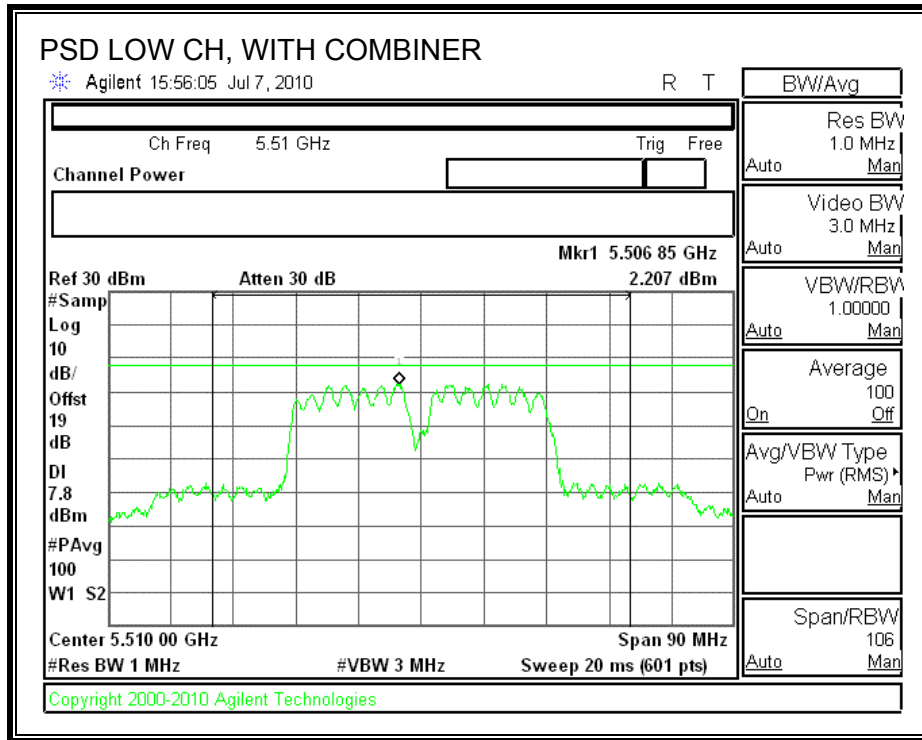



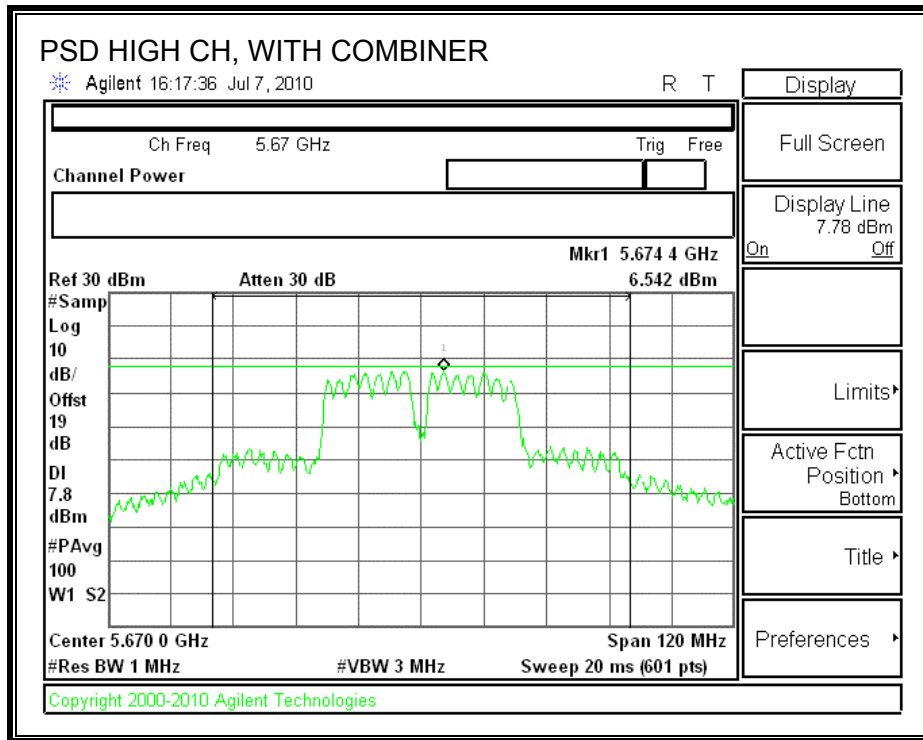

### 7.12.4. PEAK EXCURSION

#### LIMITS

FCC §15.407 (a) (6)

The ratio of the peak excursion of the modulation envelope (measured using a peak hold function) to the peak transmit power (measured as specified above) shall not exceed 13 dB across any 1 MHz bandwidth or the emission bandwidth whichever is less.

#### TEST PROCEDURE

The transmitter outputs are connected to the spectrum analyzer via a combiner.

The test is performed in accordance with FCC Public Notice: APPENDIX A Guidelines for Assessing Unlicensed National Information Infrastructure (U-NII) Devices – Part 15, Subpart E, August 2002.

Since Method # 1 was used for peak power measurements, Method # 1 settings are used for the second PPSD trace.

#### RESULTS

##### CHAIN 1

Channel	Frequency (MHz)	Peak Excursion (dB)	Limit (dB)	Margin (dB)
Low	5510	8.66	13	-4.34
Middle	5590	8.16	13	-4.84
High	5670	8.35	13	-4.65

##### CHAIN 2

Channel	Frequency (MHz)	Peak Excursion (dB)	Limit (dB)	Margin (dB)
Low	5510	9.28	13	-3.72
Middle	5590	9.10	13	-3.90
High	5670	9.17	13	-3.83

**CHAIN 0**

**PEAK EXCURSION**

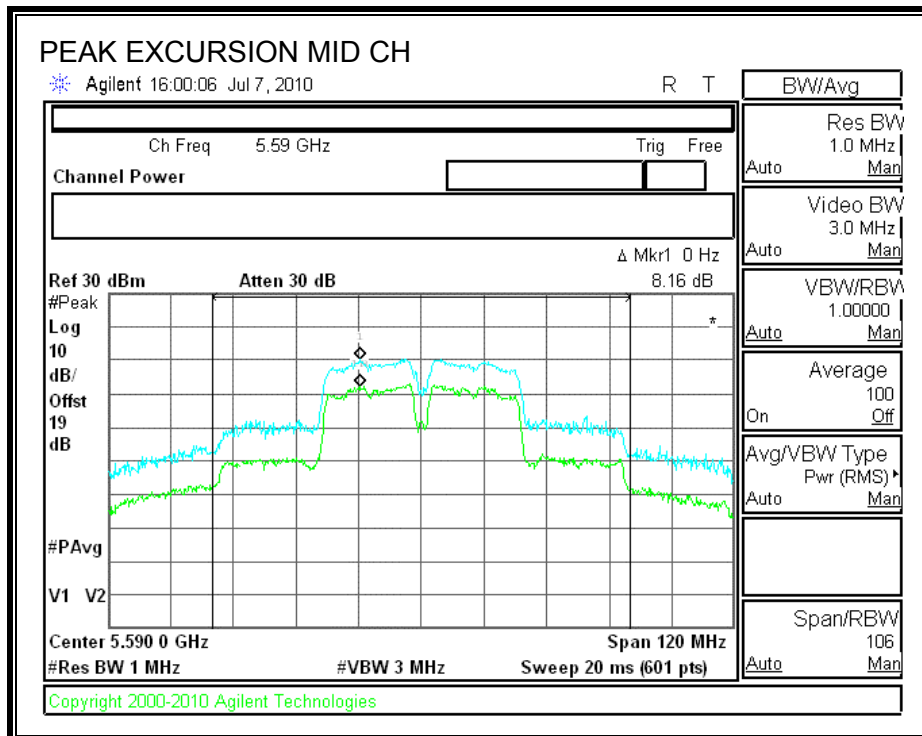
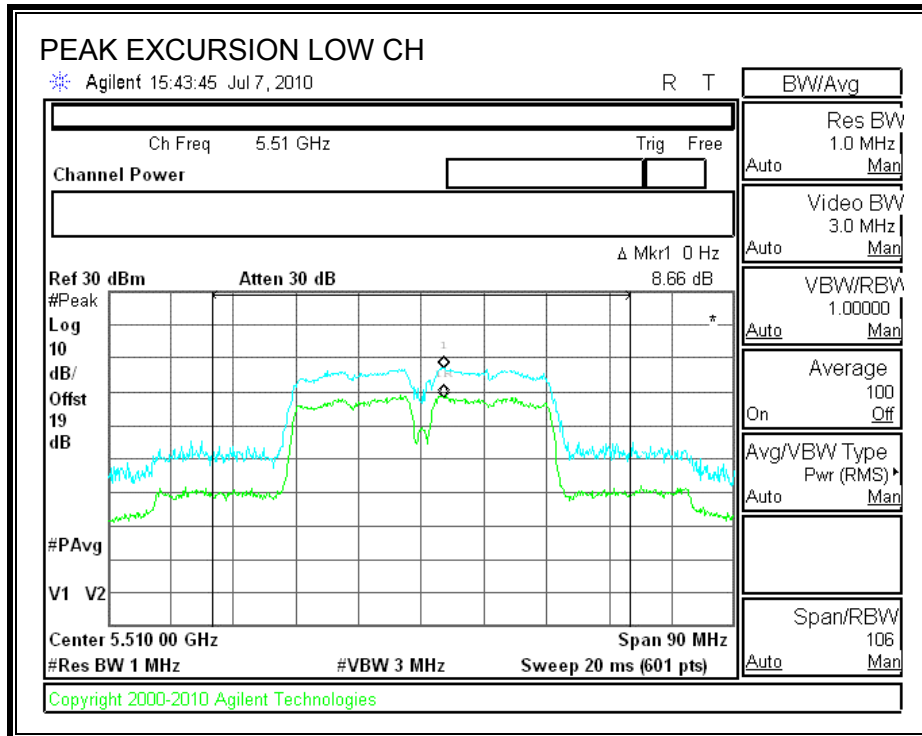

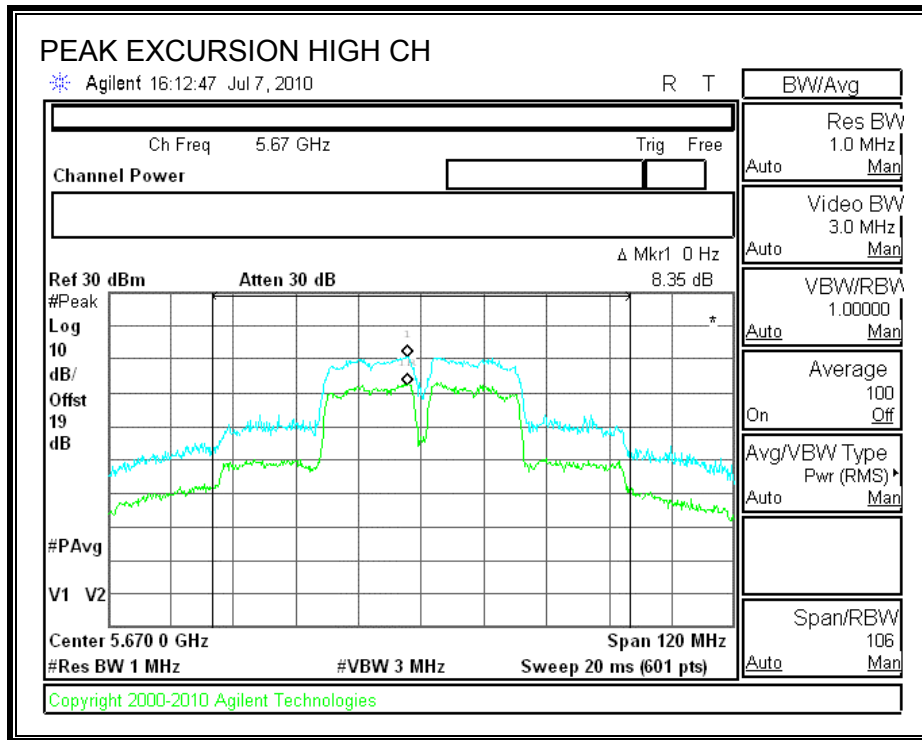

**CHAIN 1**

**PEAK EXCURSION**

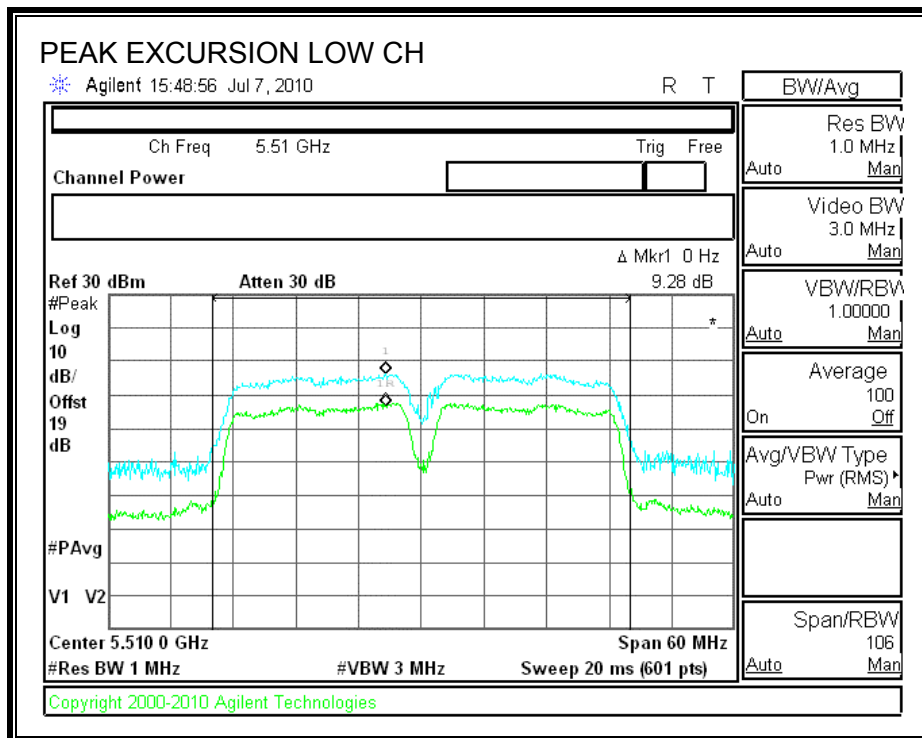

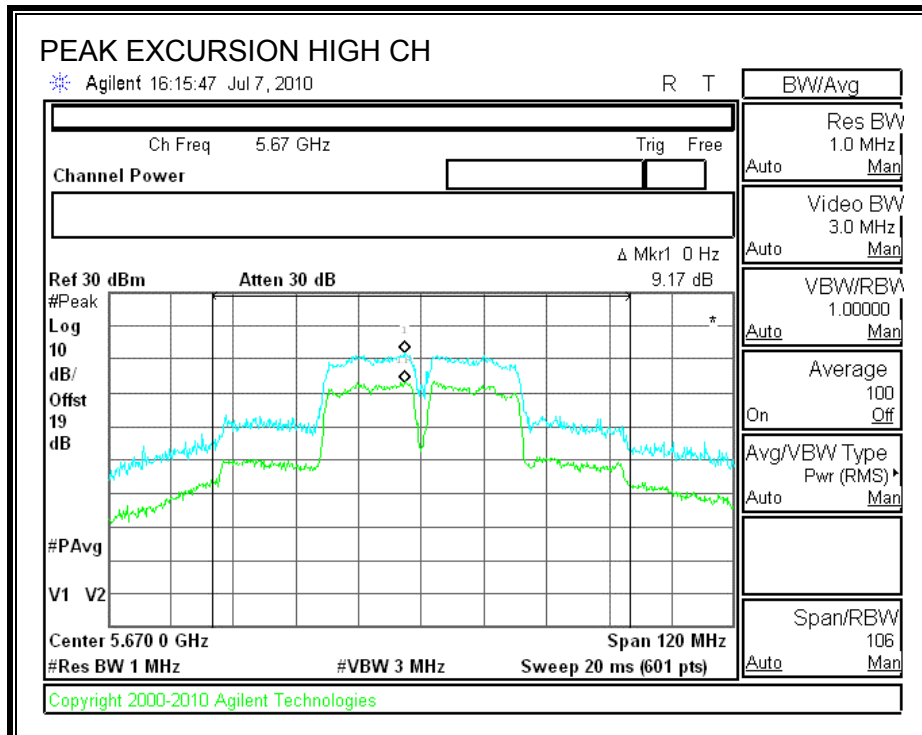
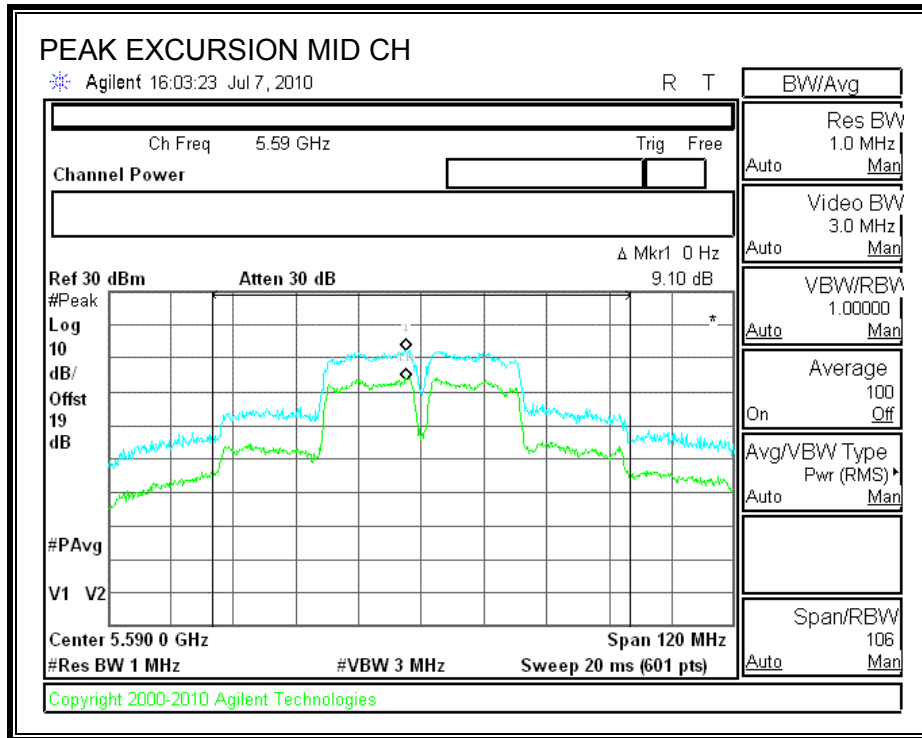

## 7.12.5. CONDUCTED SPURIOUS EMISSIONS

### LIMITS

FCC §15.407 (b) (3)

IC RSS-210 A9.3 (3)

For transmitters operating in the 5.47-5.725 GHz band: all emissions outside of the 5.47-5.725 GHz band shall not exceed an EIRP of -27 dBm / MHz.

### TEST PROCEDURE

Conducted RF measurements of the transmitter output are made to confirm that the EUT antenna port conducted emissions meet the specified limit and to identify any spurious signals that require further investigation or measurements on the radiated emissions site.

The transmitter output is connected to the spectrum analyzer. The resolution bandwidth is set to 1 MHz. The video bandwidth is set to 1MHz. Peak detection measurements are compared to EIRP limit, adjusted for the maximum antenna gain.

Measurements are made over the 30 MHz to 40 GHz range with the transmitter set to the lowest, middle, and highest channels.

**SPURIOUS EMISSIONS WITH COMBINER**

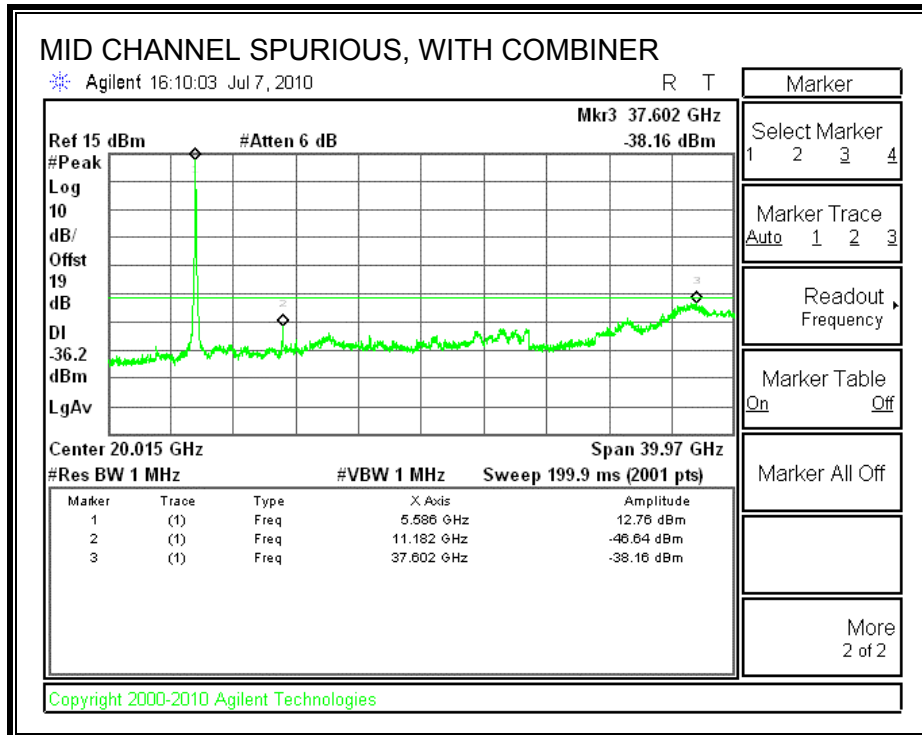
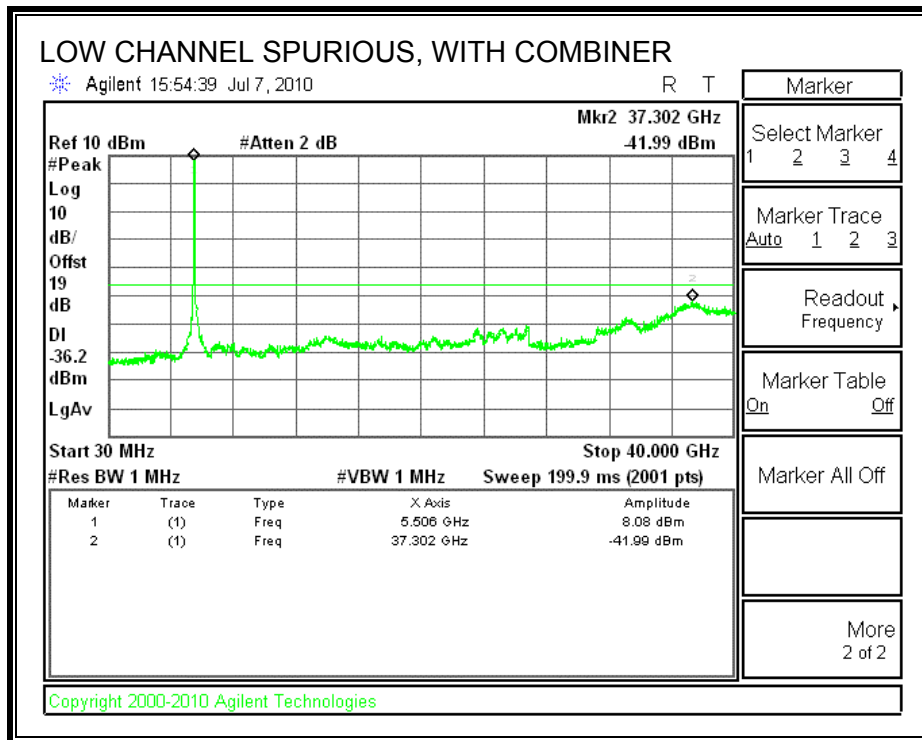

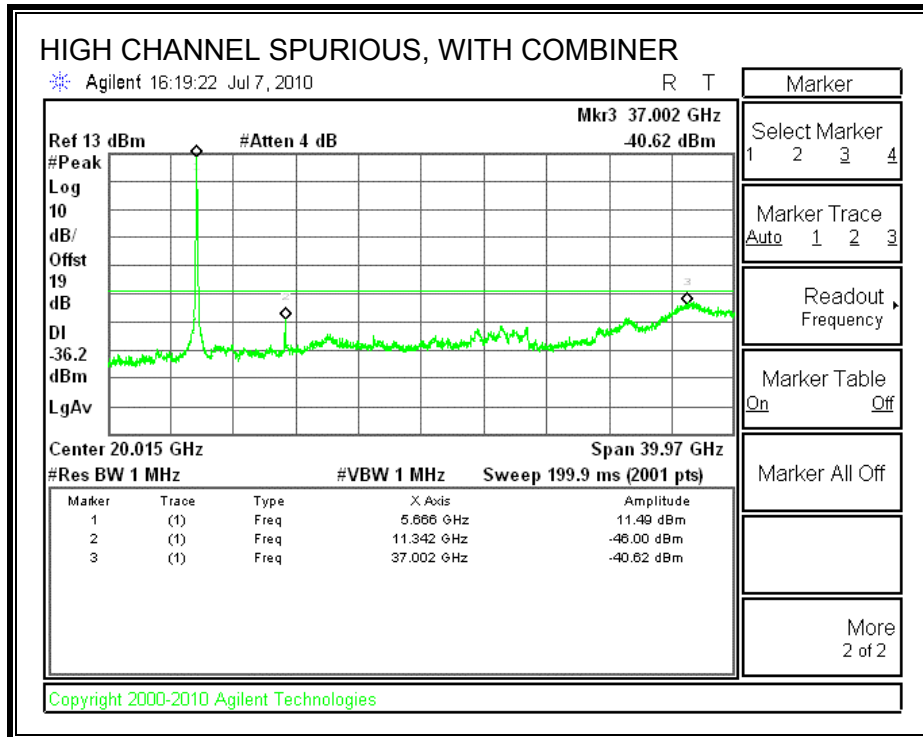



### 7.12.6. CO-LOCATED CONDUCTED SPURIOUS EMISSIONS

#### SPURIOUS EMISSIONS WITH COMBINER

\_WLAN 5.2GHz BAND: HT40 MCS8 SDM\_CHANNEL 38, 5190MHz

\_BLUETOOTH 8PSK\_CHANNEL 0, 2402MHz

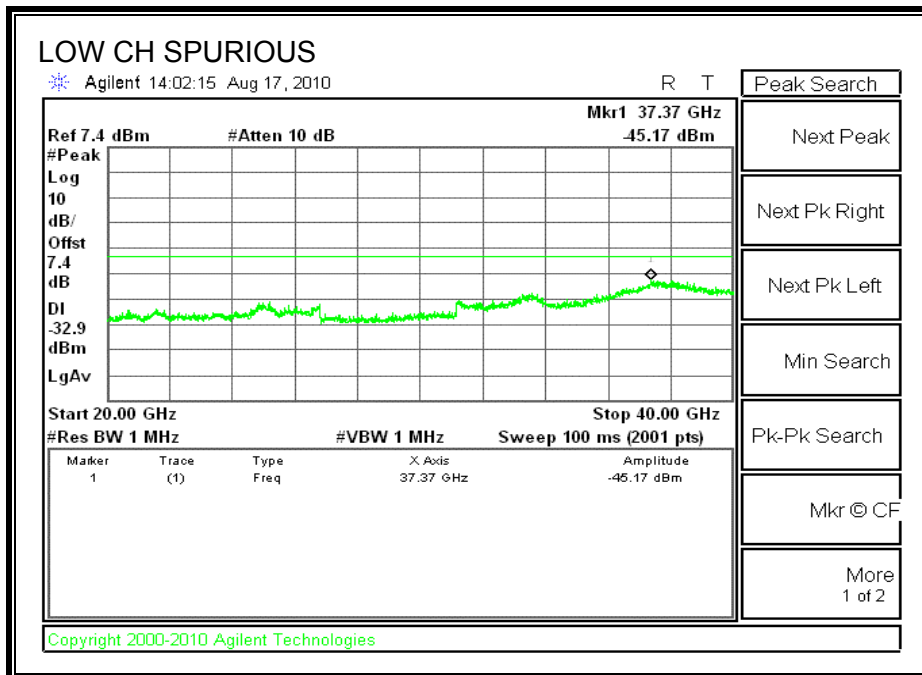
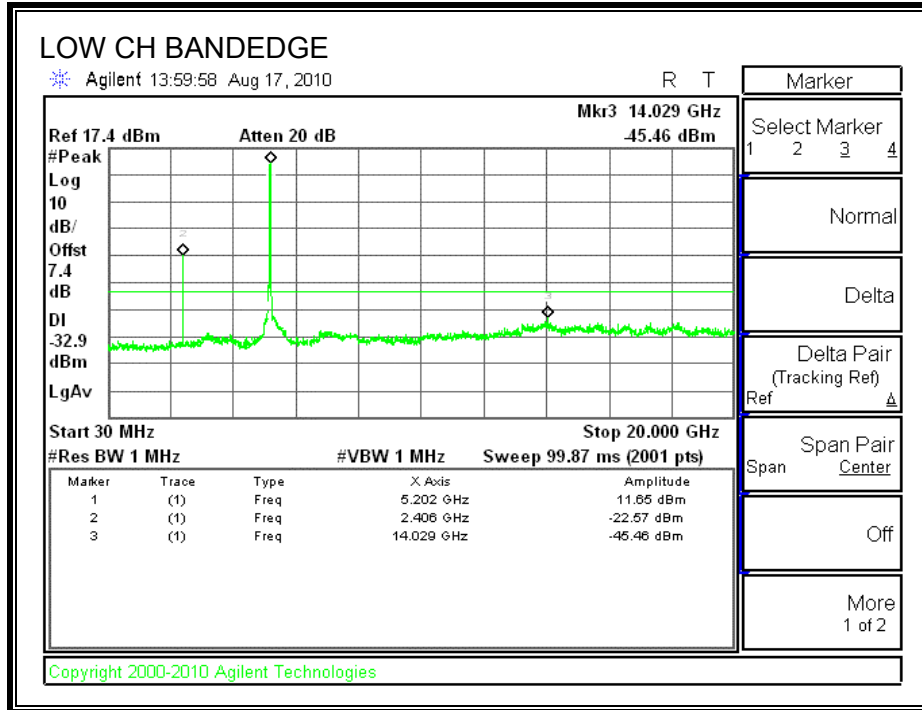

**SPURIOUS EMISSIONS WITH COMBINER**

\_WLAN 5.3GHz BAND: HT40 MCS0 SISO\_CHANNEL 62, 5310MHz  
\_BLUETOOTH 8PSK\_CHANNEL 79, 2480MHz

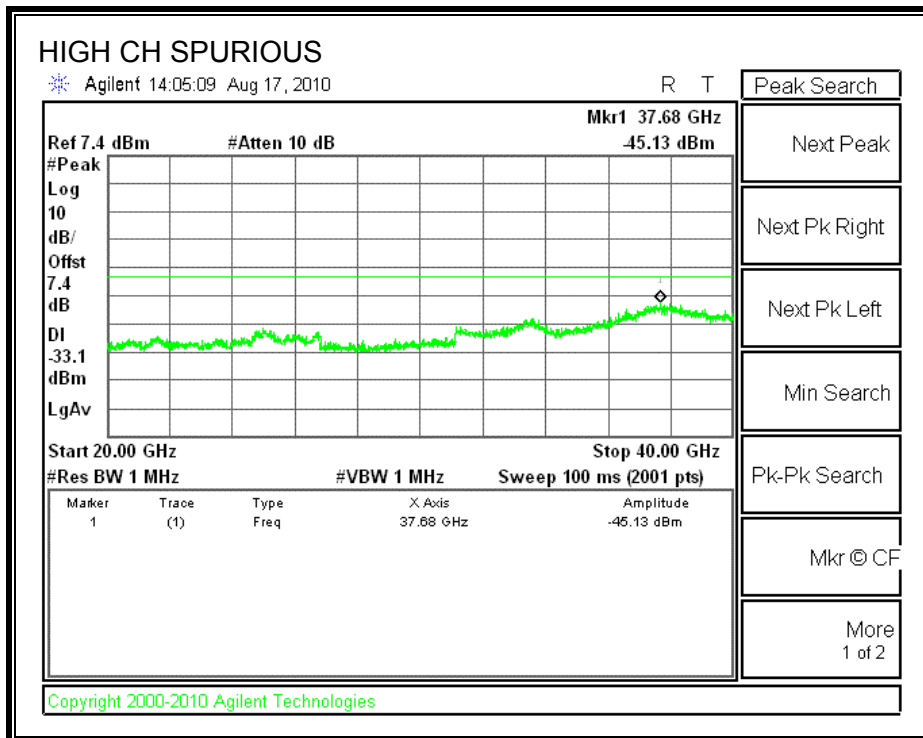
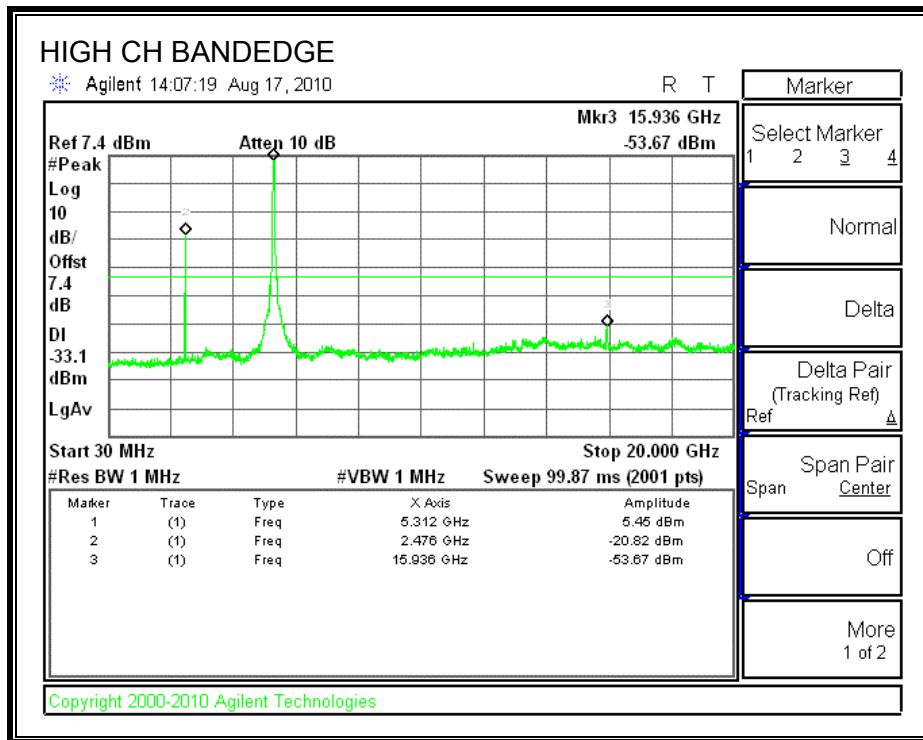

**SPURIOUS EMISSIONS WITH COMBINER**

\_WLAN 5.6GHz BAND: HT20 MCS0 CDD\_CHANNEL 140, 5700MHz  
\_BLUETOOTH 8PSK\_CHANNEL 79, 2480MHz

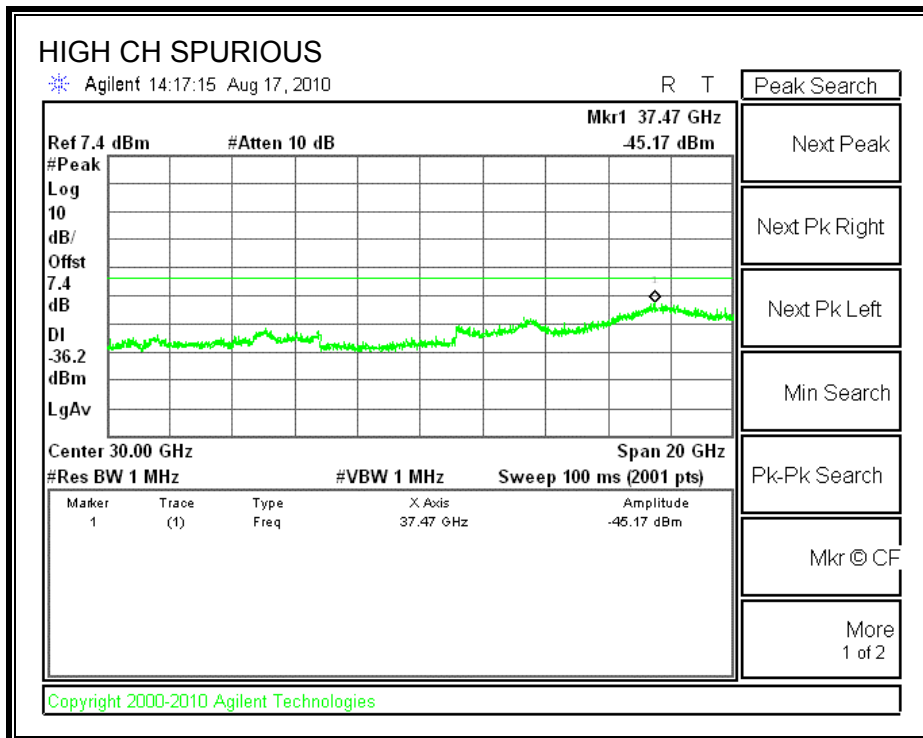
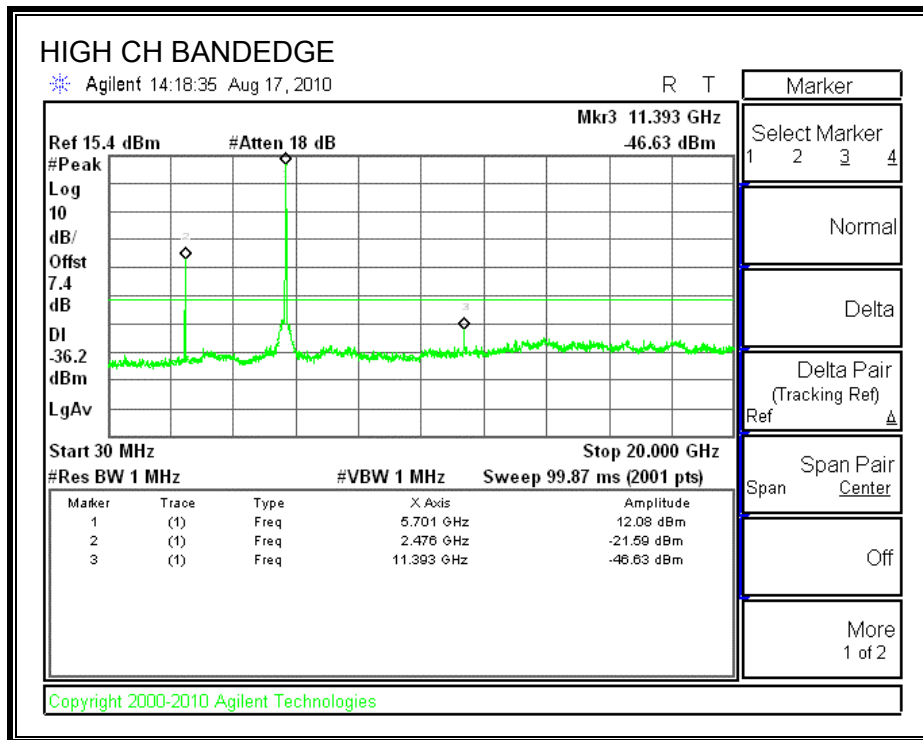

## 8. RADIATED TEST RESULTS

### 8.1. LIMITS AND PROCEDURE

#### LIMITS

FCC §15.205 and §15.209

IC RSS-210 Clause 2.6 (Transmitter)

IC RSS-GEN Clause 6 (Receiver)

Frequency Range (MHz)	Field Strength Limit (uV/m) at 3 m	Field Strength Limit (dBuV/m) at 3 m
30 - 88	100	40
88 - 216	150	43.5
216 - 960	200	46
Above 960	500	54

#### TEST PROCEDURE

The EUT is placed on a non-conducting table 80 cm above the ground plane. The antenna to EUT distance is 3 meters. The EUT is configured in accordance with ANSI C63.4. The EUT is set to transmit in a continuous mode.

For measurements below 1 GHz the resolution bandwidth is set to 100 kHz for peak detection measurements or 120 kHz for quasi-peak detection measurements. Peak detection is used unless otherwise noted as quasi-peak.

For measurements above 1 GHz the resolution bandwidth is set to 1 MHz, and then the video bandwidth is set to 1 MHz for peak measurements and 10 Hz for average measurements.

The spectrum from 30 MHz to 40 GHz is investigated with the transmitter set to the lowest, middle, and highest channels in each applicable band.

The frequency range of interest is monitored at a fixed antenna height and EUT azimuth. The EUT is rotated through 360 degrees to maximize emissions received. The antenna is scanned from 1 to 4 meters above the ground plane to further maximize the emission. Measurements are made with the antenna polarized in both the vertical and the horizontal positions.

## 8.2. TRANSMITTER ABOVE 1 GHz

### 8.2.1. 802.11a MODE IN THE LOWER 5.2 GHz BAND

#### RESTRICTED BANDEDGE (LOW CHANNEL, HORIZONTAL)

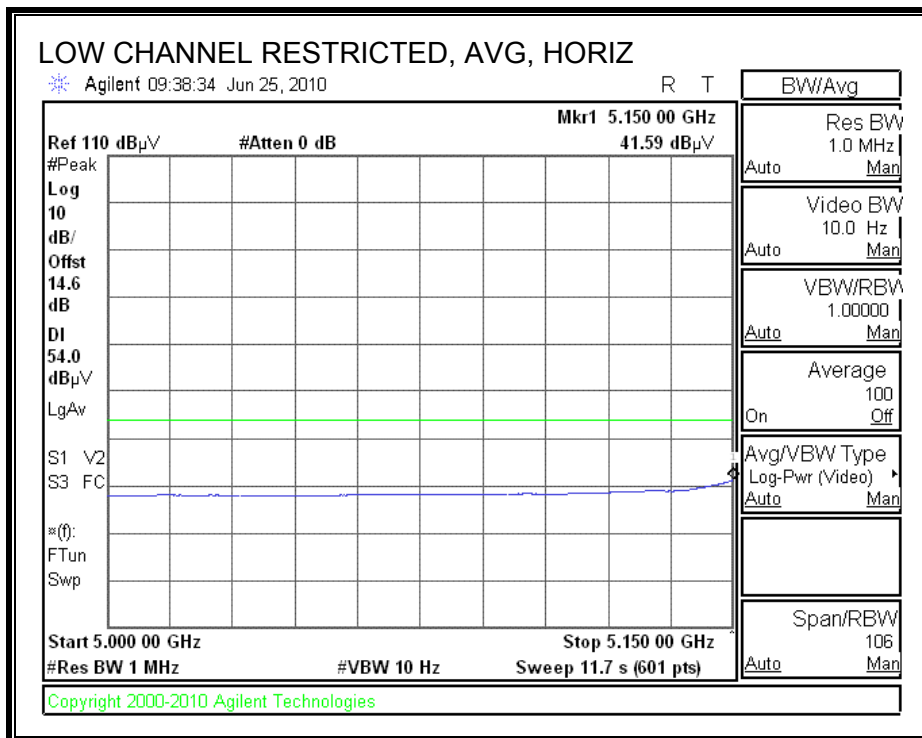
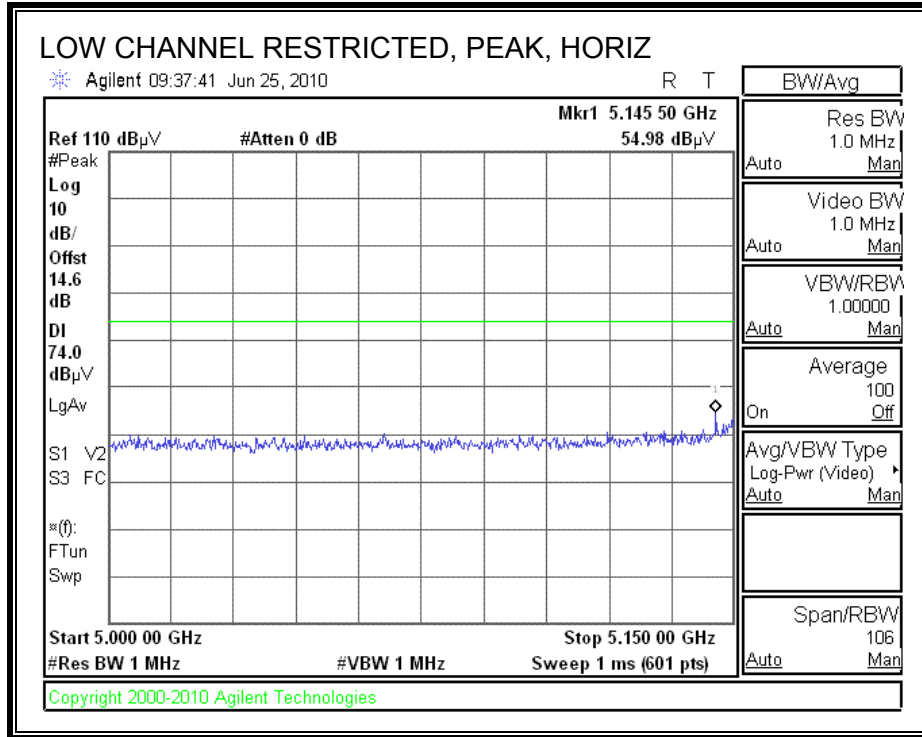

**RESTRICTED BANDEDGE (LOW CHANNEL, VERTICAL)**

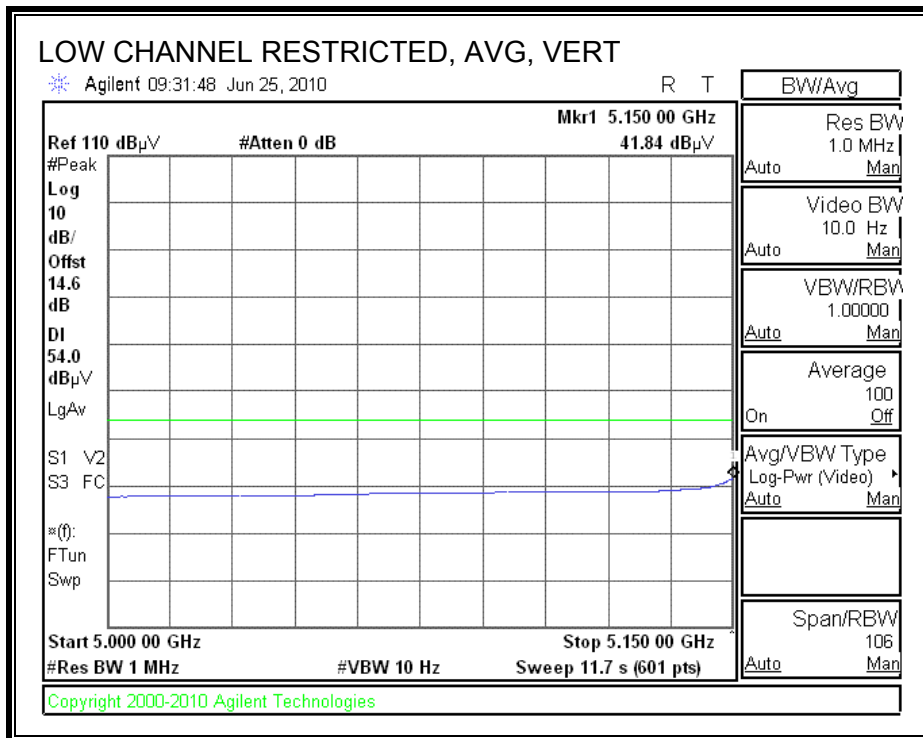
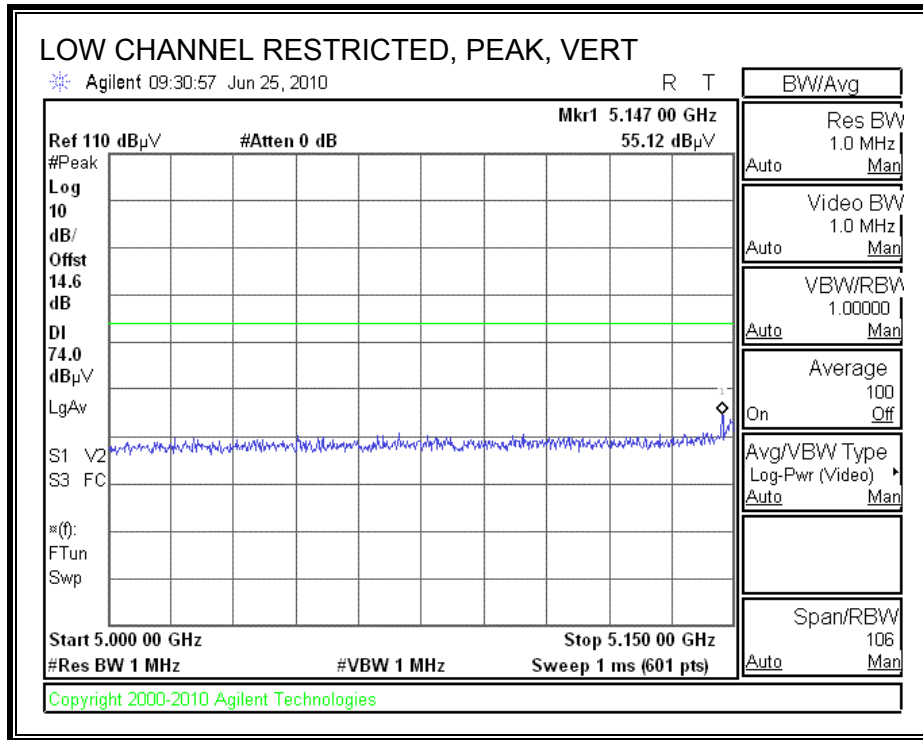

**HARMONICS AND SPURIOUS EMISSIONS**

High Frequency Measurement													
Compliance Certification Services, Fremont 5m Chamber													
Test Engr:		Chin Pang											
Date:		06/29/10											
Project #:		10U13263											
Company:		Broadcom											
EUT Description:		802.11abgn Wlan + bluetooth PCI-E mini card											
EUT M/N:		BCM943224PCIEBT2											
Test Target:		FCC 15.407											
Mode Oper:		TX, 5.2GHz Legacy											
f	Measurement Frequency		Amp	Preamp Gain		Average Field Strength Limit							
Dist	Distance to Antenna		D Corr	Distance Correct to 3 meters		Peak Field Strength Limit							
Read	Analyzer Reading		Avg	Average Field Strength @ 3 m		Margin vs. Average Limit							
AF	Antenna Factor		Peak	Calculated Peak Field Strength		Margin vs. Peak Limit							
CL	Cable Loss		HPF	High Pass Filter									
f	Dist	Read	AF	CL	Amp	D Corr	Filtr	Corr.	Limit	Margin	Ant. Pol	Det.	Notes
GHz	(m)	dBuV	dB/m	dB	dB	dB	dB	dBuV/m	dBuV/m	dB	V/H	P/A/QP	
<b>Low Ch, 5180MHz</b>													
15.540	3.0	39.1	38.5	11.3	-32.2	0.0	0.7	57.5	74.0	-16.5	V	P	
15.540	3.0	26.1	38.5	11.3	-32.2	0.0	0.7	44.5	54.0	-9.5	V	A	
15.540	3.0	38.7	38.5	11.3	-32.2	0.0	0.7	57.1	74.0	-16.9	H	P	
15.540	3.0	22.7	38.5	11.3	-32.2	0.0	0.7	41.1	54.0	-12.9	H	A	
<b>Mid Ch, 5200MHz</b>													
15.600	3.0	42.4	38.3	11.4	-32.2	0.0	0.7	60.7	74.0	-13.3	H	P	
15.600	3.0	24.2	38.3	11.4	-32.2	0.0	0.7	42.4	54.0	-11.6	H	A	
15.600	3.0	39.9	38.3	11.4	-32.2	0.0	0.7	58.1	74.0	-15.9	V	P	
15.600	3.0	24.6	38.3	11.4	-32.2	0.0	0.7	42.8	54.0	-11.2	V	A	
<b>High Ch, 5240MHz</b>													
15.720	3.0	41.2	38.0	11.4	-32.2	0.0	0.7	59.2	74.0	-14.8	V	P	
15.720	3.0	24.8	38.0	11.4	-32.2	0.0	0.7	42.8	54.0	-11.2	V	A	
15.720	3.0	42.1	38.0	11.4	-32.2	0.0	0.7	60.1	74.0	-13.9	H	P	
15.720	3.0	23.9	38.0	11.4	-32.2	0.0	0.7	41.8	54.0	-12.2	H	A	
Rev. 4.1.2.7													
Note: No other emissions were detected above the system noise floor.													

### 8.2.2. 802.11n HT20 MODE IN THE LOWER 5.2 GHz BAND

#### HT20 MCS8 SDM – Non-Coherent

#### RESTRICTED BANDEDGE (LOW CHANNEL, HORIZONTAL)

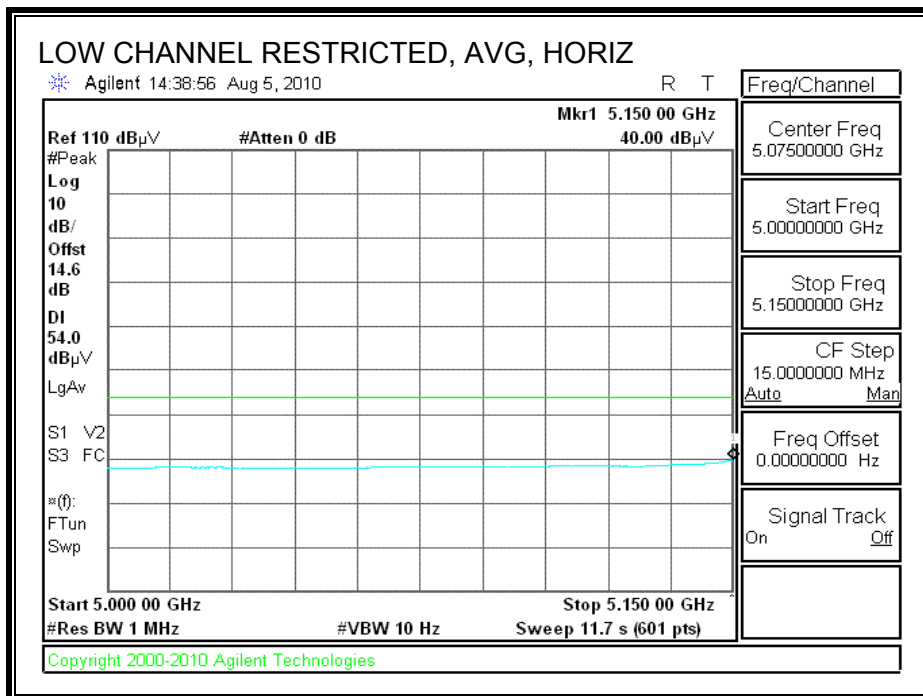
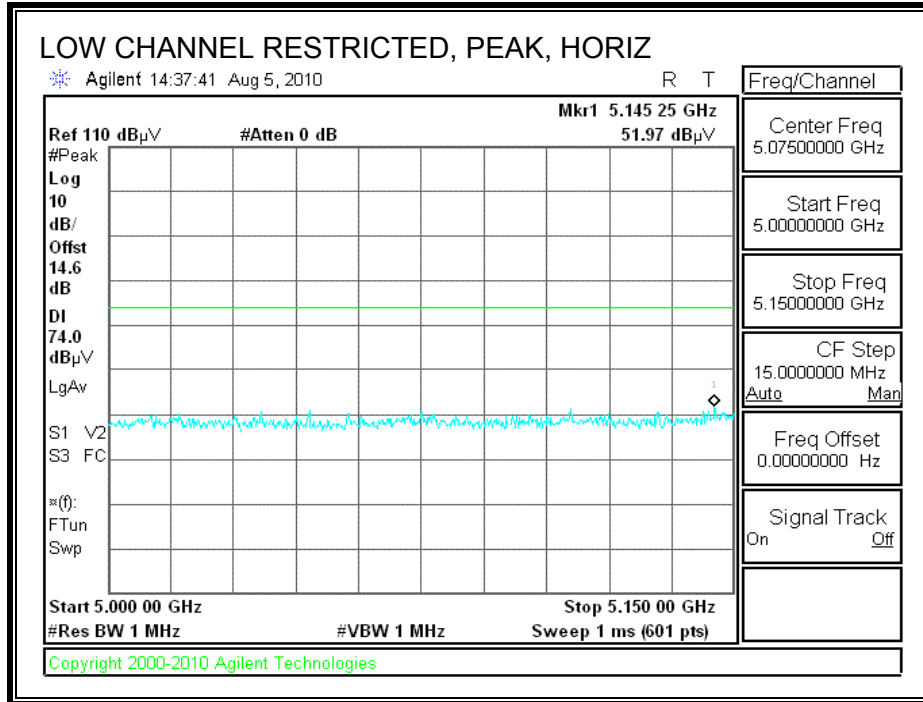



**RESTRICTED BANDEDGE (LOW CHANNEL, VERTICAL)**

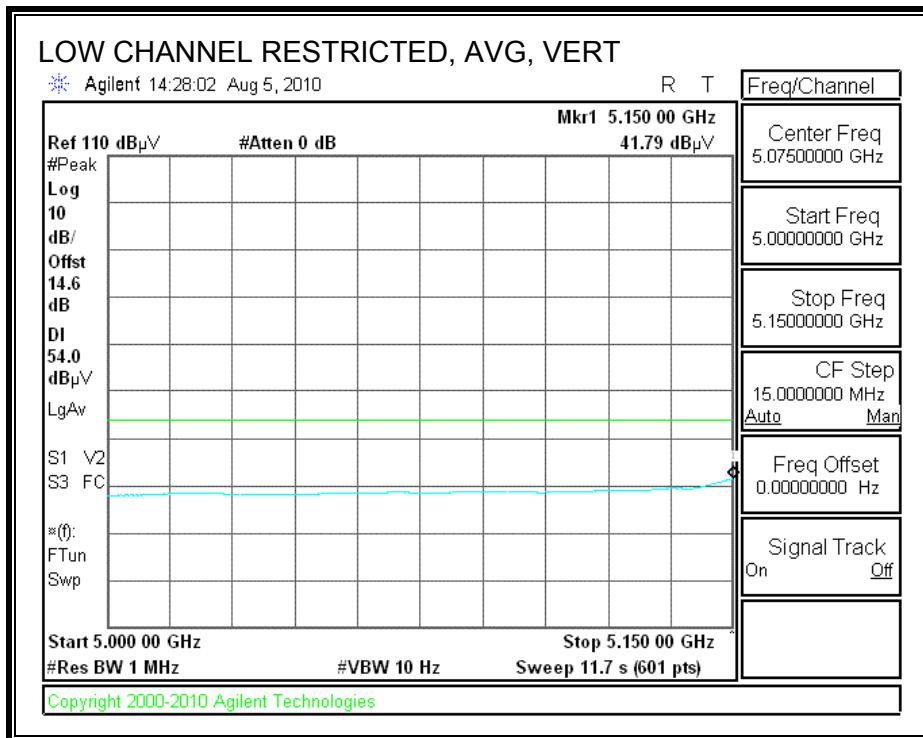
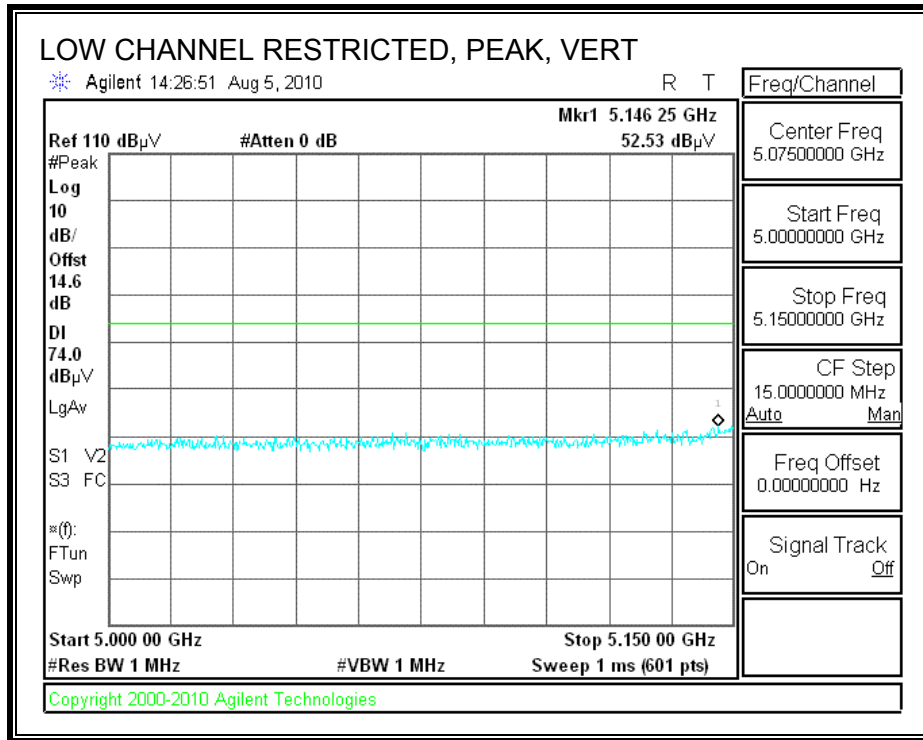

**HARMONICS AND SPURIOUS EMISSIONS**

High Frequency Measurement													
Compliance Certification Services, Fremont 5m Chamber													
Test Engr:		Vien Tran											
Date:		08/12/10											
Project #:		10U13263											
Company:		Broadcom											
EUT Description:		802.11abgn Wlan + bluetooth PCI-E mini card											
EUT M/N:		BCM943224PCIEBT2											
Test Target:		FCC 15.407											
Mode Oper:		HT20 MCS8 SDM Non-coherent											
f	Measurement Frequency		Amp	Preamp Gain		Average Field Strength Limit							
Dist	Distance to Antenna		D Corr	Distance Correct to 3 meters		Peak Field Strength Limit							
Read	Analyzer Reading		Avg	Average Field Strength @ 3 m		Margin vs. Average Limit							
AF	Antenna Factor		Peak	Calculated Peak Field Strength		Margin vs. Peak Limit							
CL	Cable Loss		HPF	High Pass Filter									
f	Dist	Read	AF	CL	Amp	D Corr	Fltr	Corr.	Limit	Margin	Ant. Pol	Det.	Notes
GHz	(m)	dBuV	dB/m	dB	dB	dB	dB	dBuV/m	dBuV/m	dB	V/H	P/A/QP	
<b>LOW CHANNEL, 5180MHz</b>													
15.540	3.0	33.1	38.5	11.3	-32.2	0.0	0.0	50.7	74.0	-23.3	H	P	
15.540	3.0	20.3	38.5	11.3	-32.2	0.0	0.0	37.9	54.0	-16.1	H	A	
15.540	3.0	32.9	38.5	11.3	-32.2	0.0	0.0	50.5	74.0	-23.5	V	P	
15.540	3.0	20.2	38.5	11.3	-32.2	0.0	0.0	37.9	54.0	-16.1	V	A	
<b>HIGH CHANNEL, 5240MHz</b>													
15.720	3.0	32.9	38.0	11.4	-32.2	0.0	0.0	50.1	74.0	-23.9	H	P	
15.720	3.0	20.1	38.0	11.4	-32.2	0.0	0.0	37.4	54.0	-16.6	H	A	
15.720	3.0	32.4	38.0	11.4	-32.2	0.0	0.0	49.7	74.0	-24.3	V	P	
15.720	3.0	20.2	38.0	11.4	-32.2	0.0	0.0	37.5	54.0	-16.5	V	A	
Rev. 4.1.2.7													
Note: No other emissions were detected above the system noise floor.													

**HT20 MCS12 SDM – Non-Coherent**

**RESTRICTED BANDEDGE (LOW CHANNEL, HORIZONTAL)**

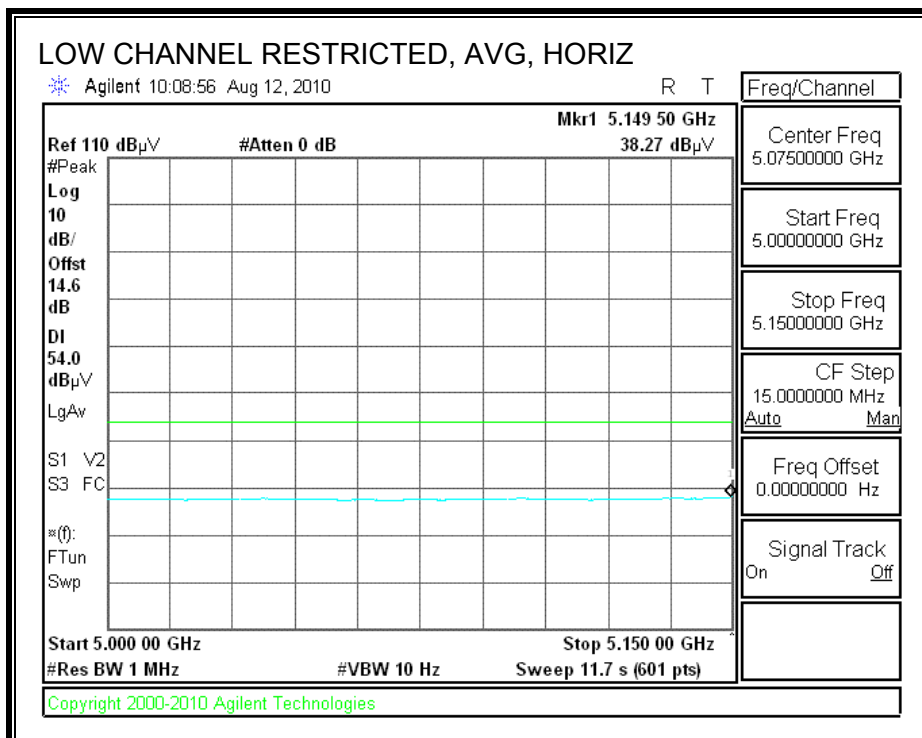
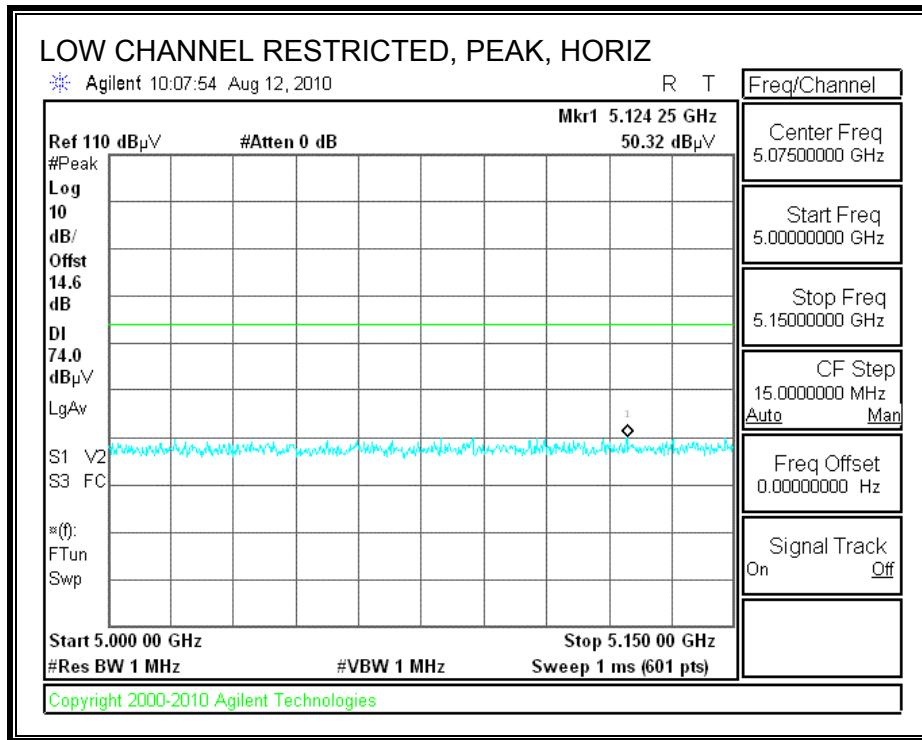

**RESTRICTED BANDEDGE (LOW CHANNEL, VERTICAL)**

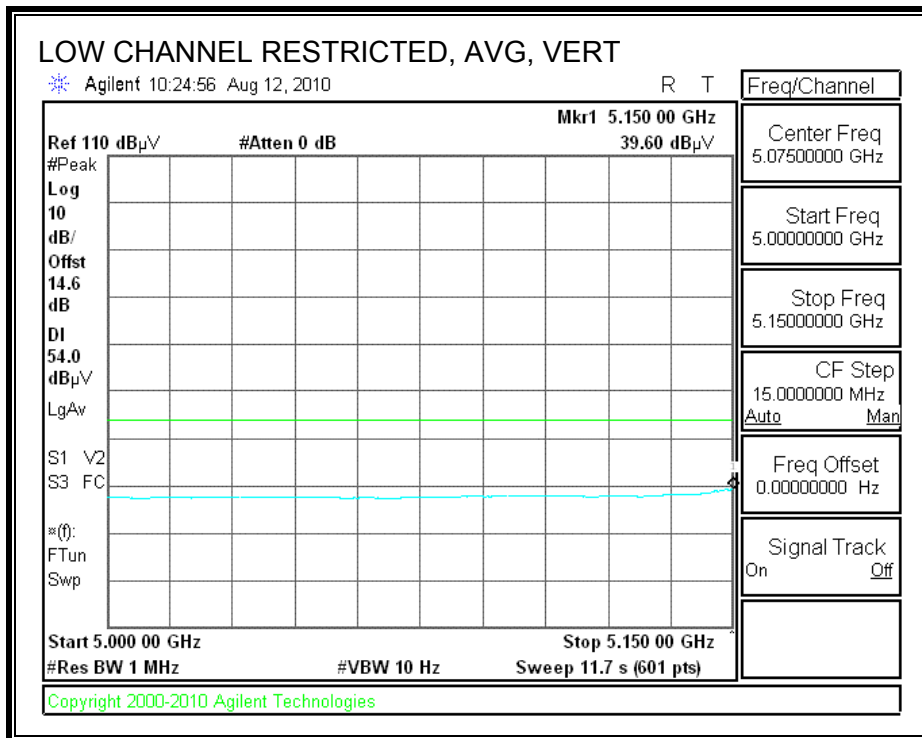
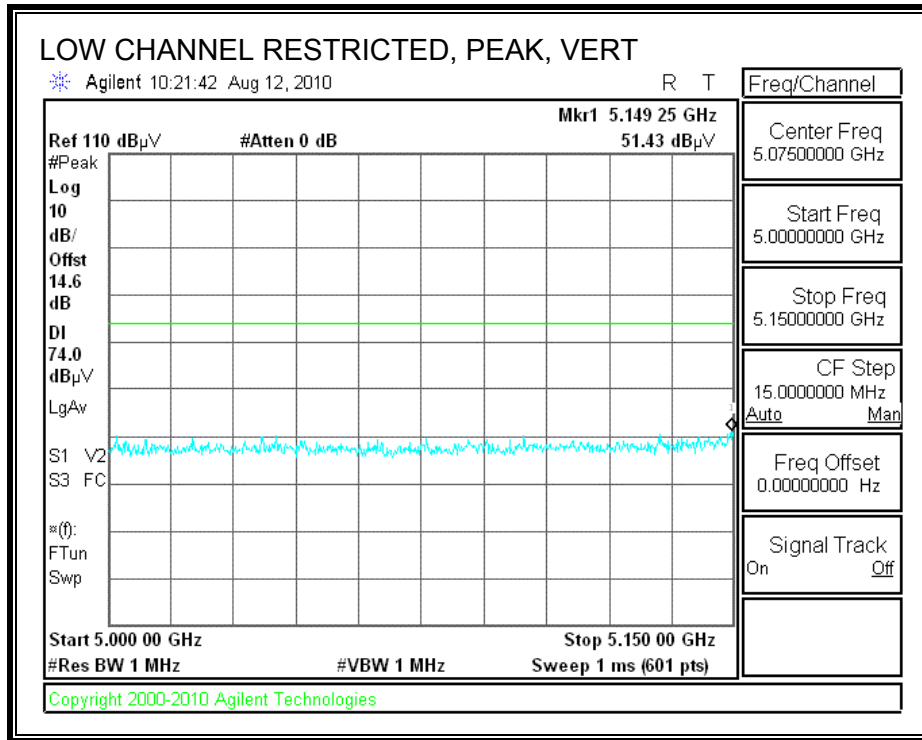

**HARMONICS AND SPURIOUS EMISSIONS**

High Frequency Measurement													
Compliance Certification Services, Fremont 5m Chamber													
Test Engr:		Vien Tran											
Date:		08/12/10											
Project #:		10U13263											
Company:		Broadcom											
EUT Description:		802.11abgn Wlan + bluetooth PCI-E mini card											
EUT M/N:		BCM943224PCIEBT2											
Test Target:		FCC 15.407											
Mode Oper:		11n HT20 MCS12 SDM_Non-Coherent											
f	Measurement Frequency			Amp	Preamp Gain			Average Field Strength Limit					
Dist	Distance to Antenna			D Corr	Distance Correct to 3 meters			Peak Field Strength Limit					
Read	Analyzer Reading			Avg	Average Field Strength @ 3 m			Margin vs. Average Limit					
AF	Antenna Factor			Peak	Calculated Peak Field Strength			Margin vs. Peak Limit					
CL	Cable Loss			HPF	High Pass Filter								
f	Dist	Read	AF	CL	Amp	D Corr	Fltr	Corr.	Limit	Margin	Ant. Pol	Det.	Notes
GHz	(m)	dBuV	dB/m	dB	dB	dB	dB	dBuV/m	dBuV/m	dB	V/H	P/A/QP	
<b>LOW CHANNEL, 5180MHz</b>													
15.540	3.0	33.1	38.5	11.3	-32.2	0.0	0.0	50.7	74.0	-23.3	H	P	
15.540	3.0	20.3	38.5	11.3	-32.2	0.0	0.0	37.9	54.0	-16.1	H	A	
15.540	3.0	32.9	38.5	11.3	-32.2	0.0	0.0	50.5	74.0	-23.5	V	P	
15.540	3.0	20.2	38.5	11.3	-32.2	0.0	0.0	37.9	54.0	-16.1	V	A	
<b>HIGH CHANNEL, 5240MHz</b>													
15.720	3.0	32.9	38.0	11.4	-32.2	0.0	0.0	50.1	74.0	-23.9	H	P	
15.720	3.0	20.1	38.0	11.4	-32.2	0.0	0.0	37.4	54.0	-16.6	H	A	
15.720	3.0	32.4	38.0	11.4	-32.2	0.0	0.0	49.7	74.0	-24.3	V	P	
15.720	3.0	20.2	38.0	11.4	-32.2	0.0	0.0	37.5	54.0	-16.5	V	A	
Rev. 4.1.2.7													
Note: No other emissions were detected above the system noise floor.													

**HT20 MCS15 SDM – Non-Coherent**

**RESTRICTED BANDEDGE (LOW CHANNEL, HORIZONTAL)**

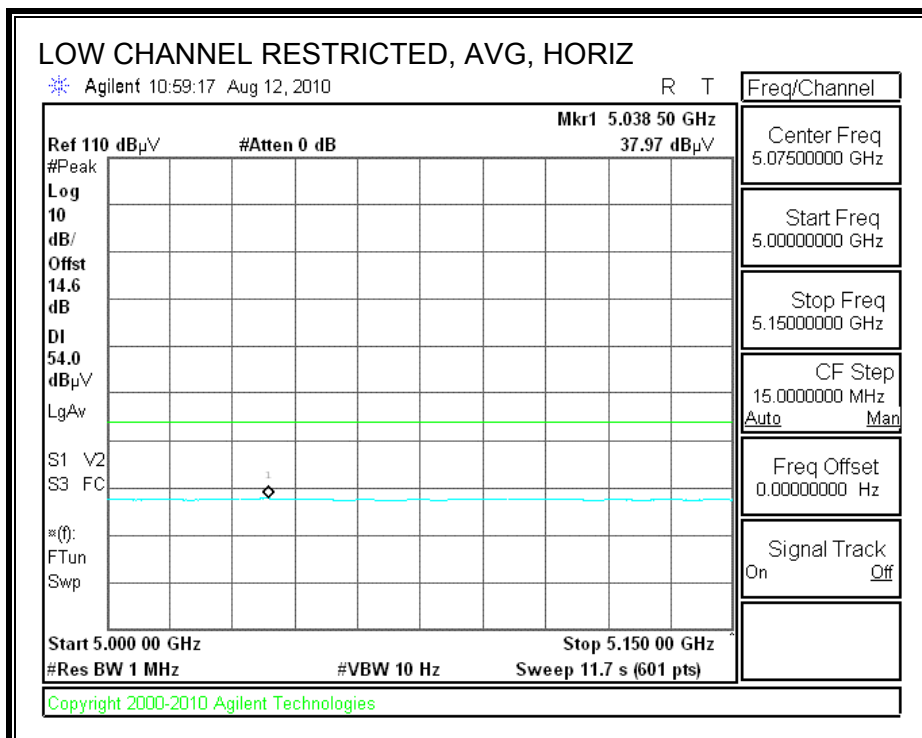
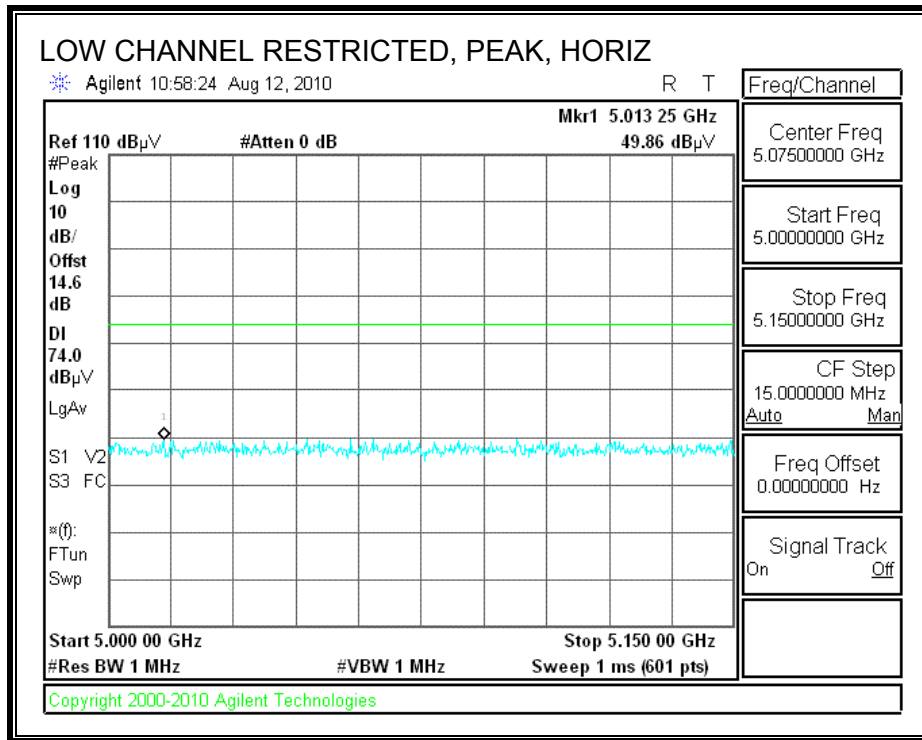

**RESTRICTED BANDEDGE (LOW CHANNEL, VERTICAL)**

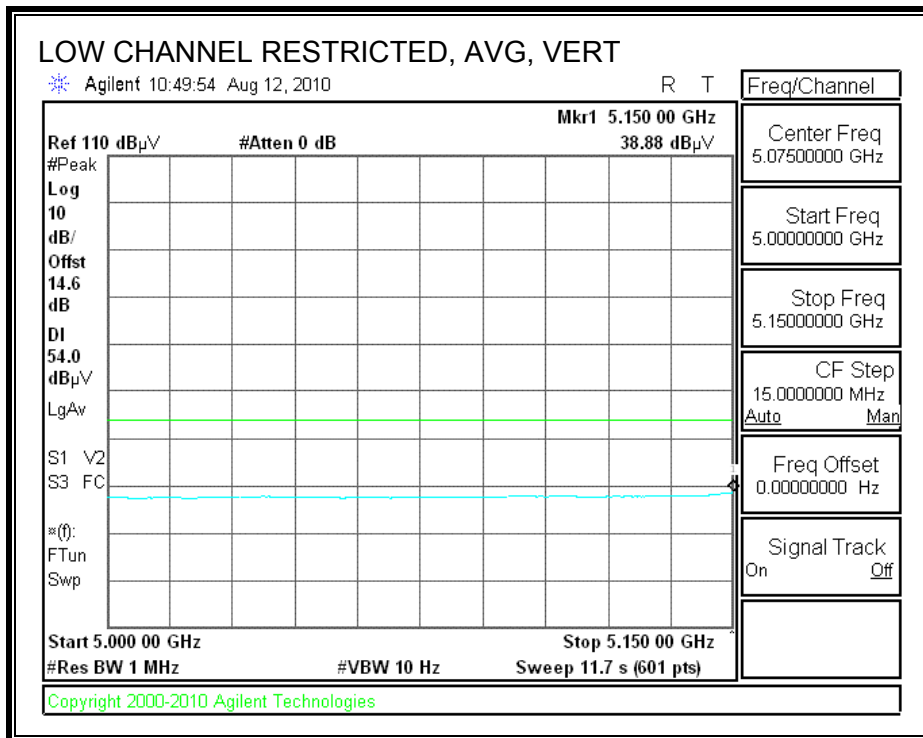
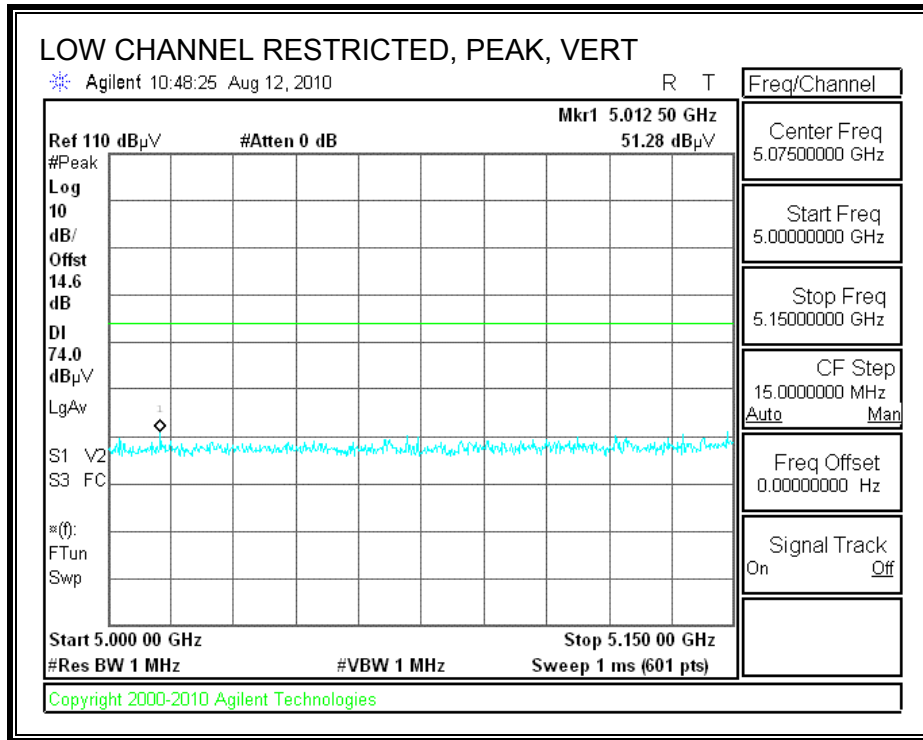

**HARMONICS AND SPURIOUS EMISSIONS**

High Frequency Measurement													
Compliance Certification Services, Fremont 3m Chamber													
Test Engr:		Vien Tran											
Date:		08/12/10											
Project #:		10U13263											
Company:		Broadcom											
EUT Description:		802.11abgn Wlan + bluetooth PCI-E mini card											
EUT M/N:		BCM943224PCIEBT2											
Test Target:		FCC 15.407											
Mode Oper:		HT20 MCS15 SDM Non-coheren											
f	Measurement Frequency		Amp	Preamp Gain		Average Field Strength Limit							
Dist	Distance to Antenna		D Corr	Distance Correct to 3 meters		Peak Field Strength Limit							
Read	Analyzer Reading		Avg	Average Field Strength @ 3 m		Margin vs. Average Limit							
AF	Antenna Factor		Peak	Calculated Peak Field Strength		Margin vs. Peak Limit							
CL	Cable Loss		HPF	High Pass Filter									
f	Dist	Read	AF	CL	Amp	D Corr	Fltr	Corr.	Limit	Margin	Ant. Pol	Det.	Notes
GHz	(m)	dBuV	dB/m	dB	dB	dB	dB	dBuV/m	dBuV/m	dB	V/H	P/A/QP	
<b>LOW CHANNEL, 5180MHz</b>													
15.540	3.0	33.6	38.5	11.3	-32.2	0.0	0.0	51.2	74.0	-22.8	H	P	
15.540	3.0	20.4	38.5	11.3	-32.2	0.0	0.0	38.0	54.0	-16.0	H	A	
15.540	3.0	33.5	38.5	11.3	-32.2	0.0	0.0	51.1	74.0	-22.9	V	P	
15.540	3.0	20.4	38.5	11.3	-32.2	0.0	0.0	38.1	54.0	-15.9	V	A	
<b>HIGH CHANNEL, 5240MHz</b>													
15.720	3.0	32.8	38.0	11.4	-32.2	0.0	0.0	50.1	74.0	-23.9	H	P	
15.720	3.0	20.4	38.0	11.4	-32.2	0.0	0.0	37.6	54.0	-16.4	H	A	
15.720	3.0	32.1	38.0	11.4	-32.2	0.0	0.0	49.4	74.0	-24.6	V	P	
15.720	3.0	20.4	38.0	11.4	-32.2	0.0	0.0	37.6	54.0	-16.4	V	A	
Rev. 4.1.2.7													
Note: No other emissions were detected above the system noise floor.													



### 8.2.3. 802.11n HT40 SISO MODE IN THE LOWER 5.2 GHz BAND

#### RESTRICTED BANDEDGE (LOW CHANNEL, HORIZONTAL)

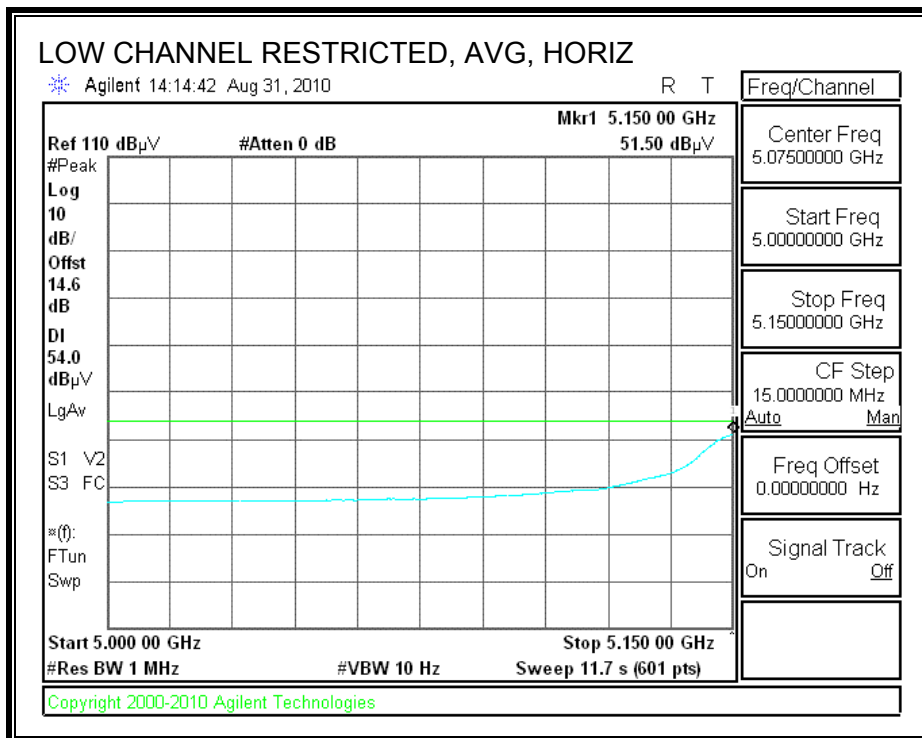
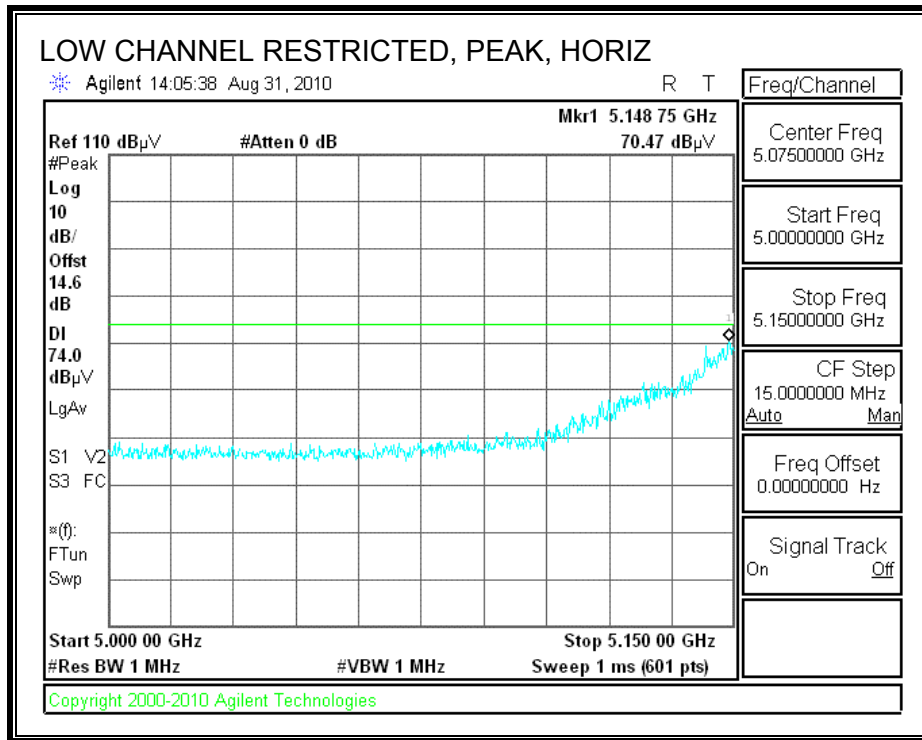

**RESTRICTED BANDEDGE (LOW CHANNEL, VERTICAL)**

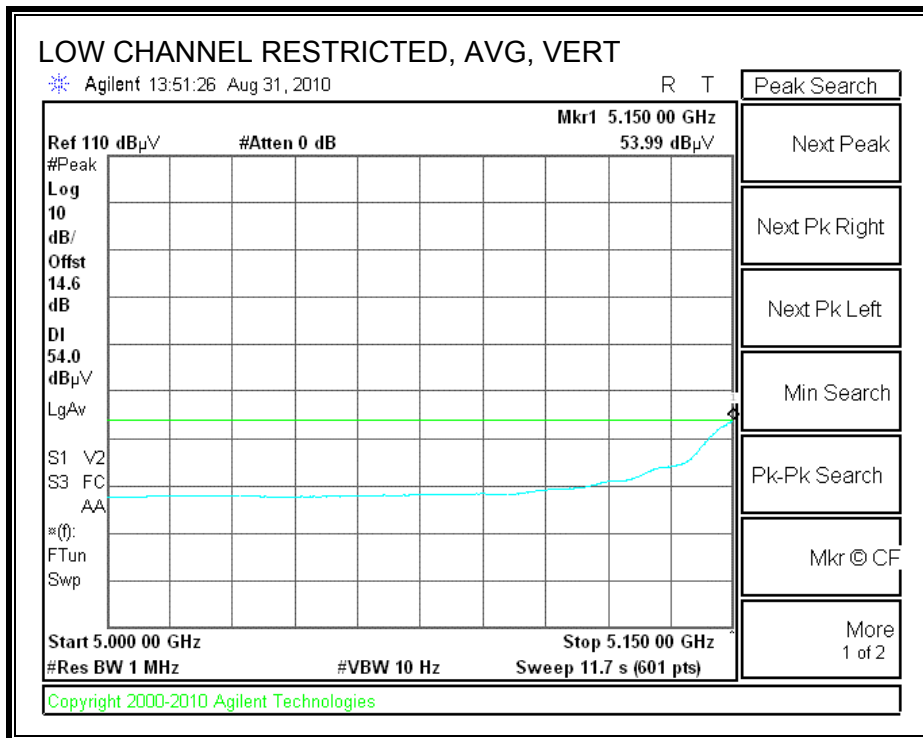
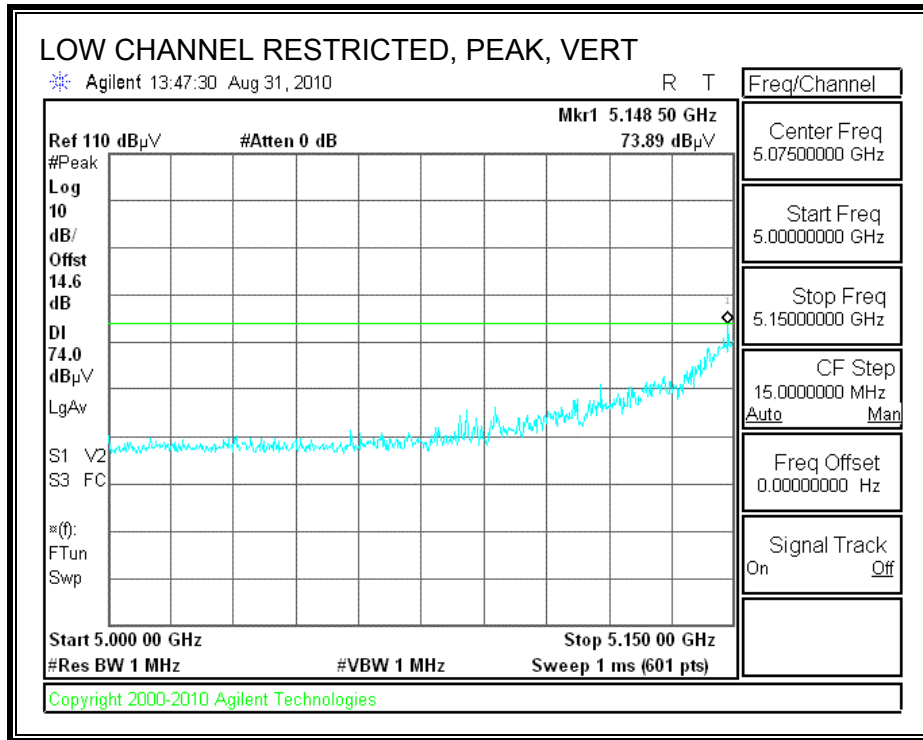

**HARMONICS AND SPURIOUS EMISSIONS**

High Frequency Measurement													
Compliance Certification Services, Fremont 3m Chamber													
Test Engr:		Vien Tran											
Date:		08/31/10											
Project #:		10U13263											
Company:		Broadcom											
EUT Description:		802.11abgn Wlan + bluetooth PCI-E mini card											
EUT M/N:		BCM943224PCIEBT2											
Test Target:		FCC 15.407											
Mode Oper:		TX, 5.2GHz HT40 SISO											
f	Measurement Frequency		Amp	Preamp Gain		Average Field Strength Limit							
Dist	Distance to Antenna		D Corr	Distance Correct to 3 meters		Peak Field Strength Limit							
Read	Analyzer Reading		Avg	Average Field Strength @ 3 m		Margin vs. Average Limit							
AF	Antenna Factor		Peak	Calculated Peak Field Strength		Margin vs. Peak Limit							
CL	Cable Loss		HPF	High Pass Filter									
f	Dist	Read	AF	CL	Amp	D Corr	Fltr	Corr.	Limit	Margin	Ant. Pol.	Det.	Notes
GHz	(m)	dBuV	dB/m	dB	dB	dB	dB	dBuV/m	dBuV/m	dB	V/H	P/A/QP	
<b>Low Channel, 5190MHz</b>													
15.570	3.0	33.1	38.4	11.4	-32.2	0.0	0.0	50.7	74.0	-23.3	H	P	
15.570	3.0	20.8	38.4	11.4	-32.2	0.0	0.0	38.3	54.0	-15.7	H	A	
15.570	3.0	33.0	38.4	11.4	-32.2	0.0	0.0	50.5	74.0	-23.5	V	P	
15.570	3.0	20.7	38.4	11.4	-32.2	0.0	0.0	38.3	54.0	-15.7	V	A	
<b>High Channel, 5230MHz</b>													
15.690	3.0	32.7	38.1	11.4	-32.2	0.0	0.0	50.0	74.0	-24.0	H	P	
15.690	3.0	20.7	38.1	11.4	-32.2	0.0	0.0	38.0	54.0	-16.0	H	A	
15.690	3.0	32.8	38.1	11.4	-32.2	0.0	0.0	50.1	74.0	-23.9	V	P	
15.690	3.0	20.7	38.1	11.4	-32.2	0.0	0.0	38.0	54.0	-16.0	V	A	
Rev. 4.1.2.7													
Note: No other emissions were detected above the system noise floor.													

### 8.2.4. 802.11n HT40 MIMO MODE IN THE LOWER 5.2 GHz BAND

#### HT40 MCS8 SDM –Non - Coherent

#### RESTRICTED BANDEDGE (LOW CHANNEL, HORIZONTAL)

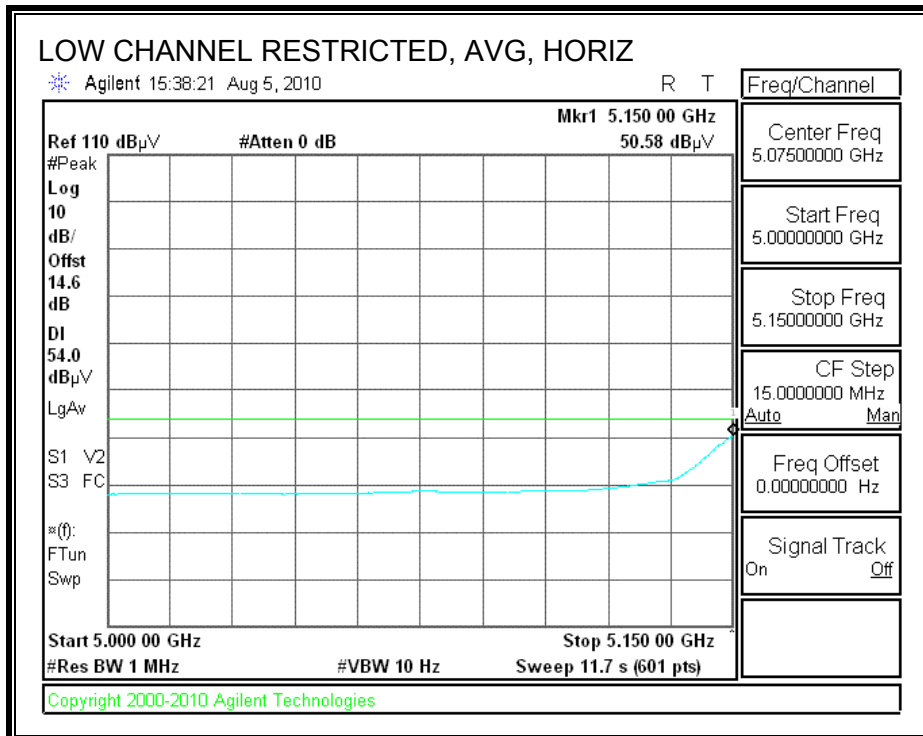
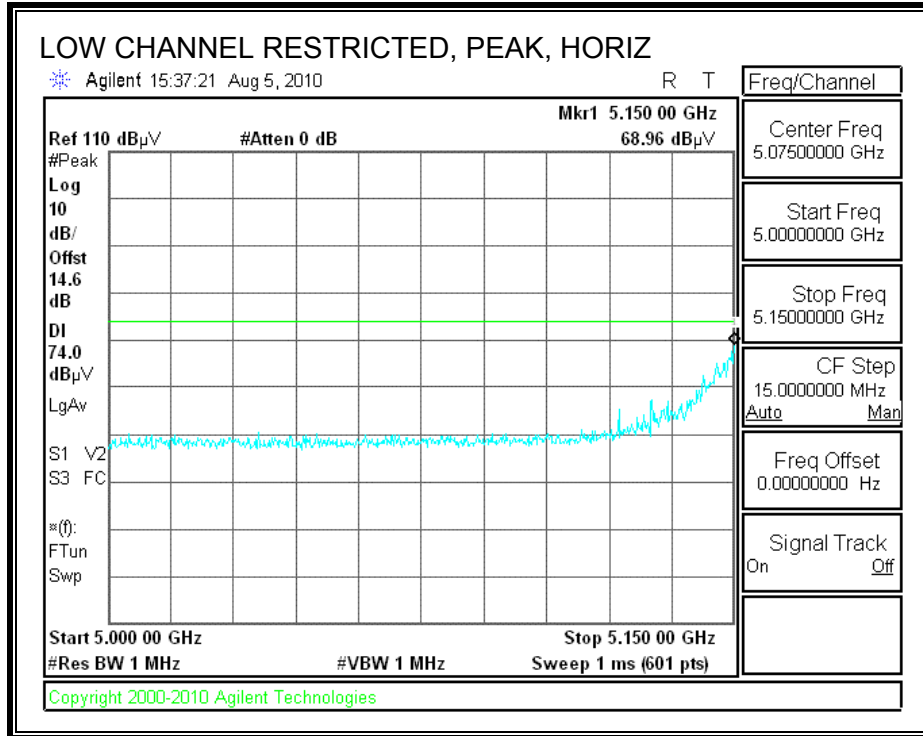

**RESTRICTED BANDEDGE (LOW CHANNEL, VERTICAL)**

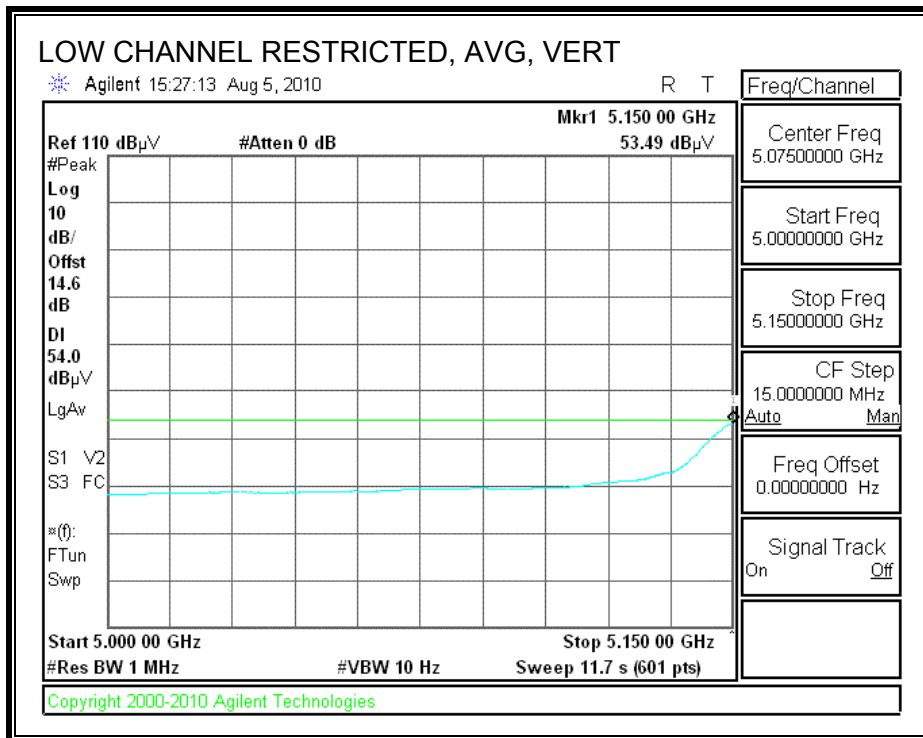
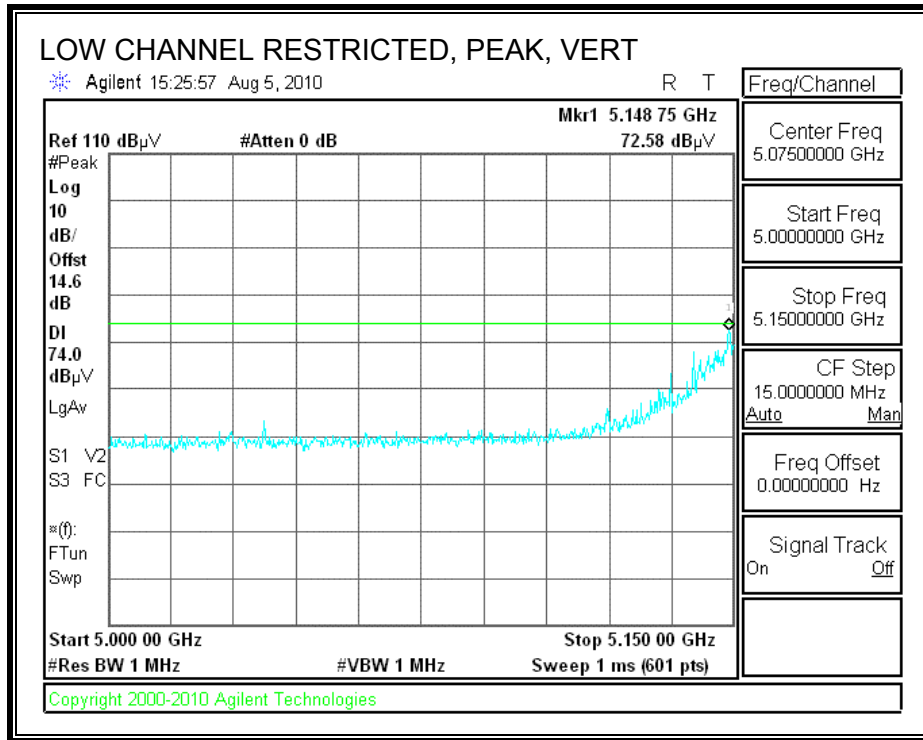

**HARMONICS AND SPURIOUS EMISSIONS**

High Frequency Measurement													
Compliance Certification Services, Fremont 3m Chamber													
Test Engr:		Vien Tran											
Date:		08/12/10											
Project #:		10U13263											
Company:		Broadcom											
EUT Description:		802.11abgn Wlan + bluetooth PCI-E mini card											
EUT M/N:		BCM943224PCIEBT2											
Test Target:		FCC 15.407											
Mode Oper:		HT40 MCS8 SDM Non-coherent											
f	Measurement Frequency			Amp	Preamp Gain			Average Field Strength Limit					
Dist	Distance to Antenna			D Corr	Distance Correct to 3 meters			Peak Field Strength Limit					
Read	Analyzer Reading			Avg	Average Field Strength @ 3 m			Margin vs. Average Limit					
AF	Antenna Factor			Peak	Calculated Peak Field Strength			Margin vs. Peak Limit					
CL	Cable Loss			HPF	High Pass Filter								
f	Dist	Read	AF	CL	Amp	D Corr	Filtr	Corr.	Limit	Margin	Ant. Pol	Det.	Notes
GHz	(m)	dBuV	dB/m	dB	dB	dB	dB	dBuV/m	dBuV/m	dB	V/H	P/A/QP	
<b>LOW CHANNEL, 5190MHz</b>													
15.570	3.0	32.5	38.4	11.4	-32.2	0.0	0.0	50.0	74.0	-24.0	V	P	
15.570	3.0	20.6	38.4	11.4	-32.2	0.0	0.0	38.2	54.0	-15.8	V	A	
15.570	3.0	32.9	38.4	11.4	-32.2	0.0	0.0	50.5	74.0	-23.5	H	P	
15.570	3.0	20.5	38.4	11.4	-32.2	0.0	0.0	38.1	54.0	-15.9	H	A	
<b>HIGH CHANNEL, 5230MHz</b>													
15.690	3.0	34.3	38.4	11.4	-32.2	0.0	0.0	51.9	74.0	-22.1	V	P	
15.690	3.0	21.6	38.4	11.4	-32.2	0.0	0.0	39.2	54.0	-14.8	V	A	
15.690	3.0	34.3	38.4	11.4	-32.2	0.0	0.0	51.8	74.0	-22.2	H	P	
15.690	3.0	21.7	38.4	11.4	-32.2	0.0	0.0	39.3	54.0	-14.7	H	A	
Rev. 4.1.2.7													
Note: No other emissions were detected above the system noise floor.													

**HT40 MCS12 SDM –Non - Coherent**

**RESTRICTED BANDEDGE (LOW CHANNEL, HORIZONTAL)**

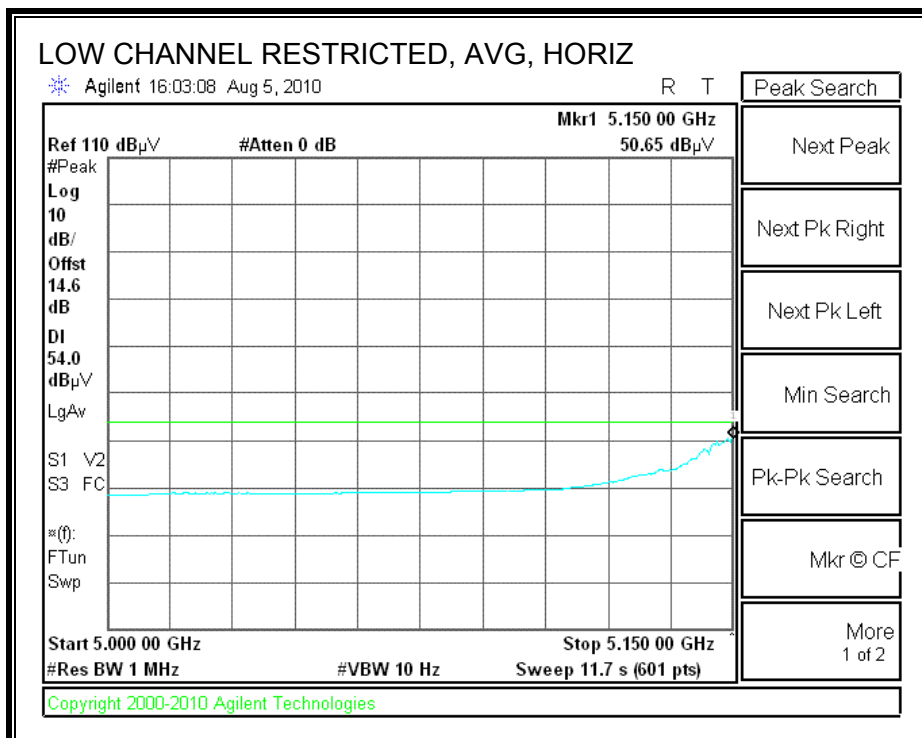
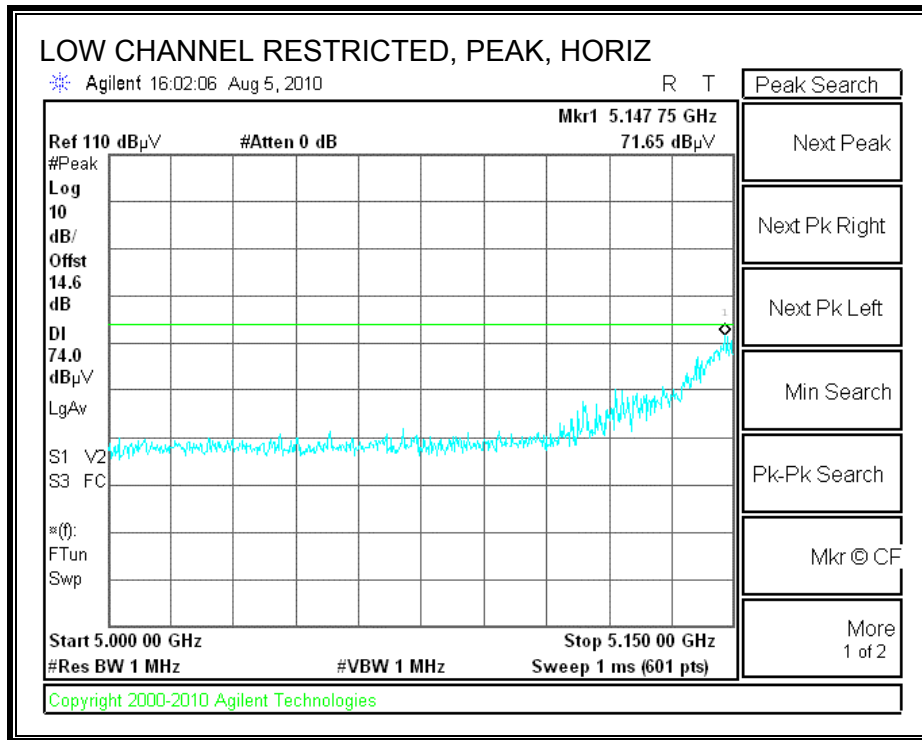

**RESTRICTED BANDEDGE (LOW CHANNEL, VERTICAL)**

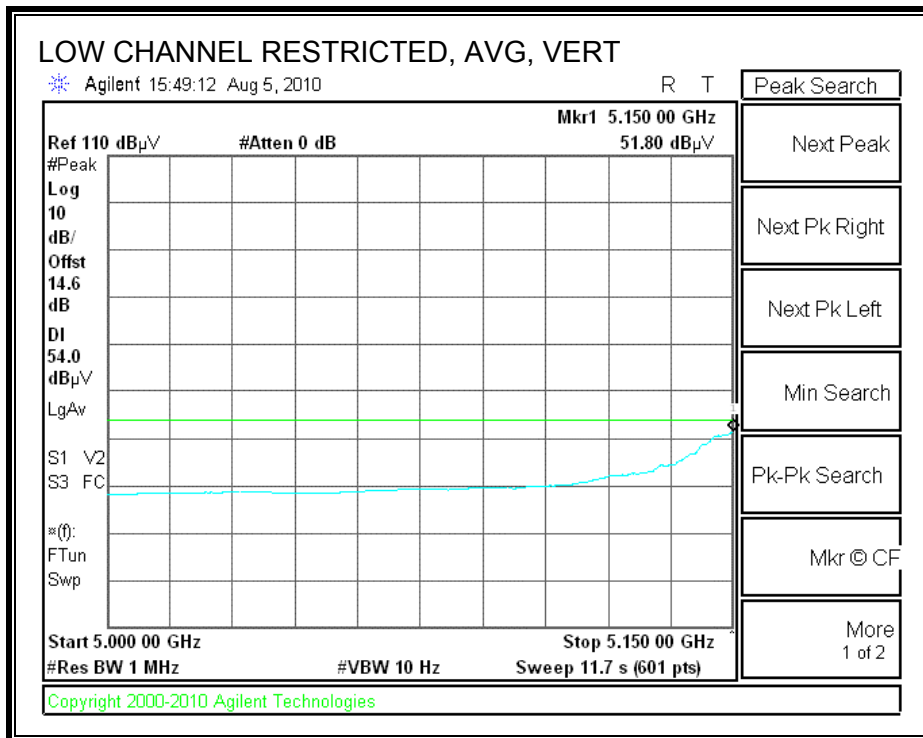
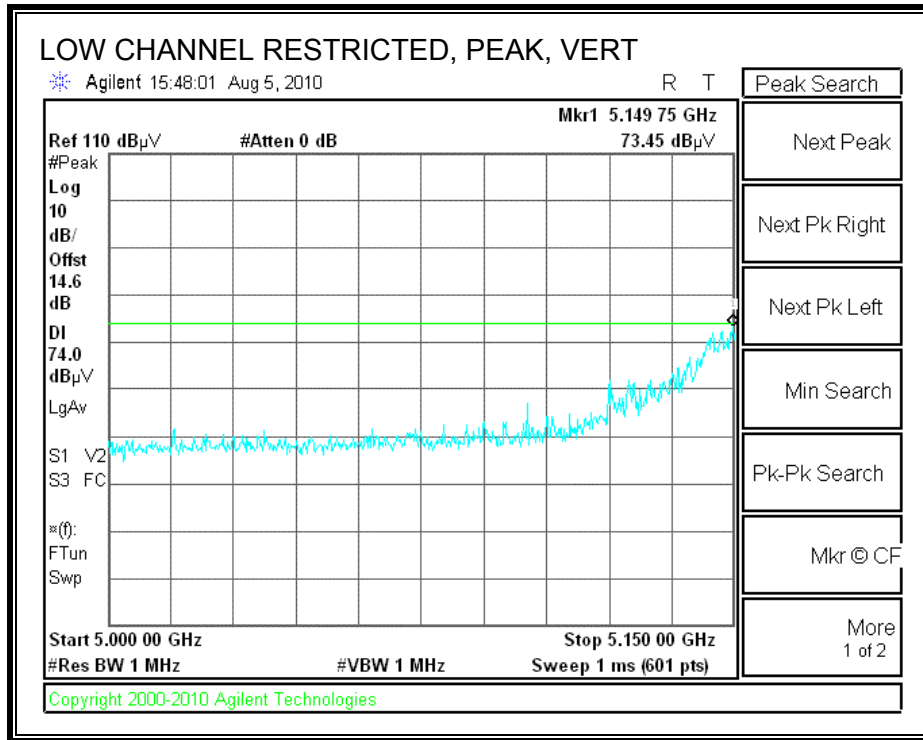



**HARMONICS AND SPURIOUS EMISSIONS**

High Frequency Measurement													
Compliance Certification Services, Fremont 3m Chamber													
Test Engr:		Vien Tran											
Date:		08/12/10											
Project #:		10U13263											
Company:		Broadcom											
EUT Description:		802.11abgn Wlan + bluetooth PCI-E mini card											
EUT M/N:		BCM943224PCIEBT2											
Test Target:		FCC 15.407											
Mode Oper:		HT40 MC12 SDM Non-coherent											
f	Measurement Frequency			Amp	Preamp Gain			Average Field Strength Limit					
Dist	Distance to Antenna			D Corr	Distance Correct to 3 meters			Peak Field Strength Limit					
Read	Analyzer Reading			Avg	Average Field Strength @ 3 m			Margin vs. Average Limit					
AF	Antenna Factor			Peak	Calculated Peak Field Strength			Margin vs. Peak Limit					
CL	Cable Loss			HPF	High Pass Filter								
f	Dist	Read	AF	CL	Amp	D Corr	Filtr	Corr.	Limit	Margin	Ant. Pol.	Det.	Notes
GHz	(m)	dBuV	dB/m	dB	dB	dB	dB	dBuV/m	dBuV/m	dB	V/H	P/A/QP	
<b>LOW CHANNEL, 5190MHz</b>													
15.570	3.0	34.0	38.4	11.4	-32.2	0.0	0.0	51.6	74.0	-22.4	H	P	
15.570	3.0	21.8	38.4	11.4	-32.2	0.0	0.0	39.3	54.0	-14.7	H	A	
15.570	3.0	32.9	38.4	11.4	-32.2	0.0	0.0	50.4	74.0	-23.6	V	P	
15.570	3.0	20.6	38.4	11.4	-32.2	0.0	0.0	38.1	54.0	-15.9	V	A	
<b>HIGH CHANNEL, 5230MHz</b>													
15.570	3.0	32.5	38.4	11.4	-32.2	0.0	0.0	50.1	74.0	-23.9	H	P	
15.570	3.0	20.5	38.4	11.4	-32.2	0.0	0.0	38.1	54.0	-15.9	H	A	
15.570	3.0	32.3	38.4	11.4	-32.2	0.0	0.0	49.9	74.0	-24.1	V	P	
15.570	3.0	20.5	38.4	11.4	-32.2	0.0	0.0	38.1	54.0	-15.9	V	A	
Rev. 4.1.2.7													
Note: No other emissions were detected above the system noise floor.													

### 8.2.5. 802.11a MODE IN THE UPPER 5.3 GHz BAND

#### RESTRICTED BANDEDGE (HIGH CHANNEL, HORIZONTAL)

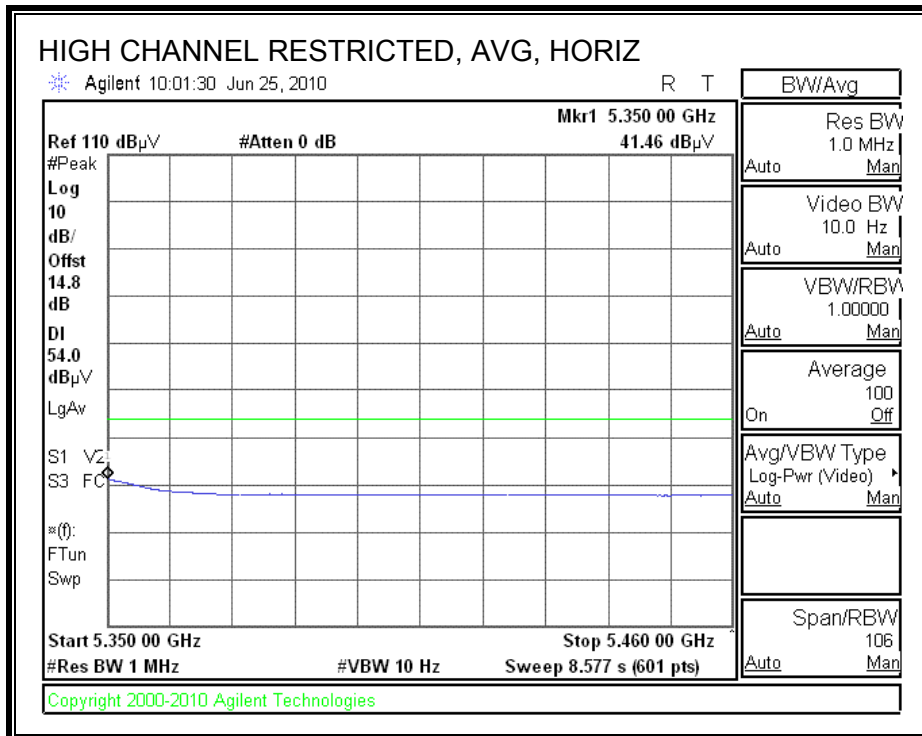
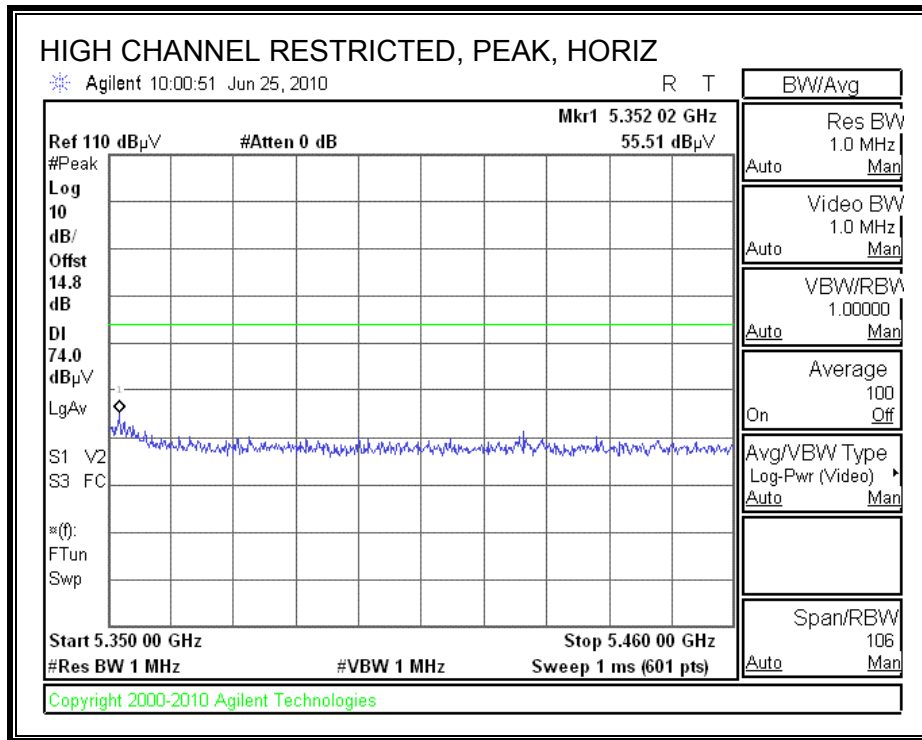

**RESTRICTED BANDEDGE (HIGH CHANNEL, VERTICAL)**

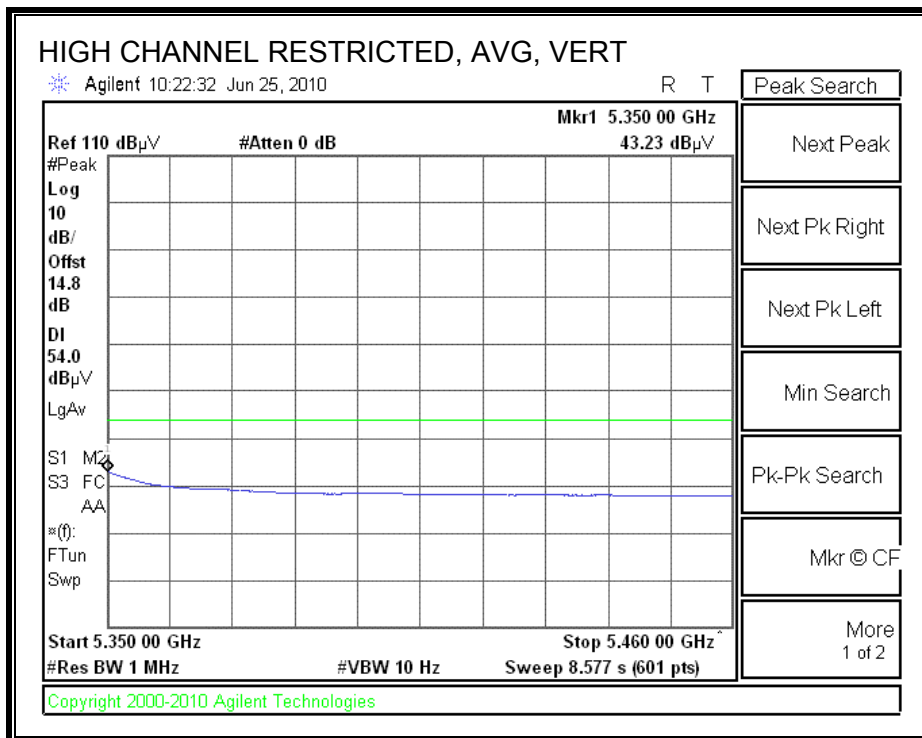
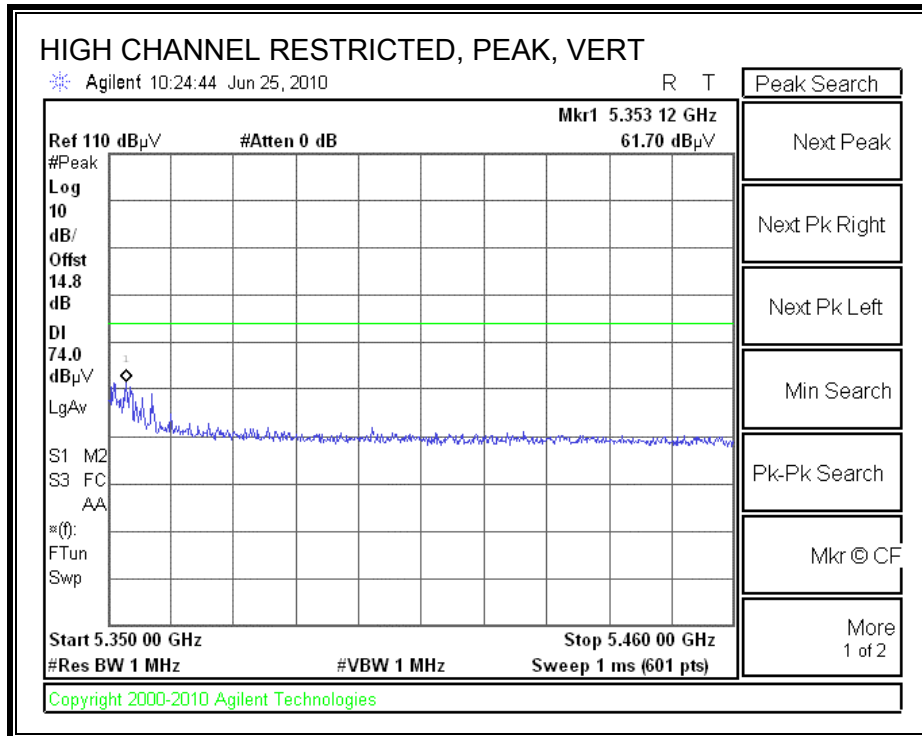

**HARMONICS AND SPURIOUS EMISSIONS**

High Frequency Measurement													
Compliance Certification Services, Fremont 5m Chamber													
Test Engr:		Chin Pang											
Date:		06/29/10											
Project #:		10U13263											
Company:		Broadcom											
EUT Description:		802.11abgn Wlan + bluetooth PCI-E mini card											
EUT M/N:		BCM943224PCIEBT2											
Test Target:		FCC 15.407											
Mode Oper:		TX, 5.3GHz Legacy											
f	Measurement Frequency		Amp	Preamp Gain		Average Field Strength Limit							
Dist	Distance to Antenna		D Corr	Distance Correct to 3 meters		Peak Field Strength Limit							
Read	Analyzer Reading		Avg	Average Field Strength @ 3 m		Margin vs. Average Limit							
AF	Antenna Factor		Peak	Calculated Peak Field Strength		Margin vs. Peak Limit							
CL	Cable Loss		HPF	High Pass Filter									
f	Dist	Read	AF	CL	Amp	D Corr	Filtr	Corr.	Limit	Margin	Ant. Pol	Det	Notes
GHz	(m)	dBuV	dB/m	dB	dB	dB	dB	dBuV/m	dBuV/m	dB	V/H	P/A/QP	
<b>Low Ch, 5260MHz</b>													
15.780	3.0	45.1	37.8	11.5	-32.2	0.0	0.7	63.0	74.0	-11.0	H	P	
15.780	3.0	30.4	37.8	11.5	-32.2	0.0	0.7	48.2	54.0	-5.8	H	A	
15.780	3.0	47.0	37.8	11.5	-32.2	0.0	0.7	64.8	74.0	-9.2	V	P	
15.780	3.0	31.6	37.8	11.5	-32.2	0.0	0.7	49.5	54.0	-4.5	V	A	
<b>Mid Ch, 5300MHz</b>													
10.600	3.0	44.3	37.6	9.0	-32.6	0.0	0.8	59.0	74.0	-15.0	V	P	
10.600	3.0	29.1	37.6	9.0	-32.6	0.0	0.8	43.9	54.0	-10.1	V	A	
15.900	3.0	46.8	37.5	11.5	-32.1	0.0	0.7	64.3	74.0	-9.7	V	P	
15.900	3.0	31.4	37.5	11.5	-32.1	0.0	0.7	48.9	54.0	-5.1	V	A	
10.600	3.0	42.9	37.6	9.0	-32.6	0.0	0.8	57.7	74.0	-16.3	H	P	
10.600	3.0	31.2	37.6	9.0	-32.6	0.0	0.8	46.0	54.0	-8.0	H	A	
15.900	3.0	46.3	37.5	11.5	-32.1	0.0	0.7	63.9	74.0	-10.1	H	P	
15.900	3.0	30.9	37.5	11.5	-32.1	0.0	0.7	48.5	54.0	-5.5	H	A	
<b>High Ch, 5320MHz</b>													
10.640	3.0	40.8	37.6	9.1	-32.6	0.0	0.8	55.6	74.0	-18.4	H	P	
10.640	3.0	29.0	37.6	9.1	-32.6	0.0	0.8	43.8	54.0	-10.2	H	A	
15.960	3.0	39.3	37.3	11.5	-32.1	0.0	0.7	56.7	74.0	-17.3	H	P	
15.960	3.0	24.2	37.3	11.5	-32.1	0.0	0.7	41.6	54.0	-12.4	H	A	
10.640	3.0	38.6	37.6	9.1	-32.6	0.0	0.8	53.4	74.0	-20.6	V	P	
10.640	3.0	26.9	37.6	9.1	-32.6	0.0	0.8	41.7	54.0	-12.3	V	A	
15.960	3.0	43.4	37.3	11.5	-32.1	0.0	0.7	60.8	74.0	-13.2	V	P	
15.960	3.0	26.7	37.3	11.5	-32.1	0.0	0.7	44.1	54.0	-9.9	V	A	
Rev. 4.1.2.7													
Note: No other emissions were detected above the system noise floor.													

### 8.2.6. 802.11n HT20 MODE IN THE UPPER 5.3 GHz BAND

#### RESTRICTED BANDEDGE (HIGH CHANNEL, HORIZONTAL)

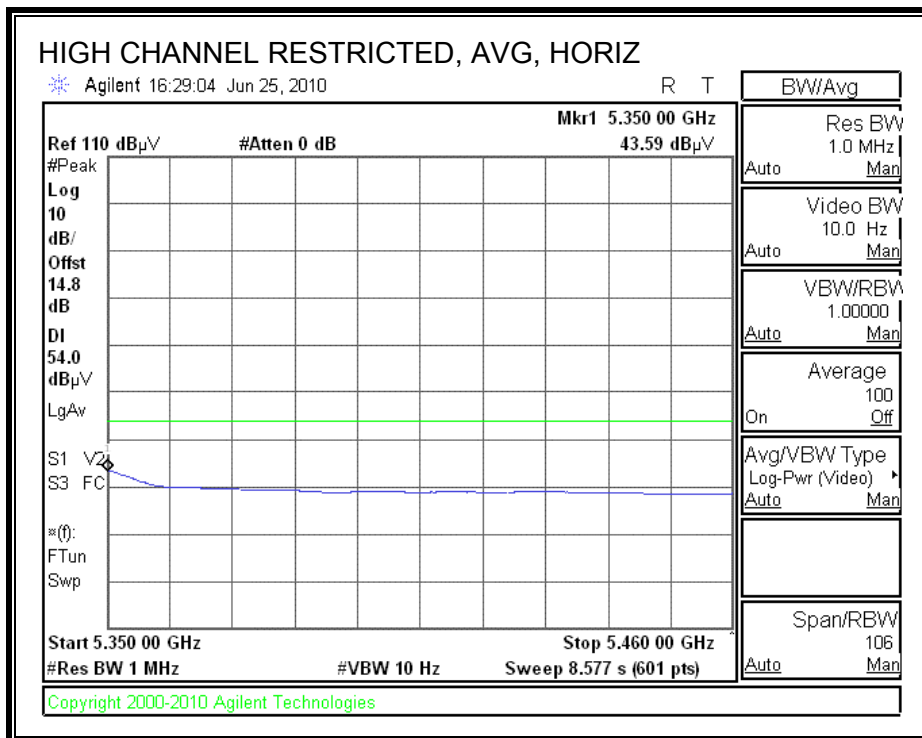
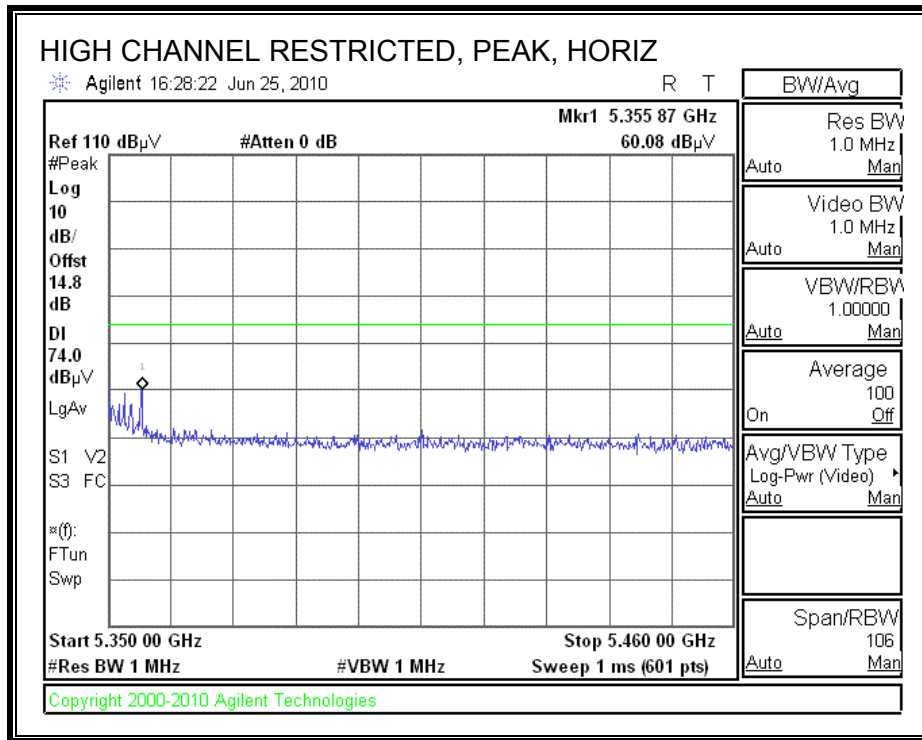

**RESTRICTED BANDEDGE (HIGH CHANNEL, VERT)**

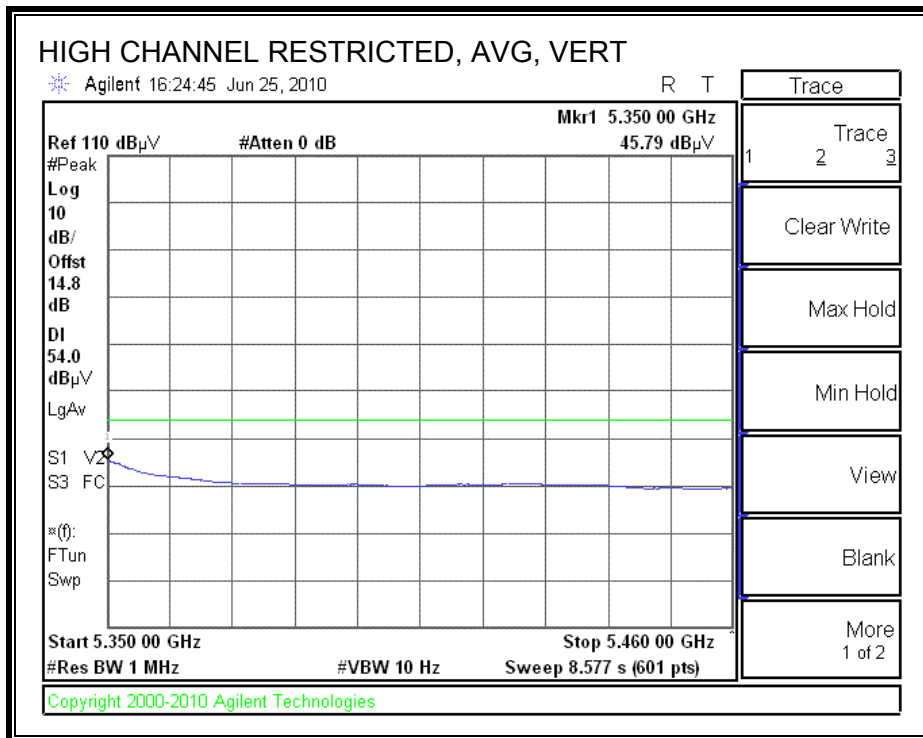
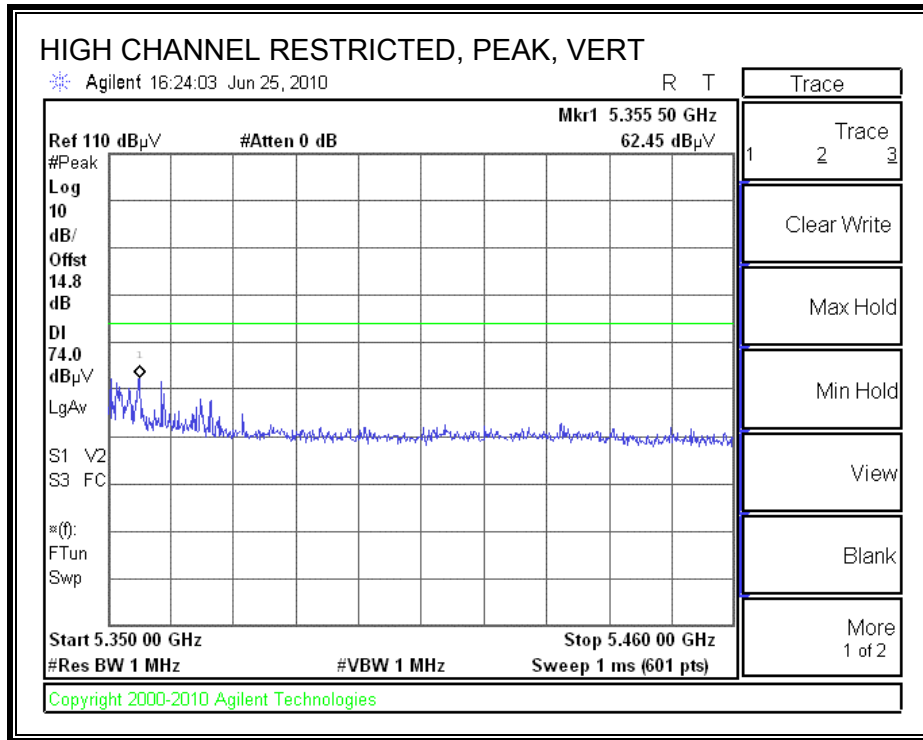

**HARMONICS AND SPURIOUS EMISSIONS**

Compliance Certification Services, Fremont 5m Chamber													
Test Engr:		Chin Pang											
Date:		06/29/10											
Project #:		10U13263											
Company:		Broadcom											
EUT Description:		802.11abgn Wlan + bluetooth PCI-E mini card											
EUT M/N:		BCM943224PCIEBT2											
Test Target:		FCC 15.407											
Mode Oper:		TX, 5.3GHz HT20											
f	Measurement Frequency		Amp	Preamp Gain		Average Field Strength Limit							
Dist	Distance to Antenna		D Corr	Distance Correct to 3 meters		Peak Field Strength Limit							
Read	Analyzer Reading		Avg	Average Field Strength @ 3 m		Margin vs. Average Limit							
AF	Antenna Factor		Peak	Calculated Peak Field Strength		Margin vs. Peak Limit							
CL	Cable Loss		HPF	High Pass Filter									
f GHz	Dist (m)	Read dBuV	AF dB/m	CL dB	Amp dB	D Corr dB	Fltr dB	Corr. dBuV/m	Limit dBuV/m	Margin dB	Ant. Pol. V/H	Det. P/A/QP	Notes
<b>Low Ch, 5260MHz</b>													
15.780	3.0	46.9	37.8	11.5	-32.2	0.0	0.7	64.7	74.0	-9.3	V	P	
15.780	3.0	32.4	37.8	11.5	-32.2	0.0	0.7	50.3	54.0	-3.7	V	A	
15.780	3.0	44.8	37.8	11.5	-32.2	0.0	0.7	62.6	74.0	-11.4	H	P	
15.780	3.0	30.7	37.8	11.5	-32.2	0.0	0.7	48.5	54.0	-5.5	H	A	
<b>Mid Ch, 5300MHz</b>													
10.600	3.0	47.9	37.6	9.0	-32.6	0.0	0.8	62.6	74.0	-11.4	H	P	
10.600	3.0	35.4	37.6	9.0	-32.6	0.0	0.8	50.2	54.0	-3.8	H	A	
15.900	3.0	45.8	37.5	11.5	-32.1	0.0	0.7	63.4	74.0	-10.6	H	P	
15.900	3.0	30.6	37.5	11.5	-32.1	0.0	0.7	48.2	54.0	-5.8	H	A	
10.600	3.0	45.0	37.6	9.0	-32.6	0.0	0.8	59.8	74.0	-14.2	V	P	
10.600	3.0	32.0	37.6	9.0	-32.6	0.0	0.8	46.8	54.0	-7.2	V	A	
15.900	3.0	47.8	37.5	11.5	-32.1	0.0	0.7	65.4	74.0	-8.6	V	P	
15.900	3.0	33.1	37.5	11.5	-32.1	0.0	0.7	50.7	54.0	-3.3	V	A	
<b>High Ch, 5320MHz</b>													
10.640	3.0	43.0	37.6	9.1	-32.6	0.0	0.8	57.8	74.0	-16.2	V	P	
10.640	3.0	29.6	37.6	9.1	-32.6	0.0	0.8	44.4	54.0	-9.6	V	A	
15.960	3.0	40.3	37.3	11.5	-32.1	0.0	0.7	57.7	74.0	-16.3	V	P	
15.960	3.0	25.4	37.3	11.5	-32.1	0.0	0.7	42.8	54.0	-11.2	V	A	
10.640	3.0	44.6	37.6	9.1	-32.6	0.0	0.8	59.4	74.0	-14.6	H	P	
10.640	3.0	31.6	37.6	9.1	-32.6	0.0	0.8	46.4	54.0	-7.6	H	A	
15.960	3.0	39.2	37.3	11.5	-32.1	0.0	0.7	56.6	74.0	-17.4	H	P	
15.960	3.0	24.2	37.3	11.5	-32.1	0.0	0.7	41.6	54.0	-12.4	H	A	
Rev. 4.1.2.7													
Note: No other emissions were detected above the system noise floor.													

### 8.2.7. 802.11n HT40 SISO MODE IN THE UPPER 5.3 GHz BAND

#### RESTRICTED BANDEDGE (HIGH CHANNEL, HORIZONTAL)

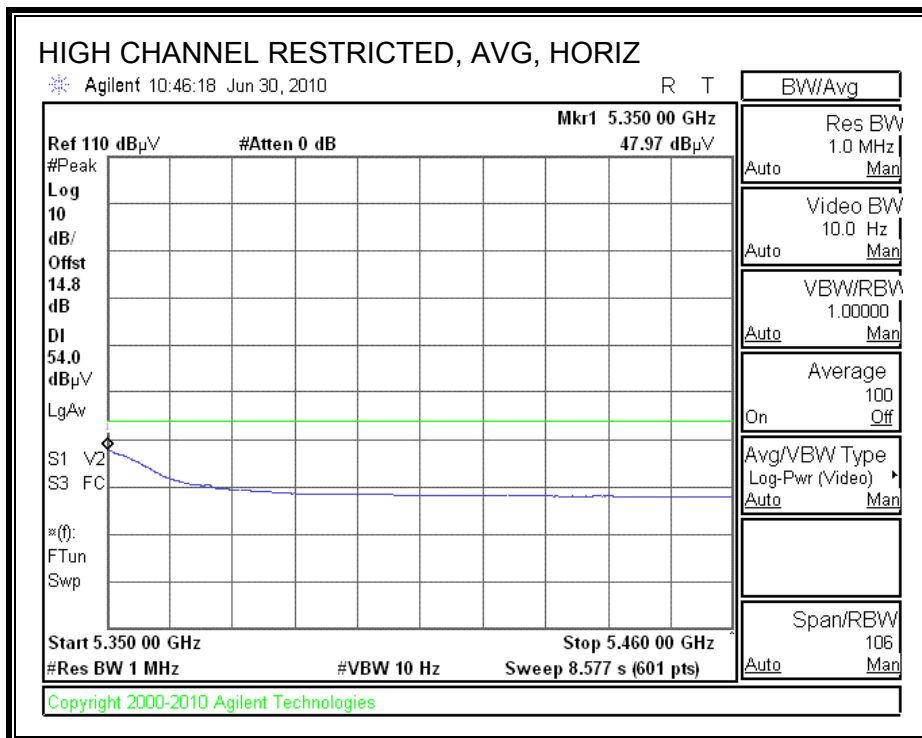
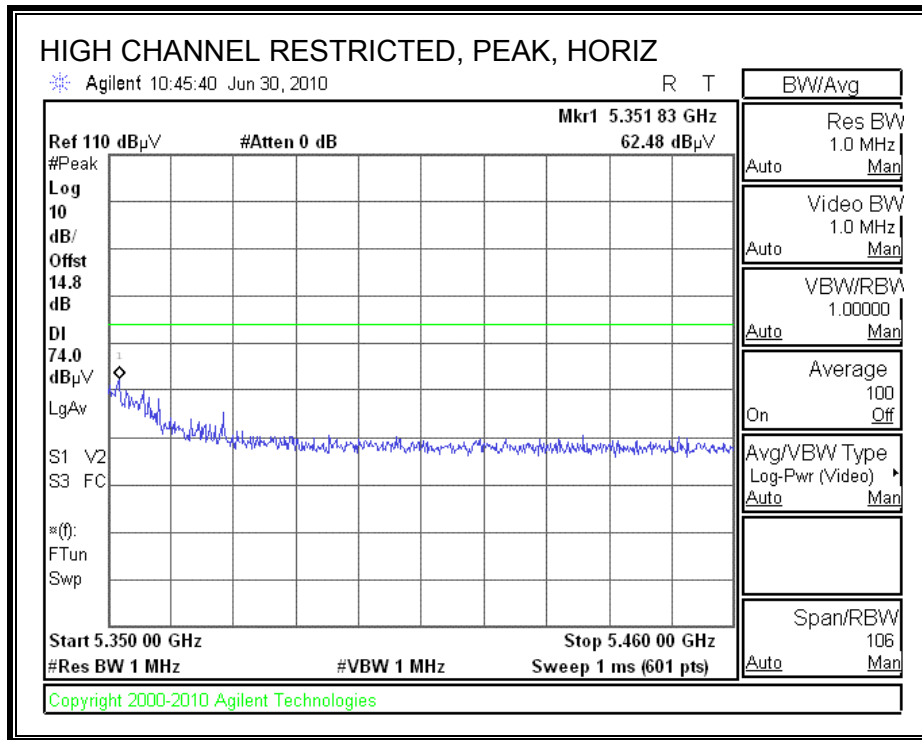



**RESTRICTED BANDEDGE (HIGH CHANNEL, VERTICAL)**

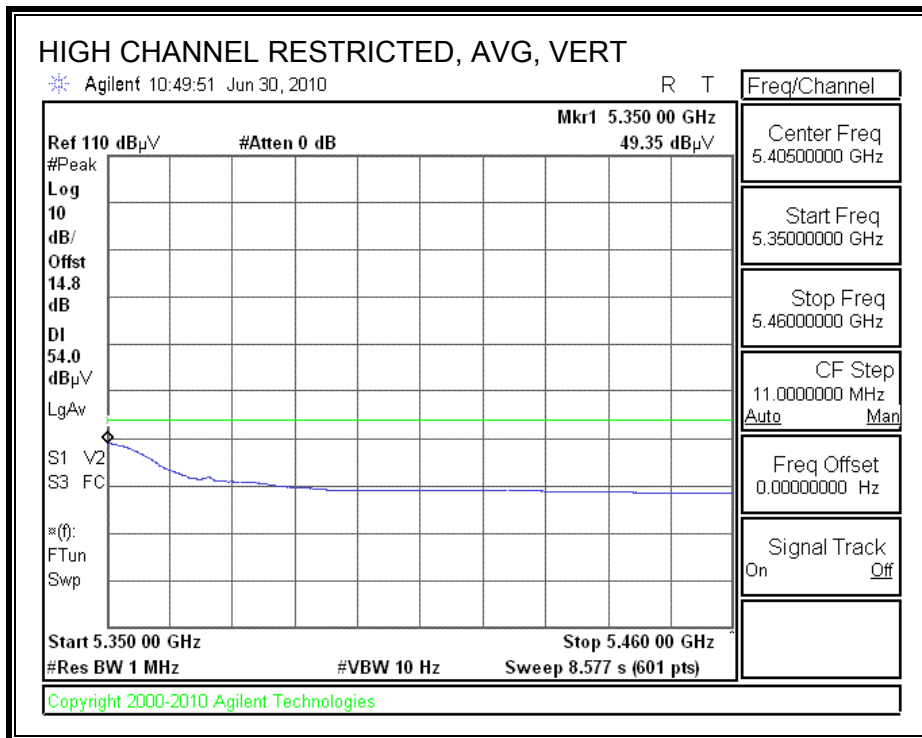
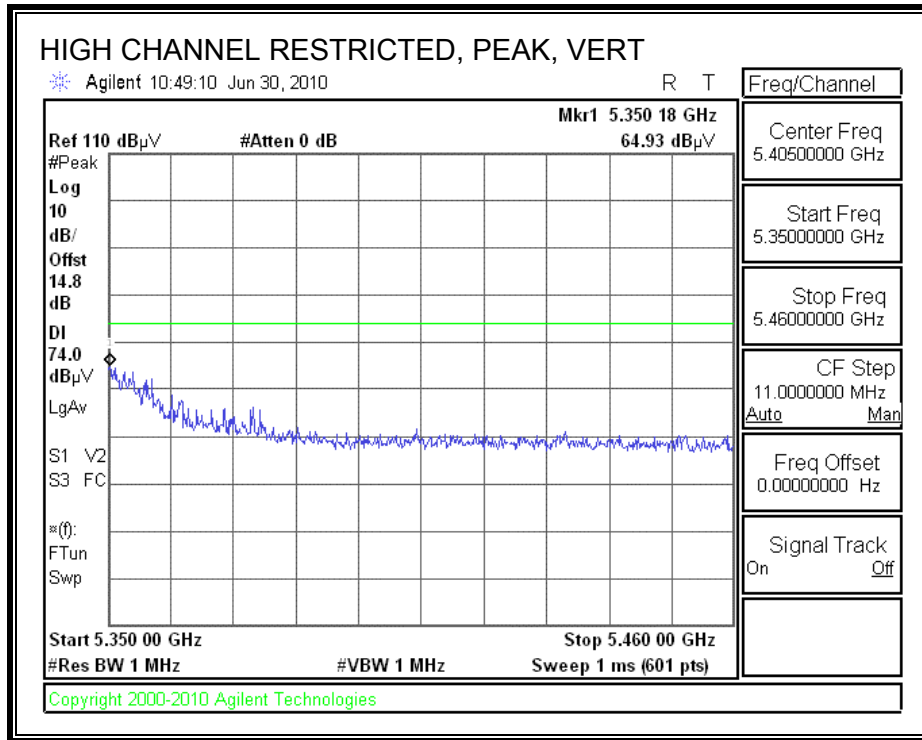

**HARMONICS AND SPURIOUS EMISSIONS**

High Frequency Measurement													
Compliance Certification Services, Fremont 5m Chamber													
Test Engr:		Chi n Pang											
Date:		06/30/10											
Project #:		10U13263											
Company:		Broadcom											
EUT Description:		802.11abgn Wlan + bluetooth PCI-E mini card											
EUT M/N:		BCM943224PCIEBT2											
Test Target:		FCC 15.407											
Mode Oper:		TX, 5.3GHz HT40 SISO											
f	Measurement Frequency		Amp	Preamp Gain		Average Field Strength Limit							
Dist	Distance to Antenna		D Corr	Distance Correct to 3 meters		Peak Field Strength Limit							
Read	Analyzer Reading		Avg	Average Field Strength @ 3 m		Margin vs. Average Limit							
AF	Antenna Factor		Peak	Calculated Peak Field Strength		Margin vs. Peak Limit							
CL	Cable Loss		HPF	High Pass Filter									
f	Dist	Read	AF	CL	Amp	D Corr	Filtr	Corr.	Limit	Margin	Ant. Pol.	Det.	Notes
GHz	(m)	dBuV	dB/m	dB	dB	dB	dB	dBuV/m	dBuV/m	dB	V/H	P/A/QP	
<b>Low Ch, 5270MHz</b>													
15.810	3.0	41.4	37.7	11.5	-32.2	0.0	0.7	59.2	74.0	-14.8	H	P	
15.810	3.0	27.2	37.7	11.5	-32.2	0.0	0.7	45.0	54.0	-9.0	H	A	
15.810	3.0	41.9	37.7	11.5	-32.2	0.0	0.7	59.6	74.0	-14.4	V	P	
15.810	3.0	28.4	37.7	11.5	-32.2	0.0	0.7	46.2	54.0	-7.8	V	A	
<b>High Ch, 5310MHz</b>													
10.620	3.0	38.2	37.6	9.1	-32.6	0.0	0.8	52.9	74.0	-21.1	V	P	
10.620	3.0	25.7	37.6	9.1	-32.6	0.0	0.8	40.5	54.0	-13.5	V	A	
15.930	3.0	40.0	37.4	11.5	-32.1	0.0	0.7	57.5	74.0	-16.5	V	P	
15.930	3.0	25.4	37.4	11.5	-32.1	0.0	0.7	42.9	54.0	-11.1	V	A	
10.620	3.0	39.7	37.6	9.1	-32.6	0.0	0.8	54.5	74.0	-19.5	H	P	
10.620	3.0	28.1	37.6	9.1	-32.6	0.0	0.8	42.9	54.0	-11.1	H	A	
15.930	3.0	38.5	37.4	11.5	-32.1	0.0	0.7	56.0	74.0	-18.0	H	P	
15.930	3.0	25.0	37.4	11.5	-32.1	0.0	0.7	42.5	54.0	-11.5	H	A	
Rev. 4.1.2.7													
Note: No other emissions were detected above the system noise floor.													

### 8.2.8. 802.11n HT40 MIMO MCS0 MODE IN THE UPPER 5.3 GHz BAND

#### RESTRICTED BANDEDGE (HIGH CHANNEL, HORIZONTAL)

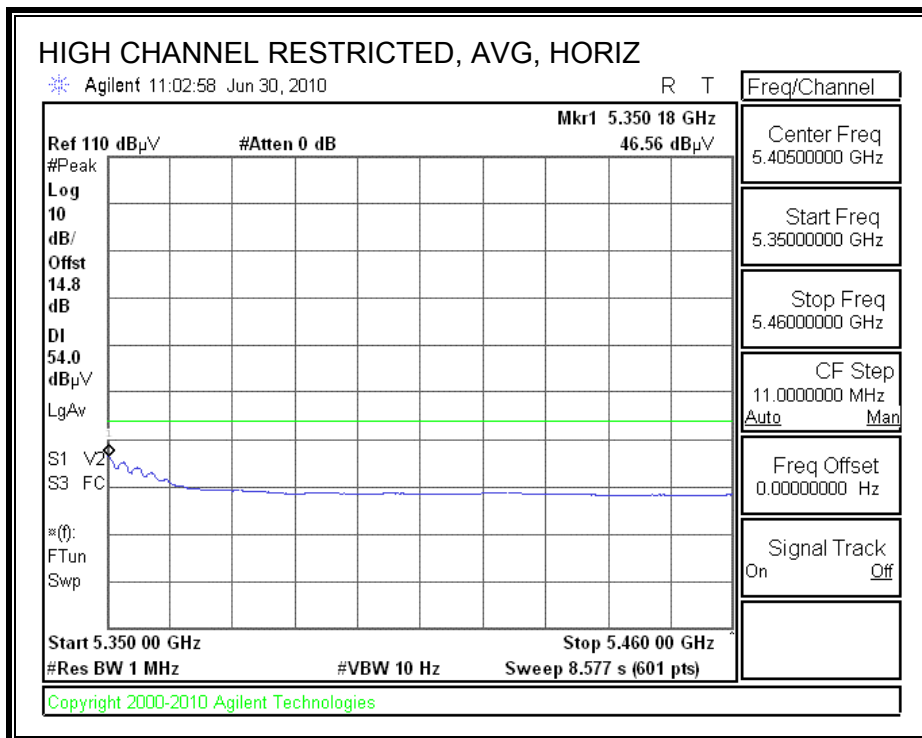
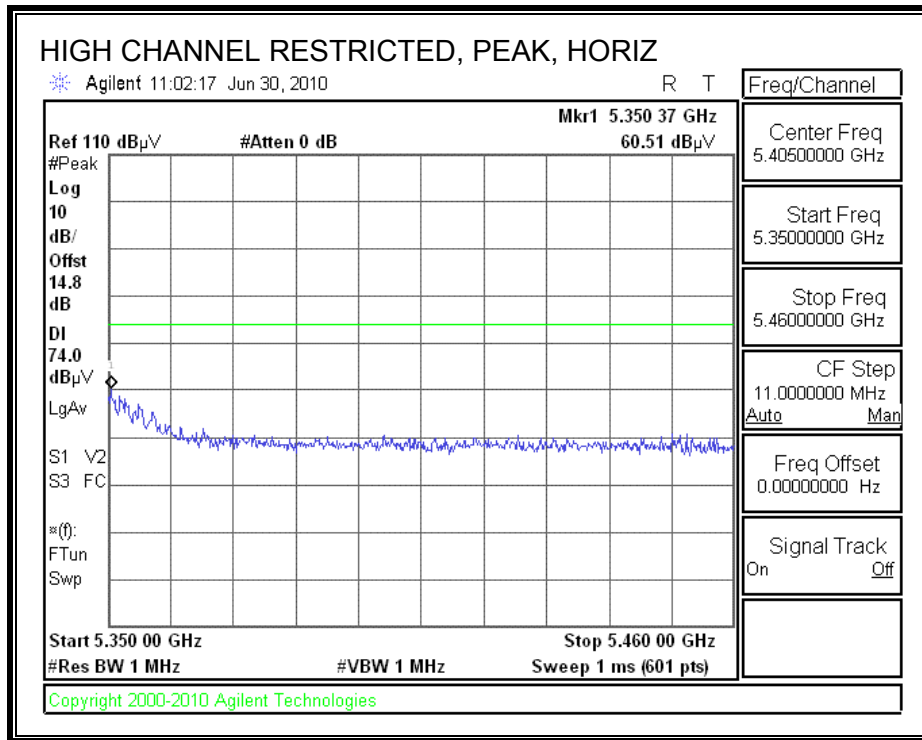

**RESTRICTED BANDEDGE (HIGH CHANNEL, VERTICAL)**

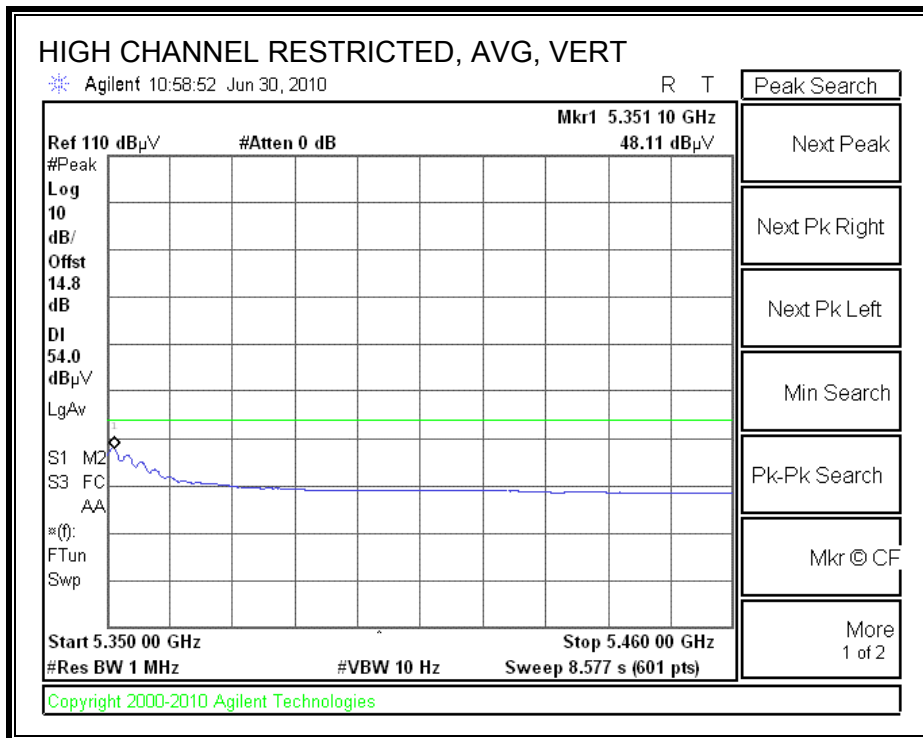
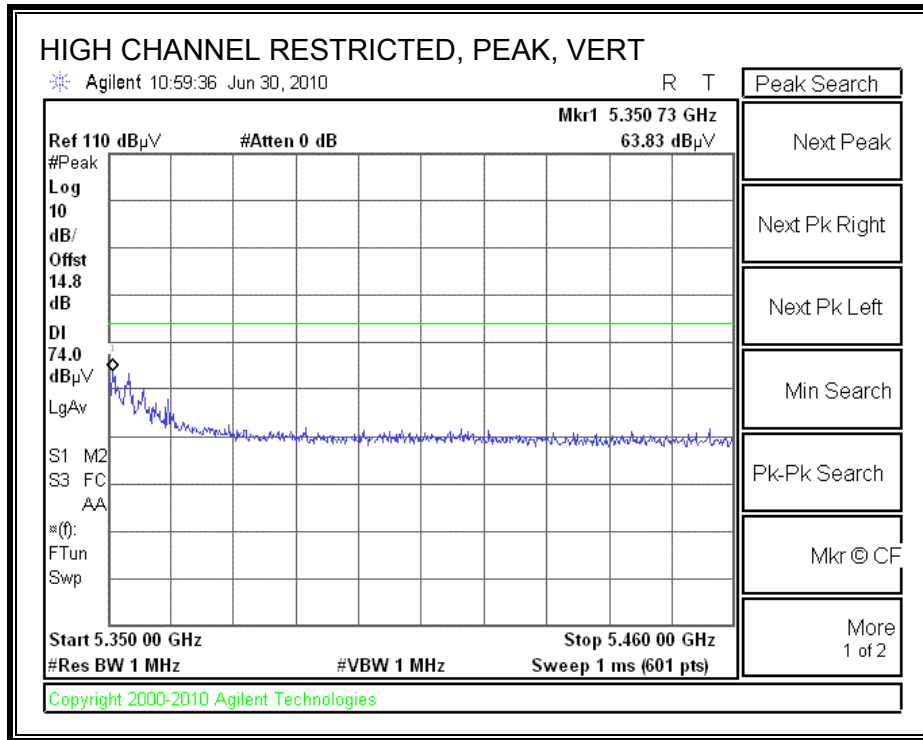

**HARMONICS AND SPURIOUS EMISSIONS**

High Frequency Measurement													
Compliance Certification Services, Fremont 5m Chamber													
Test Engr:		Chin Pang											
Date:		06/30/10											
Project #:		10U13263											
Company:		Broadcom											
EUT Description:		802.11abgn Wlan + bluetooth PCI-E mini card											
EUT M/N:		BCM943224PCIEBT2											
Test Target:		FCC 15.407											
Mode Oper:		TX, 5.3GHz HT40 MIMO											
f	Measurement Frequency		Amp	Preamp Gain		Average Field Strength Limit							
Dist	Distance to Antenna		D Corr	Distance Correct to 3 meters		Peak Field Strength Limit							
Read	Analyzer Reading		Avg	Average Field Strength @ 3 m		Margin vs. Average Limit							
AF	Antenna Factor		Peak	Calculated Peak Field Strength		Margin vs. Peak Limit							
CL	Cable Loss		HPF	High Pass Filter									
f	Dist	Read	AF	CL	Amp	D Corr	Filtr	Corr.	Limit	Margin	Ant. Pol.	Det.	Notes
GHz	(m)	dBuV	dB/m	dB	dB	dB	dB	dBuV/m	dBuV/m	dB	V/H	P/A/QP	
<b>Low Ch, 5270MHz</b>													
15.810	3.0	40.4	37.7	11.5	-32.2	0.0	0.7	58.1	74.0	-15.9	H	P	
15.810	3.0	27.2	37.7	11.5	-32.2	0.0	0.7	44.9	54.0	-9.1	H	A	
15.810	3.0	41.0	37.7	11.5	-32.2	0.0	0.7	58.8	74.0	-15.2	V	P	
15.810	3.0	28.2	37.7	11.5	-32.2	0.0	0.7	46.0	54.0	-8.0	V	A	
<b>High Ch, 5310MHz</b>													
10.620	3.0	42.4	37.6	9.1	-32.6	0.0	0.8	57.2	74.0	-16.8	V	P	
10.620	3.0	29.1	37.6	9.1	-32.6	0.0	0.8	43.9	54.0	-10.1	V	A	
15.930	3.0	39.3	37.4	11.5	-32.1	0.0	0.7	56.8	74.0	-17.2	V	P	
15.930	3.0	25.8	37.4	11.5	-32.1	0.0	0.7	43.3	54.0	-10.7	V	A	
10.620	3.0	39.7	37.6	9.1	-32.6	0.0	0.8	54.5	74.0	-19.5	H	P	
10.620	3.0	28.3	37.6	9.1	-32.6	0.0	0.8	43.0	54.0	-11.0	H	A	
15.930	3.0	37.5	37.4	11.5	-32.1	0.0	0.7	55.0	74.0	-19.0	H	P	
15.930	3.0	24.8	37.4	11.5	-32.1	0.0	0.7	42.3	54.0	-11.7	H	A	
Rev. 4.1.2.7													
Note: No other emissions were detected above the system noise floor.													

### 8.2.9. 802.11a MODE IN THE 5.6 GHz BAND

#### RESTRICTED BANDEDGE (LOW CHANNEL, HORIZONTAL)

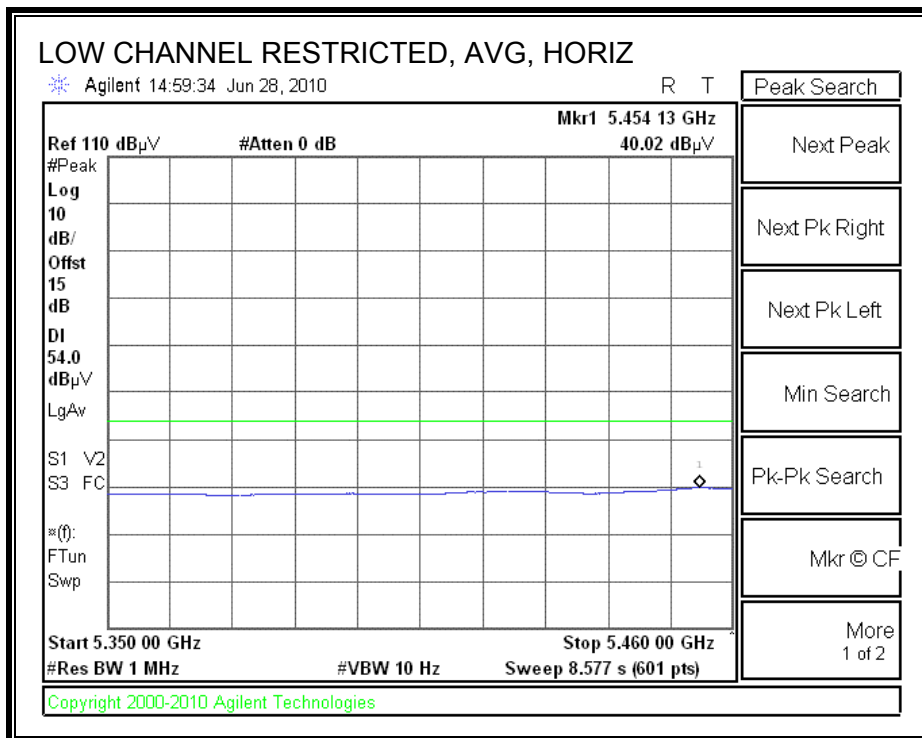
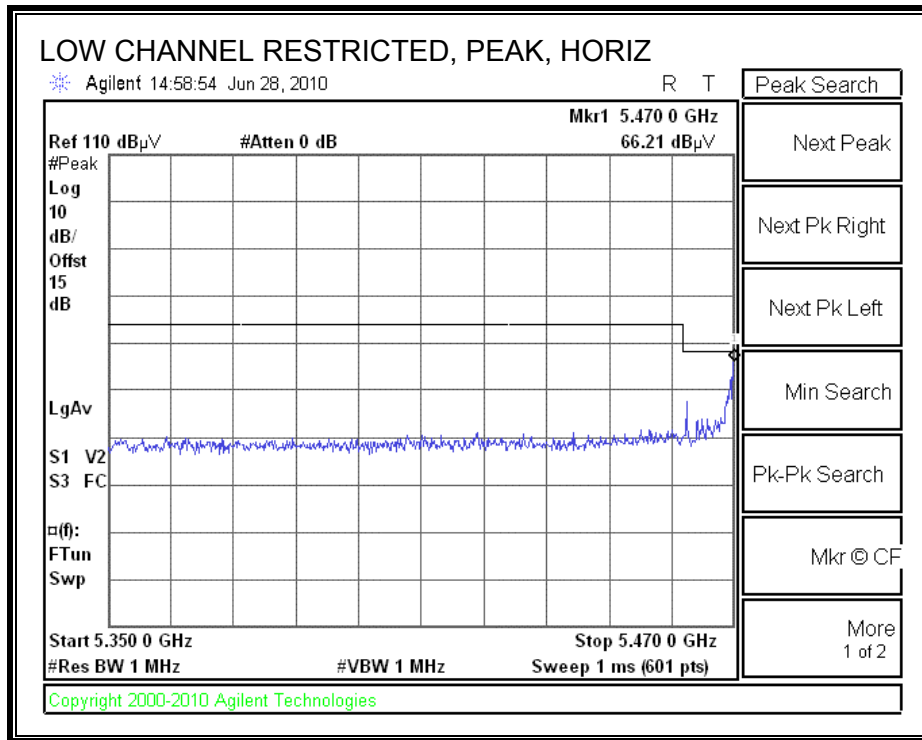

**RESTRICTED BANDEDGE (LOW CHANNEL, VERTICAL)**

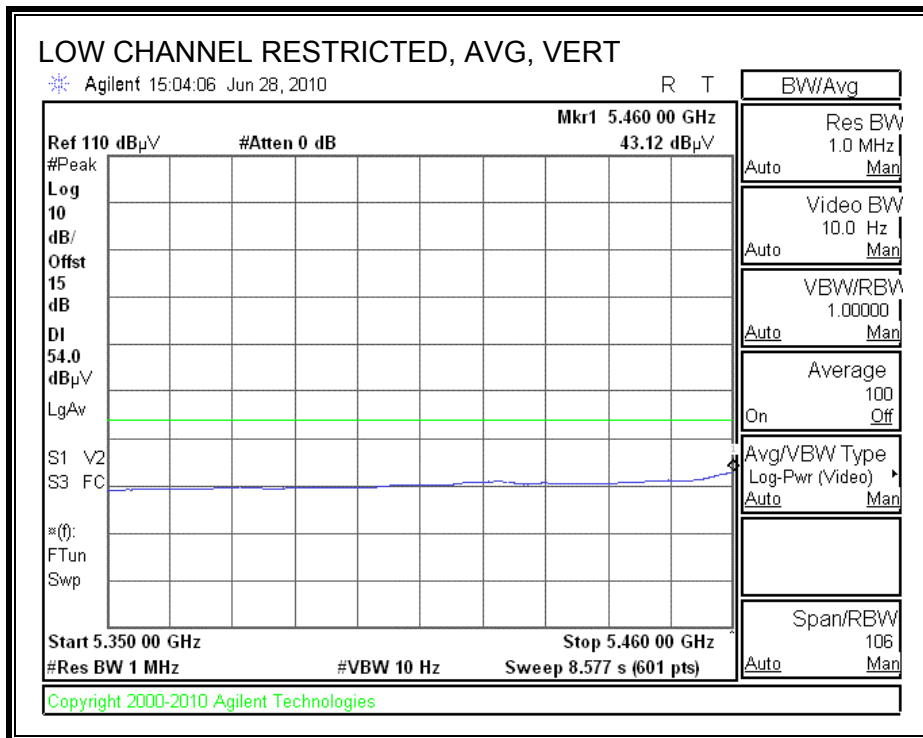
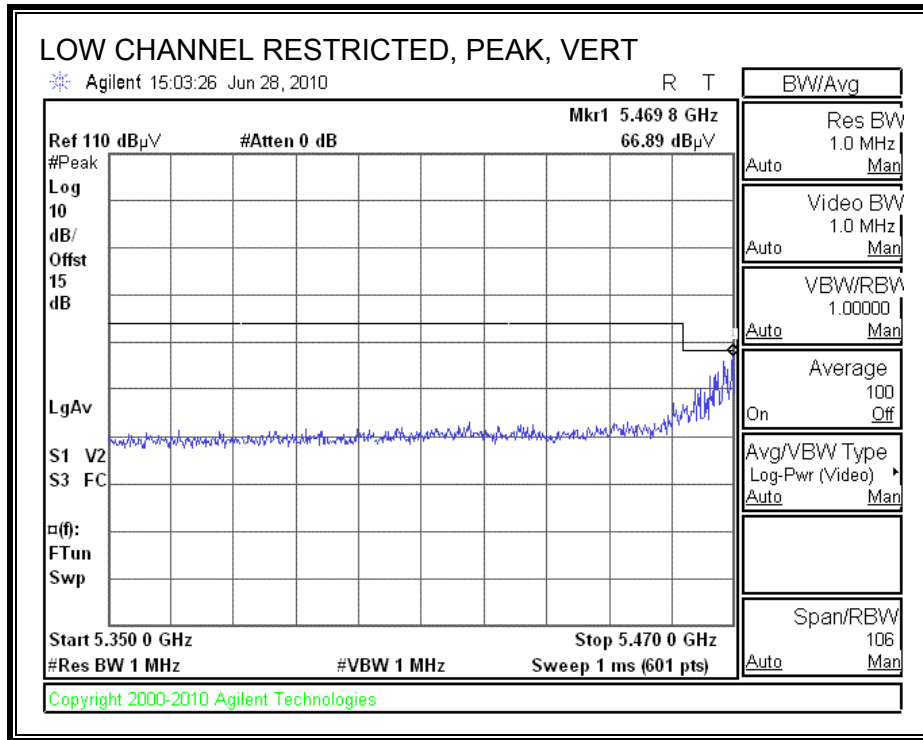

**AUTHORIZED BANDEDGE (HIGH CHANNEL, HORIZONTAL)**

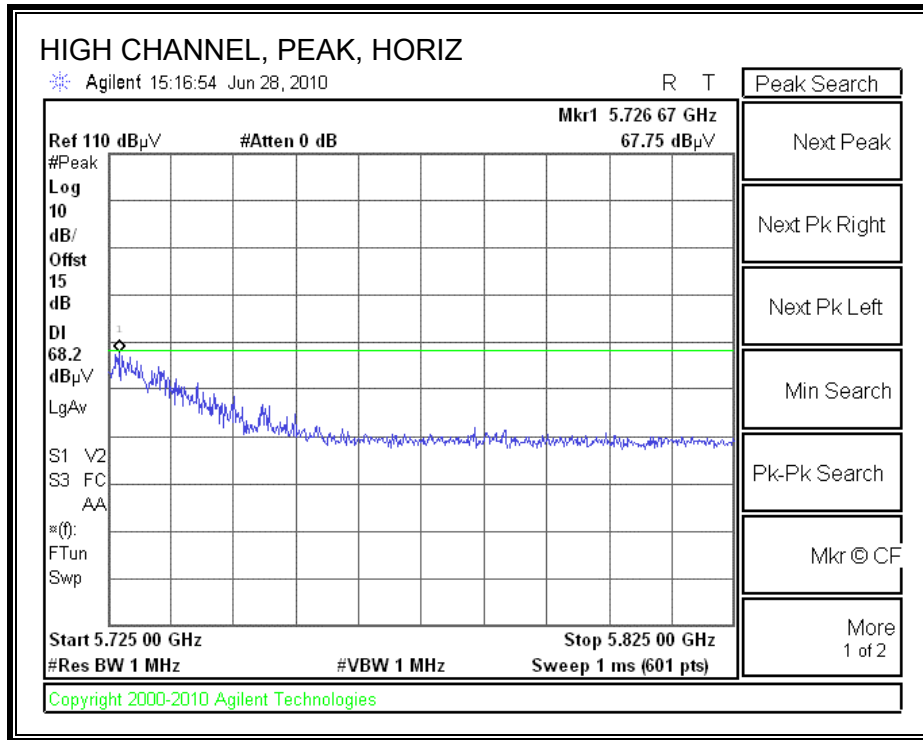

**AUTHORIZED BANDEDGE (HIGH CHANNEL, VERTICAL)**

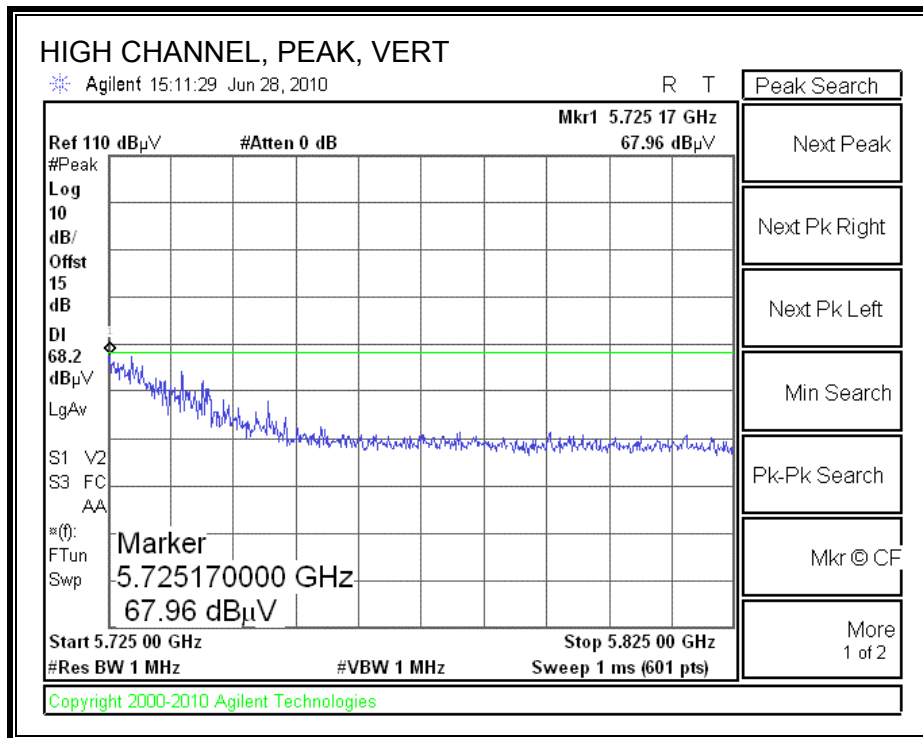



**HARMONICS AND SPURIOUS EMISSIONS**

High Frequency Measurement													
Compliance Certification Services, Fremont 5m Chamber													
Test Engr:		Chin Pang											
Date:		06/29/10											
Project #:		10U13263											
Company:		Broadcom											
EUT Description:		802.11abgn Wlan + bluetooth PCI-E mini card											
EUT M/N:		BCM943224PCIEBT2											
Test Target:		FCC 15.407											
Mode Oper:		TX, 5.6GHz Legacy											
f	Measurement Frequency			Amp	Preamp Gain			Average Field Strength Limit					
Dist	Distance to Antenna			D Corr	Distance Correct to 3 meters			Peak Field Strength Limit					
Read	Analyzer Reading			Avg	Average Field Strength @ 3 m			Margin vs. Average Limit					
AF	Antenna Factor			Peak	Calculated Peak Field Strength			Margin vs. Peak Limit					
CL	Cable Loss			HPF	High Pass Filter								
f GHz	Dist (m)	Read dBuV	AF dB/m	CL dB	Amp dB	D Corr dB	Filtr dB	Corr. dBuV/m	Limit dBuV/m	Margin dB	Ant. Pol. V/H	Det. P/A/QP	Notes
<b>Low Ch, 5500MHz</b>													
11.000	3.0	40.9	37.6	9.2	-32.6	0.0	0.7	55.9	74.0	-18.2	V	P	
11.000	3.0	27.5	37.6	9.2	-32.6	0.0	0.7	42.5	54.0	-11.5	V	A	
11.000	3.0	41.5	37.6	9.2	-32.6	0.0	0.7	56.5	74.0	-17.5	H	P	
11.000	3.0	28.3	37.6	9.2	-32.6	0.0	0.7	43.3	54.0	-10.7	H	A	
<b>Mid Ch, 5600MHz</b>													
11.200	3.0	45.5	37.8	9.3	-32.6	0.0	0.7	60.7	74.0	-13.3	H	P	
11.200	3.0	31.4	37.8	9.3	-32.6	0.0	0.7	46.7	54.0	-7.3	H	A	
11.200	3.0	44.4	37.8	9.3	-32.6	0.0	0.7	59.7	74.0	-14.3	V	P	
11.200	3.0	30.3	37.8	9.3	-32.6	0.0	0.7	45.6	54.0	-8.4	V	A	
<b>High Ch, 5700MHz</b>													
11.400	3.0	37.4	38.0	9.4	-32.5	0.0	0.7	52.9	74.0	-21.1	V	P	
11.400	3.0	24.7	38.0	9.4	-32.5	0.0	0.7	40.2	54.0	-13.8	V	A	
11.400	3.0	38.7	38.0	9.4	-32.5	0.0	0.7	54.2	74.0	-19.8	H	P	
11.400	3.0	23.9	38.0	9.4	-32.5	0.0	0.7	39.4	54.0	-14.6	H	A	
Rev. 4.1.2.7													
Note: No other emissions were detected above the system noise floor.													

**8.2.10. 802.11n HT20 MODE IN THE 5.6 GHz BAND**

**RESTRICTED BANDEDGE (LOW CHANNEL, HORIZONTAL)**

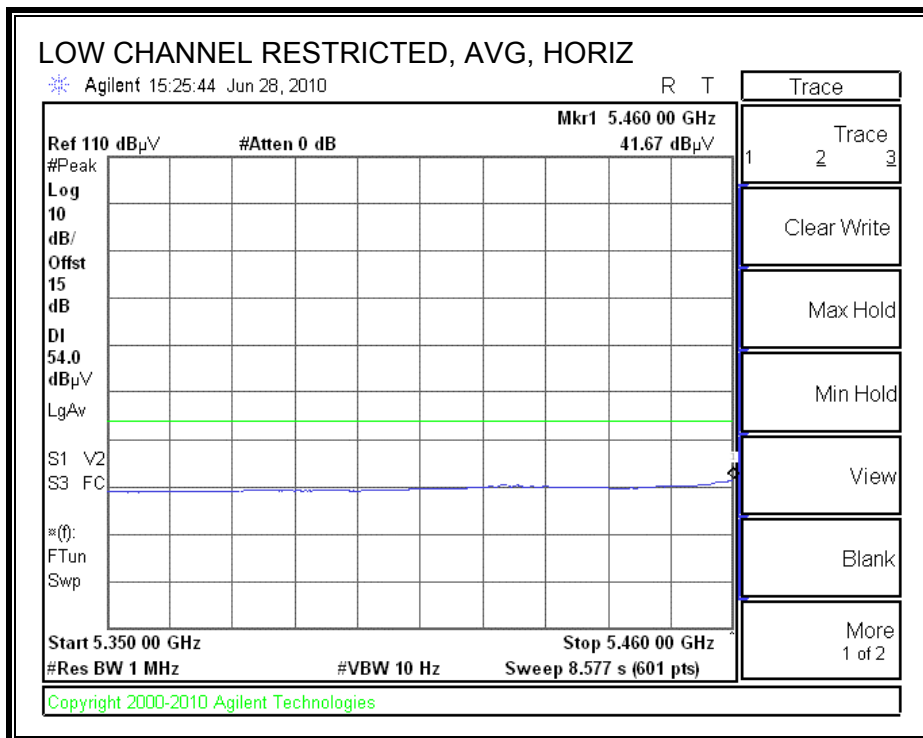
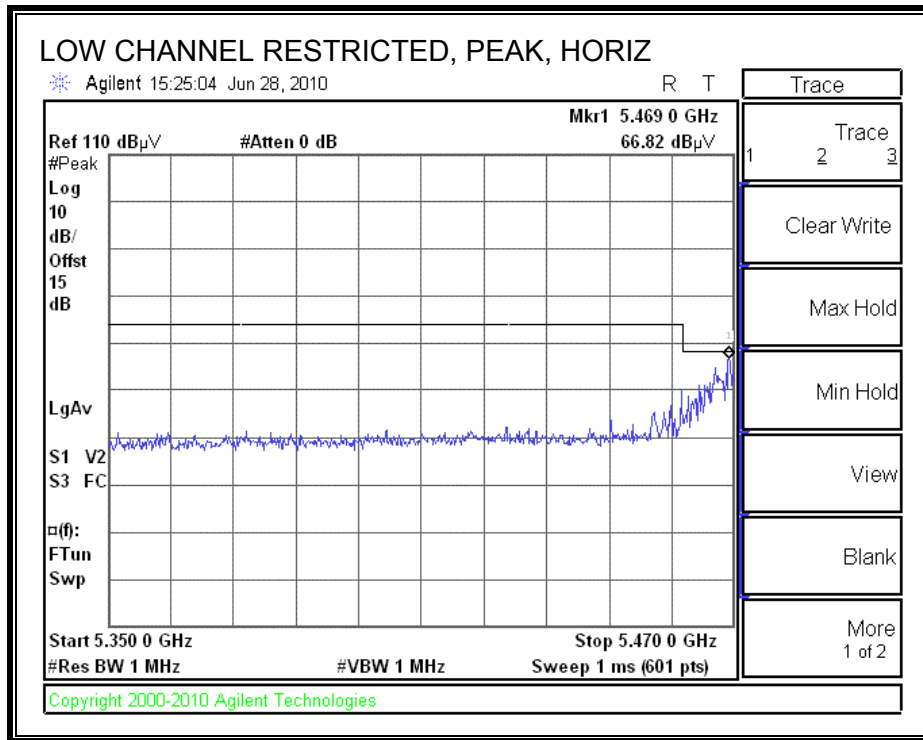

**RESTRICTED BANDEDGE (LOW CHANNEL, VERTICAL)**

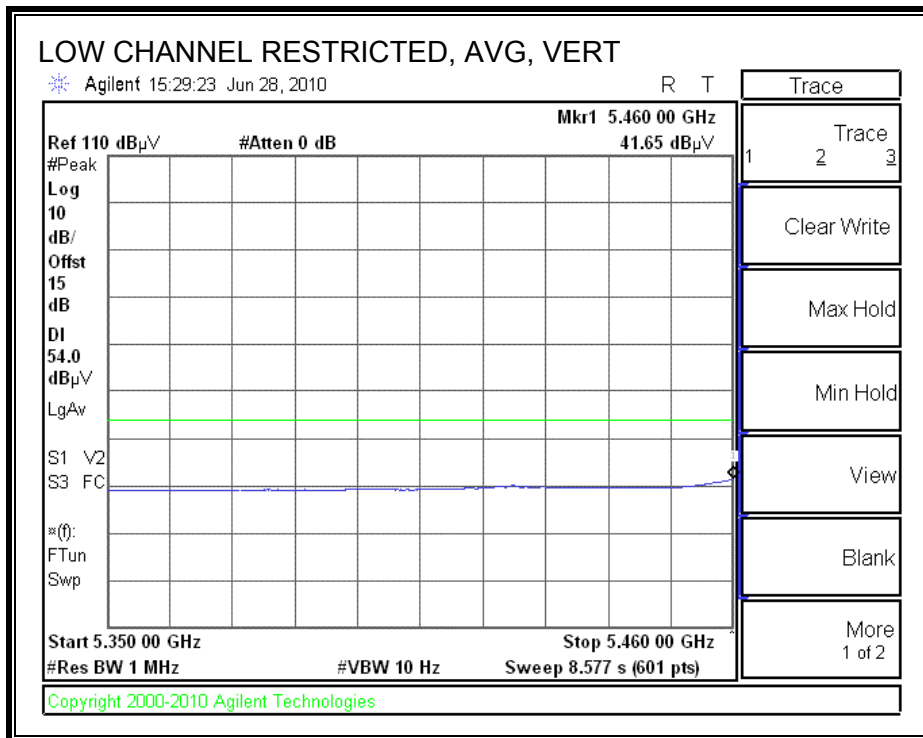
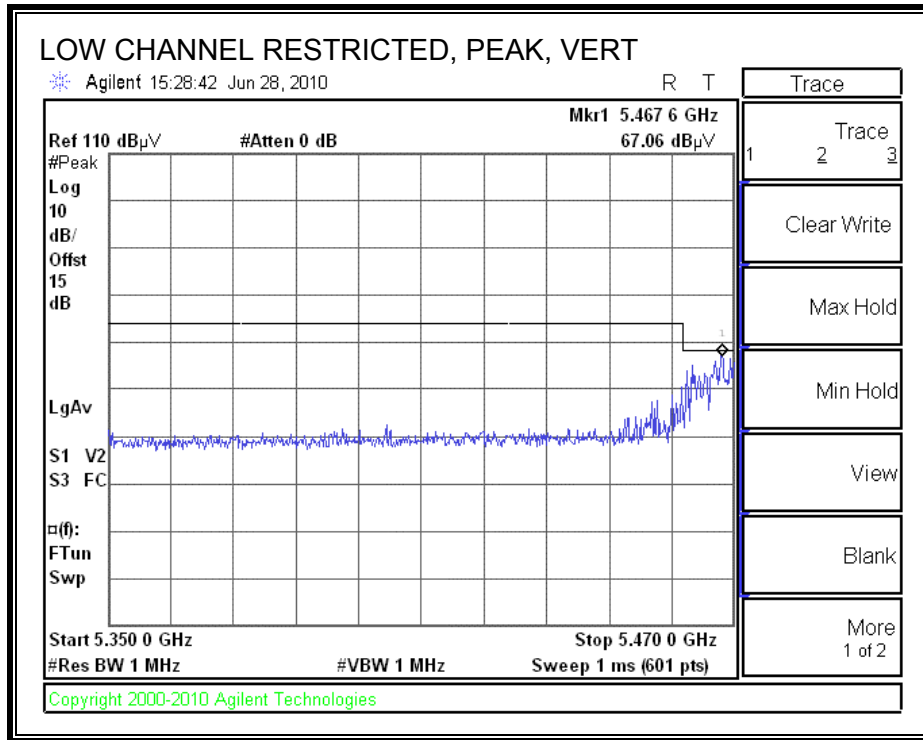

**AUTHORIZED BANDEDGE (HIGH CHANNEL, HORIZONTAL)**

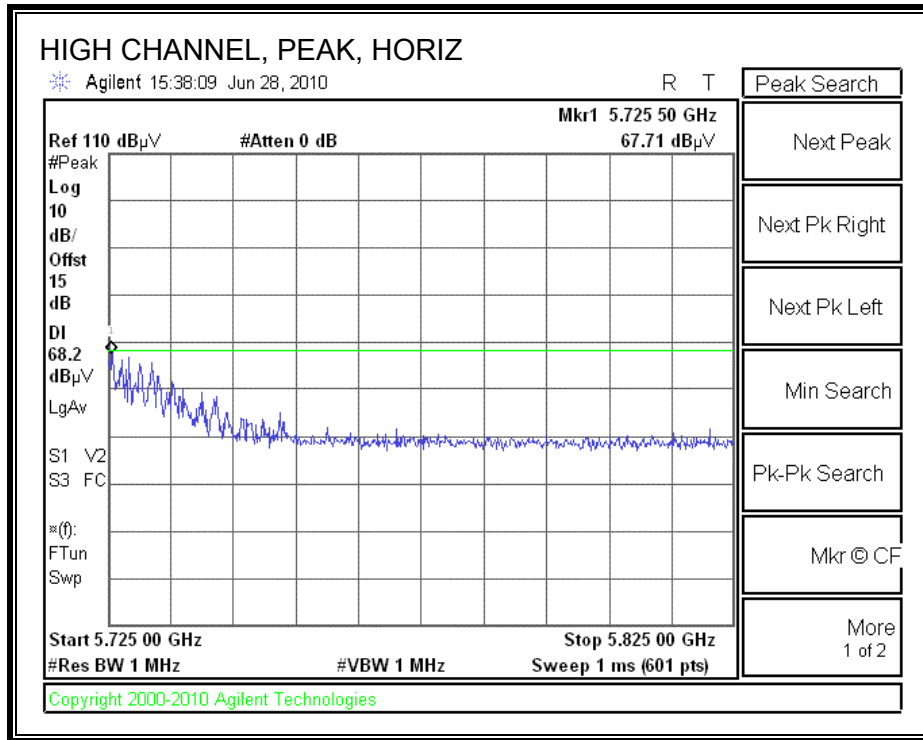

**AUTHORIZED BANDEDGE (HIGH CHANNEL, VERTICAL)**

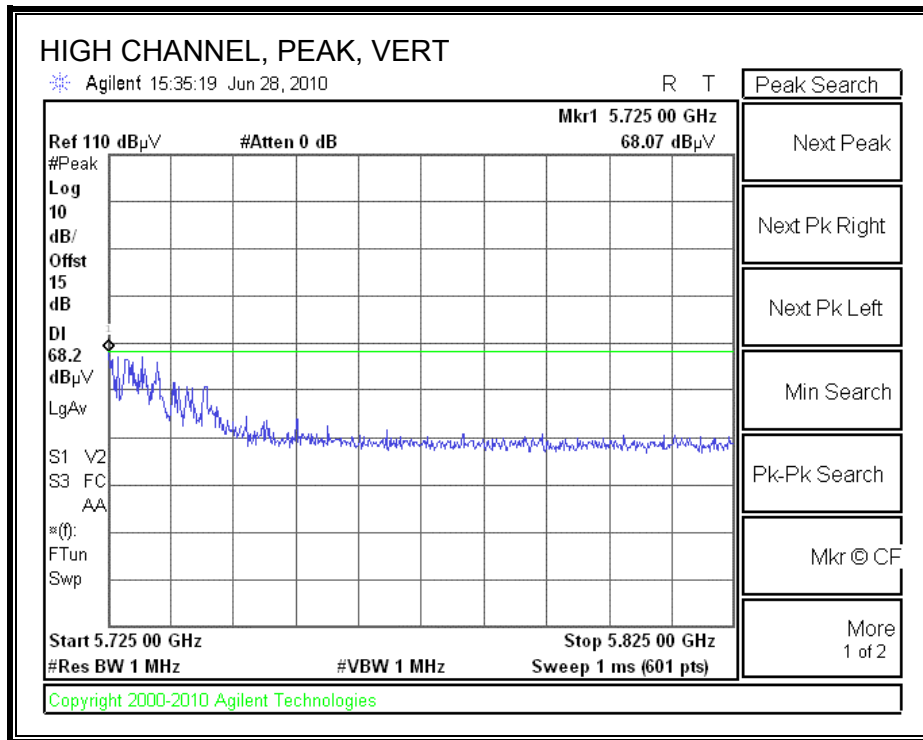

**HARMONICS AND SPURIOUS EMISSIONS**

High Frequency Measurement													
Compliance Certification Services, Fremont 5m Chamber													
Test Engr:		Chin Pang											
Date:		06/29/10											
Project #:		10U13263											
Company:		Broadcom											
EUT Description:		802.11abgn Wlan + bluetooth PCI-E mini card											
EUT M/N:		BCM943224PCIEBT2											
Test Target:		FCC 15.407											
Mode Oper:		TX, 5.6GHz HT20											
f	Measurement Frequency			Amp	Preamp Gain			Average Field Strength Limit					
Dist	Distance to Antenna			D Corr	Distance Correct to 3 meters			Peak Field Strength Limit					
Read	Analyzer Reading			Avg	Average Field Strength @ 3 m			Margin vs. Average Limit					
AF	Antenna Factor			Peak	Calculated Peak Field Strength			Margin vs. Peak Limit					
CL	Cable Loss			HPF	High Pass Filter								
f	Dist	Read	AF	CL	Amp	D Corr	Filtr	Corr.	Limit	Margin	Ant. Pol.	Det.	Notes
GHz	(m)	dBuV	dB/m	dB	dB	dB	dB	dBuV/m	dBuV/m	dB	V/H	P/A/QP	
<b>Low Ch, 5500MHz</b>													
11.000	3.0	41.7	37.6	9.2	-32.6	0.0	0.7	56.7	74.0	-17.3	H	P	
11.000	3.0	28.6	37.6	9.2	-32.6	0.0	0.7	43.5	54.0	-10.5	H	A	
11.000	3.0	40.7	37.6	9.2	-32.6	0.0	0.7	55.6	74.0	-18.4	V	P	
11.000	3.0	28.4	37.6	9.2	-32.6	0.0	0.7	43.4	54.0	-10.6	V	A	
<b>Mid Ch, 5600MHz</b>													
11.200	3.0	43.4	37.8	9.3	-32.6	0.0	0.7	58.6	74.0	-15.4	V	P	
11.200	3.0	30.4	37.8	9.3	-32.6	0.0	0.7	45.6	54.0	-8.4	V	A	
11.200	3.0	43.5	37.8	9.3	-32.6	0.0	0.7	58.8	74.0	-15.2	H	P	
11.200	3.0	30.2	37.8	9.3	-32.6	0.0	0.7	45.5	54.0	-8.5	H	A	
<b>High Ch, 5700MHz</b>													
11.400	3.0	37.8	38.0	9.4	-32.5	0.0	0.7	53.3	74.0	-20.7	H	P	
11.400	3.0	24.7	38.0	9.4	-32.5	0.0	0.7	40.3	54.0	-13.7	H	A	
11.400	3.0	38.6	38.0	9.4	-32.5	0.0	0.7	54.2	74.0	-19.8	V	P	
11.400	3.0	25.9	38.0	9.4	-32.5	0.0	0.7	41.4	54.0	-12.6	V	A	
Rev. 4.1.2.7													
Note: No other emissions were detected above the system noise floor.													

### 8.2.11. 802.11n HT40 SISO MODE IN THE 5.6 GHz BAND

#### RESTRICTED BANDEDGE (LOW CHANNEL, HORIZONTAL)

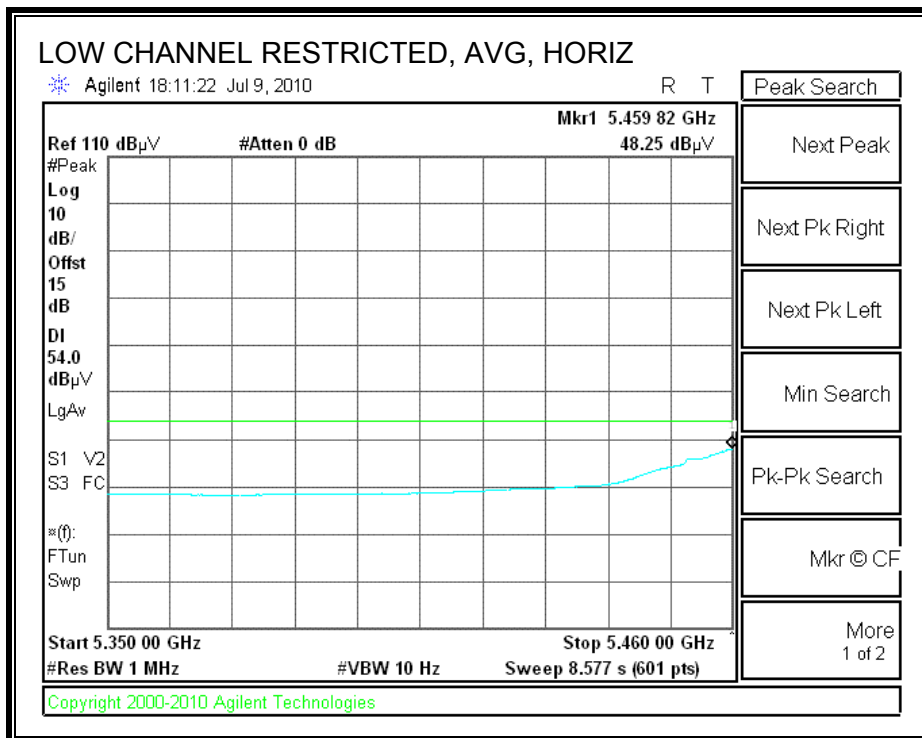
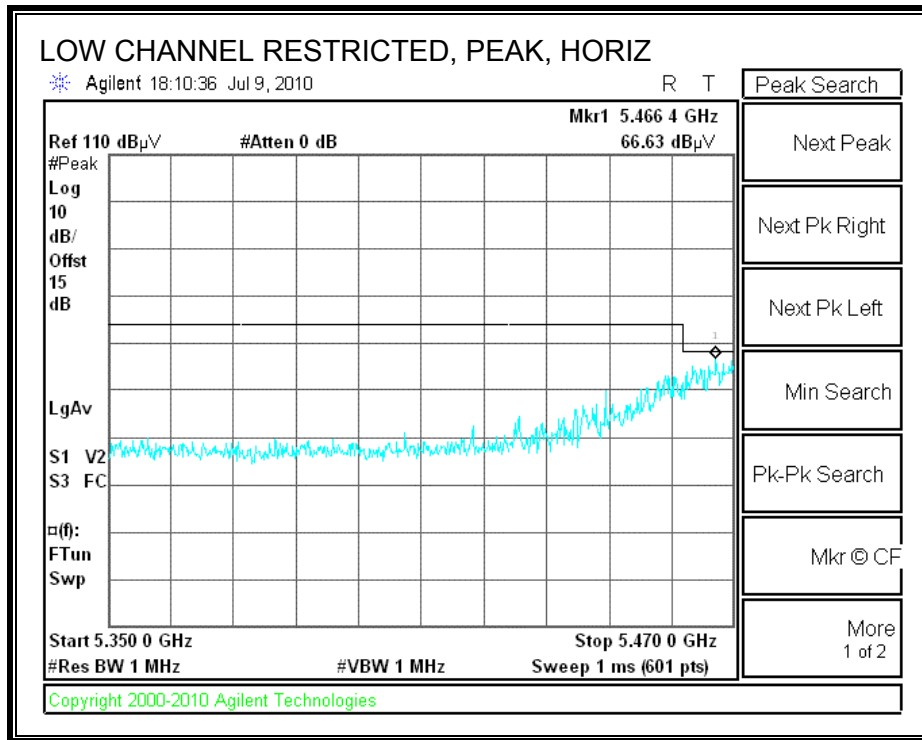

**RESTRICTED BANDEDGE (LOW CHANNEL, VERTICAL)**

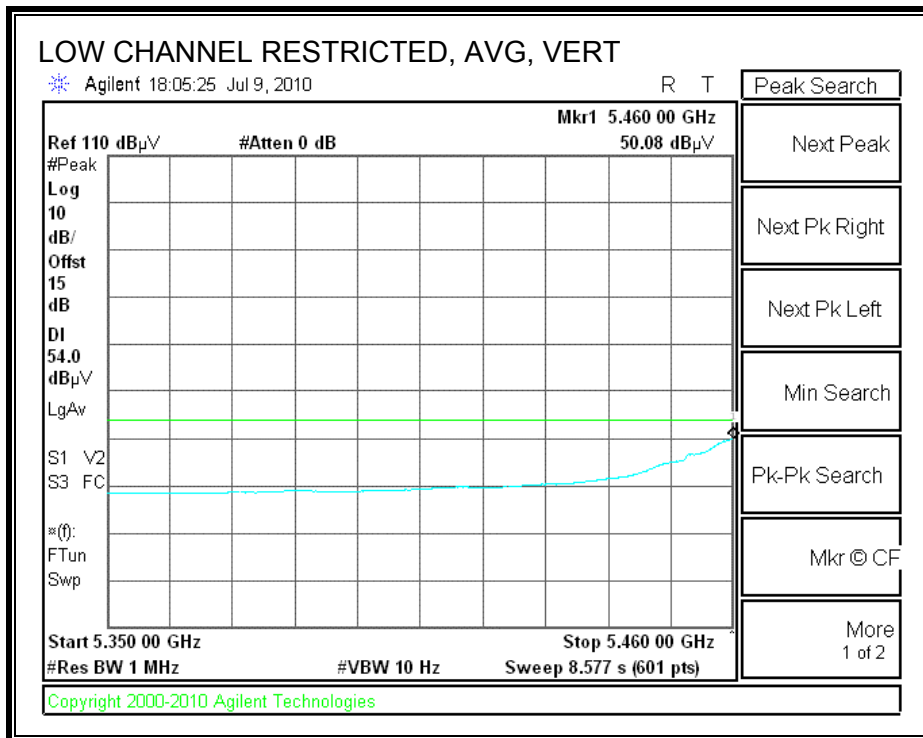
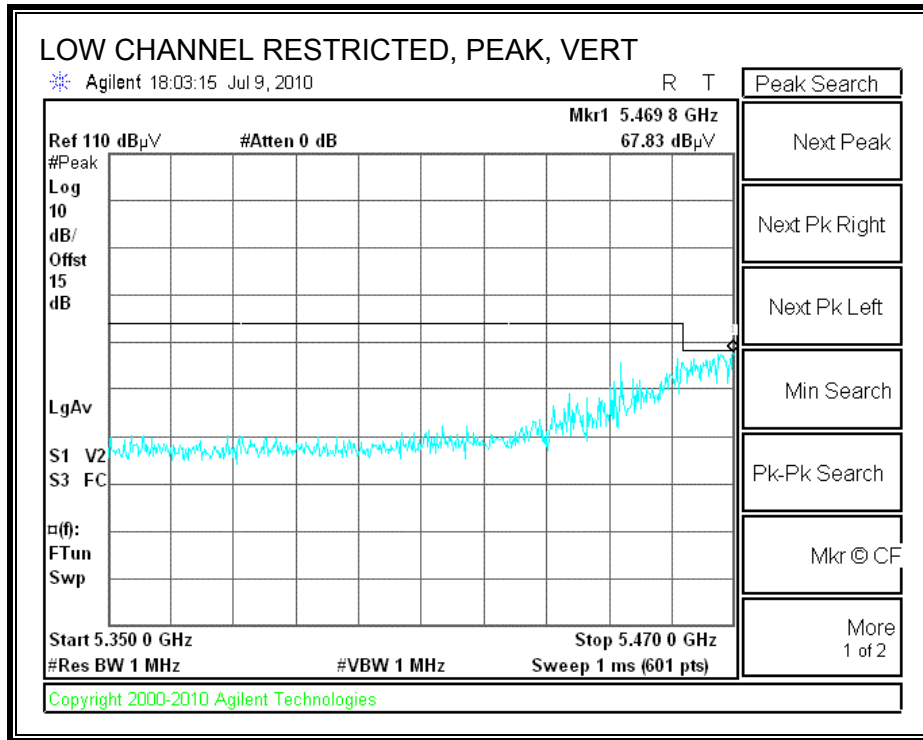

**AUTHORIZED BANDEDGE (HIGH CHANNEL, HORIZONTAL)**

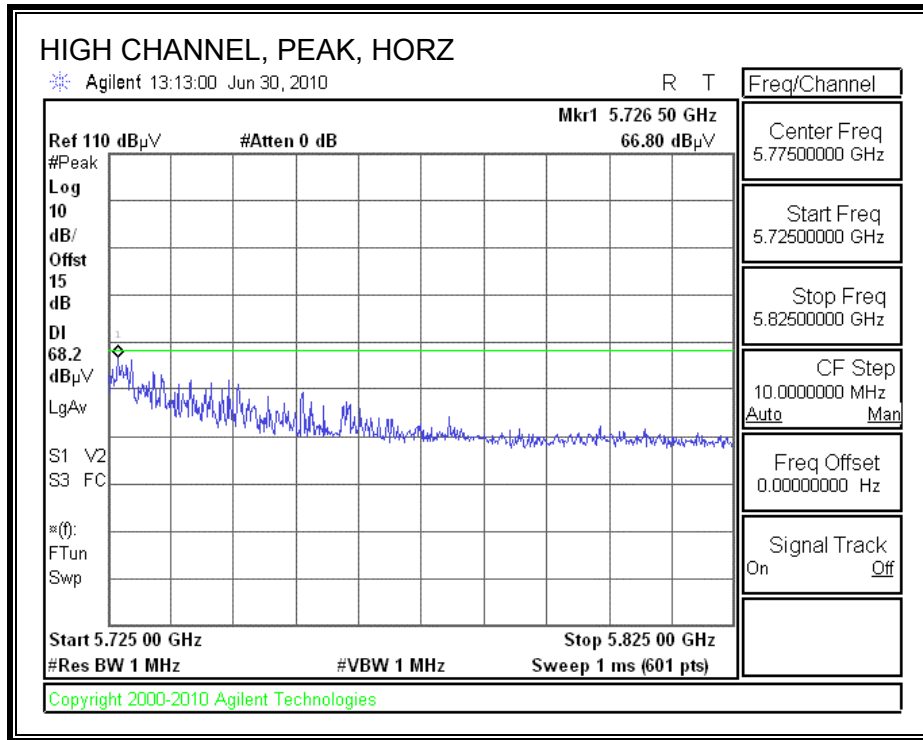

**AUTHORIZED BANDEDGE (HIGH CHANNEL, VERTICAL)**

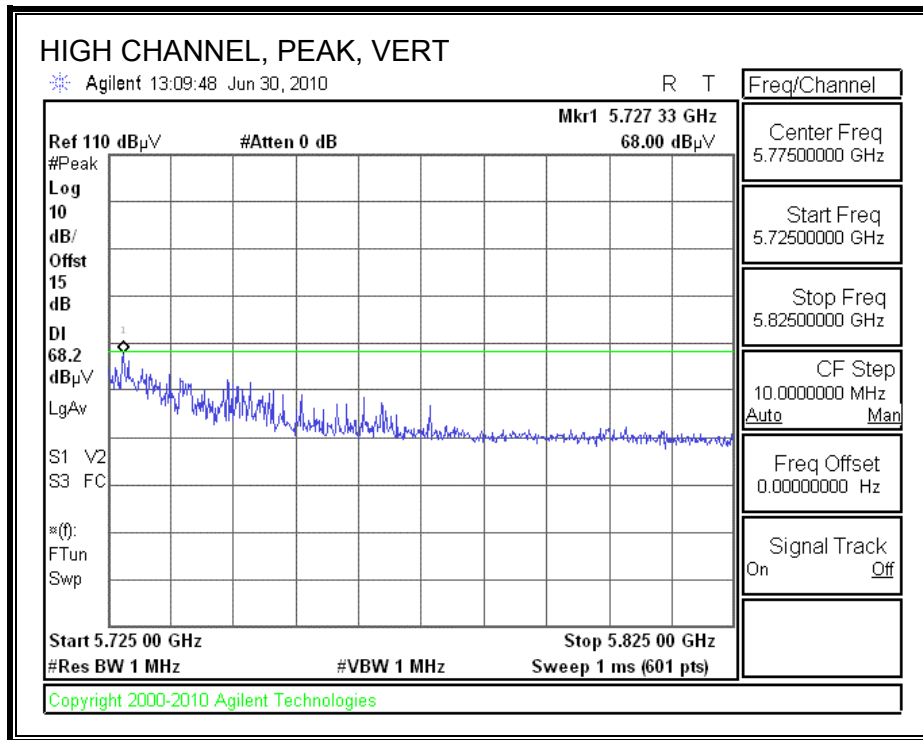



**HARMONICS AND SPURIOUS EMISSIONS**

High Frequency Measurement													
Compliance Certification Services, Fremont 5m Chamber													
Test Engr:		Chin Pang											
Date:		06/29/10											
Project #:		10U13263											
Company:		Broadcom											
EUT Description:		802.11abgn Wlan + bluetooth PCI-E mini card											
EUT M/N:		BCM943224PCIEBT2											
Test Target:		FCC 15.407											
Mode Oper:		TX, 5.6GHz HT40 SISO											
f	Measurement Frequency			Amp	Preamp Gain			Average Field Strength Limit					
Dist	Distance to Antenna			D Corr	Distance Correct to 3 meters			Peak Field Strength Limit					
Read	Analyzer Reading			Avg	Average Field Strength @ 3 m			Margin vs. Average Limit					
AF	Antenna Factor			Peak	Calculated Peak Field Strength			Margin vs. Peak Limit					
CL	Cable Loss			HPF	High Pass Filter								
f	Dist	Read	AF	CL	Amp	D Corr	Filtr	Corr.	Limit	Margin	Ant. Pol.	Det.	Notes
GHz	(m)	dBuV	dB/m	dB	dB	dB	dB	dBuV/m	dBuV/m	dB	V/H	P/A/QP	
<b>Low Ch, 5510MHz</b>													
11.020	3.0	37.7	37.6	9.2	-32.6	0.0	0.7	52.7	74.0	-21.3	V	P	
11.020	3.0	25.2	37.6	9.2	-32.6	0.0	0.7	40.2	54.0	-13.8	V	A	
11.020	3.0	35.6	37.6	9.2	-32.6	0.0	0.7	50.6	74.0	-23.4	H	P	
11.020	3.0	23.2	37.6	9.2	-32.6	0.0	0.7	38.2	54.0	-15.8	H	A	
<b>Mid Ch, 5590MHz</b>													
11.180	3.0	36.5	37.7	9.3	-32.6	0.0	0.7	51.7	74.0	-22.3	H	P	
11.180	3.0	22.9	37.7	9.3	-32.6	0.0	0.7	38.1	54.0	-15.9	H	A	
11.180	3.0	37.4	37.7	9.3	-32.6	0.0	0.7	52.7	74.0	-21.3	V	P	
11.180	3.0	24.9	37.7	9.3	-32.6	0.0	0.7	40.1	54.0	-13.9	V	A	
<b>High Ch, 5670MHz</b>													
11.340	3.0	35.0	37.9	9.4	-32.6	0.0	0.7	50.4	74.0	-23.6	V	P	
11.340	3.0	23.6	37.9	9.4	-32.6	0.0	0.7	39.0	54.0	-15.0	V	A	
11.340	3.0	35.2	37.9	9.4	-32.6	0.0	0.7	50.7	74.0	-23.3	H	P	
11.340	3.0	23.0	37.9	9.4	-32.6	0.0	0.7	38.5	54.0	-15.5	H	A	
Rev. 4.1.2.7													
Note: No other emissions were detected above the system noise floor.													

**8.2.12. 802.11n HT40 MIMO MCS0 MODE IN THE 5.6 GHz BAND**

**RESTRICTED BANDEDGE (LOW CHANNEL, HORIZONTAL)**

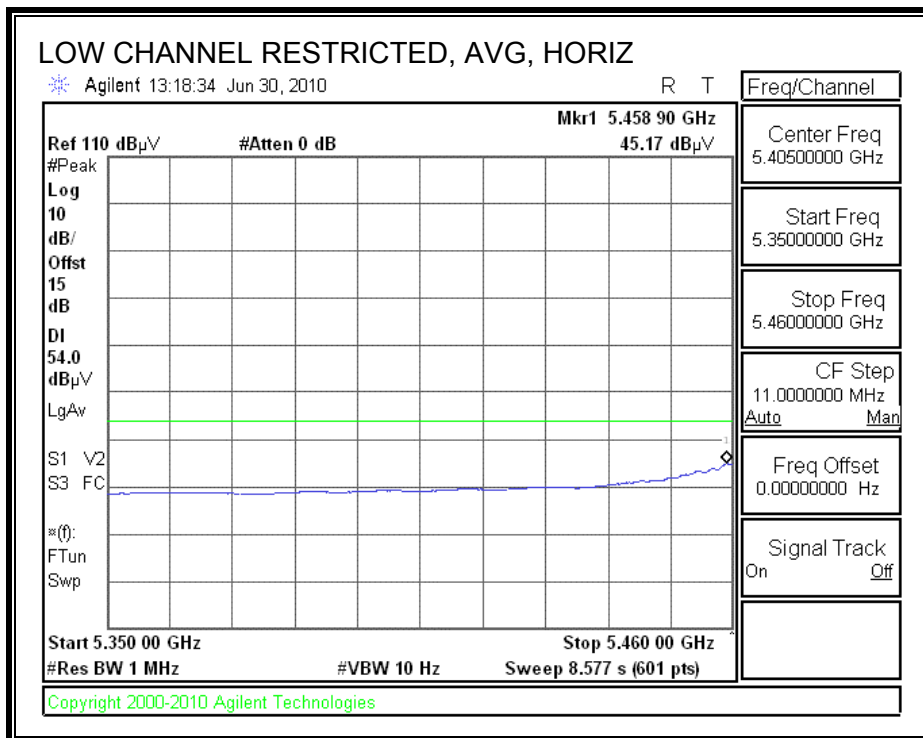
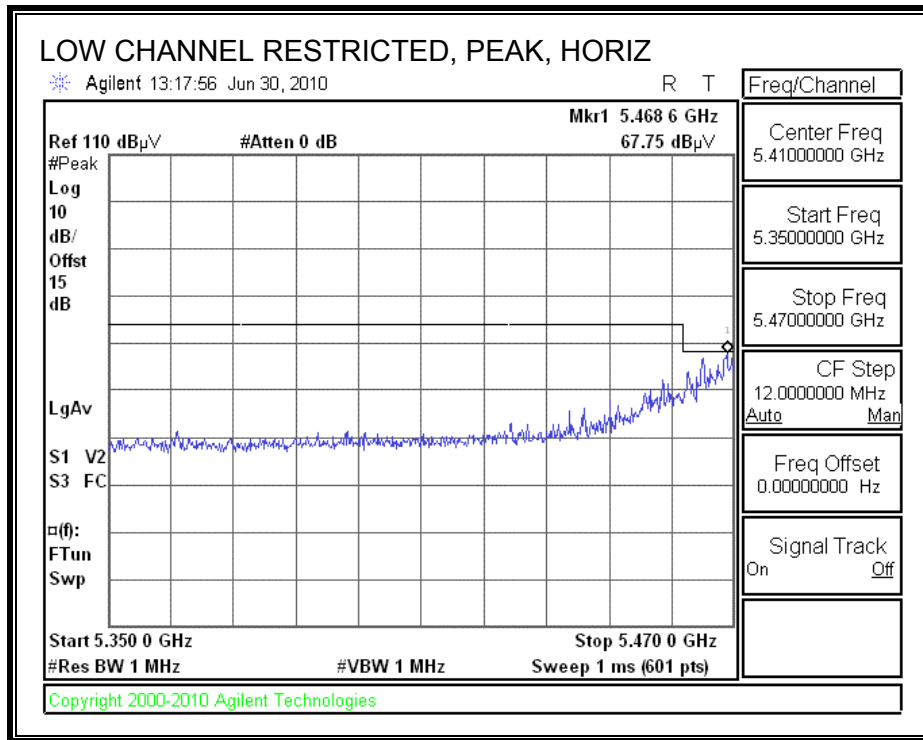

**RESTRICTED BANDEDGE (LOW CHANNEL, VERTICAL)**

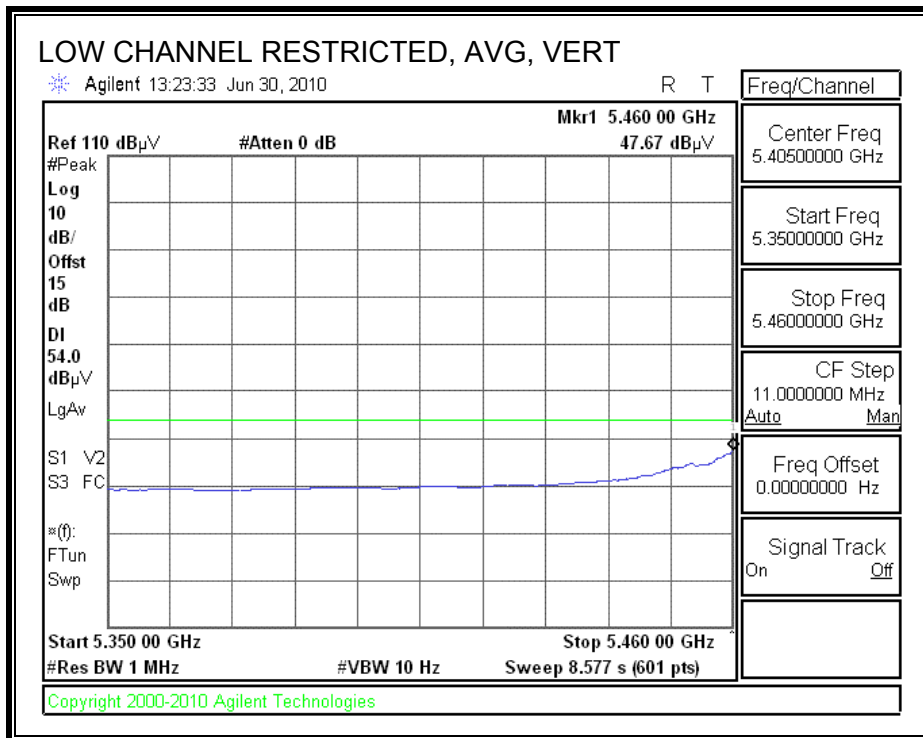
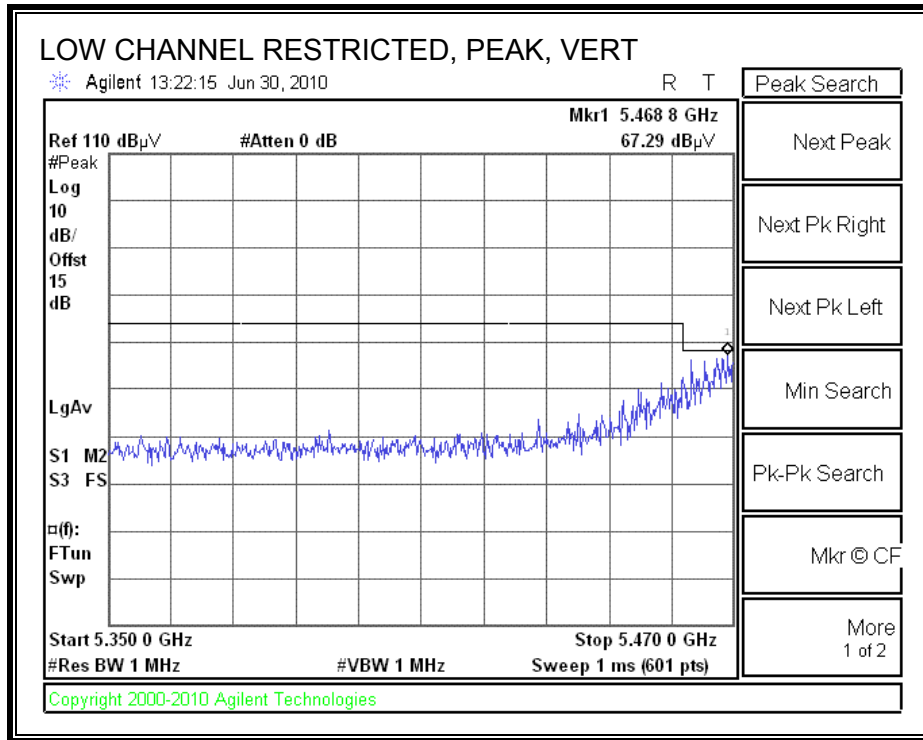

**AUTHORIZED BANDEGE (HIGH CHANNEL, HORIZONTAL)**

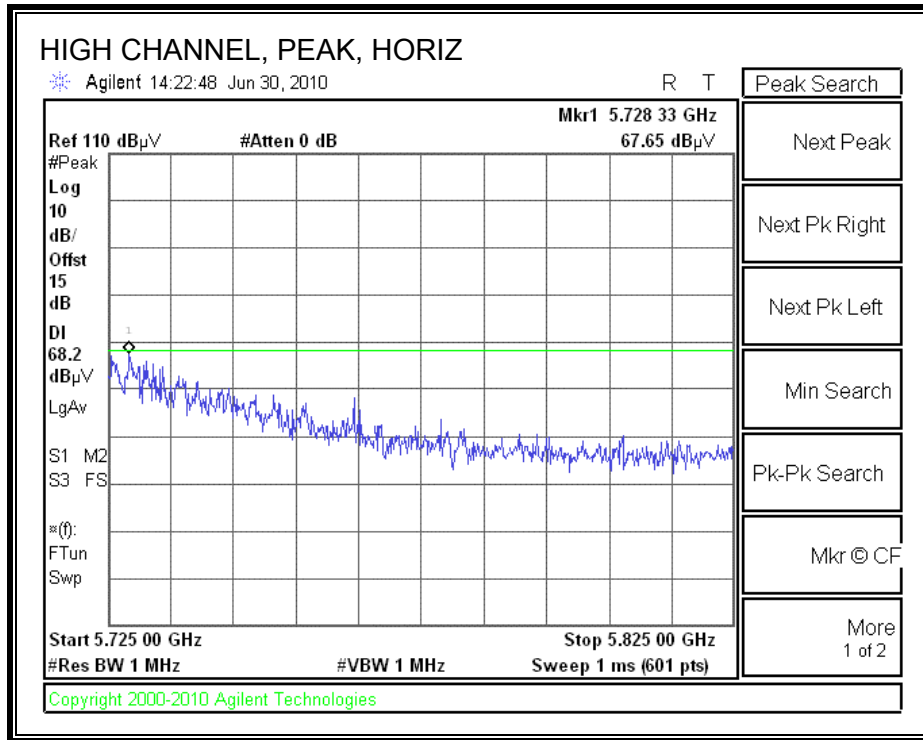

**AUTHORIZED BANDEGE (HIGH CHANNEL, VERTICAL)**

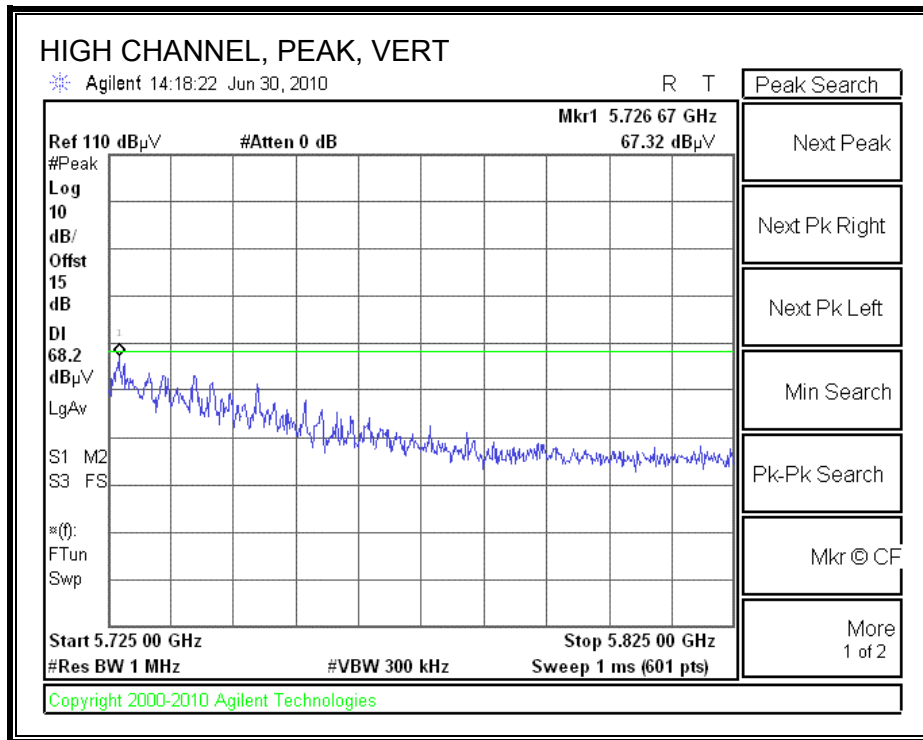

**HARMONICS AND SPURIOUS EMISSIONS**

High Frequency Measurement													
Compliance Certification Services, Fremont 5m Chamber													
Test Engr:		Chin Pang											
Date:		06/29/10											
Project #:		10U13263											
Company:		Broadcom											
EUT Description:		802.11abgn Wlan + bluetooth PCI-E mini card											
EUT M/N:		BCM943224PCIEBT2											
Test Target:		FCC 15.407											
Mode Oper:		TX, 5.6GHz HT40 MIMO											
f	Measurement Frequency			Amp	Preamp Gain			Average Field Strength Limit					
Dist	Distance to Antenna			D Corr	Distance Correct to 3 meters			Peak Field Strength Limit					
Read	Analyzer Reading			Avg	Average Field Strength @ 3 m			Margin vs. Average Limit					
AF	Antenna Factor			Peak	Calculated Peak Field Strength			Margin vs. Peak Limit					
CL	Cable Loss			HPF	High Pass Filter								
f GHz	Dist (m)	Read dBuV	AF dB/m	CL dB	Amp dB	D Corr dB	Filtr dB	Corr. dBuV/m	Limit dBuV/m	Margin dB	Ant. Pol V/H	Det. P/A/QP	Notes
<b>Low Ch, 5510MHz</b>													
11.020	3.0	35.2	37.6	9.2	-32.6	0.0	0.7	50.2	74.0	-23.8	H	P	
11.020	3.0	24.1	37.6	9.2	-32.6	0.0	0.7	39.1	54.0	-14.9	H	A	
11.020	3.0	37.8	37.6	9.2	-32.6	0.0	0.7	52.8	74.0	-21.2	V	P	
11.020	3.0	25.4	37.6	9.2	-32.6	0.0	0.7	40.4	54.0	-13.6	V	A	
<b>Mid Ch, 5590MHz</b>													
11.180	3.0	39.6	37.7	9.3	-32.6	0.0	0.7	54.9	74.0	-19.1	V	P	
11.180	3.0	26.9	37.7	9.3	-32.6	0.0	0.7	42.2	54.0	-11.8	V	A	
11.180	3.0	38.1	37.7	9.3	-32.6	0.0	0.7	53.3	74.0	-20.7	H	P	
11.180	3.0	25.1	37.7	9.3	-32.6	0.0	0.7	40.4	54.0	-13.6	H	A	
<b>High Ch, 5670MHz</b>													
11.340	3.0	35.7	37.9	9.4	-32.6	0.0	0.7	51.2	74.0	-22.8	H	P	
11.340	3.0	24.1	37.9	9.4	-32.6	0.0	0.7	39.6	54.0	-14.4	H	A	
11.340	3.0	38.1	37.9	9.4	-32.6	0.0	0.7	53.5	74.0	-20.5	V	P	
11.340	3.0	25.1	37.9	9.4	-32.6	0.0	0.7	40.5	54.0	-13.5	V	A	
Rev. 4.1.2.7													
Note: No other emissions were detected above the system noise floor.													

### 8.3. RECEIVER ABOVE 1 GHz

#### 8.3.1. FOR 20 MHz BANDWIDTH IN THE 5 GHz BAND

**High Frequency Measurement**  
 Compliance Certification Services, Fremont 3m Chamber

Company: Broadcom  
 Project #: 10U13263  
 Date: 06/24/10  
 Test Engineer: Chin Pang  
 Configuration: EUT / Test JIG / Laptop  
 Mode: Rx Mode\_5GHz Band\_20MHz Bandwidth

**Test Equipment:**

Horn 1-18GHz	Pre-amplifer 1-26GHz	Pre-amplifer 26-40GHz	Horn > 18GHz	Limit
T60; S/N: 2238 @3m	T34 HP 8449B			RX RSS 210

Hi Frequency Cables

3' cable 22807700	12' cable 22807600	20' cable 22807500	HPF	Reject Filter	<u>Peak Measurements</u> RBW=VBW=1MHz <u>Average Measurements</u> RBW=1MHz ; VBW=10Hz
3' cable 22807700	12' cable 22807600	20' cable 22807500			

f GHz	Dist (m)	Read Pk dBuV	Read Avg. dBuV	AF dB/m	CL dB	Amp dB	D Corr dB	Fltr dB	Peak dBuV/m	Avg dBuV/m	Pk Lim dBuV/m	Avg Lim dBuV/m	Pk Mar dB	Avg Mar dB	Notes (V/H)
1.096	3.0	56.5	37.2	24.8	2.5	-38.1	0.0	0.0	45.6	26.3	74	54	-28.4	-27.7	V
1.333	3.0	54.9	50.1	25.6	2.8	-37.8	0.0	0.0	45.4	40.6	74	54	-28.6	-13.4	V
1.498	3.0	54.0	35.2	26.1	2.9	-37.6	0.0	0.0	45.5	26.7	74	54	-28.5	-27.3	V
2.493	3.0	62.0	40.5	28.3	3.9	-36.3	0.0	0.0	58.0	36.5	74	54	-16.0	-17.5	Y
1.098	3.0	52.3	38.0	24.8	2.5	-38.1	0.0	0.0	41.4	27.1	74	54	-32.6	-26.9	H
1.333	3.0	50.0	44.3	25.6	2.8	-37.8	0.0	0.0	40.5	34.8	74	54	-33.5	-19.2	H
1.397	3.0	50.0	36.5	25.8	2.8	-37.7	0.0	0.0	40.9	27.4	74	54	-33.1	-26.6	H
2.490	3.0	57.5	36.3	28.3	3.9	-36.3	0.0	0.0	53.4	32.2	74	54	-20.6	-21.8	H
No other emissions were detected above system noise floor															

f	Measurement Frequency	Amp	Preamp Gain	Avg Lim	Average Field Strength Limit
Dist	Distance to Antenna	D Corr	Distance Correct to 3 meters	Pk Lim	Peak Field Strength Limit
Read	Analyzer Reading	Avg	Average Field Strength @ 3 m	Avg Mar	Margin vs. Average Limit
AF	Antenna Factor	Peak	Calculated Peak Field Strength	Pk Mar	Margin vs. Peak Limit
CL	Cable Loss	HPF	High Pass Filter		

### 8.3.2. FOR 40 MHz BANDWIDTH IN THE 5 GHz BAND

**High Frequency Measurement**  
 Compliance Certification Services, Fremont 3m Chamber

Company: Broadcom  
 Project #: 10U13263  
 Date: 06/24/10  
 Test Engineer: Chin Pang  
 Configuration: EUT / Test JIG / Laptop  
 Mode: Rx Mode\_5 GHz Band\_40MHz Bandwidth

**Test Equipment:**

Horn 1-18GHz	Pre-amplifier 1-26GHz	Pre-amplifier 26-40GHz	Horn > 18GHz	Limit
T60; S/N: 2238 @3m	T34 HP 8449B			RX RSS 210

Hi Frequency Cables

3' cable 22807700	12' cable 22807600	20' cable 22807500	HPF	Reject Filter	
3' cable 22807700	12' cable 22807600	20' cable 22807500			<u>Peak Measurements</u> RBW=VBW=1MHz <u>Average Measurements</u> RBW=1MHz ; VBW=10Hz

f GHz	Dist (m)	Read Pk dBuV	Read Avg. dBuV	AF dB/m	CL dB	Amp dB	D Corr dB	Fltr dB	Peak dBuV/m	Avg dBuV/m	Pk Lim dBuV/m	Avg Lim dBuV/m	Pk Mar dB	Avg Mar dB	Notes (V/H)
1.333	3.0	56.0	51.2	25.6	2.8	-37.8	0.0	0.0	46.6	41.8	74	54	-27.4	-12.2	V
1.498	3.0	55.1	36.3	26.1	2.9	-37.6	0.0	0.0	46.6	27.8	74	54	-27.4	-26.2	V
2.493	3.0	63.1	41.6	28.3	3.9	-36.3	0.0	0.0	59.1	37.6	74	54	-14.9	-16.4	V
1.098	3.0	53.4	39.1	24.8	2.5	-38.1	0.0	0.0	42.6	28.3	74	54	-31.4	-25.7	H
1.333	3.0	51.1	45.4	25.6	2.8	-37.8	0.0	0.0	41.7	36.0	74	54	-32.3	-18.0	H
2.490	3.0	58.6	37.4	28.3	3.9	-36.3	0.0	0.0	54.6	33.4	74	54	-19.4	-20.6	H
No other emissions were detected above system noise floor															

f	Measurement Frequency	Amp	Preamp Gain	Avg Lim	Average Field Strength Limit
Dist	Distance to Antenna	D Corr	Distance Correct to 3 meters	Pk Lim	Peak Field Strength Limit
Read	Analyzer Reading	Avg	Average Field Strength @ 3 m	Avg Mar	Margin vs. Average Limit
AF	Antenna Factor	Peak	Calculated Peak Field Strength	Pk Mar	Margin vs. Peak Limit
CL	Cable Loss	HPF	High Pass Filter		

### 8.4. WORST-CASE BELOW 1 GHz

#### SPURIOUS EMISSIONS 30 TO 1000 MHz (WORST-CASE CONFIGURATION)

30-1000MHz Frequency Measurement													
Compliance Certification Services, Fremont 5m Chamber													
Test Engr:		Chin Pang											
Date:		06/21/10											
Project #:		10U13263											
Company:		Broadcom											
EUT Description:		EU 802.11abgn Wlan + Bluetooth PCI-E mini card											
EUT M/N:		BCM943224PCIEBT2											
Test Target:		FCC 15B											
Mode Oper:		TX, 5GHz Band - Worst-Case											
f	Measurement Frequency	Amp	Preamp Gain	Margin	Margin vs. Limit								
Dist	Distance to Antenna	D Corr	Distance Correct to 3 meters										
Read	Analyzer Reading	Filter	Filter Insert Loss										
AF	Antenna Factor	Corr.	Calculated Field Strength										
CL	Cable Loss	Limit	Field Strength Limit										
f	Dist	Read	AF	CL	Amp	D Corr	Filter	Corr.	Limit	Margin	Ant. Pol.	Det.	Notes
MHz	(m)	dBuV	dB/m	dB	dB	dB	dB	dBuV/m	dBuV/m	dB	V/H	P/A/QP	
79.322	3.0	56.1	7.4	0.8	28.3	0.0	0.0	35.9	40.0	-4.1	H	P	
144.005	3.0	50.7	13.0	1.1	28.3	0.0	0.0	36.5	43.5	-7.0	H	P	
230.528	3.0	54.6	11.9	1.3	28.2	0.0	0.0	39.6	46.0	-6.4	H	P	
336.013	3.0	52.5	14.0	1.6	28.1	0.0	0.0	40.0	46.0	-6.0	H	P	
231.128	3.0	49.4	11.9	1.3	28.2	0.0	0.0	34.4	46.0	-11.6	V	P	
322.812	3.0	52.2	13.8	1.6	28.1	0.0	0.0	39.5	46.0	-6.5	V	P	
368.894	3.0	50.9	14.5	1.7	28.1	0.0	0.0	39.0	46.0	-7.0	V	P	
598.943	3.0	43.5	18.4	2.2	27.5	0.0	0.0	36.6	46.0	-9.4	V	P	
Rev. 1.27.09													
Note: No other emissions were detected above the system noise floor.													



## 9. AC POWER LINE CONDUCTED EMISSIONS

### LIMITS

FCC §15.207 (a)

RSS-Gen 7.2.2

Frequency of Emission (MHz)	Conducted Limit (dBuV)	
	Quasi-peak	Average
0.15-0.5	66 to 56*	56 to 46*
0.5-5	56	46
5-30	60	50

\* Decreases with the logarithm of the frequency.

### TEST PROCEDURE

ANSI C63.4

### RESULTS

**6 WORST EMISSIONS**

CONDUCTED EMISSIONS DATA (115VAC 60Hz)									
Freq.	Reading			Closs	Limit	EN_B	Margin		Remark
(MHz)	PK (dBuV)	QP (dBuV)	AV (dBuV)	(dB)	QP	AV	QP (dB)	AV (dB)	L1 / L2
0.19	51.05	--	37.36	0.00	63.91	53.91	-12.86	-16.55	L1
0.59	34.32	--	28.94	0.00	56.00	46.00	-21.68	-17.06	L1
1.08	32.32	--	26.47	0.00	56.00	46.00	-23.68	-19.53	L1
0.19	50.20	--	36.96	0.00	63.91	53.91	-13.71	-16.95	L2
0.59	35.53	--	29.21	0.00	56.00	46.00	-20.47	-16.79	L2
1.08	31.72	--	27.06	0.00	56.00	46.00	-24.28	-18.94	L2
6 Worst Data									

**LINE 1 RESULTS**

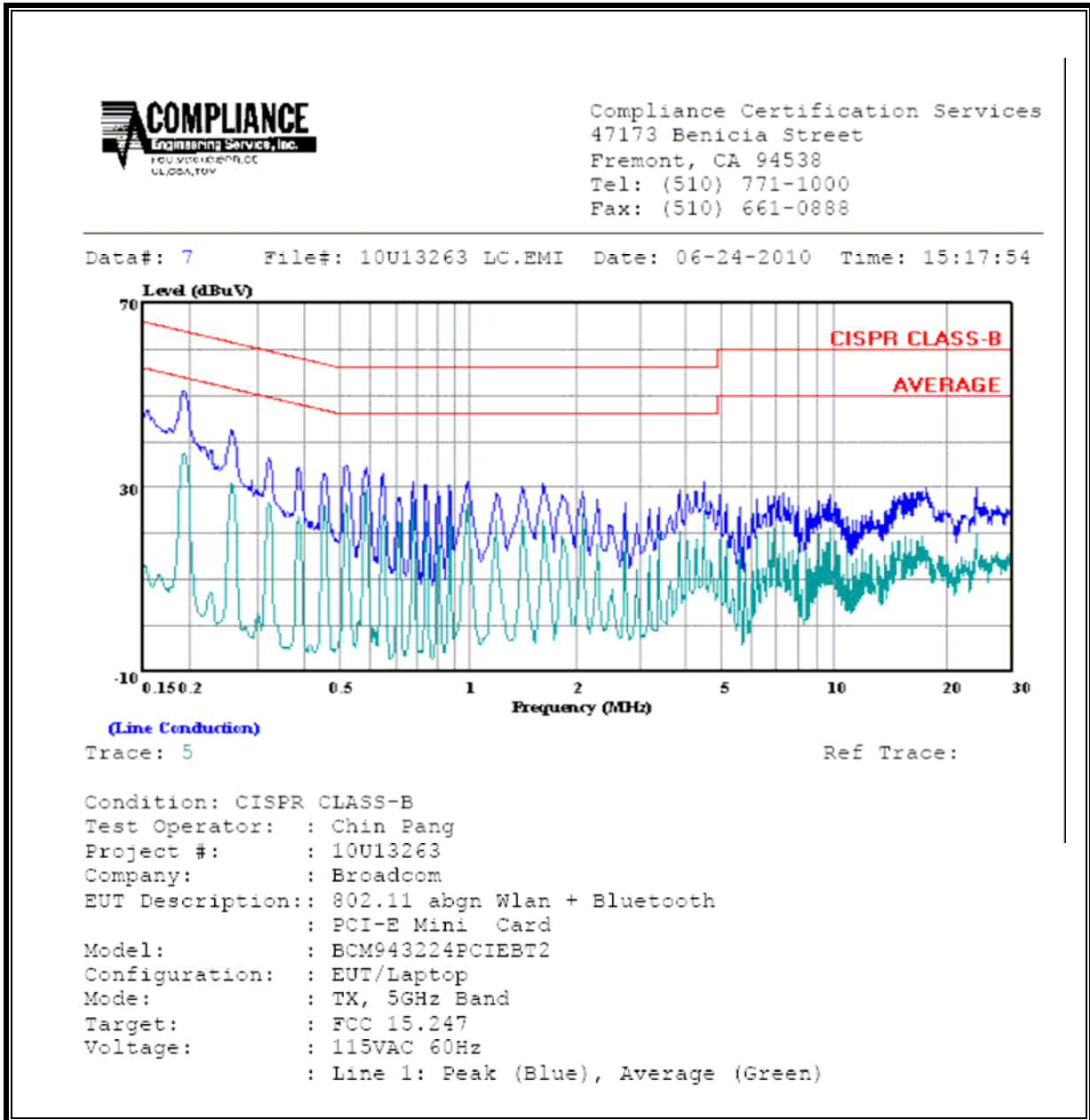

**LINE 2 RESULTS**



Compliance Certification Services  
47173 Benicia Street  
Fremont, CA 94538  
Tel: (510) 771-1000  
Fax: (510) 661-0888

Data#: 14 File#: 10U13263 LC.EMI Date: 06-24-2010 Time: 15:51:06

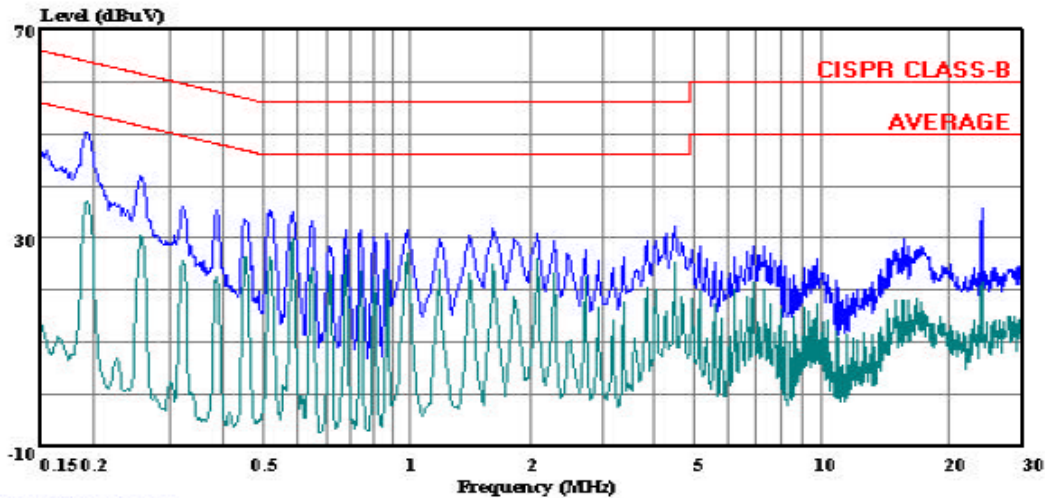

(Line Conduction)

Trace: 12

Ref Trace:

Condition: CISPR CLASS-B  
Test Operator: : Chin Pang  
Project #: : 10U13263  
Company: : Broadcom  
EUT Description: : 802.11 abgn Wlan + Bluetooth  
                  : PCI-E Mini Card  
Model: : BCM943224PCIEBT2  
Configuration: : EUT/Laptop  
Mode: : TX, 5GHz Band  
Target: : FCC 15.247  
Voltage: : 115VAC 60Hz  
          : Line 2: Peak (Blue), Average (Green)

## 10. DYNAMIC FREQUENCY SELECTION

### 10.1. OVERVIEW

#### 10.1.1. LIMITS

##### INDUSTRY CANADA

IC RSS-210 is closely harmonized with FCC Part 15 DFS rules. The deviations are as follows:

RSS-210 Issue 7 A9.4 (b) (ii) **Channel Availability Check Time:** ...

**Additional requirements for the band 5600-5650 MHz:** Until further notice, devices subject to this Section shall not be capable of transmitting in the band 5600-5650 MHz, so that Environment Canada weather radars operating in this band are protected.

RSS-210 Issue 7 A9.4 (b) (iv) **Channel closing time:** the maximum channel closing time is 260 ms.

##### FCC

§15.407 (h) and FCC 06-96 APPENDIX "COMPLIANCE MEASUREMENT PROCEDURES FOR UNLICENSED-NATIONAL INFORMATION INFRASTRUCTURE DEVCIES OPERATING IN THE 5250-5350 MHz AND 5470-5725 MHz BANDS INCORPORATING DYNAMIC FREQUENCY SELECTION".

**Table 1: Applicability of DFS requirements prior to use of a channel**

Requirement	Operational Mode		
	Master	Client (without radar detection)	Client (with radar detection)
Non-Occupancy Period	Yes	Not required	Yes
DFS Detection Threshold	Yes	Not required	Yes
Channel Availability Check Time	Yes	Not required	Not required
Uniform Spreading	Yes	Not required	Not required

**Table 2: Applicability of DFS requirements during normal operation**

Requirement	Operational Mode		
	Master	Client (without DFS)	Client (with DFS)
DFS Detection Threshold	Yes	Not required	Yes
Channel Closing Transmission Time	Yes	Yes	Yes
Channel Move Time	Yes	Yes	Yes

**Table 3: Interference Threshold values, Master or Client incorporating In-Service Monitoring**

Maximum Transmit Power	Value (see note)
≥ 200 milliwatt	-64 dBm
< 200 milliwatt	-62 dBm

Note 1: This is the level at the input of the receiver assuming a 0 dBi receive antenna  
 Note 2: Throughout these test procedures an additional 1 dB has been added to the amplitude of the test transmission waveforms to account for variations in measurement equipment. This will ensure that the test signal is at or above the detection threshold level to trigger a DFS response.

**Table 4: DFS Response requirement values**

Parameter	Value
<i>Non-occupancy period</i>	30 minutes
<i>Channel Availability Check Time</i>	60 seconds
<i>Channel Move Time</i>	10 seconds
<i>Channel Closing Transmission Time</i>	200 milliseconds + approx. 60 milliseconds over remaining 10 second period

The instant that the *Channel Move Time* and the *Channel Closing Transmission Time* begins is as follows:  
 For the Short pulse radar Test Signals this instant is the end of the *Burst*.  
 For the Frequency Hopping radar Test Signal, this instant is the end of the last radar burst generated.  
 For the Long Pulse radar Test Signal this instant is the end of the 12 second period defining the radar transmission.  
 The Channel Closing Transmission Time is comprised of 200 milliseconds starting at the beginning of the Channel Move Time plus any additional intermittent control signals required to facilitate channel changes (an aggregate of approximately 60 milliseconds) during the remainder of the 10 second period. The aggregate duration of control signals will not count quiet periods in between transmissions.

**Table 5 – Short Pulse Radar Test Waveforms**

Radar Type	Pulse Width (Microseconds)	PRI (Microseconds)	Pulses	Minimum Percentage of Successful Detection	Minimum Trials
1	1	1428	18	60%	30
2	1-5	150-230	23-29	60%	30
3	6-10	200-500	16-18	60%	30
4	11-20	200-500	12-16	60%	30
Aggregate (Radar Types 1-4)				80%	120

**Table 6 – Long Pulse Radar Test Signal**

Radar Waveform	Bursts	Pulses per Burst	Pulse Width (µsec)	Chirp Width (MHz)	PRI (µsec)	Minimum Percentage of Successful Detection	Minimum Trials
5	8-20	1-3	50-100	5-20	1000-2000	80%	30

**Table 7 – Frequency Hopping Radar Test Signal**

Radar Waveform	Pulse Width (µsec)	PRI (µsec)	Burst Length (ms)	Pulses per Hop	Hopping Rate (kHz)	Minimum Percentage of Successful Detection	Minimum Trials
6	1	333	300	9	.333	70%	30

### 10.1.2. TEST AND MEASUREMENT SYSTEM

#### RADIATED METHOD SYSTEM BLOCK DIAGRAM

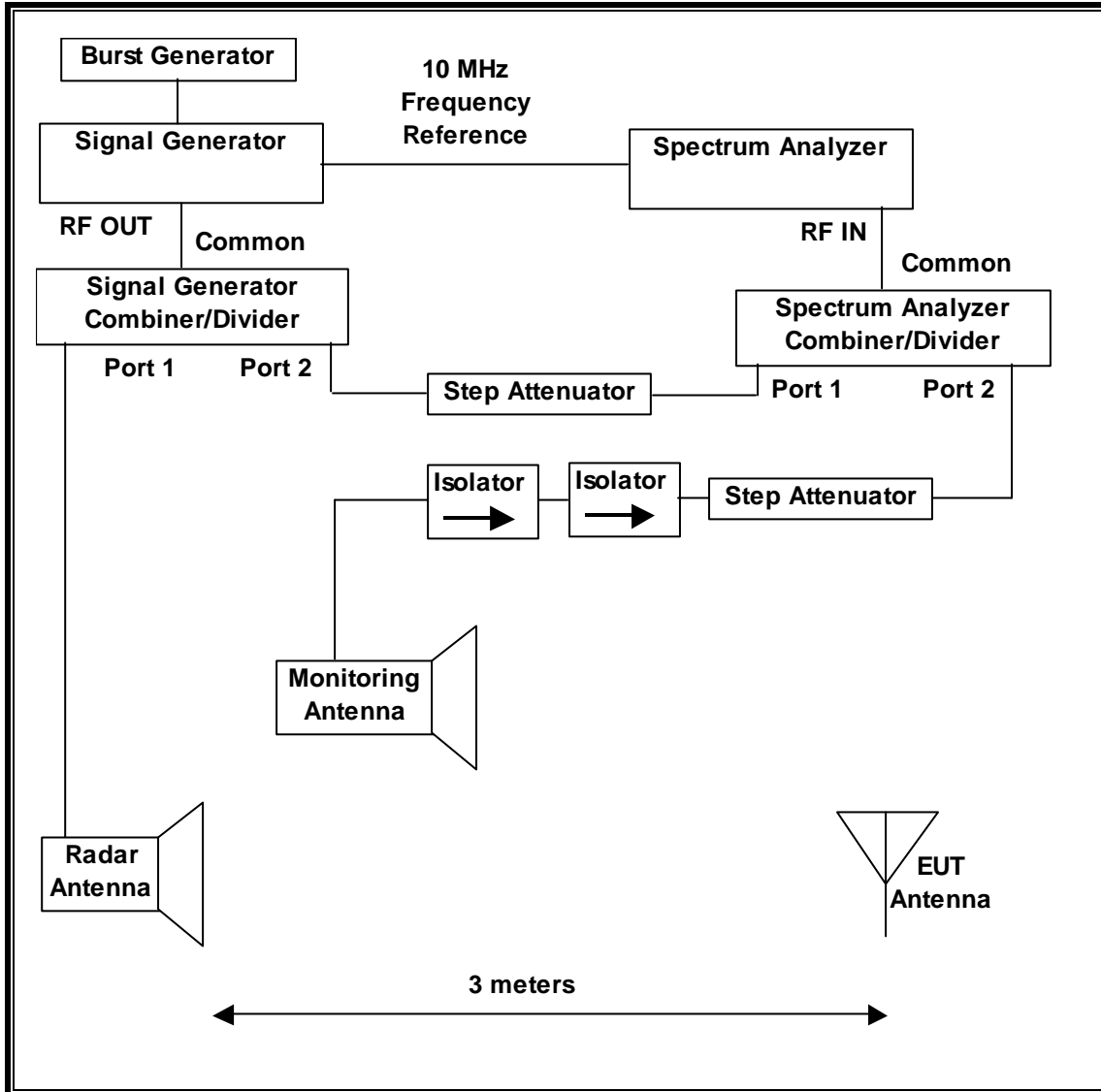



## **SYSTEM OVERVIEW**

The short pulse type 1 radar burst is generated with an arbitrary waveform generator connected to the pulse modulation input of an RF signal generator.

The signal monitoring equipment consists of a spectrum analyzer. The aggregate ON time is calculated by multiplying the number of bins above a threshold during a particular observation period by the dwell time per bin, with the analyzer set to peak detection and max hold.

## **SYSTEM CALIBRATION**

A 50-ohm load is connected in place of the spectrum analyzer, and the spectrum analyzer is connected to a horn antenna via a coaxial cable, with the reference level offset set to (horn antenna gain – coaxial cable loss). The signal generator is set to CW mode. The amplitude of the signal generator is adjusted to yield a level of –64 dBm as measured on the spectrum analyzer.

Without changing any of the instrument settings, the spectrum analyzer is reconnected to the Common port of the Spectrum Analyzer Combiner/Divider. The Reference Level Offset of the spectrum analyzer is adjusted so that the displayed amplitude of the signal is –64 dBm.

The spectrum analyzer displays the level of the signal generator as received at the antenna ports of the Master Device. The interference detection threshold may be varied from the calibrated value of –64 dBm and the spectrum analyzer will still indicate the level as received by the Master Device.

## **ADJUSTMENT OF DISPLAYED TRAFFIC LEVEL**

A link is established between the Master and Slave and the distance between the units is adjusted as needed to provide a suitable received level at the Master and Slave devices. The video test file is streamed to generate WLAN traffic. The monitoring antenna is adjusted so that the WLAN traffic level, as displayed on the spectrum analyzer, is at lower amplitude than the radar detection threshold.

## **TEST AND MEASUREMENT EQUIPMENT**

The following test and measurement equipment was utilized for the DFS tests documented in this report:

<b>TEST EQUIPMENT LIST</b>				
<b>Description</b>	<b>Manufacturer</b>	<b>Model</b>	<b>Serial Number</b>	<b>Cal Due</b>
Spectrum Analyzer, 44 GHz	Agilent / HP	E4446A	C01012	9/3/2011
Signal Generator, 20 GHz	Agilent / HP	83732B	C00774	7/14/2012
Arbitrary Waveform Generator	Agilent / HP	33220A	C01168	10/17/2010

**10.1.3. SETUP OF EUT**

**RADIATED METHOD EUT TEST SETUP**

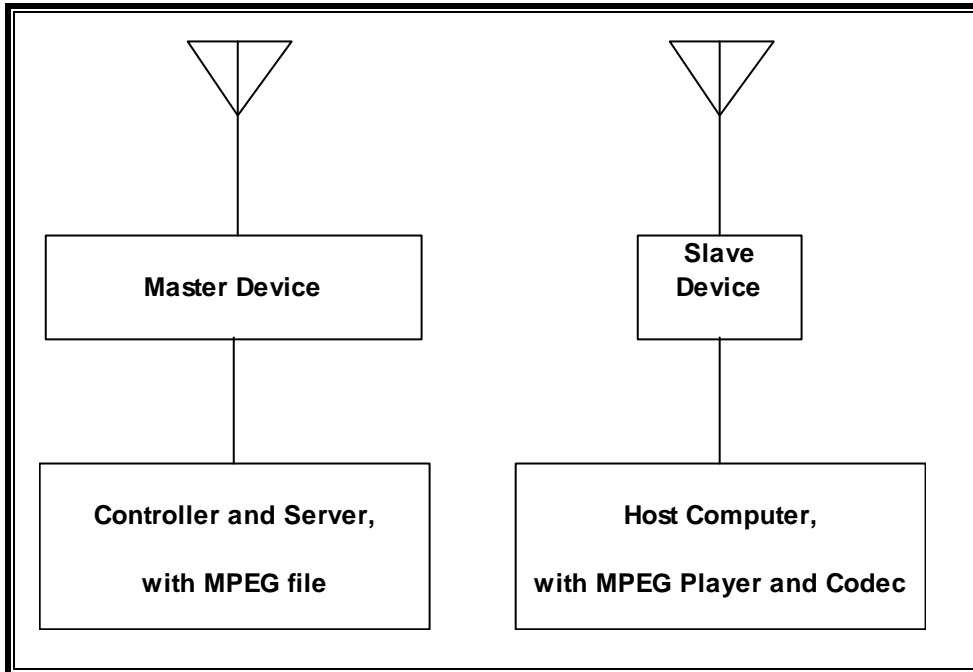

**SUPPORT EQUIPMENT**

The following support equipment was utilized for the DFS tests documented in this report:

PERIPHERAL SUPPORT EQUIPMENT LIST			
Description	Manufacturer	Model	Serial Number
Laptop	Lenovo	4446-38U	R8-CAC5609/08
AC Adapter	Lenovo	ADP-65YB B	11S42T4458Z1ZF4K96V9S9
AC Adapter	HP	Pavillion zv6000	CDN5290451
Laptop	HP	PPP017L	58B240ALLRK0HU
AC Adapter	Linkys	LS12V2A	1196723
Acess Point	Linkys	WRT600N	MNR007800466

#### **10.1.4. DESCRIPTION OF EUT**

The EUT operates over the 5250-5350 MHz and 5470-5725 MHz ranges.

The EUT is a Slave Device without Radar Detection.

The highest power level within these bands is 29.19 dBm EIRP.

The highest gain antenna assembly utilized with the EUT has a gain of 8.86 dBi in the 5250-5350 MHz band and 9.22 dBi in the 5470-5725 MHz band. The lowest gain antenna assembly utilized with the EUT has a gain of 5.55 dBi in the 5250-5350 MHz band and 5.27 dBi in the 5470-5725 MHz band.

The EUT uses two transmitter/receiver chains each connected to an antenna to perform radiated tests.

WLAN traffic is generated by streaming the video file TestFile.mp2 "6 ½ Magic Hours" from the Master to the Slave in full motion video mode using the media player with the V2.61 Codec package.

TPC is required since the maximum EIRP is greater than 500 mW (27 dBm).

The EUT utilizes the 802.11a/n architecture. Two nominal channel bandwidths are implemented: 20 MHz and 40 MHz.

The EUT driver software installed during testing was Broadcom, rev. 5.10.131.31.

#### **MANUFACTURER'S STATEMENT REGARDING UNIFORM CHANNEL SPREADING**

Not Applicable for Slave Devices.

#### **OVERVIEW OF MASTER DEVICE WITH RESPECT TO §15.407 (h) REQUIREMENTS**

The Master Device is a Linux Access Point, FCC ID: Q87-WRT600NV11. The DFS software installed in the Master Device is Linux revision 4.101.27. The minimum antenna gain for the Master Device is 1.6 dBi.

The calibrated radiated DFS Detection Threshold level is set to -64 dBm.

## 10.2. RESULTS FOR 20 MHz BANDWIDTH

### 10.2.1. TEST CHANNEL

All tests were performed at a channel center frequency of 5500 MHz.

### 10.2.2. RADAR WAVEFORM AND TRAFFIC

#### RADAR WAVEFORM

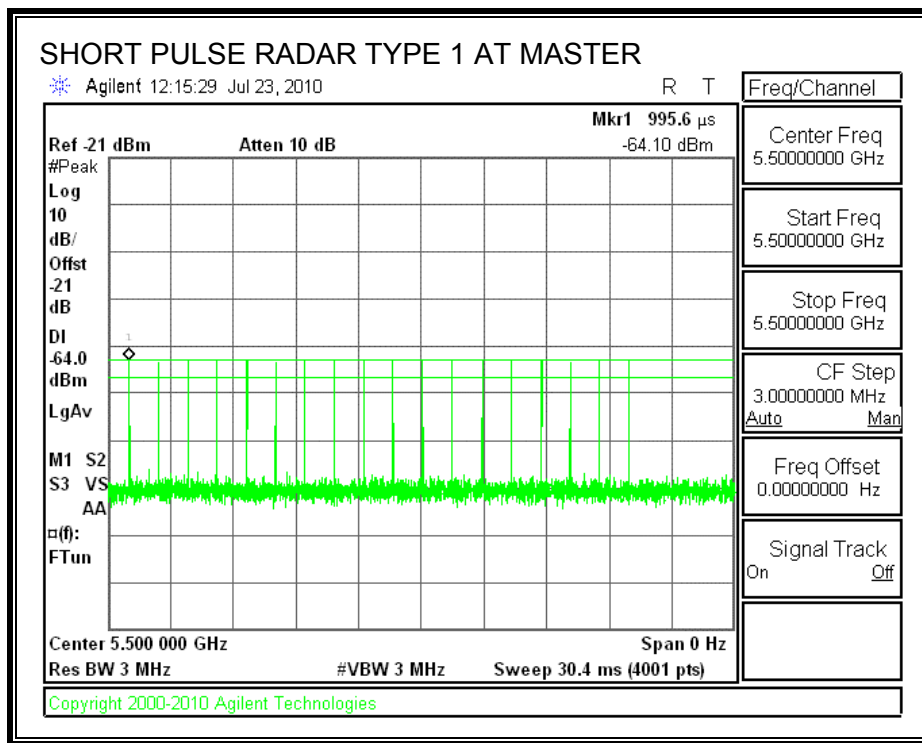

**TRAFFIC**

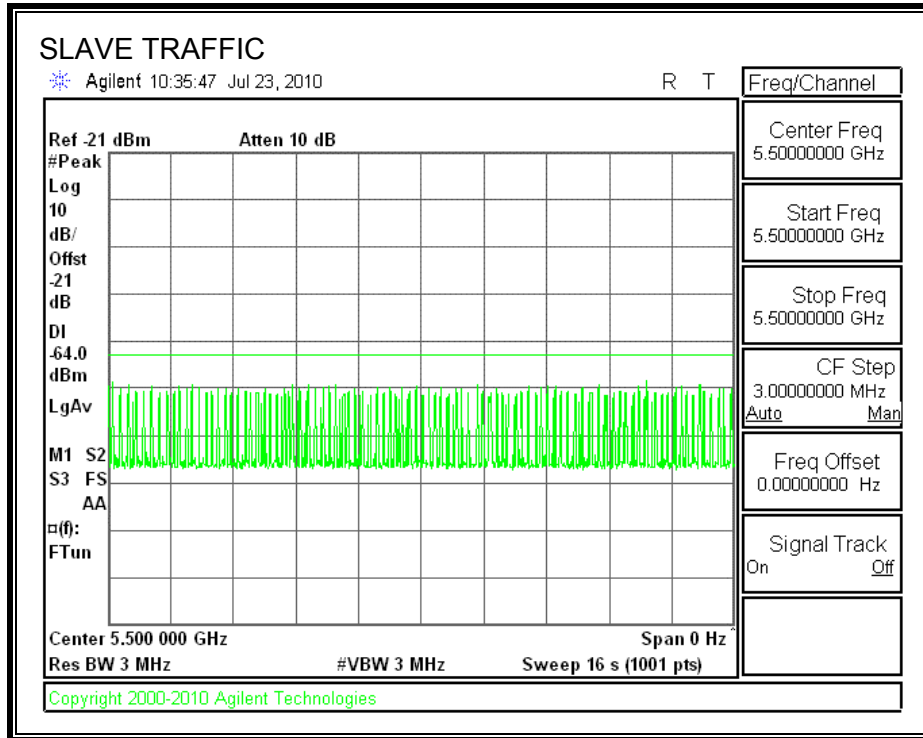

**10.2.3. OVERLAPPING CHANNEL TESTS**

**RESULTS**

These tests are not applicable.

**10.2.4. MOVE AND CLOSING TIME**

**REPORTING NOTES**

The reference marker is set at the end of last radar pulse.

The delta marker is set at the end of the last WLAN transmission following the radar pulse. This delta is the channel move time.

The aggregate channel closing transmission time is calculated as follows:

Aggregate Transmission Time =  
 (Number of analyzer bins showing transmission) \* (dwell time per bin)

The observation period over which the FCC aggregate time is calculated begins at (Reference Marker + 200 msec) and ends no earlier than (Reference Marker + 10 sec).

The observation period over which the IC aggregate time is calculated begins at (Reference Marker) and ends no earlier than (Reference Marker + 10 sec).

**RESULTS**

Agency	Channel Move Time (sec)	Limit (sec)
FCC / IC	4.180	10

Agency	Aggregate Channel Closing Transmission Time (msec)	Limit (msec)
FCC	48.8	60
IC	52.7	260

**MOVE TIME**

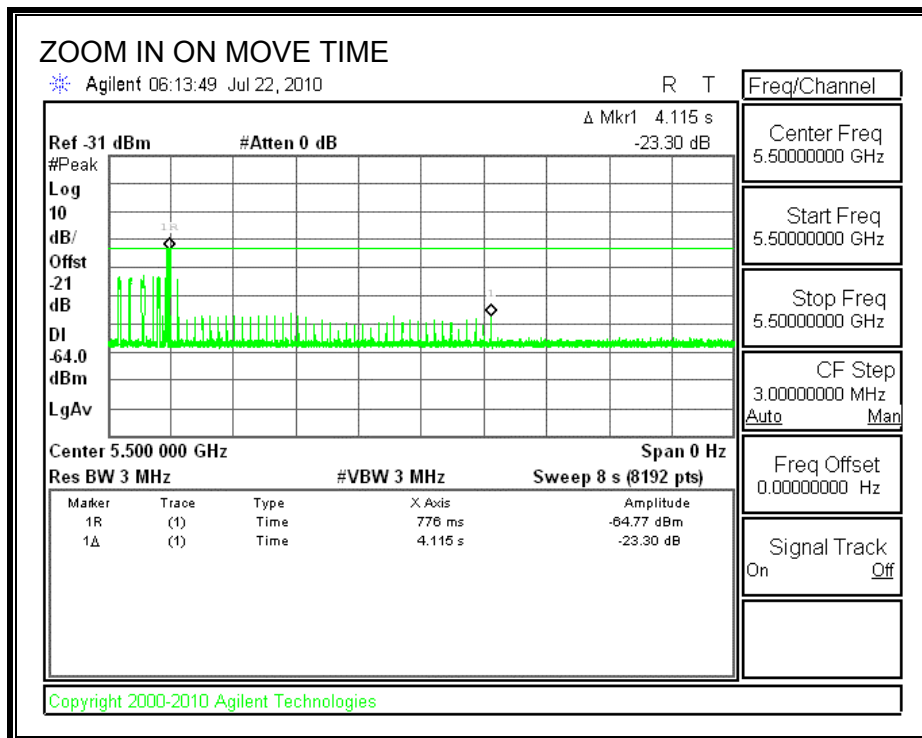
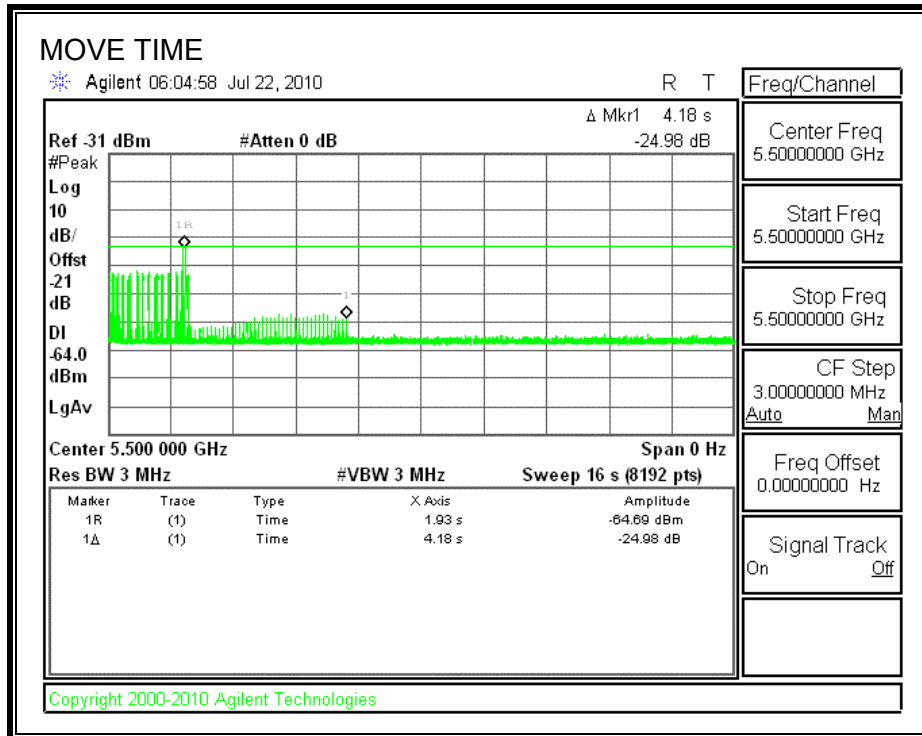

**CHANNEL CLOSING TIME**

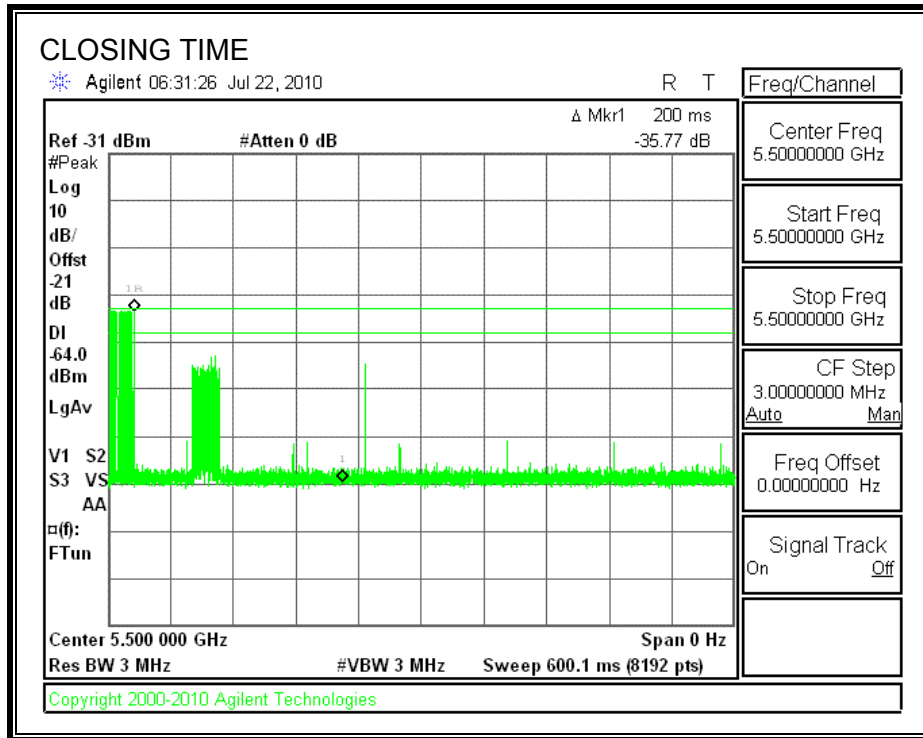



**AGGREGATE CHANNEL CLOSING TRANSMISSION TIME**

Only intermittent transmissions are observed during the FCC aggregate monitoring period.

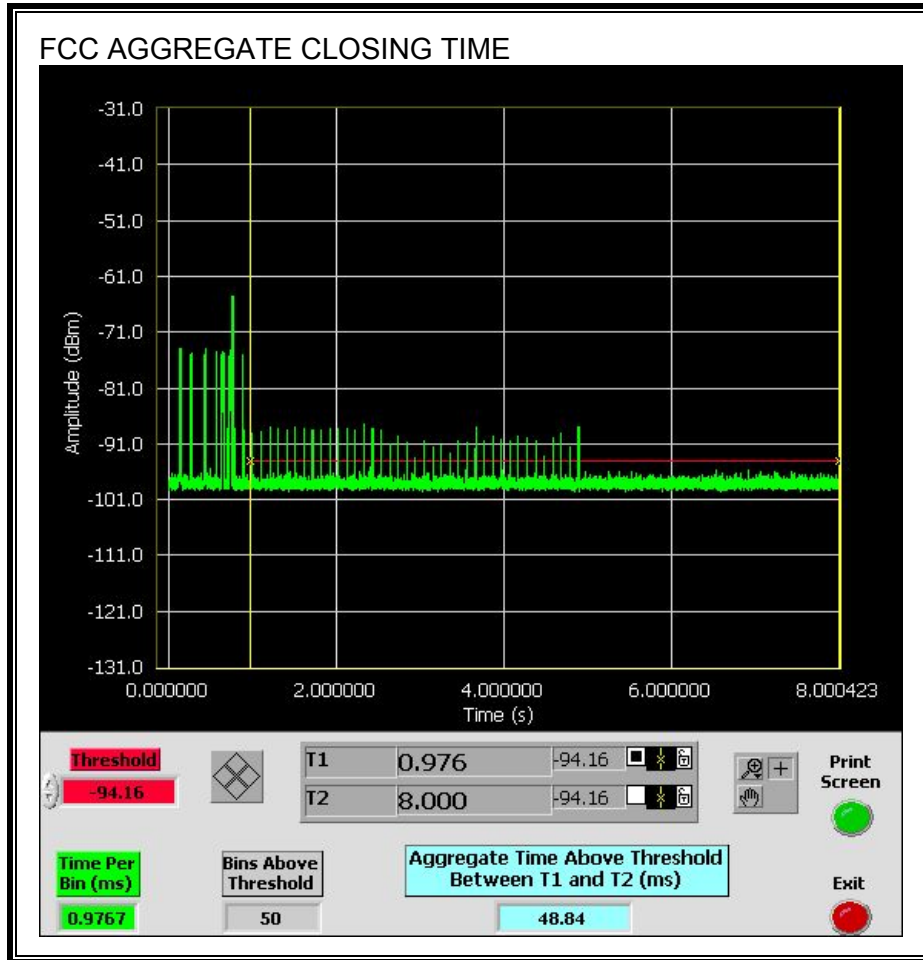

Only intermittent transmissions are observed during the IC aggregate monitoring period.

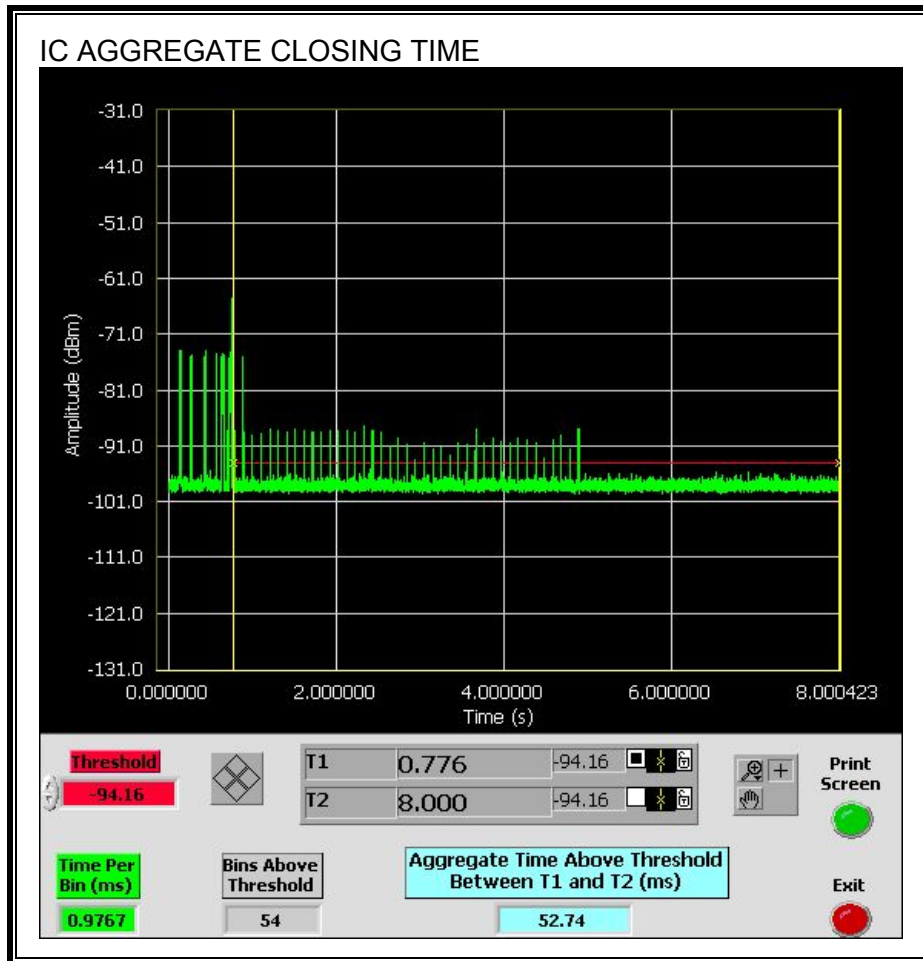

### 10.3. RESULTS FOR 40 MHz BANDWIDTH

#### 10.3.1. TEST CHANNEL

All tests were performed at a channel center frequency of 5510 MHz.

#### 10.3.2. RADAR WAVEFORM AND TRAFFIC

##### RADAR WAVEFORM

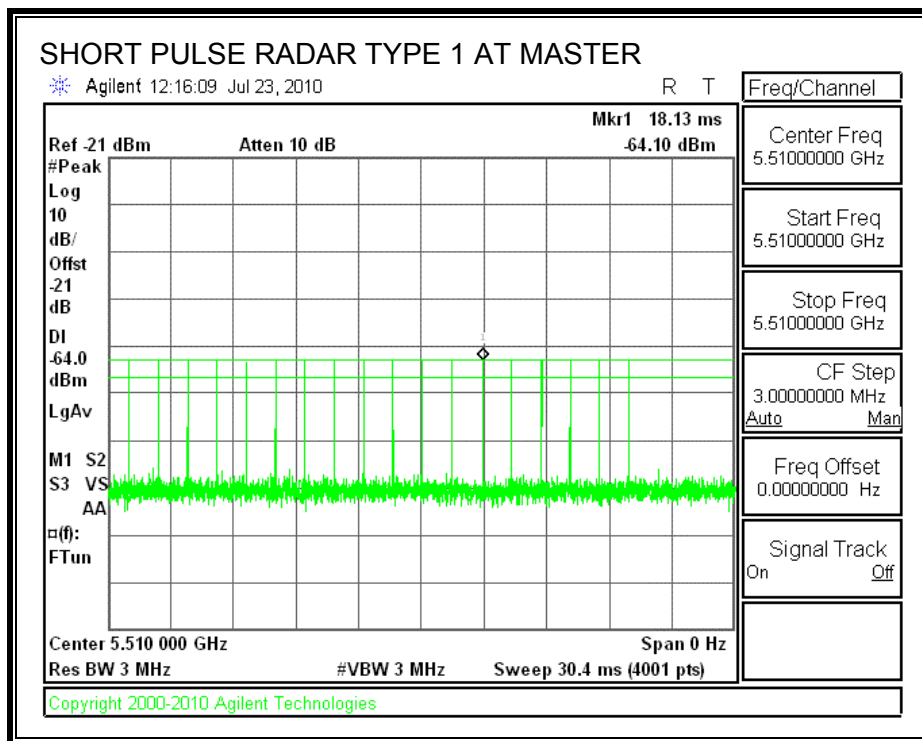

**TRAFFIC**

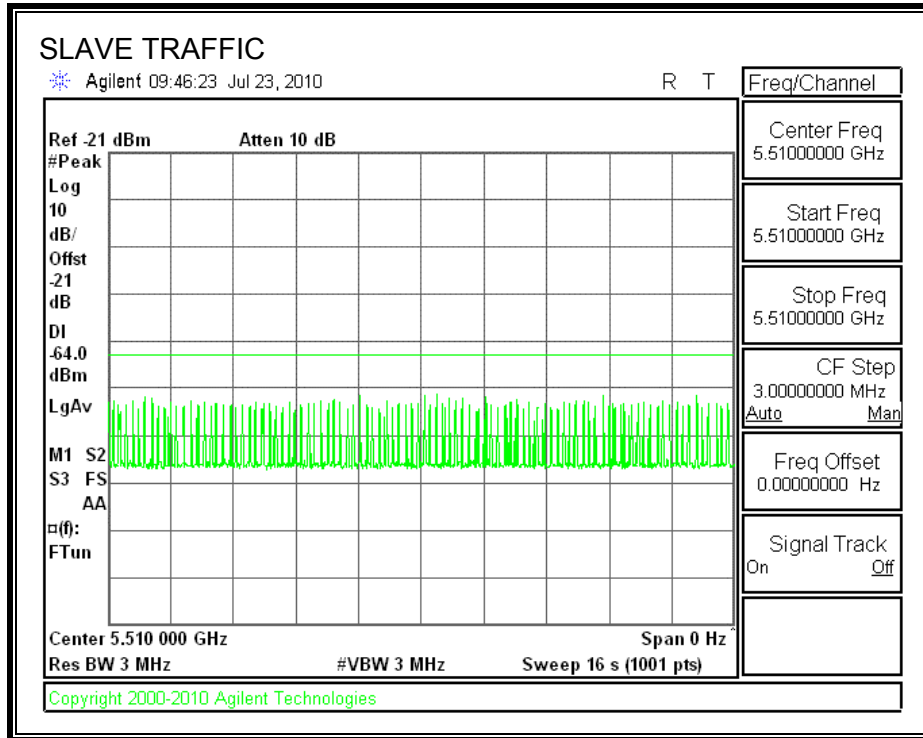

**10.3.3. OVERLAPPING CHANNEL TESTS**

**RESULTS**

These tests are not applicable.

**10.3.4. MOVE AND CLOSING TIME**

**REPORTING NOTES**

The reference marker is set at the end of last radar pulse.

The delta marker is set at the end of the last WLAN transmission following the radar pulse. This delta is the channel move time.

The aggregate channel closing transmission time is calculated as follows:

Aggregate Transmission Time =  
 (Number of analyzer bins showing transmission) \* (dwell time per bin)

The observation period over which the FCC aggregate time is calculated begins at (Reference Marker + 200 msec) and ends no earlier than (Reference Marker + 10 sec).

The observation period over which the IC aggregate time is calculated begins at (Reference Marker) and ends no earlier than (Reference Marker + 10 sec).

**RESULTS**

Agency	Channel Move Time (sec)	Limit (sec)
FCC / IC	4.456	10

Agency	Aggregate Channel Closing Transmission Time (msec)	Limit (msec)
FCC	35.2	60
IC	52.7	260

**MOVE TIME**

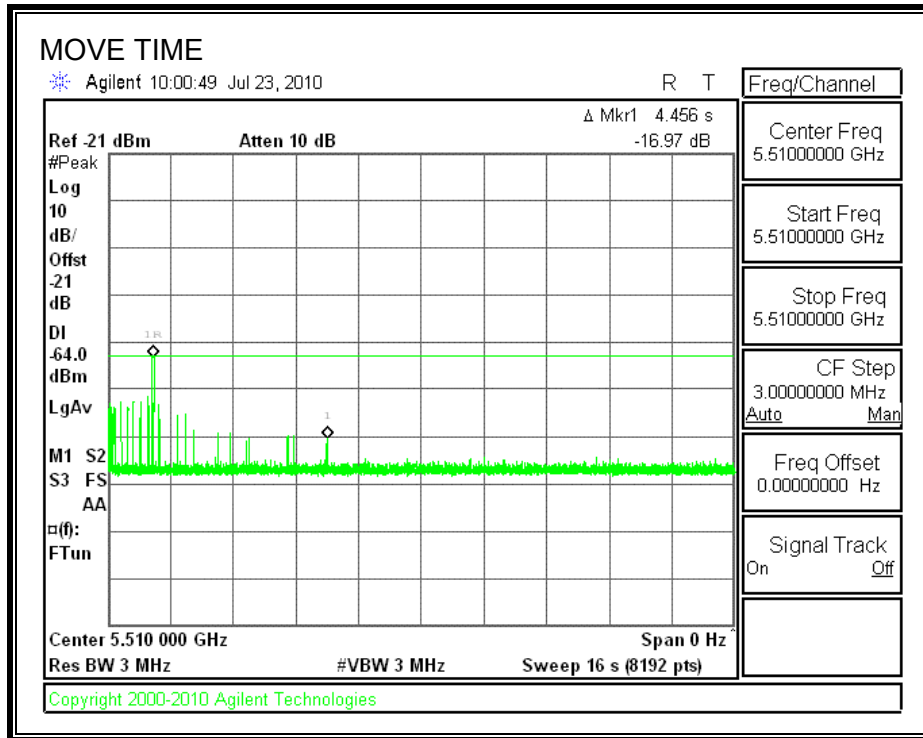

**CHANNEL CLOSING TIME**

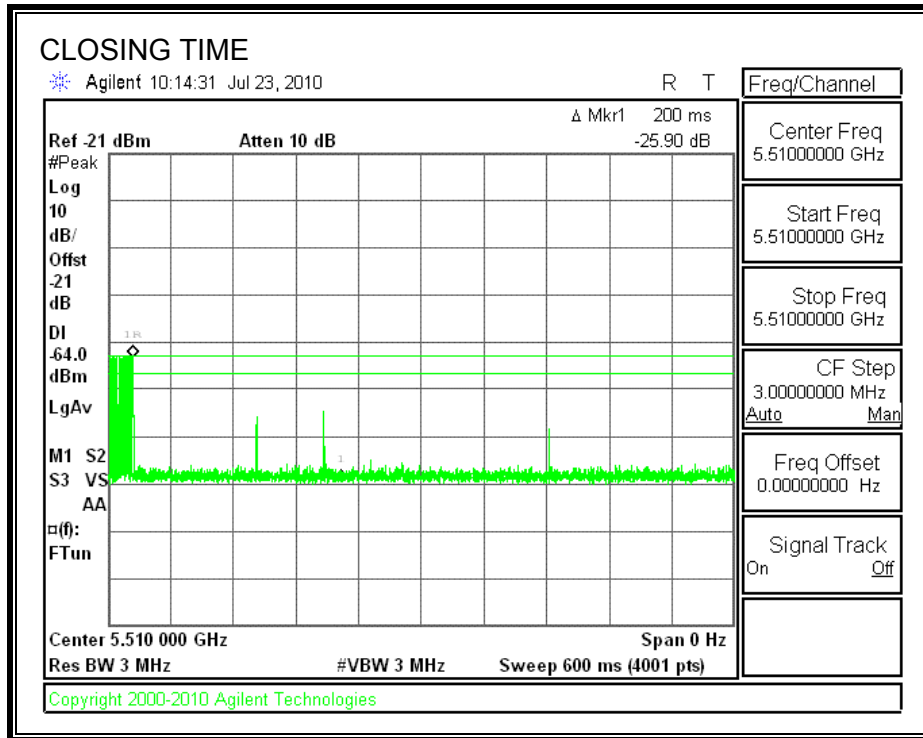

**AGGREGATE CHANNEL CLOSING TRANSMISSION TIME**

Only intermittent transmissions are observed during the FCC aggregate monitoring period.

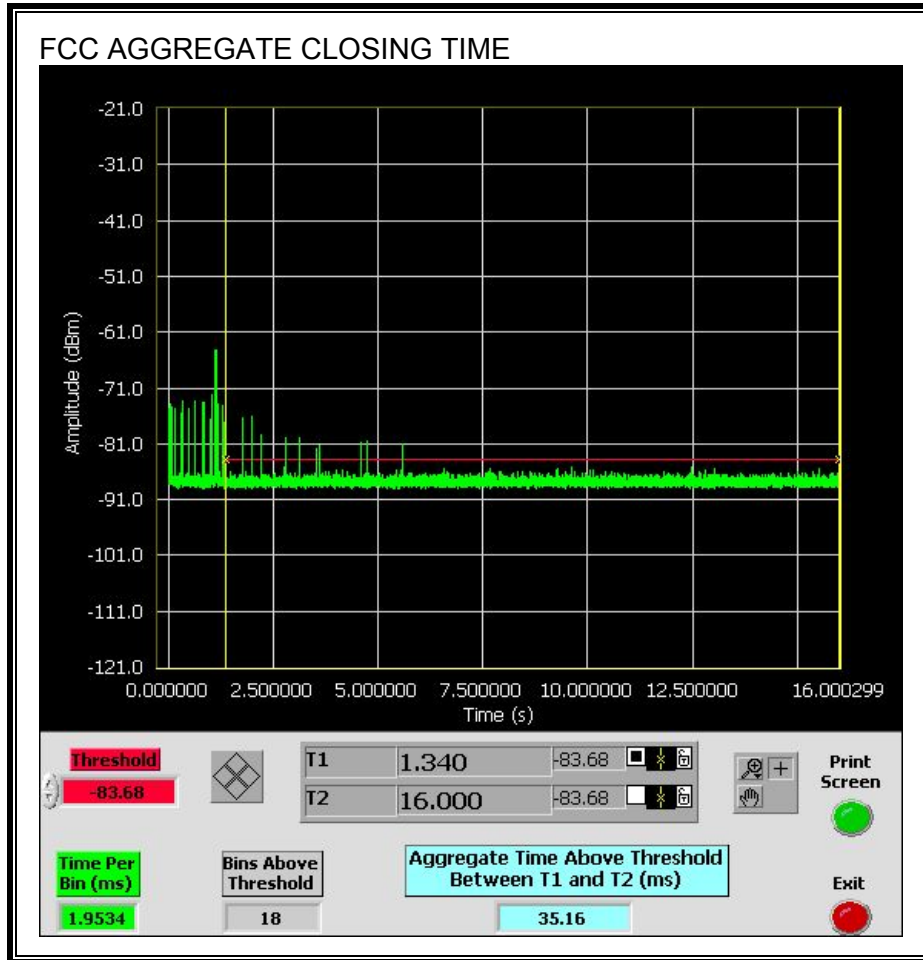



Only intermittent transmissions are observed during the IC aggregate monitoring period.

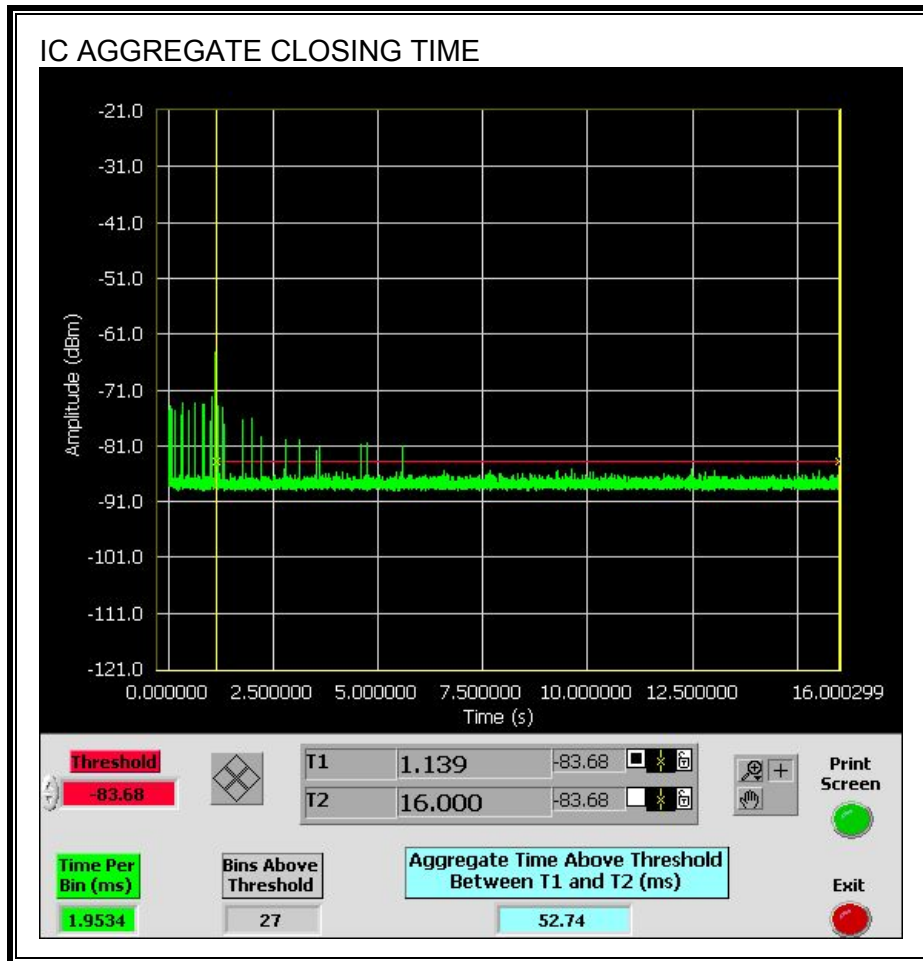

### 10.3.5. NON-OCCUPANCY PERIOD

#### RESULTS

No EUT transmissions were observed on the test channel during the 30-minute observation time.

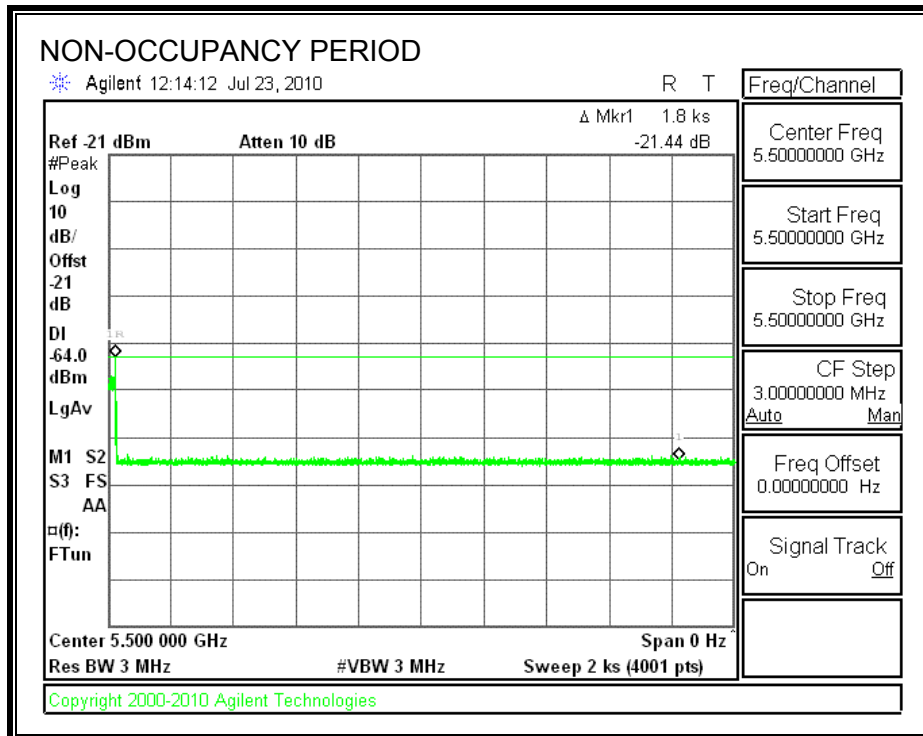

## 11. MAXIMUM PERMISSIBLE EXPOSURE

### FCC RULES

§1.1310 The criteria listed in Table 1 shall be used to evaluate the environmental impact of human exposure to radio-frequency (RF) radiation as specified in §1.1307(b), except in the case of portable devices which shall be evaluated according to the provisions of §2.1093 of this chapter.

TABLE 1—LIMITS FOR MAXIMUM PERMISSIBLE EXPOSURE (MPE)

Frequency range (MHz)	Electric field strength (V/m)	Magnetic field strength (A/m)	Power density (mW/cm <sup>2</sup> )	Averaging time (minutes)
(A) Limits for Occupational/Controlled Exposures				
0.3–3.0 .....	614	1.63	*(100)	6
3.0–30 .....	1842/f	4.89/f	*(900/f <sup>2</sup> )	6
30–300 .....	61.4	0.163	1.0	6
300–1500 .....	.....	.....	f/300	6
1500–100,000 .....	.....	.....	5	6
(B) Limits for General Population/Uncontrolled Exposure				
0.3–1.34 .....	614	1.63	*(100)	30
1.34–30 .....	824/f	2.19/f	*(180/f <sup>2</sup> )	30

TABLE 1—LIMITS FOR MAXIMUM PERMISSIBLE EXPOSURE (MPE)—Continued

Frequency range (MHz)	Electric field strength (V/m)	Magnetic field strength (A/m)	Power density (mW/cm <sup>2</sup> )	Averaging time (minutes)
30–300 .....	27.5	0.073	0.2	30
300–1500 .....	.....	.....	f/1500	30
1500–100,000 .....	.....	.....	1.0	30

f = frequency in MHz

\* = Plane-wave equivalent power density

NOTE 1 TO TABLE 1: Occupational/controlled limits apply in situations in which persons are exposed as a consequence of their employment provided those persons are fully aware of the potential for exposure and can exercise control over their exposure. Limits for occupational/controlled exposure also apply in situations when an individual is transient through a location where occupational/controlled limits apply provided he or she is made aware of the potential for exposure.

NOTE 2 TO TABLE 1: General population/uncontrolled exposures apply in situations in which the general public may be exposed, or in which persons that are exposed as a consequence of their employment may not be fully aware of the potential for exposure or can not exercise control over their exposure.

**IC RULES**

IC Safety Code 6, Section 2.2.1 (a) A person other than an RF and microwave exposed worker shall not be exposed to electromagnetic radiation in a frequency band listed in Column 1 of Table 5, if the field strength exceeds the value given in Column 2 or 3 of Table 5, when averaged spatially and over time, or if the power density exceeds the value given in Column 4 of Table 5, when averaged spatially and over time.

**Table 5  
 Exposure Limits for Persons Not Classed As RF and Microwave Exposed Workers (Including the General Public)**

1 Frequency (MHz)	2 Electric Field Strength; rms (V/m)	3 Magnetic Field Strength; rms (A/m)	4 Power Density (W/m <sup>2</sup> )	5 Averaging Time (min)
0.003–1	280	2.19		6
1–10	280/ <i>f</i>	2.19/ <i>f</i>		6
10–30	28	2.19/ <i>f</i>		6
30–300	28	0.073	2*	6
300–1 500	1.585 <i>f</i> <sup>0.5</sup>	0.0042 <i>f</i> <sup>0.5</sup>	<i>f</i> /150	6
1 500–15 000	61.4	0.163	10	6
15 000–150 000	61.4	0.163	10	616 000 / <i>f</i> <sup>1.2</sup>
150 000–300 000	0.158 <i>f</i> <sup>0.5</sup>	4.21 x 10 <sup>-4</sup> <i>f</i> <sup>0.5</sup>	6.67 x 10 <sup>-5</sup> <i>f</i>	616 000 / <i>f</i> <sup>1.2</sup>

\* Power density limit is applicable at frequencies greater than 100 MHz.

- Notes:**
1. Frequency, *f*, is in MHz.
  2. A power density of 10 W/m<sup>2</sup> is equivalent to 1 mW/cm<sup>2</sup>.
  3. A magnetic field strength of 1 A/m corresponds to 1.257 microtesla (μT) or 12.57 milligauss (mG).

**EQUATIONS**

Power density is given by:

$$S = \text{EIRP} / (4 * \text{Pi} * D^2)$$

where

- S = Power density in W/m<sup>2</sup>
- EIRP = Equivalent Isotropic Radiated Power in W
- D = Separation distance in m

Power density in units of W/m<sup>2</sup> is converted to units of mWc/m<sup>2</sup> by dividing by 10.

Distance is given by:

$$D = \text{SQRT} (\text{EIRP} / (4 * \text{Pi} * S))$$

where

- D = Separation distance in m
- EIRP = Equivalent Isotropic Radiated Power in W
- S = Power density in W/m<sup>2</sup>

For multiple colocated transmitters operating simultaneously in frequency bands where the limit is identical, the total power density is calculated using the total EIRP obtained by summing the Power \* Gain product (in linear units) of each transmitter.

$$\text{Total EIRP} = (P1 * G1) + (P2 * G2) + \dots + (Pn * Gn)$$

where

- Px = Power of transmitter x
- Gx = Numeric gain of antenna x

In the table(s) below, Power and Gain are entered in units of dBm and dBi respectively and conversions to linear forms are used for the calculations.

**LIMITS**

From FCC §1.1310 Table 1 (B), the maximum value of S = 1.0 mW/cm<sup>2</sup>  
 From IC Safety Code 6, Section 2.2 Table 5 Column 4, S = 10 W/m<sup>2</sup>

**RESULTS**

(MPE distance equals 20 cm)

Mode	Band	MPE Distance (cm)	Output Power (dBm)	Antenna Gain (dBi)	FCC Power Density (mW/cm <sup>2</sup> )	IC Power Density (W/m <sup>2</sup> )
WLAN	5 GHz	20.0	19.97	9.22	0.16	1.65