



**FCC 47 CFR PART 15 SUBPART C AND ANSI C63.4:2003
TEST REPORT (Class II Permissive Change Report)**

For

802.11g/DRAFT 802.11n WIRELESS LAN PCI-E MINICARD

Model : BCM94313HMG2L

Trade Name : Broadcom

Issued for

BROADCOM CORPORATION

190 MATHILDA PLACE SUNNYVALE, CA 94086, U.S.A.

Issued by

**Compliance Certification Services Inc.
Hsinchu Lab.**

**NO. 989-1 Wen Shan Rd., Shang Shan Village,
Qionglin Shiang Hsinchu County 30741, Taiwan, R.O.C**

TEL: +886-3-5921698

FAX: +886-3-5921108

<http://www.ccsrf.com>

E-Mail : service@ccsrf.com

Issued Date: March 07, 2012



Note: This report shall not be reproduced except in full, without the written approval of Compliance Certification Services Inc. This document may be altered or revised by Compliance Certification Services Inc. personnel only, and shall be noted in the revision section of the document. The client should not use it to claim product endorsement by TAF or any government agencies. The test results of this report relate only to the tested sample identified in this report.



Revision History

Rev.	Issue Date	Revisions	Effect Page	Revised By
00	12/18/2011	Initial Issue	All Page 36	Cindy Pon
01	03/03/2012	Revised the Description of Class II Change.	Page 6	Cindy Pon
02	03/07/2012	Revised the Maximum Peak Output Power.	Page 5, 11, 14	Cindy Pon



TABLE OF CONTENTS

TITLE	PAGE NO.
1. TEST REPORT CERTIFICATION	4
2. EUT DESCRIPTION	5
3. DESCRIPTION OF CLASS II CHANGE.....	6
4. DESCRIPTION OF TEST MODES	6
5. TEST METHODOLOGY	6
6. FACILITIES AND ACCREDITATION.....	7
6.1 FACILITIES	7
6.2 ACCREDITATIONS.....	7
6.3 MEASUREMENT UNCERTAINTY	8
7. SETUP OF EQUIPMENT UNDER TEST.....	9
8. FCC PART 15.247 REQUIREMENTS.....	10
8.1 MAXIMUM PEAK OUTPUT POWER	10-15
8.2 RADIATED EMISSION.....	16-35
APPENDIX SETUP PHOTOS	36



1. TEST REPORT CERTIFICATION

Applicant : BROADCOM CORPORATION
Address : 190 MATHILDA PLACE SUNNYVALE, CA 94086, U.S.A.
Equipment Under Test : 802.11g/DRAFT 802.11n WIRELESS LAN PCI-E MIMICARD
Model : BCM94313HMG2L
Trade Name : Broadcom
Tested Date : December 05 ~ 18, 2011

APPLICABLE STANDARD	
Standard	Test Result
FCC Part 15 Subpart C AND ANSI C63.4:2003	PASS

WE HEREBY CERTIFY THAT: The above equipment has been tested by Compliance Certification Services Inc., and found compliance with the requirements set forth in the technical standards mentioned above. The results of testing in this report apply only to the product/system, which was tested. Other similar equipment will not necessarily produce the same results due to production tolerance and measurement uncertainties.

Approved by:

Rex Liao
Deputy Section Manager

Reviewed by:

Jacky Chen
Deputy Section Manager

**2. EUT DESCRIPTION**

Product Name	802.11g/DRAFT 802.11n WIRELESS LAN PCI-E MINICARD
Model Number	BCM94313HMG2L
Identify Number	T111111108
Received Date	December 05, 2011
Frequency Range	IEEE 802.11b/g : 2412MHz~2462MHz
Transmit Power	IEEE 802.11b : 20.73dBm (0.1183 W) IEEE 802.11g : 25.22dBm (0.3327 W)
Channel Spacing	IEEE 802.11b/g : 5MHz
Channel Number	IEEE 802.11b/g : 11 Channels
Transmit Data Rate	IEEE 802.11b : 11, 5.5, 2, 1 Mbps IEEE 802.11g : 54, 48, 36, 24, 18, 12, 9, 6 Mbps
Type of Modulation	IEEE 802.11b : DSSS (CCK, DQPSK, DBPSK) IEEE 802.11g : OFDM (64QAM, 16QAM, QPSK, BPSK)
Frequency Selection	by software / firmware
Antenna Type	PIFA Antenna, Antenna Gain :1.74dBi
Power Rating	20Vdc, 4.5A (From Power Adapter)
Test Voltage	120Vac/60Hz
DC Power Cable Type	Non-shielded cable 1.8m (Non-detachable)
I/O Port	USB 2.0 Port x 1, RJ-45 Port x 1, HDMI Port x 1, USB 3.0 Port x 2, VGA Port x 1, Audio In Port x 1, Audio Out Port x 1, SD Card Port x 1, Power Port x 1

Power Adapter :

No.	Manufacturer	Model No.	Power Input	Power Output
1	lenovo	ADP-90DD B	100-240Vac, 50/60Hz, 1.5A	20Vdc, 4.5A

Remark :

1. The sample selected for test was engineering sample that approximated to production product and was provided by manufacturer.
2. For more details, please refer to the User's manual of the EUT.
3. This submittal(s) (test report) is intended for FCC ID: QDS-BRCM1050I filing to comply with Section 15.207, 15.209 and 15.247 of the FCC Part 15, Subpart C Rules.



3. DESCRIPTION OF CLASS II CHANGE

The major change filed under this application is:

1. The operation frequency is 2412MHz~2462MHz.
2. Add portable condition compliance to the grant so that the module may be used in qualified host PC(s) and implementation of module-notebook authentication.

Product name: Notebook Computer

Brand name: lenovo

Model: 20134, 2148, Lenovo IdeaPad Z480

The above model numbers have the same specifications.

4. DESCRIPTION OF TEST MODES

Radiated Emission Test (Below 1 GHz)

TX Mode

Conducted / Radiated Emission Test (Above 1 GHz)

IEEE 802.11b, 802.11g, 802.11n HT20 mode

The EUT had been tested under operating condition.

There are three channels have been tested as following :

Channel	Frequency (MHz)
Low	2412
Middle	2437
High	2462

IEEE 802.11b mode : 1Mbps data rate (worst case) were chosen for full testing.

IEEE 802.11g mode : 6Mbps data rate (worst case) were chosen for full testing.

IEEE 802.11n HT20 mode : Covered by the worst case 802.11g Mode Legacy testing.

5. TEST METHODOLOGY

The tests documented in this report were performed in accordance with ANSI C63.4: 2003 and FCC CFR 47, 15.207, 15.209 and 15.247.



6. FACILITIES AND ACCREDITATION

6.1 FACILITIES

All measurement facilities used to collect the measurement data are located at

NO. 989-1 Wen Shan Rd., Shang Shan Village,
Qionglin Shiang Hsinchu County 30741, Taiwan, R.O.C

The sites are constructed in conformance with the requirements of ANSI C63.4:2003 and CISPR 22. All receiving equipment conforms to CISPR 16-1-1, CISPR 16-1-2, CISPR 16-1-3, CISPR 16-1-4, CISPR 16-1-5.

6.2 ACCREDITATIONS

Our laboratories are accredited and approved by the following approval agencies according to ISO/IEC 17025.

Taiwan	TAF
---------------	-----

The measuring facility of laboratories has been authorized or registered by the following approval agencies.

Canada	INDUSTRY CANADA
Japan	VCCI
Taiwan	BSMI
USA	FCC MRA

Copies of granted accreditation certificates are available for downloading from our web site, <http://www.ccsrf.com>



6.3 MEASUREMENT UNCERTAINTY

The following table is for the measurement uncertainty, which is calculated as per the document CISPR 16-4-2.

PARAMETER	UNCERTAINTY
Semi Anechoic Chamber (966 Chamber_A) / Radiated Emission, 30 to 1000 MHz	+/- 3.0371
Semi Anechoic Chamber (966 Chamber_A) / Radiated Emission, 1 to 18GHz	+/- 2.5258
Semi Anechoic Chamber (966 Chamber_A) / Radiated Emission, 18 to 26 GHz	+/- 2.5012
Semi Anechoic Chamber (966 Chamber_A) / Radiated Emission, 26 to 40 GHz	+/- 2.7846
Semi Anechoic Chamber (966 Chamber_B) / Radiated Emission, 30 to 1000 MHz	+/- 3.5189
Semi Anechoic Chamber (966 Chamber_B) / Radiated Emission, 1 to 18GHz	+/- 2.5164
Semi Anechoic Chamber (966 Chamber_B) / Radiated Emission, 18 to 26 GHz	+/- 2.4967
Semi Anechoic Chamber (966 Chamber_B) / Radiated Emission, 26 to 40 GHz	+/- 2.7655

This uncertainty represents an expanded uncertainty expressed at approximately the 95% confidence level using a coverage factor of k=2.

Consistent with industry standard (e.g. CISPR 22: 2006, clause 11, Measurement Uncertainty) determining compliance with the limits shall be base on the results of the compliance measurement. Consequently the measure emissions being less than the maximum allowed emission result in this be a compliant test or passing test.

The acceptable measurement uncertainty value without requiring revision of the compliance statement is base on conducted and radiated emissions being less than U_{CISPR} which is 3.6dB and 5.2dB respectively. CCS values (called U_{Lab} in CISPR 16-4-2) is less than U_{CISPR} as shown in the table above. Therefore, MU need not be considered for compliance.



7. SETUP OF EQUIPMENT UNDER TEST

SUPPORT EQUIPMENT

N/A

SETUP DIAGRAM FOR TESTS

EUT & peripherals setup diagram is shown in appendix setup photos.

EUT OPERATING CONDITION

1. Setup all computers like the setup diagram.
2. Run Test software..
3. Select the following settings
4. net stop wlansvc
timeout 1
net start wlansvc
timeout 4
wl out
wl up
wl antdiv 0
wl txant 0
wl mpc 0
wl frameburst 1
wl down
wl ampdu 1
wl country ALL
wl band b
wl up
wl chanspec -c 1 -b 2 -w 20 -s 0
timeout 4
wl wsec 0
timeout 4
wl join testb imode adhoc
timeout 4
wl legacylink
timeout 6
wl nrate -r 1
wl cck_txbw 2
wl txpwr1 -o -q 75
timeout 4
epi_tcp -tsuHfm -l 8760 -n 10000000 192.168.66.255
- 6.All of the functions are under run.
- 7.Start test.



8. FCC PART 15.247 REQUIREMENTS

8.1 MAXIMUM PEAK OUTPUT POWER

LIMITS

§ 15.247(b) The maximum peak output power of the intentional radiator shall not exceed the following :

§ 15.247(b) (3) For systems using digital modulation in the 902-928 MHz, 2400-2483.5 MHz, and 5725-5850 MHz bands : 1 watt.

§ 15.247(b) (4) Except as shown in paragraphs (c) of this section, if transmitting antennas of directional gain greater than 6 dBi are used the peak output power from the intentional radiator shall be reduced below the stated values in paragraphs (b)(1) or (b)(2), and (b)(3) of this section, as appropriate, by the amount in dB that the directional gain of the antenna exceeds 6 dBi.

TEST EQUIPMENT

Name of Equipment	Manufacturer	Model	Serial Number	Calibration Due
Spectrum Analyzer	Agilent	E4407B	US41443108	08/09/2012

Remark: Each piece of equipment is scheduled for calibration once a year.

TEST SETUP

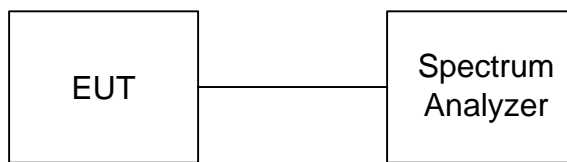

TEST PROCEDURE

- The spectrum shall be set as follows :
 - Span : 1.5 times channel integration bandwidth.
 - RBW : 1MHz
 - VBW : 3MHz
 - Detector : Peak
 - Sweep : Single trace
- Compute the combined power of all signal responses contained in the trace by covering all the data points.
- The peak output power is the channel power integrated over 26dB bandwidth.



TEST RESULTS

IEEE 802.11b Mode

Channel	Channel Frequency (MHz)	Peak Power		Peak Power Limit		Pass / Fail
		(dBm)	(W)	(dBm)	(W)	
Low	2412	19.47	0.0885	30	1	PASS
Middle	2437	20.73	0.1183	30	1	PASS
High	2462	15.99	0.0397	30	1	PASS

Remark:

1. At final test to get the worst-case emission at 1Mbps.
2. The cable assembly insertion loss of 11.5dB (including 10 dB pad and 1.5 dB cable) was Entered as an offset in the spectrum analyzer to allow for direct reading of power.

IEEE 802.11g Mode

Channel	Channel Frequency (MHz)	Peak Power		Peak Power Limit		Pass / Fail
		(dBm)	(W)	(dBm)	(W)	
Low	2412	23.40	0.2188	30	1	PASS
Middle	2437	25.22	0.3327	30	1	PASS
High	2462	17.05	0.0507	30	1	PASS

Remark:

1. At final test to get the worst-case emission at 6Mbps.
2. The cable assembly insertion loss of 11.5dB (including 10 dB pad and 1.5 dB cable) was Entered as an offset in the spectrum analyzer to allow for direct reading of power.



MAXIMUM PEAK OUTPUT POWER

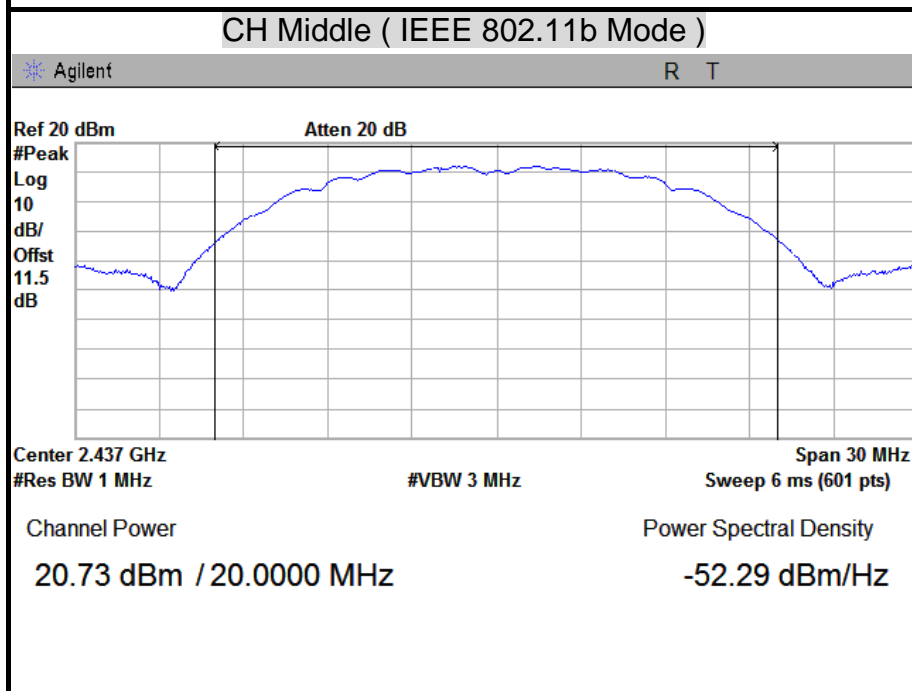
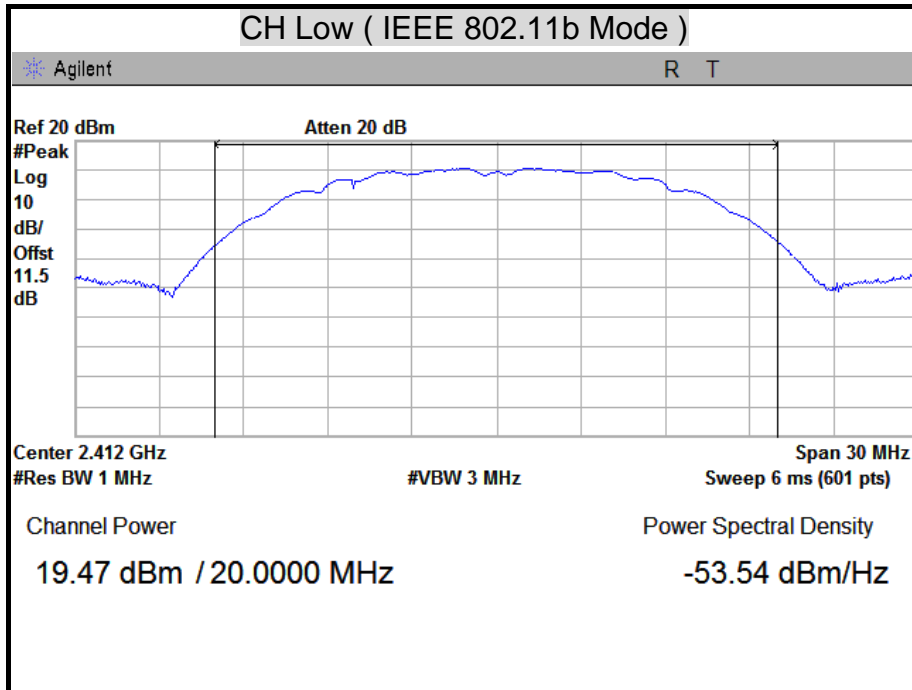

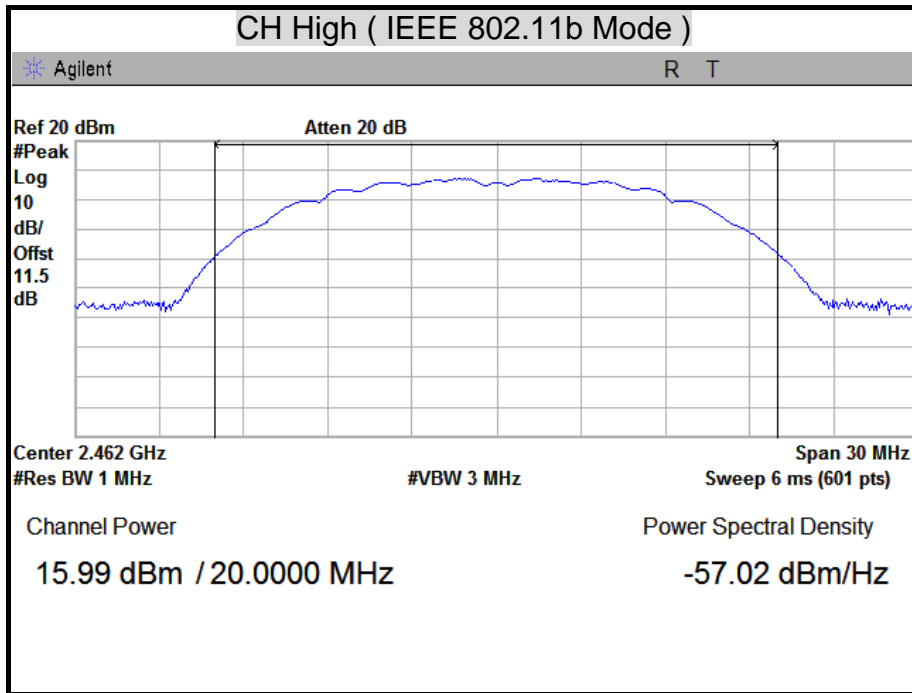

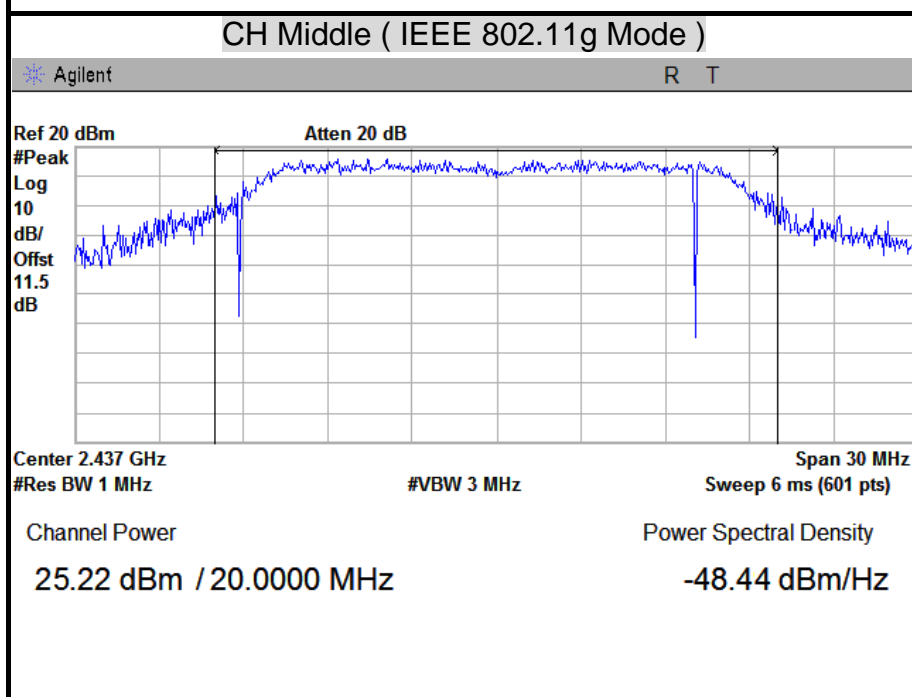
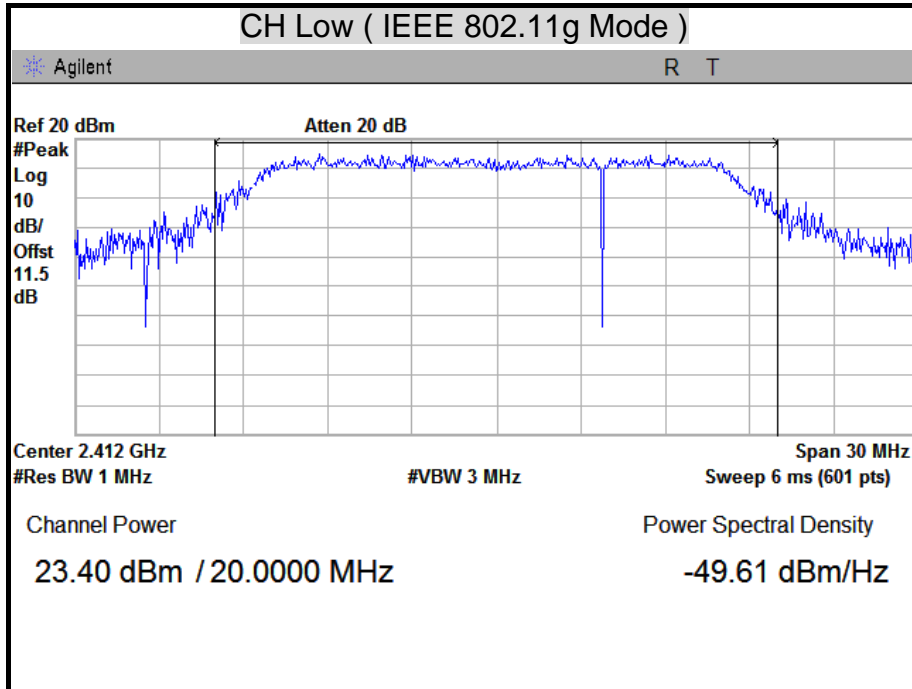

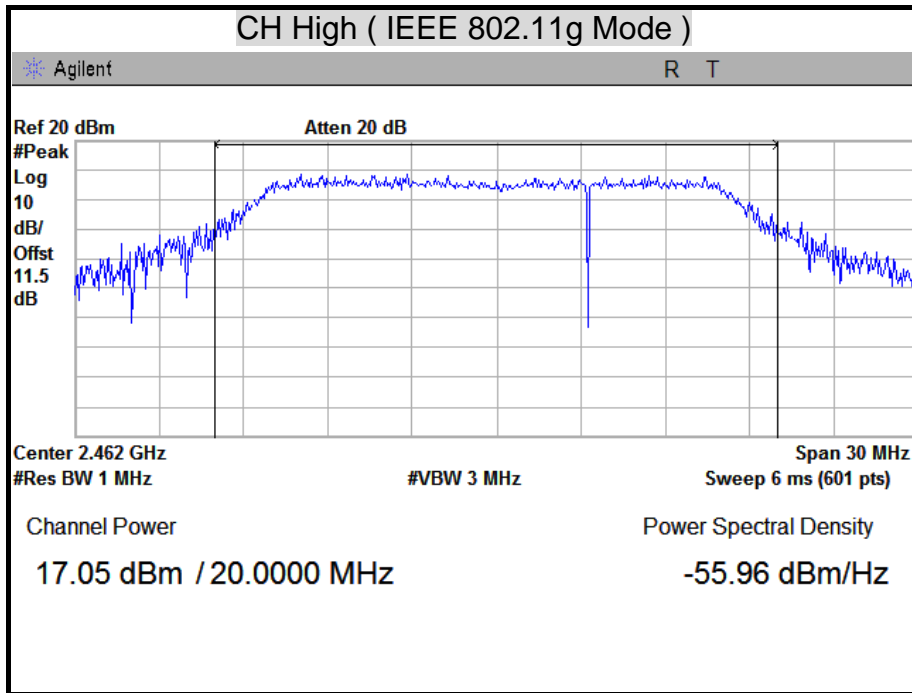



8.2 RADIATED EMISSION

LIMITS

(1) According to § 15.205 (a) Except as shown in paragraph (d) of this section, only spurious emissions are permitted in any of the frequency bands listed below:

MHz	MHz	MHz	GHz
0.090 - 0.110	16.42 - 16.423	399.9 - 410	4.5 - 5.15
¹ 0.495 - 0.505	16.69475 - 16.69525	608 - 614	5.35 - 5.46
2.1735 - 2.1905	16.80425 - 16.80475	960 - 1240	7.25 - 7.75
4.125 - 4.128	25.5 - 25.67	1300 - 1427	8.025 - 8.5
4.17725 - 4.17775	37.5 - 38.25	1435 - 1626.5	9.0 - 9.2
4.20725 - 4.20775	73 - 74.6	1645.5 - 1646.5	9.3 - 9.5
6.215 - 6.218	74.8 - 75.2	1660 - 1710	10.6 - 12.7
6.26775 - 6.26825	108 - 121.94	1718.8 - 1722.2	13.25 - 13.4
6.31175 - 6.31225	123 - 138	2200 - 2300	14.47 - 14.5
8.291 - 8.294	149.9 - 150.05	2310 - 2390	15.35 - 16.2
8.362 - 8.366	156.52475 - 156.52525	2483.5 - 2500	17.7 - 21.4
8.37625 - 8.38675	156.7 - 156.9	2655 - 2900	22.01 - 23.12
8.41425 - 8.41475	162.0125 - 167.17	3260 - 3267	23.6 - 24.0
12.29 - 12.293	167.72 - 173.2	3332 - 3339	31.2 - 31.8
12.51975 - 12.52025	240 - 285	3345.8 - 3338	36.43 - 36.5
12.57675 - 12.57725	322 - 335.4	3600 - 4400	(²)
13.36 - 13.41			

Remark:

- 1. ¹ Until February 1, 1999, this restricted band shall be 0.490-0.510 MHz.
- 2. ² Above 38.6

(2) According to § 15.205 (b) Except as provided in paragraphs (d) and (e), the field strength of emissions appearing within these frequency bands shall not exceed the limits shown in Section 15.209. At frequencies equal to or less than 1000 MHz, compliance with the limits in Section 15.209 shall be demonstrated using measurement instrumentation employing a CISPR quasi-peak detector. Above 1000 MHz, compliance with the emission limits in Section 15.209 shall be demonstrated based on the average value of the measured emissions. The provisions in Section 15.35 apply to these measurements.



(3) According to § 15.209 (a) Except as provided elsewhere in this Subpart, the emissions from an intentional radiator shall not exceed the field strength levels specified in the following table :

Frequency (MHz)	Field Strength (microvolts/meter)	Measurement Distance (meters)
0.009 – 0.490	2400/F(KHz)	300
0.490 – 1.705	24000/F(KHz)	30
1.705 – 30.0	30	30
30 - 88	100 **	3
88 - 216	150 **	3
216 - 960	200 **	3
Above 960	500	3

Remark: **Except as provided in paragraph (g), fundamental emissions from intentional radiators operating under this Section shall not be located in the frequency bands 54-72 MHz, 76-88 MHz, 174-216 MHz or 470-806 MHz. However, operation within these frequency bands is permitted under other sections of this Part, e.g., Sections 15.231 and 15.241.

(4) According to § 15.209 (b) In the emission table above, the tighter limit applies at the band edges.

TEST EQUIPMENT

Radiated Emission below 1GHz / 966Chamber_A

Name of Equipment	Manufacturer	Model	Serial Number	Calibration Due
Spectrum Analyzer	Agilent	E4446A	MY46180323	04/24/2012
EMI Receiver	ROHDE & SCHWARZ	ESCI	100221	04/24/2012
Bi-log Antenna	SCHWARZBECK	VULB 9168	9168-249	10/03/2012
Broad-Band Horn Antenna	SCHWARZBECK	BBHA 9120 D	9120D-778	09/05/2012
Pre-Amplifier	Agilent	8449B	3008A01471	07/24/2012
Pre-Amplifier	HP	8447F	2944A03748	09/18/2012
LOOP Antenna	EMCO	6502	8905-2356	06/10/2012
Band Reject Notch Filter	Micro-Tronics	BRM05702-01	009	N.C.R

Remark: 1. Each piece of equipment is scheduled for calibration once a year.
2. N.C.R = No Calibration Request.



Radiated Emission above 1GHz / 966Chamber_B

Name of Equipment	Manufacture	Model	Serial Number	Calibration Due
Spectrum Analyzer	Agilent	E4446A	MY43360132	06/19/2012
EMI Receiver	ROHDE & SCHWARZ	ESCI	101131	01/13/2012
Broadband Hybrid Bi-Log Antenna	Sunol Sciences	JB1	A100209-4	10/05/2012
Double-Ridged Waveguide Horn	ETS-LINDGREN	3117	00078733	12/06/2012
Horn Antenna	COM-POWER	AH-840	03077	12/06/2012
Pre-Amplifier	Agilent	8447D	2944A10052	07/19/2012
Pre-Amplifier	Agilent	8449B	3008A01916	09/18/2012
Notch Filters Band Reject	Micro-Tronics	BRM05702-01	026	N.C.R

Remark: 1. Each piece of equipment is scheduled for calibration once a year.
 2. N.C.R = No Calibration Request.

TEST SETUP

The diagram below shows the test setup that is utilized to make the measurements for emission from below 1GHz.

9kHz ~ 30MHz

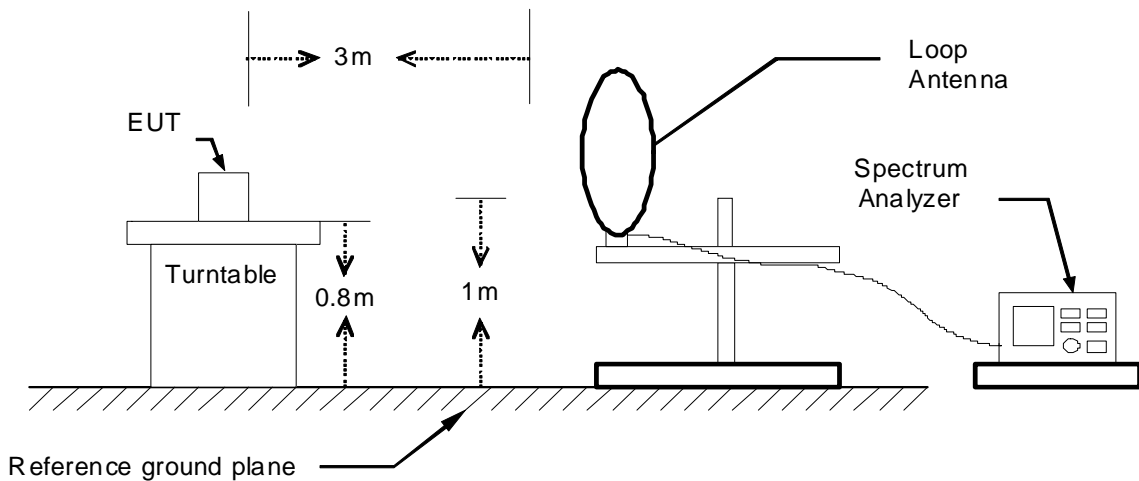



30MHz ~ 1GHz

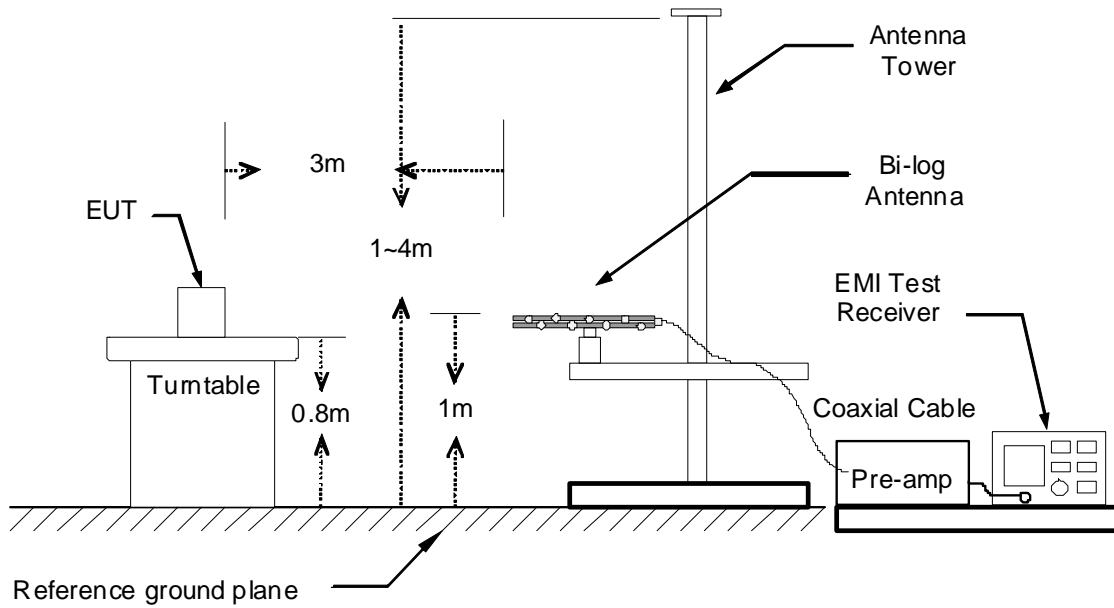

The diagram below shows the test setup that is utilized to make the measurements for emission above 1GHz.

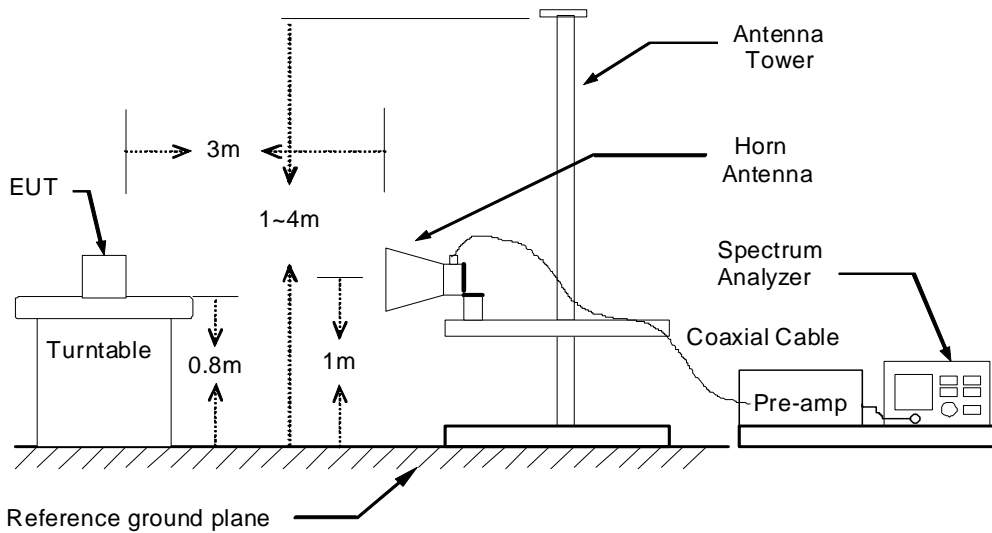



TEST PROCEDURE

1. The EUT was placed on the top of a rotating table 0.8 meters above the ground. The table was rotated 360 degrees to determine the position of the highest radiation.
2. While measuring the radiated emission below 1GHz, the EUT was set 3 meters away from the interference-receiving antenna, which was mounted on the top of a variable-height antenna tower. While measuring the radiated emission above 1GHz, the EUT was set 3 meters away from the interference-receiving antenna.
3. The antenna is a broadband antenna, and its height is varied from one meter to four meters above the ground to determine the maximum value of the field strength. Both horizontal and vertical polarization of the antenna are set to make the measurement.
4. For each suspected emission, the EUT was arranged to its worst case and then the antenna was tuned to heights from 1 meter to 4 meters and the table was turned from 0 degrees to 360 degrees to find the maximum reading.
5. The test-receiver system was set to Peak Detect Function and Specified Bandwidth with Maximum Hold Mode.
6. If the emission level of the EUT in peak mode was 10 dB lower than the limit specified, then testing could be stopped and the peak values of the EUT would be reported. Otherwise the emissions that did not have 10 dB margin would be re-tested one by one using peak, quasi-peak or average method as specified and then reported in a data sheet.

Remark :

1. *The resolution bandwidth and video bandwidth of test receiver/spectrum analyzer is 120 KHz for Peak detection (PK) and Quasi-peak detection (QP) at frequency below 1GHz.*
2. *The resolution bandwidth and video bandwidth of test receiver/spectrum analyzer is 1 MHz for Peak detection and frequency above 1GHz.*
3. *The resolution bandwidth of test receiver/spectrum analyzer is 1 MHz and the video bandwidth is 10 Hz for Average detection (AV) at frequency above 1GHz.*



TEST RESULTS

Below 1 GHz (9kHz ~ 30MHz)

No emission found between lowest internal used/generated frequency to 30MHz.

Below 1 GHz (30MHz ~ 1GHz)

Product Name	802.11g/DRAFT 802.11n WIRELESS LAN PCI-E MINICARD	Test By	Leon Cheng
Test Model	BCM94313HMG2L	Test Date	2011/11/17
Test Mode	IEEE 802.11b TX / CH Low (worst case)	Temp. & Humidity	20.5°C, 65%

966 Chamber_A at 3Meter / Horizontal						
Frequency (MHz)	Reading (dBµV)	Correction Factor (dB/m)	Result (dBµV/m)	Limit (dBµV/m)	Margin (dB)	Remark
167.74	40.21	-9.55	30.65	43.50	-12.85	Peak
192.96	43.88	-11.72	32.16	43.50	-11.34	Peak
232.73	44.28	-11.34	32.94	46.00	-13.06	Peak
278.32	42.77	-9.37	33.40	46.00	-12.60	Peak
709.97	29.03	0.35	29.38	46.00	-16.62	Peak
801.15	32.82	2.02	34.84	46.00	-11.16	Peak

966 Chamber_A at 3Meter / Vertical						
Frequency (MHz)	Reading (dBµV)	Correction Factor (dB/m)	Result (dBµV/m)	Limit (dBµV/m)	Margin (dB)	Remark
139.61	37.09	-10.11	26.98	43.50	-16.52	Peak
278.32	33.26	-9.37	23.89	46.00	-22.11	Peak
474.26	37.11	-4.35	32.76	46.00	-13.24	Peak
747.80	32.97	0.97	33.94	46.00	-12.06	Peak
785.63	36.99	1.72	38.70	46.00	-7.30	Peak
798.24	35.87	1.97	37.83	46.00	-8.17	Peak

Remark:

1. Quasi-peak test would be performed if the peak result were greater than the quasi-peak limit.
2. Data of measurement within this frequency range shown " --- " in the table above means the reading of emissions are attenuated more than 20dB below the permissible limits or the field strength is too small to be measured.
3. Correction Factor (dB/m) = Antenna Factor (dB/m) + Cable Loss (dB) – PreAmp.Gain (dB)
4. Result (dBµV/m) = Reading (dBµV) + Correction Factor (dB/m)
5. Margin (dB) = Remark result (dBµV/m) - Quasi-peak limit (dBµV/m).



TX Above 1 GHz

Product Name	802.11g/DRAFT 802.11n WIRELESS LAN PCI-E MINICARD	Test By	Leon Cheng
Test Model	BCM94313HMG2L	Test Date	2011/12/14
Test Mode	IEEE 802.11b TX / CH Low	TEMP & Humidity	21.3°C, 62%

966 Chamber_B at 3Meter / Horizontal									
Frequency (MHz)	Reading-PK (dBuV)	Reading-AV (dBuV)	Correction Factor (dB/m)	Result-PK (dBuV/m)	Result-AV (dBuV/m)	Limit-PK (dBuV/m)	Limit-AV (dBuV/m)	Margin (dB)	Remark
1234.00	54.70	---	-3.13	51.57	---	74.00	54.00	-2.43	Peak
1572.00	53.70	---	-1.62	52.07	---	74.00	54.00	-1.93	Peak
3150.00	42.23	---	5.57	47.80	---	74.00	54.00	-6.20	Peak
4320.00	40.91	---	8.08	48.99	---	74.00	54.00	-5.01	Peak
4980.00	40.04	---	9.87	49.91	---	74.00	54.00	-4.09	Peak

966 Chamber_B at 3Meter / Vertical									
Frequency (MHz)	Reading-PK (dBuV)	Reading-AV (dBuV)	Correction Factor (dB/m)	Result-PK (dBuV/m)	Result-AV (dBuV/m)	Limit-PK (dBuV/m)	Limit-AV (dBuV/m)	Margin (dB)	Remark
1192.00	54.06	---	-3.26	50.80	---	74.00	54.00	-3.20	Peak
1468.00	53.74	---	-2.37	51.37	---	74.00	54.00	-2.63	Peak
3255.00	42.23	---	5.69	47.91	---	74.00	54.00	-6.09	Peak
3930.00	41.46	---	6.85	48.31	---	74.00	54.00	-5.69	Peak
4470.00	41.04	---	8.59	49.63	---	74.00	54.00	-4.37	Peak

Remark:

1. Measuring frequencies from 1 GHz to the 10th harmonic of highest fundamental frequency.
2. Average test would be performed if the peak result were greater than the average limit.
3. Data of measurement within this frequency range shown " --- " in the table above means the reading of emissions are attenuated more than 20dB below the permissible limits or the field strength is too small to be measured.
4. Measurements above show only up to 6 maximum emissions noted, or would be lesser, with " N/A " remark, if no specific emissions from the EUT are recorded (ie: margin>20dB from the applicable limit) and considered that's already beyond the background noise floor.
5. Result = Reading + Correction Factor
Margin = Result - Limit
Remark Peak = Result(PK) - Limit(AV)
Remark AVG = Result(AV) - Limit(AV)



Product Name	802.11g/DRAFT 802.11n WIRELESS LAN PCI-E MINICARD	Test By	Leon Cheng
Test Model	BCM94313HMG2L	Test Date	2011/12/14
Test Mode	IEEE 802.11b TX / CH Middle	TEMP & Humidity	21.3°C, 62%

966 Chamber_B at 3Meter / Horizontal									
Frequency (MHz)	Reading-PK (dBuV)	Reading-AV (dBuV)	Correction Factor (dB/m)	Result-PK (dBuV/m)	Result-AV (dBuV/m)	Limit-PK (dBuV/m)	Limit-AV (dBuV/m)	Margin (dB)	Remark
1308.00	55.28	---	-2.89	52.39	---	74.00	54.00	-1.61	Peak
1610.00	53.99	---	-1.28	52.70	---	74.00	54.00	-1.30	Peak
3180.00	42.31	---	5.60	47.92	---	74.00	54.00	-6.08	Peak
4170.00	40.72	---	7.57	48.30	---	74.00	54.00	-5.70	Peak
4860.00	40.59	---	9.58	50.17	---	74.00	54.00	-3.83	Peak

966 Chamber_B at 3Meter / Vertical									
Frequency (MHz)	Reading-PK (dBuV)	Reading-AV (dBuV)	Correction Factor (dB/m)	Result-PK (dBuV/m)	Result-AV (dBuV/m)	Limit-PK (dBuV/m)	Limit-AV (dBuV/m)	Margin (dB)	Remark
1384.00	55.03	---	-2.64	52.39	---	74.00	54.00	-1.61	Peak
1606.00	53.77	---	-1.32	52.46	---	74.00	54.00	-1.54	Peak
3150.00	41.81	---	5.57	47.38	---	74.00	54.00	-6.62	Peak
4395.00	40.91	---	8.34	49.24	---	74.00	54.00	-4.76	Peak
5055.00	40.73	---	10.01	50.75	---	74.00	54.00	-3.25	Peak

Remark:

1. Measuring frequencies from 1 GHz to the 10th harmonic of highest fundamental frequency.
2. Average test would be performed if the peak result were greater than the average limit.
3. Data of measurement within this frequency range shown " --- " in the table above means the reading of emissions are attenuated more than 20dB below the permissible limits or the field strength is too small to be measured.
4. Measurements above show only up to 6 maximum emissions noted, or would be lesser, with " N/A " remark, if no specific emissions from the EUT are recorded (ie: margin>20dB from the applicable limit) and considered that's already beyond the background noise floor.
5. Result = Reading + Correction Factor
Margin = Result - Limit
Remark Peak = Result(PK) - Limit(AV)
Remark AVG = Result(AV) - Limit(AV)



Product Name	802.11g/DRAFT 802.11n WIRELESS LAN PCI-E MINICARD	Test By	Leon Cheng
Test Model	BCM94313HMG2L	Test Date	2011/12/14
Test Mode	IEEE 802.11b TX / CH High	TEMP & Humidity	21.3°C, 62%

966 Chamber_B at 3Meter / Horizontal									
Frequency (MHz)	Reading-PK (dBuV)	Reading-AV (dBuV)	Correction Factor (dB/m)	Result-PK (dBuV/m)	Result-AV (dBuV/m)	Limit-PK (dBuV/m)	Limit-AV (dBuV/m)	Margin (dB)	Remark
1226.00	55.62	---	-3.15	52.46	---	74.00	54.00	-1.54	Peak
1576.00	54.44	---	-1.59	52.85	---	74.00	54.00	-1.15	Peak
3315.00	41.73	---	5.75	47.48	---	74.00	54.00	-6.52	Peak
4230.00	41.36	---	7.78	49.14	---	74.00	54.00	-4.86	Peak
4920.00	39.92	---	9.72	49.64	---	74.00	54.00	-4.36	Peak

966 Chamber_B at 3Meter / Vertical									
Frequency (MHz)	Reading-PK (dBuV)	Reading-AV (dBuV)	Correction Factor (dB/m)	Result-PK (dBuV/m)	Result-AV (dBuV/m)	Limit-PK (dBuV/m)	Limit-AV (dBuV/m)	Margin (dB)	Remark
1124.00	55.45	---	-3.48	51.97	---	74.00	54.00	-2.03	Peak
1376.00	54.20	---	-2.67	51.53	---	74.00	54.00	-2.47	Peak
3240.00	41.63	---	5.67	47.30	---	74.00	54.00	-6.70	Peak
3795.00	41.38	---	6.57	47.95	---	74.00	54.00	-6.05	Peak
4905.00	39.83	---	9.69	49.52	---	74.00	54.00	-4.48	Peak

Remark:

1. Measuring frequencies from 1 GHz to the 10th harmonic of highest fundamental frequency.
2. Average test would be performed if the peak result were greater than the average limit.
3. Data of measurement within this frequency range shown " --- " in the table above means the reading of emissions are attenuated more than 20dB below the permissible limits or the field strength is too small to be measured.
4. Measurements above show only up to 6 maximum emissions noted, or would be lesser, with " N/A " remark, if no specific emissions from the EUT are recorded (ie: margin>20dB from the applicable limit) and considered that's already beyond the background noise floor.
5. Result = Reading + Correction Factor
Margin = Result - Limit
Remark Peak = Result(PK) - Limit(AV)
Remark AVG = Result(AV) - Limit(AV)



Product Name	802.11g/DRAFT 802.11n WIRELESS LAN PCI-E MINICARD	Test By	Leon Cheng
Test Model	BCM94313HMG2L	Test Date	2011/12/14
Test Mode	IEEE 802.11g TX / CH Low	TEMP & Humidity	21.3°C, 62%

966 Chamber_B at 3Meter / Horizontal									
Frequency (MHz)	Reading-PK (dBuV)	Reading-AV (dBuV)	Correction Factor (dB/m)	Result-PK (dBuV/m)	Result-AV (dBuV/m)	Limit-PK (dBuV/m)	Limit-AV (dBuV/m)	Margin (dB)	Remark
1098.00	54.79	---	-3.56	51.22	---	74.00	54.00	-2.78	Peak
1486.00	54.01	---	-2.32	51.70	---	74.00	54.00	-2.30	Peak
3210.00	42.25	---	5.64	47.89	---	74.00	54.00	-6.11	Peak
4545.00	40.52	---	8.80	49.32	---	74.00	54.00	-4.68	Peak
4935.00	40.42	---	9.76	50.18	---	74.00	54.00	-3.82	Peak

966 Chamber_B at 3Meter / Vertical									
Frequency (MHz)	Reading-PK (dBuV)	Reading-AV (dBuV)	Correction Factor (dB/m)	Result-PK (dBuV/m)	Result-AV (dBuV/m)	Limit-PK (dBuV/m)	Limit-AV (dBuV/m)	Margin (dB)	Remark
1182.00	54.28	---	-3.29	50.98	---	74.00	54.00	-3.02	Peak
1496.00	54.07	---	-2.28	51.79	---	74.00	54.00	-2.21	Peak
3180.00	41.87	---	5.60	47.47	---	74.00	54.00	-6.53	Peak
4110.00	40.52	---	7.37	47.89	---	74.00	54.00	-6.11	Peak
4995.00	41.51	---	9.91	51.41	---	74.00	54.00	-2.59	Peak

Remark:

1. Measuring frequencies from 1 GHz to the 10th harmonic of highest fundamental frequency.
2. Average test would be performed if the peak result were greater than the average limit.
3. Data of measurement within this frequency range shown " --- " in the table above means the reading of emissions are attenuated more than 20dB below the permissible limits or the field strength is too small to be measured.
4. Measurements above show only up to 6 maximum emissions noted, or would be lesser, with " N/A " remark, if no specific emissions from the EUT are recorded (ie: margin>20dB from the applicable limit) and considered that's already beyond the background noise floor.
5. Result = Reading + Correction Factor
Margin = Result - Limit
Remark Peak = Result(PK) - Limit(AV)
Remark AVG = Result(AV) - Limit(AV)



Product Name	802.11g/DRAFT 802.11n WIRELESS LAN PCI-E MINICARD	Test By	Leon Cheng
Test Model	BCM94313HMG2L	Test Date	2011/12/14
Test Mode	IEEE 802.11g TX / CH Middle	TEMP & Humidity	21.3°C, 62%

966 Chamber_B at 3Meter / Horizontal									
Frequency (MHz)	Reading-PK (dBuV)	Reading-AV (dBuV)	Correction Factor (dB/m)	Result-PK (dBuV/m)	Result-AV (dBuV/m)	Limit-PK (dBuV/m)	Limit-AV (dBuV/m)	Margin (dB)	Remark
1328.00	54.41	---	-2.82	51.58	---	74.00	54.00	-2.42	Peak
1554.00	53.84	---	-1.79	52.05	---	74.00	54.00	-1.95	Peak
3135.00	41.85	---	5.56	47.41	---	74.00	54.00	-6.59	Peak
4275.00	40.79	---	7.93	48.72	---	74.00	54.00	-5.28	Peak
4980.00	39.88	---	9.87	49.75	---	74.00	54.00	-4.25	Peak

966 Chamber_B at 3Meter / Vertical									
Frequency (MHz)	Reading-PK (dBuV)	Reading-AV (dBuV)	Correction Factor (dB/m)	Result-PK (dBuV/m)	Result-AV (dBuV/m)	Limit-PK (dBuV/m)	Limit-AV (dBuV/m)	Margin (dB)	Remark
1296.00	54.74	---	-2.93	51.81	---	74.00	54.00	-2.19	Peak
1558.00	54.07	---	-1.75	52.32	---	74.00	54.00	-1.68	Peak
3135.00	42.07	---	5.56	47.63	---	74.00	54.00	-6.37	Peak
4380.00	39.93	---	8.28	48.22	---	74.00	54.00	-5.78	Peak
4980.00	40.49	---	9.87	50.36	---	74.00	54.00	-3.64	Peak

Remark:

1. Measuring frequencies from 1 GHz to the 10th harmonic of highest fundamental frequency.
2. Average test would be performed if the peak result were greater than the average limit.
3. Data of measurement within this frequency range shown " --- " in the table above means the reading of emissions are attenuated more than 20dB below the permissible limits or the field strength is too small to be measured.
4. Measurements above show only up to 6 maximum emissions noted, or would be lesser, with " N/A " remark, if no specific emissions from the EUT are recorded (ie: margin>20dB from the applicable limit) and considered that's already beyond the background noise floor.
5. Result = Reading + Correction Factor
 Margin = Result - Limit
 Remark Peak = Result(PK) - Limit(AV)
 Remark AVG = Result(AV) - Limit(AV)



Product Name	802.11g/DRAFT 802.11n WIRELESS LAN PCI-E MINICARD	Test By	Leon Cheng
Test Model	BCM94313HMG2L	Test Date	2011/12/14
Test Mode	IEEE 802.11g TX / CH High	TEMP & Humidity	21.3°C, 62%

966 Chamber_B at 3Meter / Horizontal

Frequency (MHz)	Reading-PK (dBuV)	Reading-AV (dBuV)	Correction Factor (dB/m)	Result-PK (dBuV/m)	Result-AV (dBuV/m)	Limit-PK (dBuV/m)	Limit-AV (dBuV/m)	Margin (dB)	Remark
1076.00	54.74	---	-3.64	51.10	---	74.00	54.00	-2.90	Peak
1552.00	54.28	---	-1.80	52.47	---	74.00	54.00	-1.53	Peak
3165.00	42.18	---	5.59	47.77	---	74.00	54.00	-6.23	Peak
4035.00	41.39	---	7.12	48.50	---	74.00	54.00	-5.50	Peak
4980.00	40.31	---	9.87	50.18	---	74.00	54.00	-3.82	Peak

966 Chamber_B at 3Meter / Vertical

Frequency (MHz)	Reading-PK (dBuV)	Reading-AV (dBuV)	Correction Factor (dB/m)	Result-PK (dBuV/m)	Result-AV (dBuV/m)	Limit-PK (dBuV/m)	Limit-AV (dBuV/m)	Margin (dB)	Remark
1146.00	54.75	---	-3.41	51.34	---	74.00	54.00	-2.66	Peak
1570.00	54.04	---	-1.64	52.40	---	74.00	54.00	-1.60	Peak
3180.00	42.00	---	5.60	47.61	---	74.00	54.00	-6.39	Peak
4470.00	40.73	---	8.59	49.32	---	74.00	54.00	-4.68	Peak
4980.00	41.20	---	9.87	51.07	---	74.00	54.00	-2.93	Peak

Remark:

1. Measuring frequencies from 1 GHz to the 10th harmonic of highest fundamental frequency.
2. Average test would be performed if the peak result were greater than the average limit.
3. Data of measurement within this frequency range shown " --- " in the table above means the reading of emissions are attenuated more than 20dB below the permissible limits or the field strength is too small to be measured.
4. Measurements above show only up to 6 maximum emissions noted, or would be lesser, with " N/A " remark, if no specific emissions from the EUT are recorded (ie: margin>20dB from the applicable limit) and considered that's already beyond the background noise floor.
5. Result = Reading + Correction Factor
Margin = Result - Limit
Remark Peak = Result(PK) - Limit(AV)
Remark AVG = Result(AV) - Limit(AV)



Restricted Band Edges

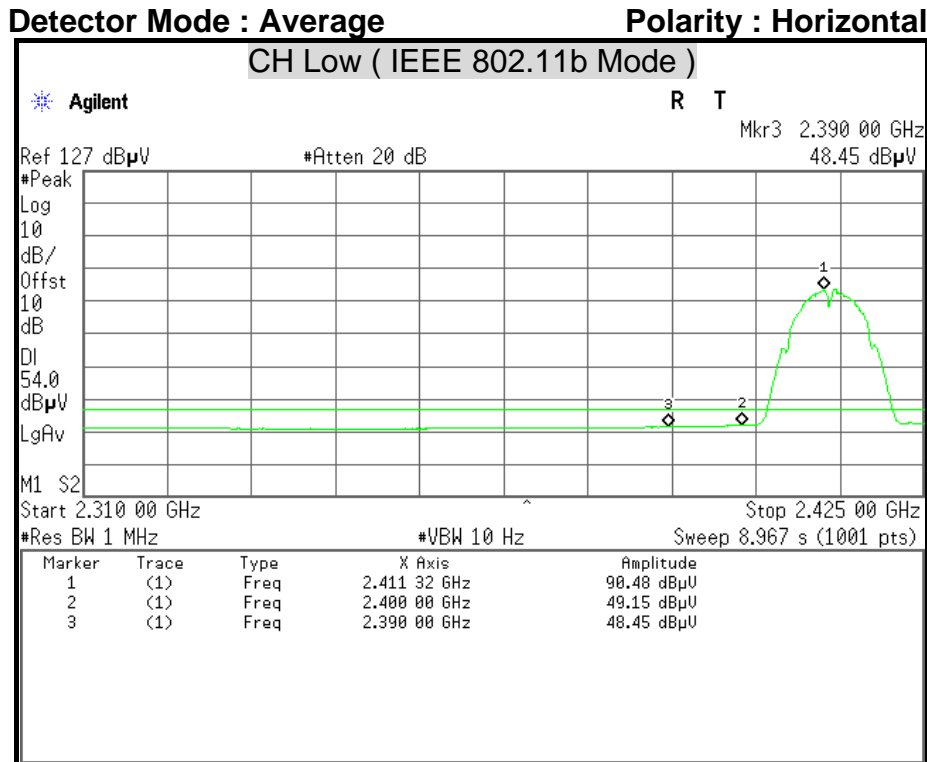
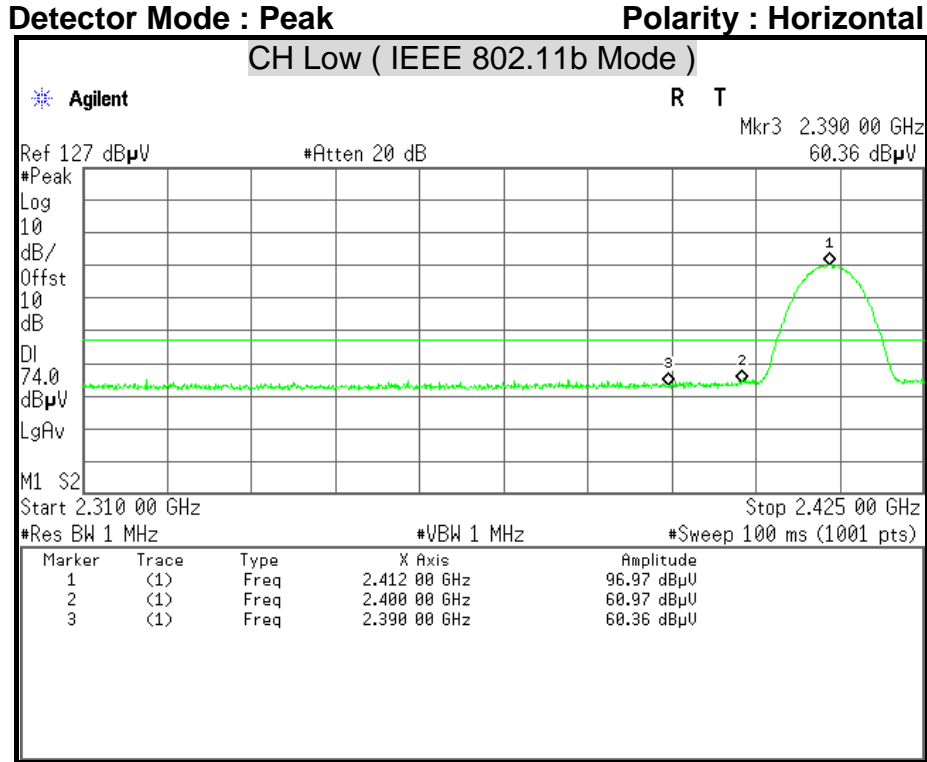



Detector Mode : Peak

Polarity : Vertical

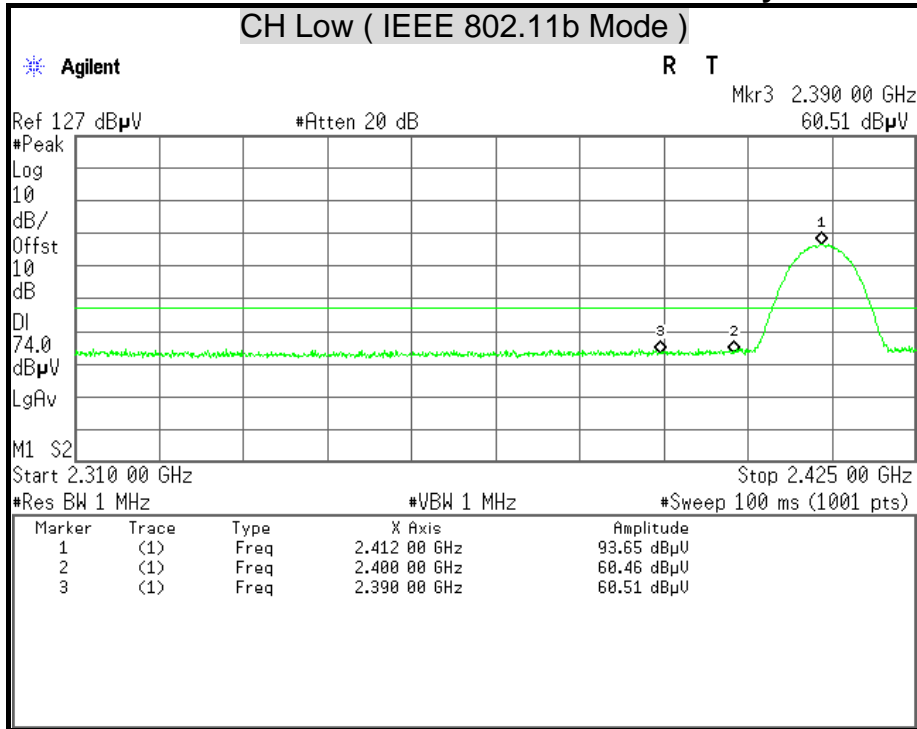

Detector Mode : Average

Polarity : Vertical

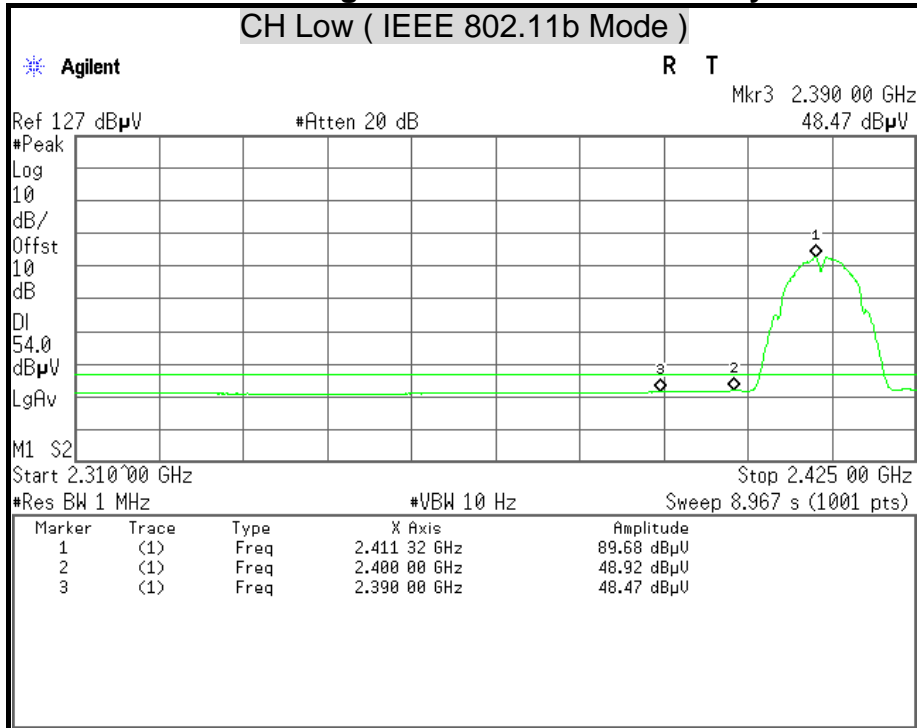



Detector Mode : Peak

Polarity : Horizontal

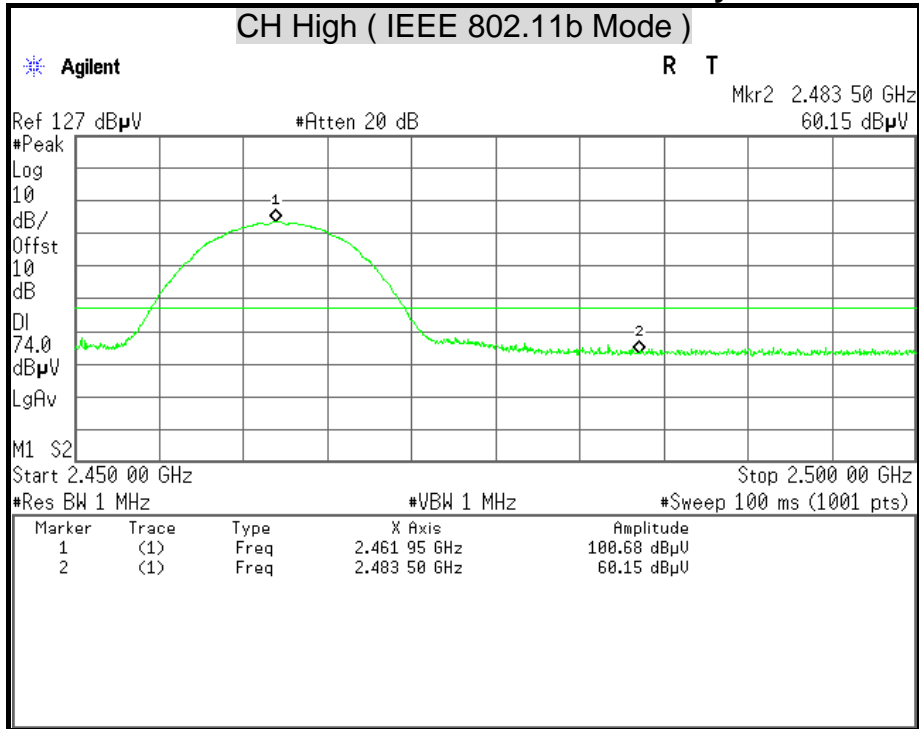

Detector Mode : Average

Polarity : Horizontal

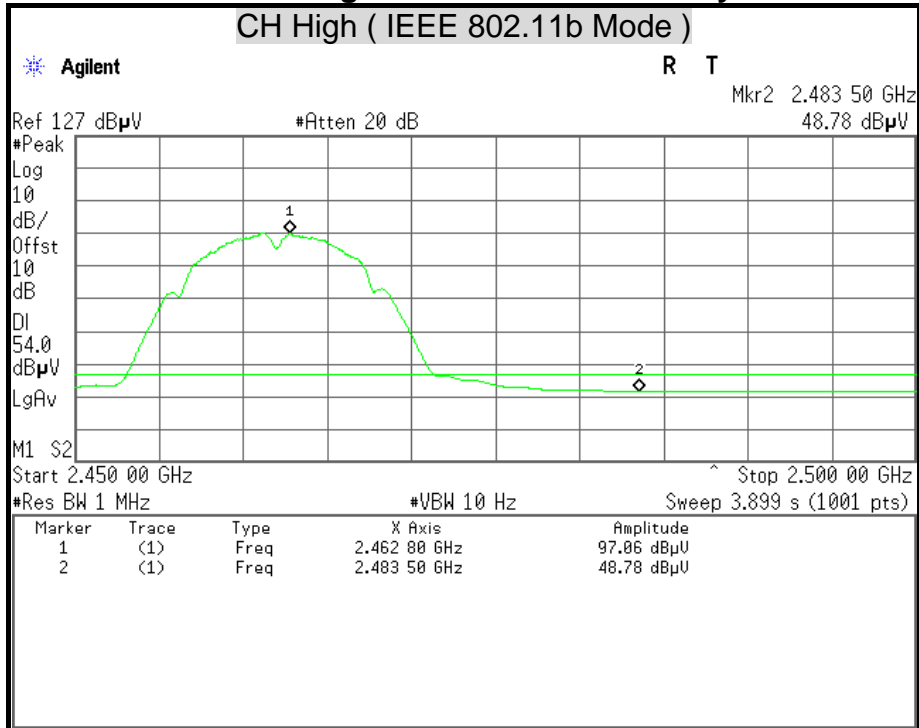



Detector Mode : Peak

Polarity : Vertical

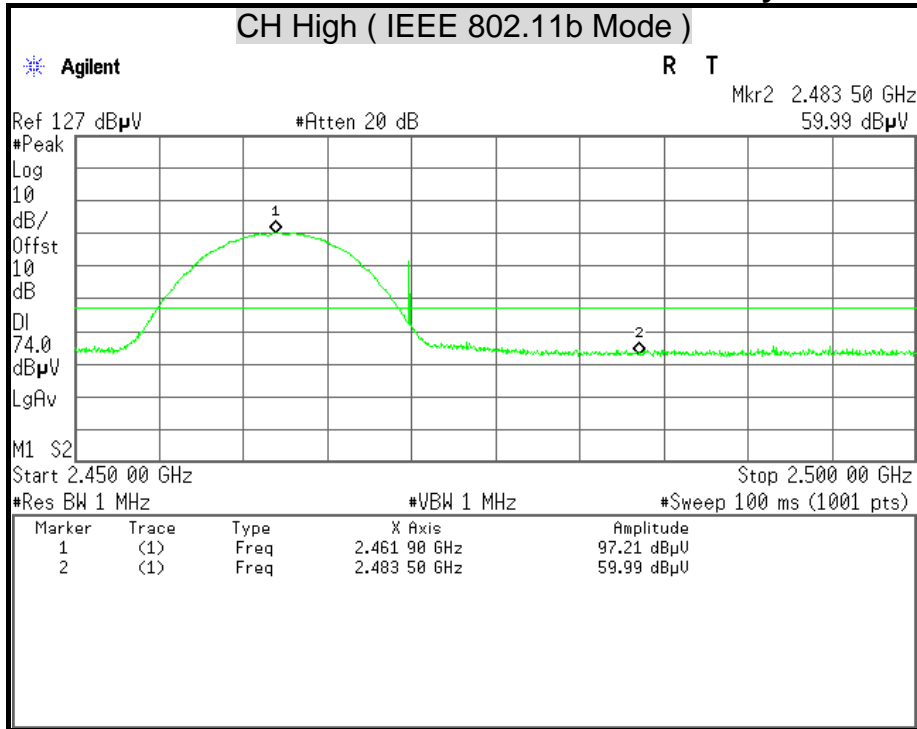

Detector Mode : Average

Polarity : Vertical

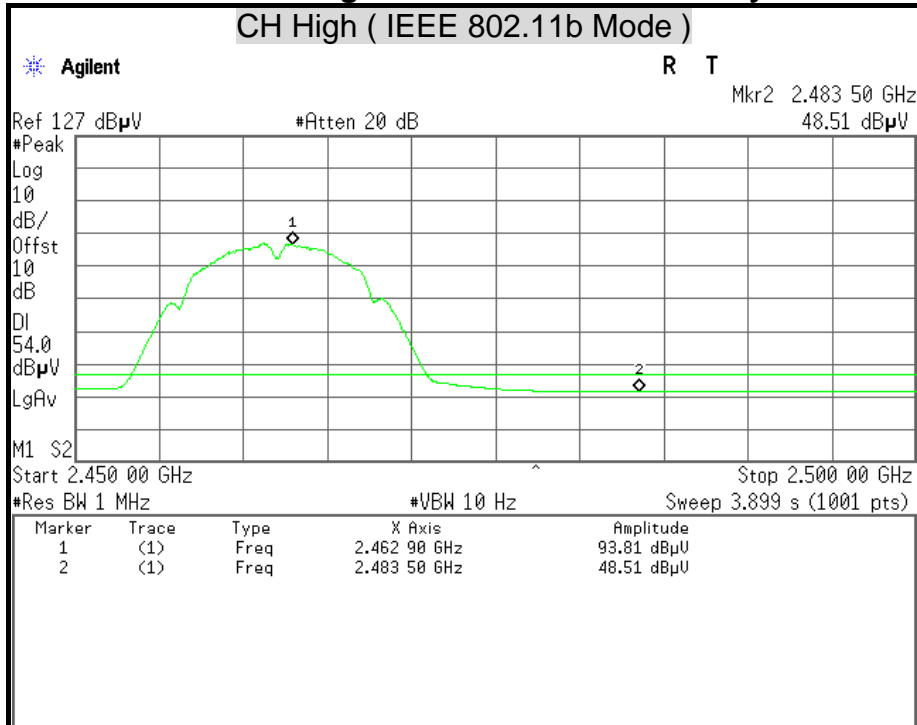



Detector Mode : Peak

Polarity : Horizontal

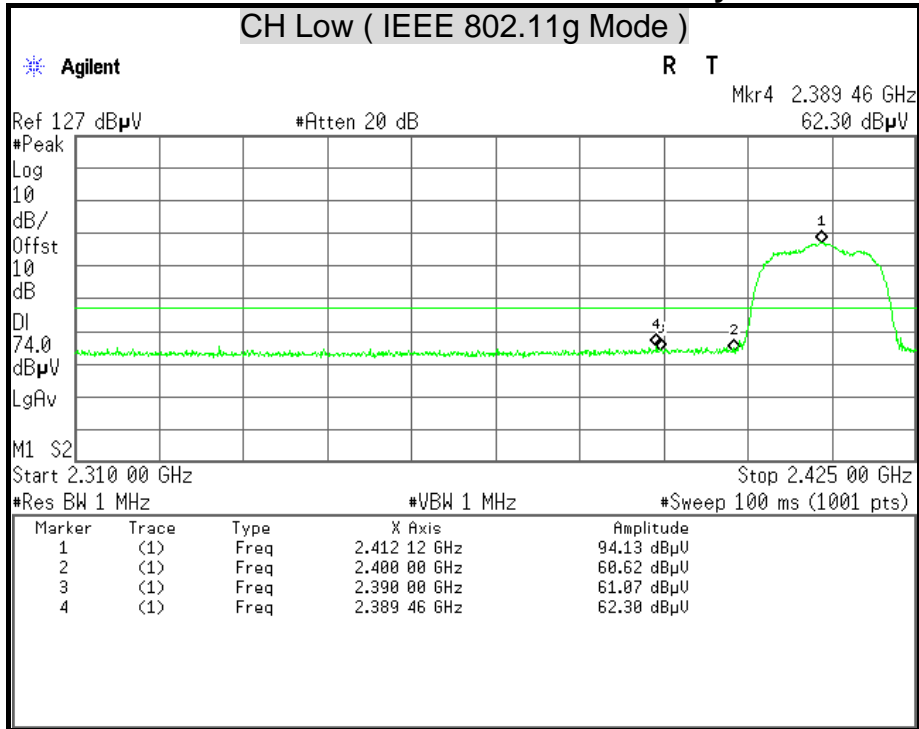

Detector Mode : Average

Polarity : Horizontal

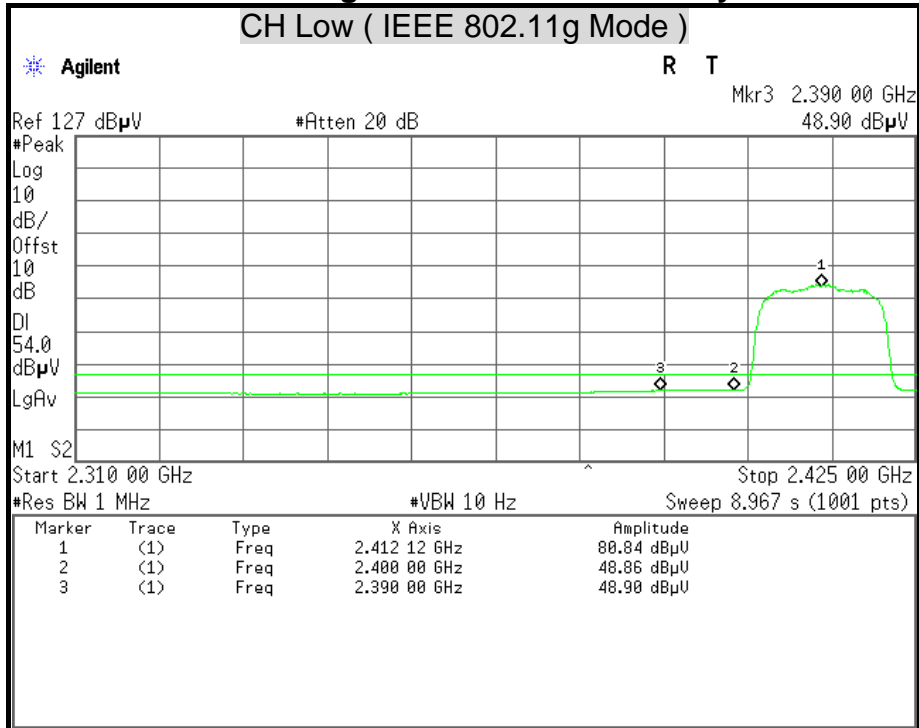



Detector Mode : Peak

Polarity : Vertical

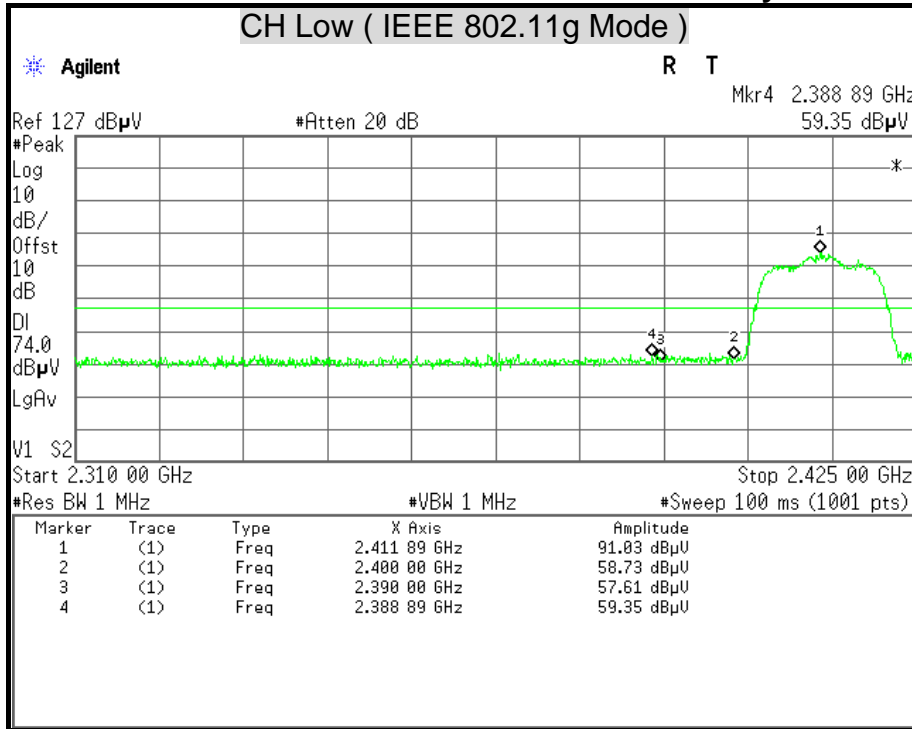

Detector Mode : Average

Polarity : Vertical

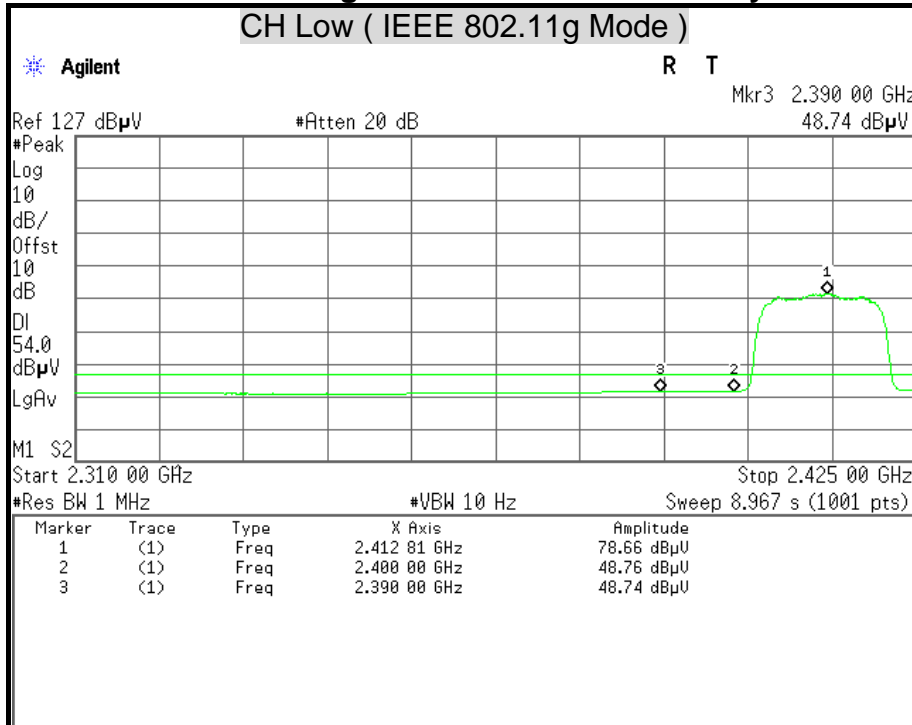



Detector Mode : Peak

Polarity : Horizontal

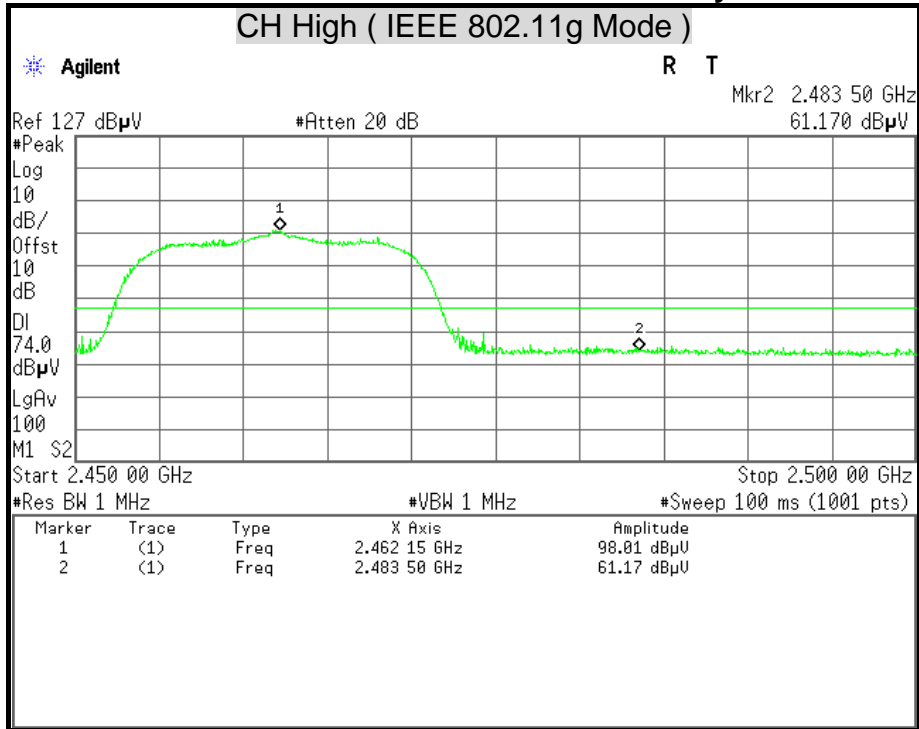

Detector Mode : Average

Polarity : Horizontal

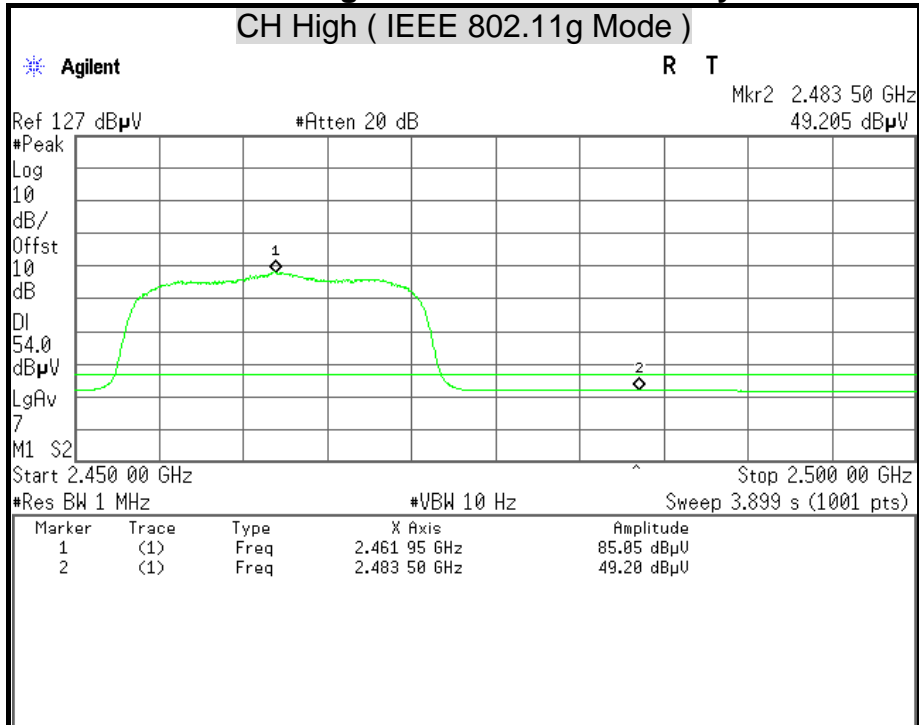



Detector Mode : Peak

Polarity : Vertical

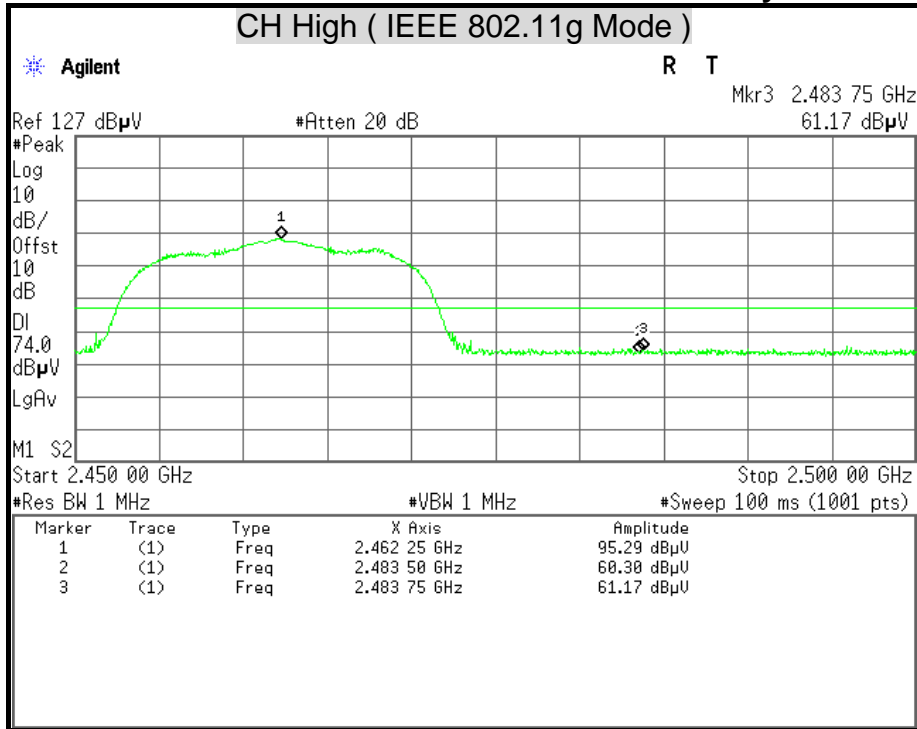

Detector Mode : Average

Polarity : Vertical

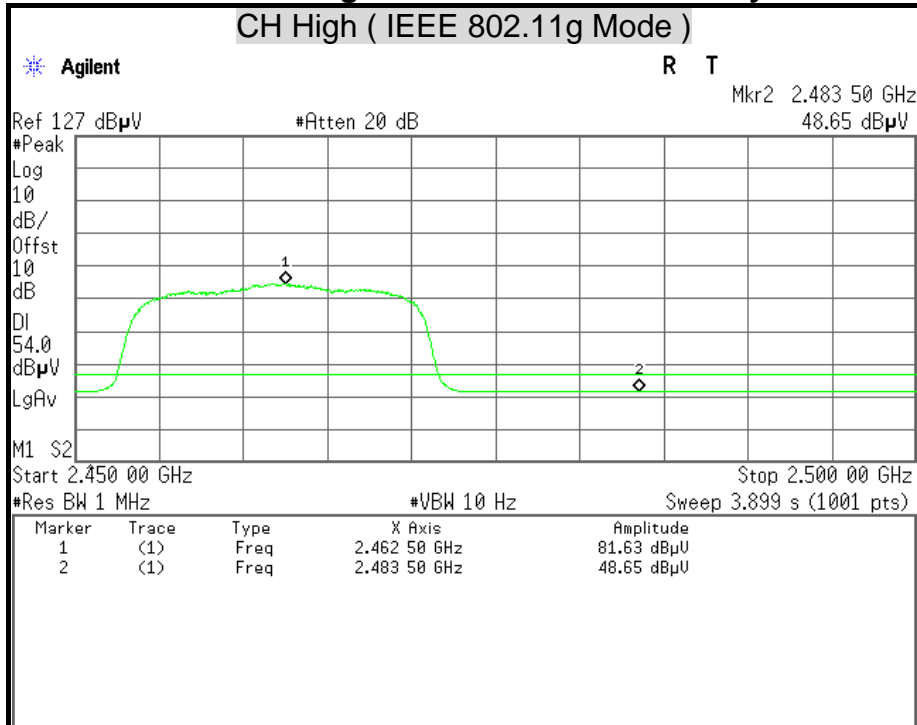



APPENDIX SETUP PHOTOS

RADIATED EMISSION SETUP

