

Antenna Regulatory Information

<ul style="list-style-type: none"> • Product type 	<ul style="list-style-type: none"> • WLAN antenna
<ul style="list-style-type: none"> • Model number 	<ul style="list-style-type: none"> • DELL Greenland (EAX20)
<ul style="list-style-type: none"> • Revision 	<ul style="list-style-type: none"> •
<ul style="list-style-type: none"> • Manufacturer Part No. : Main /Mimo/ Aux • S16002-L-1 • S16002-R-1 • S03014-561-W-SS-IP • S03014-636-B-SS-IP • S03014-633-S-SS-IP 	<ul style="list-style-type: none"> • Description • LCD Left Side • LCD Right Side • Hinge white cable • Hinge Black cable • Hinge Gray cable
<ul style="list-style-type: none"> • Dell Part No. : Main/Mimo/ Aux • DS330007Z0L • DC330008A0L • DC330008H4L • DC330008I4L • DC33000A02L 	<ul style="list-style-type: none"> • Description • LCD Left Side • LCD Right Side • Hinge white cable • Hinge Black cable • Hinge Gray cable

Amphenol

Shanghai Amphenol Airwave Communication Electronics Co., LTD

No. 88 Lai Ting S. Rd, Jiu Ting, Song Jiang,

Shanghai, China (201615)

1. Specifications

Antenna Specifications

Antenna Type (Material, Technology)	PCB Antenna
Antenna Model Number	EAX20 (DELL Greenland)
Operating Frequency Range(s)	2.4GHz ~ 2.5GHz and 4.9GHz ~ 5.9GHz
Peak Gain (802.11b/g / 2.4GHz Band) (dBi)	1.66 dBi
Peak Gain (802.11a / 5GHz Band) (dBi)	2.36 dBi
Radio Connector Type	IPEX
Mid-Line Connector Type (If Applicable)	SSMCX

Remark: Peak Gains include all system losses (connector, cable, etc)

Cable Specifications

Cable Parameters	Main			Mimo		
	LCD Side	Base Side	Total	LCD Side	Base Side	Total
Length (mm)	270	629	899	270	629	899
Loss (Including Connectors) (dB, 2.4GHz / 5GHz)			2.1/3.7			2.1/3.7
Description (Color, Diameter, Manufacturer)	Color: White OD: 1.32~1.37 mm Vendor: GBE			Color: Black OD: 1.32~1.37 mm Vendor: GBE		

Cable Parameters	Aux		
	LCD Side	Base Side	Total
Length (mm)	380	608	988
Loss (Including Connectors) (dB, 2.4GHz / 5GHz)			2.1/3.7
Description (Color, Diameter, Manufacturer)	Color: White OD: 1.32~1.37 mm Vendor: GBE		

REVISIONS			
REV	DESCRIPTION	SIGNATURE AND DATE	
		CHK	ENGR

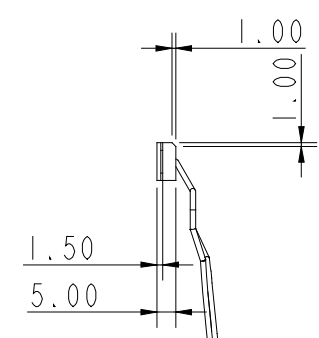
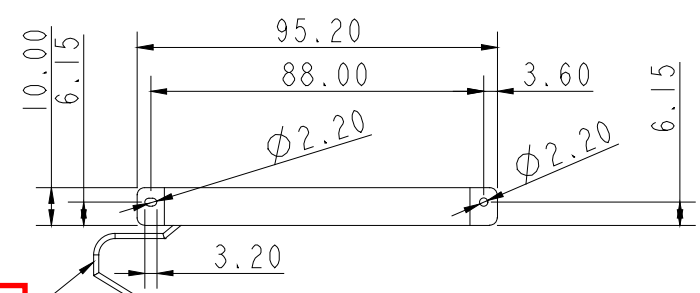

ϕ 1.37mm
 L=380mm

MOLEX SSMCX-PC 73415-4680 PLUG

BLACK CABLE

ITEM	PART NUMBER	PART NAME	VENDOR
1	DC330007U0L	ANTENNA ZKI WDAN-DCEAX202-DF R	Foxconn
2	DC330007X0L	ANTENNA ZKI HMT02-R	Hitachi
3	DC330007Y0L	ANTENNA ZKI CAN4313 516 022501B R	Yageo
4	DC330008A0L	ANTENNA ZKI SI6002-R-1 R	Amphenol
5	DC330008C0L	ANTENNA ZKI 81.EDQ15.002 R	WNC

SCALE 0.500

RANGE	TOLERANCE	MODEL			PART NO.			REMARK				
201 ABOVE	0.3	SCALE	0.17	UNIT	MM	SIGNATURE	NAME	DATE	Compal Electronics, Inc.			
101 - 200	\pm 0.25	TOL.	1 PLC	2 PLC	ANGLE	DRN BY.	A	13-Sep-05	TITLE			
51 - 100	\pm 0.2					CHK BY.			EAX20_ANTENNA_DUALBAND_5R			
31 - 50	\pm 0.15					PRJ ENGR						
30 mm BELOW	0.1	MATERIAL:				ENGR APPRO						
		FIRST APPLICATION				FINISH:	SIZE	SHEET	1 OF 1	DRAWING NO.	REV	VERSION
		DATE	TOOLING NO.	REMARK		A3				0	12	

PROPRIETARY NOTE: THIS SHEET OF ENGINEERING DRAWINGS AND SPECIFICATIONS CONTAINS CONFIDENTIAL, TRADE SECRET, AND OTHER PROPRIETARY INFORMATION OF DELL INC. ("DELL"). THIS DOCUMENT MAY NOT BE TRANSFERRED OR COPIED WITHOUT THE EXPRESS WRITTEN AUTHORIZATION OF DELL. IN ADDITION, NEITHER THIS SHEET NOR THE INFORMATION IT CONTAINS MAY BE USED BY OR DISCLOSED TO ANY THIRD PARTY WITHOUT DELL'S EXPRESS WRITTEN CONSENT.

REVISIONS			
REV	DESCRIPTION	SIGNATURE AND DATE	
		CHK	ENGR

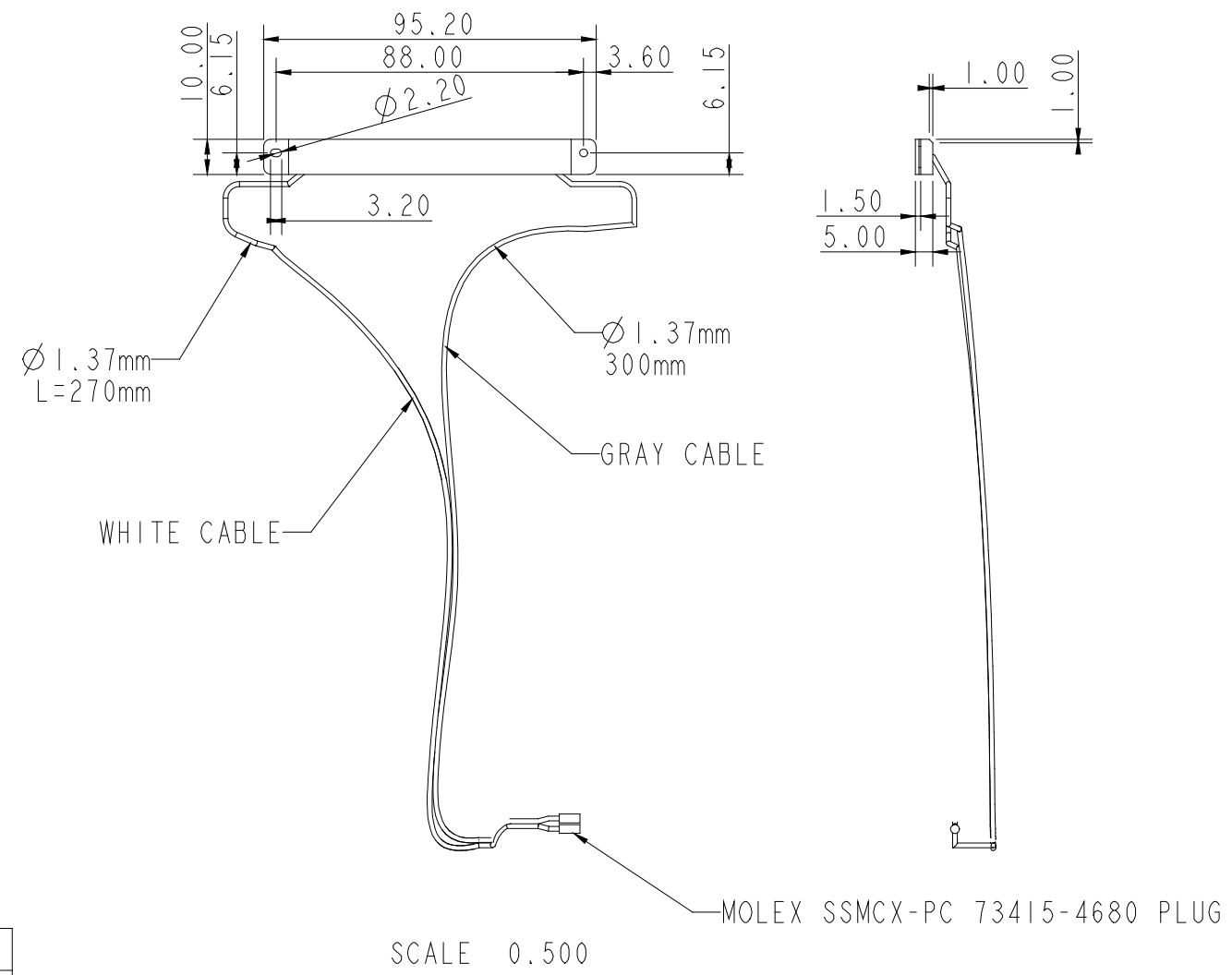

ITEM	PART NUMBER	PART NAME	VENDOR
1	DC330007T0L	ANTENNA ZKI WDAN-DCEAX201-DF L	Foxconn
2	DC330007V0L	ANTENNA ZKI HMT02-L	Hitachi
3	DC330007W0L	ANTENNA ZKI CAN4313 516 012501B L	Yageo
4	DC330007Z0L	ANTENNA ZKI S16002-L-1 L	Amphenol
5	DC330008B0L	ANTENNA ZKI 81.EDQ15.001 L	WNC

RANGE	TOLERANCE	MODEL			PART NO.			REMARK			
201 ABOVE	0.3	SCALE	0.17	UNIT	MM	SIGNATURE	NAME	DATE	Compal Electronics, Inc.		
101 - 200	± 0.25	TOL.	1 PLC	2 PLC	ANGLE	DRN BY.	A	13-Sep-05	TITLE		
51 - 100	± 0.2	+				CHK BY.			EAX20_ANTENNA_DUALBAND		
31 - 50	± 0.15	-				PRJ ENGR					
30 mm BELOW	0.1	MATERIAL:				ENGR APPRO					
		FIRST APPLICATION				FINISH:	SIZE	SHEET	1 OF 1	DRAWING NO.	
		DATE	TOOLING NO.	REMARK		A3				REV	VERSION
										0	12

PROPRIETARY NOTE: THIS SHEET OF ENGINEERING DRAWINGS AND SPECIFICATIONS CONTAINS CONFIDENTIAL, TRADE SECRET, AND OTHER PROPRIETARY INFORMATION OF DELL INC. ("DELL"). THIS DOCUMENT MAY NOT BE TRANSFERRED OR COPIED WITHOUT THE EXPRESS WRITTEN AUTHORIZATION OF DELL. IN ADDITION, NEITHER THIS SHEET NOR THE INFORMATION IT CONTAINS MAY BE USED BY OR DISCLOSED TO ANY THIRD PARTY WITHOUT DELL'S EXPRESS WRITTEN CONSENT.

REVISIONS		SIGNATURE	AND DATE
REV	DESCRIPTION	CHK	ENGR

- INTERPRET DIMENSIONS PER ASME Y14.5M-1994.
- THE MATERIALS AND MANUFACTURING METHODS USED IN THE FABRICATION OF THIS ASSEMBLY MUST COMPLY WITH DELL SPECIFICATION 6T198.
- ALL WIRING MUST BE CSA CERTIFIED AND UL RECOGNIZED COMPONENTS IN CATEGORY AVLV2,AWM RATED MINIMUM 80°C, MINIMUM FLAMMABILITY RATING OF VW-1.
- THE CONNECTORS USED MUST BE CSA CERTIFIED AND UL RECOGNIZED COMPONENTS IN CATEGORY RTRT2, ECBT2, OR DUXR2. COMPONENTS MUST MEET A MINIMUM FLAMMABILITY RATING OF 94V-0, OR
- THE CONNECTORS USED MUST BE CSA CERTIFIED AND UL RECOGNIZED COMPONENTS IN CATEGORY RTRT2, ECBT2, OR DUXR2. COMPONENTS MUST MEET A MINIMUM FLAMMABILITY RATING OF 94V-1.
- ALL OTHER PLASTICS USED MUST MEET A MINIMUM FLAMMABILITY RATING OF 94V-1.
- THE VENDOR SHALL BE A UL RECOGNIZED AND CSA CERTIFIED SUPPLIER OF WIRING HARNESSES. THE VENDORS UL RECOGNITION MARK AND CSA CERTIFICATION MARK SHALL BE APPLIED TO THE SMALLEST BUNDLE OR UNIT CONTAINER IN WHICH THE PRODUCT IS PACKAGED.
- DRAWING IS FOR INSPECTION PURPOSES ONLY. ACTUAL PART SHALL CONFORM TO ELECTRONIC DATABASE. ALL SHOWN DIMENSIONS SHALL CONFORM TO TABLE 1. DIMENSIONS NOT SHOWN SHALL CONFORM TO THE 2 PLACE DECIMAL TOLERANCES IN TABLE 1. THIS TABLE SUPERSEDES THE TITLE BLOCK.

DIMENSION RANGE	TOLERANCE	
	DECIMAL X.X	DECIMAL X.XX
0 to 1270.00	+/- 6.4	+/- 3.18
1270.1 to 2540.00	+/- 12.7	+/- 6.35
2540.1 to 6350.00	+/- 25.4	+/- 12.70

CRITICAL TO FUNCTION DIMENSIONS: THESE DIMENSIONS SHALL BE USED FOR DETERMINATION AND REQUALIFICATION OF PROCESS CAPABILITY (Cp, Cpk) PER THE DELL P/PPAP PROCESS.
 (THERE ARE 3 TOLERANCE TABLES TO SELECT FROM. SEE ENG0000137.)

- CABLE SHALL BE TESTED FOR INTERMITTENT FAILURES: WIRE CONTINUITY, CONTACT TO CONTACT MATING AND CONTACT TO WIRE BOND. ANY INTERMITTENT DETECTION SHALL BE DEEMED A FAILURE
- ATTACH PPID LABEL APPROXIMATELY WHERE SHOWN AND ALWAYS IN THE SAME ORIENTATION. LABEL SHALL CONFORM TO DELL SPEC 13190
- CABLES SHALL BE MARKED WITH DATE CODE, MANUFACTURER ID, APPROXIMATELY WHERE SHOWN USING (3,0,0,12) MIN. HEIGHT CHARACTERS. DATE CODE CONSISTS OF DAY (NUMERIC), MONTH (FIRST THREE LETTERS) AND YEAR (LAST TWO DIGITS). MARK SHALL INCLUDE DELL PART NUMBER (P/N: XXXXX).
- BULK ITEM CONTAINER SHALL HAVE A PPID LABEL AND A DELL P/N LABEL. PPID LABEL SHALL CONFORM TO DELL SPEC 13190. MORE THAN ONE ITEM MAY BE SHIPPED PER CONTAINER.
- ASSEMBLY SHALL BE CLEAN AND FREE FROM FOREIGN MATERIAL. DIRT, OIL, GREASE, OR OTHER CONTAMINANTS ARE NOT ALLOWED.
- CABLES SHALL MEET REQUIREMENTS LISTED IN DELL P/N ENG0000117 AND MECHANICAL REQUIREMENTS LISTED IN DELL P/N ENG0000120.
- ASSEMBLY SHALL BE PACKAGED IN ACCORDANCE WITH DELL PACKAGING STANDARD 11500.
- PARTS SHALL BE PACKAGED FOR SUPPLIER INTERNAL DISTRIBUTION.
- APPLY HEAT SHRINK TUBE FOR SPECIFIED LENGTH. COLOR SHALL BE XXXX, AND MUST MEET UL REQUIREMENTS PER NOTE 5.
- APPLY HEAT SHRINK TUBE WITHOUT HEATING TO SPECIFIED LENGTH. COLOR SHALL BE BLACK AND MUST MEET UL REQUIREMENTS PER NOTE 5.
- CABLE CONDUCTOR 1 TO BE CONNECTED TO CONNECTOR PIN 1 ON BOTH SIDES.
- CABLE MUST COMPLY WITH PINOUT TABLE AS SHOWN.
- CABLE SHALL BE MARKED IN PERMANENT AND LEGIBLE MANNER WITH MINIMUM TEXT HEIGHT OF .120 (3.0mm) WITH THE FOLLOWING XXX INFORMATION APPROXIMATELY WHERE SHOWN.
- CABLE SHALL BE MARKED IN PERMANENT AND LEGIBLE MANNER WITH ICONS APPROXIMATELY WHERE SHOWN.
- ALL WIRES SHALL BE (XX) AWG WITH MINIMUM STRANDING OF XX/.XXX. (# OF STRANDS/DIAMETER) WIRE MUST MEET REQUIREMENTS IN NOTE 4.

B-C : 30mm
 C-D : 179mm
 C-E : 110mm
 C-T : 300mm
 T-D : 121mm
 D-E : 69mm

A-I : 40mm
 I-K : 45mm
 I-J : 55mm
 K-J : 10mm

A-B : 410mm
 A-Q : 72mm
 A-R : 243mm
 A-S : 307mm

B-G : 68mm
 B-H : 109mm
 B-U : 109mm

A-L : 40mm
 A-M : 125mm
 A-O : 125mm
 A-V : 125mm

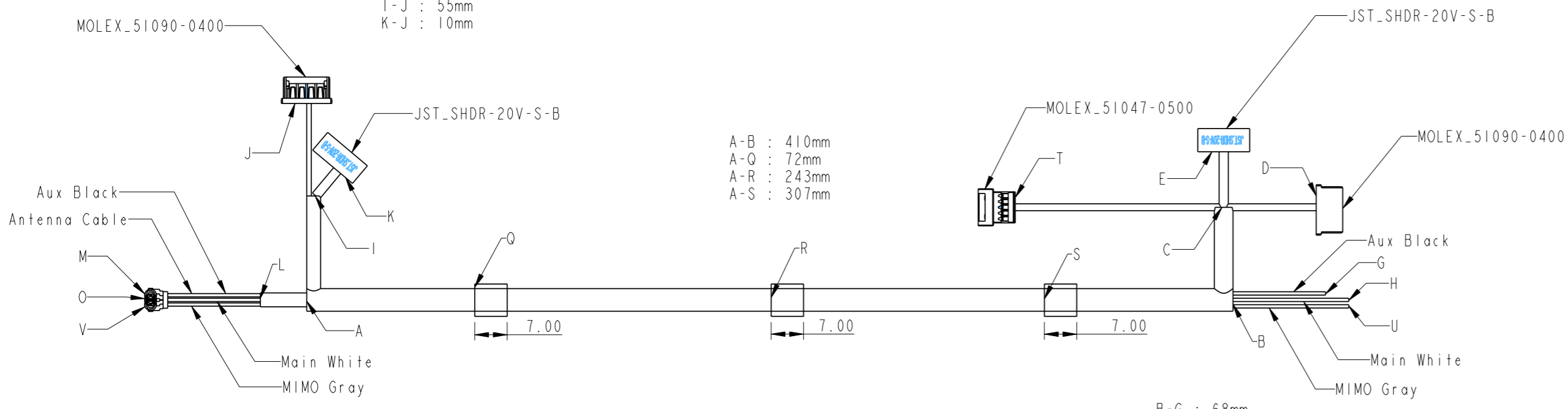

PROPRIETARY NOTE: THIS SHEET OF ENGINEERING DRAWINGS AND SPECIFICATIONS CONTAINS CONFIDENTIAL, TRADE SECRET, AND OTHER PROPRIETARY INFORMATION OF DELL INC. ("DELL"). THIS DOCUMENT MAY NOT BE TRANSFERRED OR COPIED WITHOUT THE EXPRESS WRITTEN AUTHORIZATION OF DELL. IN ADDITION, NEITHER THIS SHEET NOR THE INFORMATION IT CONTAINS MAY BE USED BY OR DISCLOSED TO ANY THIRD PARTY WITHOUT DELL'S EXPRESS WRITTEN CONSENT.

DATE	TOOLING NO.	REMARK

EAX20		DC020003U0L			REMARK	
RANGE	TOLERANCE	SCALE	UNIT	SIGNATURE	NAME	DATE
201 ABOVE	± 0.3	TOL. 1 PLC	2 PLC	DRN BY.	A25	Oct 05
101 - 200	± 0.25	+		CHK BY.		
51 - 100	± 0.2			PRJ ENGR		
31 - 50	± 0.15			ENGR APPRO		
30 mm BELOW	0.1			SIZE	SHEET 1 OF 1	DRAWING NO.

Compal Electronics, Inc.		
EAX20_HINGE_CABLE_L_ANTIENNA		
REV 0	VERSION 8	

3. Gain Patterns

- Main Antenna

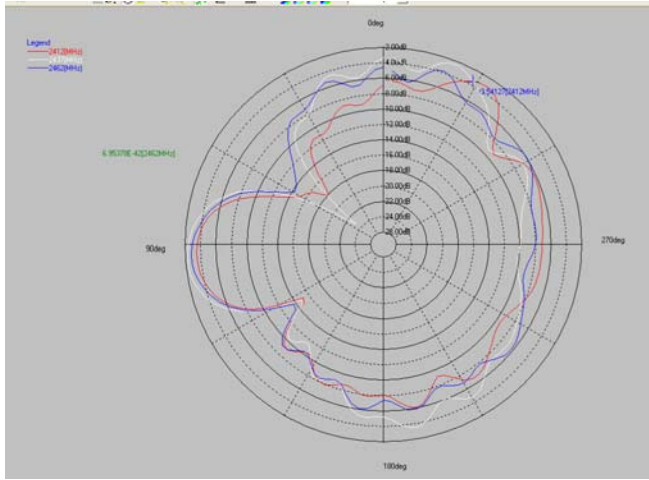

Vertical

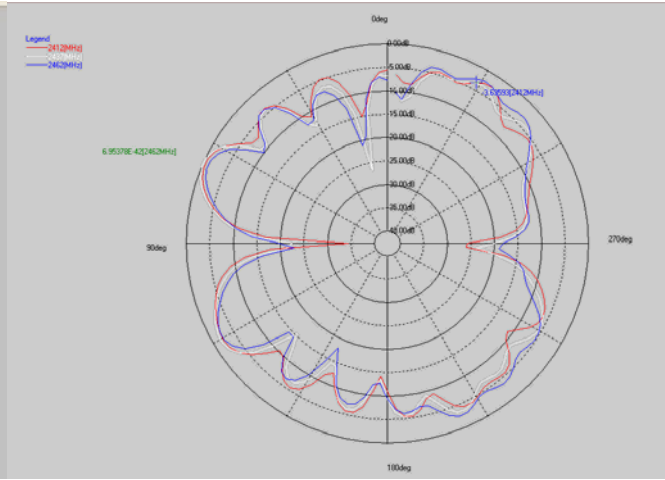

Horizontal

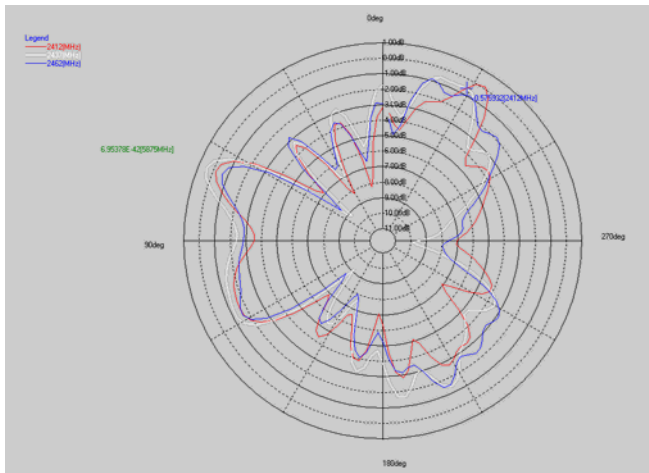

Hori + Vert

Frequency	2412MHz	2437MHz	2462MHz
Horizontal peak gain(dBi)	-0.52	-0.03	-1.18
Vertical peak gain(dBi)	-3.20	-2.26	-2.78
Hori + Vert peak gain(dBi)	0.09	0.45	-0.61
Hori + Vert avg gain	-3.95	-3.63	-3.78

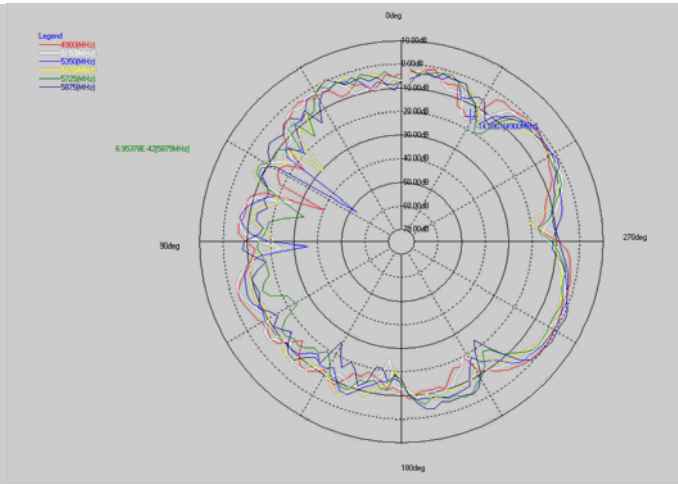
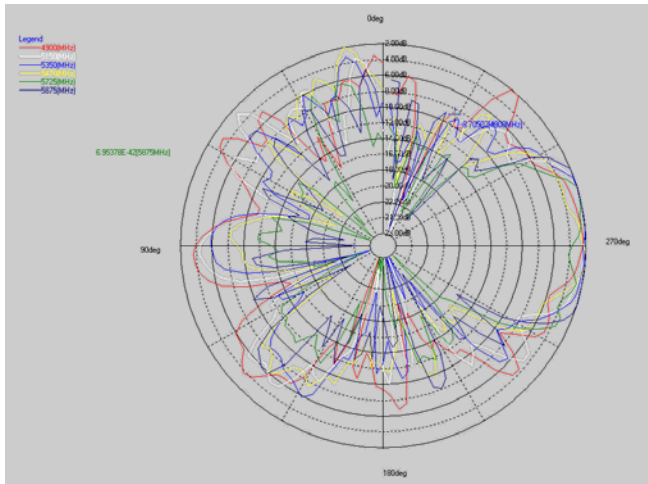

Vertical

Horizontal

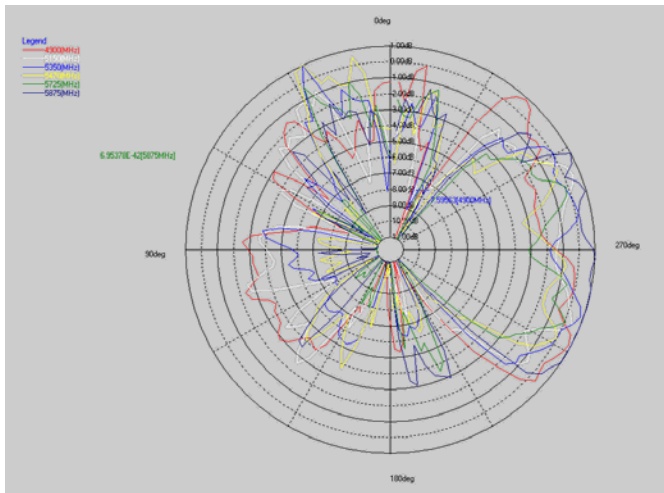

Hori + Vert

Frequency	4900MHz	5150MHz	5350MHz	5470MHz	5725MHz	5875MHz
Horizontal peak gain(dBi)	-0.27	-0.89	0.44	0.21	-1.03	1.38
Vertical peak gain(dBi)	-2.07	-1.34	-0.97	-1.56	-1.66	0.41
Hori + Vert peak gain(dBi)	0.86	0.55	1.06	1.03	0.03	2.36
Hori + Vert avg gain	-3.51	-4.22	-4.3	-4.85	-4.97	-4.37

- Mimo Antenna

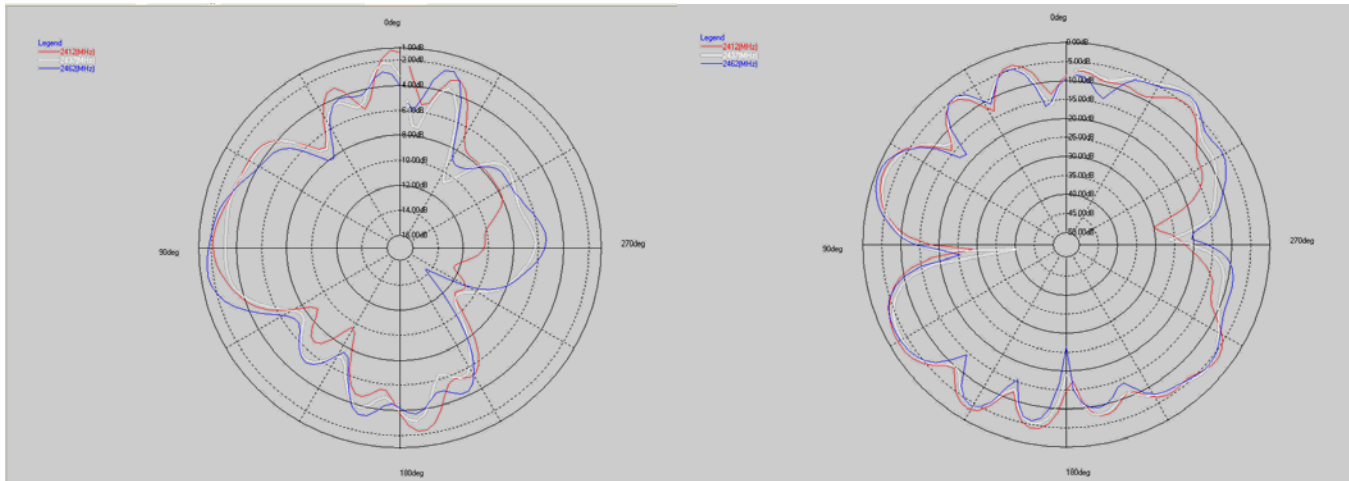

Vertical

Horizontal

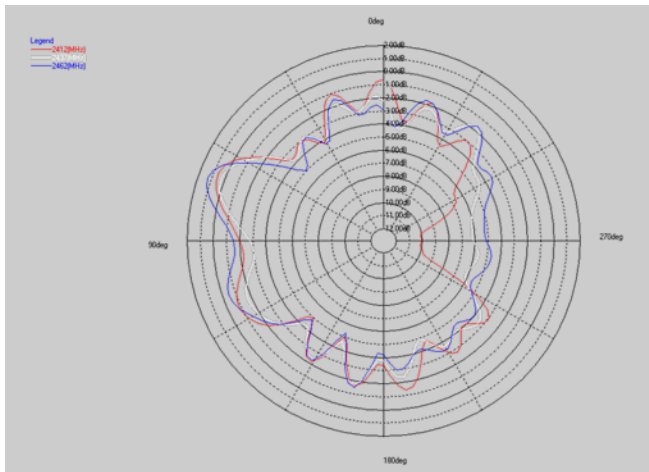

Hori + Vert

Frequency	2412MHz	2437MHz	2462MHz
Horizontal peak gain(dBi)	-1.76	-2.46	-0.72
Vertical peak gain(dBi)	-1.23	-2.23	-1.57
Hori + Vert peak gain(dBi)	0.62	0.28	1.27
Hori + Vert avg gain	-3.36	-3.25	-2.96

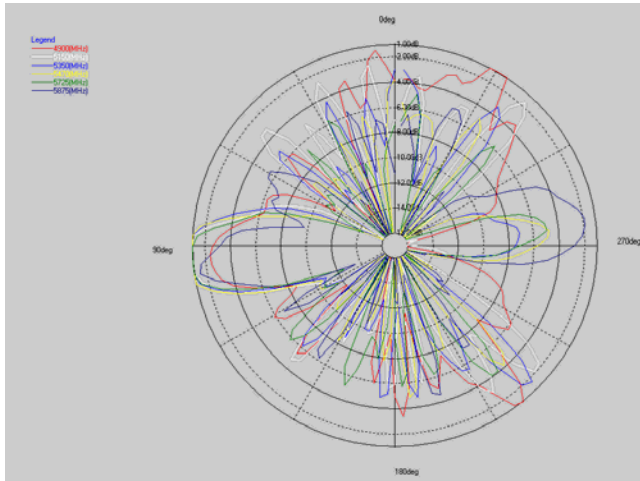

Vertical

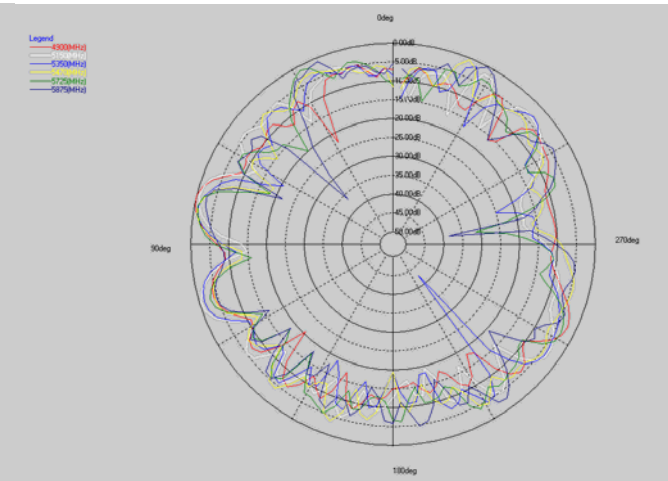

Horizontal

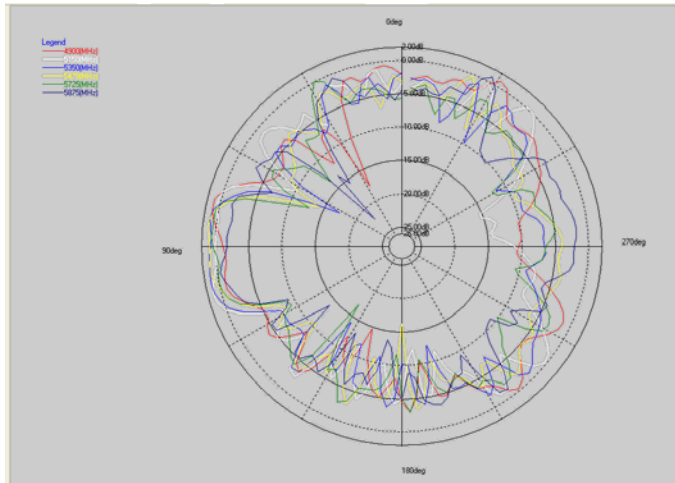

Hori + Vert

Frequency	4900MHz	5150MHz	5350MHz	5470MHz	5725MHz	5875MHz
Horizontal peak gain(dBi)	-0.04	-0.53	-0.98	-0.65	-0.93	-0.24
Vertical peak gain(dBi)	0.27	-0.26	0.59	0.69	-0.54	-1.48
Hori + Vert peak gain(dBi)	0.96	1.09	1.09	1.15	0.60	0.81
Hori + Vert avg gain	-4.13	-4.35	-4.63	-4.67	-4.89	-4.8

- Aux Antenna

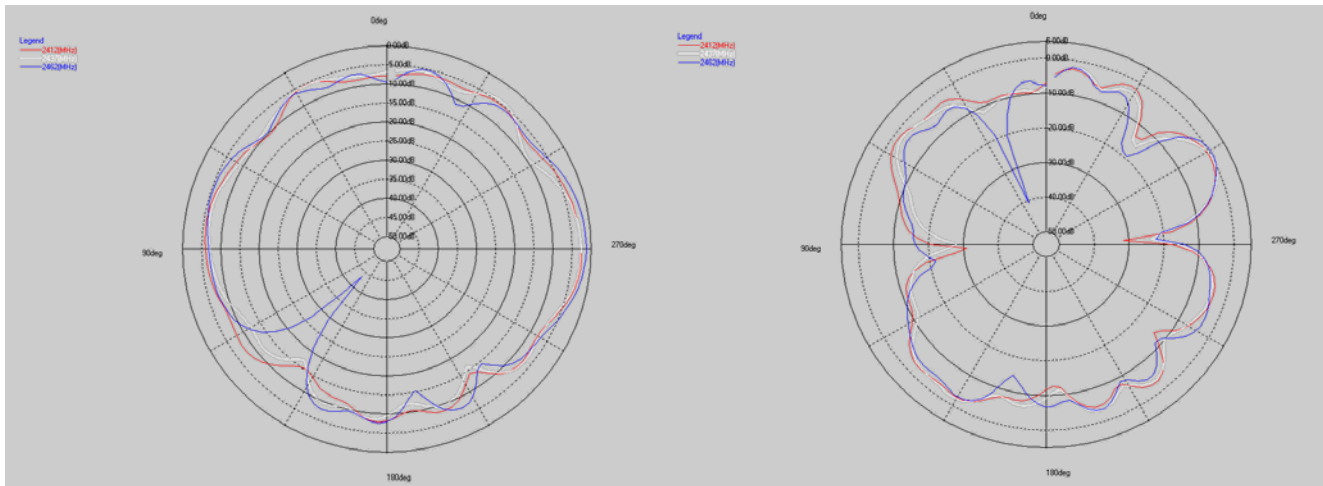

Vertical

Horizontal

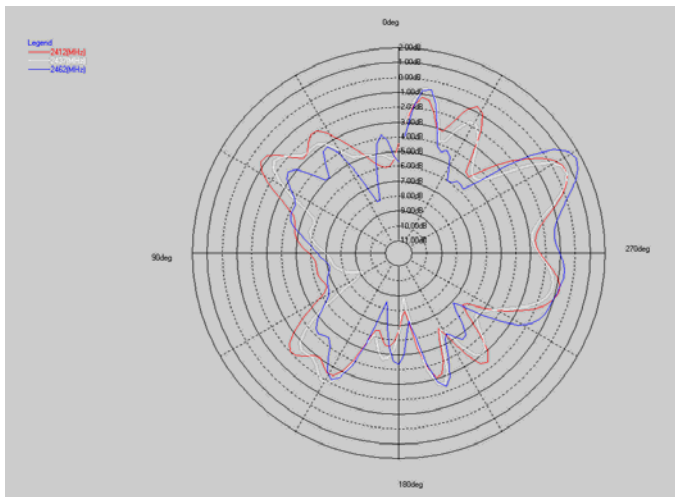

Hori + Vert

Frequency	2412MHz	2437MHz	2462MHz
Horizontal peak gain(dBi)	-0.48	-0.04	0.54
Vertical peak gain(dBi)	-2.47	-2.63	-1.26
Hori + Vert peak gain(dBi)	0.65	0.65	1.66
Hori + Vert avg gain	-3.35	-3.74	-3.77

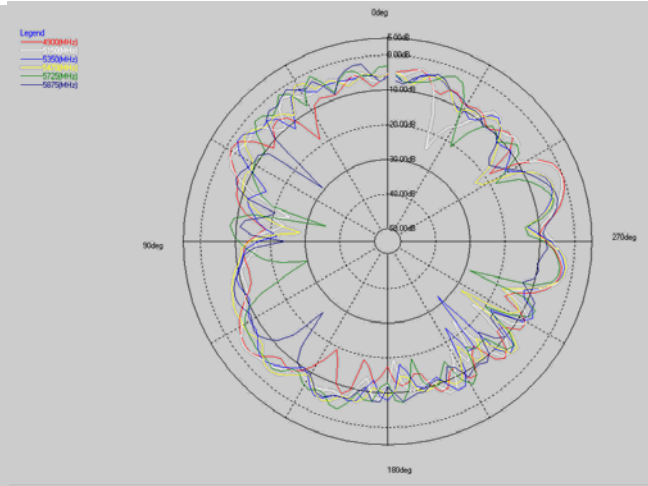
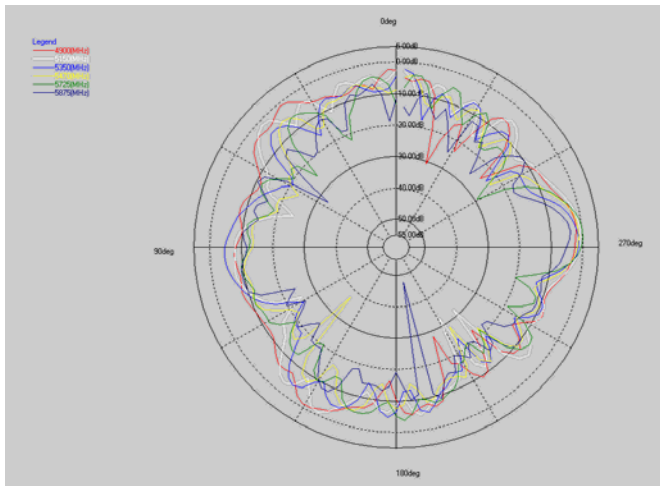

Vertical

Horizontal

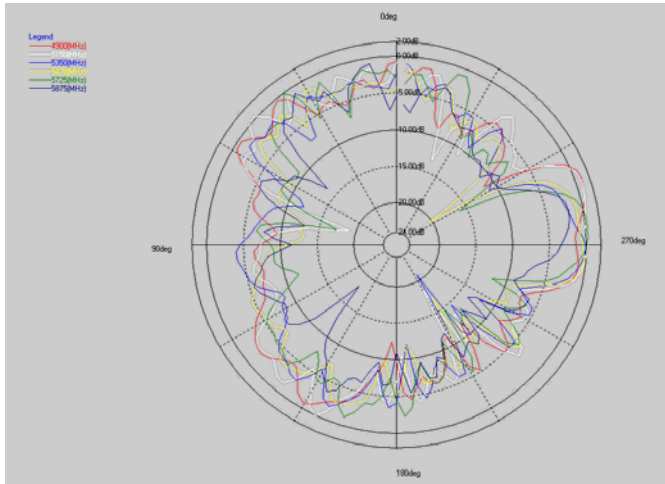

Hori + Vert

Frequency	4900MHz	5150MHz	5350MHz	5470MHz	5725MHz	5875MHz
Horizontal peak gain(dBi)	-0.02	-0.47	-1.82	-1.62	-1.31	-1.24
Vertical peak gain(dBi)	-1.11	-0.51	-1.09	-1.13	0.06	-3.62
Hori + Vert peak gain(dBi)	0.95	0.90	0.10	0.15	0.25	-0.26
Hori + Vert avg gain	-4.26	-4.14	-4.62	-4.49	-4.76	-4.79