

# Certification of Compliance

## CFR 47 Part 15 Subpart C

Test Report File No. : 11-IST-0481                      Date of Issue : April 07, 2011

Model(s) : EB07  
Kind of Product : E-BOOK  
FCC ID : QDMEB07  
Applicant : IRIVER LIMITED  
Address : iriverhouse, 902-5, Bangbae-dong, Seocho-gu, Seoul, Korea  
Manufacturer : IRIVER LIMITED  
Address : iriverhouse, 902-5, Bangbae-dong, Seocho-gu, Seoul, Korea  
Factory : IRIVER CHINA CO.,LTD.  
Address : SSL. Sci&Tech. North Industry Park, Dongguan, Guangdong, 523-808 China

### Test Result

Positive

Negative

Reviewed By

Approved By



S.J.CHO / EMC Group Manager



B.S.KIM / Chief

### Comment (s)

- Investigations requested : Measurement to the relevant clauses of FCC rules and regulations Part 15 Subpart C.
- The test report is consists of 35 pages.
- The test result only responds to the tested sample.
- It is not allowed to copy this report even partly without the allowance of IST Co.,Ltd..
- This equipment as for has been shown to be capable of continued compliance with the applicable technical standards as indicated in the measurement report and was tested in accordance with the measurement procedures specified in ANSI C63.4

I assume full responsibility for accuracy and completeness of these data.

## TABLE OF CONTENTS

Table of contents	2
Information of test laboratory, Environmental conditions, Power used	3
Product information	4
Measurement Uncertainty Calculations	5
Equipment Under Test	6
Summary	7
- Conducted Emission	8
- Radiated Emission	13
- Peak power output	22
- Band edge	25
- 6dB Band	31
- Power Density	34
- Antenna Requirements	37

Note:

## INFORMATIONS OF TEST LABORATORY

IST Co., Ltd.

400-19, Singal-dong, Giheung-gu, Yongin-si, Kyonggi-Do, 449-860, Korea

TEL : +82 31 326 6700

FAX : +82 31 326 6797



- VCCI Registration No. : 1739
- FCC Registration No. : 400603
- KCC Registration No. : KR0018
- FCC MRA Registration No. : 801060
- KOLAS Registration No. : KT118

## ENVIRONMENTAL CONDITIONS

Temperature 21.5 °C Humidity 45 %  
Atmospheric pressure 1004 mbar

## POWER SUPPLY SYSTEM USED

Power supply system DC 3.7V (Refer to the product information)

## PRODUCT INFORMATION

CPU	Freescale iMX-508(Cortex-A8/800MHz)
Display Type	EPD(LG Display-6.0" / LB060X01)
Display Resolution	XGA(1024 x 768)
Color Depth	16 Gray Level (Monochrome)
Key Structure	Power Slide / Home, Back, Enter, Option key(4 Key) / Navi Key(4 Key) / QWERTY Keyboard (38 Key)
Capacity	2GB Only
Storage Type	Movi NAND 2GB
External Storage	SD(SDHC/32G)
Memory	1Gbit(Mobile DDR SDRAM : 200MHz)
Connection Type	Mini USB 2.0
Power Charge	USB Charging (DC 5V)
Battery	Li-Polymer 3.7 V / 1800mA/h
Network	802.11 b/g Support

- Regards to the frequency band operation; the highest that was included the lowest, middle and highest frequency of channel were selected to perform the test, and then shown on this report.

- Please refer to user's manual.

## Measurement Uncertainty Calculations

The measurement uncertainties stated were calculated in accordance with the requirements of NIST Technical Note 1297 and NIS 81 (1994).

TYPE	Contribution	Probability Distribution	Uncertainty	Remark	
B	<b>AMN</b>				
	Impedance	Triangular	+2.6/-2.7 dB	CISPR	
	Voltage Division Factor	normal (k=2)	±0.2		
	Attenuation : AMN to Receiver	normal (k=2)	±0.1		
		<b>Receiver (ESCI (S/N:100374))</b>			
	Sine-Wave Voltage Accuracy	normal (k=2)	±1.0 dB	CISPR	
	Pulse Amplitude Response	Rectangular	±1.5 dB		
Pulse Repetition Rate Response	Rectangular	±1.5 dB			
	Mismatch AMN to Receiver	U-Shaped	+0.7/-0.8 dB	CISPR	
	Reading	normal (k=1)	±0.1		
Combined Standard Uncertainty		normal	<b>± 1.8 dB</b>		
Expanded Uncertainty U		normal (k=2)	<b>± 3.6 dB</b>	<b>95 %</b>	

***U = -3.70 / +3.42 (k=2, 95.45% confidence level)***

TYPE	Contribution	Probability Distribution	Uncertainty	Remark	
B	<b>Antenna</b>				
	AF factor	Normal (k=2)	±0.56	CAL.	
	AF frequency interpolation	Rectangular	±0.30 dB	CISPR	
	AF height deviations	Rectangular	±0.50 dB	CISPR	
	directivity difference	Rectangular	±0.30 dB	CISPR	
	phase center location(3 m)	Rectangular	+1.0/-0.0 dB	CISPR	
	phase center location(10 m)	Rectangular	±1.0 dB	CISPR	
		<b>Receiver</b>			
	Sine Wave Voltage Accuracy	Normal (k=2)	±0.20 dB	CAL.	
	Pulse Amplitude Sensibility	Normal (k=2)	±0.40 dB	CAL.	
	Pulse Frequency Response	Normal (k=2)	±0.57 dB	CAL.	
	Random Noise	Normal (k=2)	±0.35 dB	CAL.	
	Mismatch : Antenna - receiver	U-Shaped	+0.9/-1.0 dB	CISPR	
	Table height	Normal (k=2)	±0.01 dB	CISPR	
	Separation distance(3 m)	Rectangular	±0.30 dB	CISPR	
Separation distance(10 m)	±0.10 dB				
Combined standard Uncertainty		Normal	<b>± 1.13</b>		
Expanded Uncertainty U		Normal (k=2)	<b>± 2.26 dB</b>	<b>95 %</b>	

***U = ±2.26 (k=2, 95% confidence level)***

## Equipment Under Test

**EUT Type :**

- Table-Top.  Floor-Standing.
- Table-Top and Floor-Standing (Combination).
- Built-in

**Operation – mode of the E.U.T. :**

The equipment under test was operated during the measurement under following conditions :

- Standby Mode
- Operational Condition :  Continue Transmitting

## SUMMARY

### WLAN Mode ( 2412 MHz ~ 2462 MHz)

Applied Standard : FCC CRF Part 15 Subpart C : 2008

Standard Section	Description	result	remark
15.207	AC Conducted Emission	Pass	Meet the requirements
15.209	Field Strength of Harmonics	Pass	Meet the requirements
15.247(b)	Peak Power Output	Pass	Meet the requirements
15.247(d)	Band Edge	Pass	Meet the requirements
15.247(a)	6dB Bandwidth	Pass	Meet the requirements
15.247(d)	Power Density	Pass	Meet the requirements
15.203	Antenna requirement	-	Meet the requirements

### Test Date

Begin of Testing : March 21, 2011 - End of Testing : April 05, 2011

Prepared By



---

U.H. Ryu / Senior Engineer

## Conducted Emissions:

The measurement were performed over the frequency range of 0.15 MHz to 30 MHz using a 50 Ω/50 uH LISN as the input transducer to a Spectrum Analyzer or a Field Intensity Meter. The measurements were made with the detector set for "Peak" amplitude within a bandwidth of 10 kHz or for "quasi-peak" & "Average" within a bandwidth of 9 KHz.

### -Procedure of Test

The line-conducted facility is located inside a shielded room No.1. A 1 m X 1.5 m wooden table 80 cm height is placed 40 cm away from the vertical wall and 1.5 m away from the other wall of the shielded room. The R/S ESCI and Hyup-Rip KNW-407 LISN are bonded to bottom of the shielded room. The EUT is located on the wooden table with distance more than 80 cm from the LISN and powered from the EMCO LISN .The peripheral equipment is powered from the other LISN. Power to the LISNs are filtered by a noise cut power line filters. All electrical cables are shielded by braided tinned steel tubing with inner  $\phi$  1.2 cm. If the EUT is a DC-powered device, power will be derived from the source power supply it normally will be powered from and this supply lines will be connected to the EMCO LISN. All interconnecting cables more than 1m were shortened by non-inductive bundling to a 1m length. Sufficient time for the EUT, support equipment, and test equipment was allowed in order for them to warm up to their normal operating conditions. The RF output of the LISN was connected to the R/S receiver to determine the frequency producing the maximum emission from the EUT. The frequency producing the maximum level was reexamined using Quasi-Peak mode by manual measurement, after scanned by automatic Peak mode for frequency range from 0.15 to 30 MHz. The bandwidth of the receiver was set to 10 kHz. The EUT, peripheral equipment, and interconnecting cables were arranged and manipulated to maximize each EME emission.

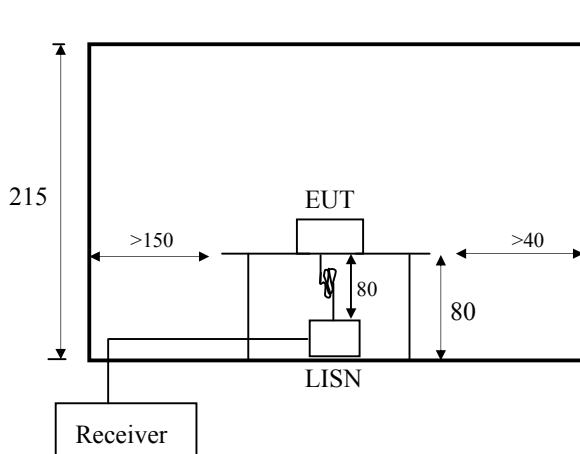

**< Side View >**

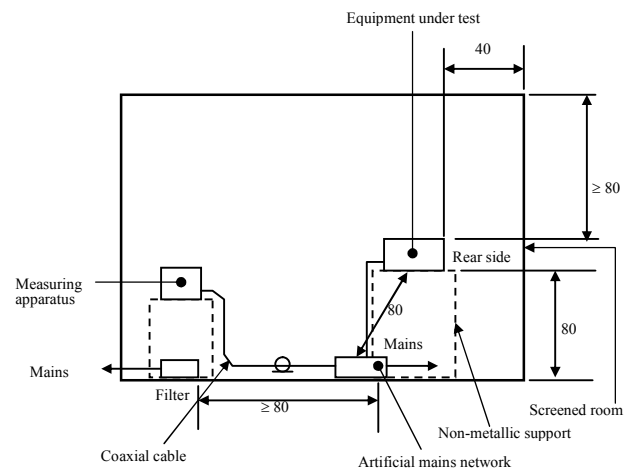

**< Concept Drawing >**



**Limits**

According to § 15.207(a) except as shown in paragraphs (b) and (c) of this section, for an intentional radiator that is designed to be connected to the public utility (AC) power line, the radio frequency voltage that is conducted back onto the AC power line on any frequency or frequencies within the band 150 kHz to 30 MHz shall not exceed the limits in the following table, as measured using a 50 μH/50 ohms line impedance stabilization network(LISN). Compliance with the provisions of this paragraph shall be based on the measurement of the radio frequency voltage between each power line and ground at the power terminal. The lower limit applies at the boundary between the frequency ranges.

Frequency Range (MHz)	Limits	
	Quasi-peak	Average
0.15 to 0.50	66 to 56*	56 to 46*
0.50 to 5	56	46
5 to 30	60	50

\* Decreases with the logarithm of the frequency.

Test specification.

According to FCC CFR Title 47 Part 15 Subpart C Section 15.207

### Conducted Emissions

[Applicable]

◆ Test Equipment Used

Model Name	Description	Manufacturer	Calibration Date	Serial No.
ESCI	Test Receiver	Rohde & Schwarz	Jul. 13, 2010	100373
KNW-407	LISN	Hyup-Rip	Oct. 13, 2010	8-833-10
ESH3-Z2	Pulse Limiter	Rohde & Schwarz	May 21, 2010	357.8810.52

◆ Test Accessories Used

Type	Manufacturer
Aneroid Barometer	Sato
Hygrometer	Sato

◆ Test Program                      USB Communication

◆ Test Date                              March 21, 2011

◆ Test Area                              Conducted Room No.1

Note :     *The used equipment is calibrated in regular for every year.*

### Conducted Emissions Result

Phase : Live

RBW 9 kHz  
MT 160 ms  
PREAMP OFF



Att 10 dB

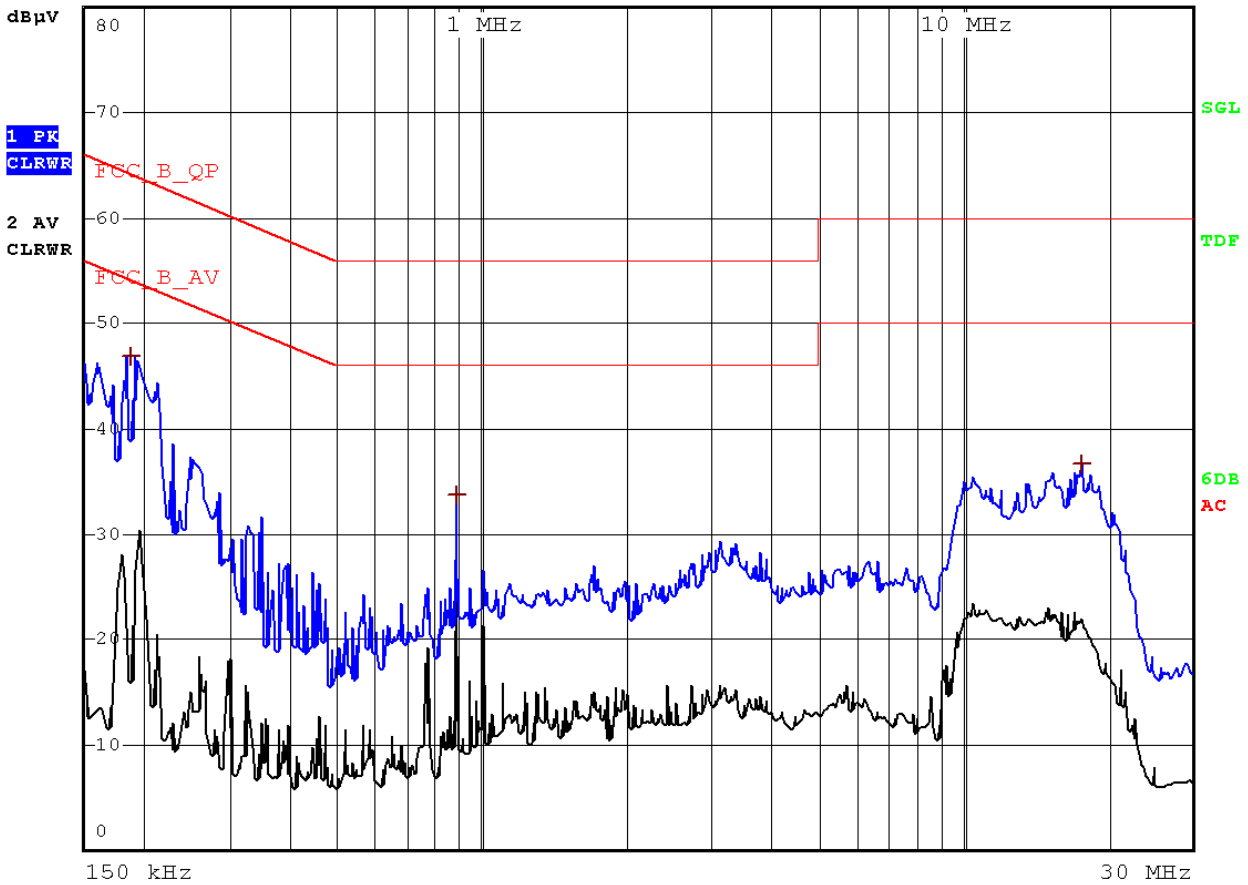

Model Name : EB07 120 Vac/ 60 Hz Phase : Live

Freq. [MHz]	Measurement [dB µV]		Limit [dB µV]		Insertion Loss [dB]	Cable Loss [dB µV]	Result [dB µV]		Margin [dB]	
	Q-peak	Average	Q-peak	Average			Q-peak	Average	Q-peak	Average
0.190	44.32	26.27	64.04	54.04	0.27	0.01	44.60	26.55	19.44	27.49
0.886	32.41	32.32	56.00	46.00	0.11	0.03	32.55	32.46	23.45	13.54
17.746	27.57	19.70	60.00	50.00	0.45	0.17	28.19	20.32	31.81	29.68

### Conducted Emissions Result

Phase : Neutral



RBW 9 kHz  
MT 160 ms  
PREAMP OFF

Att 10 dB

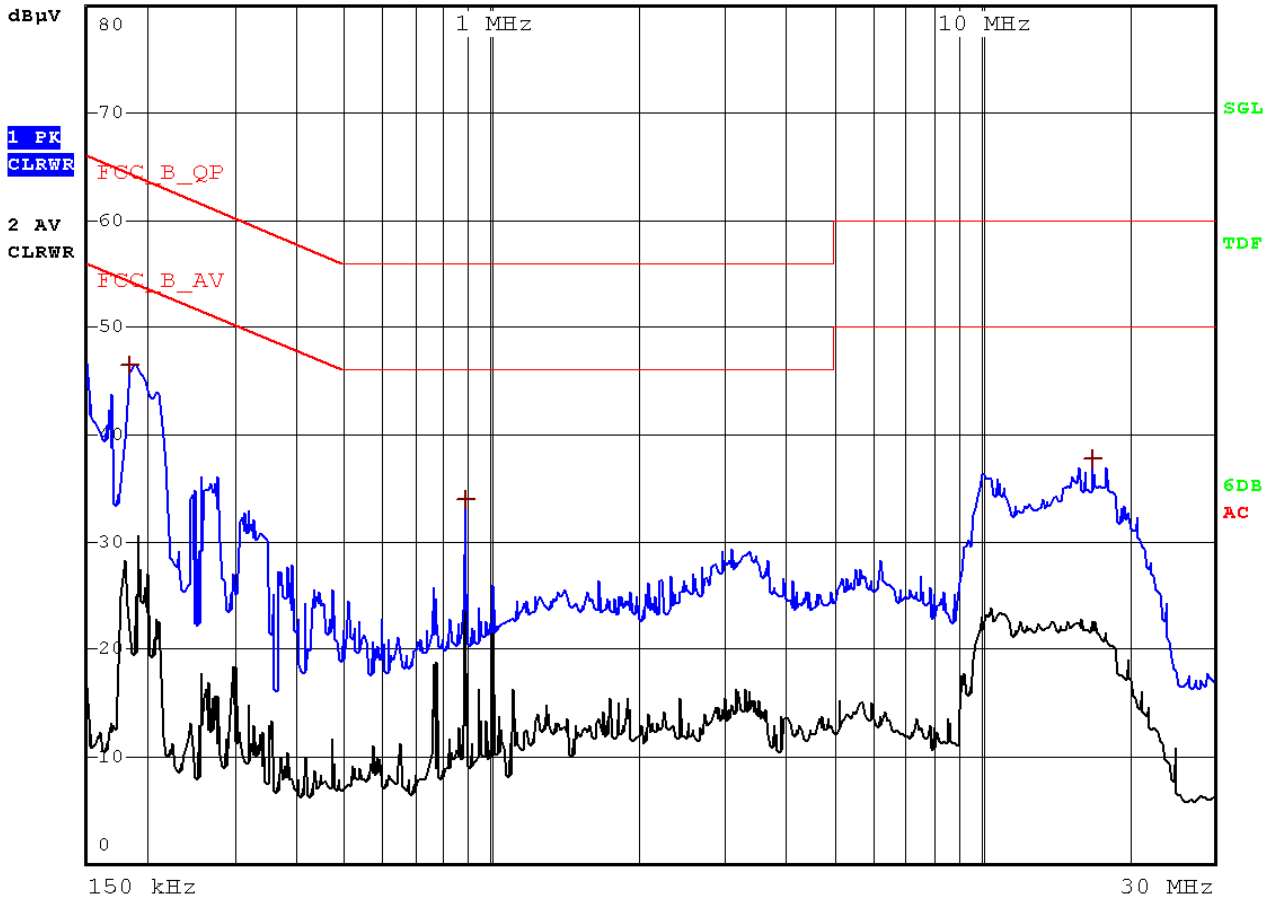

Model Name : EB07 120 Vac/ 60 Hz Phase : Neutral

Freq. [MHz]	Measurement [dB µV]		Limit [dB µV]		Insertion Loss [dB]	Cable Loss [dB µV]	Result [dB µV]		Margin [dB]	
	Q-peak	Average	Q-peak	Average			Q-peak	Average	Q-peak	Average
0.186	43.62	25.63	64.21	54.21	0.29	0.01	43.92	25.93	20.30	28.29
0.886	32.27	32.09	56.00	46.00	0.12	0.03	32.42	32.24	23.58	13.76
16.898	30.04	20.18	60.00	50.00	0.43	0.16	30.63	20.77	29.37	29.23

## Radiated Emissions:

The measurement was performed over the frequency range of 30MHz to 1GHz using antenna as the input transducer to a Spectrum analyzer or a Field Intensity Meter. The measurement was made with the detector set for "quasi-peak" within a bandwidth of 120kHz. Procedure of Test

Preliminary measurements were made at 3 meter using bi-log antennas, and spectrum analyzer to determine the frequency producing the max. emission in anechoic chamber. Appropriate precaution was taken to ensure that all emission from the EUT were maximized and investigated. The system configuration, mode of operation, turn-table azimuth and height with respect to the antenna were noted for each frequency found. The spectrum was scanned from 30MHz to 1000MHz using bi-log antenna. Above 1GHz, linearly polarized double ridge horn antennas were used. Final measurements were made at open site with 3-meters test distance using bi-log antenna or horn antenna. The OATS have been verified in regular for its normalized site attenuation. The test equipment was placed on a wooden table. Sufficient time for the EUT, peripheral equipment, and test equipment was allowed in order for them to warm up to their normal operating condition. Each frequency found during pre-scan measurements was re-examined by manual. The detector function was set to CISPR quasi-peak mode and the bandwidth of the receiver was set to 120kHz or 1MHz depending on the frequency of type of signal. The EUT, peripheral equipment and interconnecting cables were re-configured to the set-up producing the max. emission for the frequency and were placed on top of a 0.8-meter high nonmetallic 1 x 1.5 meter table. The EUT, peripheral equipment, and interconnecting cables were re-arranged and manipulated to maximize each emission. The turntable containing the system was rotated; the antenna height was varied 1 to 4 meters and stopped at the azimuth or height producing the maximum emission. Each emission was maximized by: varying the mode of operation to the EUT and/or peripheral equipment and changing the polarity of the antenna, whichever determined the worst-case emission. (The bandwidth below 1GHz setting on the field strength meter is 120KHz and above 1GHz is 1MHz.)

**Under 1GHz Test Setup:**

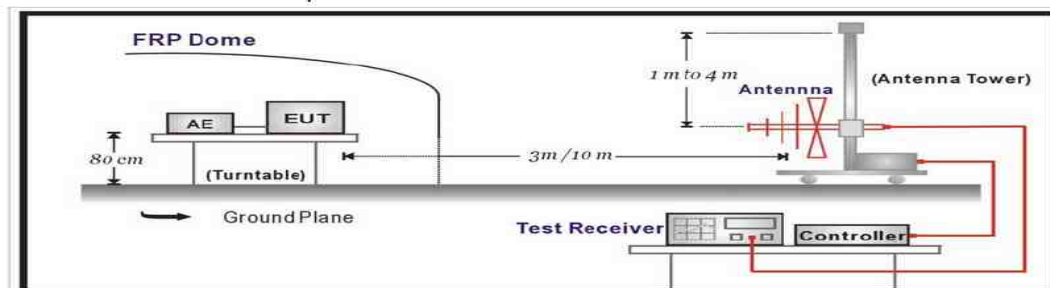

**Above 1GHz Test Setup:**

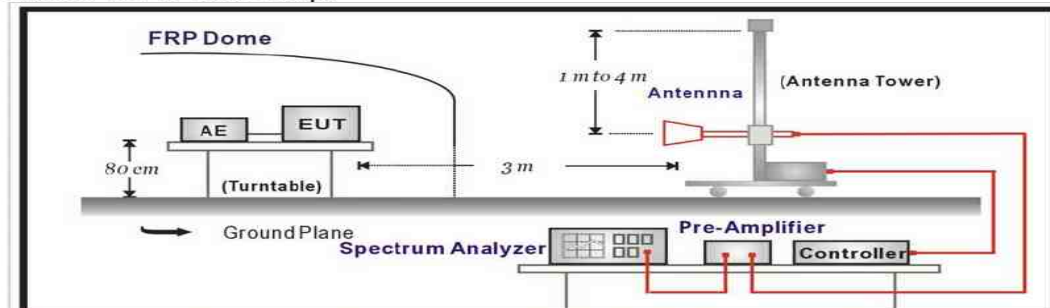

Below 30 MHz

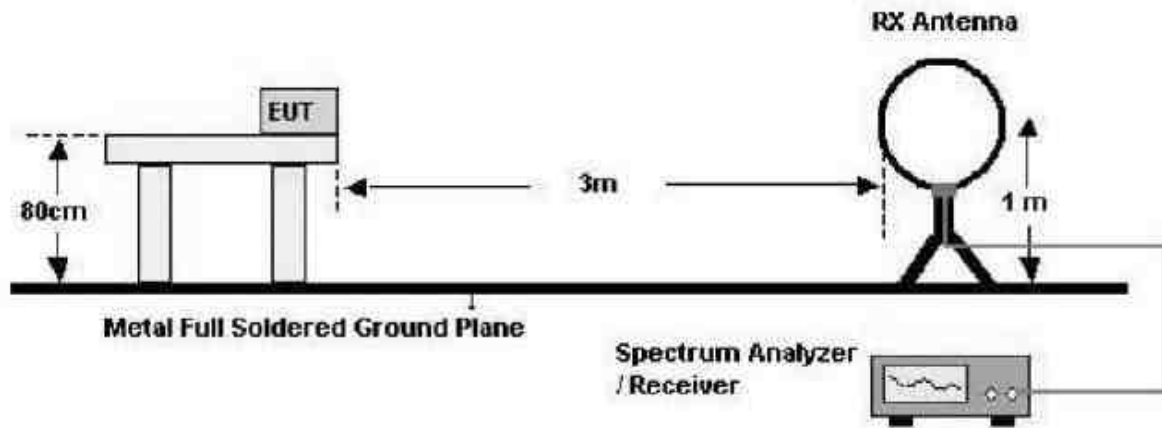

## Limits

Emissions radiated outside of the specified frequency bands, except for harmonics, Shall be attenuated by at least 20dB below the level of the fundamental or to the General radiated emission limits in paragraph 15.209, whichever is the lesser attenuation:

FCC Part 15 Subpart C Section 15.209 Limits		
Frequency (MHz)	$\mu\text{V}/\text{meter}$	$\text{dB}\mu\text{V}/\text{meter}(3 \text{ m})$
0.009-0.490	$2400/\text{F}(\text{KHz})$ at 300 m	$20\log 2400/\text{F}(\text{KHz})+80$
0.490-1.705	$24000/\text{F}(\text{KHz})$ at 30m	$20\log 24000/\text{F}(\text{KHz})+40$
1.705-30	30 at 30 m	49.5
30-88	100 at 3 m	40
88-216	150 at 3 m	43.5
216-960	200 at 3 m	46
Above 960	500 at 3 m	54

Remarks :

1.  $\text{RF Voltage}(\text{dBuV})=20\log \text{RF Voltage}(\mu\text{V})$
2.  $\text{dBuV}/\text{m} = \text{ERP}(\text{dBm})+106.92 \text{ dB} + 20\log(10\text{m}/3\text{m}) + 2.15\text{dB}(\text{conversion Factor for E.I.R.P})$
3. In the Above Table, the tighter limit applies at the band edges.
4. Distance refers to the distance in meters between the measuring instrument antenna and the closed point of any part of the device or system.

Test specification.

According to FCC CFR Title 47 Part 15 Subpart C Section 15.209

### Radiated Spurious Emission

[Applicable]

◆ Test Equipment Used

Name	Type	Manufacturer	Calibration. Date	Serial Number
ESCS30	EMI Receiver	Rohde & Schwarz	Oct. 13, 2010	828985/023
SPECTRUM ANALYZER	R3273	ADVANTEST	May 21, 2010	110600587
Loop Antenna	HFH2-Z2	Rohde & Schwarz	Oct. 23, 2010	8620771017
Log-bicon Antenna	VULB9161SE	Schwarz beck	Jul. 21, 2009	4089
HORN-Antenna	3115	EMCO	Dec. 22, 2009	9012-3602
HORN-Antenna	SAS-571	A.H. SYSTEMS	Dec. 22, 2009	500
PRE AMPLIFIER	8449B OPT H02	Rohde & Schwarz	Oct. 13, 2010	3008A0530

Note : 1. The calibration interval of the above test instruments is 12 months and the calibrations are traceable to RRL, KRISS, KTL and HCT.  
 2. The calibration interval of horn ant. and loop ant. is 24 months

#### Field Strength Calculation

The field strength is calculated by adding the Antenna Factor and Cable Factor, and subtracting the Amplifier Gain (if any) from the measured reading. For the limit is employed average value, therefore the peak value can be transferred to average value by subtracting the duty factor. The basic equation with a sample calculation is as follows:

$$\text{Peak} = \text{Reading} + \text{Corrected Factor}$$

Where, Corr. Factor = Antenna Factor + Cable Factor - Amplifier Gain (if any)

Test Plot : 9 KHz to 30 MHz

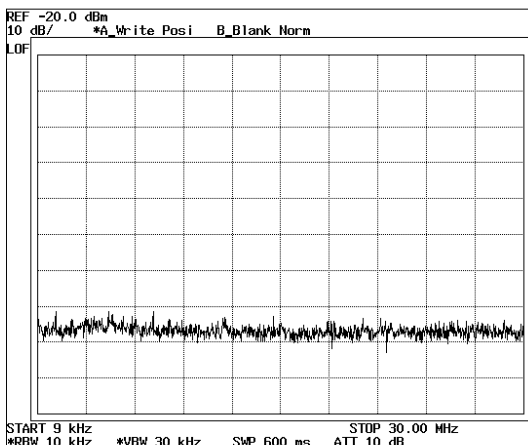

Note : The reading of emissions are attenuated more than 20 dB below the permissible limits and the field strength is too small to be measured.

### Radiated Emission Result

[Applicable]

EUT	EB07	PROBE	Below 1 GHz
POWER	3.7 V DC	NOTE	Continuous TX

Frequency MHz	Reading dBuV/m	P (H, V)	Ant. Factor dB	Cable Loss dB	AMP GAIN dB	Limit dBuV/m	Total dBuV/m	Margin dB
249.850	4.90	H	11.20	2.80	-	46.00	18.90	27.10
*320.960	6.40	V	12.40	3.10	-	46.00	21.90	24.10

Note :

1. The level of the radiated emission under 30 MHz is too small to be measured.
2. Remark "\*" means that the data is the worst emission level.
3. All reading levels are Quasi-peak value.
4. Measurement level = reading level + correct factor



EUT	EB07	PROBE	Above 1 GHz
POWER	3.7 V DC	NOTE	Low Ch

**Test Data\_802.11b**

Frequency MHz	Reading dBuV/m		P	Ant. Factor dB	Cable Loss dB	AMP GAIN dB	Limit dBuV/m		Total dBuV/m		Margin dB	
	Peak	AV					Peak	AV	Peak	AV	Peak	AV
	4870.26	52.70					38.50	V	10.80	11.20	36.17	74.0
7318.52	43.60	27.90	V	11.94	14.90	35.78	74.0	54.0	34.7	19.0	39.3	35.0
4870.26	51.20	39.40	H	10.80	11.20	36.17	74.0	54.0	37.0	25.2	37.0	28.8
7318.52	43.70	27.20	H	11.94	14.90	35.78	74.0	54.0	34.8	18.3	39.2	35.7

**Test Data\_802.11g**

Frequency MHz	Reading dBuV/m		P	Ant. Factor dB	Cable Loss dB	AMP GAIN dB	Limit dBuV/m		Total dBuV/m		Margin dB	
	Peak	AV					Peak	AV	Peak	AV	Peak	AV
	4870.26	47.90					32.60	V	10.80	11.20	36.17	74.0
7318.52	38.30	21.80	V	11.94	14.90	35.78	74.0	54.0	29.4	12.9	44.6	41.1
4870.26	48.20	33.70	H	10.80	11.20	36.17	74.0	54.0	34.0	19.5	40.0	34.5
7318.52	39.50	21.60	H	11.94	14.90	35.78	74.0	54.0	30.6	12.7	43.4	41.3

**Restricted Band Edge Test Data**

802.11b

Frequency MHz	Reading dBuV/m		P	Ant. Factor dB	Cable Loss dB	AMP GAIN dB	Limit dBuV/m		Total dBuV/m		Margin dB	
	Peak	AV					Peak	AV	Peak	AV	Peak	AV
	2397.15	41.90					29.80	V	9.25	7.80	36.18	74.0
2494.28	38.20	20.30	V	9.25	7.80	36.18	74.0	54.0	19.1	1.2	54.9	52.8
2397.15	40.10	30.10	H	9.25	7.80	36.18	74.0	54.0	21.0	11.0	53.0	43.0
2494.28	37.50	19.80	H	9.25	7.80	36.18	74.0	54.0	18.4	0.7	55.6	53.3

802.11g

Frequency MHz	Reading dBuV/m		P	Ant. Factor dB	Cable Loss dB	AMP GAIN dB	Limit dBuV/m		Total dBuV/m		Margin dB	
	Peak	AV					Peak	AV	Peak	AV	Peak	AV
	2371.59	39.40					29.10	V	9.25	7.80	36.18	74.0
2366.78	37.50	23.00	V	9.25	7.80	36.18	74.0	54.0	18.4	3.9	55.6	50.1
2371.59	38.60	28.10	H	9.25	7.80	36.18	74.0	54.0	19.5	9.0	54.5	45.0
2366.78	35.50	24.20	H	9.25	7.80	36.18	74.0	54.0	16.4	5.1	57.6	48.9

EUT	EB07	PROBE	Above 1 GHz
POWER	3.7 V DC	NOTE	Middle Ch

**Test Data\_802.11b**

Frequency MHz	Reading dBuV/m		P	Ant. Factor dB	Cable Loss dB	AMP GAIN dB	Limit dBuV/m		Total dBuV/m		Margin dB	
	Peak	AV					Peak	AV	Peak	AV	Peak	AV
	4868.52	48.20					37.50	V	10.80	11.20	36.17	74.0
7328.65	42.50	30.30	V	11.94	14.90	35.78	74.0	54.0	33.6	21.4	40.4	32.6
4868.52	49.70	39.60	H	10.80	11.20	36.17	74.0	54.0	35.5	25.4	38.5	28.6
7328.65	40.60	29.40	H	11.94	14.90	35.78	74.0	54.0	31.7	20.5	42.3	33.5

**Test Data\_802.11g**

Frequency MHz	Reading dBuV/m		P	Ant. Factor dB	Cable Loss dB	AMP GAIN dB	Limit dBuV/m		Total dBuV/m		Margin dB	
	Peak	AV					Peak	AV	Peak	AV	Peak	AV
	4868.52	49.30					38.40	V	10.80	11.20	36.17	74.0
7328.65	43.50	29.60	V	11.94	14.90	35.78	74.0	54.0	34.6	20.7	39.4	33.3
4868.52	48.60	40.50	H	10.80	11.20	36.17	74.0	54.0	34.4	26.3	39.6	27.7
7328.65	42.40	22.60	H	11.94	14.90	35.78	74.0	54.0	33.5	13.7	40.5	40.3

EUT	EB07	PROBE	Above 1 GHz
POWER	3.7 V DC	NOTE	High Ch

**Test Data\_802.11b**

Frequency MHz	Reading dBuV/m		P	Ant. Factor dB	Cable Loss dB	AMP GAIN dB	Limit dBuV/m		Total dBuV/m		Margin dB	
	Peak	AV					Peak	AV	Peak	AV	Peak	AV
	4920.35	47.60					35.40	V	10.80	11.20	36.17	74.0
7378.62	42.50	30.80	V	11.94	14.90	35.78	74.0	54.0	33.6	21.9	40.4	32.1
4920.35	49.70	37.10	H	10.80	11.20	36.17	74.0	54.0	35.5	22.9	38.5	31.1
7378.62	44.60	27.40	H	11.94	14.90	35.78	74.0	54.0	35.7	18.5	38.3	35.5

**Test Data\_802.11g**

Frequency MHz	Reading dBuV/m		P	Ant. Factor dB	Cable Loss dB	AMP GAIN dB	Limit dBuV/m		Total dBuV/m		Margin dB	
	Peak	AV					Peak	AV	Peak	AV	Peak	AV
	4920.35	49.10					33.90	V	10.80	11.20	36.17	74.0
7378.62	38.60	28.40	V	11.94	14.90	35.78	74.0	54.0	29.7	19.5	44.3	34.5
4920.35	47.10	34.10	H	10.80	11.20	36.17	74.0	54.0	32.9	19.9	41.1	34.1
7378.62	39.50	29.40	H	11.94	14.90	35.78	74.0	54.0	30.6	20.5	43.4	33.5

**Restricted Band Edge Test Data**

802.11b

Frequency MHz	Reading dBuV/m		P	Ant. Factor dB	Cable Loss dB	AMP GAIN dB	Limit dBuV/m		Total dBuV/m		Margin dB	
	Peak	AV					Peak	AV	Peak	AV	Peak	AV
	2484.93	44.60					32.00	V	9.25	7.8	36.18	74.0
2489.80	38.20	27.50	V	9.25	7.8	36.18	74.0	54.0	19.1	8.4	54.9	45.6
2484.93	42.40	31.20	H	9.25	7.8	36.18	74.0	54.0	23.3	12.1	50.7	41.9
2489.80	37.50	26.70	H	9.25	7.8	36.18	74.0	54.0	18.4	7.6	55.6	46.4

802.11g

Frequency MHz	Reading dBuV/m		P	Ant. Factor dB	Cable Loss dB	AMP GAIN dB	Limit dBuV/m		Total dBuV/m		Margin dB	
	Peak	AV					Peak	AV	Peak	AV	Peak	AV
	2500.34	42.90					29.10	V	9.25	7.90	36.18	74.0
2507.20	46.90	36.40	V	9.25	7.90	36.18	74.0	54.0	27.9	17.4	46.1	36.6
2371.59	43.70	28.10	H	9.25	7.90	36.18	74.0	54.0	24.7	9.1	49.3	44.9
2366.78	45.70	37.10	H	9.25	7.90	36.18	74.0	54.0	26.7	18.1	47.3	35.9

## Peak Power Output

### ◆ Test Equipment

The following test equipment are used during the test:

Item	Equipment	Manufacturer	Model no/Serial No.	Last Cal.
1	Spectrum Analyzer	ADVANTEST	R3273 / 95090431	Oct. 26, 2010
2	RF ROOM			

*Note : All equipment upon which need to calibrated are with calibration period of 1 year.*

### ◆ Limits

The maximum peak output power of the intentional radiator shall not exceed the following :

1. According to § 15.247(b)(3), for systems using digital modulation in the bands of 902-928 MHz, 2400-2483.5 MHz, and 5725-5850 MHz : 1Watt.
2. According to § 15.247(b)(4), the conducted output power limit specified in paragraph(b) of this section is based on the use of antennas with directional gains that do not exceed 6 dBi. Except as shown in paragraph(c) of this section, is transmitting antennas of directional gain greater than 6 dBi are used, the conducted output power from the intentional radiator shall be reduced below the stated values in paragraphs(b)(1), (b)(2), and (b)(3) of this section, as appropriate, by the amount in dB that the directional gain of the antenna exceeds 6 dBi

### ◆ Test Setup

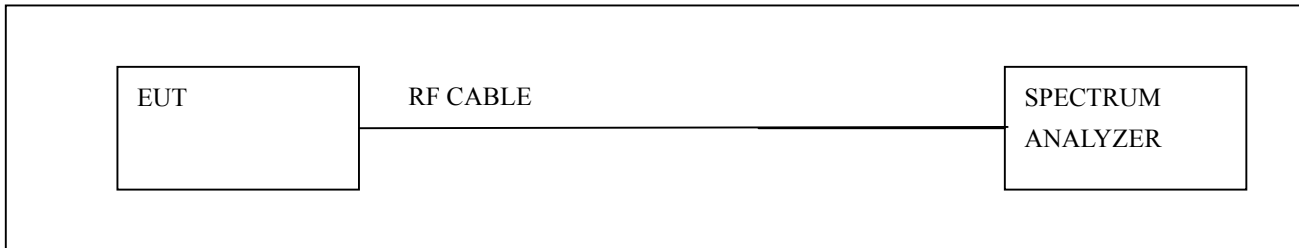

### ◆ Test Procedure

The transmitter output is connected to the Spectrum analyzer. The Spectrum analyzer is set to the peak power detection.

### Peak Power Test result

Product	EB07
Test Item	Peak Power Output
Test Mode	802.11b Mode / Tx Channel 1, 6, 11
Test Site	RF Room
Measurement Method	Conducted

Channel No.	Frequency (MHz)	Measure Level (dBm)	Limit (dBm)	Result
1	2412	7.96	1 Watt=30dBm	Pass
6	2437	8.12	1 Watt=30dBm	Pass
11	2462	7.91	1 Watt=30dBm	Pass

Channel 1

Channel 6

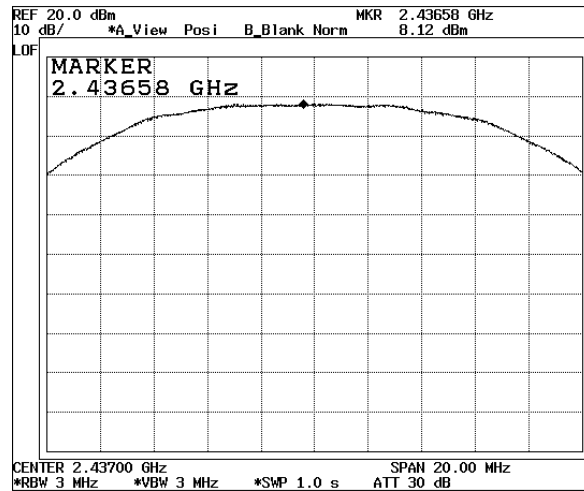
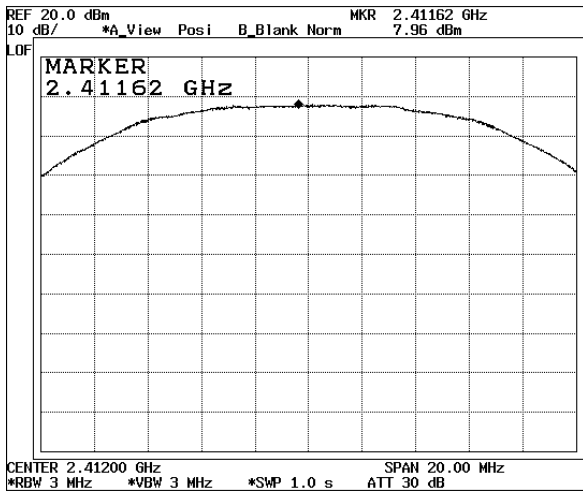

Channel 11

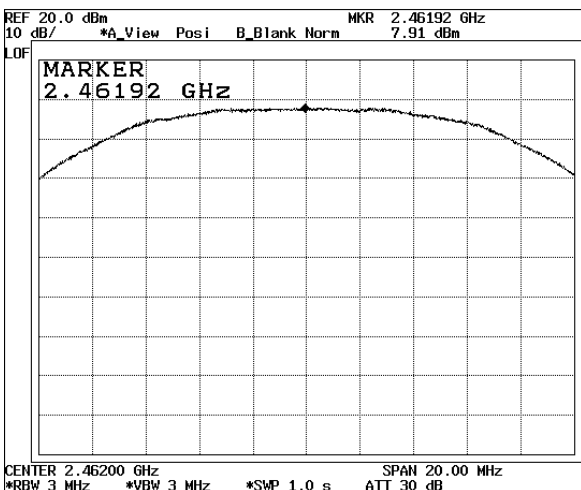

Note : Measurement level = reading level + correct factor

### Peak Power Test result

Product	EB07
Test Item	Peak Power Output
Test Mode	802.11g Mode / Tx Channel 1, 6, 11
Test Site	RF Room
Measurement Method	Conducted

Channel No.	Frequency (MHz)	Measure Level (dBm)	Limit (dBm)	Result
1	2412	10.38	1 Watt=30dBm	Pass
6	2437	10.21	1 Watt=30dBm	Pass
11	2462	9.95	1 Watt=30dBm	Pass

Channel 1

Channel 6

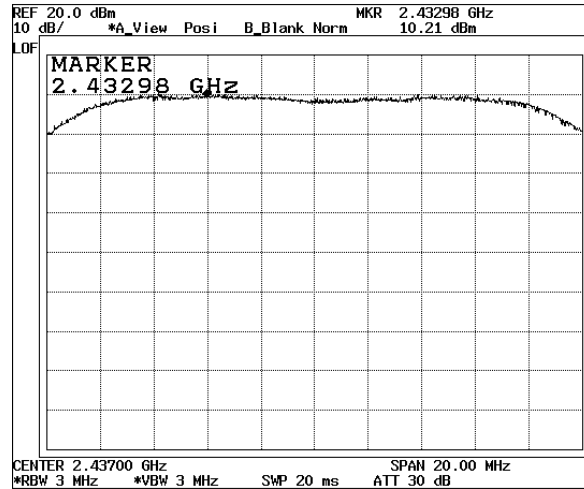
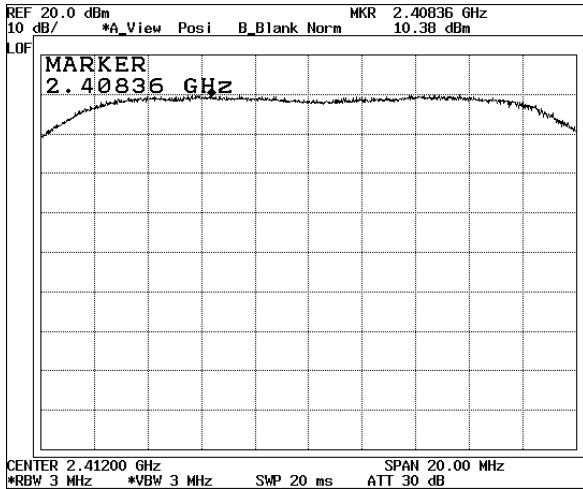

Channel 11

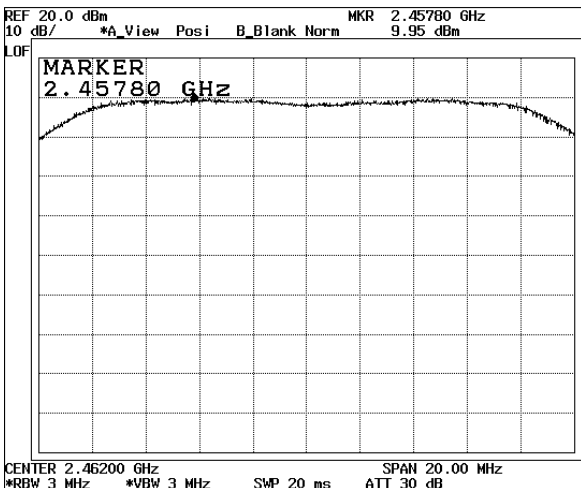

Note : Measurement level = reading level + correct factor

## Band Edge

### ◆ TEST Equipment

The following test equipment are used during the test:

Name	Type	Manufacturer	Calibration. Date	Serial Number
ESCS30	EMI Receiver	Rohde & Schwarz	Sep. 17, 2010	100171
SPECTRUM ANALYZER	R3273	ADVANTEST	Oct. 26, 2010	95095431
HORN-Antenna	3115	EMCO	Dec. 12, 2009	9012-3602
HORN-Antenna	HF906	Rohde & Schwarz	Dec. 12, 2009	100530
PRE AMPLIFIER	8449B OPT H02	Rohde & Schwarz	Oct. 13, 2010	3008A0530

*Note : 1. The calibration interval of the above test instruments is 12 months and the calibrations are traceable to RRL, KRISS, KTL and HCT.*

*2. The calibration interval of horn ant. and loop ant. is 24 months*

### ◆ Limits

In any 100 kHz bandwidth outside the frequency band in which the spread spectrum intentional radiator is operating, the radio Frequency power that is produced by the intentional radiator shall be at least 20 dB below that in the 100 kHz bandwidth within The band that contains the highest level of the desired power, based on either an RF conducted or a radiated measurement.

Attenuation below the general limits specified in section 15.209(a) is not required. In addition, radiated emission which fall in the restricted bands, as defined in section 15.205(a), must also comply with the radiated emission limits specified in section 15.209(a)(see Section 15.205(c)).

### ◆ Test setup

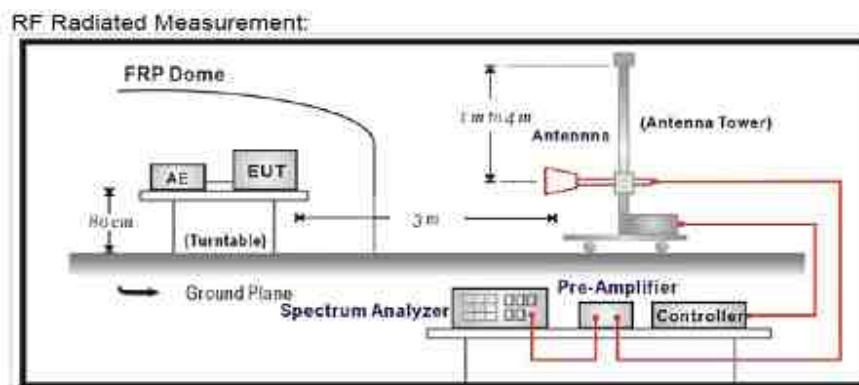

◆ Test procedure

The EUT and its simulators are placed on a turn table which is 0.8 meter above ground. The turn table can rotate 360 degrees to determine the position of the maximum emission level. The EUT was positioned such that the distance from antenna to the EUT was 3 meters. The antenna can move up and down between 1 meter and 4 meters to fine out the maximum emission level.

Both horizontal and vertical polarization of the antenna are set on measurement. In order to find the maximum emission, all of the interface cables must be manipulated according to ANSI C63.4:2003 on radiated measurement.

The bandwidth below 1 GHz setting on the field strength meter is 120 kHz, above 1GHz are 1MHz.

Test specification

According to FCC Part 15 Subpart C paragraph 15.247



Band Edge Test result

Product	EB07
Test Item	Band Edge
Test Mode	802.11b Mode / Tx Channel 1, 11
Test Site	Test chamber
Measurement Method	Radiated

Channel : 1 CH(2412 MHz)

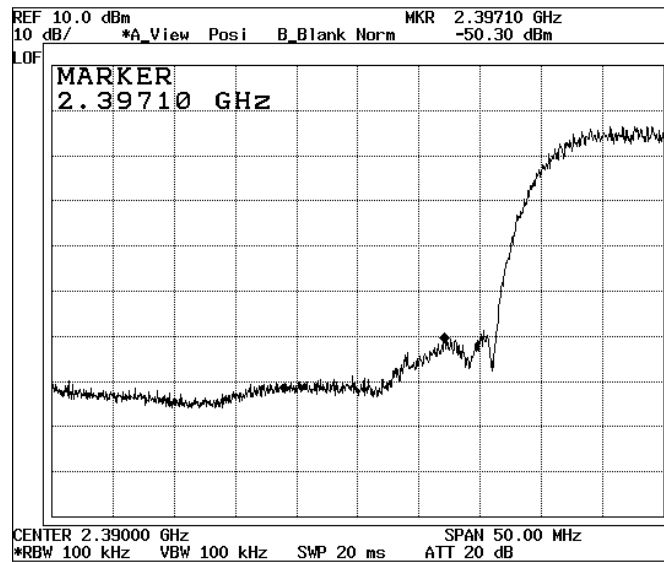

Channel : 11 CH(2462 MHz)



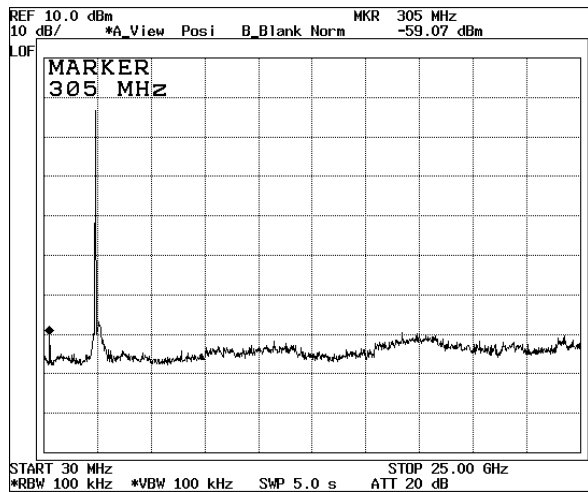
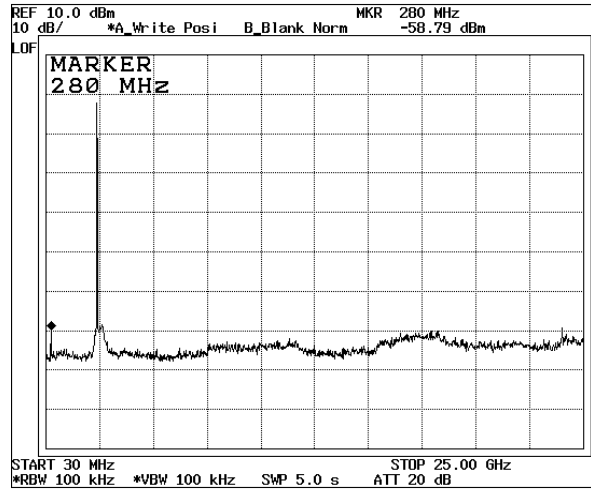
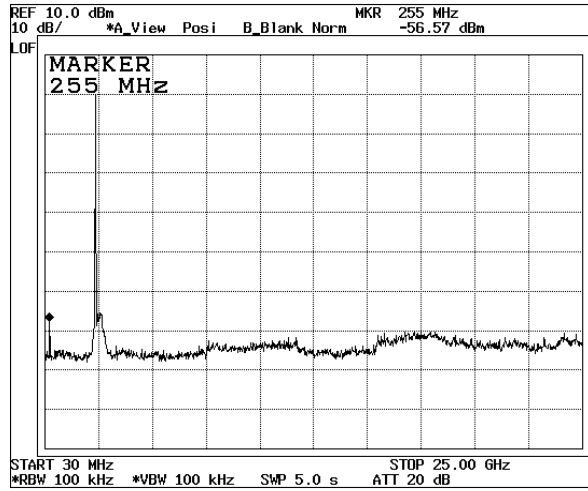

Product	EB07
Test Item	Band Edge
Test Mode	802.11g Mode / Tx Channel 1, 11
Test Site	Test chamber
Measurement Method	Radiated

Channel : 1 CH(2412 MHz)

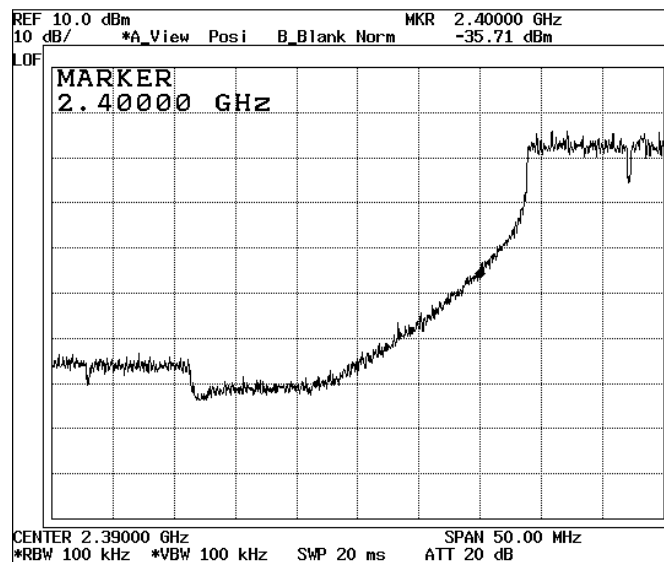

Channel : 11 CH(2462 MHz)

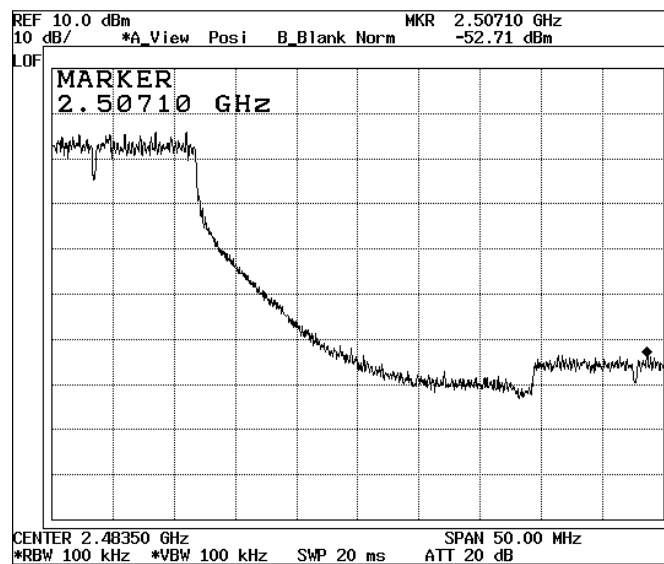

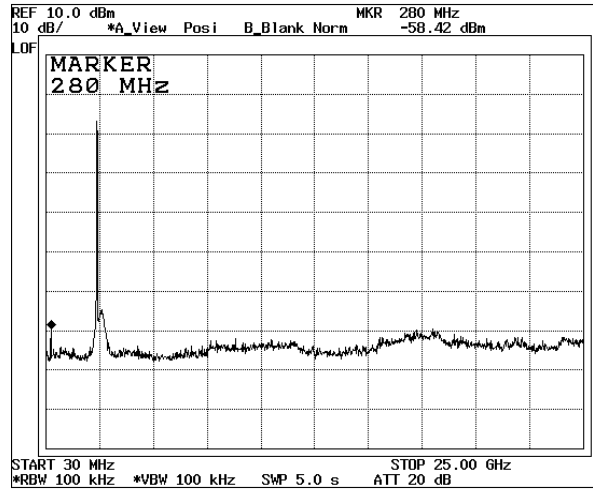
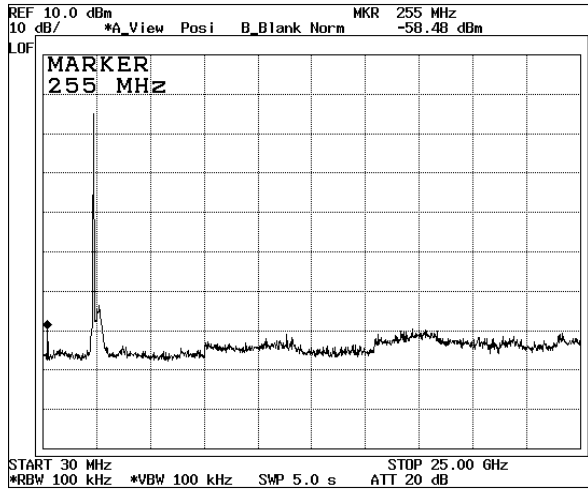

## 6dB Band

### ◆ Test Equipment

The following test equipment are used during the test:

Item	Equipment	Manufacturer	Model no/Serial No.	Last Cal.
1	Spectrum Analyzer	ADVANTEST	R3273 / 95090431	Oct.26, 2010
2	RF ROOM			

*Note : All equipment upon which need to calibrated are with calibration period of 1 year.*

### ◆ Test Setup

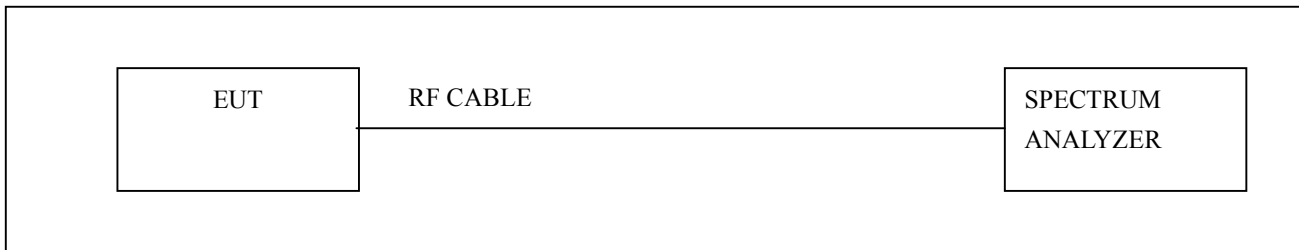

### ◆ Limits

(a) Operation under the provisions of this Section is limited to frequency hopping and digitally modulated intentional radiators that comply with the following provisions :

(2) systems using digital modulation techniques may operate in the 902-928 MHz, 2400-2483.5 MHz, and 5725-5850 MHz bands. The minimum 6 dB bandwidth shall be at least 500 kHz.

### ◆ Test Procedure

The transmitter output is connected to the Spectrum analyzer. The Spectrum analyzer is set to the 6dB Band(Occupied Bandwidth). According to FCC CFR Title 47 Part 15 Subpart C Section 15.247

Test result

Product	EB07
Test Item	6dB Band
Test Mode	802.11b Mode / Transmit
Test Site	RF Room
Measurement Method	Conducted

Channel No.	Frequency (MHz)	Measure Level (MHz)	Limit (KHz)	Result
1	2412	12.3	>500	Pass
6	2437	12.2	>500	Pass
11	2462	12.3	>500	Pass

Channel 1

Channel 6

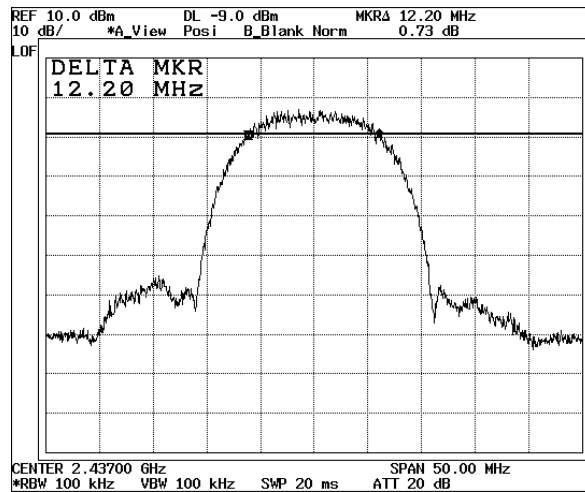
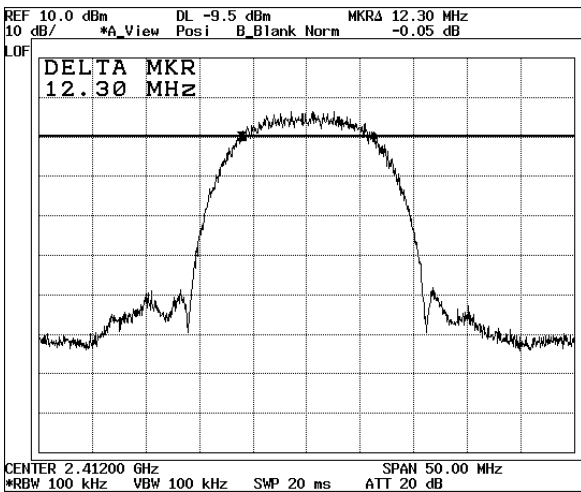

Channel 11

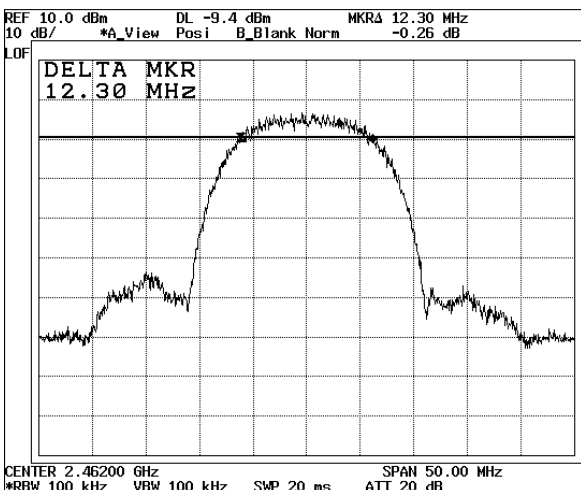

Test result

Product	EB07
Test Item	6dB Band
Test Mode	802.11g Mode / Transmit
Test Site	RF Room
Measurement Method	Conducted

Channel No.	Frequency (MHz)	Measure Level (MHz)	Limit (KHz)	Result
1	2412	16.60	>500	Pass
6	2437	16.55	>500	Pass
11	2462	16.55	>500	Pass

Channel 1

Channel 6

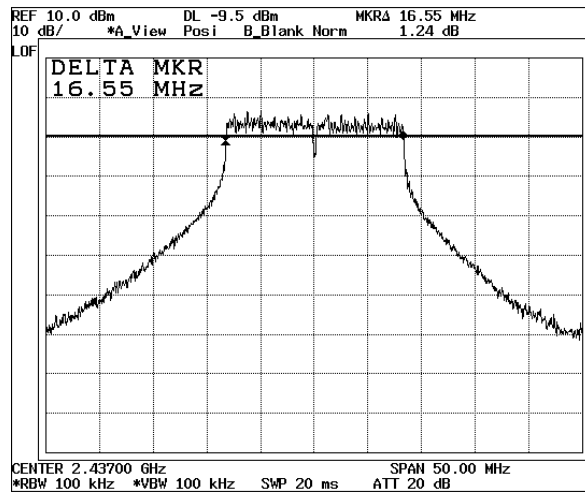
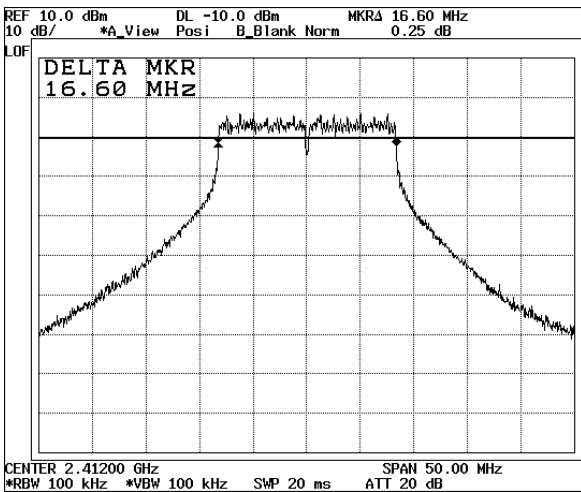

Channel 11

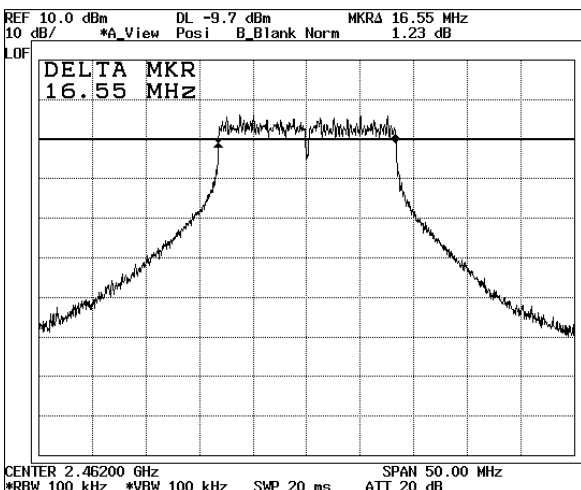

## Power Density

### ◆ Test Equipment

The following test equipment are used during the test:

Item	Equipment	Manufacturer	Model no/Serial No.	Last Cal.
1	Spectrum Analyzer	ADVANTEST	R3273 / 95090431	Oct. 26, 2010
2	RF ROOM			

*Note : All equipment upon which need to calibrated are with calibration period of 1 year.*

### ◆ Test Setup

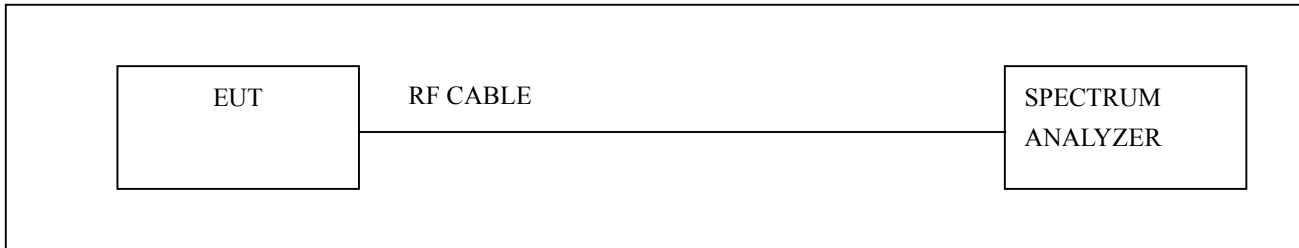

### ◆ Limits

Section 15.247 (e) For digitally modulated systems, the power spectral density conducted from the intentional radiator to the antenna shall not be greater than 8 dBm in any 3 kHz band during any time interval of continuous transmission. This power spectral density shall be determined in accordance with the provisions of paragraph (v) of this section. The same method of determining the conducted output power shall be used to determine the power spectral density.

### ◆ Test Procedure

The transmitter output is connected to the Spectrum analyzer. The Spectrum analyzer is set to the 6dB Band(Occupied Bandwidth). According to FCC CFR Title 47 Part 15 Subpart C Section 15.247



Test result

Product	EB07
Test Item	Power Density
Test Mode	802.11b Mode / Transmit
Test Site	RF Room
Measurement Method	Conducted

Channel No.	Frequency (MHz)	Measure Level (dBm)	Limit (dBm)	Result
1	2412	-16.94	< 8	Pass
6	2437	-16.87	< 8	Pass
11	2462	-16.99	< 8	Pass

Channel 1

Channel 6

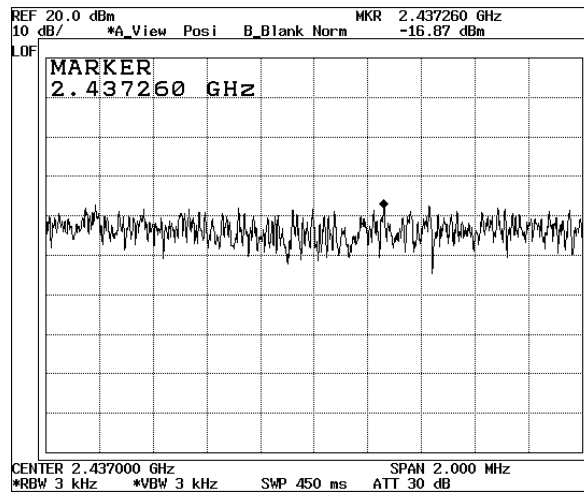
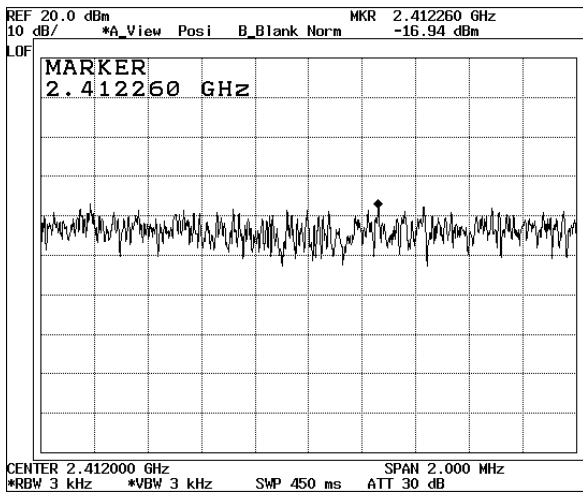

Channel 11

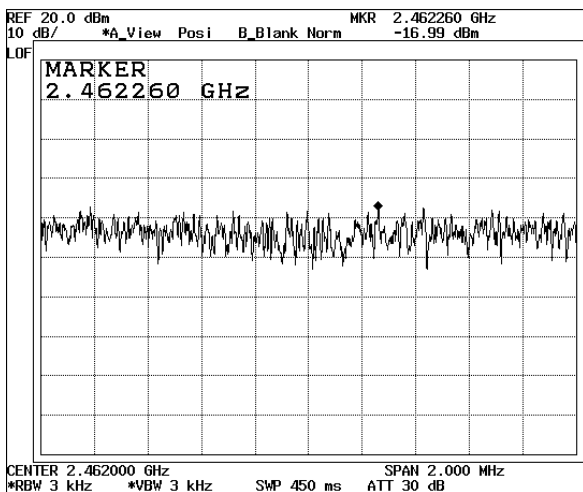

Note : Measurement level = reading level + correct factor

Test result

Product	EB07
Test Item	Power Density
Test Mode	802.11g Mode / Transmit
Test Site	RF Room
Measurement Method	Conducted

Channel No.	Frequency (MHz)	Measure Level (dBm)	Limit (dBm)	Result
1	2412	-17.49	< 8	Pass
6	2437	-17.82	< 8	Pass
11	2462	-17.92	< 8	Pass

Channel 1

Channel 6

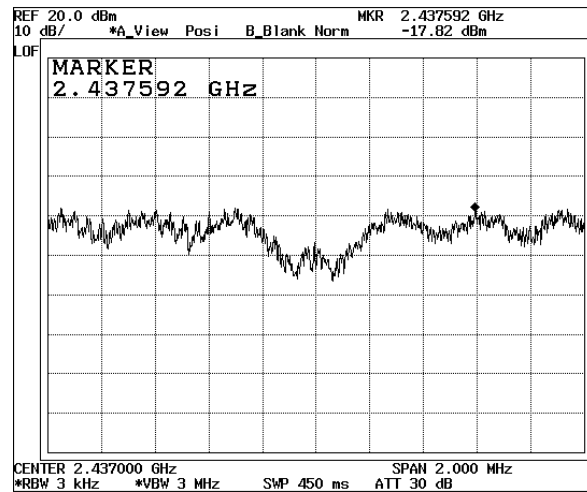
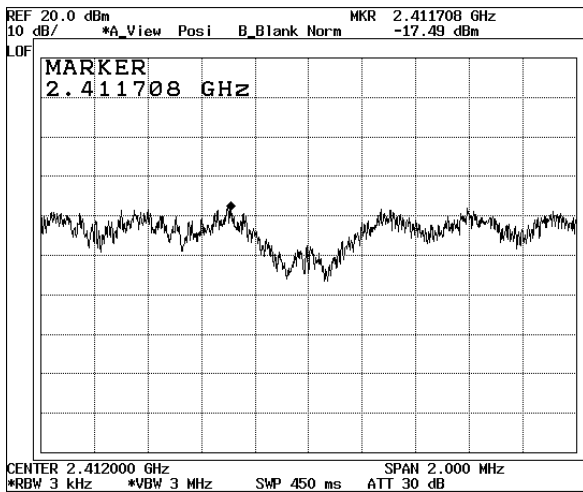

Channel 11

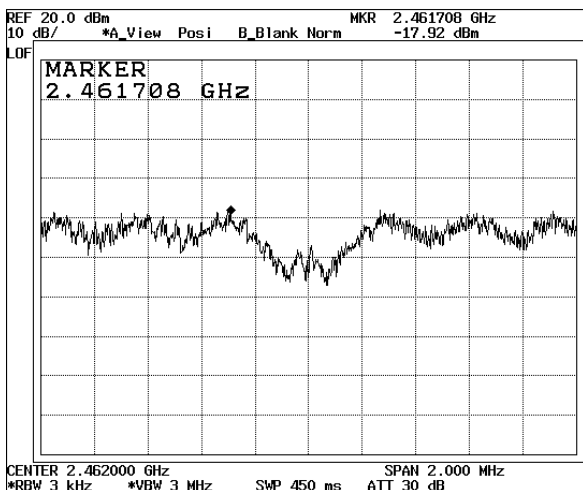

Note : Measurement level = reading level + correct factor

### Antenna requirements

#### **According to FCC 47 CFR 15.203**

“an intentional radiator antenna shall be designed to ensure that no antenna other than that furnished by the responsible party can be used with the device. The use of a permanently attached or an antenna that uses a unique coupling to the intentional radiator shall be considered sufficient to comply with the provisions of this section”

- \* The antenna of this EUT is a permanently attached.
- \* The EUT complies with the requirement of 15.203

