

TO: Reviewing Engineer

DATE: 5 November 2002

The newest Test Report was submitted to reflect new plot formats (more legible than in the first report submitted).

Marianne Bosley



**MET Laboratories, Inc.** *Safety Certification - EMI - Telecom Environmental Simulation*

914 WEST PATAPSCO AVENUE ! BALTIMORE, MARYLAND 21230-3432 ! PHONE (410) 354-3300 ! FAX (410) 354-3313



November 5, 2002

Multispectral Solutions, Inc.  
202 Perry Parkway  
Gaithersburg, MD 20874

Reference: SPIDER 650  
FCC ID: QCJSPDR650

Dear Mr. Robert Fontana:

Enclosed is the EMC Test Report for the Multispectral Solutions, Inc. SPIDER 650. The Multispectral Solutions, Inc. SPIDER 650 was tested to the requirements of the FCC Rules and Regulations, Part 15 Subpart F, of Title 47 of the CFR, for a Part 15 Ultra-Wideband Device.

Thank you for using the testing services of MET Laboratories. If you have any questions regarding these results or if MET can be of further assistance to you, please feel free to contact me. We appreciate your business and look forward to working with you again soon.

Kindest Regards,  
MET LABORATORIES, INC.

Marianne T. Bosley  
Documentation Department

Enclosures: (\Multispectral Solutions, Inc.\EMC12906-FCC511.rpt)  
DOCTEM-23 Jan 02

Certificates and reports shall not be reproduced except in full, without the written permission of MET Laboratories, Inc. While use of the National Voluntary Laboratory Accreditation Program (NVLAP) letters or the NVLAP Logo in this report reflects the MET Accreditation under the NVLAP Program, these letters, logo, or Statements do not claim product endorsement by NVLAP or any Agency of the U.S. Government.



## **Electro-Magnetic Compatibility**

### **Test Report**

for the

**Multispectral Solutions, Inc.**  
**SPIDER 650**

### **Tested Under**

FCC Part 15 Subpart F  
Section 15.511  
Title 47 of the CFR  
for Ultra-Wideband Operation

**MET REPORT: EMC12906-FCC511**

November 5, 2002

### **PREPARED FOR:**

Multispectral Solutions, Inc.  
20300 Century Boulevard  
Gaithersburg, MD 20874

### **PREPARED BY:**

MET Laboratories, Inc.  
914 West Patapsco Avenue  
Baltimore, Maryland 21230-3432

---

**Copyright 2002, MET Laboratories, Inc.**

This report shall not be reproduced except in full, without the express written consent of MET Laboratories, Inc., nor shall this report, or any copy thereof be provided to a competitor of MET Laboratories, Inc.



## Electro-Magnetic Compatibility

### Test Report

for the

**Multispectral Solutions, Inc.**

**SPIDER 650**

### Tested Under

FCC Part 15 Subpart F  
Section 15.511  
Title 47 of the CFR  
for Ultra-Wideband Operation

**MET REPORT: EMC12906-FCC511**

November 5, 2002

### PREPARED FOR:

Multispectral Solutions, Inc.  
20300 Century Boulevard  
Gaithersburg, MD 20874

Christopher R. Harvey, Director  
Electromagnetic Compatibility Testing

Marianne T. Bosley  
Report Writer

**Engineering Statement:** The measurements shown in this report were made in accordance with the procedures indicated, and the emissions from this equipment were found to be within the limits applicable. I assume full responsibility for the accuracy and completeness of these measurements, and for the qualifications of all persons taking them. It is further stated that upon the basis of the measurements made, the equipment tested is capable of operation in accordance with the requirements of Part 15, Subpart F, Section 15.511, of the FCC Rules under normal use and maintenance.

Liming Xu  
Project Engineer

Gregory M. Czumak  
Project Engineer



## Table of Contents

I.	Executive Summary	1
A.	Purpose of Test	2
B.	Executive Summary	2
II.	General	4
A.	Test Site	5
B.	Description of Test Sample	5
C.	General Test Setup	5
D.	Mode of Operation	5
E.	Modifications	7
F.	Disposition of Test Sample	7
III.	Electromagnetic Compatibility Antenna Requirements	8
A.	Antenna Evaluation Criteria	9
IV.	Electromagnetic Compatibility Emissions Requirements	10
A.	AC Line Conducted Emissions	11
B.	UWB Bandwidth	14
C.	Operational Limitations	16
D.	Cease Operation Provision Requirements	17
E.	Average Radiated Emissions - Broadband	18
F.	Average Radiated Emissions - Narrowband	25
G.	Peak Radiated Emissions	30
V.	Labeling & Instructional Manual Requirements	32
VI.	Test Equipment	35
VII.	Certification Information - 47 CFR Part 2	37



### List of Tables

Table 1.	Summary of Test Results .....	v
Table 2.	Summary of Test Data .....	v
Table 3.	EUT Compliance .....	2
Table 4.	References .....	3
Table 5.	Limits for Conducted Emissions from Intentional Radiators - §15.207(a) .....	11
Table 6.	Limits for Radiated Emissions from Intentional Radiators - §15.209(a) .....	18
Table 7.	Radiated Emissions Results - Average Broadband Measurements(low) .....	18
Table 8.	Limits for Radiated Emissions (RBW=1MHz) .....	19
Table 9.	Radiated Emissions Results - Average Broadband Measurements(hi) .....	21
Table 10.	Limits for Radiated Emissions (RBW>=1kHz) .....	25
Table 11.	Radiated Emissions Results - Average Narrowband Measurements .....	25
Table 12.	Radiated Emissions Results - Peak Measurements .....	30
Table 13.	Test Equipment for Intentional Radiators - §15.511 .....	36

### List of Figures

Figure 1.	Test Configuration .....	6
Figure 2.	FCC Intentional Radiators Tests Setup Photo .....	24



## List of Terms and Abbreviations

AC	Alternating Current
Cal	Calibration
<i>d</i>	Measurement Distance
dB	Decibels
dBFA	Decibels above one microamp
dBV	Decibels above one microvolt
dBFA/m	Decibels above one microamp per meter
dBV/m	Decibels above one microvolt per meter
DC	Direct Current
E	Electric Field
DSL	Digital Subscriber Line
ESD	Electrostatic Discharge
EUT	Equipment Under Test
<i>f</i>	Frequency
FCC	Federal Communications Commission
CISPR	Comite International Special des Perturbations Radioelectriques (International Special Committee on Radio Interference)
GRP	Ground Reference Plane
H	Magnetic Field
HCP	Horizontal Coupling Plane
Hz	Hertz
IEC	International Electrotechnical Commission
kHz	kilohertz
kPa	kilopascal
kV	kilovolt
LISN	Line Impedance Stabilization Network
MHz	Megahertz
FH	microhenry
FF	microfarad
Fs	microseconds
NEBS	Network Equipment-Building System
OATS	Open Area Test Site
PRF	Pulse Repetition Frequency
RF	Radio Frequency
RMS	Root-Mean-Square
TWT	Traveling Wave Tube
V/m	Volts per meter
VCP	Vertical Coupling Plane



### Summary of Test Results

These tests were conducted on a sample of the equipment for the purpose of demonstrating compliance with Part 15, Subpart F, Section 15.511. All tests were conducted using measurement procedure ANSI C63.4-1992, CISPR 16-1: 1993, and CFR 47 Part 15, Subpart F.

Type of Submission/Rule Part:	Original Filing/Part 15
EUT:	Multispectral Solutions, Inc. Pre-Production Unit
FCC ID:	QCJSPDR650
Equipment Code:	UWB
UWB Bandwidth:	6020 - 6699 MHz

**Table 1.**

### Summary of Test Data

Name of Test	FCC Rule Part/Section	Results
Conducted Emissions (If AC)	15.207(a)	N/A
Radiated Emissions	15.209(a)	Complies
UWB bandwidth	15.511(a)	Complies
Operational Limitations	15.511(b)	Applicant has been advised of these requirements
Cease Operation Provision	15.511(c)	N/A
Broadband Radiated Emissions - low and high	15.511(d)	Complies
Narrowband Radiated Emissions	15.511(e)	Complies
Peak Radiated Emissions	15.511(f); 15.521(e)	Complies
Labeling Requirements	15.511(g)	Applicant has been advised of these requirements

**Table 2.**





---

## **I. Executive Summary**

---



I. Executive Summary

A. Purpose of Test

An EMC evaluation to determine compliance of the SPIDER-650 ShortPulse Digital RADAR with the requirements of Part 15, Subpart F, Section 15.511 was conducted. (All references are to the most current version of Title 47 of the Code of Federal Regulations in effect). In accordance with §2.1033, the following data is presented in support of the Certification of the SPIDER-650 ShortPulse Digital RADAR. Multispectral Solutions, Inc. should retain a copy of this document should be kept on file for at least five years after the manufacturing of the SPIDER-650 ShortPulse Digital RADAR has been permanently discontinued.

B. Executive Summary

The following tests were performed in accordance with Purchase Order and Agreement with Multispectral Solutions, Inc.

Table with 3 columns: Specifications, Description, Compliance. Rows include: Title 47 of the CFR, Part 15, Subpart C, §15.207(a) - Conducted Emissions Requirements - N/A; Title 47 of the CFR, Part 15, Subpart C and F, §15.209(a) - Radiated Emissions Requirements - Complies; Title 47 of the CFR, Part 15, Subpart F, §15.511(a) - Ultra-Wideband Bandwidth Requirements - Complies; Title 47 of the CFR, Part 15, Subpart F, §15.511(b) - Operational Limitations - Applicant Notified of Requirements; Title 47 of the CFR, Part 15, Subpart F, §15.511(c) - Cease Operation Provision Requirement - N/A; Title 47 of the CFR, Part 15, Subpart F, §15.511(d) - Broadband Radiated Emissions - low and high Requirements - Complies; Title 47 of the CFR, Part 15, Subpart F, §15.511(e) - Narrowband Radiated Emissions Requirements - Complies; Title 47 of the CFR, Part 15, Subpart F, §15.511(f); §15.521(e) - Peak Radiated Emissions Requirements - Complies; Title 47 of the CFR, Part 15, Subpart F, §15.511(g) - Electromagnetic Compatibility - Labeling Requirements - Applicant Notified of Requirements

Table 3. EUT Compliance



**I. Executive Summary**

The EUT, as supplied to MET Laboratories, complied with the requirements stated in this test report.

References	Description
ANSI-C63.4:1992	Methods and Measurements of Radio-Noise Emissions from Low-Voltage Electrical And Electronic Equipment in the Range of 9 kHz to 40 GHz
FCC 47CFR, Chapter 1, Part 2	Title 47 Code of Federal Regulations Part 2 - Frequency Allocations and Radio Treaty Matters; General Rules and Regulations
FCC 47CFR, Chapter 1, Part 15	Title 47 Code of Federal Regulations Part 15 - Radio Frequency Devices

**Table 4. References**



---

## II. General

---



## II. General

### A. Test Site

All testing was conducted at MET Laboratories, Inc., 914 West Patapsco Avenue, Baltimore, Maryland 21230-3432. Radiated Emissions measurements were performed inside of a Semi Anechoic Chamber. In accordance with §2.948(a)(2), a complete site description is filed with the Commission's Laboratory in Columbia, Maryland. MET Laboratories has been accredited by the National Voluntary Laboratory Accreditation Program (Lab Code: 100273-0)

### B. Description of Test Sample

The SPIDER 650 utilizes short pulse, or ultra wideband (UWB), technology to determine the presence of, and distance to, an object within its field-of-view. The unit measures the time-of-flight of a pulse transmitted from its transmit antenna, reflected off an object, and returned to its receive antenna. Utilizing a sensitive, high-speed detector, measurements are made to nanosecond precision allowing the unit to achieve an accuracy and resolution of approximately one (1) foot.

The unit is intended for operation by law enforcement, fire and rescue officials, scientific research institutes, public utilities, commercial mining companies, construction companies and industrial entities.

Due to the nature of the EUT, its intended use and market, it is considered a Class A Digital Device (peripheral) subject to Verification.

### C. General Test Configuration

The EUT is connected to DC power (3 to 30 volt range) and an RS-232 serial interface through a DB-9 connector on the side of the unit. The EUT operates only in one configuration, the pulse repetition frequency (prf) is 30 Hz, and is not adjustable.

### D. Mode of Operation and Monitoring Method

The Multispectral Solutions, Inc. SPIDER 650 was configured in accordance with the manufacturer's instructions and was operated as follows for all testing contained in this report unless stated otherwise:

For testing purposes, the EUT was activated by sending a command to it via an attached RS-232 serial interface and any terminal software package. When power is applied, the unit responds to serial commands and is activated by typing either "G" ("Go" for a single measurement) or "R" ("Repeat" for multiple measurements). All other commands are used only to control receiver sensitivity.

If the unit is properly operating, it sends received data back to the user via its RS-232 link. If a "G" is typed, the unit responds with a single burst of ASCII data. If an "R" is typed, the unit continually sends ASCII data back to the user. If the unit does not respond with ASCII data via its serial interface, it is not performing according to the manufacturer's intended operation.



## II. General

### Frequency determining parameters

The highest frequency employed in §15.33 to determine the frequency range over which radiated emissions are made were based on the center frequency,  $f_c$ , unless a higher frequency was generated within the UWB device. For measuring emission levels, the spectrum were investigated from the lowest frequency generated in the UWB, without going below 9 kHz, up to the frequency range shown in Section 15.33(a) of the CFR 47 or up to  $f_c + 3/(\text{pulse width in seconds})$ , whichever was higher. There is no requirement to measure emissions beyond 40 GHz provided  $f_c$  was less than 10 GHz; beyond 100 GHz if  $f_c$  was at or above 10 GHz and below 30 GHz; or beyond 200 GHz if  $f_c$  was at or above 30 GHz.

The center frequency  $f_c$  was found to be 6359.5 MHz.

The pulse width of the EUT was 2.5 ns.

Therefore, the highest frequency to be measured was 40 GHz.

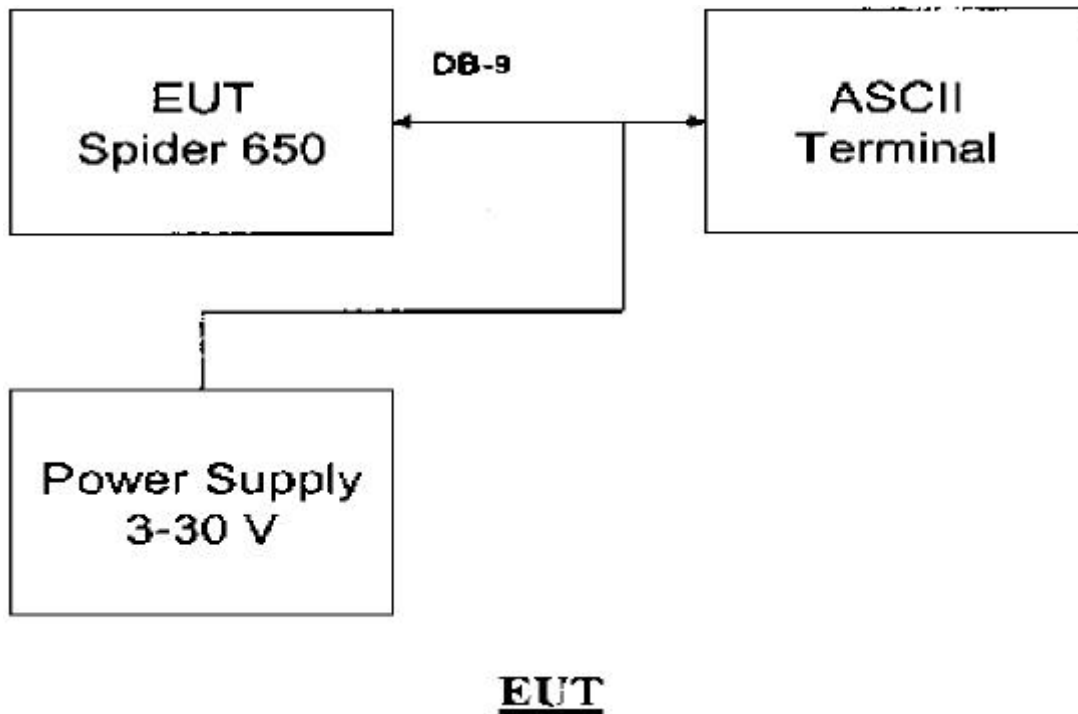

Figure 1. Test Configuration



**II. General**

**EUT**

Reference to Test Configuration	Description/Nomenclature	Model #	Serial #
EUT	Short Pulse	Spider 650	001

**Support Equipment**

Reference to Test Configuration	Description/Nomenclature	Manufacturer	Model #
Power Supply	DC power source 3-30V	Numerous	Numerous
ASCII Terminal	Computer with RS-232 interface	Numerous	Numerous

**Port and Cables**

Ref ID	Port Name on EUT	Type of Cable or reason for no cable	How many by default?	Length (m)	Shielded?	Termination Box ID & Port ID
1	DB-9	Custom (for power & RS-232) - see manual	1	N/A	No	N/A

**E. Modifications**

No modifications were made during testing.

**F. Disposition of Test Sample**

Returned to:

Multispectral Solutions, Inc.  
20300 Century Boulevard, Suite 175  
Germantown, MD 20874





---

### **III. Electromagnetic Compatibility Antenna Requirements**

---



### III. Electromagnetic Compatibility Antenna Requirements

#### A. Antenna Evaluation Criteria

**Requirements:** The structure and application of the EUT were analyzed to determine compliance with Section 15.203 of the Rules. Section 15.203 states that the subject device must meet at least one of the following criteria:

- A. Antenna be permanently attached to the unit.
- B. Antenna must use a unique type of connector to attach to the EUT.
- C. Unit must be professionally installed. Installer shall be responsible for verifying that the correct antenna is employed with the unit.

**See Photograph in Confidential Exhibits**

**Results:** The Multispectral Solutions, Inc. SPIDER 650 meets the criteria of this rule by virtue of having a permanently attached internal antenna, and is not accessible by the user. The EUT is therefore compliant with §15.203.



---

## **IV. Electromagnetic Compatibility Emissions Requirements**

---



**IV. Electromagnetic Compatibility Emission Requirements**

**A. AC Line Conducted Emissions**

**Requirements:** The EUT shall meet the limits shown below:

Frequency Range (MHz)	Conducted Limit (dBuV)	
	Quasi-peak	Average
0.15 - 0.5	66 to 56*	56 to 46*
0.5 - 5	56	46
5 - 30	60	50

**Table 5.Limits for Intentional Radiators from FCC Part 15 §15.207(a)** \*Decreases with the logarithm of the frequency

**Test Equipment:** Test equipment for this test is in Section VI of this report.

**Test Configuration:** The EUT was installed SETUP inside a shielded enclosure. The EUT was situated such that the back of the EUT was 0.4 m from one wall of the shielded enclosure, and the remaining sides of the EUT were no closer than 0.8 m from any other conductive surface. The EUT was powered from a 50 S/50 FH Line Impedance Stabilization Network (LISN).

**Procedure:** The EMC receiver scanned the frequency range from 150 kHz to 30 MHz. Conducted Emissions measurements were made in accordance with ANSI C63.4-1992 "Methods and Measurements of Radio-Noise Emissions from Low-Voltage Electrical and Electronic Equipment in the Range of 9 kHz to 40 GHZ." The measurements were performed over the frequency range of 0.15 MHz to 30 MHz using a 50 S/50 FH LISN as the input transducer to an EMC/Field Intensity Meter. The tests were conducted in a RF shielded enclosure.

**Results:** The EUT is battery-powered. Therefore, the requirements of §15.207 of the FCC Rules and Regulations does not apply to this device.

**Test Engineer:** N/A

**Test Date:** N/A



#### IV. Electromagnetic Compatibility Emission Requirements

**Subject:** Conducted Emissions - Voltage, Data Plot

**Port:** AC Power Phase

**Requirements:** FCC Part 15 Subpart C, §15.207(a)

**Results:** Equipment is battery-powered, and therefore, the specifications of §15.207(a) do not apply.

**Test Engineer:** N/A

**Test Date:** N/A



#### IV. Electromagnetic Compatibility Emission Requirements

**Subject:** Conducted Emissions - Voltage, Data Plot

**Port:** AC Power Neutral

**Requirements:** FCC Part 15 Subpart C, §15.207(a)

**Results:** Equipment is battery powered, and therefore, the specifications of §15.207(a) do not apply.

**Test Engineer:** N/A

**Test Date:** N/A



## IV. Electromagnetic Compatibility Emission Requirements

### B. Ultra-Wideband Bandwidth - §15.511(a)

**Requirements:** The UWB bandwidth of a UWB system operating under this section must be contained between 1990 MHz and 10,600 MHz.

**Test Equipment:** Test equipment for this test is in Section VI of this report.

**Test Configuration /Procedure:** Emissions were measured similar to the procedure used in the Radiated Emissions test section. Due to the extremely wide nature of UWB emissions, special considerations were taken to make the bandwidth measurements. The RBW was set to 1MHz and the VBW to 3 MHz. The test distance was 1 meter. Emissions from the EUT between 1990 MHz and 10600 MHz were maximized by rotating the EUT and adjusting the height of the measurement antenna.

**Results:** The EUT was found to comply with the requirements of §15.511(a). A bandwidth plot follows:  $f_L = 6.020$  GHz,  $f_H = 6699$  MHz,  $f_M = 6.425$  MHz, and UWB Bandwidth = 679 MHz

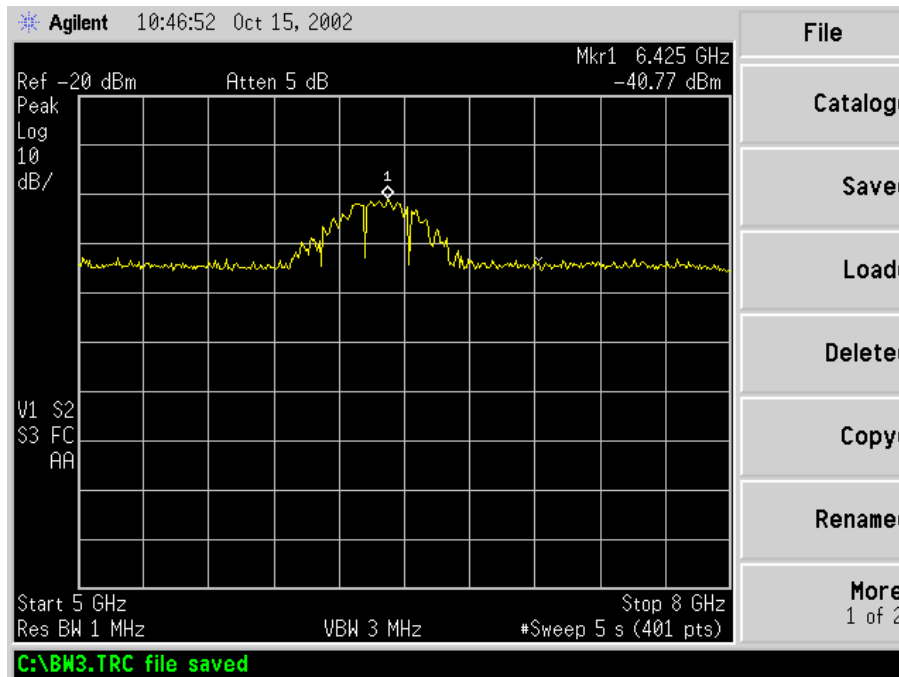



**IV. Electromagnetic Compatibility Emission Requirements**

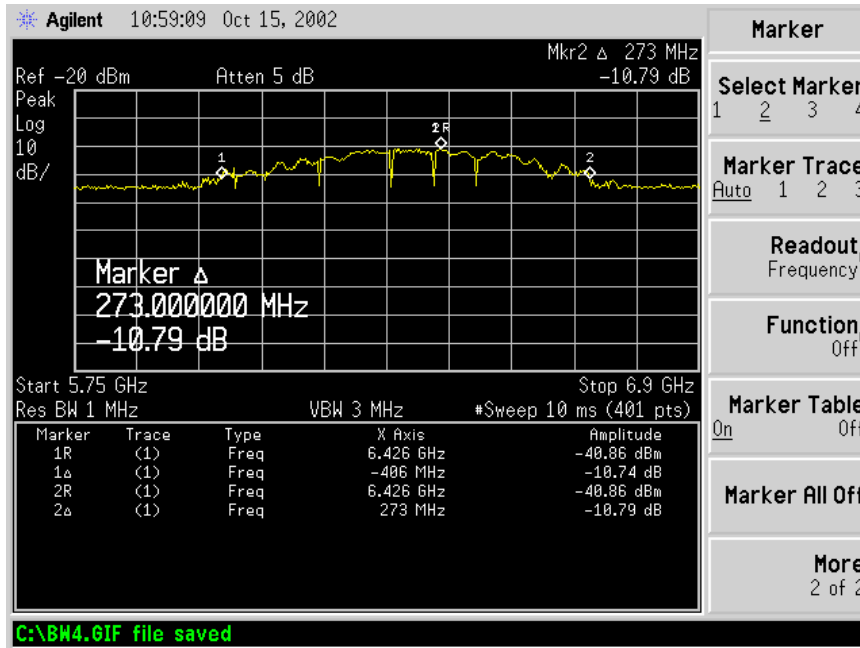

**Test Engineer:** Gregory M. Czumak

**Test Date:** October 15, 2002





## IV. Electromagnetic Compatibility Emission Requirements

### C. Operational Limitations - §15.511(b) - Operation under this section is limited to the following:

**Requirements:** §15.511(b)(1) - Through-wall imaging systems operated by law enforcement, fire or emergency rescue organization. - **Not applicable to this device.**

§15.511(b)(2) - Fixed surveillance systems operated by law enforcement, fire or emergency rescue organizations or by manufacturers licensees, petroleum licensees or power licensees as defined in Section 90.7 of this CFR Chapter.

**Applicant has been informed of requirement.**

§15.511(b)(3) - Parties operating under the provisions of this section must be eligible for licensing under the provisions of Part 90 of this Chapter.

**Applicant has been informed of requirement**

§15.511(b)(4) - The operation of imaging systems under this section requires coordination with the FCC, as detailed in §15.525.

**Applicant has been informed of requirement**



## IV. Electromagnetic Compatibility Emission Requirements

### D. Cease Operation Provision Requirements - §15.511(c)

**Requirements:** A through-wall imaging system shall contain a manually operated switch that causes the transmitter to cease operation within 10 seconds of being released by the operator. In addition, it is permissible to operate an imaging system by remote control provided the imaging system ceases transmission within 10 seconds of the remote switch being released by the operator.

**Results:** N/A

**Test Engineer:** N/A

**Test Date:** N/A



**IV. Electromagnetic Compatibility Emission Requirements**

**E. Average Radiated Emissions - Broadband - §15.209(a); §15.511(d)**

**Low - Below 960 MHz -**

**Requirements:** The EUT shall meet the limits shown below for emissions at or below 960 MHz:

Frequency (MHz)	Limit (microvolts/meter) @ 3 m
30 - 88	100**
88 - 216	150**
216 - 960	200**
Above 960	500

**Table 6. Limits for Spurious Emissions from Intentional Radiators from FCC Part 15 § 15.209(a)**

\*\*Except perimeter protection systems operating under paragraph (g), fundamental emissions from intentional radiators operating under this Section shall not be located in the frequency bands 54-72 MHz, 76-88 MHz, 174-216 MHz or 470-806 MHz. However, operation within these frequency bands is permitted under other sections of this Subpart.

Freq. (MHz)	EUT Azimuth (Degrees)	Antenna Polarity (H/V)	Antenna HEIGHT (m)	Uncorrected Amplitude (dBuv)	Antenna Correction Factor (dB) (+)	Cable Loss (dB) (+)	Distance Correction Factor (dB) (-)	Corrected Amplitude (dBuv)	Limit (dBuv)	Margin (dB)
30	0	H	1.2	4.85	4.90	1.30	10.46	0.59	39	-38.41
30	0	V	1.2	4.81	5.40	1.30	10.46	1.05	39	-37.95
130.57	0	H	1.2	11.75	7.52	2.51	10.46	11.32	43.5	-32.18
130.57	0	V	1	10.2	7.81	2.51	10.46	10.06	43.5	-33.44
178.5	0	H	1	12.07	8.91	2.85	10.46	13.37	43.5	-30.13
178.5	0	V	1	11.3	9.04	2.85	10.46	12.73	43.5	-30.77
184.37	0	H	1.2	10.72	9.44	2.89	10.46	12.59	43.5	-30.91
184.37	0	V	1.2	8.9	9.19	2.89	10.46	10.52	43.5	-32.98
937	0	H	1	7.8	23.60	5.86	10.46	26.80	46.4	-19.60
937	0	V	1	8.06	22.64	5.86	10.46	26.10	46.4	-20.30
949.25	0	H	1	8.12	23.78	5.96	10.46	27.40	46.4	-19.00
949.25	0	V	1	8.82	22.88	5.96	10.46	27.20	46.4	-19.20

**Table 7. Broadband Radiated Emissions Results (low)**



**IV. Electromagnetic Compatibility Emission Requirements**

**High - Above 960 MHz -**

**Requirements:** Radiated Emissions above 960 MHz from a device operating under this section shall not exceed the following average limits when measured using a RBW of 1 MHz.

Frequency in MHz	EIRP in dBm
960 - 1610	-53.3
1610 - 1990	-51.3
1990 - 10600	-41.3
Above 10600	-51.3

**Table 8. Limits for Radiated Emissions (RBW = 1MHz)**

**Test Equipment:** Test equipment for this test is in Section VI of this report.

**Test Conditions/ Procedure:** The EUT was placed on a 0.8 m high wooden table inside a shielded enclosure. An antenna was placed near the EUT and measurements of frequencies and amplitudes of field strengths were recorded for reference during final measurements. For final radiated testing, measurements were performed in a semi-anechoic chamber or OATS. Measurements were performed with the EUT oriented in 3 orthogonal axis and rotated 360 degrees to determine worst case orientation for maximum emissions.

Measurements of the radiated field were made with the measurement antenna located at a distance of 1 meter from the EUT unless specified otherwise in the measurement results. The antenna was adjusted between 1 m and 4 m in height above the ground plane fro maximum meter reading at each test frequency. The antenna -to-EUT azimuth was varied from zero to 360 degrees during the measurement to find the maximum field strength readings. The antenna polarization was varied



## IV. Electromagnetic Compatibility Emission Requirements

(horizontal to vertical) during the measurements to find the maximum field strength readings. The EUT, where intended for tabletop use, was placed on a table whose top is 0.8m above the ground plane. The table was constructed of non-conductive materials. Its dimensions were 1m X 1.5m. Equipment setup followed the guidelines of ANSI C63.4:1992.

For frequencies from 30 MHz to 1 GHz, measurements were made using a quasi-peak detector with a 120 kHz bandwidth. For frequencies above 1 GHz, peak measurements were made with a resolution bandwidth of 1 MHz and a video bandwidth equal to or greater than 1MHz. Results were compared to the limit mathematically corrected pursuant to Section 15.521(g). Broadband average measurements were made with  $RBW = 1\text{MHz}$ ,  $VBW \geq RBW$ , using the RMS average detector available on the spectrum analyzer. Narrowband average measurements were made with  $RBW \geq 1\text{kHz}$ ,  $VBW \geq RBW$ , using the RMS average detector available on the spectrum analyzer.

The “signal substitution method”, as used by the FCC Laboratory, was employed. Once the emission under investigation was maximized, the reading shown on the analyzer was recorded. The cable was removed at the antenna and connected to a signal generator. The output of the signal generator was adjusted until the level of the signal on the analyzer was equal to the recorded reading. This adjusted output level now takes cable loss and pre-amp gain into account, and is added to the measurement horn antenna factor in order to obtain the field strength. Because measurements were performed @ 1 meter, the field strength was adjusted to obtain the 3 meter equivalent field strength.

For pre-scanning, the EMI receiver scanned the frequency range from 30 MHz to 10 GHz, per §15.33(a)(4) to obtain an Emission profile of the EUT. For each point of measurement, the turntable was rotated, the positions of the interface cables were varied, and the antenna height was varied between 1 m and 4 m, in order to find the maximum radiated Emissions. Measurements were taken using this technique with the antenna in two polarizations: horizontal and vertical.

### Frequency determining parameters

The highest frequency employed in §15.33 to determine the frequency range over which radiated emissions are made were based on the center frequency,  $f_c$ , unless a higher frequency was generated within the UWB device. For measuring emission levels, the spectrum were investigated from the lowest frequency generated in the UWB, without going below 9 kHz, up to the frequency range shown in Section 15.33(a) of the CFR 47 or up to  $f_c + 3/(\text{pulse width in seconds})$ , whichever was higher. There is no requirement to measure emissions beyond 40 GHz provided  $f_c$  was less than 10 GHz; beyond 100 GHz if  $f_c$  was at or above 10 GHz and below 30 GHz; or beyond 200 GHz if  $f_c$  was at or above 30 GHz.

**Calculation of Limit:** The EIRP limit is mathematically converted to the equivalent 3 m field strength using the following equation from §15.521(g):  $E(\text{dBuV/m}) = P(\text{dBm EIRP}) + 95.2$



**IV. Electromagnetic Compatibility Emission Requirements**

**Results:** The EUT was found to comply with the emissions requirements of §15.209(a) and §15.511(d). There were no measurable emissions between the highest reported emission in the table below and 40 GHz. The measurement noise floor is well below the specified limit.

Frequency (GHz)	Antenna Polarity (H/V)	Antenna HEIGHT (m)	Uncorrected Amplitude (dBuv)	Antenna Correction Factor (dB) (+)	System Gain (dB) (-)	Distance Correction Factor (dB) (-)	Corrected Amplitude (dBuv)	Limit (dBuv)	Margin (dB)
1.001	V	1	46.8	22.90	36.80	9.5	23.40	41.9	-18.50 <sup>a</sup>
1.7506	V	1	40.6	25.80	33.60	9.5	23.30	43.9	-20.60 <sup>b</sup>
6.377	V	1	41.1	34.50	27.10	9.5	39.00	53.9	-14.90 <sup>c</sup>
10.64	V	1	35.6	38.40	28.60	9.5	35.90	43.9	-8.00 <sup>d</sup>

**Table 9. Results - Average RE Broadband - Hi (§15.511d)**

**NOTES:**

- a. cw type emission
- b. cw type emission
- c. fundamental emission
- d. noise floor



# IV. Electromagnetic Compatibility Emission Requirements

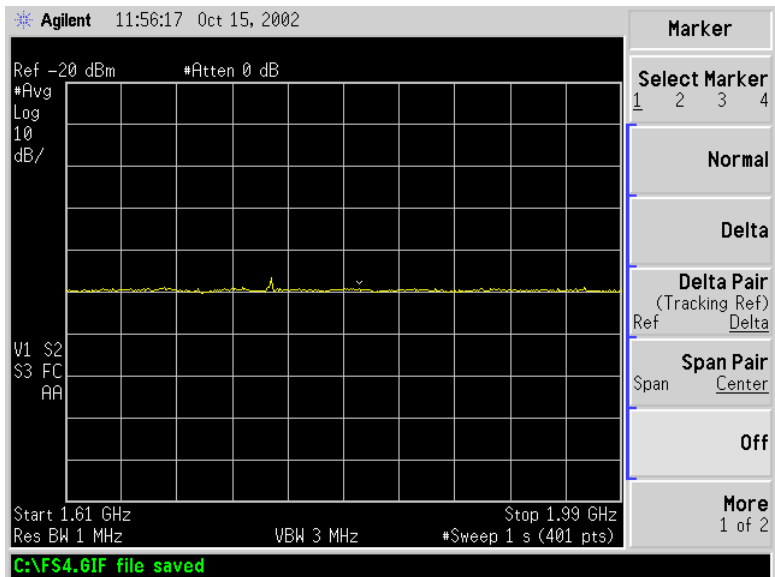
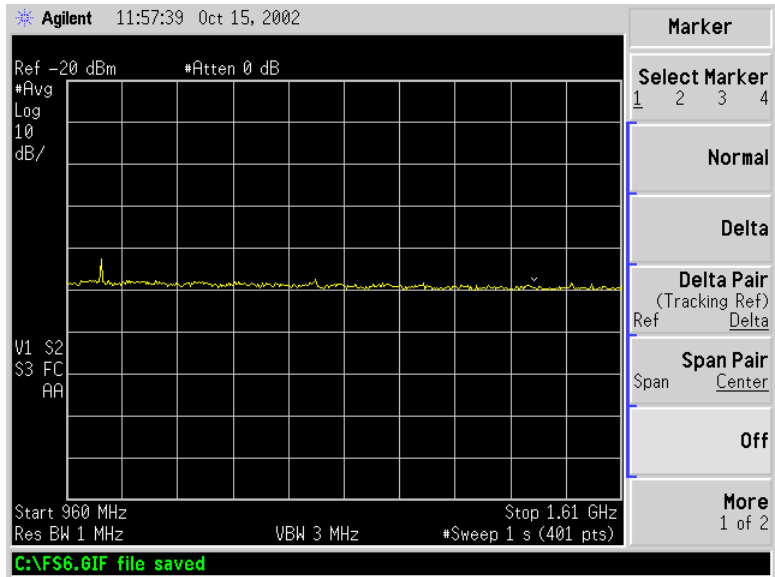



# IV. Electromagnetic Compatibility Emission Requirements

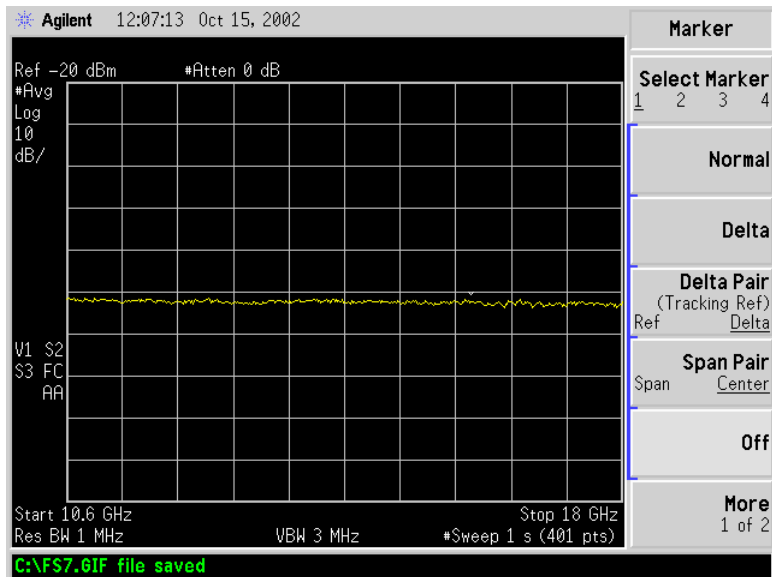
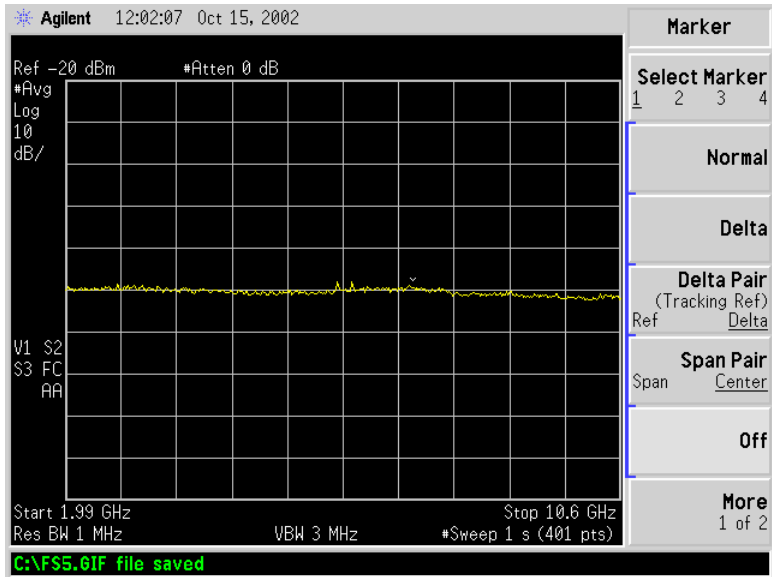



## IV. Electromagnetic Compatibility Emission Requirements

**Photograph:**

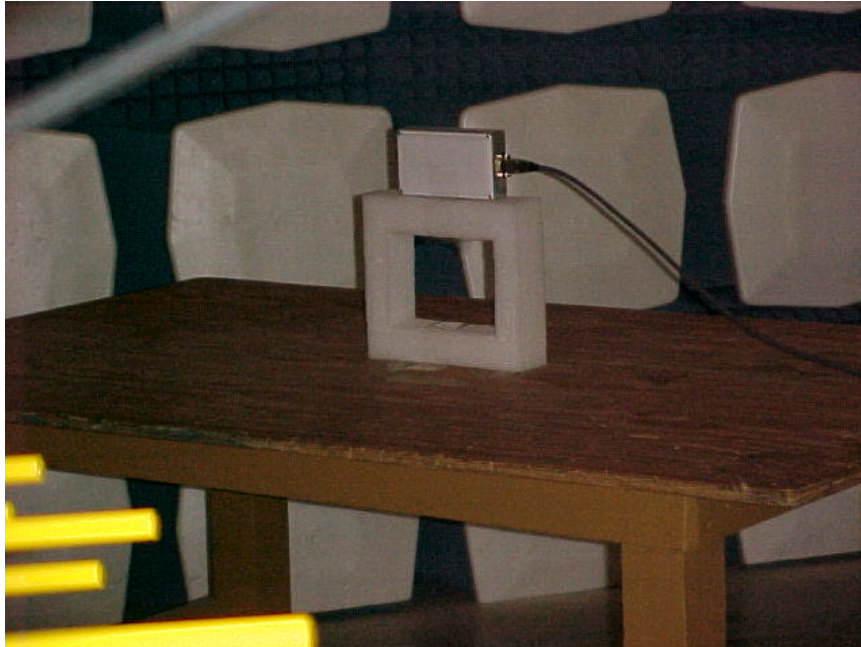

**Figure 2. FCC Intentional Radiators Test Setup Photo**

**Test Engineers:** Liming Xu  
Gregory Czumak

**Test Date:** 10/15/2002



**IV. Electromagnetic Compatibility Emission Requirements**

**F. Average Radiated Emissions - Narrowband - §15.511(e)**

**Requirements:** Radiated Emissions above 960 MHz from a device operating under this section shall not exceed the following average limits when measured using a RBW of no less than 1 kHz.

Frequency in MHz	EIRP in dBm
1164 - 1240	-63.3
1559 - 1610	-63.3

**Table 10. Limits for Radiated Emissions (RBW >= 1kHz)**

**Test Equipment:** Test equipment for this test is in Section VI of this report.

**Calculation of Limit:** The EIRP limit is mathematically converted to the equivalent 3 m field strength using the following equation from §15.521(g):  **$E(\text{dBuV/m}) = P(\text{dBm EIRP}) + 95.2$**

**Results:** The EUT was found to comply with the requirements of §15.511(e). There were no intentional emissions above the measurement noise floor within these bands. The measurement system noise floor is well below the specified limit.

Frequency (GHz)	Antenna Polarity (H/V)	Antenna HEIGHT (m)	Uncorrected Amplitude (dBuV)	Antenna Correction Factor (dB) (+)	System Gain (dB) (-)	Distance Correction Factor (dB) (-)	Corrected Amplitude (dBuV)	Limit (dBuV)	Margin (dB)
1.171	V	1	15.9	23.40	31.80	9.5	-2.00	31.9	-33.90 <sup>a</sup>
1.176	V	1	13	23.40	31.00	9.5	-4.10	31.9	-36.00 <sup>b</sup>
1.227	V	1	12	23.60	31.20	9.5	-5.10	31.9	-37.00 <sup>c</sup>
1.563	V	1	15.3	24.80	31.50	9.5	-0.90	31.9	-32.80 <sup>d</sup>
1.575	V	1	12.2	24.80	30.50	9.5	-3.00	31.9	-34.90 <sup>e</sup>
1.95	V	1	11.8	26.90	28.40	9.5	0.80	31.9	-31.10 <sup>f</sup>
2.3	V	1	11.8	27.60	30.00	9.5	-0.10	31.9	-32.00 <sup>g</sup>

**Table 11. Results - Average RE Narrowband - Hi (§15.511e)**

**NOTES:**

- a. N.F., RBW=3kHz, VBW=30kHz
- b. N.F., RBW=1kHz, VBW=10kHz
- c. N.F., RBW=1kHz, VBW=10kHz
- d. N.F., RBW=3kHz, VBW=30kHz
- e. N.F., RBW=1kHz, VBW=10kHz
- f. N.F., RBW=1kHz, VBW=10kHz
- g. N.F., RBW=1kHz, VBW=10kHz



### IV. Electromagnetic Compatibility Emission Requirements

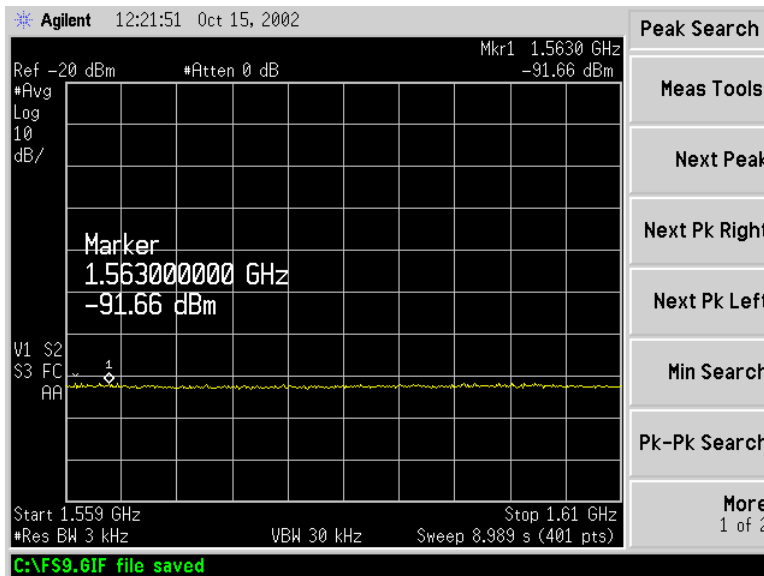
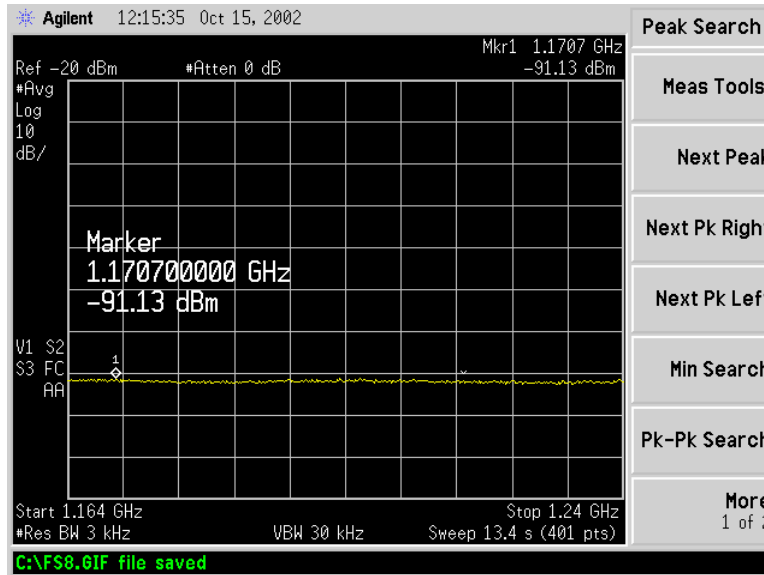



### IV. Electromagnetic Compatibility Emission Requirements

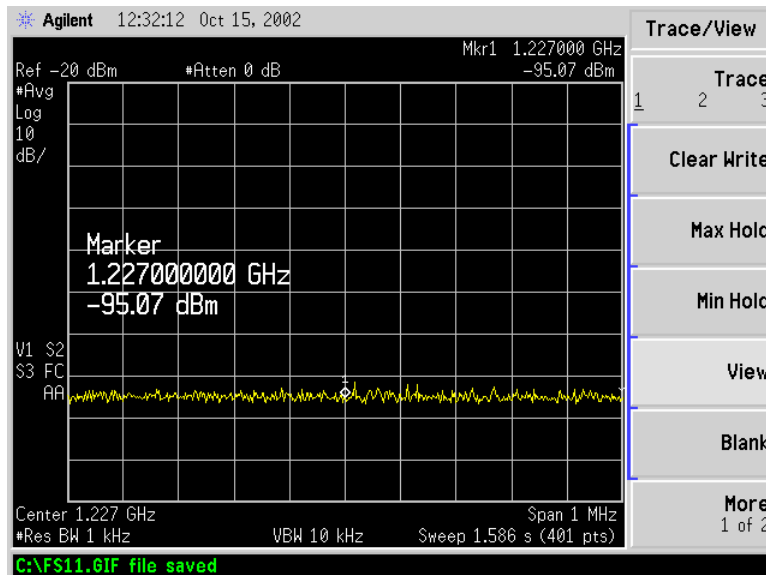
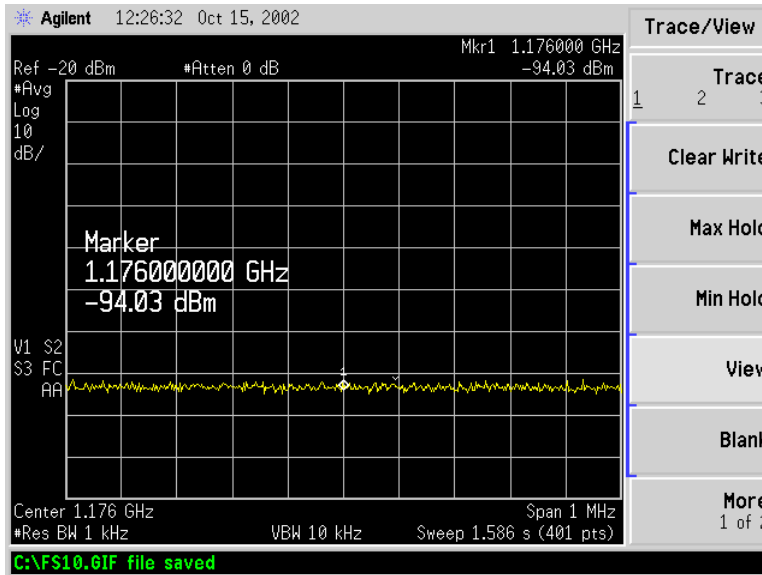



### IV. Electromagnetic Compatibility Emission Requirements

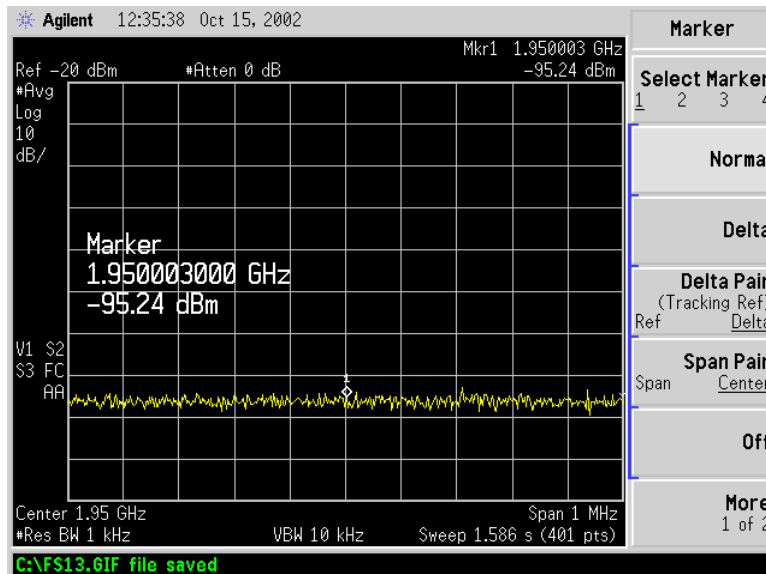
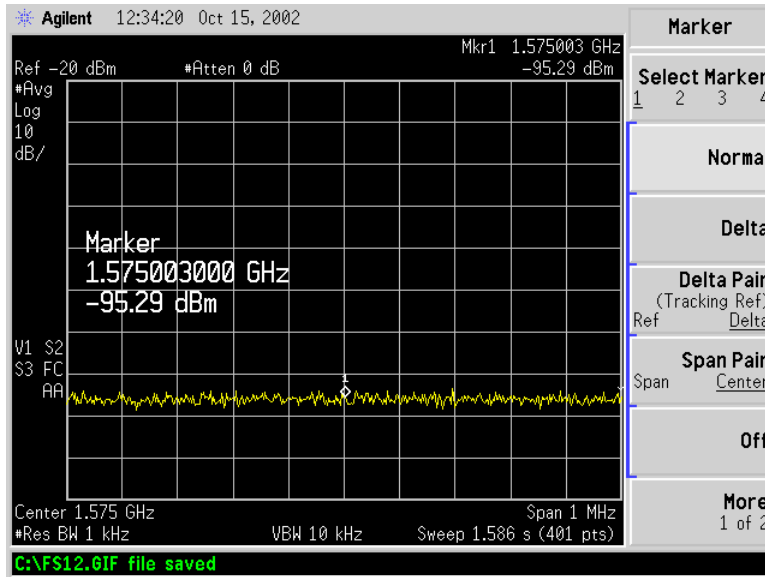



**IV. Electromagnetic Compatibility Emission Requirements**

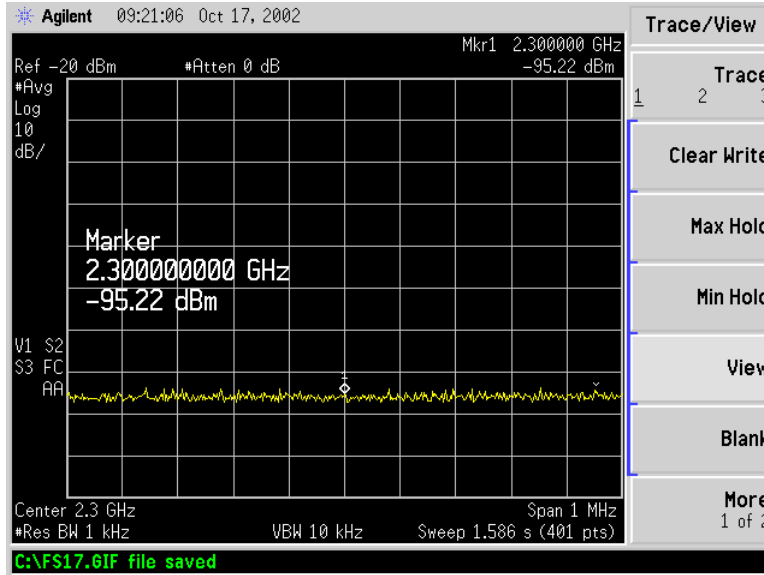

**Test Engineer:** Gregory M. Czumak

**Test Date:** October 15, 2002



**IV. Electromagnetic Compatibility Emission Requirements**

**G. Peak Radiated Emissions - §15.511(f)**

**Requirements:** There is a limit on the peak level of the emissions contained within a 50 MHz bandwidth centered on the frequency at which the highest radiated emissions occurs,  $f_M$ . That limit is 0 dBm EIRP. It is acceptable to employ a different RBW, and a correspondingly different peak emission limit, following the procedures in §15.521.

**Test Equipment:** Test equipment for this test is in Section VI of this report.

**Calculation of Limit:** Pursuant to §15.521(g), the peak EIRP limit =  $20\log(1\text{MHz}/50) = -34\text{dBm}$ . The equivalent field strength at 3m =  $(-34) + 95.2 = 61.2 \text{ dBuV/m}$ .

**Results:** The EUT was found to comply with the requirements of §15.511(f).

Freq. (GHz)	Antenna Polarity (H/V)	Antenna HEIGHT (m)	Uncorrected Amplitude (dBuv)	Antenna Correction Factor (dB (+))	System Gain (dB (-))	Distance Correction Factor (dB (-))	Corrected Amplitude (dBuv)	Limit (dBuv)	Margin (dB)
6.421	V	1	61.5	34.40	29.50	9.5	56.90	61.2	-4.30

Table 12. Results - Peak Radiated Emissions (§15.511f)

## IV. Electromagnetic Compatibility Emission Requirements



**Test Engineer:** Gregory M. Czumak

**Test Date:** October 15, 2002



---

## **V. Labeling and Instruction Manual Requirements**

---

## V.. Labeling and Instruction Manual Requirements

### §15.511(g) Labeling and Instruction Manual Requirements.

Imaging systems operating under these provisions shall bear the following or similar statement, as adjusted for the limitations mentioned earlier in this report (§15.511(b), in a conspicuous location on the device:

“Operation of this device is restricted to law enforcement, fire and rescue officials, public utilities, and industrial entities. Operation by any other party is a violation of 47 U.S.C. 301 and could subject the operator to serious legal penalties.”

### § 15.19 Labeling requirements.

- (a) In addition to the requirements in Part 2 of this chapter, a UWB device subject to certification shall be labeled as follows:

The following statement shall appear in a **conspicuous location on the device**:

This device complies with Part 15 of the FCC Rules. Operation is subject to the following two conditions: (1) This device may not cause harmful interference, and (2) this device must accept any interference received, including interference that may cause undesired operation.

- (1) Where a device is constructed in two or more sections connected by wires and marketed together, the statement specified under paragraph (a) of this section is required to be affixed only to the main control unit.
- (2) When the device is so small or for such use that it is not practicable to place the statement specified under paragraph (a) of this section on it, the information required by this paragraph shall be placed in a prominent location in the instruction manual or pamphlet supplied to the user or, alternatively, shall be placed on the container in which the device is marketed. However, the FCC identifier or the unique identifier, as appropriate, must be displayed on the device.

### § 15.21 Information to user to appear in the manual.

The users manual or instruction manual for an intentional or unintentional radiator shall caution the user that changes or modifications not expressly approved by the party responsible for compliance could void the user's authority to operate the equipment

## V. Labeling and Instruction Manual Requirements

### § 15.105 Information to the user to appear in the manual.

- (a) For a Class B digital device or peripheral, the instructions furnished the user shall include the following or similar statement, placed in a prominent location in the text of the manual:

Note: This equipment has been tested and found to comply with the limits for a Class B digital device, pursuant to Part 15 of the FCC Rules. These limits are designed to provide reasonable protection against harmful interference when the equipment is operated in a residential environment. This equipment generates, uses, and can radiate radio frequency energy and, if not installed and used in accordance with the instruction manual, may cause harmful interference to radio communications. However, there is no guarantee that interference will not occur in a particular installation. If this equipment does cause harmful interference to radio or television reception, which can be determined by turning the equipment off and on, the user is encouraged to try to correct the interference by one or more of the following measures:

- Reorient or relocate the receiving antenna.
- Increase the separation between the equipment and receiver.
- Connect the equipment into an outlet on a circuit different from that to which the receiver is connected.
- Consult the dealer or an experienced radio/TV technician for help

---

## **VI. Test Equipment**

---

<b>VI. Test Equipment</b>
---------------------------

MET #	Equipment	Manufacturer	Model	Cal Date	Cal Due
1T4300	SEMI-ANECHOIC CHAMBER # 1	EMC TEST SYSTEMS	NONE	08/21/2002	08/21/2003
1T4303	ANTENNA; BILOG	SCHAFNER - CHASE EMC	CBL6140A	03/27/2002	03/27/2003
1T4302	EMI receiver	HP	85462A	10/17/2002	10/17/2003
1T-4102	Pre-Amp	HP	83017A		
1T-2665	Double-ridge waveguide antenna	EMCO	3115	3/3/02	3/3/03
	EMC Analyzer	Agilent	E7405A	7/12/02	7/12/03

**Table 13. Test Equipment for UWB Tests - Part 15 Subpart F**

Note: Functionally verified test equipment is verified at the time of testing.

---

**VII. Certification Information - 47 CFR Part 2**

---

## A. Certification Information

The following is extracted from Title 47 of the Code of Federal Regulations, Part 2, Subpart I — Marketing of Radio frequency devices:

### § 2.801 Radio-frequency device defined.

As used in this part, a radio-frequency device is any device which in its operation is capable of Emitting radio-frequency energy by radiation, conduction, or other means. Radio- frequency devices include, but are not limited to:

- (a) The various types of radio communication transmitting devices described throughout this chapter.
- (b) The incidental, unintentional and intentional radiators defined in Part 15 of this chapter.
- (c) The industrial, scientific, and medical equipment described in Part 18 of this chapter.
- (d) Any part or component thereof which in use emits radio-frequency energy by radiation, conduction, or other means.

### § 2.803 Marketing of radio frequency devices prior to equipment authorization.

- (a) Except as provided elsewhere in this chapter, no person shall sell or lease, or offer for sale or lease (including advertising for sale or lease), or import, ship or distribute for the purpose of selling or leasing or offering for sale or lease, any radio frequency device unless:
  - (1) In the case of a device subject to certification, such device has been authorized by the Commission in accordance with the rules in this chapter and is properly identified and labeled as required by §2.925 and other relevant sections in this chapter; or
  - (2) In the case of a device that is not required to have a grant of equipment authorization issued by the Commission, but which must comply with the specified technical standards prior to use, such device also complies with all applicable administrative (including verification of the equipment or authorization under a Declaration of Conformity, where required), technical, labeling and identification requirements specified in this chapter.
- (d) Notwithstanding the provisions of paragraph (a) of this section, the offer for sale solely to business, commercial, industrial, scientific or medical users (but not an offer for sale to other parties or to end users located in a residential environment) of a radio frequency device that is in the conceptual, developmental, design or pre-production stage is permitted prior to equipment authorization or, for devices not subject to the equipment authorization requirements, prior to a determination of compliance with the applicable technical requirements *provided* that the prospective buyer is advised in writing at the time of the offer for sale that the equipment is subject to the FCC rules and that the equipment will comply with the appropriate rules before delivery to the buyer or to centers of distribution.
- (e)(1) Notwithstanding the provisions of paragraph (a) of this section, prior to equipment authorization or determination of compliance with the applicable technical requirements any radio frequency device may be operated, but not marketed, for the following purposes and under the following conditions:

- (i) Compliance testing;
  - (ii) Demonstrations at a trade show provided the notice contained in paragraph (c) of this section is displayed in a conspicuous location on, or immediately adjacent to, the device;
  - (iii) Demonstrations at an exhibition conducted at a business, commercial, industrial, scientific or medical location, but excluding locations in a residential environment, provided the notice contained in paragraphs (c) or (d) of this section, as appropriate, is displayed in a conspicuous location on, or immediately adjacent to, the device;
  - (iv) Evaluation of product performance and determination of customer acceptability, provided such operation takes place at the manufacturer's facilities during developmental, design or pre-production states; or
  - (v) Evaluation of product performance and determination of customer acceptability where customer acceptability of a radio frequency device cannot be determined at the manufacturer's facilities because of size or unique capability of the device, provided the device is operated at a business, commercial, industrial, scientific or medical user's site, but not at a residential site, during the development, design or pre-production stages.
- (e)(2) For the purpose of paragraphs (e)(1)(iv) and (e)(1)(v) of this section, the term *manufacturer's facilities* includes the facilities of the party responsible for compliance with the regulations and the manufacturer's premises, as well as the facilities of other entities working under the authorization of the responsible party in connection with the development and manufacture, but not the marketing, of the equipment.
- (f) For radio frequency devices subject to verification and sold solely to business, commercial, industrial, scientific and medical users (excluding products sold to other parties or for operation in a residential environment), parties responsible for verification of the devices shall have the option of ensuring compliance with the applicable technical specifications of this chapter at each end user's location after installation, provided that the purchase or lease agreement includes a proviso that such a determination of compliance be made and is the responsibility of the party responsible for verification of the equipment.



**The following is extracted from Title 47 of the Code of Federal Regulations, Part 2, Subpart J — Equipment Authorization Procedures:**

**§ 2.901 Basis and Purpose**

- (a) In order to carry out its responsibilities under the Communications Act and the various treaties and international regulations, and in order to promote efficient use of the radio spectrum, the Commission has developed technical standards for radio frequency equipment and parts or components thereof. The technical standards applicable to individual types of equipment are found in that part of the rules governing the service wherein the equipment is to be operated.<sup>1</sup> In addition to the technical standards provided, the rules governing the service may require that such equipment be verified by the manufacturer or importer, be authorized under a Declaration of Conformity, or receive an equipment authorization from the Commission by one of the following procedures: certification or registration.
- (b) The following sections describe the verification procedure, the procedure for a Declaration of Conformity, or the procedures to be followed in obtaining certification from the Commission and the conditions attendant to such a grant, whichever is applicable.

**§ 2.907 Certification.**

- (a) Certification is an equipment authorization issued by the Commission, based on representation and test data submitted by the applicant.
- (b) Certification attaches to all units subsequently marketed by the grantee which are identical (see Section 2.908) to the sample tested except for permissive changes or other variations authorized by the Commission pursuant to Section 2.1043.

---

<sup>1</sup>In this case, the equipment is subject to the rules of Part 15. More specifically, the equipment falls under Subpart C (of Part 15), which deals with intentional radiators.

**§ 2.948 Description of measurement facilities.**

- (a) Each party making measurements of equipment that is subject to an equipment authorization under Part 15 or Part 18 of this chapter, regardless of whether the measurements are filed with the Commission or kept on file by the party responsible for compliance of equipment marketed within the U.S. or its possessions, shall compile a description of the measurement facilities employed.
  - (1) If the measured equipment is subject to the verification procedure, the description of the measurement facilities shall be retained by the party responsible for verification of the equipment.
    - (i) If the equipment is verified through measurements performed by an independent laboratory, it is acceptable for the party responsible for verification of the equipment to rely upon the description of the measurement facilities retained by or placed on file with the Commission by that laboratory. In this situation, the party responsible for the verification of the equipment is not required to retain a duplicate copy of the description of the measurement facilities.
    - (ii) If the equipment is verified based on measurements performed at the installation site of the equipment, no specific site calibration data is required. It is acceptable to retain the description of the measurement facilities at the site at which the measurements were performed.
  - (2) If the equipment is to be authorized by the Commission under the certification procedure, the description of the measurement facilities shall be filed with the Commission's Laboratory in Columbia, Maryland. The data describing the measurement facilities need only be filed once but must be updated as changes are made to the measurement facilities or as otherwise described in this section. At least every three years, the organization responsible for filing the data with the Commission shall certify that the data on file is current.

---

**END OF REPORT**

---