

SRSM.ENV_SENSOR.01 Manual

FCC ID: QCI-IDNMOD1

IC: 4302A-IDNMOD1

1. Connector definition

PIN Number	Name	Description
1	3V OUT	3.3V voltage output by the module
2	USB DP	USB signal
3	GND	Ground
4	USB DM	USB signal
5	MCU INT	Reserved
6	I2C SDA	Reserved
7	I2C SCL	Reserved
8	GND	Ground
9	UART TX	Reserved
10	UART RX	Reserved
11	5VM	5V power supply
12	5VM	5V power supply

2. Antenna Area

The sensing area of the antenna is shown in the figure below:

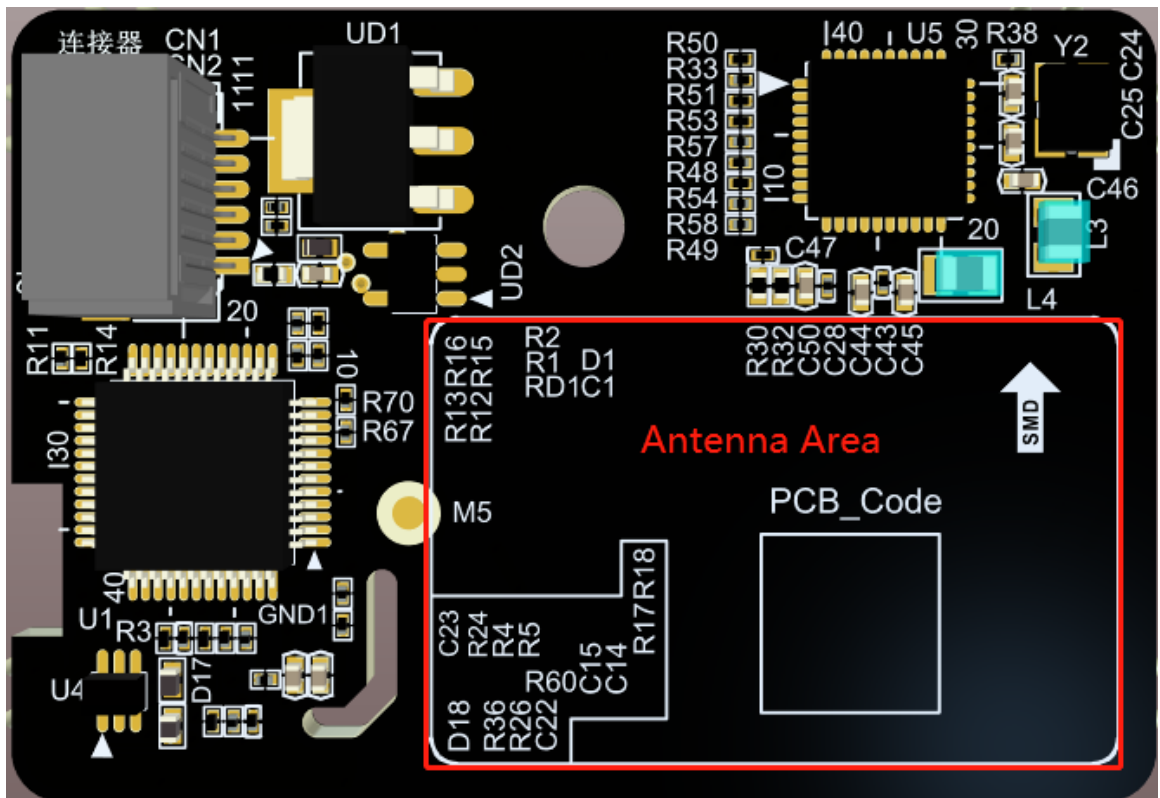

3. Instructions

After the USB2.0 host is connected to this module, NFC-related functions can be operated through the USB CCID interface.

4. Label

There will be a silkscreen of the module model on the PCB of the module

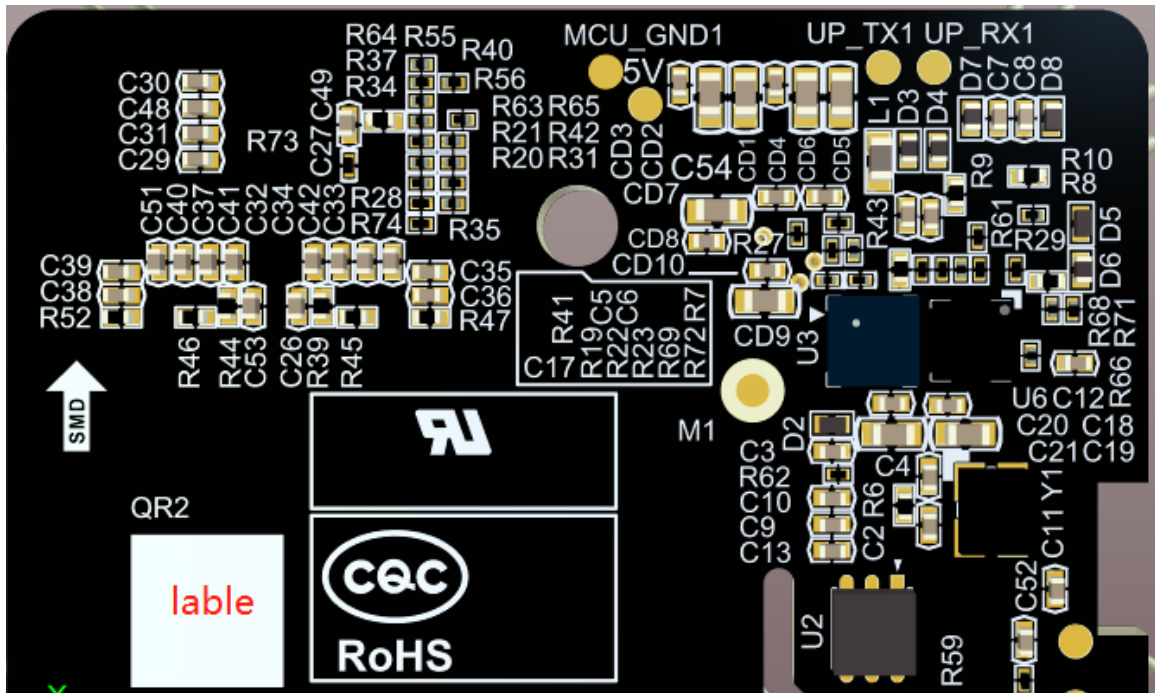

FCC warning:

Any Changes or modifications not expressly approved by the party responsible for compliance could void the user's authority to operate the equipment.

Note: This equipment has been tested and found to comply with the limits for a Class B digital device, pursuant to part 15 of the FCC Rules. These limits are designed to provide reasonable protection against harmful interference in a residential installation. This equipment generates uses and can radiate radio frequency energy and, if not installed and used in accordance with the instructions, may cause harmful interference to radio communications. However, there is no guarantee that interference will not occur in a particular installation. If this equipment does cause harmful interference to radio or television reception, which can be determined by turning the equipment off and on, the user is encouraged to try to correct the interference by one or more of the following measures:

- Reorient or relocate the receiving antenna.
- Increase the separation between the equipment and receiver.
- Connect the equipment into an outlet on a circuit different from that to which the receiver is connected.
- Consult the dealer or an experienced radio/TV technician for help.

This device complies with part 15 of the FCC Rules. Operation is subject to the following two conditions: (1) This device may not cause harmful interference, and (2) this device must accept any interference received, including interference that may cause undesired operation.

This equipment complies with RF radiation exposure limits set forth for an uncontrolled environment. This equipment should be installed and operated with a minimum distance of 20 centimeters between the radiator and your body.

The separate approval is required for all other operating configurations, including portable configurations with respect to Part 2.1093 and different antenna configurations.

Warning:

The module is limited to OEM installation ONLY

The antenna installation must be professional installation, and does not permit use of any antenna with the transmitter; the permitted types of antenna must be specified.

The module cannot be sold via retail to the general public or by mail order; it must be sold to authorized dealers or installers only.

The end product intended use is not for consumers and general public; rather device is generally for industrial/commercial use.

The installation shall be performed by trained licensed professionals, it uses specialized software and adjusts the best angles and orientations, which are difficult for ordinary people to do.

The module is limited to installation in mobile or fixed application.

The OEM integrator is responsible for ensuring the end-user has no manual instruction to remove or install module;

Modular approval allows installation in different end-use products by an original equipment manufacturer (OEM) with limited or no additional testing or equipment authorization for the transmitter function provided by the IDNMOD1. Specifically:

- No additional transmitter compliance testing is required if the module is operated with the antenna listed in the document below.
- No additional transmitter-compliance testing is required if the module is operated with the same general type of antenna (i.e. near-field segmented loop, circularly polarized patches) as those listed in this User's Guide and in the FCC filing for the IDNMOD1. Acceptable antennas must be of equal or less far field gain than the antenna previously authorized under the same FCC ID, and must have similar in band and out of band characteristics.

In addition, the end product must comply with all applicable FCC equipment authorizations, regulations, requirements and equipment functions not associated with the IDNMOD1. For example, compliance must be demonstrated to regulations for other transmitter components within the host product, to requirements for unintentional radiators (Part 15B), and to additional authorization requirements for the non-transmitter functions.

The OEM applying the IDNMOD1 is required to include all FCC and/or IC statements and warnings detailed in the following sections to the end product labeling (where specified) and in the finished product manual. The OEM must also strictly adhere to antenna and installation guidelines and MPE restrictions stated in this document.

The finished product manual must contain the following statement:

The host product shall use physical label stating "contains transmitter module
FCC ID: QCI-IDNMOD1" or "contains FCC ID: QCI-IDNMOD1"
IC: 4302A-IDNMOD1" or "contains IC: 4302A-IDNMOD1"

WARNING: The Federal Communications Commission warns that changes or modifications of the radio module within this device not expressly approved by SMART Technologies ULC. could void the user's authority to operate the equipment.

In the case where an OEM seeks class B (residential) limits for the host product, the finished product manual must contain the following statement:

Note: This equipment has been tested and found to comply with the limits for a Class B digital device, pursuant to part 15 of the FCC Rules. These limits are designed to provide reasonable protection against harmful interference in a residential installation. This equipment generates, uses and can radiate radio frequency energy and, if not installed and used in accordance with the instructions, may cause harmful interference to radio communications. However, there is no guarantee that interference will not occur in a particular installation. If this equipment does cause harmful interference to radio or television reception, which can be determined by turning the equipment off and on, the user is encouraged to try to correct the interference by one or more of the following measures:

- Reorient or relocate the receiving antenna.
- Increase the separation between the equipment and receiver.
- Connect the equipment into an outlet on a circuit different from that to which the receiver is connected.
- Consult the dealer or an experienced radio/TV technician for help.

In the case where an OEM seeks the lesser category of a Class B digital device for their finished product, the following statement must be included in the manual of the finished product:

Note: This equipment has been tested and found to comply with the limits for a Class B digital device, pursuant to part 15 of the FCC Rules. These limits are designed to provide reasonable protection against harmful interference when the equipment is operated in a commercial environment. This equipment generates, uses, and can radiate radio frequency energy and, if not installed and used in accordance with the instruction manual, may cause harmful interference to radio communications. Operation of this equipment in a residential area is likely to cause harmful interference in which case the user will be required to correct the interference at his expense.

A statement must be included on the exterior of the final OEM product which communicates that the device identified by the aforementioned FCC and Industry Canada ID numbers are contained within the product.

The OEM must include the following statements on the exterior of the finished product unless the product is too small (e.g. less than 4 x 4 inches):

This device complies with Part 15 of the FCC Rules. Operation is subject to the following two conditions: (1) this device may not cause harmful interference, and (2) this device must accept any interference received, including any interference that may cause undesired operation.

The user manual for the end product must include the following information in a prominent location:

To comply with FCC's RF radiation exposure requirements, the antenna(s) used for this transmitter must be installed such that a minimum separation distance of 20cm is maintained between the radiator (antenna) & user's/nearby people's body at all times and must not be co-located or operating in conjunction with any other antenna or transmitter

The IDNMOD1 is compatible with many varieties of antennas, but for purposes of modular certification with FCC, only one antenna was tested. IDNMOD1 users can have their own antenna and IDNMOD1 systems certified with FCC and IC.

In order to operate the IDNMOD1 under either FCC ID: QCI-IDNMOD1, the OEM must strictly follow these antenna guidelines:

- The OEM may operate only with the following antenna or antennas of the same type with maximum gain as shown:

PCB antenna with 0 dBi linear far field gain

- RF I/O interface to the antenna connector on the PCB shall be accomplished via a microstrip or stripline transmission line with characteristic impedance of 50 ohms +/- 10%. A custom coaxial pigtail may also be utilized to connect to the antenna in lieu of a connector.
- The connector on the OEM's PCB which interfaces to the antenna must be of a unique type to disable connection to a non-permissible antenna in compliance with FCC section 15.203. The following connectors are allowed:
- The OEM must professionally install the IDNMOD1 into its final environment to ensure that the conditions are met.

The minimum safe distance for people from the IDNMOD1 has been determined by conservative calculation to be less than 20 cm for the allowable antenna types. The end product User's Guide must include the following statement in a prominent location: To comply with FCC's RF radiation exposure requirements, the antenna(s) used for this transmitter must be installed such that a minimum separation distance of 20 cm is maintained between the radiator (antenna) & user's/nearby people's body at all times and must not be co-located or operating in conjunction with any other antenna or transmitter.

IC warning:

This device complies with Industry Canada licence-exempt RSS standard(s). Operation is subject to the following two conditions: (1) This device may not cause interference, and (2) This device must accept any interference, including interference that may cause undesired operation of the device.

L'émetteur/récepteur exempt de licence contenu dans le présent appareil est conforme aux CNR d'Innovation, Sciences et Développement économique Canada applicables aux appareils radio exempts de licence. L'exploitation est autorisée aux deux conditions suivantes :

- 1) L'appareil ne doit pas produire de brouillage;
- 2) L'appareil doit accepter tout brouillage radioélectrique subi, même si le brouillage est susceptible d'en compromettre le fonctionnement.