

TEST REPORT
DYNAMIC FREQUENCY SELECTION REQUIREMENTS
OF
FCC Part 15.407 Subpart E (UNII) & RSS-210 Issue 6

Redline Communications, Inc.
Model(s): AN-80i

MANUFACTURER: Redline Communications, Inc.
302 Town Centre Blvd, Suite 100
Markham, Ontario Canada L3R 0E8

TEST SITE: Elliott Laboratories, Inc.
684 W. Maude Ave
Sunnyvale, CA 94086

REPORT DATE: November 16, 2006

FINAL TEST DATE: November 6, 2006

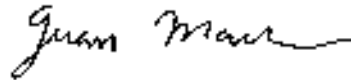

AUTHORIZED SIGNATORY: _____

Juan Martinez
Sr. EMC Engineer



Elliott Laboratories, Inc. is accredited by the A2LA, certificate number 2016-01, to perform the test(s) listed in this report. This report shall not be reproduced, except in its entirety, without the written approval of Elliott Laboratories, Inc.

TABLE OF CONTENTS

COVER PAGE.....1

TABLE OF CONTENTS2

LIST OF FIGURES AND TABLES.....3

SCOPE.....6

OBJECTIVE6

STATEMENT OF COMPLIANCE6

DEVIATIONS FROM THE STANDARD6

EQUIPMENT UNDER TEST (EUT) DETAILS7

 GENERAL.....7

 ENCLOSURE.....7

 MODIFICATIONS7

 SUPPORT EQUIPMENT.....8

 EUT INTERFACE PORTS8

 EUT OPERATION8

TEST RESULTS9

 TEST RESULTS SUMMARY – FCC PART 15 & RSS-210, CLIENT DEVICE (10 MHZ)9

 TEST RESULTS SUMMARY – FCC PART 15 & RSS-210, CLIENT DEVICE (20 MHZ)11

 TEST RESULTS SUMMARY – FCC PART 15 & RSS-210, CLIENT DEVICE (40 MHZ)13

 MEASUREMENT UNCERTAINTIES.....15

DFS TEST METHODS16

 RADIATED TEST METHOD16

DFS MEASUREMENT INSTRUMENTATION18

 RADAR GENERATION SYSTEM18

 CHANNEL MONITORING SYSTEM18

DFS MEASUREMENT METHODS20

 DFS RADAR DETECTION BANDWIDTH20

 DFS – CHANNEL CLOSING TRANSMISSION TIME AND CHANNEL MOVE TIME20

 DFS CHANNEL AVAILABILITY CHECK TIME20

 UNIFORM LOADING20

 TRANSMIT POWER CONTROL (TPC)21

SAMPLE CALCULATIONS.....22

 DETECTION PROBABILITY / SUCCESS RATE22

 THRESHOLD LEVEL22

APPENDIX A TEST EQUIPMENT CALIBRATION DATA.....23

APPENDIX B TEST DATA TABLES FOR RADAR DETECTION PROBABILITY FCC & RSS-210.....24

APPENDIX C TEST DATA TABLES AND PLOTS FOR CHANNEL CLOSING131

 FCC PART 15 SUBPART E & RSS-210 DATA131

 FCC PART 15 SUBPART E & RSS-210 DATA134

 FCC PART 15 SUBPART E & RSS-210 DATA137

APPENDIX D TEST DATA – CHANNEL AVAILABILITY CHECK FOR 10, 20, AND 40 MHZ140

APPENDIX E UNII DETECTION BANDWIDTH	144
APPENDIX F TEST DATA – UNIFORM LOADING.....	148
APPENDIX G ANTENNA SPECIFICATION SHEET	153
APPENDIX H TEST CONFIGURATION DIAGRAM	154

LIST OF FIGURES AND TABLES

Table 1 FCC Part 15 Subpart E & RSS-210 Client Device Test Result Summary	10
Table 2 FCC Part 15 Subpart E & RSS-210 Client Device Test Result Summary	11
Table 3 Summary of All Results for 10 MHz Bandwidth	25
Table 4 FCC & RSS-210 Short Pulse Radar (Type 1) Test Results	26
Table 5 FCC & RS-210 Short Pulse Radar (Type 2) Test Results	28
Table 6 FCC & RSS-210 Short Pulse Radar (Type 3) Test Results	29
Table 7 FCC & RSS-210 Short Pulse Radar (Type 4) Test Results	31
Table 8 FCC& RSS-210 frequency hopping radar (Type 6) Test Results	48
Table 9 Long Sequence Waveform Summary	49
Table 10 Long Sequence Waveform Trial#1 (Detected)	50
Table 11 Long Sequence Waveform Trial#2 (Detected)	50
Table 12 Long Sequence Waveform Trial#3 (Detected)	51
Table 13 Long Sequence Waveform Trial#4 (Detected)	51
Table 14 Long Sequence Waveform Trial#5 (Detected)	52
Table 15 Long Sequence Waveform Trial#6 (Detected)	53
Table 16 Long Sequence Waveform Trial#7 (Detected)	53
Table 17 Long Sequence Waveform Trial#8 (Detected)	54
Table 18 Long Sequence Waveform Trial#9 (Detected)	54
Table 19 Long Sequence Waveform Trial#10 (Detected)	55
Table 20 Long Sequence Waveform Trial#11 (Detected)	55
Table 21 Long Sequence Waveform Trial#12 (Detected)	56
Table 22 Long Sequence Waveform Trial#13 (Detected)	57
Table 23 Long Sequence Waveform Trial#14 (Detected)	57
Table 24 Long Sequence Waveform Trial#15 (Detected)	58
Table 25 Long Sequence Waveform Trial#16 (Detected)	58
Table 26 Long Sequence Waveform Trial#17 (Detected)	59
Table 27 Long Sequence Waveform Trial#18 (Detected)	59
Table 28 Long Sequence Waveform Trial#19 (Detected)	59
Table 29 Long Sequence Waveform Trial#20 (Detected)	60
Table 30 Long Sequence Waveform Trial#21 (Detected)	60
Table 31 Long Sequence Waveform Trial#22 (Detected)	61
Table 32 Long Sequence Waveform Trial#23 (Detected)	61
Table 33 Long Sequence Waveform Trial#24 (Detected)	62
Table 34 Long Sequence Waveform Trial#25 (Detected)	62
Table 35 Long Sequence Waveform Trial#26 (Detected)	63
Table 36 Long Sequence Waveform Trial#27 (Detected)	63
Table 37 Long Sequence Waveform Trial#28 (Detected)	64
Table 38 Long Sequence Waveform Trial#29 (Detected)	64
Table 39 Long Sequence Waveform Trial#30 (Detected)	65
Table 40 Summary of All Results for 20 MHz Bandwidth	66

Table 41 FCC Short Pulse Radar (Type 1) Test Results.....	67
Table 42 FCC Short Pulse Radar (Type 2) Test Results.....	69
Table 43 FCC Short Pulse Radar (Type 3) Test Results.....	70
Table 44 FCC Short Pulse Radar (Type 4) Test Results.....	71
Table 45 Long Sequence Waveform Summary	73
Table 46 Long Sequence Waveform Trial#1 (Detected)	73
Table 47 Long Sequence Waveform Trial#2 (Detected)	74
Table 48 Long Sequence Waveform Trial#3 (Detected)	74
Table 49 Long Sequence Waveform Trial#4 (Detected)	75
Table 50 Long Sequence Waveform Trial#5 (Detected)	76
Table 51 Long Sequence Waveform Trial#6 (Detected)	76
Table 52 Long Sequence Waveform Trial#7 (Detected)	77
Table 53 Long Sequence Waveform Trial#8 (Detected)	77
Table 54 Long Sequence Waveform Trial#9 (Detected)	78
Table 55 Long Sequence Waveform Trial#10 (Detected)	78
Table 56 Long Sequence Waveform Trial#11 (Detected)	79
Table 57 Long Sequence Waveform Trial#12 (Detected)	79
Table 58 Long Sequence Waveform Trial#13 (Detected)	80
Table 59 Long Sequence Waveform Trial#14 (Detected)	80
Table 60 Long Sequence Waveform Trial#15 (** NOT Detected **).....	80
Table 61 Long Sequence Waveform Trial#16 (Detected)	81
Table 62 Long Sequence Waveform Trial#17 (Detected)	81
Table 63 Long Sequence Waveform Trial#18 (Detected)	82
Table 64 Long Sequence Waveform Trial#19 (Detected)	82
Table 65 Long Sequence Waveform Trial#20 (Detected)	83
Table 66 Long Sequence Waveform Trial#21 (Detected)	83
Table 67 Long Sequence Waveform Trial#22 (Detected)	84
Table 68 Long Sequence Waveform Trial#23 (Detected)	84
Table 69 Long Sequence Waveform Trial#24 (Detected)	85
Table 70 Long Sequence Waveform Trial#25 (** NOT Detected **).....	85
Table 71 Long Sequence Waveform Trial#26 (Detected)	85
Table 72 Long Sequence Waveform Trial#27 (Detected)	86
Table 73 Long Sequence Waveform Trial#28 (Detected)	86
Table 74 Long Sequence Waveform Trial#29 (Detected)	87
Table 75 Long Sequence Waveform Trial#30 (Detected)	87
Table 76 FCC frequency hopping radar (Type 6) Test Results	101
Table 77 Summary of All Results for 40 MHz Bandwidth	102
Table 78 FCC Short Pulse Radar (Type 1) Test Results.....	103
Table 79 FCC Short Pulse Radar (Type 2) Test Results.....	105
Table 80 FCC Short Pulse Radar (Type 3) Test Results.....	106
Table 81 FCC Short Pulse Radar (Type 4) Test Results.....	107
Table 82 FCC frequency hopping radar (Type 6) Test Results	113
Table 83 Long Sequence Waveform Summary	115
Table 84 Long Sequence Waveform Trial#1 (Detected)	115
Table 85 Long Sequence Waveform Trial#2 (** NOT Detected **).....	116
Table 86 Long Sequence Waveform Trial#3 (Detected)	116
Table 87 Long Sequence Waveform Trial#4 (Detected)	117
Table 88 Long Sequence Waveform Trial#5 (Detected)	117
Table 89 Long Sequence Waveform Trial#6 (Detected)	118

Table 90 Long Sequence Waveform Trial#7 (Detected)	119
Table 91 Long Sequence Waveform Trial#8 (Detected)	120
Table 92 Long Sequence Waveform Trial#9 (Detected)	120
Table 93 Long Sequence Waveform Trial#10 (Detected)	121
Table 94 Long Sequence Waveform Trial#11 (Detected)	121
Table 95 Long Sequence Waveform Trial#12 (Detected)	122
Table 96 Long Sequence Waveform Trial#13 (Detected)	122
Table 97 Long Sequence Waveform Trial#14 (Detected)	122
Table 98 Long Sequence Waveform Trial#15 (Detected)	123
Table 99 Long Sequence Waveform Trial#16 (Detected)	123
Table 100 Long Sequence Waveform Trial#17 (Detected)	124
Table 101 Long Sequence Waveform Trial#18 (Detected)	124
Table 102 Long Sequence Waveform Trial#19 (Detected)	125
Table 103 Long Sequence Waveform Trial#20 (Detected)	125
Table 104 Long Sequence Waveform Trial#21 (Detected)	125
Table 105 Long Sequence Waveform Trial#22 (Detected)	126
Table 106 Long Sequence Waveform Trial#23 (Detected)	127
Table 107 Long Sequence Waveform Trial#24 (Detected)	127
Table 108 Long Sequence Waveform Trial#25 (Detected)	128
Table 109 Long Sequence Waveform Trial#26 (Detected)	128
Table 110 Long Sequence Waveform Trial#27 (Detected)	129
Table 111 Long Sequence Waveform Trial#28 (Detected)	129
Table 112 Long Sequence Waveform Trial#29 (Detected)	130
Table 113 Long Sequence Waveform Trial#30 (Detected)	130
Table 114 FCC Part 15 Subpart E Channel Closing Test Results for 10 MHz Bandwidth.....	131
Table 115 FCC Part 15 Subpart E Channel Closing Test Results for 20 MHz Bandwidth.....	134
Table 116 FCC Part 15 Subpart E Channel Closing Test Results for 40 MHz Bandwidth.....	137
Figure 1 Test Configuration for radiated Measurement Method	16
Figure 2 Channel Utilization During In-Service Detection Measurements	24
Figure 3 Expected Loading For a 19 Channel System (1,000 Trials).....	149
Figure 4 Expected Loading For a 9 Channel System (1,000 Trials).....	149
Figure 5 Expected Loading For a 11 Channel System (1,000 Trials).....	150
Figure 6 Expected Loading For a 19 Channel System (10,000 Trials).....	151
Figure 7 Expected Loading For a 9 Channel System (10,000 Trials).....	151
Figure 8 Expected Loading For a 11 Channel System (10,000 Trials).....	152

SCOPE

The Federal Communications Commission, Industry Canada, and the European Telecommunications Standards Institute (ETSI) publish standards regarding ElectroMagnetic Compatibility and Radio spectrum Matters for radio-communications devices. Tests have been performed on the Redline Communications, Inc. model AN-80i in accordance with these standards.

Test data has been taken pursuant to the relevant requirements of the following standard(s):

- FCC Part 15.407 Subpart E Unlicensed National Information Infrastructure (U-NII) Devices
- RSS-210, Issue 6 (Low-power License-exempt Radiocommunication Devices)

Tests were performed in accordance with these standards together with the current published versions of the basic standards referenced therein as outlined in Elliott Laboratories test procedures.

The test results recorded herein are based on a single type test of the Redline Communications, Inc. model AN-80i and therefore apply only to the tested sample. The sample was selected and prepared by Medhat Fawzy of Redline Communications, Inc..

OBJECTIVE

The objective of the manufacturer is to comply with the standards identified in the previous section. In order to demonstrate compliance, the manufacturer or a contracted laboratory makes measurements and takes the necessary steps to ensure that the equipment complies with the appropriate technical standards. Compliance with some DFS features are covered through a manufacturer statement or through observation of the device.

STATEMENT OF COMPLIANCE

The tested sample of Redline Communications, Inc. model AN-80i complied with the DFS requirements of:

FCC Part 15.407
RSS-210, Issue 6

Maintenance of compliance is the responsibility of the manufacturer. Any modifications to the product should be assessed to determine their potential impact on the compliance status of the device with respect to the standards detailed in this test report.

DEVIATIONS FROM THE STANDARD

No deviations were made from the test methods and requirements covered by the scope of this report.

EQUIPMENT UNDER TEST (EUT) DETAILS**GENERAL**

The Redline Communications, Inc. model AN-80i is a non-preparatory wireless broadband used to deliver high speed Internet and networking to industries.

The sample was received on November 1, 2006 and tested on November 1, 2006. The EUT consisted of the following component(s):

Manufacturer	Model	Description	Serial Number
Redline Communications, Inc.	AN-80i	Advance Broadband Wireless Transport Device	N/A

The manufacturer declared values for the EUT operational characteristics that affect DFS are as follows:

Operating Modes

- Master Device
 Client Device
 Client Device with In-Service Monitoring

Antenna Gains / EIRP

	5470 – 5725 MHz
Lowest Antenna Gain (dBi)	22
Highest Antenna Gain (dBi)	28
Output Power (dBm)	9.5

- Power can exceed 200mW eirp

Channel Protocol

- IP Based
 Frame Based
 OTHER _____

ENCLOSURE

The EUT enclosure measures approximately 25cm W by 15cm D by 5cm H. It is primarily constructed of aluminum.

MODIFICATIONS

The EUT required the following modifications in order to comply with the requirements of the standard(s) referenced in this test report.

Radar sensitivity threshold was modified to allow detecting of radar during CAC test.

SUPPORT EQUIPMENT

The following equipment was used as local support equipment for testing:

Manufacturer	Model	Description	Serial Number	FCC ID
MTI Wireless Edge LTD.	48-00021-02	20dBi antenna	01040	N/A
<i>Redline</i>	<i>AN-80i</i>	<i>Master Device</i>	N/A	<i>Applicant to provide</i>

The italicized device was the master device.

EUT INTERFACE PORTS

The I/O cabling configuration during testing was as follows:

Port	Connected To	Cable(s)		
		Description	Shielded or Unshielded	Length(m)
RF	22 dBi antenna	Coaxial	Shielded	.5
Ethernet	Laptop	Cat5	Unshielded	15

EUT OPERATION

The EUT was operating with the following software.

Client Device: RL80_F_0110_159

The manufacturer provided special software that over-rode the non-occupancy mechanism (allowing return to the same channel) for the purposes of determining the probability of detection. This test feature was disabled and the normal operating software enabled for verifying the 30-minute non-occupancy period and channel move time.

The start of the Channel Availability Check was the instant the command to change channel was sent.

During the in-service monitoring detection probability and channel moving tests the system was configured with a streaming video file from the master device (sourced by the PC connected to the master device via an ethernet interface) to the client device.

The streamed file was the "FCC" test file and the client device was using Windows Media Player Classic as required by FCC Part 15 Subpart E

The channel loading was evaluated to be 65.6%. Refer to Page 17 for channel loading plot.

TEST RESULTS**TEST RESULTS SUMMARY – FCC Part 15 & RSS-210, CLIENT DEVICE (10 MHz)**

Description	Radar Type	Radar Frequency	Measured Value	Requirement	Test Data	Status
Channel Availability Check (CAC) Time	Type 1	5530 MHz	> 60s	≥ 60s	Appendix D	Pass
CAC Detection Threshold	Type 1	5530 MHz	-64dBm	-64dBm (see note 2)	Appendix D	Pass
In-Service Monitoring Detection Threshold	Type 1 Type 2 Type 3 Type 4 Type 5 Type 6	5530 MHz	-64 dBm -64 dBm -64 dBm -64 dBm -64 dBm -64 dBm	-64dBm (see note 2)	Appendix C	Pass
Channel closing transmission time	Type 1 Type 5	5530 MHz	37.1ms 0ms	≤ 60ms	Appendix C	Pass
Channel move time	Type 1 Type 5	5530 MHz	.464s 0s	≤ 10s	Appendix C	Pass
Non-occupancy period	N/A	5530 MHz	> 30 mins	> 30 minutes	Appendix C	Pass
5600 – 5650 MHz CAC or In-service monitoring Radar detection	Type 1 or Type 5	5530 MHz	10 mins continuous monitoring	10 minutes	Note 2	Pass
UNII Detection Bandwidth	Type 1	5530 MHz	10MHz = 18MHz	Minimum 80% of the UNII 99% transmission power bandwidth.	Appendix E	Pass
Uniform Loading		-	-	Uniform Loading	Refer to operational description	Information provided by client
Transmit Power Control		<p>A) First one, is automatically enabled when DFS is enable and its purpose is to keep the transmit power at a level which generate an RSSI on the receiver side below the radar power threshold which have to be detected.</p> <p>B) The second one could be enabled or disabled by the user and it keeps the transmit power at the lowest level which give the best SNR on the receiver side.</p>				Information provided by client

Table 1 FCC Part 15 Subpart E & RSS-210 Client Device Test Result Summary

Notes:

- 1) During the 10 minute monitoring no transmission was detected.

TEST RESULTS SUMMARY – FCC Part 15 & RSS-210, CLIENT DEVICE (20 MHz)

Description	Radar Type	Radar Frequency	Measured Value	Requirement	Test Data	Status
Channel Availability Check (CAC) Time	Type 1	5530 MHz	> 60s	≥ 60s	Appendix D	Pass
CAC Detection Threshold	Type 1	5530 MHz	-64dBm	-64dBm (see note 2)	Appendix D	Pass
In-Service Monitoring Detection Threshold	Type 1 Type 2 Type 3 Type 4 Type 5 Type 6	5530 MHz	-64 dBm -64 dBm -64 dBm -64 dBm -64 dBm -64 dBm	-64dBm (see note 2)	Appendix C	Pass
Channel closing transmission time	Type 1 Type 5	5530 MHz	2 ms 0 ms	≤ 60ms	Appendix C	Pass
Channel move time	Type 1 Type 5	5530 MHz	.498 s 0 s	≤ 10s	Appendix C	Pass
Non-occupancy period	N/A	5530 MHz	> 30 mins	> 30 minutes	Appendix C	Pass
5600 – 5650 MHz CAC or In-service monitoring Radar detection	Type 1 or Type 5	5530 MHz	10 mins continuous monitoring	10 minutes	Note 2	Pass
UNII Detection Bandwidth	Type 1	5530 MHz	20MHz = 19MHz	Minimum 80% of the UNII 99% transmission power bandwidth.	Appendix E	Pass
Uniform Loading		-	-	Uniform Loading	Refer to operational description	Information provided by client
Transmit Power Control		<p>C) First one, is automatically enabled when DFS is enable and its purpose is to keep the transmit power at a level which generate an RSSI on the receiver side below the radar power threshold which have to be detected.</p> <p>D) The second one could be enabled or disabled by the user and it keeps the transmit power at the lowest level which give the best SNR on the receiver side.</p>				Information provided by client

Table 2 FCC Part 15 Subpart E & RSS-210 Client Device Test Result Summary

Notes:

- 1) During the 10 minute monitoring no transmission was detected.

TEST RESULTS SUMMARY – FCC Part 15 & RSS-210, CLIENT DEVICE (40 MHz)

Description	Radar Type	Radar Frequency	Measured Value	Requirement	Test Data	Status
Channel Availability Check (CAC) Time	Type 1	5530 MHz	> 60s	≥ 60s	Appendix D	Pass
CAC Detection Threshold	Type 1	5530 MHz	-64dBm	-64dBm (see note 2)	Appendix D	Pass
In-Service Monitoring Detection Threshold	Type 1 Type 2 Type 3 Type 4 Type 5 Type 6	5530 MHz	-64 dBm -64 dBm -64 dBm -64 dBm -64 dBm -64 dBm	-64dBm (see note 2)	Appendix C	Pass
Channel closing transmission time	Type 1 Type 5	5530 MHz	0 ms 0 ms	≤ 60ms	Appendix C	Pass
Channel move time	Type 1 Type 5	5530 MHz	.4 s .8 s	≤ 10s	Appendix C	Pass
Non-occupancy period	N/A	5530 MHz	> 30 mins	> 30 minutes	Appendix C	Pass
5600 – 5650 MHz CAC or In-service monitoring Radar detection	Type 1 or Type 5	5530 MHz	10 mins continuous monitoring	10 minutes	Note 2	Pass
UNII Detection Bandwidth	Type 1	5530 MHz	40MHz = 38MHz	Minimum 80% of the UNII 99% transmission power bandwidth.	Appendix E	Pass
Uniform Loading		-	-	Uniform Loading	Refer to operational description	Information provided by client
Transmit Power Control		<p>E) First one, is automatically enabled when DFS is enable and its purpose is to keep the transmit power at a level which generate an RSSI on the receiver side below the radar power threshold which have to be detected.</p> <p>F) The second one could be enabled or disabled by the user and it keeps the transmit power at the lowest level which give the best SNR on the receiver side.</p>				Information provided by client

Table 3 FCC Part 15 Subpart E & RSS-210 Client Device Test Result Summary

Notes:

- 1) During the 10 minute monitoring no transmission was detected.

MEASUREMENT UNCERTAINTIES

ISO / IEC 17025 requires that an estimate of the uncertainties associated with the measurement(s) be included in the report for applicable standards. The measurement uncertainties given below are based on a 95% confidence level, with a coverage factor (k=2) and were calculated in accordance with the ISO Guide to the Expression of Uncertainty in Measurement.

Measurement	Measurement Unit	Expanded Uncertainty
Timing (Channel move time, aggregate transmission time)	ms	Timing resolution +/-
Timing (non occupancy period)	seconds	5 seconds
DFS Threshold (radiated)	dBm	
DFS Threshold (conducted)	dBm	

DFS TEST METHODS**RADIATED TEST METHOD**

The combination of master and slave devices is located in an anechoic chamber. The simulated radar waveform is transmitted from a directional horn antenna (typically an EMCO 3115) toward the unit performing the radar detection (radar detection device, RDD). Every effort is made to ensure that the main beam of the EUT's antenna is aligned with the radar generating antenna.

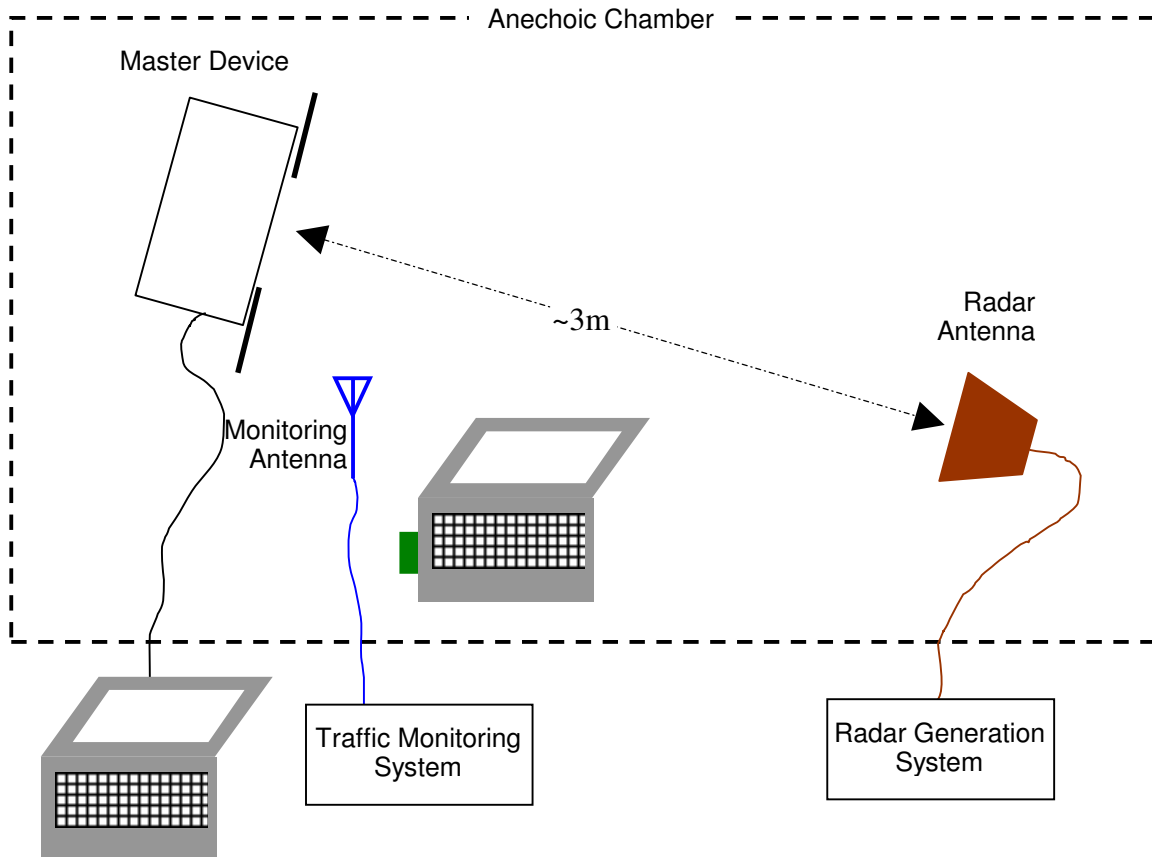

Figure 1 Test Configuration for radiated Measurement Method

The signal level of the simulated waveform is set to a reference level equal to the threshold level (plus 1dB if testing against FCC requirements). Lower levels may also be applied on request of the manufacturer. The level reported is the level at the RDD antenna and so it is not corrected for the RDD's antenna gain. The RDD is configured with the lowest gain antenna assembly intended for use with the device.

The signal level is verified by measuring the CW signal level from the radar generation system using a reference antenna of gain G (dBi). The radar signal level is calculated from the measured level, R (dBm), and any cable loss, L (dB), between the reference antenna and the measuring instrument:

$$\text{Applied level (dBm)} = R - G_{REF} + L$$

If both master and client devices have radar detection capability then the device not under test is positioned with absorbing material between its antenna and the radar generating antenna, and the radar level at the non RDD is verified to be at least 20dB below the threshold level to ensure that any responses are due to the RDD detecting radar.

The antenna connected to the channel monitoring subsystem is positioned to allow both master and client transmissions to be observed, with the level of the EUT's transmissions between 6 and 10dB higher than those from the other device.

DFS MEASUREMENT INSTRUMENTATION

RADAR GENERATION SYSTEM

An Agilent PSG is used as the radar-generating source. The integral arbitrary waveform generators are programmed using Agilent's "Pulse Building" software and Elliott custom software to produce the required waveforms, with the capability to produce both unmodulated and modulated (FM Chirp) pulses. Where there are multiple values for a specific radar parameter then the software selects a value at random and, for FCC tests, the software verifies that the resulting waveform is truly unique.

With the exception of the hopping waveforms required by the FCC's rules (see below), the radar generator is set to a single frequency within the radar detection bandwidth of the EUT.

Frequency hopping radar waveforms are simulated using a time domain model. A randomly hopping sequence algorithm (which uses each channel in the hopping radar's range once in a hopping sequence) generates a hop sequence. A segment of the first 100 elements of the hop sequence are then examined to determine if it contains one or more frequencies within the radar detection bandwidth of the EUT. If it does not then the first element of the segment is discarded and the next frequency in the sequence is added. The process repeats until a valid segment is produced. The radar system is then programmed to produce bursts at time slots coincident with the frequencies within the segment that fall in the detection bandwidth. The frequency of the generator is stepped in 1 MHz increments across the EUT's detection range.

The radar signal level is verified during testing using a CW signal with the AGC function switched on. Correction factors to account for the fact that pulses are generated with the AGC functions switched off are measured annually and an offset is used to account for this in the software.

The generator output is connected to the coupling port of the conducted set-up or to the radar generating antenna.

CHANNEL MONITORING SYSTEM

Channel monitoring is achieved using a spectrum analyzer and digital storage oscilloscope. The analyzer is configured in a zero-span mode, center frequency set to the radar waveform's frequency or the center frequency of the EUT's operating channel. The IF output of the analyzer is connected to one input of the oscilloscope.

A signal generator output is set to send either the modulating signal directly or a pulse gate with an output pulse co-incident with each radar pulse. This output is connected to a second input on the oscilloscope and the oscilloscope displays both the channel traffic (via the if input) and the radar pulses on its display.

For in service monitoring tests the analyzer sweep time is set to > 20 seconds and the oscilloscope is configured with a data record length of 10 seconds for the short duration and frequency hopping waveforms, 20 seconds for the long duration waveforms. Both instruments are set for a single acquisition sequence. The analyzer is triggered 500ms

before the start of the waveform and the oscilloscope is triggered directly by the modulating pulse train. Timing measurements for aggregate channel transmission time and channel move time are made from the oscilloscope data, with the end of the waveform clearly identified by the pulse train on one trace. The analyzer trace data is used to confirm that the last transmission occurred within the 10 second record of the oscilloscope. If necessary the record length of the oscilloscope is expanded to capture the last transmission on the channel prior to the channel move.

Channel availability check time timing plots are made using the analyzer. The analyzer is triggered at start of the EUT's channel availability check and used to verify that the EUT does not transmit when radar is applied during the check time.

The analyzer detector and oscilloscope sampling mode is set to peak detect for all plots.

DFS MEASUREMENT METHODS

DFS RADAR DETECTION BANDWIDTH

The radar detection bandwidth is determined by using on of the radar waveforms (in the FCC case, the selection is limited to the short duration burst waveforms) and applying radar pulses at offset from the center channel frequency by multiples of 1MHz. These bursts are applied with no traffic on the channel. The first frequencies above and below the center channel frequency that have a detection rate below 90% define the radar bandwidth, the actual range being 1MHz below the upper frequency and 1MHz above the lower frequency.

DFS – CHANNEL CLOSING TRANSMISSION TIME AND CHANNEL MOVE TIME

Channel clearing and closing times are measured by applying a radar burst with the device configured to change channel and by observing the channel for transmissions. The time between the end of the applied radar waveform and the final transmission on the channel is the channel move time.

The aggregate transmission closing time is measured in two ways:

FCC & RSS-210 – the total time of all individual transmissions from the EUT that are observed starting 200ms at the end of the last radar pulse in the waveform. This value is required to be less than 60ms.

DFS CHANNEL AVAILABILITY CHECK TIME

It is preferred that the EUT report when it starts the radar channel availability check. In this case a single burst of one radar type is applied within 6 seconds of observing the start of the channel availability check and it is verified that the device does not use the channel. The test is repeated by applying a radar burst no sooner than 54 seconds and no later than 60 seconds after the start of the check.

If the EUT does not report the start of the check time, then the time to start transmitting on a channel after switching the device on is measured to approximate the time from power-on to the end of the channel availability check. The start of the channel availability check is assumed to be 60 seconds prior to the first transmission on the channel.

UNIFORM LOADING

Compliance with the channel loading requirement, where appropriate (i.e. when channel selection is not determined under control of the network), is demonstrated through the manufacturer's statement(s).

TRANSMIT POWER CONTROL (TPC)

Compliance with the transmit power control requirements for devices is demonstrated through measurements showing multiple power levels and manufacturer statements explaining how the power control is implemented.

SAMPLE CALCULATIONS

DETECTION PROBABILITY / SUCCESS RATE

The detection probability, or success rate, for any one radar waveform equals the number of successful trials divided by the total number of trials for that waveform.

In the case of the FCC requirements, for radar waveform types 1 through 4 an additional calculation is made to determine the average detection probability over all four radar waveform types. This calculation is the arithmetic mean of the four individual probabilities.

THRESHOLD LEVEL

The threshold level is the level of the simulated radar waveform at the EUT's antenna. If the test is performed in a conducted fashion then the level at the rf input equals the level at the antenna plus the gain of the antenna assembly, in dBi. The gain of the antenna assembly equals the gain of the antenna minus the loss of the cabling between the rf input and the antenna. The lowest gain value for all antenna assemblies intended for use with the device is used when making this calculation.

If the test is performed using the radiated method then the threshold level is the level at the antenna.

Appendix A Test Equipment Calibration Data

<u>Manufacturer</u>	<u>Description</u>	<u>Model #</u>	<u>Asset #</u>	<u>Cal Due</u>
Hewlett Packard	EMC Spectrum Analyzer, 9 kHz - 6.5 GHz	8595EM	787	10-Jan-07
EMCO	Antenna, Horn, 1-18 GHz (SA40, 30 Hz)	3115	1142	07-Jun-07
Tektronix	1 GHz Oscilloscope	TDS5104	1435	10-Apr-07
EMCO	Antenna, Horn, 1-18 GHz	3117	1662	07-Apr-07
Agilent	Vector Signal Generator (250kHz - 20GHz)	E8267C	1877	23-Nov-07

Appendix B Test Data Tables for Radar Detection Probability FCC & RSS-210

The plot below shows the channel loading during testing as evaluated over a 1 second period. The traffic was generated by MPEG File provided by FCC. Movie was played from master to client and from client to master to produce traffic greater then 40%.

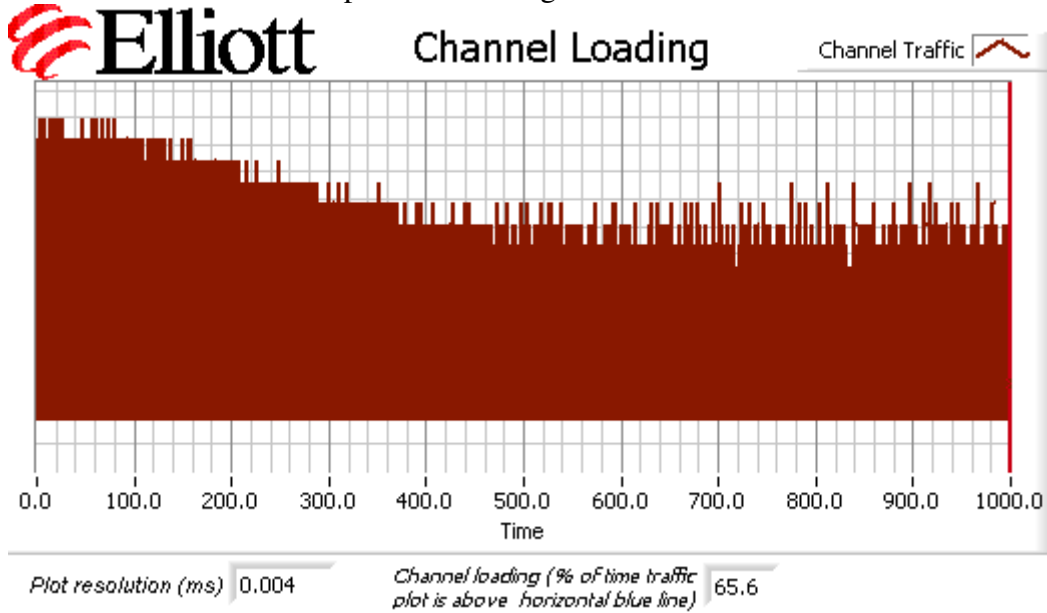

Figure 2 Channel Utilization During In-Service Detection Measurements

Waveform Name	Success Rate	Number of Trials
FCC & RSS-210 Short Pulse Radar (Type 1)	100.0 %	30
FCC & RSS-210 Short Pulse Radar (Type 2)	100 %	30
FCC & RSS-210 Short Pulse Radar (Type 3)	100.0 %	30
FCC & RSS-210 Short Pulse Radar (Type 4)	93.3 %	30
FCC & RSS-210 frequency hopping radar (Type 6)	100.0 %	30
Long Sequence	100.0 %	30

Table 3 Summary of All Results for 10 MHz Bandwidth

Trial #	Pulses/Burst	Pulse Width (us)	PRI (us)	Detected ?	Fr (MHz) and level (dBm)	Hop seq.
0	18	1.0	1428.0	Yes	5530.0MHz, -64.0dBm	N/A
1	18	1.0	1428.0	Yes	5530.0MHz, -64.0dBm	N/A
2	18	1.0	1428.0	Yes	5530.0MHz, -64.0dBm	N/A
3	18	1.0	1428.0	Yes	5530.0MHz, -64.0dBm	N/A
4	18	1.0	1428.0	Yes	5530.0MHz, -64.0dBm	N/A
5	18	1.0	1428.0	Yes	5530.0MHz, -64.0dBm	N/A
6	18	1.0	1428.0	Yes	5530.0MHz, -64.0dBm	N/A
7	18	1.0	1428.0	Yes	5530.0MHz, -64.0dBm	N/A
8	18	1.0	1428.0	Yes	5530.0MHz, -64.0dBm	N/A
9	18	1.0	1428.0	Yes	5530.0MHz, -64.0dBm	N/A
10	18	1.0	1428.0	Yes	5530.0MHz, -64.0dBm	N/A
11	18	1.0	1428.0	Yes	5530.0MHz, -64.0dBm	N/A
12	18	1.0	1428.0	Yes	5530.0MHz, -64.0dBm	N/A

13	18	1.0	1428.0	Yes	5530.0MHz, -64.0dBm	N/A
14	18	1.0	1428.0	Yes	5530.0MHz, -64.0dBm	N/A
15	18	1.0	1428.0	Yes	5530.0MHz, -64.0dBm	N/A
16	18	1.0	1428.0	Yes	5530.0MHz, -64.0dBm	N/A
17	18	1.0	1428.0	Yes	5530.0MHz, -64.0dBm	N/A
18	18	1.0	1428.0	Yes	5530.0MHz, -64.0dBm	N/A
19	18	1.0	1428.0	Yes	5530.0MHz, -64.0dBm	N/A
20	18	1.0	1428.0	Yes	5530.0MHz, -64.0dBm	N/A
21	18	1.0	1428.0	Yes	5530.0MHz, -64.0dBm	N/A
22	18	1.0	1428.0	Yes	5530.0MHz, -64.0dBm	N/A
23	18	1.0	1428.0	Yes	5530.0MHz, -64.0dBm	N/A
24	18	1.0	1428.0	Yes	5530.0MHz, -64.0dBm	N/A
25	18	1.0	1428.0	Yes	5530.0MHz, -64.0dBm	N/A
26	18	1.0	1428.0	Yes	5530.0MHz, -64.0dBm	N/A
27	18	1.0	1428.0	Yes	5530.0MHz, -64.0dBm	N/A
28	18	1.0	1428.0	Yes	5530.0MHz, -64.0dBm	N/A
29	18	1.0	1428.0	Yes	5530.0MHz, -64.0dBm	N/A

Table 4 FCC & RSS-210 Short Pulse Radar (Type 1) Test Results

Trial #	Pulses/Burst	Pulse Width (us)	PRI (us)	Detected ?	Fr (MHz) and level (dBm)	Hop seq.
0	27	4.0	189.0	Yes	5530.0MHz, -64.0dBm	N/A
1	27	3.1	220.0	Yes	5530.0MHz, -64.0dBm	N/A
2	24	4.6	223.0	Yes	5530.0MHz, -64.0dBm	N/A
3	24	3.8	224.0	Yes	5530.0MHz, -64.0dBm	N/A
4	25	3.1	186.0	Yes	5530.0MHz, -64.0dBm	N/A
5	25	4.2	156.0	Yes	5530.0MHz, -64.0dBm	N/A
6	27	3.9	176.0	Yes	5530.0MHz, -64.0dBm	N/A
7	24	2.9	190.0	Yes	5530.0MHz, -64.0dBm	N/A
8	24	1.4	152.0	Yes	5530.0MHz, -64.0dBm	N/A
9	25	2.8	220.0	Yes	5530.0MHz, -64.0dBm	N/A
10	28	1.3	226.0	Yes	5530.0MHz, -64.0dBm	N/A
11	25	1.7	204.0	Yes	5530.0MHz, -64.0dBm	N/A
12	25	1.9	182.0	Yes	5530.0MHz, -64.0dBm	N/A
13	26	3.7	182.0	Yes	5530.0MHz, -64.0dBm	N/A
14	29	3.1	163.0	Yes	5530.0MHz, -64.0dBm	N/A
15	27	3.3	170.0	Yes	5530.0MHz, -64.0dBm	N/A
16	23	3.5	195.0	Yes	5530.0MHz, -64.0dBm	N/A
17	23	2.0	226.0	Yes	5530.0MHz, -64.0dBm	N/A
18	26	1.3	217.0	Yes	5530.0MHz, -64.0dBm	N/A
19	28	1.2	213.0	Yes	5530.0MHz, -64.0dBm	N/A
20	26	5.0	208.0	Yes	5530.0MHz, -64.0dBm	N/A
21	29	2.6	151.0	Yes	5530.0MHz, -64.0dBm	N/A

22	25	2.2	156.0	Yes	5530.0MHz, -64.0dBm	N/A
23	25	2.8	165.0	Yes	5530.0MHz, -64.0dBm	N/A
24	26	1.8	202.0	Yes	5530.0MHz, -64.0dBm	N/A
25	25	4.2	209.0	Yes	5530.0MHz, -64.0dBm	N/A
26	24	2.6	197.0	Yes	5530.0MHz, -64.0dBm	N/A
27	24	3.1	183.0	Yes	5530.0MHz, -64.0dBm	N/A
28	25	3.2	215.0	Yes	5530.0MHz, -64.0dBm	N/A
29	28	3.5	167.0	Yes	5530.0MHz, -64.0dBm	N/A

Table 5 FCC & RS-210 Short Pulse Radar (Type 2) Test Results

Trial #	Pulses/Burst	Pulse Width (us)	PRI (us)	Detected ?	Fr (MHz) and level (dBm)	Hop seq.
0	17	9.1	418.0	Yes	5530.0MHz, -64.0dBm	N/A
1	16	7.8	372.0	Yes	5530.0MHz, -64.0dBm	N/A
2	18	6.2	216.0	Yes	5530.0MHz, -64.0dBm	N/A
3	17	6.0	301.0	Yes	5530.0MHz, -64.0dBm	N/A
4	18	6.2	231.0	Yes	5530.0MHz, -64.0dBm	N/A
5	18	8.6	330.0	Yes	5530.0MHz, -64.0dBm	N/A
6	17	8.4	459.0	Yes	5530.0MHz, -64.0dBm	N/A
7	18	7.1	414.0	Yes	5530.0MHz, -64.0dBm	N/A
8	16	9.6	458.0	Yes	5530.0MHz, -64.0dBm	N/A
9	17	6.3	232.0	Yes	5530.0MHz, -64.0dBm	N/A
10	16	9.9	445.0	Yes	5530.0MHz, -64.0dBm	N/A
11	16	6.8	398.0	Yes	5530.0MHz, -64.0dBm	N/A
12	18	10.0	253.0	Yes	5530.0MHz, -64.0dBm	N/A

					-64.0dBm	
13	16	9.9	317.0	Yes	5530.0MHz, -64.0dBm	N/A
14	16	9.0	487.0	Yes	5530.0MHz, -64.0dBm	N/A
15	17	7.5	483.0	Yes	5530.0MHz, -64.0dBm	N/A
16	18	7.7	372.0	Yes	5530.0MHz, -64.0dBm	N/A
17	18	6.3	488.0	Yes	5530.0MHz, -64.0dBm	N/A
18	18	6.3	386.0	Yes	5530.0MHz, -64.0dBm	N/A
19	18	8.2	280.0	Yes	5530.0MHz, -64.0dBm	N/A
20	18	8.7	294.0	Yes	5530.0MHz, -64.0dBm	N/A
21	17	7.9	359.0	Yes	5530.0MHz, -64.0dBm	N/A
22	18	9.7	404.0	Yes	5530.0MHz, -64.0dBm	N/A
23	17	6.6	354.0	Yes	5530.0MHz, -64.0dBm	N/A
24	17	8.2	490.0	Yes	5530.0MHz, -64.0dBm	N/A
25	16	6.3	377.0	Yes	5530.0MHz, -64.0dBm	N/A
26	17	8.8	278.0	Yes	5530.0MHz, -64.0dBm	N/A
27	17	6.8	423.0	Yes	5530.0MHz, -64.0dBm	N/A
28	17	7.6	482.0	Yes	5530.0MHz, -64.0dBm	N/A
29	16	6.3	215.0	Yes	5530.0MHz, -64.0dBm	N/A

Table 6 FCC & RSS-210 Short Pulse Radar (Type 3) Test Results

Trial #	Pulses/Burst	Pulse Width (us)	PRI (us)	Detected ?	Fr (MHz) and level (dBm)	Hop seq.
0	13	19.8	485.0	Yes	5530.0MHz, -64.0dBm	N/A
1	16	11.6	305.0	Yes	5530.0MHz, -64.0dBm	N/A
2	14	13.5	334.0	Yes	5530.0MHz, -64.0dBm	N/A
3	13	16.4	471.0	Yes	5530.0MHz, -64.0dBm	N/A
4	14	19.6	239.0	Yes	5530.0MHz, -64.0dBm	N/A
5	13	17.3	499.0	Yes	5530.0MHz, -64.0dBm	N/A
6	14	13.6	295.0	Yes	5530.0MHz, -64.0dBm	N/A
7	16	12.8	433.0	Yes	5530.0MHz, -64.0dBm	N/A
8	15	15.0	445.0	No	5530.0MHz, -64.0dBm	N/A
9	16	12.6	380.0	Yes	5530.0MHz, -64.0dBm	N/A
10	15	16.9	265.0	Yes	5530.0MHz, -64.0dBm	N/A
11	13	16.5	474.0	Yes	5530.0MHz, -64.0dBm	N/A
12	13	18.1	366.0	Yes	5530.0MHz, -64.0dBm	N/A
13	15	16.1	432.0	Yes	5530.0MHz, -64.0dBm	N/A
14	13	15.7	370.0	Yes	5530.0MHz, -64.0dBm	N/A
15	14	16.2	437.0	Yes	5530.0MHz, -64.0dBm	N/A
16	14	16.9	491.0	Yes	5530.0MHz, -64.0dBm	N/A
17	16	19.8	479.0	Yes	5530.0MHz, -64.0dBm	N/A
18	16	19.6	309.0	Yes	5530.0MHz, -64.0dBm	N/A
19	13	17.8	408.0	Yes	5530.0MHz, -64.0dBm	N/A
20	14	19.3	201.0	Yes	5530.0MHz, -64.0dBm	N/A
21	15	13.0	278.0	Yes	5530.0MHz, -64.0dBm	N/A

22	15	13.2	464.0	Yes	5530.0MHz, -64.0dBm	N/A
23	13	15.1	287.0	No	5530.0MHz, -64.0dBm	N/A
24	16	13.3	416.0	Yes	5530.0MHz, -64.0dBm	N/A
25	14	17.5	365.0	Yes	5530.0MHz, -64.0dBm	N/A
26	12	13.1	436.0	Yes	5530.0MHz, -64.0dBm	N/A
27	12	15.4	320.0	Yes	5530.0MHz, -64.0dBm	N/A
28	15	12.8	224.0	Yes	5530.0MHz, -64.0dBm	N/A
29	14	15.9	409.0	Yes	5530.0MHz, -64.0dBm	N/A

Table 7 FCC & RSS-210 Short Pulse Radar (Type 4) Test Results

Trial #	Pulses/Burst	Pulse Width (us)	PRI (us)	Detected ?	Fr (MHz) and level (dBm)	Hop seq.
0	9	1.0	333.0	Yes	5515.0MHz, -64.0dBm	5612, 5581, 5301, 5299, 5404, 5371, 5702, 5596, 5338, 5689, 5416, 5642, 5510, 5323, 5615, 5594, 5525, 5531, 5655, 5670, 5588, 5609, 5646, 5698, 5592, 5506, 5313, 5361, 5530, 5401, 5528, 5314, 5421, 5605, 5641, 5267, 5629, 5669, 5552, 5515, 5548, 5422, 5678, 5558, 5322, 5723, 5277, 5725, 5395, 5651, 5630, 5724, 5579, 5259, 5534, 5345, 5389, 5697, 5687, 5295, 5403, 5487, 5679, 5306, 5681, 5497, 5483, 5671, 5504, 5566, 5335, 5722, 5659, 5577, 5312, 5364, 5376, 5614, 5486, 5367, 5320, 5366, 5509, 5530, 5638, 5576, 5369, 5547, 5275, 5667, 5458, 5680, 5441, 5462, 5461, 5383, 5321, 5620, 5495, 5435 (4 hits)
1	9	1.0	333.0	Yes	5516.0MHz, -64.0dBm	5356, 5630, 5519, 5359, 5709, 5473, 5548, 5317, 5284, 5398, 5722, 5361, 5380, 5515, 5530, 5372, 5627, 5584, 5710, 5485, 5313, 5510, 5503, 5502, 5439, 5699, 5664, 5270, 5595, 5427, 5256, 5603, 5573, 5389, 5633, 5384, 5681, 5590, 5354, 5424, 5381, 5652, 5251, 5499, 5504, 5477, 5524, 5333, 5583, 5555, 5457, 5623, 5299, 5520, 5423, 5478, 5486, 5511, 5358, 5406, 5582, 5320, 5674, 5530, 5622, 5581, 5567, 5483, 5292, 5408, 5577, 5409, 5717, 5318, 5469, 5257, 5377, 5367,

						5667, 5275, 5419, 5585, 5541, 5536, 5446, 5438, 5551, 5713, 5695, 5465, 5302, 5565, 5545, 5670, 5625, 5470, 5568, 5420, 5642, 5688 (4 hits)
2	9	1.0	333.0	Yes	5517.0MHz, -64.0dBm	5371, 5288, 5413, 5594, 5407, 5373, 5549, 5475, 5562, 5519, 5293, 5406, 5700, 5640, 5695, 5470, 5677, 5254, 5321, 5546, 5678, 5583, 5404, 5345, 5538, 5429, 5480, 5687, 5306, 5636, 5433, 5419, 5360, 5440, 5505, 5535, 5573, 5266, 5466, 5460, 5680, 5597, 5616, 5489, 5666, 5638, 5672, 5408, 5279, 5595, 5530, 5682, 5364, 5491, 5399, 5284, 5511, 5391, 5361, 5379, 5423, 5675, 5585, 5624, 5639, 5574, 5490, 5499, 5350, 5318, 5567, 5365, 5520, 5676, 5494, 5304, 5586, 5607, 5389, 5551, 5554, 5536, 5325, 5705, 5457, 5688, 5453, 5559, 5368, 5486, 5656, 5621, 5501, 5587, 5552, 5620, 5299, 5709, 5580, 5434 (4 hits)
3	9	1.0	333.0	Yes	5518.0MHz, -64.0dBm	5530, 5593, 5532, 5477, 5460, 5250, 5258, 5633, 5483, 5365, 5566, 5608, 5371, 5339, 5435, 5370, 5641, 5305, 5397, 5252, 5270, 5539, 5529, 5416, 5645, 5350, 5552, 5432, 5594, 5358, 5721, 5456, 5623, 5693, 5696, 5347, 5691, 5399, 5599, 5303, 5421, 5610, 5547, 5530, 5502, 5507, 5411, 5449, 5414, 5417, 5366, 5499, 5431, 5341, 5698, 5720, 5560, 5492, 5494, 5694, 5294, 5561, 5254, 5363, 5337, 5458,

						5652, 5545, 5338, 5381, 5314, 5635, 5284, 5459, 5682, 5510, 5461, 5253, 5267, 5667, 5715, 5583, 5712, 5287, 5542, 5580, 5636, 5442, 5573, 5302, 5707, 5466, 5518, 5611, 5524, 5519, 5530, 5640, 5484, 5434 (4 hits)
4	9	1.0	333.0	Yes	5519.0MHz, -64.0dBm	5579, 5573, 5662, 5543, 5253, 5385, 5607, 5586, 5675, 5451, 5262, 5528, 5400, 5476, 5427, 5394, 5576, 5527, 5308, 5432, 5420, 5356, 5251, 5627, 5368, 5257, 5444, 5273, 5519, 5553, 5633, 5473, 5339, 5589, 5320, 5455, 5694, 5666, 5483, 5656, 5441, 5557, 5643, 5345, 5522, 5454, 5629, 5290, 5611, 5556, 5716, 5695, 5598, 5530, 5631, 5708, 5438, 5718, 5702, 5655, 5690, 5307, 5362, 5674, 5467, 5618, 5380, 5275, 5431, 5465, 5723, 5484, 5480, 5367, 5604, 5508, 5509, 5318, 5310, 5670, 5294, 5567, 5502, 5453, 5523, 5489, 5403, 5530, 5580, 5665, 5619, 5407, 5411, 5428, 5499, 5263, 5358, 5264, 5568, 5314 (4 hits)
5	9	1.0	333.0	Yes	5520.0MHz, -64.0dBm	5717, 5439, 5673, 5404, 5376, 5668, 5463, 5258, 5611, 5338, 5669, 5380, 5593, 5434, 5428, 5586, 5424, 5357, 5556, 5549, 5372, 5392, 5630, 5478, 5453, 5590, 5564, 5597, 5652, 5551, 5378, 5641, 5714, 5464, 5677, 5388, 5313, 5406, 5351, 5395, 5301, 5610, 5409, 5292, 5621, 5620, 5496, 5361, 5269, 5267, 5690, 5692, 5421, 5459,

						5354, 5374, 5638, 5497, 5261, 5514, 5724, 5487, 5320, 5350, 5475, 5522, 5592, 5627, 5636, 5704, 5365, 5303, 5413, 5466, 5511, 5323, 5349, 5517, 5716, 5494, 5465, 5545, 5254, 5568, 5628, 5680, 5306, 5263, 5337, 5632, 5700, 5468, 5694, 5571, 5671, 5387, 5550, 5283, 5540, 5667 (2 hits)
6	9	1.0	333.0	Yes	5521.0MHz, -64.0dBm	5602, 5428, 5683, 5333, 5578, 5368, 5677, 5495, 5507, 5344, 5469, 5697, 5348, 5448, 5435, 5575, 5617, 5381, 5430, 5460, 5372, 5649, 5499, 5530, 5361, 5450, 5515, 5512, 5429, 5588, 5477, 5377, 5642, 5596, 5703, 5629, 5724, 5472, 5543, 5350, 5374, 5690, 5544, 5679, 5432, 5625, 5367, 5488, 5505, 5293, 5319, 5336, 5681, 5462, 5592, 5704, 5604, 5437, 5399, 5523, 5628, 5323, 5454, 5565, 5527, 5654, 5514, 5540, 5420, 5483, 5254, 5550, 5610, 5547, 5378, 5691, 5262, 5363, 5551, 5373, 5534, 5287, 5422, 5669, 5315, 5715, 5311, 5554, 5289, 5467, 5486, 5618, 5511, 5536, 5347, 5627, 5491, 5653, 5464, 5459 (5 hits)
7	9	1.0	333.0	Yes	5522.0MHz, -64.0dBm	5513, 5432, 5720, 5422, 5663, 5474, 5591, 5511, 5534, 5662, 5583, 5490, 5607, 5459, 5669, 5486, 5625, 5427, 5689, 5272, 5278, 5404, 5378, 5349, 5376, 5276, 5568, 5633, 5544, 5642, 5576, 5389, 5256, 5537, 5566, 5412, 5680, 5597, 5533, 5647, 5600, 5467,

						5457, 5504, 5598, 5612, 5623, 5414, 5613, 5415, 5545, 5413, 5282, 5671, 5348, 5255, 5655, 5382, 5395, 5524, 5336, 5664, 5549, 5339, 5302, 5485, 5312, 5653, 5284, 5577, 5466, 5688, 5390, 5472, 5586, 5254, 5334, 5289, 5565, 5475, 5317, 5525, 5496, 5410, 5540, 5673, 5498, 5550, 5650, 5614, 5701, 5460, 5558, 5697, 5570, 5624, 5643, 5592, 5581, 5635 (6 hits)
8	9	1.0	333.0	Yes	5523.0MHz, -64.0dBm	5636, 5527, 5675, 5279, 5482, 5298, 5559, 5313, 5689, 5480, 5401, 5696, 5417, 5476, 5395, 5269, 5656, 5304, 5442, 5698, 5640, 5325, 5396, 5709, 5426, 5713, 5679, 5348, 5507, 5649, 5668, 5530, 5280, 5364, 5625, 5555, 5309, 5678, 5536, 5370, 5470, 5542, 5475, 5256, 5508, 5518, 5283, 5651, 5692, 5296, 5683, 5598, 5558, 5317, 5540, 5419, 5525, 5382, 5490, 5428, 5385, 5415, 5366, 5519, 5405, 5579, 5538, 5686, 5623, 5635, 5661, 5644, 5353, 5531, 5491, 5642, 5466, 5457, 5723, 5717, 5351, 5432, 5512, 5316, 5392, 5288, 5441, 5711, 5267, 5677, 5484, 5275, 5530, 5593, 5517, 5662, 5560, 5626, 5646, 5449 (6 hits)
9	9	1.0	333.0	Yes	5524.0MHz, -64.0dBm	5571, 5331, 5477, 5392, 5707, 5361, 5520, 5272, 5279, 5254, 5323, 5509, 5515, 5685, 5281, 5306, 5287, 5266, 5275, 5354, 5670, 5521, 5433, 5412, 5341, 5462, 5303, 5514, 5516, 5719,

						5467, 5697, 5703, 5601, 5414, 5276, 5549, 5634, 5373, 5570, 5377, 5544, 5469, 5393, 5357, 5259, 5258, 5457, 5387, 5391, 5314, 5700, 5528, 5493, 5594, 5271, 5668, 5369, 5627, 5518, 5569, 5657, 5653, 5659, 5324, 5664, 5626, 5311, 5274, 5262, 5280, 5687, 5519, 5678, 5716, 5288, 5463, 5381, 5506, 5682, 5497, 5290, 5413, 5292, 5550, 5380, 5399, 5640, 5597, 5268, 5402, 5660, 5428, 5681, 5715, 5607, 5282, 5560, 5443, 5273 (3 hits)
10	9	1.0	333.0	Yes	5525.0MHz, -64.0dBm	5637, 5397, 5408, 5592, 5442, 5689, 5445, 5328, 5593, 5298, 5299, 5517, 5497, 5621, 5542, 5409, 5555, 5288, 5719, 5403, 5390, 5258, 5462, 5583, 5518, 5269, 5704, 5323, 5362, 5705, 5717, 5470, 5450, 5410, 5467, 5417, 5510, 5401, 5556, 5515, 5455, 5574, 5581, 5387, 5532, 5334, 5709, 5567, 5432, 5706, 5419, 5553, 5686, 5675, 5606, 5349, 5342, 5571, 5274, 5529, 5488, 5380, 5560, 5712, 5348, 5640, 5371, 5543, 5485, 5579, 5438, 5495, 5638, 5448, 5597, 5649, 5607, 5405, 5350, 5282, 5394, 5344, 5491, 5463, 5393, 5302, 5683, 5502, 5521, 5696, 5524, 5694, 5319, 5624, 5399, 5608, 5582, 5716, 5656, 5439 (4 hits)
11	9	1.0	333.0	Yes	5526.0MHz, -64.0dBm	5652, 5549, 5568, 5516, 5590, 5723, 5340, 5611, 5330, 5367, 5625, 5696, 5645, 5499, 5550, 5492, 5390, 5663,

						5579, 5513, 5274, 5714, 5657, 5416, 5665, 5435, 5487, 5405, 5457, 5483, 5276, 5562, 5582, 5401, 5639, 5392, 5383, 5286, 5695, 5380, 5308, 5371, 5256, 5337, 5616, 5544, 5629, 5265, 5634, 5357, 5721, 5361, 5660, 5540, 5267, 5622, 5452, 5376, 5555, 5506, 5395, 5583, 5523, 5322, 5605, 5475, 5619, 5468, 5668, 5567, 5431, 5704, 5474, 5644, 5620, 5586, 5655, 5315, 5480, 5285, 5666, 5708, 5541, 5529, 5503, 5702, 5564, 5336, 5394, 5411, 5432, 5698, 5610, 5270, 5273, 5382, 5358, 5717, 5436, 5694 (3 hits)
12	9	1.0	333.0	Yes	5527.0MHz, -64.0dBm	5631, 5638, 5325, 5291, 5580, 5554, 5588, 5550, 5628, 5673, 5444, 5463, 5347, 5476, 5609, 5313, 5483, 5261, 5292, 5683, 5285, 5621, 5492, 5363, 5600, 5395, 5352, 5255, 5374, 5584, 5663, 5517, 5289, 5531, 5438, 5339, 5681, 5321, 5614, 5437, 5541, 5480, 5252, 5591, 5693, 5417, 5644, 5603, 5579, 5509, 5451, 5658, 5486, 5408, 5356, 5583, 5659, 5345, 5647, 5667, 5573, 5384, 5636, 5706, 5675, 5620, 5458, 5350, 5471, 5589, 5662, 5518, 5671, 5453, 5519, 5353, 5521, 5721, 5334, 5343, 5348, 5475, 5719, 5625, 5668, 5661, 5269, 5369, 5575, 5569, 5280, 5515, 5530, 5566, 5467, 5570, 5288, 5431, 5282, 5426 (2 hits)
13	9	1.0	333.0	Yes	5528.0MHz,	5669, 5310, 5679, 5254, 5711, 5295,

					-64.0dBm	5250, 5530, 5434, 5704, 5358, 5426, 5445, 5416, 5406, 5674, 5625, 5394, 5530, 5504, 5673, 5509, 5536, 5450, 5297, 5593, 5478, 5695, 5467, 5441, 5321, 5518, 5665, 5543, 5549, 5383, 5427, 5519, 5605, 5628, 5530, 5592, 5557, 5539, 5345, 5489, 5323, 5566, 5563, 5456, 5702, 5651, 5261, 5380, 5708, 5623, 5626, 5694, 5407, 5372, 5396, 5547, 5339, 5698, 5258, 5298, 5657, 5508, 5718, 5528, 5722, 5308, 5701, 5697, 5590, 5386, 5294, 5327, 5686, 5378, 5607, 5302, 5594, 5713, 5649, 5265, 5371, 5602, 5419, 5340, 5455, 5305, 5408, 5393, 5331, 5414, 5692, 5654, 5452, 5437 (4 hits)
14	9	1.0	333.0	Yes	5529.0MHz, -64.0dBm	5359, 5508, 5493, 5285, 5560, 5649, 5699, 5597, 5256, 5460, 5706, 5572, 5679, 5295, 5637, 5373, 5642, 5538, 5566, 5398, 5445, 5303, 5395, 5403, 5504, 5621, 5459, 5543, 5267, 5717, 5674, 5484, 5655, 5661, 5343, 5672, 5497, 5452, 5531, 5400, 5624, 5594, 5658, 5657, 5652, 5521, 5430, 5687, 5363, 5503, 5487, 5272, 5314, 5461, 5483, 5618, 5292, 5589, 5639, 5507, 5700, 5266, 5377, 5270, 5381, 5662, 5350, 5701, 5443, 5467, 5282, 5528, 5518, 5383, 5667, 5317, 5644, 5464, 5659, 5333, 5548, 5470, 5631, 5525, 5276, 5456, 5376, 5577, 5517, 5301, 5710, 5361, 5584, 5676, 5293, 5670,

						5328, 5650, 5472, 5397 (5 hits)
15	9	1.0	333.0	Yes	5530.0MHz, -64.0dBm	5439, 5405, 5301, 5464, 5551, 5468, 5550, 5607, 5693, 5532, 5371, 5411, 5267, 5590, 5565, 5258, 5537, 5431, 5714, 5342, 5333, 5262, 5367, 5544, 5303, 5707, 5527, 5710, 5359, 5563, 5723, 5554, 5514, 5677, 5504, 5477, 5623, 5582, 5376, 5372, 5327, 5408, 5282, 5451, 5470, 5432, 5305, 5309, 5347, 5259, 5484, 5295, 5561, 5696, 5567, 5628, 5311, 5271, 5650, 5467, 5458, 5407, 5633, 5321, 5552, 5683, 5485, 5720, 5357, 5394, 5673, 5685, 5369, 5399, 5608, 5397, 5692, 5374, 5351, 5635, 5575, 5341, 5263, 5510, 5596, 5456, 5523, 5348, 5519, 5672, 5344, 5560, 5505, 5643, 5540, 5491, 5379, 5273, 5339, 5299 (5 hits)
16	9	1.0	333.0	Yes	5531.0MHz, -64.0dBm	5658, 5510, 5507, 5682, 5381, 5558, 5613, 5514, 5377, 5472, 5669, 5700, 5432, 5265, 5665, 5291, 5625, 5624, 5405, 5531, 5309, 5673, 5463, 5496, 5441, 5587, 5262, 5582, 5689, 5378, 5565, 5351, 5515, 5343, 5347, 5614, 5542, 5382, 5322, 5547, 5408, 5664, 5356, 5280, 5315, 5557, 5439, 5694, 5490, 5434, 5348, 5659, 5714, 5517, 5299, 5267, 5609, 5325, 5526, 5618, 5666, 5446, 5301, 5668, 5655, 5284, 5602, 5464, 5541, 5623, 5519, 5257, 5303, 5254, 5564, 5616, 5485, 5406, 5491, 5294, 5511, 5270, 5263, 5452,

						5617, 5416, 5331, 5361, 5398, 5674, 5593, 5297, 5530, 5345, 5549, 5657, 5445, 5701, 5506, 5690 (2 hits)
17	9	1.0	333.0	Yes	5532.0MHz, -64.0dBm	5526, 5642, 5482, 5593, 5638, 5322, 5311, 5595, 5486, 5636, 5499, 5296, 5401, 5418, 5506, 5370, 5415, 5256, 5539, 5420, 5566, 5557, 5394, 5262, 5284, 5572, 5280, 5564, 5473, 5589, 5313, 5278, 5552, 5722, 5371, 5416, 5303, 5578, 5516, 5292, 5648, 5701, 5717, 5481, 5705, 5618, 5391, 5559, 5272, 5389, 5580, 5592, 5677, 5723, 5690, 5314, 5336, 5612, 5639, 5316, 5659, 5510, 5402, 5411, 5444, 5331, 5657, 5409, 5369, 5560, 5533, 5568, 5649, 5462, 5431, 5364, 5530, 5693, 5654, 5454, 5350, 5429, 5334, 5490, 5320, 5511, 5291, 5608, 5706, 5427, 5619, 5386, 5335, 5484, 5610, 5469, 5263, 5700, 5554, 5586 (3 hits)
18	9	1.0	333.0	Yes	5533.0MHz, -64.0dBm	5685, 5269, 5561, 5498, 5624, 5485, 5363, 5626, 5555, 5530, 5364, 5545, 5702, 5672, 5517, 5616, 5591, 5598, 5688, 5630, 5681, 5413, 5658, 5422, 5430, 5650, 5280, 5679, 5637, 5676, 5722, 5550, 5279, 5575, 5472, 5719, 5711, 5585, 5287, 5706, 5378, 5484, 5569, 5432, 5570, 5649, 5327, 5479, 5587, 5714, 5514, 5256, 5655, 5531, 5408, 5435, 5346, 5622, 5342, 5482, 5347, 5380, 5291, 5362, 5304, 5581, 5718, 5607, 5540, 5660, 5661, 5257,

						5275, 5667, 5442, 5265, 5668, 5470, 5329, 5546, 5338, 5566, 5463, 5282, 5255, 5436, 5641, 5600, 5530, 5396, 5499, 5418, 5671, 5610, 5425, 5481, 5375, 5562, 5377, 5678 (3 hits)
19	9	1.0	333.0	Yes	5534.0MHz, -64.0dBm	5319, 5566, 5387, 5407, 5589, 5482, 5382, 5725, 5722, 5721, 5625, 5552, 5302, 5720, 5305, 5375, 5281, 5263, 5349, 5627, 5336, 5623, 5357, 5573, 5661, 5350, 5271, 5344, 5402, 5446, 5586, 5613, 5598, 5515, 5441, 5667, 5390, 5641, 5520, 5327, 5283, 5422, 5708, 5292, 5645, 5502, 5533, 5687, 5546, 5295, 5374, 5548, 5367, 5273, 5412, 5662, 5592, 5664, 5378, 5723, 5330, 5486, 5682, 5475, 5257, 5508, 5569, 5340, 5376, 5494, 5518, 5696, 5348, 5706, 5334, 5588, 5290, 5684, 5654, 5673, 5491, 5689, 5361, 5317, 5603, 5293, 5602, 5310, 5272, 5329, 5323, 5670, 5675, 5611, 5587, 5386, 5719, 5322, 5700, 5692 (2 hits)
20	9	1.0	333.0	Yes	5535.0MHz, -64.0dBm	5314, 5644, 5654, 5371, 5716, 5696, 5292, 5308, 5454, 5410, 5359, 5640, 5466, 5364, 5462, 5680, 5591, 5479, 5701, 5354, 5616, 5686, 5376, 5316, 5625, 5666, 5338, 5557, 5543, 5663, 5613, 5360, 5280, 5578, 5436, 5679, 5658, 5459, 5512, 5486, 5426, 5526, 5636, 5381, 5546, 5508, 5608, 5723, 5525, 5704, 5409, 5547, 5671, 5266, 5395, 5323, 5461, 5313, 5388, 5284,

						5258, 5687, 5540, 5442, 5345, 5503, 5415, 5510, 5265, 5697, 5380, 5440, 5322, 5472, 5353, 5520, 5428, 5273, 5698, 5643, 5699, 5587, 5489, 5646, 5375, 5691, 5682, 5329, 5592, 5281, 5725, 5274, 5633, 5403, 5301, 5271, 5252, 5411, 5566, 5514 (4 hits)
21	9	1.0	333.0	Yes	5536.0MHz, -64.0dBm	5718, 5712, 5477, 5639, 5329, 5707, 5368, 5279, 5464, 5561, 5569, 5340, 5522, 5723, 5607, 5265, 5423, 5432, 5709, 5311, 5524, 5697, 5496, 5400, 5630, 5684, 5334, 5656, 5377, 5680, 5623, 5270, 5439, 5683, 5381, 5553, 5614, 5255, 5467, 5520, 5575, 5301, 5661, 5337, 5703, 5659, 5606, 5673, 5654, 5530, 5316, 5570, 5395, 5541, 5408, 5466, 5657, 5296, 5462, 5427, 5411, 5584, 5668, 5391, 5636, 5603, 5481, 5373, 5358, 5450, 5343, 5529, 5505, 5694, 5693, 5273, 5441, 5347, 5498, 5264, 5304, 5530, 5651, 5640, 5388, 5415, 5597, 5253, 5530, 5448, 5276, 5663, 5690, 5646, 5482, 5350, 5705, 5596, 5666, 5418 (5 hits)
22	9	1.0	333.0	Yes	5537.0MHz, -64.0dBm	5550, 5511, 5708, 5272, 5382, 5560, 5475, 5672, 5312, 5678, 5649, 5571, 5282, 5574, 5507, 5510, 5613, 5351, 5590, 5354, 5600, 5349, 5647, 5435, 5710, 5504, 5472, 5539, 5299, 5386, 5467, 5665, 5543, 5454, 5696, 5406, 5645, 5623, 5565, 5415, 5276, 5323, 5491, 5335, 5513, 5714, 5629, 5701,

						5566, 5289, 5640, 5378, 5667, 5304, 5441, 5680, 5436, 5483, 5370, 5297, 5639, 5657, 5711, 5432, 5455, 5559, 5697, 5659, 5421, 5599, 5498, 5391, 5310, 5320, 5699, 5530, 5662, 5357, 5448, 5638, 5477, 5582, 5460, 5350, 5580, 5375, 5589, 5493, 5575, 5363, 5588, 5495, 5394, 5518, 5412, 5419, 5689, 5521, 5471, 5625 (2 hits)
23	9	1.0	333.0	Yes	5538.0MHz, -64.0dBm	5606, 5317, 5673, 5340, 5364, 5461, 5721, 5674, 5404, 5646, 5261, 5575, 5577, 5703, 5651, 5293, 5590, 5258, 5397, 5405, 5504, 5707, 5570, 5632, 5450, 5700, 5311, 5341, 5296, 5661, 5485, 5394, 5304, 5664, 5494, 5307, 5512, 5438, 5323, 5445, 5656, 5535, 5308, 5547, 5597, 5613, 5723, 5583, 5391, 5495, 5274, 5525, 5434, 5401, 5709, 5614, 5253, 5277, 5543, 5698, 5454, 5390, 5486, 5571, 5559, 5601, 5359, 5444, 5669, 5653, 5437, 5386, 5353, 5497, 5349, 5256, 5483, 5556, 5529, 5365, 5399, 5566, 5381, 5558, 5269, 5457, 5446, 5345, 5313, 5431, 5472, 5400, 5507, 5413, 5294, 5388, 5681, 5627, 5480, 5506 (3 hits)
24	9	1.0	333.0	Yes	5539.0MHz, -64.0dBm	5694, 5269, 5444, 5603, 5386, 5490, 5604, 5456, 5368, 5559, 5649, 5366, 5716, 5482, 5704, 5283, 5691, 5293, 5373, 5501, 5541, 5419, 5400, 5391, 5382, 5365, 5429, 5343, 5336, 5264, 5713, 5494, 5572, 5643, 5375, 5395,

						5634, 5627, 5626, 5426, 5440, 5599, 5510, 5406, 5298, 5256, 5573, 5291, 5349, 5258, 5443, 5724, 5414, 5636, 5330, 5641, 5455, 5342, 5347, 5265, 5492, 5625, 5560, 5333, 5658, 5589, 5486, 5693, 5447, 5516, 5467, 5592, 5453, 5555, 5484, 5324, 5590, 5600, 5566, 5619, 5637, 5272, 5255, 5348, 5277, 5418, 5351, 5452, 5543, 5317, 5545, 5659, 5252, 5416, 5491, 5660, 5282, 5470, 5698, 5540 (1 hits)
25	9	1.0	333.0	Yes	5540.0MHz, -64.0dBm	5572, 5662, 5334, 5250, 5512, 5557, 5437, 5375, 5433, 5426, 5379, 5640, 5580, 5534, 5699, 5360, 5321, 5428, 5510, 5277, 5722, 5538, 5442, 5507, 5435, 5706, 5358, 5304, 5383, 5701, 5655, 5553, 5380, 5628, 5674, 5520, 5479, 5615, 5709, 5714, 5506, 5365, 5707, 5346, 5617, 5550, 5444, 5338, 5644, 5566, 5549, 5693, 5697, 5374, 5577, 5402, 5477, 5251, 5407, 5384, 5415, 5361, 5295, 5497, 5584, 5555, 5323, 5591, 5680, 5620, 5669, 5326, 5404, 5266, 5541, 5430, 5412, 5356, 5343, 5657, 5668, 5328, 5526, 5653, 5446, 5475, 5545, 5578, 5355, 5630, 5595, 5376, 5484, 5556, 5392, 5351, 5582, 5405, 5456, 5462 (4 hits)
26	9	1.0	333.0	Yes	5541.0MHz, -64.0dBm	5324, 5402, 5357, 5520, 5489, 5536, 5427, 5525, 5390, 5497, 5644, 5309, 5657, 5482, 5307, 5458, 5561, 5527, 5412, 5514, 5636, 5362, 5270, 5696,

						5572, 5680, 5484, 5678, 5689, 5364, 5578, 5395, 5388, 5367, 5348, 5339, 5331, 5292, 5330, 5380, 5516, 5285, 5699, 5447, 5641, 5418, 5428, 5432, 5369, 5697, 5492, 5534, 5349, 5672, 5289, 5583, 5511, 5336, 5633, 5713, 5265, 5668, 5294, 5639, 5251, 5370, 5568, 5577, 5422, 5469, 5437, 5586, 5642, 5663, 5649, 5366, 5512, 5495, 5280, 5640, 5325, 5628, 5643, 5266, 5524, 5518, 5575, 5508, 5493, 5521, 5452, 5485, 5710, 5588, 5523, 5611, 5377, 5323, 5664, 5587 (8 hits)
27	9	1.0	333.0	Yes	5542.0MHz, -64.0dBm	5400, 5577, 5610, 5406, 5253, 5458, 5391, 5594, 5554, 5308, 5357, 5696, 5338, 5541, 5642, 5311, 5607, 5581, 5439, 5396, 5650, 5677, 5598, 5478, 5540, 5566, 5293, 5616, 5332, 5565, 5440, 5655, 5331, 5563, 5552, 5721, 5579, 5270, 5423, 5582, 5453, 5647, 5558, 5466, 5702, 5359, 5644, 5304, 5275, 5514, 5658, 5460, 5605, 5714, 5492, 5591, 5282, 5484, 5388, 5649, 5511, 5587, 5381, 5257, 5472, 5543, 5641, 5636, 5261, 5394, 5498, 5412, 5620, 5651, 5608, 5469, 5430, 5384, 5252, 5442, 5403, 5376, 5602, 5464, 5462, 5377, 5569, 5567, 5437, 5325, 5416, 5327, 5601, 5630, 5267, 5356, 5364, 5545, 5291, 5548 (1 hits)
28	9	1.0	333.0	Yes	5543.0MHz, -64.0dBm	5616, 5570, 5491, 5602, 5398, 5576, 5683, 5396, 5381, 5569, 5594, 5294,

						5696, 5250, 5320, 5446, 5641, 5533, 5677, 5476, 5634, 5256, 5378, 5488, 5644, 5362, 5252, 5384, 5302, 5318, 5719, 5588, 5342, 5383, 5595, 5449, 5705, 5363, 5724, 5607, 5473, 5640, 5453, 5359, 5523, 5686, 5720, 5351, 5655, 5672, 5658, 5646, 5411, 5399, 5286, 5436, 5503, 5698, 5559, 5606, 5630, 5283, 5535, 5413, 5402, 5457, 5428, 5332, 5499, 5725, 5674, 5687, 5524, 5666, 5475, 5405, 5699, 5375, 5438, 5327, 5353, 5373, 5532, 5610, 5557, 5387, 5427, 5275, 5296, 5581, 5326, 5530, 5253, 5276, 5560, 5393, 5625, 5598, 5565, 5692 (5 hits)
29	9	1.0	333.0	Yes	5544.0MHz, -64.0dBm	5362, 5509, 5648, 5724, 5640, 5702, 5639, 5534, 5341, 5637, 5633, 5393, 5414, 5286, 5719, 5692, 5569, 5349, 5514, 5291, 5331, 5474, 5258, 5388, 5310, 5375, 5361, 5510, 5386, 5605, 5693, 5545, 5408, 5497, 5259, 5278, 5642, 5456, 5654, 5625, 5582, 5373, 5460, 5499, 5381, 5485, 5723, 5678, 5658, 5384, 5649, 5412, 5441, 5553, 5351, 5449, 5477, 5306, 5671, 5561, 5308, 5280, 5285, 5415, 5533, 5714, 5271, 5295, 5382, 5339, 5687, 5572, 5322, 5588, 5489, 5652, 5345, 5513, 5560, 5684, 5253, 5380, 5711, 5303, 5523, 5287, 5542, 5537, 5343, 5710, 5540, 5327, 5712, 5277, 5538, 5596, 5565, 5595, 5579, 5694 (6 hits)

Table 8 FCC& RSS-210 frequency hopping radar (Type 6) Test Results

Long Sequence Trial	Result	Radar Frequency / Amplitude
Trial #1	Detected	5530.0MHz, -64.0dBm
Trial #2	Detected	5530.0MHz, -64.0dBm
Trial #3	Detected	5530.0MHz, -64.0dBm
Trial #4	Detected	5530.0MHz, -64.0dBm
Trial #5	Detected	5530.0MHz, -64.0dBm
Trial #6	Detected	5530.0MHz, -64.0dBm
Trial #7	Detected	5530.0MHz, -64.0dBm
Trial #8	Detected	5530.0MHz, -64.0dBm
Trial #9	Detected	5530.0MHz, -64.0dBm
Trial #10	Detected	5530.0MHz, -64.0dBm
Trial #11	Detected	5530.0MHz, -64.0dBm
Trial #12	Detected	5530.0MHz, -64.0dBm
Trial #13	Detected	5530.0MHz, -64.0dBm
Trial #14	Detected	5530.0MHz, -64.0dBm
Trial #15	Detected	5530.0MHz, -64.0dBm
Trial #16	Detected	5530.0MHz, -64.0dBm
Trial #17	Detected	5530.0MHz, -64.0dBm
Trial #18	Detected	5530.0MHz, -64.0dBm
Trial #19	Detected	5530.0MHz, -64.0dBm
Trial #20	Detected	5530.0MHz, -64.0dBm
Trial #21	Detected	5530.0MHz, -64.0dBm
Trial #22	Detected	5530.0MHz,

		-64.0dBm
Trial #23	Detected	5530.0MHz, -64.0dBm
Trial #24	Detected	5530.0MHz, -64.0dBm
Trial #25	Detected	5530.0MHz, -64.0dBm
Trial #26	Detected	5530.0MHz, -64.0dBm
Trial #27	Detected	5530.0MHz, -64.0dBm
Trial #28	Detected	5530.0MHz, -64.0dBm
Trial #29	Detected	5530.0MHz, -64.0dBm
Trial #30	Detected	5530.0MHz, -64.0dBm

Table 9 Long Sequence Waveform Summary

Burst #	# Pulses	Pulse Width (us)	Chirp (MHz)	Interval 1 to 2 (us)	Interval 2 to 3 (us)	Start time (us)
0	1	50.1	8	-	-	0.291939
1	2	75.2	16	1889.0	-	1.700961
2	1	99.4	8	-	-	2.045588
3	2	98.8	14	1437.0	-	3.239909
4	3	61.1	18	1352.0	1145.0	3.430721
5	2	61.6	7	1465.0	-	4.975652
6	2	62.0	7	1559.0	-	5.149326
7	2	51.8	15	1891.0	-	6.447130
8	1	75.8	18	-	-	7.272255
9	2	50.1	10	1657.0	-	8.403782
10	2	67.7	14	1459.0	-	8.833092
11	1	84.4	16	-	-	10.217899
12	1	94.6	19	-	-	10.919533
13	2	79.9	18	1040.0	-	11.966260

Table 10 Long Sequence Waveform Trial#1 (Detected)

Burst #	# Pulses	Pulse Width (us)	Chirp (MHz)	Interval 1 to 2 (us)	Interval 2 to 3 (us)	Start time (us)
0	3	98.6	10	1911.0	1209.0	1.034488
1	2	85.9	12	1726.0	-	2.209267
2	2	72.2	20	1629.0	-	4.075625
3	2	78.9	11	1212.0	-	4.755317
4	1	58.6	18	-	-	7.357471
5	1	87.6	14	-	-	8.706369
6	2	59.8	19	1715.0	-	10.430392
7	2	59.8	12	1300.0	-	11.522349

Table 11 Long Sequence Waveform Trial#2 (Detected)

Burst #	# Pulses	Pulse Width (us)	Chirp (MHz)	Interval 1 to 2 (us)	Interval 2 to 3 (us)	Start time (us)
0	3	95.0	10	1107.0	1373.0	0.353857
1	2	86.3	18	1613.0	-	1.787445
2	2	84.9	11	1918.0	-	2.496612
3	2	83.9	11	1270.0	-	3.685492
4	1	74.5	9	-	-	4.067972
5	2	57.3	15	1984.0	-	5.050877
6	2	97.5	10	1731.0	-	6.272668
7	2	81.8	14	1868.0	-	6.952618
8	1	99.8	16	-	-	7.883091
9	2	71.8	18	1801.0	-	8.539908
10	2	63.4	6	1020.0	-	9.513440
11	2	73.6	19	1318.0	-	10.256189
12	2	83.3	11	1066.0	-	11.523121

Table 12 Long Sequence Waveform Trial#3 (Detected)

Burst #	# Pulses	Pulse Width (us)	Chirp (MHz)	Interval 1 to 2 (us)	Interval 2 to 3 (us)	Start time (us)
0	1	66.0	10	-	-	0.796159
1	2	88.0	17	1953.0	-	0.989680
2	1	61.5	20	-	-	2.387037
3	2	52.9	9	1211.0	-	2.956860
4	2	62.4	5	1005.0	-	3.397009
5	1	73.6	17	-	-	4.234252
6	1	71.5	8	-	-	5.069176
7	2	52.2	17	1183.0	-	5.995703
8	1	63.1	19	-	-	6.915514
9	2	78.9	13	1245.0	-	7.625366
10	2	50.7	7	1443.0	-	8.368676
11	2	90.7	5	1116.0	-	9.012394
12	2	76.8	20	1353.0	-	9.640022
13	2	70.7	6	1589.0	-	10.432737
14	2	90.0	12	1669.0	-	11.722647

Table 13 Long Sequence Waveform Trial#4 (Detected)

Burst #	# Pulses	Pulse Width (us)	Chirp (MHz)	Interval 1 to 2 (us)	Interval 2 to 3 (us)	Start time (us)
0	2	96.3	11	1798.0	-	0.426415
1	1	54.8	16	-	-	1.314094
2	3	59.2	13	1539.0	1126.0	2.239563
3	3	97.8	8	1811.0	1171.0	3.507386
4	3	50.7	12	1418.0	1943.0	4.387145
5	3	74.3	7	1787.0	1935.0	5.257908
6	1	50.6	7	-	-	5.816433
7	2	58.7	19	1087.0	-	7.015411
8	2	80.2	12	1001.0	-	7.979507
9	2	73.1	20	1246.0	-	8.911599
10	2	87.9	13	1579.0	-	10.096875
11	2	83.8	18	1354.0	-	10.914973
12	1	52.7	11	-	-	11.735206

Table 14 Long Sequence Waveform Trial#5 (Detected)

Burst #	# Pulses	Pulse Width (us)	Chirp (MHz)	Interval 1 to 2 (us)	Interval 2 to 3 (us)	Start time (us)
0	2	86.1	15	1436.0	-	0.702779
1	3	52.4	13	1670.0	1177.0	0.987411
2	2	94.3	18	1530.0	-	2.050846
3	2	72.9	5	1521.0	-	2.613055
4	1	97.5	18	-	-	3.462137
5	2	69.1	6	1020.0	-	3.791872
6	2	81.8	11	1930.0	-	4.681283
7	1	72.5	15	-	-	5.093288
8	2	70.5	6	1500.0	-	5.965421
9	1	92.7	16	-	-	7.039024
10	2	81.0	15	1356.0	-	7.285150
11	2	92.4	16	1163.0	-	8.127237
12	2	91.1	12	1507.0	-	9.131026
13	2	83.0	7	1994.0	-	9.447799
14	2	67.6	6	1435.0	-	9.967923
15	1	58.6	7	-	-	10.644637
16	2	93.9	11	1881.0	-	11.837799

Table 15 Long Sequence Waveform Trial#6 (Detected)

Burst #	# Pulses	Pulse Width (us)	Chirp (MHz)	Interval 1 to 2 (us)	Interval 2 to 3 (us)	Start time (us)
0	2	64.6	6	1997.0	-	0.217150
1	2	81.6	11	1426.0	-	1.031591
2	2	70.9	20	1412.0	-	2.823159
3	2	59.5	16	1888.0	-	3.918066
4	2	77.8	10	1624.0	-	4.952480
5	3	52.5	8	1658.0	1750.0	5.691161
6	2	87.3	13	1462.0	-	6.045489
7	2	55.4	7	1799.0	-	7.276046
8	2	97.7	19	1209.0	-	8.715326
9	3	76.5	6	1348.0	1898.0	9.138042
10	1	69.4	19	-	-	10.329523
11	2	80.2	19	1748.0	-	11.853825

Table 16 Long Sequence Waveform Trial#7 (Detected)

Burst #	# Pulses	Pulse Width (us)	Chirp (MHz)	Interval 1 to 2 (us)	Interval 2 to 3 (us)	Start time (us)
0	1	51.5	15	-	-	0.067371
1	1	67.0	17	-	-	1.394495
2	3	55.7	9	1045.0	1170.0	2.046733
3	1	79.1	10	-	-	3.377380
4	2	62.5	16	1133.0	-	4.964029
5	2	68.2	19	1337.0	-	5.811817
6	2	64.1	15	1738.0	-	6.986201
7	3	74.4	15	1672.0	1015.0	7.023754
8	1	64.3	7	-	-	8.258039
9	2	67.2	9	1418.0	-	9.268661
10	1	62.5	18	-	-	10.701417
11	2	60.3	15	1637.0	-	11.982500

Table 17 Long Sequence Waveform Trial#8 (Detected)

Burst #	# Pulses	Pulse Width (us)	Chirp (MHz)	Interval 1 to 2 (us)	Interval 2 to 3 (us)	Start time (us)
0	3	91.2	15	1642.0	1779.0	0.334253
1	3	51.7	8	1545.0	1197.0	1.041498
2	3	53.7	17	1527.0	1705.0	2.044289
3	2	68.0	11	1241.0	-	3.422773
4	3	84.9	12	1732.0	1400.0	4.150206
5	1	55.8	11	-	-	5.039999
6	3	75.7	13	1534.0	1755.0	6.595937
7	2	88.0	16	1752.0	-	7.789218
8	2	87.1	14	1873.0	-	8.800757
9	2	87.4	15	1369.0	-	9.015854
10	1	69.0	8	-	-	10.088398
11	1	71.3	18	-	-	11.111305

Table 18 Long Sequence Waveform Trial#9 (Detected)

Burst #	# Pulses	Pulse Width (us)	Chirp (MHz)	Interval 1 to 2 (us)	Interval 2 to 3 (us)	Start time (us)
0	2	57.6	13	1324.0	-	0.000403
1	2	84.0	12	1477.0	-	1.607083
2	2	73.9	11	1747.0	-	2.591772
3	2	64.9	13	1822.0	-	4.214168
4	1	73.6	5	-	-	5.344649
5	3	90.2	12	1102.0	1697.0	6.136209
6	1	77.9	12	-	-	8.112550
7	2	62.4	6	1726.0	-	8.723168
8	2	53.1	18	1323.0	-	10.303739
9	3	54.4	8	1406.0	1367.0	11.337255

Table 19 Long Sequence Waveform Trial#10 (Detected)

Burst #	# Pulses	Pulse Width (us)	Chirp (MHz)	Interval 1 to 2 (us)	Interval 2 to 3 (us)	Start time (us)
0	1	84.1	20	-	-	0.360654
1	2	52.2	6	1931.0	-	0.659646
2	3	75.4	17	1729.0	1813.0	1.577415
3	2	51.2	13	1677.0	-	2.076862
4	2	59.1	18	1476.0	-	2.567154
5	2	73.6	18	1325.0	-	3.786014
6	1	56.3	15	-	-	4.187759
7	3	95.1	12	1301.0	1608.0	4.968945
8	2	75.3	6	1687.0	-	5.656411
9	3	99.5	12	1531.0	1415.0	5.804145
10	2	95.3	8	1184.0	-	6.377796
11	2	84.3	13	1602.0	-	7.191574
12	3	71.8	18	1130.0	1169.0	8.143710
13	1	65.4	7	-	-	8.279260
14	1	74.8	14	-	-	9.163332
15	2	59.1	7	1522.0	-	9.706091
16	2	54.6	13	1591.0	-	10.354212
17	2	99.7	7	1695.0	-	10.789364
18	1	89.2	15	-	-	11.535821

Table 20 Long Sequence Waveform Trial#11 (Detected)

Burst #	# Pulses	Pulse Width (us)	Chirp (MHz)	Interval 1 to 2 (us)	Interval 2 to 3 (us)	Start time (us)
0	2	61.7	14	1562.0	-	0.709851
1	2	96.5	8	1871.0	-	0.910738
2	2	54.2	18	1098.0	-	2.069455
3	2	80.7	12	1762.0	-	2.645919
4	2	88.7	8	1334.0	-	3.347611
5	1	55.3	12	-	-	4.476921
6	2	92.3	6	1405.0	-	5.352131
7	3	90.7	13	1141.0	1712.0	5.798177
8	3	95.8	8	1594.0	1522.0	7.154835
9	2	87.9	7	1375.0	-	7.662497
10	2	97.0	13	1846.0	-	8.079287
11	2	87.8	7	1796.0	-	9.314495
12	3	87.5	14	1038.0	1512.0	10.200634
13	1	94.9	9	-	-	11.138844
14	2	61.0	11	1576.0	-	11.644524

Table 21 Long Sequence Waveform Trial#12 (Detected)

Burst #	# Pulses	Pulse Width (us)	Chirp (MHz)	Interval 1 to 2 (us)	Interval 2 to 3 (us)	Start time (us)
0	2	56.7	12	1537.0	-	0.514624
1	3	79.5	13	1597.0	1287.0	1.430137
2	2	89.3	16	1572.0	-	3.123326
3	2	83.4	17	1306.0	-	4.064187
4	2	88.3	11	1076.0	-	5.208625
5	2	58.1	7	1552.0	-	6.926894
6	1	64.2	5	-	-	8.003356
7	3	84.3	14	1030.0	1372.0	8.578852
8	3	57.9	13	1516.0	1479.0	10.089785
9	3	56.3	7	1454.0	1059.0	11.002952

Table 22 Long Sequence Waveform Trial#13 (Detected)

Burst #	# Pulses	Pulse Width (us)	Chirp (MHz)	Interval 1 to 2 (us)	Interval 2 to 3 (us)	Start time (us)
0	2	52.4	7	1500.0	-	0.369702
1	2	59.1	8	1463.0	-	0.691282
2	3	82.0	19	1753.0	1398.0	1.991127
3	2	54.1	11	1758.0	-	2.210901
4	2	59.8	13	1242.0	-	2.941704
5	2	90.5	7	1133.0	-	3.442548
6	1	77.3	19	-	-	4.586012
7	2	81.1	11	1648.0	-	4.781641
8	2	58.8	8	1076.0	-	5.412345
9	1	55.4	14	-	-	6.563097
10	2	77.6	14	1694.0	-	7.250075
11	2	76.1	20	1917.0	-	7.547045
12	2	70.6	6	1371.0	-	8.017037
13	2	55.3	11	1548.0	-	9.164445
14	3	60.1	11	1729.0	1796.0	9.831889
15	3	66.8	10	1890.0	1443.0	10.573053
16	2	78.3	8	1251.0	-	10.701609
17	2	55.3	14	1016.0	-	11.624365

Table 23 Long Sequence Waveform Trial#14 (Detected)

Burst #	# Pulses	Pulse Width (us)	Chirp (MHz)	Interval 1 to 2 (us)	Interval 2 to 3 (us)	Start time (us)
0	2	62.2	15	1383.0	-	0.396874
1	2	70.6	9	1720.0	-	0.753889
2	3	64.6	9	1813.0	1576.0	1.518653
3	3	94.6	20	1706.0	1596.0	2.363822
4	1	56.3	12	-	-	2.670206
5	2	94.0	12	1491.0	-	3.760184
6	2	90.9	16	1362.0	-	4.185527
7	3	89.8	7	1085.0	1522.0	4.749441
8	2	95.5	12	1632.0	-	5.274687
9	2	68.6	14	1244.0	-	6.122158
10	2	55.9	15	1014.0	-	6.631838
11	2	97.7	8	1419.0	-	6.996489
12	2	85.0	6	1313.0	-	7.612661
13	1	75.8	17	-	-	8.559499
14	1	79.3	10	-	-	9.288998
15	1	85.8	18	-	-	9.828525
16	3	94.2	8	1423.0	1665.0	10.711253
17	1	76.4	14	-	-	10.943373
18	2	93.4	12	1444.0	-	11.896292

Table 24 Long Sequence Waveform Trial#15 (Detected)

Burst #	# Pulses	Pulse Width (us)	Chirp (MHz)	Interval 1 to 2 (us)	Interval 2 to 3 (us)	Start time (us)
0	3	58.1	11	1045.0	1460.0	0.795346
1	2	57.2	7	1765.0	-	2.409082
2	2	61.7	7	1278.0	-	3.845784
3	2	61.1	17	1635.0	-	4.859343
4	1	64.1	7	-	-	6.126456
5	2	70.9	17	1753.0	-	7.024117
6	1	77.8	7	-	-	8.433478
7	3	85.1	15	1679.0	1050.0	9.407503
8	3	54.4	6	1904.0	1475.0	11.719377

Table 25 Long Sequence Waveform Trial#16 (Detected)

Burst #	# Pulses	Pulse Width (us)	Chirp (MHz)	Interval 1 to 2 (us)	Interval 2 to 3 (us)	Start time (us)
0	2	85.1	10	1621.0	-	0.304482
1	2	90.8	14	1537.0	-	1.288867
2	2	70.9	8	1851.0	-	2.297812
3	2	90.3	19	1237.0	-	3.249041
4	3	59.6	11	1483.0	1410.0	4.038349
5	2	75.7	18	1765.0	-	5.902391
6	2	80.2	6	1327.0	-	6.221478
7	2	91.6	17	1448.0	-	7.647046
8	2	98.6	8	1413.0	-	8.700502
9	1	57.9	8	-	-	9.819809
10	2	66.8	7	1472.0	-	10.652103
11	2	56.0	18	1724.0	-	11.121512

Table 26 Long Sequence Waveform Trial#17 (Detected)

Burst #	# Pulses	Pulse Width (us)	Chirp (MHz)	Interval 1 to 2 (us)	Interval 2 to 3 (us)	Start time (us)
0	1	74.1	12	-	-	1.032140
1	2	71.3	15	1724.0	-	1.670042
2	2	82.2	11	1125.0	-	3.118553
3	2	66.8	20	1129.0	-	3.637785
4	2	99.8	16	1628.0	-	4.843679
5	3	69.9	19	1787.0	1381.0	5.981799
6	3	54.1	5	1750.0	1909.0	7.039374
7	2	68.6	18	1590.0	-	7.643186
8	3	60.4	9	1980.0	1708.0	9.166365
9	2	74.9	7	1785.0	-	10.624272
10	2	85.7	6	1524.0	-	11.277145

Table 27 Long Sequence Waveform Trial#18 (Detected)

Burst #	# Pulses	Pulse Width (us)	Chirp (MHz)	Interval 1 to 2 (us)	Interval 2 to 3 (us)	Start time (us)
0	2	82.6	7	1989.0	-	0.671768
1	3	87.8	12	1687.0	1537.0	2.525642
2	2	86.7	16	1645.0	-	2.898097
3	3	94.5	19	1566.0	1728.0	4.067712
4	3	73.5	19	1829.0	1238.0	5.525701
5	3	87.0	16	1103.0	1713.0	7.231851
6	2	92.7	14	1570.0	-	8.834109
7	2	63.8	17	1133.0	-	10.157194
8	2	75.1	6	1118.0	-	10.884411

Table 28 Long Sequence Waveform Trial#19 (Detected)

Burst #	# Pulses	Pulse Width (us)	Chirp (MHz)	Interval 1 to 2 (us)	Interval 2 to 3 (us)	Start time (us)
0	2	80.6	9	1644.0	-	0.480625
1	2	73.0	6	1439.0	-	1.531906
2	1	72.1	20	-	-	1.683135
3	1	69.0	16	-	-	2.983101
4	3	85.7	16	1221.0	1355.0	3.434671
5	1	63.5	20	-	-	4.789695
6	2	83.1	6	1339.0	-	4.952135
7	3	64.0	5	1443.0	1573.0	5.705962
8	2	53.1	8	1890.0	-	6.931929
9	3	92.5	10	1263.0	1452.0	7.396651
10	2	53.0	18	1907.0	-	8.615645
11	2	62.1	7	1410.0	-	8.877426
12	1	74.6	19	-	-	10.211282
13	3	59.8	12	1413.0	1037.0	11.046840
14	2	58.8	12	1384.0	-	11.910327

Table 29 Long Sequence Waveform Trial#20 (Detected)

Burst #	# Pulses	Pulse Width (us)	Chirp (MHz)	Interval 1 to 2 (us)	Interval 2 to 3 (us)	Start time (us)
0	3	70.4	18	1613.0	1030.0	0.207961
1	1	67.5	6	-	-	1.100081
2	3	78.0	17	1121.0	1438.0	1.496514
3	3	85.7	7	1970.0	1146.0	2.132333
4	2	83.3	16	1766.0	-	2.905191
5	2	55.8	13	1763.0	-	3.671224
6	1	73.8	18	-	-	4.246657
7	1	72.0	10	-	-	4.698366
8	3	87.4	16	1851.0	1068.0	5.637683
9	1	62.7	10	-	-	6.021831
10	3	53.6	18	1282.0	1252.0	7.182979
11	2	66.0	14	1425.0	-	7.463016
12	1	92.9	11	-	-	8.310571
13	3	55.6	15	1756.0	1776.0	8.779627
14	3	79.9	7	1038.0	1305.0	9.522247
15	2	50.5	19	1069.0	-	10.497956
16	2	98.7	6	1983.0	-	10.845715
17	2	51.8	15	1039.0	-	11.397928

Table 30 Long Sequence Waveform Trial#21 (Detected)

Burst #	# Pulses	Pulse Width (us)	Chirp (MHz)	Interval 1 to 2 (us)	Interval 2 to 3 (us)	Start time (us)
0	2	53.4	6	1498.0	-	0.240410
1	2	95.7	15	1637.0	-	1.311024
2	3	68.3	18	1915.0	1146.0	1.671282
3	3	98.8	19	1312.0	1912.0	2.135693
4	2	75.7	18	1067.0	-	2.799701
5	1	65.8	17	-	-	3.360474
6	2	89.1	8	1561.0	-	4.428580
7	2	85.5	16	1479.0	-	4.786372
8	1	84.5	19	-	-	5.712820
9	2	75.3	10	1429.0	-	6.029885
10	3	69.2	14	1484.0	1244.0	6.949732
11	2	95.6	16	1493.0	-	7.784797
12	3	66.8	12	1756.0	1897.0	8.272631
13	3	62.3	10	1267.0	1237.0	8.774614
14	3	77.9	10	1946.0	1861.0	9.527723
15	1	57.3	16	-	-	10.421982
16	2	75.8	6	1203.0	-	10.817647
17	2	72.2	14	1700.0	-	11.591924

Table 31 Long Sequence Waveform Trial#22 (Detected)

Burst #	# Pulses	Pulse Width (us)	Chirp (MHz)	Interval 1 to 2 (us)	Interval 2 to 3 (us)	Start time (us)
0	3	76.0	17	1346.0	1190.0	0.525505
1	2	90.5	7	1896.0	-	1.204278
2	2	98.0	8	1267.0	-	2.901124
3	3	78.1	14	1096.0	1070.0	3.331259
4	3	79.7	7	1425.0	1783.0	4.338420
5	2	56.6	15	1120.0	-	5.050680
6	2	79.3	5	1732.0	-	6.846099
7	2	61.2	17	1070.0	-	7.750971
8	2	51.0	16	1373.0	-	8.538758
9	2	91.4	19	1843.0	-	9.252450
10	2	93.6	14	1010.0	-	10.651931
11	3	93.6	17	1016.0	1517.0	11.541456

Table 32 Long Sequence Waveform Trial#23 (Detected)

Burst #	# Pulses	Pulse Width (us)	Chirp (MHz)	Interval 1 to 2 (us)	Interval 2 to 3 (us)	Start time (us)
0	1	90.1	17	-	-	1.014830
1	2	64.5	6	1203.0	-	1.400466
2	1	82.2	12	-	-	2.189427
3	2	98.5	9	1139.0	-	3.845407
4	1	68.9	9	-	-	4.947157
5	2	93.7	7	1701.0	-	6.423421
6	3	80.5	14	1121.0	1312.0	7.436071
7	2	72.2	5	1861.0	-	7.861651
8	3	79.1	19	1556.0	1058.0	9.488415
9	1	56.6	10	-	-	9.970650
10	2	60.7	13	1658.0	-	11.586248

Table 33 Long Sequence Waveform Trial#24 (Detected)

Burst #	# Pulses	Pulse Width (us)	Chirp (MHz)	Interval 1 to 2 (us)	Interval 2 to 3 (us)	Start time (us)
0	1	74.0	12	-	-	0.592485
1	2	81.0	11	1490.0	-	1.319624
2	2	57.6	18	1732.0	-	2.956741
3	2	73.1	15	1399.0	-	3.793025
4	3	52.8	20	1286.0	1174.0	4.229875
5	2	98.4	7	1341.0	-	5.177924
6	2	79.0	17	1641.0	-	6.259544
7	2	81.2	18	1937.0	-	7.683258
8	2	62.0	16	1663.0	-	8.882984
9	1	97.2	19	-	-	9.668923
10	2	79.0	8	1993.0	-	10.226239
11	3	78.1	15	1608.0	1646.0	11.318754

Table 34 Long Sequence Waveform Trial#25 (Detected)

Burst #	# Pulses	Pulse Width (us)	Chirp (MHz)	Interval 1 to 2 (us)	Interval 2 to 3 (us)	Start time (us)
0	2	90.8	12	1434.0	-	0.113417
1	3	58.1	7	1426.0	1494.0	1.836884
2	2	74.9	7	1590.0	-	2.739537
3	2	93.8	9	1416.0	-	3.369732
4	2	66.0	20	1949.0	-	3.703033
5	1	69.3	9	-	-	4.901719
6	3	83.1	17	1207.0	1119.0	6.087894
7	3	90.6	19	1510.0	1810.0	6.608801
8	3	70.1	6	1427.0	1075.0	7.937938
9	3	83.6	11	1924.0	1043.0	8.553263
10	2	87.2	17	1881.0	-	9.933234
11	2	76.2	10	1134.0	-	10.835856
12	2	80.3	15	1580.0	-	11.528982

Table 35 Long Sequence Waveform Trial#26 (Detected)

Burst #	# Pulses	Pulse Width (us)	Chirp (MHz)	Interval 1 to 2 (us)	Interval 2 to 3 (us)	Start time (us)
0	2	81.1	18	1596.0	-	0.072303
1	2	99.5	11	1132.0	-	1.170048
2	3	95.9	11	1923.0	1194.0	1.373405
3	3	87.4	18	1607.0	1960.0	2.443549
4	2	96.8	8	1965.0	-	2.743717
5	3	57.1	19	1964.0	1146.0	3.723838
6	3	54.0	12	1638.0	1651.0	3.905633
7	1	82.4	14	-	-	4.530512
8	2	55.9	17	1569.0	-	5.426290
9	1	78.8	12	-	-	6.012284
10	2	96.7	5	1239.0	-	6.361481
11	2	76.9	10	1060.0	-	7.403904
12	1	79.8	9	-	-	8.076691
13	3	67.1	20	1412.0	1020.0	8.668953
14	3	83.5	8	1330.0	1698.0	8.976584
15	1	79.5	18	-	-	9.674701
16	2	64.1	14	1216.0	-	10.657922
17	2	53.9	16	1842.0	-	10.795367
18	1	79.2	11	-	-	11.890738

Table 36 Long Sequence Waveform Trial#27 (Detected)

Burst #	# Pulses	Pulse Width (us)	Chirp (MHz)	Interval 1 to 2 (us)	Interval 2 to 3 (us)	Start time (us)
0	2	64.9	11	1309.0	-	0.540670
1	3	80.0	14	1771.0	1185.0	1.223696
2	1	82.3	16	-	-	1.360721
3	3	95.1	16	1043.0	1093.0	2.039408
4	3	88.0	9	1377.0	1387.0	2.940057
5	2	86.3	13	1435.0	-	3.771565
6	2	87.4	8	1016.0	-	4.158443
7	2	91.7	7	1814.0	-	5.293967
8	1	73.1	17	-	-	5.448343
9	2	68.8	19	1126.0	-	6.395596
10	3	54.1	6	1998.0	1170.0	7.284859
11	1	75.6	6	-	-	7.509857
12	2	80.9	12	1728.0	-	8.505011
13	1	73.9	15	-	-	8.987253
14	2	81.3	20	1553.0	-	9.435763
15	1	82.2	19	-	-	10.613936
16	3	65.3	11	1818.0	1780.0	10.844777
17	2	84.0	12	1254.0	-	11.401364

Table 37 Long Sequence Waveform Trial#28 (Detected)

Burst #	# Pulses	Pulse Width (us)	Chirp (MHz)	Interval 1 to 2 (us)	Interval 2 to 3 (us)	Start time (us)
0	3	95.1	13	1424.0	1529.0	0.421427
1	2	54.8	16	1437.0	-	0.982656
2	3	74.8	6	1003.0	1209.0	1.899770
3	2	87.4	18	1323.0	-	2.728257
4	2	86.5	8	1255.0	-	3.060033
5	3	71.4	18	1009.0	1768.0	4.034479
6	3	74.3	16	1980.0	1905.0	5.047724
7	1	65.7	14	-	-	5.482489
8	2	87.0	14	1436.0	-	6.045085
9	2	90.0	15	1880.0	-	7.148182
10	2	90.8	13	1663.0	-	7.546671
11	2	64.6	16	1959.0	-	8.571689
12	2	58.9	8	1983.0	-	9.691602
13	3	58.9	15	1089.0	1684.0	10.495499
14	3	55.8	19	1756.0	1791.0	10.988471
15	3	77.6	8	1947.0	1203.0	11.681525

Table 38 Long Sequence Waveform Trial#29 (Detected)

Burst #	# Pulses	Pulse Width (us)	Chirp (MHz)	Interval 1 to 2 (us)	Interval 2 to 3 (us)	Start time (us)
0	2	67.7	8	1920.0	-	0.619240
1	2	75.3	9	1558.0	-	1.685735
2	2	70.8	12	1669.0	-	2.588514
3	3	50.5	16	1876.0	1577.0	3.377257
4	3	85.3	13	1491.0	1332.0	3.780497
5	2	93.3	14	1154.0	-	4.644828
6	3	54.9	6	1162.0	1230.0	5.952439
7	2	65.7	14	1911.0	-	7.355224
8	1	62.5	12	-	-	7.980734
9	2	94.0	19	1227.0	-	8.366227
10	1	91.0	10	-	-	9.293291
11	1	61.6	17	-	-	10.306999
12	3	51.8	6	1812.0	1470.0	11.307251

Table 39 Long Sequence Waveform Trial#30 (Detected)

Waveform Name	Success Rate	Number of Trials
FCC Short Pulse Radar (Type 1)	100.0 %	30
FCC Short Pulse Radar (Type 2)	100.0 %	30
FCC Short Pulse Radar (Type 3)	100.0 %	30
FCC Short Pulse Radar (Type 4)	100.0 %	30
Long Sequence	93.3 %	30
FCC frequency hopping radar (Type 6)	90.0 %	30

Table 40 Summary of All Results for 20 MHz Bandwidth

Trial #	Pulses/Burst	Pulse Width (us)	PRI (us)	Detected ?	Fr (MHz) and level (dBm)	Hop seq.
0	18	1.0	1428.0	Yes	5530.0MHz, -64.0dBm	N/A
1	18	1.0	1428.0	Yes	5530.0MHz, -64.0dBm	N/A
2	18	1.0	1428.0	Yes	5530.0MHz, -64.0dBm	N/A
3	18	1.0	1428.0	Yes	5530.0MHz, -64.0dBm	N/A
4	18	1.0	1428.0	Yes	5530.0MHz, -64.0dBm	N/A
5	18	1.0	1428.0	Yes	5530.0MHz, -64.0dBm	N/A
6	18	1.0	1428.0	Yes	5530.0MHz, -64.0dBm	N/A
7	18	1.0	1428.0	Yes	5530.0MHz, -64.0dBm	N/A
8	18	1.0	1428.0	Yes	5530.0MHz, -64.0dBm	N/A
9	18	1.0	1428.0	Yes	5530.0MHz, -64.0dBm	N/A
10	18	1.0	1428.0	Yes	5530.0MHz, -64.0dBm	N/A
11	18	1.0	1428.0	Yes	5530.0MHz, -64.0dBm	N/A
12	18	1.0	1428.0	Yes	5530.0MHz, -64.0dBm	N/A
13	18	1.0	1428.0	Yes	5530.0MHz, -64.0dBm	N/A
14	18	1.0	1428.0	Yes	5530.0MHz, -64.0dBm	N/A

15	18	1.0	1428.0	Yes	5530.0MHz, -64.0dBm	N/A
16	18	1.0	1428.0	Yes	5530.0MHz, -64.0dBm	N/A
17	18	1.0	1428.0	Yes	5530.0MHz, -64.0dBm	N/A
18	18	1.0	1428.0	Yes	5530.0MHz, -64.0dBm	N/A
19	18	1.0	1428.0	Yes	5530.0MHz, -64.0dBm	N/A
20	18	1.0	1428.0	Yes	5530.0MHz, -64.0dBm	N/A
21	18	1.0	1428.0	Yes	5530.0MHz, -64.0dBm	N/A
22	18	1.0	1428.0	Yes	5530.0MHz, -64.0dBm	N/A
23	18	1.0	1428.0	Yes	5530.0MHz, -64.0dBm	N/A
24	18	1.0	1428.0	Yes	5530.0MHz, -64.0dBm	N/A
25	18	1.0	1428.0	Yes	5530.0MHz, -64.0dBm	N/A
26	18	1.0	1428.0	Yes	5320.0MHz, -64.0dBm	N/A
27	18	1.0	1428.0	Yes	5530.0MHz, -64.0dBm	N/A
28	18	1.0	1428.0	Yes	5530.0MHz, -64.0dBm	N/A
29	18	1.0	1428.0	Yes	5530.0MHz, -64.0dBm	N/A

Table 41 FCC Short Pulse Radar (Type 1) Test Results

Trial #	Pulses/Burst	Pulse Width (us)	PRI (us)	Detected ?	Fr (MHz) and level (dBm)	Hop seq.
0	27	2.0	162.0	Yes	5530.0MHz, -64.0dBm	N/A
1	25	2.9	198.0	Yes	5530.0MHz, -64.0dBm	N/A
2	24	4.3	226.0	Yes	5530.0MHz, -64.0dBm	N/A
3	28	4.0	226.0	Yes	5530.0MHz, -64.0dBm	N/A
4	27	4.0	185.0	Yes	5530.0MHz, -64.0dBm	N/A
5	24	4.0	193.0	Yes	5530.0MHz, -64.0dBm	N/A

6	28	3.0	215.0	Yes	5530.0MHz, -64.0dBm	N/A
7	25	1.0	207.0	Yes	5530.0MHz, -64.0dBm	N/A
8	26	2.1	169.0	Yes	5530.0MHz, -64.0dBm	N/A
9	29	2.7	183.0	Yes	5530.0MHz, -64.0dBm	N/A
10	26	3.5	212.0	Yes	5530.0MHz, -64.0dBm	N/A
11	26	1.3	229.0	Yes	5530.0MHz, -64.0dBm	N/A
12	23	4.4	226.0	Yes	5530.0MHz, -64.0dBm	N/A
13	23	4.9	217.0	Yes	5530.0MHz, -64.0dBm	N/A
14	24	2.2	150.0	Yes	5530.0MHz, -64.0dBm	N/A
15	24	3.5	150.0	Yes	5530.0MHz, -64.0dBm	N/A
16	25	4.3	184.0	Yes	5530.0MHz, -64.0dBm	N/A
17	24	1.8	199.0	Yes	5530.0MHz, -64.0dBm	N/A
18	25	2.1	225.0	Yes	5530.0MHz, -64.0dBm	N/A
19	25	4.6	174.0	Yes	5530.0MHz, -64.0dBm	N/A
20	27	4.2	187.0	Yes	5530.0MHz, -64.0dBm	N/A
21	25	1.9	214.0	Yes	5530.0MHz, -64.0dBm	N/A
22	23	1.4	191.0	Yes	5530.0MHz, -64.0dBm	N/A
23	26	2.9	204.0	Yes	5530.0MHz, -64.0dBm	N/A
24	25	1.8	160.0	Yes	5530.0MHz, -64.0dBm	N/A
25	26	1.7	190.0	Yes	5530.0MHz, -64.0dBm	N/A
26	27	3.1	198.0	Yes	5530.0MHz, -64.0dBm	N/A
27	24	3.5	217.0	Yes	5530.0MHz, -64.0dBm	N/A
28	26	3.5	194.0	Yes	5530.0MHz, -64.0dBm	N/A
29	27	1.5	165.0	Yes	5530.0MHz,	N/A

					-64.0dBm	
--	--	--	--	--	----------	--

Table 42 FCC Short Pulse Radar (Type 2) Test Results

Trial #	Pulses/Burst	Pulse Width (us)	PRI (us)	Detected ?	Fr (MHz) and level (dBm)	Hop seq.
0	17	7.4	456.0	Yes	5530.0MHz, -64.0dBm	N/A
1	18	8.1	377.0	Yes	5530.0MHz, -64.0dBm	N/A
2	17	7.0	486.0	Yes	5530.0MHz, -64.0dBm	N/A
3	17	8.6	489.0	Yes	5530.0MHz, -64.0dBm	N/A
4	17	6.2	453.0	Yes	5530.0MHz, -64.0dBm	N/A
5	18	9.9	328.0	Yes	5530.0MHz, -64.0dBm	N/A
6	16	8.5	399.0	Yes	5530.0MHz, -64.0dBm	N/A
7	18	8.7	250.0	Yes	5530.0MHz, -64.0dBm	N/A
8	16	9.8	494.0	Yes	5530.0MHz, -64.0dBm	N/A
9	17	8.1	457.0	Yes	5530.0MHz, -64.0dBm	N/A
10	18	8.4	339.0	Yes	5530.0MHz, -64.0dBm	N/A
11	17	6.6	354.0	Yes	5530.0MHz, -64.0dBm	N/A
12	17	7.1	305.0	Yes	5530.0MHz, -64.0dBm	N/A
13	17	7.7	218.0	Yes	5530.0MHz, -64.0dBm	N/A
14	17	7.6	339.0	Yes	5530.0MHz, -64.0dBm	N/A
15	16	8.3	350.0	Yes	5530.0MHz, -64.0dBm	N/A
16	17	9.1	429.0	Yes	5530.0MHz, -64.0dBm	N/A
17	18	8.8	292.0	Yes	5530.0MHz, -64.0dBm	N/A
18	16	9.6	490.0	Yes	5530.0MHz, -64.0dBm	N/A
19	17	7.2	299.0	Yes	5530.0MHz, -64.0dBm	N/A
20	16	9.3	416.0	Yes	5530.0MHz, -64.0dBm	N/A

					-64.0dBm	
21	17	7.7	448.0	Yes	5530.0MHz, -64.0dBm	N/A
22	16	6.0	433.0	Yes	5530.0MHz, -64.0dBm	N/A
23	18	7.1	265.0	Yes	5530.0MHz, -64.0dBm	N/A
24	17	9.5	322.0	Yes	5530.0MHz, -64.0dBm	N/A
25	16	7.7	383.0	Yes	5530.0MHz, -64.0dBm	N/A
26	18	8.7	360.0	Yes	5530.0MHz, -64.0dBm	N/A
27	17	8.6	380.0	Yes	5530.0MHz, -64.0dBm	N/A
28	17	6.8	359.0	Yes	5530.0MHz, -64.0dBm	N/A
29	17	6.0	245.0	Yes	5530.0MHz, -64.0dBm	N/A

Table 43 FCC Short Pulse Radar (Type 3) Test Results

Trial #	Pulses/Burst	Pulse Width (us)	PRI (us)	Detected ?	Fr (MHz) and level (dBm)	Hop seq.
0	13	16.9	218.0	Yes	5530.0MHz, -64.0dBm	N/A
1	13	13.4	307.0	Yes	5530.0MHz, -64.0dBm	N/A
2	13	13.0	343.0	Yes	5530.0MHz, -64.0dBm	N/A
3	15	13.1	326.0	Yes	5530.0MHz, -64.0dBm	N/A
4	13	14.2	371.0	Yes	5530.0MHz, -64.0dBm	N/A
5	14	12.6	419.0	Yes	5530.0MHz, -64.0dBm	N/A
6	15	13.1	341.0	Yes	5530.0MHz, -64.0dBm	N/A
7	14	19.5	318.0	Yes	5530.0MHz, -64.0dBm	N/A
8	13	18.2	493.0	Yes	5530.0MHz, -64.0dBm	N/A
9	13	16.2	249.0	Yes	5530.0MHz, -64.0dBm	N/A
10	13	15.4	448.0	Yes	5530.0MHz, -64.0dBm	N/A
11	15	11.1	434.0	Yes	5530.0MHz,	N/A

					-64.0dBm	
12	16	13.0	460.0	Yes	5530.0MHz, -64.0dBm	N/A
13	13	12.3	234.0	Yes	5530.0MHz, -64.0dBm	N/A
14	12	12.5	302.0	Yes	5530.0MHz, -64.0dBm	N/A
15	16	18.1	255.0	Yes	5530.0MHz, -64.0dBm	N/A
16	15	15.3	423.0	Yes	5530.0MHz, -64.0dBm	N/A
17	13	19.5	201.0	Yes	5530.0MHz, -64.0dBm	N/A
18	15	11.5	471.0	Yes	5530.0MHz, -64.0dBm	N/A
19	14	16.7	491.0	Yes	5530.0MHz, -64.0dBm	N/A
20	14	17.4	240.0	Yes	5530.0MHz, -64.0dBm	N/A
21	14	11.4	480.0	Yes	5530.0MHz, -64.0dBm	N/A
22	15	16.9	226.0	Yes	5530.0MHz, -64.0dBm	N/A
23	16	19.6	226.0	Yes	5530.0MHz, -64.0dBm	N/A
24	15	12.1	454.0	Yes	5530.0MHz, -64.0dBm	N/A
25	13	19.2	366.0	Yes	5530.0MHz, -64.0dBm	N/A
26	14	17.2	428.0	Yes	5530.0MHz, -64.0dBm	N/A
27	15	11.9	248.0	Yes	5530.0MHz, -64.0dBm	N/A
28	12	15.2	343.0	Yes	5530.0MHz, -64.0dBm	N/A
29	15	14.4	396.0	Yes	5530.0MHz, -64.0dBm	N/A

Table 44 FCC Short Pulse Radar (Type 4) Test Results

Long Sequence Trial	Result	Radar Frequency / Amplitude
Trial #1	Detected	5530.0MHz, -64.0dBm
Trial #2	Detected	5530.0MHz, -64.0dBm
Trial #3	Detected	5530.0MHz, -64.0dBm
Trial #4	Detected	5530.0MHz, -64.0dBm
Trial #5	Detected	5530.0MHz, -64.0dBm
Trial #6	Detected	5530.0MHz, -64.0dBm
Trial #7	Detected	5530.0MHz, -64.0dBm
Trial #8	Detected	5530.0MHz, -64.0dBm
Trial #9	Detected	5530.0MHz, -64.0dBm
Trial #10	Detected	5530.0MHz, -64.0dBm
Trial #11	Detected	5530.0MHz, -64.0dBm
Trial #12	Detected	5530.0MHz, -64.0dBm
Trial #13	Detected	5530.0MHz, -64.0dBm
Trial #14	Detected	5530.0MHz, -64.0dBm
Trial #15	NOT Detected	5530.0MHz, -64.0dBm
Trial #16	Detected	5530.0MHz, -64.0dBm
Trial #17	Detected	5530.0MHz, -64.0dBm
Trial #18	Detected	5530.0MHz, -64.0dBm
Trial #19	Detected	5530.0MHz, -64.0dBm
Trial #20	Detected	5530.0MHz, -64.0dBm
Trial #21	Detected	5530.0MHz, -64.0dBm
Trial #22	Detected	5530.0MHz, -64.0dBm
Trial #23	Detected	5530.0MHz,

		-64.0dBm
Trial #24	Detected	5530.0MHz, -64.0dBm
Trial #25	NOT Detected	5530.0MHz, -64.0dBm
Trial #26	Detected	5530.0MHz, -64.0dBm
Trial #27	Detected	5530.0MHz, -64.0dBm
Trial #28	Detected	5530.0MHz, -64.0dBm
Trial #29	Detected	5530.0MHz, -64.0dBm
Trial #30	Detected	5530.0MHz, -64.0dBm

Table 45 Long Sequence Waveform Summary

Burst #	# Pulses	Pulse Width (us)	Chirp (MHz)	Interval 1 to 2 (us)	Interval 2 to 3 (us)	Start time (us)
0	3	77.9	11	1819.0	1551.0	0.011185
1	2	86.1	6	1502.0	-	0.633439
2	3	56.2	20	1846.0	1936.0	1.233807
3	1	78.9	8	-	-	1.923322
4	1	75.2	14	-	-	2.545732
5	2	62.4	13	1927.0	-	3.189029
6	2	73.4	6	1423.0	-	3.800354
7	1	93.6	17	-	-	4.435397
8	3	80.2	19	1929.0	1083.0	4.863260
9	2	66.2	17	1590.0	-	5.469916
10	1	78.4	12	-	-	6.392957
11	2	75.6	14	1313.0	-	6.636103
12	2	96.3	6	1278.0	-	7.368348
13	1	80.1	10	-	-	7.844855
14	2	94.9	16	1280.0	-	8.770979
15	2	90.8	12	1922.0	-	9.204566
16	1	97.8	15	-	-	9.684033
17	2	51.1	13	1981.0	-	10.306020
18	3	52.0	13	1483.0	1106.0	11.218899
19	3	73.3	8	1461.0	1735.0	11.630476

Table 46 Long Sequence Waveform Trial#1 (Detected)

Burst #	# Pulses	Pulse Width (us)	Chirp (MHz)	Interval 1 to 2 (us)	Interval 2 to 3 (us)	Start time (us)
0	2	87.5	18	1013.0	-	0.135520
1	3	69.1	12	1445.0	1999.0	1.544451
2	2	64.1	10	1436.0	-	1.764333
3	3	94.9	10	1589.0	1141.0	2.755705
4	2	60.3	13	1809.0	-	3.510944
5	1	65.8	18	-	-	4.444006
6	3	51.8	9	1487.0	1505.0	5.387663
7	1	97.8	18	-	-	6.389950
8	1	83.3	17	-	-	6.956100
9	2	92.8	20	1225.0	-	8.296109
10	2	85.9	13	1173.0	-	8.719855
11	1	52.5	7	-	-	9.781731
12	2	63.7	19	1632.0	-	10.290779
13	1	67.7	5	-	-	11.849375

Table 47 Long Sequence Waveform Trial#2 (Detected)

Burst #	# Pulses	Pulse Width (us)	Chirp (MHz)	Interval 1 to 2 (us)	Interval 2 to 3 (us)	Start time (us)
0	2	68.1	11	1667.0	-	0.711373
1	1	69.9	6	-	-	1.296547
2	2	77.9	18	1460.0	-	1.717508
3	2	60.1	12	1980.0	-	3.158978
4	3	70.7	10	1286.0	1137.0	3.942661
5	1	89.0	8	-	-	4.305094
6	2	88.6	15	1588.0	-	5.444580
7	3	92.7	16	1079.0	1778.0	6.128673
8	2	54.9	20	1740.0	-	7.004589
9	2	90.1	19	1768.0	-	7.247069
10	1	66.9	7	-	-	8.058484
11	2	53.5	7	1919.0	-	9.144567
12	2	70.6	18	1487.0	-	9.643620
13	3	85.2	6	1293.0	1826.0	10.832658
14	3	96.8	17	1037.0	1491.0	11.495454

Table 48 Long Sequence Waveform Trial#3 (Detected)

Burst #	# Pulses	Pulse Width (us)	Chirp (MHz)	Interval 1 to 2 (us)	Interval 2 to 3 (us)	Start time (us)
0	2	53.8	19	1324.0	-	0.168280
1	1	83.6	13	-	-	1.470220
2	3	80.8	14	1968.0	1869.0	2.188973
3	1	87.3	13	-	-	2.607369
4	1	76.1	14	-	-	3.271610
5	1	65.0	8	-	-	4.638672
6	2	52.9	7	1381.0	-	4.855760
7	2	78.5	15	1647.0	-	5.708126
8	2	83.5	6	1037.0	-	6.889593
9	1	82.5	13	-	-	7.624625
10	2	90.5	14	1943.0	-	8.501141
11	3	56.4	13	1984.0	1655.0	8.965146
12	3	66.1	12	1632.0	1553.0	9.759941
13	3	85.2	11	1594.0	1724.0	10.747082
14	2	50.1	17	1548.0	-	11.589674

Table 49 Long Sequence Waveform Trial#4 (Detected)

Burst #	# Pulses	Pulse Width (us)	Chirp (MHz)	Interval 1 to 2 (us)	Interval 2 to 3 (us)	Start time (us)
0	1	61.2	13	-	-	0.093290
1	1	72.1	9	-	-	1.393331
2	2	82.6	6	1681.0	-	2.062415
3	1	61.4	11	-	-	2.735473
4	3	79.6	9	1894.0	1710.0	3.001455
5	3	96.5	6	1860.0	1802.0	4.335635
6	2	64.0	17	1505.0	-	4.592536
7	2	73.4	16	1141.0	-	5.499993
8	1	67.9	18	-	-	6.353984
9	3	59.3	19	1381.0	1317.0	7.095081
10	2	74.8	14	1048.0	-	7.741754
11	2	77.0	14	1805.0	-	8.632990
12	2	98.9	9	1678.0	-	9.317994
13	2	87.5	20	1554.0	-	10.036511
14	2	92.2	11	1790.0	-	10.843899
15	3	67.2	9	1307.0	1068.0	11.326987

Table 50 Long Sequence Waveform Trial#5 (Detected)

Burst #	# Pulses	Pulse Width (us)	Chirp (MHz)	Interval 1 to 2 (us)	Interval 2 to 3 (us)	Start time (us)
0	2	57.8	10	1503.0	-	0.610148
1	3	93.3	11	1239.0	1326.0	1.118053
2	2	85.7	18	1449.0	-	2.488721
3	2	50.0	9	1028.0	-	3.315144
4	2	58.2	6	1204.0	-	4.732140
5	3	97.6	10	1122.0	1366.0	5.958308
6	2	80.2	15	1947.0	-	6.237438
7	1	66.9	8	-	-	7.732535
8	3	98.8	16	1821.0	1887.0	8.625967
9	1	71.2	19	-	-	9.511600
10	2	51.5	18	1207.0	-	10.738840
11	3	96.3	6	1901.0	1130.0	11.589336

Table 51 Long Sequence Waveform Trial#6 (Detected)

Burst #	# Pulses	Pulse Width (us)	Chirp (MHz)	Interval 1 to 2 (us)	Interval 2 to 3 (us)	Start time (us)
0	2	60.6	5	1958.0	-	0.209855
1	2	53.5	14	1497.0	-	0.708408
2	2	65.1	11	1670.0	-	1.765748
3	3	76.8	16	1190.0	1720.0	2.235489
4	2	50.8	13	1351.0	-	3.266661
5	1	60.8	17	-	-	3.695717
6	2	59.8	20	1883.0	-	4.151378
7	2	73.3	10	1798.0	-	4.746212
8	2	95.2	8	1553.0	-	5.725021
9	3	64.9	13	1571.0	1299.0	6.195373
10	2	78.8	11	1344.0	-	7.200324
11	2	66.8	15	1253.0	-	7.808202
12	3	60.6	10	1435.0	1864.0	8.426578
13	3	62.6	7	1228.0	1251.0	8.899197
14	1	64.0	8	-	-	9.582472
15	2	90.2	15	1185.0	-	10.064251
16	2	61.9	10	1335.0	-	10.905317
17	3	95.5	19	1395.0	1732.0	11.534092

Table 52 Long Sequence Waveform Trial#7 (Detected)

Burst #	# Pulses	Pulse Width (us)	Chirp (MHz)	Interval 1 to 2 (us)	Interval 2 to 3 (us)	Start time (us)
0	2	61.9	15	1138.0	-	0.032635
1	1	58.6	18	-	-	2.195839
2	3	75.8	8	1044.0	1810.0	2.808050
3	2	99.7	10	1738.0	-	5.125394
4	2	86.6	7	1208.0	-	5.757120
5	2	60.7	13	1802.0	-	7.118886
6	2	82.1	11	1377.0	-	8.966016
7	3	89.8	12	1825.0	1582.0	9.365605
8	2	74.8	15	1464.0	-	11.912672

Table 53 Long Sequence Waveform Trial#8 (Detected)

Burst #	# Pulses	Pulse Width (us)	Chirp (MHz)	Interval 1 to 2 (us)	Interval 2 to 3 (us)	Start time (us)
0	3	89.9	10	1116.0	1553.0	0.750631
1	2	78.7	11	1153.0	-	1.122405
2	2	70.8	13	1296.0	-	2.161548
3	2	66.0	7	1682.0	-	2.991756
4	2	58.9	6	1383.0	-	4.314270
5	2	73.9	19	1111.0	-	5.318209
6	3	60.4	15	1019.0	1560.0	5.934675
7	3	59.0	10	1072.0	1644.0	7.210256
8	1	70.1	13	-	-	8.177079
9	3	59.9	15	1703.0	1858.0	8.596975
10	3	68.8	14	1303.0	1276.0	9.516062
11	3	65.4	17	1504.0	1383.0	10.449098
12	1	99.6	18	-	-	11.644609

Table 54 Long Sequence Waveform Trial#9 (Detected)

Burst #	# Pulses	Pulse Width (us)	Chirp (MHz)	Interval 1 to 2 (us)	Interval 2 to 3 (us)	Start time (us)
0	2	79.8	7	1753.0	-	0.119159
1	3	52.4	6	1864.0	1428.0	2.057036
2	3	62.2	20	1037.0	1472.0	3.407844
3	3	76.4	15	1057.0	1451.0	3.707542
4	2	95.7	14	1794.0	-	5.900123
5	2	52.3	16	1671.0	-	6.548827
6	3	83.2	18	1107.0	1435.0	8.024393
7	1	80.0	7	-	-	9.362826
8	3	70.0	15	1861.0	1946.0	10.308064
9	1	70.4	18	-	-	11.816775

Table 55 Long Sequence Waveform Trial#10 (Detected)

Burst #	# Pulses	Pulse Width (us)	Chirp (MHz)	Interval 1 to 2 (us)	Interval 2 to 3 (us)	Start time (us)
0	2	89.5	7	1648.0	-	0.366059
1	1	51.2	17	-	-	1.232878
2	1	61.6	8	-	-	1.720343
3	3	80.0	6	1147.0	1958.0	2.253122
4	2	82.3	14	1611.0	-	2.877160
5	2	51.7	12	1178.0	-	3.624552
6	3	54.9	10	1788.0	1920.0	4.788540
7	1	77.5	16	-	-	5.378360
8	2	63.1	10	1325.0	-	5.919550
9	3	58.7	17	1643.0	1191.0	6.725509
10	3	98.5	14	1000.0	1481.0	7.278369
11	3	70.8	5	1931.0	1334.0	8.246993
12	2	76.1	12	1760.0	-	8.512042
13	3	58.8	13	1474.0	1574.0	9.798945
14	2	83.1	19	1010.0	-	10.145887
15	2	96.9	7	1531.0	-	10.726345
16	1	52.3	16	-	-	11.553544

Table 56 Long Sequence Waveform Trial#11 (Detected)

Burst #	# Pulses	Pulse Width (us)	Chirp (MHz)	Interval 1 to 2 (us)	Interval 2 to 3 (us)	Start time (us)
0	3	57.0	7	1998.0	1075.0	0.562938
1	2	98.8	17	1639.0	-	1.334628
2	2	79.3	10	1319.0	-	2.084139
3	2	70.3	19	1319.0	-	3.230159
4	1	88.0	9	-	-	4.105052
5	1	83.1	6	-	-	4.840633
6	3	82.1	9	1978.0	1075.0	5.387004
7	2	83.8	10	1626.0	-	6.225061
8	2	69.2	9	1679.0	-	7.374028
9	3	67.0	9	1435.0	1267.0	8.259956
10	2	77.6	6	1202.0	-	8.748171
11	2	86.6	12	1137.0	-	9.687704
12	2	71.7	11	1314.0	-	10.584324
13	2	54.4	11	1630.0	-	11.325386

Table 57 Long Sequence Waveform Trial#12 (Detected)

Burst #	# Pulses	Pulse Width (us)	Chirp (MHz)	Interval 1 to 2 (us)	Interval 2 to 3 (us)	Start time (us)
0	1	87.1	12	-	-	1.272625
1	2	84.0	10	1784.0	-	1.409149
2	3	71.4	14	1709.0	1119.0	3.438259
3	2	83.8	8	1182.0	-	5.017984
4	2	87.8	11	1287.0	-	6.418521
5	1	86.0	13	-	-	7.352325
6	3	83.8	10	1764.0	1212.0	8.425665
7	1	50.7	19	-	-	10.194046
8	1	54.1	11	-	-	11.266766

Table 58 Long Sequence Waveform Trial#13 (Detected)

Burst #	# Pulses	Pulse Width (us)	Chirp (MHz)	Interval 1 to 2 (us)	Interval 2 to 3 (us)	Start time (us)
0	1	70.6	11	-	-	0.097331
1	1	53.5	6	-	-	1.475966
2	3	73.8	19	1788.0	1273.0	3.227814
3	2	96.1	15	1553.0	-	4.336635
4	3	98.8	9	1515.0	1164.0	4.592605
5	2	83.7	16	1554.0	-	6.239002
6	3	99.2	17	1353.0	1622.0	6.774595
7	3	91.5	16	1466.0	1553.0	7.835295
8	1	87.0	7	-	-	9.207429
9	2	51.1	7	1972.0	-	10.730918
10	1	52.4	15	-	-	11.974485

Table 59 Long Sequence Waveform Trial#14 (Detected)

Burst #	# Pulses	Pulse Width (us)	Chirp (MHz)	Interval 1 to 2 (us)	Interval 2 to 3 (us)	Start time (us)
0	2	73.1	15	1187.0	-	0.165514
1	3	94.5	12	1476.0	1948.0	1.388676
2	2	87.5	19	1009.0	-	3.554149
3	2	95.9	6	1581.0	-	5.263059
4	2	90.5	9	1748.0	-	5.596786
5	3	87.9	17	1863.0	1275.0	7.266451
6	2	97.9	10	1757.0	-	8.489708
7	2	93.4	8	1870.0	-	10.088526
8	2	87.5	15	1700.0	-	11.193126

Table 60 Long Sequence Waveform Trial#15 (NOT Detected **)**

Burst #	# Pulses	Pulse Width (us)	Chirp (MHz)	Interval 1 to 2 (us)	Interval 2 to 3 (us)	Start time (us)
0	2	92.4	20	1349.0	-	0.571809
1	1	61.3	16	-	-	0.978552
2	2	93.7	6	1215.0	-	1.927762
3	3	98.1	17	1940.0	1899.0	2.360481
4	3	89.4	15	1891.0	1548.0	2.975050
5	1	99.4	8	-	-	3.524216
6	3	57.8	13	1457.0	1989.0	4.188518
7	1	75.6	17	-	-	4.934857
8	3	91.6	15	1783.0	1913.0	5.422964
9	2	72.9	12	1625.0	-	6.176244
10	1	79.1	11	-	-	7.300581
11	1	65.8	17	-	-	7.598730
12	2	58.1	13	1372.0	-	8.503001
13	2	84.2	6	1265.0	-	8.990436
14	3	82.7	19	1125.0	1605.0	9.362487
15	2	83.9	11	1124.0	-	10.174845
16	2	84.3	6	1283.0	-	10.843882
17	2	74.5	9	1103.0	-	11.381212

Table 61 Long Sequence Waveform Trial#16 (Detected)

Burst #	# Pulses	Pulse Width (us)	Chirp (MHz)	Interval 1 to 2 (us)	Interval 2 to 3 (us)	Start time (us)
0	2	91.5	15	1087.0	-	0.697204
1	2	99.4	10	1866.0	-	0.877140
2	2	68.0	10	1861.0	-	1.780024
3	3	99.6	17	1250.0	1620.0	2.866624
4	1	55.7	5	-	-	4.057636
5	2	91.0	17	1903.0	-	4.334524
6	2	70.5	12	1967.0	-	5.693133
7	2	68.6	9	1589.0	-	6.774119
8	3	92.7	12	1361.0	1996.0	7.545429
9	3	98.8	7	1194.0	1387.0	7.995399
10	2	58.6	19	1834.0	-	9.205278
11	1	98.1	11	-	-	9.655791
12	3	90.8	9	1249.0	1706.0	10.625457
13	2	90.6	17	1409.0	-	11.268892

Table 62 Long Sequence Waveform Trial#17 (Detected)

Burst #	# Pulses	Pulse Width (us)	Chirp (MHz)	Interval 1 to 2 (us)	Interval 2 to 3 (us)	Start time (us)
0	2	99.6	20	1993.0	-	0.402226
1	1	72.4	9	-	-	0.719565
2	1	60.3	19	-	-	1.676987
3	1	91.3	7	-	-	2.005474
4	1	50.4	16	-	-	2.960606
5	3	98.8	14	1479.0	1163.0	3.553026
6	2	56.9	14	1923.0	-	4.002328
7	2	72.3	16	1316.0	-	4.544240
8	3	69.4	12	1307.0	1312.0	5.283330
9	2	62.6	19	1421.0	-	5.799830
10	2	82.2	19	1917.0	-	6.454543
11	2	95.9	11	1323.0	-	7.342369
12	2	54.4	7	1163.0	-	7.651637
13	3	96.4	13	1919.0	1451.0	8.288632
14	2	57.1	17	1070.0	-	9.233177
15	2	85.0	17	1017.0	-	9.482892
16	2	63.0	18	1752.0	-	10.503834
17	2	70.3	6	1841.0	-	11.234397
18	1	58.9	18	-	-	11.655689

Table 63 Long Sequence Waveform Trial#18 (Detected)

Burst #	# Pulses	Pulse Width (us)	Chirp (MHz)	Interval 1 to 2 (us)	Interval 2 to 3 (us)	Start time (us)
0	2	98.4	12	1113.0	-	0.560156
1	2	86.7	14	1397.0	-	1.936165
2	2	82.6	13	1428.0	-	2.825262
3	2	53.9	8	1904.0	-	3.590808
4	2	99.9	11	1546.0	-	4.284447
5	3	94.2	20	1754.0	1851.0	5.210358
6	2	91.4	10	1589.0	-	6.452400
7	2	82.8	15	1577.0	-	7.852189
8	2	89.5	9	1102.0	-	8.906533
9	1	55.4	7	-	-	9.611000
10	1	61.7	13	-	-	10.537565
11	2	67.6	8	1691.0	-	11.997671

Table 64 Long Sequence Waveform Trial#19 (Detected)

Burst #	# Pulses	Pulse Width (us)	Chirp (MHz)	Interval 1 to 2 (us)	Interval 2 to 3 (us)	Start time (us)
0	1	89.8	10	-	-	0.489849
1	2	74.3	17	1173.0	-	1.345979
2	2	81.7	10	1034.0	-	3.589238
3	2	74.2	16	1121.0	-	4.716054
4	1	61.9	14	-	-	5.763386
5	1	89.6	19	-	-	7.545313
6	2	80.3	13	1836.0	-	8.665041
7	2	60.8	6	1802.0	-	9.732429
8	1	84.0	20	-	-	10.977921

Table 65 Long Sequence Waveform Trial#20 (Detected)

Burst #	# Pulses	Pulse Width (us)	Chirp (MHz)	Interval 1 to 2 (us)	Interval 2 to 3 (us)	Start time (us)
0	2	73.6	12	1068.0	-	0.152092
1	2	78.1	12	1708.0	-	0.857746
2	1	64.9	7	-	-	1.862652
3	1	57.1	13	-	-	2.570558
4	3	76.0	12	1478.0	1356.0	3.358625
5	1	66.2	12	-	-	4.432580
6	2	88.4	6	1960.0	-	5.565171
7	1	88.6	14	-	-	5.753225
8	2	50.2	19	1070.0	-	6.810562
9	3	85.9	16	1139.0	1468.0	7.428029
10	1	73.0	9	-	-	8.689805
11	2	77.8	10	1815.0	-	9.225494
12	3	58.1	6	1072.0	1461.0	9.887723
13	3	79.6	8	1669.0	1893.0	10.728357
14	2	69.6	16	1259.0	-	11.524208

Table 66 Long Sequence Waveform Trial#21 (Detected)

Burst #	# Pulses	Pulse Width (us)	Chirp (MHz)	Interval 1 to 2 (us)	Interval 2 to 3 (us)	Start time (us)
0	3	82.3	14	1801.0	1603.0	0.019085
1	2	69.6	9	1540.0	-	0.718528
2	3	85.7	16	1942.0	1073.0	1.857450
3	2	91.5	8	1981.0	-	1.957917
4	2	76.1	9	1461.0	-	2.894430
5	1	53.2	13	-	-	3.591288
6	3	78.4	6	1704.0	1644.0	4.246327
7	1	74.1	5	-	-	4.800174
8	2	91.0	8	1042.0	-	5.593943
9	2	63.6	12	1946.0	-	6.024104
10	2	54.9	12	1443.0	-	6.654271
11	2	68.1	10	1622.0	-	7.283695
12	3	60.8	6	1803.0	1854.0	7.948920
13	2	60.6	17	1332.0	-	8.746740
14	1	85.9	11	-	-	9.459154
15	3	95.3	11	1025.0	1112.0	9.647709
16	2	63.2	16	1725.0	-	10.239037
17	2	75.8	12	1818.0	-	11.296289
18	1	61.9	12	-	-	11.876698

Table 67 Long Sequence Waveform Trial#22 (Detected)

Burst #	# Pulses	Pulse Width (us)	Chirp (MHz)	Interval 1 to 2 (us)	Interval 2 to 3 (us)	Start time (us)
0	2	75.4	10	1520.0	-	0.548753
1	2	89.2	15	1855.0	-	1.512718
2	3	56.2	7	1156.0	1561.0	2.518676
3	2	79.7	9	1964.0	-	3.125986
4	2	82.2	14	1178.0	-	4.223960
5	1	75.9	15	-	-	5.505170
6	2	98.1	16	1503.0	-	6.762595
7	2	74.2	15	1455.0	-	7.804424
8	1	94.6	16	-	-	8.519298
9	1	79.7	15	-	-	9.080136
10	2	77.6	11	1028.0	-	10.679569
11	1	61.8	12	-	-	11.098126

Table 68 Long Sequence Waveform Trial#23 (Detected)

Burst #	# Pulses	Pulse Width (us)	Chirp (MHz)	Interval 1 to 2 (us)	Interval 2 to 3 (us)	Start time (us)
0	2	90.8	14	1533.0	-	0.490387
1	2	63.7	8	1010.0	-	1.380087
2	3	58.7	17	1542.0	1569.0	3.187813
3	2	78.0	17	1621.0	-	4.721497
4	1	78.3	15	-	-	5.796535
5	2	67.8	19	1939.0	-	6.600264
6	1	75.4	17	-	-	7.559656
7	3	57.3	13	1025.0	1431.0	8.717629
8	1	98.2	10	-	-	10.275358
9	1	71.7	10	-	-	11.721626

Table 69 Long Sequence Waveform Trial#24 (Detected)

Burst #	# Pulses	Pulse Width (us)	Chirp (MHz)	Interval 1 to 2 (us)	Interval 2 to 3 (us)	Start time (us)
0	1	52.1	17	-	-	0.552636
1	2	67.7	14	1421.0	-	2.384428
2	2	80.8	20	1222.0	-	4.338661
3	1	81.5	17	-	-	5.054885
4	2	65.9	16	1563.0	-	6.793045
5	1	91.0	17	-	-	7.626174
6	2	91.0	19	1044.0	-	10.043354
7	2	64.5	11	1487.0	-	11.540382

Table 70 Long Sequence Waveform Trial#25 (NOT Detected **)**

Burst #	# Pulses	Pulse Width (us)	Chirp (MHz)	Interval 1 to 2 (us)	Interval 2 to 3 (us)	Start time (us)
0	2	57.7	10	1360.0	-	0.710163
1	1	95.5	12	-	-	1.228072
2	1	60.7	19	-	-	1.840267
3	1	55.6	12	-	-	2.700408
4	2	81.8	17	1473.0	-	3.517220
5	2	63.2	6	1721.0	-	4.431041
6	2	76.7	11	1381.0	-	5.838876
7	1	68.5	10	-	-	6.588091
8	3	64.5	16	1265.0	1726.0	7.026978
9	2	91.0	12	1818.0	-	8.492065
10	1	60.8	20	-	-	9.252345
11	2	52.2	15	1053.0	-	10.000231
12	2	79.9	19	1520.0	-	10.793246
13	1	91.4	6	-	-	11.419066

Table 71 Long Sequence Waveform Trial#26 (Detected)

Burst #	# Pulses	Pulse Width (us)	Chirp (MHz)	Interval 1 to 2 (us)	Interval 2 to 3 (us)	Start time (us)
0	2	51.0	9	1393.0	-	0.430869
1	2	72.8	19	1994.0	-	1.233428
2	1	51.4	20	-	-	1.649291
3	3	89.8	16	1660.0	1644.0	2.441951
4	2	91.9	19	1431.0	-	3.367194
5	1	51.1	11	-	-	4.165928
6	1	73.2	19	-	-	4.944780
7	3	56.0	6	1931.0	1849.0	5.663543
8	3	82.2	18	1832.0	1399.0	6.050541
9	2	69.8	17	1251.0	-	7.121232
10	2	83.2	8	1251.0	-	7.651304
11	3	76.4	5	1534.0	1167.0	8.677677
12	2	91.0	15	1904.0	-	9.458421
13	2	62.8	15	1755.0	-	10.015262
14	1	57.3	13	-	-	11.097737
15	2	79.9	15	1996.0	-	11.632029

Table 72 Long Sequence Waveform Trial#27 (Detected)

Burst #	# Pulses	Pulse Width (us)	Chirp (MHz)	Interval 1 to 2 (us)	Interval 2 to 3 (us)	Start time (us)
0	2	55.1	17	1809.0	-	0.761314
1	2	84.9	19	1301.0	-	1.706858
2	1	98.0	19	-	-	2.938223
3	1	57.7	17	-	-	3.725424
4	3	76.0	11	1273.0	1449.0	5.187299
5	2	97.4	15	1485.0	-	6.090731
6	2	78.9	16	1296.0	-	7.177566
7	1	61.3	18	-	-	8.353105
8	1	53.3	18	-	-	8.752838
9	1	71.3	10	-	-	10.164529
10	1	74.3	5	-	-	11.410619

Table 73 Long Sequence Waveform Trial#28 (Detected)

Burst #	# Pulses	Pulse Width (us)	Chirp (MHz)	Interval 1 to 2 (us)	Interval 2 to 3 (us)	Start time (us)
0	2	60.5	19	1794.0	-	1.300344
1	3	80.6	12	1398.0	1574.0	1.852766
2	1	98.6	7	-	-	4.488067
3	1	57.3	5	-	-	5.311693
4	2	84.0	19	1753.0	-	6.542303
5	1	94.4	20	-	-	8.613713
6	2	99.5	6	1167.0	-	9.684434
7	1	61.4	6	-	-	11.041591

Table 74 Long Sequence Waveform Trial#29 (Detected)

Burst #	# Pulses	Pulse Width (us)	Chirp (MHz)	Interval 1 to 2 (us)	Interval 2 to 3 (us)	Start time (us)
0	2	71.2	6	1461.0	-	0.436109
1	1	52.7	11	-	-	1.481232
2	1	74.8	11	-	-	1.875972
3	2	98.0	14	1200.0	-	2.434214
4	1	90.7	20	-	-	3.493828
5	2	88.0	10	1845.0	-	4.594247
6	2	90.7	15	1515.0	-	5.445291
7	2	69.9	14	1330.0	-	5.803556
8	2	79.8	6	1472.0	-	6.672268
9	3	68.2	9	1604.0	1250.0	7.712607
10	2	92.6	15	1386.0	-	8.543818
11	1	81.1	16	-	-	9.414439
12	1	81.6	7	-	-	9.713663
13	2	52.3	11	1170.0	-	10.952938
14	1	84.1	18	-	-	11.704961

Table 75 Long Sequence Waveform Trial#30 (Detected)

Trial #	Pulses/Burst	Pulse Width (us)	PRI (us)	Detected ?	Fr (MHz) and level (dBm)	Hop seq.
0	9	1.0	333.0	Yes	5515.0MHz, -64.0dBm	5566, 5497, 5343, 5560, 5286, 5606, 5618, 5437, 5708, 5277, 5578, 5641, 5438, 5392, 5647, 5678, 5481, 5516, 5447, 5549, 5332, 5420, 5433, 5662, 5496, 5356, 5488, 5252, 5632, 5639, 5454, 5453, 5530, 5681, 5295, 5525, 5635, 5523, 5613, 5261, 5472, 5536, 5451, 5340, 5700, 5394, 5409, 5355, 5408, 5642, 5296, 5719, 5533, 5679, 5665, 5347, 5412, 5378, 5465, 5570, 5588, 5598, 5468, 5405, 5563, 5285, 5552, 5489, 5505, 5337, 5384, 5664, 5414, 5470, 5362, 5705, 5310, 5425, 5400, 5336, 5254, 5399, 5430, 5716, 5289, 5519, 5305, 5547, 5359, 5657, 5683, 5445, 5576, 5422, 5293, 5395, 5318, 5321, 5638, 5587 (15 hits)
1	9	1.0	333.0	Yes	5516.0MHz, -64.0dBm	5714, 5369, 5309, 5457, 5411, 5349, 5641, 5661, 5634, 5259, 5283, 5681, 5413, 5255, 5398, 5463, 5518, 5319, 5362, 5356, 5265, 5315, 5650, 5503, 5544, 5672, 5353, 5678, 5594, 5600, 5444, 5697, 5331, 5443, 5566, 5523, 5613, 5574, 5501, 5391, 5289, 5502, 5712, 5713, 5270, 5370, 5408, 5635, 5440, 5554, 5665, 5687, 5421, 5327, 5304, 5448, 5363, 5301, 5264, 5510, 5339, 5344, 5397, 5565, 5653, 5667, 5605, 5275, 5552, 5666, 5675, 5347, 5723, 5334, 5531, 5373, 5269, 5505, 5538, 5312, 5355, 5579, 5656, 5376, 5498, 5629, 5595, 5556, 5642, 5462, 5593, 5632, 5637, 5530, 5494, 5400, 5528, 5403, 5638, 5422 (17 hits)
2	9	1.0	333.0	Yes	5517.0MHz,	5595, 5562, 5418, 5286, 5604,

					-64.0dBm	5565, 5374, 5612, 5256, 5389, 5522, 5677, 5355, 5541, 5489, 5721, 5569, 5707, 5425, 5723, 5539, 5578, 5632, 5502, 5642, 5404, 5660, 5586, 5668, 5518, 5662, 5520, 5499, 5514, 5614, 5646, 5298, 5687, 5606, 5331, 5263, 5505, 5450, 5368, 5392, 5566, 5560, 5360, 5402, 5663, 5325, 5251, 5449, 5714, 5708, 5395, 5521, 5507, 5472, 5679, 5347, 5478, 5670, 5400, 5587, 5278, 5674, 5653, 5432, 5710, 5335, 5361, 5610, 5383, 5513, 5387, 5328, 5330, 5671, 5698, 5469, 5551, 5431, 5643, 5320, 5528, 5268, 5427, 5592, 5318, 5515, 5441, 5366, 5508, 5388, 5307, 5550, 5463, 5609, 5304 (14 hits)
3	9	1.0	333.0	Yes	5518.0MHz, -64.0dBm	5384, 5582, 5426, 5637, 5663, 5388, 5618, 5307, 5672, 5602, 5323, 5479, 5503, 5369, 5322, 5530, 5570, 5528, 5399, 5272, 5342, 5276, 5716, 5408, 5470, 5321, 5467, 5383, 5720, 5450, 5704, 5430, 5326, 5407, 5456, 5584, 5381, 5622, 5561, 5343, 5434, 5468, 5282, 5422, 5387, 5441, 5267, 5705, 5425, 5278, 5413, 5714, 5475, 5640, 5609, 5568, 5476, 5629, 5270, 5352, 5266, 5554, 5291, 5577, 5438, 5419, 5703, 5274, 5711, 5361, 5675, 5339, 5489, 5694, 5498, 5420, 5540, 5660, 5490, 5548, 5396, 5289, 5395, 5501, 5605, 5309, 5699, 5590, 5552, 5458, 5424, 5677, 5596, 5614, 5659, 5362, 5531, 5544, 5390, 5542 (17 hits)
4	9	1.0	333.0	No	5519.0MHz, -64.0dBm	5350, 5719, 5257, 5715, 5338, 5707, 5517, 5638, 5545, 5503, 5684, 5629, 5469, 5379, 5686, 5694, 5658, 5273, 5586, 5457, 5402, 5281, 5282, 5359, 5303, 5507, 5268, 5675, 5647, 5583,

						5309, 5702, 5584, 5415, 5628, 5530, 5280, 5264, 5333, 5330, 5322, 5485, 5706, 5669, 5459, 5531, 5543, 5334, 5620, 5339, 5617, 5477, 5258, 5456, 5696, 5293, 5418, 5450, 5435, 5555, 5409, 5664, 5261, 5287, 5307, 5538, 5506, 5271, 5382, 5313, 5380, 5461, 5598, 5440, 5342, 5635, 5547, 5553, 5375, 5351, 5722, 5595, 5704, 5537, 5645, 5288, 5532, 5285, 5533, 5255, 5336, 5674, 5698, 5495, 5600, 5618, 5616, 5687, 5609, 5637 (22 hits)
5	9	1.0	333.0	Yes	5520.0MHz, -64.0dBm	5548, 5284, 5381, 5251, 5563, 5497, 5505, 5287, 5556, 5428, 5354, 5591, 5355, 5278, 5274, 5679, 5374, 5475, 5610, 5292, 5303, 5656, 5513, 5508, 5586, 5386, 5704, 5307, 5673, 5722, 5344, 5473, 5692, 5658, 5321, 5539, 5382, 5336, 5319, 5676, 5566, 5522, 5454, 5584, 5593, 5264, 5298, 5611, 5472, 5609, 5546, 5529, 5279, 5373, 5624, 5341, 5636, 5334, 5507, 5395, 5296, 5646, 5664, 5337, 5402, 5343, 5557, 5607, 5531, 5521, 5333, 5323, 5286, 5554, 5314, 5680, 5588, 5502, 5368, 5717, 5392, 5649, 5442, 5602, 5313, 5320, 5391, 5567, 5575, 5716, 5411, 5352, 5628, 5448, 5434, 5481, 5496, 5555, 5617, 5422 (19 hits)
6	9	1.0	333.0	Yes	5521.0MHz, -64.0dBm	5272, 5362, 5360, 5366, 5288, 5601, 5555, 5686, 5706, 5372, 5432, 5691, 5690, 5474, 5530, 5266, 5353, 5705, 5496, 5700, 5662, 5402, 5322, 5679, 5384, 5324, 5599, 5656, 5683, 5708, 5677, 5591, 5670, 5433, 5535, 5638, 5319, 5571, 5373, 5378, 5368, 5640, 5488, 5633, 5702, 5357, 5451, 5292, 5631, 5487, 5403, 5602, 5586, 5480, 5539,

						5461, 5380, 5653, 5408, 5550, 5579, 5469, 5442, 5508, 5498, 5575, 5712, 5459, 5580, 5676, 5391, 5342, 5648, 5275, 5438, 5263, 5395, 5482, 5725, 5381, 5639, 5414, 5382, 5445, 5537, 5704, 5512, 5394, 5533, 5258, 5632, 5386, 5390, 5545, 5552, 5416, 5501, 5447, 5434, 5343 (10 hits)
7	9	1.0	333.0	Yes	5522.0MHz, -64.0dBm	5470, 5593, 5327, 5526, 5502, 5345, 5702, 5346, 5299, 5723, 5412, 5672, 5611, 5418, 5369, 5655, 5706, 5360, 5381, 5667, 5659, 5643, 5387, 5306, 5510, 5452, 5325, 5691, 5374, 5555, 5391, 5357, 5627, 5586, 5681, 5608, 5638, 5506, 5321, 5516, 5265, 5428, 5693, 5533, 5633, 5320, 5426, 5342, 5293, 5538, 5701, 5328, 5568, 5443, 5661, 5559, 5475, 5519, 5450, 5324, 5267, 5471, 5656, 5716, 5531, 5467, 5508, 5551, 5348, 5288, 5455, 5498, 5719, 5592, 5274, 5594, 5356, 5712, 5714, 5557, 5491, 5670, 5289, 5602, 5541, 5296, 5657, 5497, 5422, 5632, 5433, 5353, 5261, 5571, 5724, 5642, 5282, 5413, 5435, 5617 (17 hits)
8	9	1.0	333.0	Yes	5523.0MHz, -64.0dBm	5338, 5678, 5580, 5460, 5639, 5403, 5531, 5685, 5384, 5288, 5301, 5315, 5464, 5579, 5291, 5584, 5398, 5322, 5467, 5724, 5581, 5316, 5587, 5354, 5261, 5679, 5697, 5279, 5705, 5484, 5330, 5273, 5257, 5308, 5379, 5530, 5363, 5295, 5491, 5607, 5608, 5396, 5445, 5514, 5708, 5680, 5435, 5274, 5566, 5508, 5518, 5488, 5648, 5650, 5307, 5677, 5392, 5688, 5574, 5621, 5504, 5298, 5366, 5449, 5562, 5507, 5265, 5666, 5378, 5647, 5522, 5343, 5606, 5407, 5277, 5290, 5628, 5436, 5691, 5596,

						5494, 5335, 5617, 5455, 5264, 5568, 5521, 5269, 5721, 5559, 5525, 5610, 5424, 5662, 5612, 5282, 5474, 5658, 5711, 5374 (22 hits)
9	9	1.0	333.0	Yes	5524.0MHz, -64.0dBm	5408, 5337, 5396, 5391, 5537, 5669, 5258, 5460, 5414, 5289, 5645, 5312, 5556, 5411, 5275, 5693, 5483, 5673, 5340, 5514, 5472, 5560, 5270, 5430, 5545, 5331, 5306, 5429, 5632, 5290, 5335, 5613, 5279, 5540, 5530, 5409, 5384, 5486, 5488, 5723, 5400, 5625, 5342, 5378, 5622, 5295, 5405, 5498, 5493, 5406, 5314, 5451, 5257, 5576, 5703, 5567, 5280, 5633, 5379, 5590, 5274, 5570, 5482, 5402, 5644, 5449, 5547, 5513, 5602, 5620, 5582, 5501, 5565, 5588, 5605, 5344, 5525, 5655, 5357, 5587, 5371, 5509, 5679, 5711, 5325, 5386, 5377, 5506, 5364, 5618, 5601, 5485, 5534, 5652, 5410, 5256, 5584, 5504, 5543, 5566 (16 hits)
10	9	1.0	333.0	Yes	5525.0MHz, -64.0dBm	5612, 5534, 5600, 5680, 5414, 5653, 5292, 5544, 5583, 5428, 5720, 5466, 5286, 5318, 5445, 5617, 5530, 5678, 5264, 5295, 5608, 5365, 5696, 5546, 5262, 5632, 5515, 5645, 5267, 5663, 5353, 5524, 5430, 5480, 5442, 5542, 5712, 5570, 5396, 5377, 5460, 5492, 5398, 5448, 5539, 5436, 5601, 5493, 5381, 5259, 5503, 5470, 5476, 5704, 5412, 5520, 5517, 5425, 5482, 5514, 5487, 5699, 5698, 5502, 5392, 5456, 5531, 5411, 5312, 5446, 5659, 5550, 5447, 5277, 5320, 5339, 5643, 5631, 5526, 5368, 5676, 5582, 5618, 5474, 5378, 5574, 5661, 5513, 5417, 5313, 5355, 5489, 5604, 5495, 5253, 5416, 5637, 5434, 5360, 5386 (14 hits)

11	9	1.0	333.0	Yes	5526.0MHz, -64.0dBm	5423, 5687, 5265, 5558, 5295, 5318, 5713, 5281, 5548, 5269, 5444, 5430, 5718, 5402, 5394, 5670, 5599, 5695, 5331, 5653, 5302, 5391, 5565, 5629, 5434, 5496, 5296, 5519, 5305, 5449, 5668, 5535, 5425, 5602, 5257, 5562, 5455, 5418, 5643, 5457, 5667, 5298, 5479, 5665, 5552, 5452, 5326, 5309, 5319, 5658, 5320, 5387, 5299, 5381, 5632, 5541, 5719, 5481, 5470, 5490, 5325, 5264, 5509, 5510, 5468, 5525, 5480, 5621, 5627, 5431, 5672, 5267, 5512, 5308, 5395, 5278, 5619, 5617, 5317, 5577, 5359, 5436, 5491, 5263, 5344, 5357, 5255, 5517, 5648, 5374, 5432, 5399, 5531, 5575, 5424, 5542, 5350, 5622, 5630, 5573 (23 hits)
12	9	1.0	333.0	Yes	5527.0MHz, -64.0dBm	5643, 5409, 5449, 5723, 5360, 5603, 5431, 5273, 5288, 5480, 5496, 5342, 5262, 5374, 5647, 5396, 5635, 5318, 5690, 5414, 5532, 5293, 5498, 5621, 5526, 5544, 5308, 5583, 5322, 5510, 5531, 5628, 5419, 5521, 5352, 5715, 5270, 5724, 5590, 5556, 5465, 5589, 5350, 5721, 5493, 5387, 5611, 5447, 5710, 5325, 5444, 5651, 5497, 5688, 5408, 5266, 5700, 5485, 5311, 5304, 5310, 5598, 5665, 5443, 5691, 5706, 5267, 5702, 5483, 5697, 5367, 5624, 5271, 5704, 5649, 5277, 5623, 5664, 5653, 5336, 5560, 5501, 5368, 5276, 5378, 5538, 5413, 5673, 5341, 5657, 5604, 5519, 5597, 5330, 5609, 5406, 5530, 5402, 5283, 5565 (20 hits)
13	9	1.0	333.0	Yes	5528.0MHz, -64.0dBm	5426, 5360, 5589, 5263, 5467, 5472, 5332, 5530, 5456, 5320, 5497, 5628, 5482, 5401, 5531, 5331, 5290, 5714, 5389, 5690, 5333, 5328, 5548, 5440, 5600,

						5370, 5550, 5666, 5553, 5380, 5266, 5503, 5534, 5458, 5307, 5374, 5619, 5390, 5527, 5715, 5315, 5570, 5642, 5311, 5547, 5342, 5381, 5506, 5473, 5477, 5336, 5379, 5326, 5285, 5691, 5398, 5716, 5313, 5308, 5554, 5347, 5590, 5598, 5450, 5451, 5274, 5519, 5350, 5382, 5453, 5502, 5638, 5447, 5474, 5423, 5622, 5257, 5592, 5460, 5444, 5345, 5376, 5498, 5654, 5704, 5484, 5667, 5475, 5696, 5269, 5279, 5579, 5526, 5651, 5349, 5552, 5710, 5454, 5404, 5693 (17 hits)
14	9	1.0	333.0	No	5529.0MHz, -64.0dBm	5693, 5681, 5489, 5571, 5443, 5513, 5680, 5568, 5718, 5603, 5614, 5311, 5709, 5594, 5368, 5517, 5407, 5719, 5330, 5276, 5321, 5319, 5520, 5468, 5497, 5569, 5666, 5689, 5563, 5533, 5437, 5538, 5363, 5302, 5694, 5362, 5381, 5705, 5539, 5286, 5298, 5573, 5682, 5378, 5530, 5482, 5429, 5258, 5317, 5367, 5460, 5426, 5392, 5679, 5447, 5678, 5351, 5545, 5592, 5552, 5275, 5570, 5280, 5548, 5267, 5546, 5559, 5336, 5534, 5405, 5567, 5639, 5373, 5607, 5575, 5399, 5623, 5529, 5688, 5503, 5587, 5645, 5418, 5646, 5668, 5629, 5558, 5704, 5458, 5305, 5416, 5354, 5450, 5288, 5655, 5349, 5281, 5425, 5284, 5462 (17 hits)
15	9	1.0	333.0	Yes	5530.0MHz, -64.0dBm	5707, 5366, 5659, 5507, 5462, 5624, 5309, 5289, 5369, 5630, 5626, 5610, 5599, 5354, 5717, 5554, 5328, 5487, 5393, 5646, 5568, 5607, 5287, 5415, 5317, 5414, 5541, 5329, 5539, 5615, 5296, 5712, 5666, 5299, 5606, 5345, 5252, 5661, 5454, 5633, 5304, 5422, 5722, 5668, 5498, 5254, 5556, 5532, 5519, 5674,

						5280, 5560, 5600, 5660, 5621, 5351, 5691, 5632, 5293, 5408, 5697, 5574, 5602, 5318, 5285, 5263, 5319, 5534, 5284, 5431, 5549, 5612, 5671, 5379, 5444, 5510, 5495, 5701, 5268, 5291, 5375, 5348, 5451, 5690, 5352, 5616, 5587, 5672, 5644, 5442, 5708, 5516, 5548, 5550, 5339, 5438, 5723, 5535, 5575, 5622 (20 hits)
16	9	1.0	333.0	Yes	5531.0MHz, -64.0dBm	5385, 5319, 5401, 5609, 5487, 5669, 5273, 5474, 5380, 5580, 5588, 5721, 5678, 5602, 5498, 5703, 5567, 5343, 5540, 5387, 5342, 5393, 5272, 5419, 5504, 5349, 5559, 5517, 5530, 5411, 5394, 5305, 5633, 5716, 5460, 5425, 5626, 5395, 5551, 5700, 5376, 5420, 5253, 5670, 5505, 5279, 5674, 5286, 5399, 5391, 5544, 5331, 5271, 5252, 5467, 5320, 5723, 5290, 5434, 5364, 5514, 5302, 5577, 5412, 5646, 5451, 5659, 5485, 5288, 5653, 5374, 5348, 5325, 5297, 5315, 5469, 5629, 5466, 5682, 5578, 5539, 5619, 5628, 5473, 5589, 5352, 5541, 5307, 5686, 5711, 5586, 5615, 5298, 5270, 5704, 5518, 5400, 5258, 5301, 5344 (22 hits)
17	9	1.0	333.0	Yes	5532.0MHz, -64.0dBm	5312, 5504, 5695, 5469, 5713, 5346, 5636, 5289, 5576, 5313, 5409, 5345, 5586, 5627, 5515, 5685, 5362, 5385, 5329, 5560, 5589, 5543, 5461, 5632, 5687, 5517, 5324, 5447, 5393, 5320, 5614, 5684, 5373, 5476, 5435, 5408, 5629, 5532, 5637, 5597, 5401, 5316, 5357, 5663, 5314, 5396, 5464, 5705, 5701, 5530, 5406, 5620, 5259, 5412, 5541, 5569, 5676, 5350, 5389, 5403, 5682, 5509, 5580, 5352, 5643, 5546, 5262, 5664, 5293, 5493, 5282, 5498, 5570, 5395, 5285,

						5640, 5665, 5472, 5431, 5573, 5564, 5444, 5661, 5484, 5402, 5270, 5266, 5691, 5297, 5360, 5298, 5318, 5483, 5672, 5679, 5422, 5448, 5348, 5463, 5647 (18 hits)
18	9	1.0	333.0	Yes	5533.0MHz, -64.0dBm	5584, 5307, 5418, 5627, 5319, 5409, 5298, 5356, 5544, 5474, 5698, 5304, 5282, 5483, 5575, 5486, 5361, 5542, 5596, 5697, 5459, 5573, 5277, 5314, 5491, 5297, 5654, 5701, 5327, 5478, 5629, 5707, 5662, 5553, 5633, 5706, 5419, 5269, 5265, 5454, 5299, 5724, 5267, 5623, 5405, 5528, 5402, 5545, 5661, 5433, 5620, 5320, 5540, 5558, 5579, 5569, 5471, 5487, 5668, 5370, 5520, 5531, 5275, 5529, 5323, 5444, 5504, 5254, 5672, 5615, 5547, 5601, 5293, 5272, 5488, 5406, 5420, 5258, 5494, 5549, 5518, 5510, 5318, 5336, 5445, 5274, 5664, 5505, 5502, 5657, 5524, 5428, 5527, 5343, 5576, 5315, 5442, 5465, 5600, 5287 (24 hits)
19	9	1.0	333.0	No	5534.0MHz, -64.0dBm	5709, 5445, 5290, 5668, 5284, 5441, 5557, 5615, 5530, 5465, 5707, 5612, 5566, 5534, 5629, 5626, 5676, 5630, 5691, 5533, 5402, 5585, 5550, 5461, 5530, 5531, 5486, 5686, 5554, 5718, 5280, 5418, 5571, 5312, 5643, 5520, 5263, 5622, 5503, 5599, 5667, 5289, 5472, 5270, 5466, 5650, 5586, 5323, 5343, 5304, 5638, 5296, 5336, 5286, 5297, 5493, 5381, 5354, 5273, 5502, 5547, 5471, 5459, 5335, 5410, 5315, 5504, 5669, 5271, 5469, 5321, 5695, 5251, 5663, 5565, 5540, 5331, 5374, 5293, 5363, 5646, 5479, 5613, 5581, 5261, 5329, 5724, 5254, 5276, 5356, 5600, 5597, 5411, 5496, 5617, 5361, 5470, 5645, 5417, 5642

						(23 hits)
20	9	1.0	333.0	Yes	5535.0MHz, -64.0dBm	5714, 5559, 5473, 5453, 5329, 5538, 5288, 5698, 5466, 5320, 5632, 5549, 5340, 5643, 5578, 5388, 5433, 5484, 5721, 5648, 5303, 5283, 5585, 5496, 5481, 5602, 5676, 5704, 5681, 5452, 5508, 5625, 5425, 5666, 5646, 5617, 5495, 5308, 5296, 5341, 5273, 5619, 5256, 5470, 5552, 5644, 5530, 5461, 5384, 5708, 5307, 5445, 5298, 5326, 5253, 5411, 5546, 5381, 5540, 5319, 5534, 5663, 5369, 5593, 5637, 5664, 5635, 5589, 5432, 5668, 5352, 5327, 5613, 5505, 5292, 5566, 5594, 5355, 5536, 5405, 5579, 5304, 5375, 5365, 5459, 5443, 5353, 5639, 5276, 5590, 5356, 5680, 5535, 5486, 5660, 5513, 5265, 5607, 5332, 5382 (19 hits)
21	9	1.0	333.0	Yes	5536.0MHz, -64.0dBm	5444, 5576, 5564, 5251, 5355, 5269, 5375, 5561, 5612, 5359, 5720, 5683, 5574, 5651, 5266, 5643, 5672, 5665, 5660, 5662, 5562, 5516, 5700, 5695, 5353, 5440, 5326, 5469, 5518, 5623, 5477, 5253, 5724, 5404, 5418, 5295, 5530, 5380, 5715, 5584, 5501, 5461, 5639, 5476, 5559, 5607, 5345, 5297, 5265, 5392, 5328, 5489, 5491, 5659, 5385, 5699, 5689, 5618, 5467, 5431, 5542, 5517, 5485, 5393, 5305, 5603, 5436, 5565, 5250, 5453, 5675, 5339, 5536, 5356, 5270, 5472, 5513, 5336, 5631, 5642, 5524, 5710, 5480, 5492, 5420, 5439, 5530, 5334, 5563, 5414, 5599, 5451, 5322, 5429, 5709, 5614, 5374, 5483, 5681, 5696 (15 hits)
22	9	1.0	333.0	Yes	5537.0MHz, -64.0dBm	5662, 5576, 5253, 5553, 5580, 5691, 5524, 5492, 5552, 5437, 5390, 5351, 5565, 5673, 5510, 5334, 5352, 5469, 5476, 5594,

						5522, 5545, 5271, 5544, 5310, 5535, 5499, 5345, 5703, 5328, 5491, 5411, 5575, 5686, 5463, 5701, 5462, 5573, 5714, 5330, 5605, 5601, 5626, 5490, 5682, 5461, 5713, 5652, 5559, 5667, 5692, 5650, 5563, 5265, 5307, 5550, 5708, 5359, 5431, 5660, 5309, 5617, 5280, 5723, 5270, 5273, 5543, 5558, 5627, 5649, 5287, 5530, 5296, 5609, 5349, 5632, 5459, 5583, 5397, 5712, 5479, 5341, 5721, 5604, 5340, 5529, 5308, 5339, 5538, 5586, 5671, 5725, 5456, 5622, 5645, 5678, 5333, 5342, 5629, 5408 (14 hits)
23	9	1.0	333.0	Yes	5538.0MHz, -64.0dBm	5328, 5432, 5584, 5348, 5559, 5399, 5487, 5524, 5530, 5372, 5342, 5366, 5258, 5455, 5278, 5326, 5629, 5646, 5327, 5719, 5623, 5690, 5392, 5405, 5441, 5563, 5578, 5597, 5447, 5528, 5516, 5382, 5384, 5594, 5557, 5699, 5466, 5299, 5335, 5718, 5288, 5714, 5530, 5683, 5517, 5679, 5677, 5330, 5264, 5581, 5412, 5256, 5560, 5571, 5458, 5357, 5417, 5569, 5445, 5292, 5435, 5287, 5685, 5352, 5341, 5459, 5531, 5331, 5542, 5403, 5265, 5296, 5439, 5297, 5367, 5547, 5490, 5282, 5463, 5709, 5442, 5691, 5608, 5283, 5457, 5711, 5636, 5626, 5575, 5409, 5672, 5561, 5354, 5370, 5510, 5360, 5715, 5402, 5400, 5431 (18 hits)
24	9	1.0	333.0	Yes	5539.0MHz, -64.0dBm	5621, 5265, 5546, 5374, 5272, 5686, 5464, 5393, 5433, 5385, 5688, 5527, 5336, 5610, 5680, 5386, 5445, 5315, 5288, 5332, 5470, 5638, 5639, 5452, 5263, 5378, 5342, 5649, 5328, 5541, 5428, 5608, 5717, 5660, 5366, 5577, 5318, 5502, 5421, 5446, 5481, 5348, 5558, 5329, 5682,

						5645, 5563, 5697, 5467, 5316, 5611, 5525, 5675, 5424, 5448, 5275, 5271, 5554, 5439, 5383, 5397, 5321, 5373, 5580, 5627, 5302, 5395, 5724, 5714, 5531, 5570, 5479, 5281, 5475, 5334, 5555, 5647, 5569, 5704, 5553, 5354, 5673, 5567, 5651, 5551, 5505, 5705, 5368, 5523, 5364, 5641, 5510, 5537, 5411, 5495, 5358, 5699, 5268, 5477, 5545 (15 hits)
25	9	1.0	333.0	Yes	5540.0MHz, -64.0dBm	5625, 5315, 5277, 5647, 5598, 5646, 5310, 5279, 5472, 5422, 5648, 5719, 5311, 5398, 5320, 5475, 5611, 5378, 5261, 5271, 5329, 5581, 5452, 5367, 5706, 5364, 5280, 5683, 5522, 5357, 5478, 5404, 5590, 5270, 5656, 5447, 5258, 5620, 5716, 5365, 5507, 5331, 5506, 5582, 5403, 5544, 5387, 5610, 5550, 5281, 5680, 5435, 5596, 5723, 5441, 5637, 5291, 5534, 5476, 5339, 5451, 5599, 5299, 5461, 5724, 5635, 5273, 5382, 5360, 5474, 5538, 5356, 5253, 5383, 5347, 5508, 5354, 5613, 5460, 5691, 5440, 5700, 5390, 5654, 5397, 5407, 5415, 5302, 5266, 5684, 5504, 5439, 5327, 5520, 5362, 5614, 5425, 5294, 5676, 5399 (21 hits)
26	9	1.0	333.0	Yes	5541.0MHz, -64.0dBm	5278, 5304, 5713, 5683, 5281, 5447, 5612, 5453, 5474, 5678, 5387, 5425, 5412, 5355, 5282, 5502, 5556, 5651, 5471, 5578, 5523, 5253, 5702, 5671, 5606, 5496, 5618, 5575, 5443, 5266, 5676, 5277, 5534, 5491, 5255, 5536, 5604, 5351, 5470, 5695, 5582, 5688, 5538, 5707, 5662, 5524, 5601, 5349, 5445, 5323, 5576, 5682, 5610, 5625, 5483, 5476, 5716, 5620, 5654, 5609, 5656, 5473, 5611, 5614, 5547, 5511, 5559, 5344, 5535, 5627,

						5404, 5513, 5477, 5680, 5454, 5689, 5664, 5494, 5522, 5395, 5410, 5314, 5433, 5698, 5273, 5595, 5382, 5720, 5271, 5274, 5532, 5489, 5697, 5706, 5499, 5409, 5497, 5632, 5252, 5461 (14 hits)
27	9	1.0	333.0	Yes	5542.0MHz, -64.0dBm	5601, 5312, 5262, 5369, 5405, 5456, 5588, 5399, 5303, 5343, 5690, 5294, 5449, 5610, 5374, 5660, 5713, 5495, 5494, 5688, 5439, 5531, 5529, 5411, 5484, 5550, 5468, 5425, 5418, 5315, 5718, 5558, 5698, 5643, 5377, 5278, 5637, 5432, 5609, 5363, 5344, 5434, 5365, 5552, 5392, 5285, 5510, 5515, 5313, 5353, 5544, 5446, 5255, 5678, 5493, 5345, 5567, 5589, 5530, 5355, 5389, 5570, 5442, 5587, 5307, 5443, 5647, 5384, 5458, 5603, 5390, 5536, 5357, 5684, 5502, 5672, 5296, 5681, 5720, 5530, 5283, 5416, 5376, 5340, 5503, 5463, 5306, 5302, 5421, 5682, 5624, 5526, 5556, 5642, 5264, 5326, 5652, 5664, 5396, 5563 (17 hits)
28	9	1.0	333.0	Yes	5543.0MHz, -64.0dBm	5255, 5375, 5420, 5327, 5597, 5498, 5626, 5689, 5569, 5355, 5576, 5465, 5266, 5481, 5334, 5632, 5663, 5649, 5557, 5395, 5724, 5639, 5484, 5310, 5579, 5694, 5507, 5559, 5675, 5699, 5686, 5543, 5723, 5532, 5408, 5635, 5636, 5432, 5544, 5325, 5292, 5358, 5275, 5427, 5528, 5309, 5388, 5553, 5650, 5678, 5637, 5265, 5679, 5382, 5383, 5477, 5278, 5530, 5672, 5673, 5687, 5608, 5287, 5443, 5604, 5489, 5290, 5660, 5568, 5530, 5702, 5644, 5720, 5469, 5360, 5488, 5346, 5501, 5657, 5508, 5485, 5495, 5448, 5603, 5713, 5538, 5348, 5376, 5618, 5621, 5582, 5518, 5438, 5616, 5426,

						5550, 5462, 5497, 5386, 5353 (13 hits)
29	9	1.0	333.0	Yes	5544.0MHz, -64.0dBm	5339, 5600, 5691, 5609, 5635, 5643, 5538, 5434, 5307, 5551, 5653, 5535, 5466, 5318, 5667, 5530, 5365, 5479, 5405, 5444, 5701, 5631, 5636, 5301, 5596, 5426, 5708, 5503, 5590, 5506, 5544, 5690, 5632, 5309, 5350, 5359, 5397, 5583, 5658, 5589, 5315, 5290, 5669, 5680, 5577, 5401, 5332, 5564, 5305, 5459, 5378, 5488, 5302, 5279, 5560, 5369, 5692, 5649, 5316, 5297, 5399, 5712, 5445, 5489, 5547, 5574, 5398, 5268, 5287, 5707, 5406, 5435, 5263, 5624, 5627, 5595, 5629, 5256, 5641, 5511, 5638, 5676, 5458, 5392, 5441, 5671, 5648, 5285, 5437, 5288, 5713, 5683, 5275, 5370, 5449, 5541, 5587, 5465, 5613, 5563 (18 hits)

Table 76 FCC frequency hopping radar (Type 6) Test Results

Waveform Name	Success Rate	Number of Trials
FCC Short Pulse Radar (Type 1)	70 %	30
FCC Short Pulse Radar (Type 2)	90.0 %	30
FCC Short Pulse Radar (Type 3)	86.7 %	30
FCC Short Pulse Radar (Type 4)	83.3 %	30
FCC frequency hopping radar (Type 6)	100.0 %	30
Long Sequence	96.7 %	30

Table 77 Summary of All Results for 40 MHz Bandwidth

Trial #	Pulses/Burst	Pulse Width (us)	PRI (us)	Detected ?	Fr (MHz) and level (dBm)	Hop seq.
0	18	1.0	1428.0	Yes	5530.0MHz, -64.0dBm	N/A
1	18	1.0	1428.0	Yes	5530.0MHz, -64.0dBm	N/A
2	18	1.0	1428.0	No	5530.0MHz, -64.0dBm	N/A
3	18	1.0	1428.0	Yes	5530.0MHz, -64.0dBm	N/A
4	18	1.0	1428.0	Yes	5530.0MHz, -64.0dBm	N/A
5	18	1.0	1428.0	Yes	5530.0MHz, -64.0dBm	N/A
6	18	1.0	1428.0	No	5530.0MHz, -64.0dBm	N/A
7	18	1.0	1428.0	Yes	5530.0MHz, -64.0dBm	N/A
8	18	1.0	1428.0	Yes	5530.0MHz, -64.0dBm	N/A
9	18	1.0	1428.0	No	5530.0MHz, -64.0dBm	N/A
10	18	1.0	1428.0	Yes	5530.0MHz, -64.0dBm	N/A
11	18	1.0	1428.0	Yes	5530.0MHz, -64.0dBm	N/A
12	18	1.0	1428.0	Yes	5530.0MHz, -64.0dBm	N/A
13	18	1.0	1428.0	Yes	5530.0MHz, -64.0dBm	N/A
14	18	1.0	1428.0	No	5530.0MHz, -64.0dBm	N/A

					-64.0dBm	
15	18	1.0	1428.0	Yes	5530.0MHz, -64.0dBm	N/A
16	18	1.0	1428.0	Yes	5530.0MHz, -64.0dBm	N/A
17	18	1.0	1428.0	No	5530.0MHz, -64.0dBm	N/A
18	18	1.0	1428.0	Yes	5530.0MHz, -64.0dBm	N/A
19	18	1.0	1428.0	Yes	5530.0MHz, -64.0dBm	N/A
20	18	1.0	1428.0	Yes	5530.0MHz, -64.0dBm	N/A
21	18	1.0	1428.0	No	5530.0MHz, -64.0dBm	N/A
22	18	1.0	1428.0	Yes	5530.0MHz, -64.0dBm	N/A
23	18	1.0	1428.0	No	5530.0MHz, -64.0dBm	N/A
24	18	1.0	1428.0	Yes	5530.0MHz, -64.0dBm	N/A
25	18	1.0	1428.0	No	5530.0MHz, -64.0dBm	N/A
26	18	1.0	1428.0	Yes	5530.0MHz, -64.0dBm	N/A
27	18	1.0	1428.0	Yes	5530.0MHz, -64.0dBm	N/A
28	18	1.0	1428.0	No	5530.0MHz, -64.0dBm	N/A
29	18	1.0	1428.0	Yes	5530.0MHz, -64.0dBm	N/A

Table 78 FCC Short Pulse Radar (Type 1) Test Results

Trial #	Pulses/Burst	Pulse Width (us)	PRI (us)	Detected ?	Fr (MHz) and level (dBm)	Hop seq.
0	23	3.8	224.0	Yes	5530.0MHz, -64.0dBm	N/A
1	23	4.4	216.0	No	5530.0MHz, -64.0dBm	N/A
2	26	2.4	227.0	Yes	5530.0MHz, -64.0dBm	N/A
3	25	2.9	226.0	Yes	5530.0MHz, -64.0dBm	N/A
4	26	2.6	183.0	Yes	5530.0MHz, -64.0dBm	N/A
5	26	1.7	176.0	Yes	5530.0MHz,	N/A

					-64.0dBm	
6	26	3.4	213.0	Yes	5530.0MHz, -64.0dBm	N/A
7	24	4.1	227.0	Yes	5530.0MHz, -64.0dBm	N/A
8	26	4.7	164.0	No	5530.0MHz, -64.0dBm	N/A
9	28	4.8	174.0	Yes	5530.0MHz, -64.0dBm	N/A
10	27	2.1	174.0	Yes	5530.0MHz, -64.0dBm	N/A
11	28	3.3	157.0	Yes	5530.0MHz, -64.0dBm	N/A
12	24	2.8	225.0	Yes	5530.0MHz, -64.0dBm	N/A
13	28	4.2	220.0	Yes	5530.0MHz, -64.0dBm	N/A
14	25	2.8	204.0	Yes	5530.0MHz, -64.0dBm	N/A
15	29	4.9	168.0	Yes	5530.0MHz, -64.0dBm	N/A
16	27	4.2	222.0	Yes	5530.0MHz, -64.0dBm	N/A
17	23	3.0	162.0	Yes	5530.0MHz, -64.0dBm	N/A
18	26	4.0	191.0	Yes	5530.0MHz, -64.0dBm	N/A
19	27	4.8	208.0	Yes	5530.0MHz, -64.0dBm	N/A
20	26	3.6	182.0	Yes	5530.0MHz, -64.0dBm	N/A
21	25	4.7	186.0	Yes	5530.0MHz, -64.0dBm	N/A
22	25	3.3	215.0	Yes	5530.0MHz, -64.0dBm	N/A
23	26	3.3	190.0	Yes	5530.0MHz, -64.0dBm	N/A
24	29	3.1	219.0	Yes	5530.0MHz, -64.0dBm	N/A
25	23	1.7	175.0	No	5530.0MHz, -64.0dBm	N/A
26	25	2.5	177.0	Yes	5530.0MHz, -64.0dBm	N/A
27	26	1.2	194.0	Yes	5530.0MHz, -64.0dBm	N/A
28	29	2.8	229.0	Yes	5530.0MHz, -64.0dBm	N/A

29	28	2.4	156.0	Yes	5530.0MHz, -64.0dBm	N/A
----	----	-----	-------	-----	------------------------	-----

Table 79 FCC Short Pulse Radar (Type 2) Test Results

Trial #	Pulses/Burst	Pulse Width (us)	PRI (us)	Detected ?	Fr (MHz) and level (dBm)	Hop seq.
0	17	9.8	228.0	Yes	5530.0MHz, -64.0dBm	N/A
1	16	9.4	434.0	No	5530.0MHz, -64.0dBm	N/A
2	17	9.9	408.0	Yes	5530.0MHz, -64.0dBm	N/A
3	17	6.8	290.0	Yes	5530.0MHz, -64.0dBm	N/A
4	18	9.3	271.0	Yes	5530.0MHz, -64.0dBm	N/A
5	17	9.3	265.0	Yes	5530.0MHz, -64.0dBm	N/A
6	17	8.8	379.0	Yes	5530.0MHz, -64.0dBm	N/A
7	16	7.7	309.0	Yes	5530.0MHz, -64.0dBm	N/A
8	17	6.8	280.0	Yes	5530.0MHz, -64.0dBm	N/A
9	16	7.4	271.0	Yes	5530.0MHz, -64.0dBm	N/A
10	17	10.0	334.0	Yes	5530.0MHz, -64.0dBm	N/A
11	18	7.0	244.0	Yes	5530.0MHz, -64.0dBm	N/A
12	17	8.8	225.0	Yes	5530.0MHz, -64.0dBm	N/A
13	18	9.7	307.0	No	5530.0MHz, -64.0dBm	N/A
14	17	8.0	440.0	Yes	5530.0MHz, -64.0dBm	N/A
15	17	9.6	426.0	Yes	5530.0MHz, -64.0dBm	N/A
16	17	9.4	414.0	Yes	5530.0MHz, -64.0dBm	N/A
17	16	6.4	472.0	Yes	5530.0MHz, -64.0dBm	N/A
18	17	9.2	237.0	Yes	5530.0MHz, -64.0dBm	N/A
19	17	9.0	330.0	Yes	5530.0MHz, -64.0dBm	N/A

20	17	6.4	472.0	Yes	5530.0MHz, -64.0dBm	N/A
21	18	6.1	275.0	Yes	5530.0MHz, -64.0dBm	N/A
22	17	9.8	408.0	Yes	5530.0MHz, -64.0dBm	N/A
23	18	8.5	464.0	Yes	5530.0MHz, -64.0dBm	N/A
24	16	9.6	229.0	Yes	5530.0MHz, -64.0dBm	N/A
25	17	7.7	427.0	Yes	5530.0MHz, -64.0dBm	N/A
26	16	9.5	478.0	No	5530.0MHz, -64.0dBm	N/A
27	17	6.1	232.0	No	5530.0MHz, -64.0dBm	N/A
28	17	6.0	422.0	Yes	5530.0MHz, -64.0dBm	N/A
29	17	8.9	413.0	Yes	5530.0MHz, -64.0dBm	N/A

Table 80 FCC Short Pulse Radar (Type 3) Test Results

Trial #	Pulses/Burst	Pulse Width (us)	PRI (us)	Detected ?	Fr (MHz) and level (dBm)	Hop seq.
0	14	14.0	452.0	Yes	5530.0MHz, -64.0dBm	N/A
1	13	11.7	461.0	Yes	5530.0MHz, -64.0dBm	N/A
2	12	12.5	221.0	Yes	5530.0MHz, -64.0dBm	N/A
3	15	19.8	319.0	Yes	5530.0MHz, -64.0dBm	N/A
4	12	11.4	294.0	Yes	5530.0MHz, -64.0dBm	N/A
5	14	11.9	213.0	Yes	5530.0MHz, -64.0dBm	N/A
6	15	14.4	223.0	No	5530.0MHz, -64.0dBm	N/A
7	14	16.8	488.0	No	5530.0MHz, -64.0dBm	N/A
8	15	19.9	211.0	Yes	5530.0MHz, -64.0dBm	N/A
9	16	18.4	246.0	Yes	5530.0MHz, -64.0dBm	N/A
10	13	19.2	431.0	Yes	5530.0MHz, -64.0dBm	N/A

11	14	14.5	370.0	No	5530.0MHz, -64.0dBm	N/A
12	13	11.7	406.0	Yes	5530.0MHz, -64.0dBm	N/A
13	15	12.0	443.0	Yes	5530.0MHz, -64.0dBm	N/A
14	12	16.0	266.0	Yes	5530.0MHz, -64.0dBm	N/A
15	13	11.2	334.0	Yes	5530.0MHz, -64.0dBm	N/A
16	14	11.7	333.0	Yes	5530.0MHz, -64.0dBm	N/A
17	15	14.1	239.0	Yes	5530.0MHz, -64.0dBm	N/A
18	16	12.7	265.0	Yes	5530.0MHz, -64.0dBm	N/A
19	13	16.0	483.0	Yes	5530.0MHz, -64.0dBm	N/A
20	15	19.7	319.0	Yes	5530.0MHz, -64.0dBm	N/A
21	14	17.9	369.0	Yes	5530.0MHz, -64.0dBm	N/A
22	13	12.1	469.0	Yes	5530.0MHz, -64.0dBm	N/A
23	16	18.0	454.0	Yes	5530.0MHz, -64.0dBm	N/A
24	16	19.0	208.0	Yes	5530.0MHz, -64.0dBm	N/A
25	16	16.3	373.0	Yes	5530.0MHz, -64.0dBm	N/A
26	13	14.6	302.0	Yes	5530.0MHz, -64.0dBm	N/A
27	13	18.8	354.0	No	5530.0MHz, -64.0dBm	N/A
28	13	11.3	388.0	Yes	5530.0MHz, -64.0dBm	N/A
29	12	15.3	386.0	No	5530.0MHz, -64.0dBm	N/A

Table 81 FCC Short Pulse Radar (Type 4) Test Results

Trial #	Pulses/Burst	Pulse Width (us)	PRI (us)	Detected ?	Fr (MHz) and level (dBm)	Hop seq.
0	9	1.0	333.0	Yes	5515.0MHz, -64.0dBm	5364, 5702, 5441, 5357, 5717, 5616, 5567, 5696, 5331, 5387, 5351, 5412, 5373, 5582, 5651, 5458, 5559, 5313, 5674, 5348, 5275, 5400, 5378, 5401, 5677, 5337, 5318, 5701, 5398, 5434, 5506, 5259, 5350, 5296, 5367, 5268, 5266, 5366, 5375, 5503, 5546, 5630, 5631, 5715, 5395, 5577, 5448, 5624, 5607, 5403, 5478, 5399, 5573, 5393, 5320, 5612, 5540, 5406, 5491, 5680, 5426, 5321, 5656, 5534, 5310, 5518, 5386, 5494, 5402, 5414, 5657, 5597, 5471, 5277, 5289, 5617, 5443, 5571, 5453, 5377, 5438, 5620, 5437, 5590, 5336, 5556, 5344, 5258, 5694, 5306, 5449, 5435, 5622, 5251, 5457, 5530, 5592, 5687, 5391, 5583 (16 hits)
1	9	1.0	333.0	Yes	5516.0MHz, -64.0dBm	5497, 5461, 5313, 5389, 5557, 5660, 5466, 5706, 5682, 5448, 5357, 5556, 5317, 5572, 5390, 5610, 5641, 5292, 5485, 5263, 5363, 5327, 5268, 5649, 5604, 5342, 5344, 5627, 5529, 5352, 5685, 5638, 5505, 5331, 5650, 5408, 5499, 5506, 5295, 5722, 5283, 5607, 5332, 5307, 5615, 5510, 5712, 5642, 5719, 5707, 5532, 5711, 5702, 5370, 5520, 5611, 5412, 5539, 5264, 5401, 5725, 5478, 5603, 5341, 5597, 5547, 5333, 5578, 5565, 5608, 5371, 5562, 5477, 5697, 5431, 5549, 5353, 5288, 5570, 5653, 5717, 5622, 5291, 5447, 5692, 5369, 5386, 5345, 5609, 5403, 5444, 5334, 5272, 5714, 5296, 5436, 5409, 5689, 5518, 5277 (15 hits)
2	9	1.0	333.0	Yes	5517.0MHz, -64.0dBm	5316, 5479, 5563, 5613, 5565, 5637, 5639, 5518, 5597, 5366, 5298, 5660, 5624, 5653, 5297, 5600, 5706, 5570, 5583, 5375, 5292, 5434, 5277, 5645, 5484, 5250, 5688, 5446, 5555, 5326, 5389, 5497, 5540, 5312, 5526, 5541, 5704, 5574, 5525, 5453, 5289, 5461, 5485, 5586, 5354, 5397, 5351, 5447, 5628, 5607, 5391, 5329, 5571, 5286, 5341, 5338, 5673, 5532, 5657, 5714, 5425, 5379, 5665, 5410, 5353, 5251, 5396, 5328, 5395, 5262, 5345, 5512, 5721, 5661, 5547, 5376, 5535, 5368, 5638, 5302, 5530, 5630, 5679, 5371, 5361, 5517, 5488, 5631, 5604, 5519, 5408, 5544, 5272, 5599, 5460, 5486, 5632, 5263, 5715, 5616 (18 hits)
3	9	1.0	333.0	Yes	5518.0MHz, -64.0dBm	5418, 5269, 5593, 5298, 5265, 5516, 5313, 5607, 5527, 5566, 5467, 5685, 5355, 5393, 5569, 5705, 5529, 5621, 5332, 5389, 5603, 5330, 5354, 5253, 5287, 5572, 5662, 5558, 5601, 5275, 5378, 5546, 5460, 5598, 5615, 5722, 5499, 5708, 5251, 5624, 5496, 5384, 5385, 5309, 5697, 5682, 5530, 5485, 5693, 5522, 5364, 5550, 5555, 5560, 5531, 5552, 5303, 5409, 5578, 5679, 5383, 5585, 5302, 5539, 5329, 5545, 5596, 5371, 5334, 5695, 5432, 5530, 5297, 5363, 5280, 5497, 5368, 5639, 5626, 5570, 5684, 5278, 5587, 5267, 5701, 5295, 5465, 5637, 5532, 5399, 5721, 5504, 5650, 5588, 5688, 5471, 5307, 5667, 5591, 5484 (20 hits)
4	9	1.0	333.0	Yes	5519.0MHz, -64.0dBm	5551, 5349, 5593, 5712, 5348, 5421, 5365, 5384, 5669, 5256, 5704, 5262, 5412, 5422, 5574, 5499, 5469, 5354, 5467, 5599, 5336, 5701, 5509, 5541, 5566, 5504, 5530, 5397, 5251, 5320, 5565, 5661, 5578, 5686, 5487, 5614, 5653, 5650, 5530, 5279, 5402, 5646, 5656, 5560, 5341, 5517, 5447, 5291, 5281, 5472, 5652, 5302, 5379, 5539, 5270, 5573, 5492, 5333, 5622, 5633, 5430, 5432, 5554, 5629, 5597, 5485, 5450, 5575, 5572, 5498, 5657, 5309, 5366, 5521, 5393, 5596, 5394, 5638, 5536, 5340, 5616, 5284, 5685, 5466, 5409, 5355, 5514, 5329, 5564, 5548, 5639, 5510, 5488, 5696, 5266, 5439, 5507, 5558, 5502, 5546 (15 hits)
5	9	1.0	333.0	Yes	5520.0MHz, -64.0dBm	5639, 5398, 5445, 5355, 5625, 5642, 5437, 5379, 5288, 5265, 5478, 5485, 5466, 5305, 5477, 5270, 5337, 5272, 5391, 5620, 5494, 5604, 5432, 5304,

						5512, 5392, 5481, 5501, 5341, 5524, 5654, 5334, 5308, 5382, 5405, 5694, 5356, 5474, 5595, 5687, 5320, 5670, 5390, 5621, 5360, 5577, 5318, 5573, 5546, 5550, 5301, 5675, 5338, 5572, 5578, 5340, 5534, 5416, 5448, 5593, 5612, 5697, 5657, 5660, 5480, 5450, 5435, 5389, 5601, 5598, 5669, 5704, 5553, 5681, 5268, 5522, 5700, 5614, 5454, 5294, 5644, 5459, 5616, 5468, 5643, 5525, 5289, 5419, 5518, 5594, 5589, 5588, 5269, 5605, 5536, 5666, 5420, 5561, 5505, 5691 (14 hits)
6	9	1.0	333.0	Yes	5521.0MHz, -64.0dBm	5616, 5445, 5529, 5251, 5589, 5403, 5257, 5366, 5278, 5712, 5595, 5255, 5720, 5663, 5538, 5413, 5331, 5442, 5560, 5337, 5690, 5507, 5283, 5272, 5713, 5351, 5665, 5370, 5482, 5485, 5493, 5567, 5250, 5608, 5384, 5550, 5685, 5680, 5547, 5599, 5686, 5419, 5723, 5697, 5502, 5512, 5530, 5449, 5641, 5468, 5465, 5622, 5625, 5534, 5621, 5519, 5705, 5644, 5545, 5703, 5691, 5594, 5609, 5341, 5593, 5592, 5432, 5489, 5537, 5522, 5503, 5628, 5620, 5424, 5615, 5701, 5510, 5526, 5349, 5717, 5375, 5414, 5629, 5542, 5470, 5450, 5437, 5309, 5446, 5714, 5658, 5566, 5344, 5343, 5378, 5598, 5308, 5643, 5584, 5581 (9 hits)
7	9	1.0	333.0	Yes	5522.0MHz, -64.0dBm	5405, 5314, 5668, 5548, 5378, 5407, 5561, 5353, 5414, 5412, 5688, 5532, 5613, 5514, 5666, 5570, 5421, 5710, 5270, 5348, 5376, 5266, 5331, 5439, 5577, 5645, 5715, 5462, 5327, 5724, 5460, 5505, 5302, 5670, 5292, 5361, 5250, 5259, 5491, 5525, 5477, 5319, 5655, 5625, 5287, 5647, 5344, 5452, 5643, 5604, 5424, 5340, 5575, 5396, 5470, 5482, 5678, 5465, 5722, 5417, 5686, 5656, 5531, 5605, 5723, 5369, 5545, 5288, 5506, 5557, 5463, 5271, 5365, 5632, 5334, 5390, 5584, 5279, 5709, 5363, 5328, 5707, 5581, 5658, 5673, 5549, 5377, 5318, 5571, 5652, 5654, 5410, 5690, 5298, 5541, 5479, 5519, 5313, 5593, 5360 (17 hits)
8	9	1.0	333.0	Yes	5523.0MHz, -64.0dBm	5375, 5492, 5255, 5522, 5331, 5405, 5704, 5364, 5708, 5527, 5600, 5456, 5357, 5596, 5392, 5421, 5353, 5471, 5352, 5348, 5362, 5407, 5325, 5268, 5493, 5424, 5265, 5683, 5457, 5286, 5488, 5555, 5699, 5528, 5595, 5298, 5685, 5659, 5368, 5463, 5549, 5535, 5323, 5491, 5687, 5328, 5380, 5636, 5291, 5261, 5624, 5440, 5718, 5356, 5629, 5317, 5530, 5675, 5588, 5438, 5707, 5667, 5594, 5454, 5607, 5482, 5563, 5650, 5427, 5710, 5721, 5526, 5437, 5581, 5696, 5460, 5478, 5722, 5483, 5519, 5676, 5285, 5557, 5663, 5625, 5706, 5458, 5430, 5518, 5388, 5401, 5381, 5455, 5712, 5465, 5577, 5669, 5257, 5379, 5462 (14 hits)
9	9	1.0	333.0	Yes	5524.0MHz, -64.0dBm	5259, 5288, 5267, 5298, 5389, 5697, 5302, 5373, 5385, 5355, 5311, 5498, 5620, 5723, 5255, 5444, 5606, 5535, 5370, 5459, 5687, 5494, 5654, 5570, 5287, 5552, 5556, 5571, 5401, 5297, 5454, 5413, 5516, 5354, 5342, 5511, 5428, 5625, 5448, 5435, 5722, 5455, 5616, 5378, 5295, 5612, 5628, 5708, 5467, 5607, 5263, 5291, 5292, 5655, 5392, 5532, 5266, 5285, 5301, 5567, 5290, 5376, 5438, 5648, 5468, 5638, 5382, 5313, 5279, 5352, 5282, 5329, 5553, 5375, 5308, 5682, 5667, 5504, 5410, 5581, 5646, 5462, 5572, 5696, 5690, 5322, 5684, 5653, 5661, 5719, 5593, 5386, 5540, 5524, 5691, 5437, 5591, 5536, 5592, 5649 (23 hits)
10	9	1.0	333.0	Yes	5525.0MHz, -64.0dBm	5671, 5483, 5370, 5624, 5566, 5449, 5575, 5532, 5553, 5669, 5431, 5698, 5535, 5422, 5436, 5662, 5338, 5497, 5290, 5489, 5406, 5457, 5719, 5444, 5373, 5723, 5545, 5602, 5670, 5316, 5473, 5337, 5255, 5412, 5447, 5353, 5661, 5267, 5257, 5327, 5387, 5440, 5502, 5331, 5460, 5573, 5551, 5559, 5424, 5495, 5402, 5508, 5665, 5389, 5694, 5593, 5519, 5303, 5579, 5680, 5536, 5322, 5655, 5272, 5333, 5308, 5707, 5701, 5477, 5280, 5293, 5455,

						5403, 5510, 5693, 5439, 5509, 5653, 5712, 5640, 5404, 5644, 5613, 5390, 5450, 5659, 5474, 5540, 5632, 5622, 5702, 5392, 5552, 5475, 5594, 5538, 5461, 5578, 5414, 5539 (12 hits)
11	9	1.0	333.0	Yes	5526.0MHz, -64.0dBm	5446, 5672, 5291, 5310, 5295, 5542, 5684, 5487, 5550, 5392, 5333, 5435, 5309, 5710, 5719, 5269, 5321, 5511, 5328, 5373, 5668, 5643, 5251, 5450, 5404, 5603, 5255, 5323, 5306, 5489, 5270, 5436, 5314, 5472, 5278, 5615, 5572, 5565, 5395, 5564, 5379, 5664, 5629, 5586, 5692, 5297, 5708, 5410, 5685, 5566, 5585, 5442, 5389, 5476, 5600, 5478, 5425, 5688, 5351, 5366, 5359, 5408, 5515, 5383, 5517, 5539, 5617, 5353, 5362, 5504, 5702, 5281, 5593, 5716, 5693, 5343, 5413, 5556, 5322, 5308, 5390, 5548, 5624, 5718, 5569, 5345, 5388, 5700, 5635, 5348, 5357, 5284, 5537, 5581, 5580, 5597, 5613, 5686, 5426, 5570 (19 hits)
12	9	1.0	333.0	Yes	5527.0MHz, -64.0dBm	5652, 5613, 5662, 5705, 5390, 5682, 5659, 5352, 5555, 5472, 5446, 5354, 5525, 5484, 5336, 5688, 5505, 5655, 5443, 5575, 5411, 5689, 5604, 5392, 5360, 5452, 5313, 5585, 5568, 5647, 5704, 5410, 5467, 5308, 5315, 5372, 5378, 5632, 5526, 5506, 5494, 5396, 5486, 5545, 5436, 5312, 5488, 5557, 5712, 5289, 5558, 5550, 5483, 5487, 5296, 5404, 5402, 5250, 5530, 5329, 5627, 5454, 5515, 5651, 5522, 5576, 5343, 5323, 5481, 5532, 5426, 5583, 5279, 5261, 5364, 5514, 5302, 5556, 5690, 5358, 5579, 5322, 5338, 5634, 5530, 5574, 5546, 5614, 5365, 5298, 5314, 5423, 5406, 5501, 5385, 5478, 5673, 5417, 5581, 5450 (16 hits)
13	9	1.0	333.0	Yes	5528.0MHz, -64.0dBm	5459, 5452, 5470, 5588, 5299, 5693, 5595, 5289, 5698, 5385, 5636, 5631, 5462, 5567, 5673, 5471, 5472, 5503, 5634, 5602, 5274, 5606, 5339, 5705, 5617, 5393, 5578, 5569, 5373, 5532, 5269, 5341, 5328, 5375, 5362, 5539, 5608, 5308, 5513, 5538, 5332, 5565, 5688, 5283, 5511, 5360, 5587, 5615, 5628, 5423, 5342, 5275, 5319, 5297, 5597, 5583, 5509, 5710, 5696, 5621, 5359, 5662, 5301, 5612, 5435, 5413, 5690, 5547, 5279, 5400, 5677, 5571, 5575, 5389, 5481, 5386, 5686, 5573, 5312, 5622, 5599, 5551, 5660, 5334, 5466, 5366, 5478, 5407, 5507, 5714, 5678, 5666, 5514, 5397, 5421, 5351, 5643, 5357, 5406, 5346 (13 hits)
14	9	1.0	333.0	Yes	5529.0MHz, -64.0dBm	5377, 5365, 5311, 5361, 5264, 5695, 5724, 5393, 5426, 5718, 5493, 5701, 5410, 5576, 5703, 5693, 5431, 5647, 5659, 5284, 5713, 5418, 5384, 5575, 5523, 5655, 5314, 5711, 5368, 5324, 5641, 5303, 5339, 5614, 5524, 5670, 5508, 5480, 5281, 5556, 5558, 5282, 5380, 5630, 5338, 5420, 5546, 5538, 5421, 5626, 5581, 5585, 5530, 5636, 5272, 5293, 5542, 5485, 5308, 5372, 5632, 5348, 5646, 5673, 5712, 5469, 5531, 5290, 5478, 5537, 5329, 5279, 5499, 5458, 5557, 5723, 5316, 5280, 5386, 5440, 5545, 5255, 5483, 5367, 5642, 5286, 5357, 5512, 5378, 5565, 5624, 5403, 5600, 5521, 5296, 5601, 5504, 5435, 5683, 5721 (20 hits)
15	9	1.0	333.0	Yes	5530.0MHz, -64.0dBm	5461, 5696, 5648, 5573, 5723, 5446, 5429, 5362, 5569, 5460, 5538, 5255, 5686, 5556, 5338, 5491, 5424, 5295, 5524, 5638, 5605, 5257, 5506, 5267, 5679, 5437, 5501, 5664, 5587, 5273, 5421, 5624, 5436, 5310, 5425, 5662, 5717, 5675, 5404, 5535, 5433, 5336, 5539, 5677, 5311, 5649, 5576, 5415, 5394, 5358, 5468, 5456, 5572, 5510, 5513, 5718, 5724, 5661, 5485, 5270, 5434, 5565, 5559, 5427, 5580, 5360, 5385, 5502, 5308, 5371, 5439, 5713, 5283, 5443, 5658, 5458, 5411, 5376, 5398, 5489, 5678, 5668, 5294, 5527, 5442, 5712, 5595, 5289, 5657, 5579, 5670, 5324, 5619, 5494, 5608, 5558, 5492, 5586, 5481, 5373 (13 hits)
16	9	1.0	333.0	Yes	5531.0MHz, -64.0dBm	5485, 5321, 5417, 5269, 5388, 5286, 5608, 5707, 5263, 5523, 5694, 5593, 5581, 5642, 5255, 5349,

						5682, 5583, 5480, 5467, 5351, 5505, 5598, 5644, 5408, 5251, 5722, 5530, 5481, 5357, 5543, 5367, 5652, 5344, 5382, 5592, 5464, 5314, 5282, 5291, 5356, 5510, 5653, 5697, 5261, 5394, 5542, 5416, 5335, 5498, 5358, 5483, 5533, 5611, 5519, 5626, 5250, 5609, 5277, 5488, 5309, 5308, 5258, 5313, 5554, 5632, 5477, 5666, 5298, 5701, 5718, 5643, 5264, 5489, 5337, 5482, 5534, 5645, 5587, 5680, 5650, 5496, 5474, 5679, 5673, 5507, 5302, 5677, 5518, 5689, 5486, 5445, 5712, 5431, 5665, 5717, 5520, 5633, 5698, 5440 (20 hits)
17	9	1.0	333.0	Yes	5532.0MHz, -64.0dBm	5553, 5711, 5261, 5334, 5468, 5447, 5547, 5363, 5583, 5339, 5347, 5375, 5349, 5435, 5620, 5270, 5385, 5343, 5573, 5258, 5716, 5283, 5674, 5492, 5298, 5352, 5575, 5559, 5329, 5426, 5438, 5437, 5588, 5364, 5356, 5543, 5286, 5666, 5635, 5313, 5597, 5526, 5281, 5638, 5467, 5702, 5502, 5282, 5421, 5460, 5338, 5554, 5673, 5449, 5259, 5568, 5404, 5348, 5322, 5346, 5409, 5255, 5513, 5549, 5595, 5530, 5368, 5524, 5497, 5280, 5310, 5378, 5420, 5394, 5512, 5691, 5572, 5587, 5393, 5622, 5608, 5560, 5653, 5256, 5682, 5594, 5539, 5483, 5603, 5687, 5401, 5461, 5523, 5279, 5320, 5714, 5667, 5328, 5305, 5621 (21 hits)
18	9	1.0	333.0	Yes	5533.0MHz, -64.0dBm	5364, 5569, 5421, 5702, 5549, 5624, 5442, 5563, 5463, 5422, 5721, 5565, 5451, 5409, 5375, 5561, 5393, 5573, 5418, 5323, 5613, 5417, 5638, 5466, 5654, 5705, 5550, 5596, 5720, 5560, 5424, 5639, 5452, 5400, 5658, 5372, 5330, 5511, 5600, 5484, 5628, 5438, 5464, 5337, 5621, 5410, 5719, 5575, 5536, 5432, 5642, 5257, 5258, 5486, 5712, 5348, 5289, 5672, 5284, 5277, 5497, 5252, 5269, 5273, 5425, 5668, 5544, 5656, 5570, 5567, 5394, 5461, 5694, 5527, 5376, 5605, 5677, 5447, 5402, 5559, 5548, 5263, 5350, 5253, 5505, 5482, 5708, 5401, 5502, 5327, 5446, 5693, 5671, 5653, 5373, 5399, 5299, 5699, 5609, 5555 (14 hits)
19	9	1.0	333.0	Yes	5534.0MHz, -64.0dBm	5532, 5275, 5644, 5590, 5575, 5401, 5454, 5304, 5262, 5598, 5689, 5567, 5646, 5524, 5661, 5433, 5455, 5393, 5617, 5562, 5497, 5281, 5715, 5267, 5607, 5595, 5539, 5576, 5427, 5588, 5360, 5637, 5329, 5685, 5272, 5467, 5515, 5495, 5415, 5280, 5447, 5655, 5412, 5675, 5348, 5725, 5702, 5366, 5331, 5526, 5400, 5306, 5658, 5406, 5694, 5323, 5414, 5616, 5533, 5358, 5681, 5265, 5548, 5316, 5554, 5288, 5266, 5466, 5390, 5251, 5302, 5483, 5577, 5299, 5503, 5496, 5399, 5397, 5372, 5389, 5517, 5333, 5276, 5722, 5321, 5618, 5520, 5489, 5341, 5398, 5308, 5485, 5626, 5545, 5391, 5443, 5450, 5647, 5568, 5384 (20 hits)
20	9	1.0	333.0	Yes	5535.0MHz, -64.0dBm	5672, 5267, 5420, 5479, 5402, 5492, 5523, 5699, 5329, 5439, 5666, 5671, 5669, 5680, 5434, 5502, 5351, 5667, 5465, 5646, 5520, 5551, 5517, 5451, 5389, 5565, 5692, 5424, 5620, 5602, 5644, 5656, 5353, 5583, 5548, 5655, 5426, 5597, 5663, 5421, 5414, 5665, 5513, 5291, 5585, 5540, 5615, 5462, 5376, 5700, 5293, 5631, 5263, 5292, 5574, 5459, 5458, 5461, 5295, 5417, 5516, 5577, 5446, 5343, 5710, 5627, 5469, 5653, 5660, 5298, 5488, 5608, 5347, 5422, 5442, 5418, 5576, 5521, 5303, 5407, 5413, 5607, 5638, 5503, 5560, 5725, 5259, 5567, 5290, 5701, 5589, 5600, 5526, 5463, 5718, 5673, 5679, 5372, 5530, 5717 (12 hits)
21	9	1.0	333.0	Yes	5536.0MHz, -64.0dBm	5272, 5262, 5254, 5390, 5414, 5270, 5486, 5597, 5673, 5398, 5519, 5441, 5650, 5413, 5309, 5676, 5490, 5488, 5307, 5717, 5334, 5391, 5724, 5631, 5340, 5252, 5393, 5290, 5665, 5370, 5263, 5553, 5403, 5467, 5437, 5549, 5385, 5457, 5708, 5524, 5507, 5264, 5602, 5372, 5687, 5577, 5515, 5313, 5504, 5297, 5545, 5463, 5591, 5557, 5481, 5565, 5487, 5381, 5571, 5331, 5275, 5253, 5452, 5493,

						5449, 5691, 5613, 5663, 5402, 5379, 5562, 5534, 5433, 5485, 5316, 5469, 5480, 5373, 5432, 5411, 5662, 5657, 5371, 5256, 5474, 5540, 5348, 5281, 5288, 5588, 5329, 5610, 5392, 5585, 5346, 5377, 5427, 5693, 5672, 5496 (19 hits)
22	9	1.0	333.0	Yes	5537.0MHz, -64.0dBm	5303, 5673, 5404, 5648, 5671, 5475, 5686, 5591, 5280, 5566, 5627, 5587, 5364, 5363, 5574, 5339, 5441, 5380, 5291, 5414, 5450, 5430, 5382, 5334, 5463, 5672, 5612, 5485, 5268, 5306, 5537, 5332, 5273, 5678, 5477, 5605, 5321, 5287, 5481, 5515, 5541, 5571, 5524, 5635, 5711, 5308, 5312, 5313, 5531, 5505, 5504, 5717, 5288, 5459, 5435, 5437, 5392, 5305, 5499, 5310, 5256, 5482, 5400, 5610, 5692, 5407, 5276, 5572, 5267, 5362, 5255, 5599, 5514, 5603, 5611, 5622, 5457, 5275, 5379, 5317, 5518, 5616, 5383, 5456, 5530, 5397, 5596, 5340, 5366, 5510, 5328, 5282, 5465, 5480, 5579, 5327, 5387, 5315, 5331, 5675 (24 hits)
23	9	1.0	333.0	Yes	5538.0MHz, -64.0dBm	5282, 5629, 5614, 5572, 5556, 5583, 5679, 5641, 5675, 5580, 5496, 5506, 5555, 5351, 5379, 5294, 5455, 5657, 5298, 5655, 5358, 5370, 5717, 5539, 5307, 5690, 5325, 5663, 5645, 5608, 5639, 5519, 5296, 5715, 5469, 5599, 5551, 5530, 5701, 5371, 5392, 5255, 5281, 5445, 5336, 5585, 5413, 5420, 5286, 5454, 5418, 5720, 5632, 5403, 5308, 5658, 5498, 5435, 5304, 5340, 5668, 5288, 5465, 5289, 5446, 5577, 5681, 5568, 5524, 5619, 5724, 5333, 5643, 5708, 5278, 5683, 5456, 5327, 5426, 5489, 5472, 5606, 5503, 5429, 5676, 5694, 5644, 5434, 5313, 5256, 5262, 5560, 5586, 5276, 5617, 5302, 5579, 5719, 5361, 5494 (20 hits)
24	9	1.0	333.0	Yes	5539.0MHz, -64.0dBm	5347, 5349, 5303, 5654, 5701, 5596, 5337, 5255, 5492, 5559, 5707, 5288, 5583, 5468, 5705, 5607, 5530, 5565, 5721, 5406, 5263, 5683, 5557, 5643, 5651, 5251, 5595, 5505, 5641, 5486, 5404, 5409, 5580, 5306, 5679, 5391, 5381, 5395, 5530, 5363, 5332, 5496, 5293, 5680, 5445, 5334, 5459, 5394, 5410, 5422, 5629, 5451, 5655, 5672, 5702, 5475, 5366, 5617, 5575, 5582, 5393, 5351, 5316, 5427, 5604, 5317, 5460, 5458, 5667, 5562, 5385, 5717, 5271, 5270, 5285, 5487, 5700, 5396, 5389, 5481, 5620, 5423, 5431, 5670, 5684, 5353, 5398, 5529, 5719, 5461, 5299, 5652, 5671, 5283, 5320, 5439, 5462, 5579, 5600, 5693 (16 hits)
25	9	1.0	333.0	Yes	5540.0MHz, -64.0dBm	5417, 5397, 5537, 5681, 5672, 5541, 5353, 5261, 5390, 5653, 5257, 5587, 5386, 5666, 5507, 5267, 5715, 5303, 5522, 5677, 5698, 5504, 5616, 5551, 5400, 5529, 5443, 5494, 5426, 5322, 5688, 5544, 5440, 5690, 5352, 5689, 5343, 5528, 5357, 5675, 5451, 5620, 5548, 5701, 5368, 5328, 5499, 5702, 5640, 5575, 5648, 5691, 5298, 5348, 5721, 5644, 5565, 5676, 5297, 5568, 5596, 5463, 5531, 5636, 5532, 5423, 5449, 5671, 5384, 5605, 5313, 5661, 5502, 5311, 5437, 5520, 5545, 5530, 5369, 5413, 5699, 5555, 5654, 5656, 5477, 5704, 5282, 5540, 5356, 5382, 5516, 5712, 5650, 5678, 5484, 5589, 5562, 5580, 5483, 5315 (13 hits)
26	9	1.0	333.0	Yes	5541.0MHz, -64.0dBm	5723, 5497, 5298, 5511, 5288, 5630, 5563, 5621, 5504, 5526, 5615, 5502, 5671, 5391, 5344, 5486, 5420, 5498, 5701, 5285, 5480, 5489, 5291, 5277, 5401, 5273, 5259, 5330, 5519, 5570, 5440, 5589, 5573, 5672, 5610, 5430, 5372, 5597, 5694, 5319, 5302, 5289, 5561, 5700, 5348, 5363, 5679, 5650, 5350, 5426, 5556, 5436, 5448, 5446, 5292, 5719, 5481, 5510, 5398, 5322, 5553, 5562, 5321, 5523, 5715, 5493, 5403, 5660, 5367, 5451, 5717, 5467, 5716, 5539, 5586, 5645, 5307, 5513, 5416, 5564, 5705, 5607, 5424, 5628, 5483, 5594, 5635, 5488, 5516, 5472, 5351, 5303, 5471, 5629, 5478, 5359, 5378, 5275, 5482, 5290 (18 hits)
27	9	1.0	333.0	Yes	5542.0MHz,	5400, 5697, 5605, 5510, 5418, 5551, 5410, 5386,

					-64.0dBm	5543, 5257, 5514, 5356, 5602, 5621, 5460, 5406, 5251, 5339, 5550, 5395, 5347, 5575, 5673, 5593, 5618, 5583, 5577, 5289, 5495, 5327, 5595, 5478, 5449, 5700, 5281, 5457, 5488, 5278, 5599, 5552, 5274, 5718, 5646, 5270, 5633, 5397, 5430, 5295, 5622, 5501, 5486, 5396, 5273, 5489, 5324, 5255, 5435, 5639, 5487, 5458, 5523, 5533, 5584, 5252, 5377, 5370, 5627, 5492, 5614, 5448, 5398, 5716, 5428, 5607, 5589, 5648, 5567, 5536, 5452, 5505, 5590, 5283, 5520, 5513, 5509, 5382, 5287, 5447, 5554, 5475, 5713, 5685, 5355, 5581, 5309, 5709, 5556, 5280, 5564, 5342 (17 hits)
28	9	1.0	333.0	Yes	5543.0MHz, -64.0dBm	5290, 5511, 5405, 5530, 5287, 5660, 5708, 5335, 5268, 5668, 5374, 5547, 5525, 5475, 5510, 5402, 5589, 5320, 5604, 5444, 5720, 5449, 5605, 5326, 5603, 5425, 5676, 5539, 5694, 5434, 5482, 5553, 5602, 5250, 5587, 5430, 5412, 5673, 5512, 5373, 5568, 5523, 5664, 5386, 5557, 5259, 5324, 5376, 5362, 5319, 5682, 5488, 5639, 5509, 5469, 5532, 5640, 5252, 5630, 5496, 5380, 5718, 5647, 5457, 5370, 5427, 5298, 5454, 5367, 5292, 5618, 5598, 5479, 5725, 5565, 5420, 5436, 5481, 5328, 5679, 5562, 5429, 5264, 5480, 5428, 5472, 5276, 5344, 5332, 5633, 5308, 5545, 5305, 5698, 5348, 5687, 5672, 5571, 5567, 5724 (18 hits)
29	9	1.0	333.0	Yes	5544.0MHz, -64.0dBm	5602, 5635, 5303, 5515, 5711, 5351, 5252, 5437, 5518, 5322, 5672, 5684, 5341, 5298, 5307, 5653, 5532, 5567, 5439, 5613, 5289, 5646, 5721, 5365, 5510, 5496, 5430, 5480, 5641, 5461, 5383, 5313, 5704, 5438, 5522, 5618, 5361, 5526, 5470, 5597, 5331, 5694, 5678, 5460, 5633, 5418, 5698, 5329, 5393, 5525, 5388, 5368, 5363, 5253, 5304, 5475, 5558, 5516, 5416, 5317, 5681, 5290, 5277, 5384, 5448, 5690, 5458, 5262, 5292, 5336, 5511, 5420, 5266, 5314, 5693, 5406, 5335, 5401, 5395, 5405, 5521, 5250, 5379, 5457, 5561, 5566, 5687, 5345, 5389, 5372, 5569, 5413, 5306, 5288, 5278, 5610, 5308, 5502, 5321, 5419 (23 hits)

Table 82 FCC frequency hopping radar (Type 6) Test Results

Long Sequence Trial	Result	Radar Frequency / Amplitude
Trial #1	Detected	5530.0MHz, -64.0dBm
Trial #2	NOT Detected	5530.0MHz, -64.0dBm
Trial #3	Detected	5530.0MHz, -64.0dBm
Trial #4	Detected	5530.0MHz, -64.0dBm
Trial #5	Detected	5530.0MHz, -64.0dBm
Trial #6	Detected	5530.0MHz, -64.0dBm
Trial #7	Detected	5530.0MHz, -64.0dBm
Trial #8	Detected	5530.0MHz, -64.0dBm
Trial #9	Detected	5530.0MHz, -64.0dBm
Trial #10	Detected	5530.0MHz, -64.0dBm
Trial #11	Detected	5530.0MHz, -64.0dBm
Trial #12	Detected	5530.0MHz, -64.0dBm
Trial #13	Detected	5530.0MHz, -64.0dBm
Trial #14	Detected	5530.0MHz, -64.0dBm
Trial #15	Detected	5530.0MHz, -64.0dBm
Trial #16	Detected	5530.0MHz, -64.0dBm
Trial #17	Detected	5530.0MHz, -64.0dBm
Trial #18	Detected	5530.0MHz, -64.0dBm
Trial #19	Detected	5530.0MHz, -64.0dBm
Trial #20	Detected	5530.0MHz, -64.0dBm
Trial #21	Detected	5530.0MHz, -64.0dBm
Trial #22	Detected	5530.0MHz, -64.0dBm
Trial #23	Detected	5530.0MHz,

		-64.0dBm
Trial #24	Detected	5530.0MHz, -64.0dBm
Trial #25	Detected	5530.0MHz, -64.0dBm
Trial #26	Detected	5530.0MHz, -64.0dBm
Trial #27	Detected	5530.0MHz, -64.0dBm
Trial #28	Detected	5530.0MHz, -64.0dBm
Trial #29	Detected	5530.0MHz, -64.0dBm
Trial #30	Detected	5530.0MHz, -64.0dBm

Table 83 Long Sequence Waveform Summary

Burst #	# Pulses	Pulse Width (us)	Chirp (MHz)	Interval 1 to 2 (us)	Interval 2 to 3 (us)	Start time (us)
0	2	54.8	10	1615.0	-	0.244472
1	1	62.1	17	-	-	0.999642
2	2	97.9	6	1240.0	-	1.837456
3	1	76.3	15	-	-	2.102078
4	1	90.3	12	-	-	2.942519
5	2	99.1	20	1056.0	-	3.450660
6	3	84.1	6	1846.0	1630.0	4.619682
7	1	62.5	13	-	-	4.789432
8	2	66.4	17	1844.0	-	5.754420
9	2	72.1	16	1586.0	-	6.120596
10	2	76.4	10	1779.0	-	6.843507
11	2	55.8	13	1053.0	-	7.421009
12	1	95.7	15	-	-	8.653515
13	1	69.5	10	-	-	8.801433
14	1	80.8	6	-	-	9.427289
15	1	77.9	16	-	-	10.101823
16	1	94.2	15	-	-	10.865857
17	2	88.2	18	1977.0	-	11.983326

Table 84 Long Sequence Waveform Trial#1 (Detected)

Burst #	# Pulses	Pulse Width (us)	Chirp (MHz)	Interval 1 to 2 (us)	Interval 2 to 3 (us)	Start time (us)
0	2	60.7	13	1355.0	-	0.559512
1	2	86.4	8	1990.0	-	1.115550
2	1	74.6	8	-	-	1.573650
3	2	97.1	11	1126.0	-	2.258856
4	1	83.4	18	-	-	3.183308
5	1	67.4	13	-	-	3.537051
6	1	77.8	7	-	-	4.354162
7	2	62.0	13	1463.0	-	5.173599
8	2	81.0	13	1410.0	-	5.777764
9	1	50.6	19	-	-	6.688261
10	1	85.5	19	-	-	7.578437
11	2	80.3	15	1989.0	-	8.215759
12	2	57.5	16	1301.0	-	8.714756
13	1	97.0	12	-	-	9.857140
14	2	78.5	20	1341.0	-	9.892163
15	2	90.4	16	1712.0	-	11.136330
16	3	80.2	9	1532.0	1537.0	11.698724

Table 85 Long Sequence Waveform Trial#2 (NOT Detected **)**

Burst #	# Pulses	Pulse Width (us)	Chirp (MHz)	Interval 1 to 2 (us)	Interval 2 to 3 (us)	Start time (us)
0	1	66.7	7	-	-	0.191250
1	3	60.6	17	1049.0	1558.0	1.011198
2	1	97.8	13	-	-	2.606016
3	2	92.0	20	1740.0	-	3.182845
4	1	96.0	9	-	-	4.304576
5	3	63.8	6	1399.0	1465.0	5.229707
6	3	89.5	20	1935.0	1356.0	5.759525
7	2	52.8	14	1440.0	-	7.259840
8	2	87.6	15	1995.0	-	7.820720
9	3	96.6	11	1566.0	1964.0	8.418603
10	2	95.6	17	1131.0	-	9.775832
11	2	98.1	12	1110.0	-	10.477835
12	2	58.9	9	1622.0	-	11.820490

Table 86 Long Sequence Waveform Trial#3 (Detected)

Burst #	# Pulses	Pulse Width (us)	Chirp (MHz)	Interval 1 to 2 (us)	Interval 2 to 3 (us)	Start time (us)
0	2	51.1	8	1748.0	-	0.055705
1	2	74.5	19	1296.0	-	1.197754
2	3	73.1	14	1682.0	1826.0	1.807203
3	3	88.0	7	1977.0	1928.0	2.342688
4	2	85.2	17	1787.0	-	3.747820
5	1	86.3	6	-	-	4.003317
6	2	68.6	18	1598.0	-	4.778532
7	1	61.6	15	-	-	5.339643
8	2	94.6	12	1784.0	-	6.716268
9	2	89.0	7	1380.0	-	6.884440
10	3	79.7	7	1110.0	1779.0	7.767761
11	3	62.4	6	1097.0	1348.0	8.583883
12	1	64.5	18	-	-	9.553074
13	2	86.3	10	1494.0	-	10.284184
14	3	93.0	19	1399.0	1354.0	10.944393
15	2	93.8	13	1263.0	-	11.310110

Table 87 Long Sequence Waveform Trial#4 (Detected)

Burst #	# Pulses	Pulse Width (us)	Chirp (MHz)	Interval 1 to 2 (us)	Interval 2 to 3 (us)	Start time (us)
0	2	72.9	13	1758.0	-	0.168499
1	2	62.3	10	1735.0	-	1.832688
2	3	66.6	6	1988.0	1845.0	2.859935
3	2	89.1	14	1766.0	-	3.658401
4	1	80.9	20	-	-	5.802982
5	3	50.6	12	1954.0	1811.0	6.244730
6	1	63.8	12	-	-	7.644907
7	3	89.5	15	1795.0	1157.0	9.327848
8	2	96.7	17	1518.0	-	10.397928
9	2	93.5	13	1225.0	-	11.847367

Table 88 Long Sequence Waveform Trial#5 (Detected)

Burst #	# Pulses	Pulse Width (us)	Chirp (MHz)	Interval 1 to 2 (us)	Interval 2 to 3 (us)	Start time (us)
0	1	60.1	14	-	-	0.643618
1	2	58.2	19	1558.0	-	1.424176
2	2	59.9	14	1373.0	-	2.801296
3	1	82.6	6	-	-	3.223297
4	2	91.9	5	1032.0	-	4.038689
5	1	99.6	17	-	-	5.727460
6	1	64.3	13	-	-	6.691862
7	2	65.4	11	1246.0	-	7.763930
8	1	64.3	9	-	-	8.969317
9	2	68.8	14	1122.0	-	9.373764
10	2	87.7	19	1534.0	-	10.164398
11	1	90.6	20	-	-	11.321591

Table 89 Long Sequence Waveform Trial#6 (Detected)

Burst #	# Pulses	Pulse Width (us)	Chirp (MHz)	Interval 1 to 2 (us)	Interval 2 to 3 (us)	Start time (us)
0	3	83.2	12	1836.0	1262.0	0.208431
1	2	91.9	10	1584.0	-	0.754474
2	3	76.4	7	1946.0	1898.0	1.406319
3	3	90.7	18	1277.0	1592.0	1.969404
4	3	71.3	19	1255.0	1055.0	2.795187
5	2	70.9	8	1830.0	-	3.480447
6	3	74.1	16	1737.0	1169.0	4.150345
7	2	78.1	16	1335.0	-	4.356518
8	2	82.9	7	1199.0	-	5.390542
9	1	57.3	9	-	-	5.429698
10	3	62.8	11	1816.0	1348.0	6.140492
11	3	82.7	10	1226.0	1282.0	6.988002
12	2	97.5	8	1107.0	-	7.569101
13	3	60.2	12	1590.0	1471.0	8.296523
14	3	65.5	17	1240.0	1529.0	8.554314
15	3	84.0	12	1000.0	1811.0	9.364104
16	2	59.1	17	1858.0	-	10.166068
17	2	81.9	15	1251.0	-	10.476945
18	2	67.5	18	1077.0	-	11.002522
19	1	52.1	7	-	-	11.727585

Table 90 Long Sequence Waveform Trial#7 (Detected)

Burst #	# Pulses	Pulse Width (us)	Chirp (MHz)	Interval 1 to 2 (us)	Interval 2 to 3 (us)	Start time (us)
0	2	76.5	6	1059.0	-	0.212725
1	3	72.0	8	1311.0	1717.0	0.841156
2	2	80.0	8	1354.0	-	1.733612
3	3	65.1	9	1612.0	1922.0	2.350334
4	1	89.8	6	-	-	2.854834
5	1	80.2	12	-	-	3.576585
6	3	61.6	13	1263.0	1117.0	4.573314
7	2	96.6	7	1044.0	-	4.680112
8	2	50.5	14	1196.0	-	5.597685
9	2	97.9	10	1368.0	-	6.602394
10	3	93.8	13	1241.0	1135.0	7.203532
11	3	52.7	8	1801.0	1178.0	7.425317
12	2	69.1	10	1381.0	-	8.347692
13	3	50.5	18	1423.0	1894.0	8.746209
14	3	96.1	11	1847.0	1251.0	9.868459
15	1	99.0	18	-	-	10.275978
16	2	87.8	6	1147.0	-	11.252538
17	1	74.1	7	-	-	11.460549

Table 91 Long Sequence Waveform Trial#8 (Detected)

Burst #	# Pulses	Pulse Width (us)	Chirp (MHz)	Interval 1 to 2 (us)	Interval 2 to 3 (us)	Start time (us)
0	1	96.2	11	-	-	0.446050
1	2	76.7	6	1715.0	-	0.855905
2	3	93.6	13	1846.0	1208.0	2.082351
3	2	78.1	14	1002.0	-	2.464964
4	1	88.1	17	-	-	3.509418
5	3	73.6	14	1227.0	1728.0	3.691858
6	3	99.7	6	1968.0	1692.0	4.861391
7	1	59.8	15	-	-	5.271595
8	2	69.4	12	1380.0	-	5.888880
9	2	93.6	6	1350.0	-	6.371681
10	2	86.3	14	1132.0	-	7.631942
11	2	53.0	11	1813.0	-	8.047986
12	2	96.0	17	1594.0	-	8.683866
13	3	92.4	8	1383.0	1243.0	9.528199
14	3	63.8	18	1065.0	1478.0	10.199739
15	3	61.0	10	1561.0	1826.0	10.889540
16	2	55.1	6	1596.0	-	11.448977

Table 92 Long Sequence Waveform Trial#9 (Detected)

Burst #	# Pulses	Pulse Width (us)	Chirp (MHz)	Interval 1 to 2 (us)	Interval 2 to 3 (us)	Start time (us)
0	3	52.2	9	1592.0	1331.0	0.540495
1	2	53.6	18	1681.0	-	1.306743
2	3	77.9	13	1550.0	1710.0	2.354943
3	1	99.1	14	-	-	3.770009
4	3	73.7	12	1338.0	1184.0	4.096123
5	1	81.2	19	-	-	5.568643
6	1	57.3	6	-	-	6.321115
7	3	81.9	13	1142.0	1316.0	7.898575
8	2	92.8	7	1000.0	-	8.923713
9	2	80.0	14	1927.0	-	9.461501
10	2	76.3	16	1482.0	-	10.375370
11	2	59.6	12	1115.0	-	11.594396

Table 93 Long Sequence Waveform Trial#10 (Detected)

Burst #	# Pulses	Pulse Width (us)	Chirp (MHz)	Interval 1 to 2 (us)	Interval 2 to 3 (us)	Start time (us)
0	3	56.3	10	1520.0	1919.0	0.408230
1	1	62.5	14	-	-	0.823051
2	1	74.8	9	-	-	1.797697
3	2	56.9	20	1912.0	-	2.756933
4	3	68.9	13	1343.0	1457.0	3.465168
5	1	83.8	15	-	-	3.798336
6	2	83.3	12	1088.0	-	4.833728
7	2	81.0	18	1756.0	-	5.452088
8	2	61.8	13	1651.0	-	5.969220
9	2	85.9	11	1648.0	-	6.994437
10	2	95.0	13	1245.0	-	7.167152
11	2	74.2	15	1601.0	-	7.988742
12	3	96.6	19	1452.0	1079.0	8.720726
13	2	76.0	19	1178.0	-	9.799686
14	2	84.3	10	1303.0	-	10.130933
15	2	57.6	17	1033.0	-	11.226208
16	1	90.0	9	-	-	11.890105

Table 94 Long Sequence Waveform Trial#11 (Detected)

Burst #	# Pulses	Pulse Width (us)	Chirp (MHz)	Interval 1 to 2 (us)	Interval 2 to 3 (us)	Start time (us)
0	2	88.4	20	1593.0	-	0.714820
1	3	52.1	17	1116.0	1595.0	1.545911
2	3	67.1	12	1363.0	1749.0	2.979968
3	1	58.2	17	-	-	3.399104
4	2	89.5	9	1962.0	-	5.255595
5	2	58.8	6	1240.0	-	6.434021
6	3	88.1	6	1182.0	1284.0	7.040023
7	2	55.7	8	1429.0	-	8.140897
8	3	55.0	6	1028.0	1607.0	9.466746
9	3	96.5	11	1473.0	1204.0	9.838835
10	3	50.4	17	1036.0	1482.0	11.960628

Table 95 Long Sequence Waveform Trial#12 (Detected)

Burst #	# Pulses	Pulse Width (us)	Chirp (MHz)	Interval 1 to 2 (us)	Interval 2 to 3 (us)	Start time (us)
0	2	95.3	7	1951.0	-	0.126908
1	2	86.5	10	1845.0	-	2.353449
2	1	57.7	19	-	-	2.754823
3	2	92.0	19	1730.0	-	4.267103
4	2	97.6	9	1416.0	-	5.095237
5	2	73.7	7	1358.0	-	6.307786
6	2	99.6	9	1156.0	-	7.217333
7	3	86.7	14	1465.0	1156.0	9.526244
8	3	53.6	15	1592.0	1390.0	9.930856
9	2	89.8	7	1793.0	-	11.226557

Table 96 Long Sequence Waveform Trial#13 (Detected)

Burst #	# Pulses	Pulse Width (us)	Chirp (MHz)	Interval 1 to 2 (us)	Interval 2 to 3 (us)	Start time (us)
0	2	65.6	8	1088.0	-	0.254047
1	3	51.6	14	1168.0	1199.0	1.473877
2	2	84.6	15	1173.0	-	2.096427
3	2	51.6	12	1161.0	-	3.203598
4	2	61.3	16	1622.0	-	4.020468
5	3	71.9	18	1505.0	1696.0	5.395991
6	2	53.2	6	1751.0	-	6.113375
7	2	93.7	13	1752.0	-	7.065587
8	2	95.5	18	1496.0	-	8.119079
9	2	99.2	11	1798.0	-	9.523424
10	2	97.3	16	1330.0	-	10.810456
11	1	95.0	11	-	-	11.083288

Table 97 Long Sequence Waveform Trial#14 (Detected)

Burst #	# Pulses	Pulse Width (us)	Chirp (MHz)	Interval 1 to 2 (us)	Interval 2 to 3 (us)	Start time (us)
0	2	56.1	17	1113.0	-	0.382945
1	1	67.9	18	-	-	1.720162
2	3	79.2	13	1464.0	1322.0	2.108305
3	2	95.7	10	1973.0	-	3.204404
4	2	91.8	6	1803.0	-	4.234538
5	1	78.5	13	-	-	5.413792
6	2	62.7	18	1780.0	-	6.022489
7	1	94.6	10	-	-	6.964458
8	2	57.9	9	1859.0	-	7.966247
9	2	57.7	16	1490.0	-	8.633649
10	1	52.5	6	-	-	9.325157
11	1	58.3	17	-	-	10.981934
12	2	53.6	8	1156.0	-	11.980233

Table 98 Long Sequence Waveform Trial#15 (Detected)

Burst #	# Pulses	Pulse Width (us)	Chirp (MHz)	Interval 1 to 2 (us)	Interval 2 to 3 (us)	Start time (us)
0	1	69.3	11	-	-	0.513352
1	3	96.9	19	1458.0	1406.0	1.103357
2	1	61.8	15	-	-	1.571162
3	2	61.2	12	1354.0	-	2.431435
4	2	58.8	19	1388.0	-	3.144309
5	1	94.1	10	-	-	3.800305
6	1	73.2	11	-	-	4.575603
7	1	70.3	9	-	-	5.397248
8	2	61.5	11	1967.0	-	6.330948
9	2	71.1	15	1347.0	-	6.532809
10	2	86.4	11	1560.0	-	7.571549
11	3	50.9	13	1064.0	1778.0	8.014056
12	1	88.6	6	-	-	9.080826
13	2	98.7	6	1810.0	-	9.567152
14	1	72.3	12	-	-	10.210080
15	3	82.1	19	1337.0	1741.0	10.768444
16	1	75.9	10	-	-	11.597153

Table 99 Long Sequence Waveform Trial#16 (Detected)

Burst #	# Pulses	Pulse Width (us)	Chirp (MHz)	Interval 1 to 2 (us)	Interval 2 to 3 (us)	Start time (us)
0	3	99.0	19	1787.0	1019.0	0.670008
1	2	72.0	7	1312.0	-	1.516776
2	2	72.7	14	1721.0	-	2.423466
3	2	54.6	13	1900.0	-	2.992965
4	2	77.4	18	1930.0	-	3.918479
5	2	72.9	8	1475.0	-	4.694083
6	3	87.3	6	1950.0	1298.0	5.691008
7	3	68.7	11	1416.0	1660.0	6.055984
8	3	65.7	14	1330.0	1858.0	7.473626
9	3	58.6	19	1431.0	1107.0	7.938892
10	2	92.1	13	1013.0	-	9.045945
11	1	92.8	15	-	-	9.562836
12	3	91.4	16	1878.0	1856.0	11.004825
13	3	61.3	11	1877.0	1768.0	11.562281

Table 100 Long Sequence Waveform Trial#17 (Detected)

Burst #	# Pulses	Pulse Width (us)	Chirp (MHz)	Interval 1 to 2 (us)	Interval 2 to 3 (us)	Start time (us)
0	3	89.3	7	1968.0	1459.0	0.142409
1	2	79.8	7	1448.0	-	0.948833
2	1	94.0	12	-	-	2.356385
3	1	85.9	7	-	-	2.732911
4	1	71.6	6	-	-	3.783359
5	1	77.7	7	-	-	4.919128
6	2	82.6	10	1920.0	-	5.894706
7	2	72.4	8	1572.0	-	6.119649
8	2	88.0	16	1390.0	-	7.429021
9	2	66.7	18	1946.0	-	7.775535
10	1	58.9	17	-	-	9.186081
11	2	98.7	7	1480.0	-	10.087837
12	3	98.5	13	1267.0	1259.0	10.935150
13	2	80.8	15	1871.0	-	11.301669

Table 101 Long Sequence Waveform Trial#18 (Detected)

Burst #	# Pulses	Pulse Width (us)	Chirp (MHz)	Interval 1 to 2 (us)	Interval 2 to 3 (us)	Start time (us)
0	1	57.1	6	-	-	0.376046
1	1	99.6	14	-	-	1.474767
2	3	97.7	9	1632.0	1848.0	3.797522
3	2	91.4	11	1191.0	-	4.123926
4	3	95.3	13	1866.0	1426.0	5.653650
5	1	88.7	11	-	-	7.286135
6	2	57.3	19	1344.0	-	8.618832
7	3	92.7	17	1640.0	1909.0	10.247981
8	2	75.8	9	1251.0	-	10.709374

Table 102 Long Sequence Waveform Trial#19 (Detected)

Burst #	# Pulses	Pulse Width (us)	Chirp (MHz)	Interval 1 to 2 (us)	Interval 2 to 3 (us)	Start time (us)
0	2	65.2	15	1590.0	-	0.605128
1	3	65.9	7	1155.0	1791.0	1.605242
2	1	73.5	10	-	-	3.547699
3	1	55.4	19	-	-	3.949813
4	1	73.4	16	-	-	5.505425
5	2	68.2	7	1400.0	-	6.811589
6	3	72.4	6	1760.0	1356.0	8.155837
7	2	59.5	12	1096.0	-	9.046976
8	1	70.4	9	-	-	9.885332
9	2	72.8	9	1976.0	-	11.875070

Table 103 Long Sequence Waveform Trial#20 (Detected)

Burst #	# Pulses	Pulse Width (us)	Chirp (MHz)	Interval 1 to 2 (us)	Interval 2 to 3 (us)	Start time (us)
0	2	77.2	18	1970.0	-	0.549865
1	3	71.6	8	1955.0	1903.0	2.878912
2	2	57.8	14	1509.0	-	3.328264
3	2	71.1	6	1926.0	-	5.894770
4	3	68.3	11	1318.0	1133.0	6.164766
5	1	88.6	10	-	-	8.552445
6	1	87.6	13	-	-	9.138168
7	2	88.2	14	1139.0	-	11.493207

Table 104 Long Sequence Waveform Trial#21 (Detected)

Burst #	# Pulses	Pulse Width (us)	Chirp (MHz)	Interval 1 to 2 (us)	Interval 2 to 3 (us)	Start time (us)
0	2	53.6	16	1460.0	-	0.069637
1	3	74.4	16	1270.0	1513.0	0.675534
2	2	89.9	14	1807.0	-	1.346671
3	3	59.0	18	1815.0	1673.0	1.904617
4	2	85.4	8	1057.0	-	3.096986
5	2	58.0	16	1604.0	-	3.162297
6	1	50.9	19	-	-	4.154285
7	2	56.2	19	1073.0	-	4.660631
8	2	78.0	11	1758.0	-	5.132935
9	2	65.6	10	1074.0	-	6.269436
10	1	69.8	6	-	-	6.945603
11	2	62.6	12	1632.0	-	7.182444
12	3	60.5	14	1762.0	1116.0	7.603139
13	2	70.3	11	1486.0	-	8.534255
14	1	97.2	16	-	-	9.461638
15	1	82.3	15	-	-	9.755667
16	2	89.8	19	1341.0	-	10.174914
17	2	89.4	17	1608.0	-	11.233848
18	2	59.0	5	1385.0	-	11.458632

Table 105 Long Sequence Waveform Trial#22 (Detected)

Burst #	# Pulses	Pulse Width (us)	Chirp (MHz)	Interval 1 to 2 (us)	Interval 2 to 3 (us)	Start time (us)
0	3	71.7	18	1538.0	1319.0	0.628436
1	2	95.4	16	1591.0	-	1.205455
2	2	84.5	19	1511.0	-	3.245691
3	2	76.3	9	1989.0	-	3.791423
4	2	83.5	18	1927.0	-	5.031737
5	1	71.7	17	-	-	6.290944
6	2	52.9	6	1866.0	-	7.002284
7	3	99.6	6	1760.0	1690.0	8.638406
8	2	54.6	20	1697.0	-	9.407428
9	1	61.3	15	-	-	10.336492
10	2	78.5	6	1467.0	-	11.708892

Table 106 Long Sequence Waveform Trial#23 (Detected)

Burst #	# Pulses	Pulse Width (us)	Chirp (MHz)	Interval 1 to 2 (us)	Interval 2 to 3 (us)	Start time (us)
0	2	62.1	12	1624.0	-	0.267982
1	3	70.9	18	1907.0	1973.0	0.929923
2	2	51.1	10	1509.0	-	1.500082
3	3	52.6	12	1930.0	1688.0	2.299478
4	2	90.9	17	1927.0	-	2.816169
5	2	92.2	10	1953.0	-	3.754870
6	3	53.4	13	1973.0	1255.0	4.216610
7	2	89.2	16	1817.0	-	4.627343
8	3	66.5	5	1190.0	1157.0	5.564089
9	3	82.1	16	1926.0	1352.0	6.271305
10	3	59.4	10	1797.0	1728.0	6.695289
11	2	61.4	11	1852.0	-	7.207625
12	3	91.6	12	1774.0	1694.0	7.588958
13	2	81.8	15	1223.0	-	8.529884
14	2	52.6	19	1297.0	-	8.933098
15	2	65.5	18	1361.0	-	9.626893
16	2	80.6	7	1670.0	-	10.720232
17	2	85.2	5	1572.0	-	11.071906
18	3	82.3	11	1340.0	1872.0	11.516132

Table 107 Long Sequence Waveform Trial#24 (Detected)

Burst #	# Pulses	Pulse Width (us)	Chirp (MHz)	Interval 1 to 2 (us)	Interval 2 to 3 (us)	Start time (us)
0	3	58.8	10	1087.0	1312.0	0.203809
1	2	53.3	13	1157.0	-	1.620742
2	2	69.4	5	1773.0	-	3.184640
3	2	94.0	14	1053.0	-	3.991069
4	2	87.7	6	1654.0	-	5.456561
5	2	83.4	6	1334.0	-	7.035172
6	2	85.6	18	1112.0	-	7.569767
7	3	66.3	15	1881.0	1366.0	9.168004
8	2	93.0	5	1751.0	-	10.056834
9	1	73.6	9	-	-	10.971280

Table 108 Long Sequence Waveform Trial#25 (Detected)

Burst #	# Pulses	Pulse Width (us)	Chirp (MHz)	Interval 1 to 2 (us)	Interval 2 to 3 (us)	Start time (us)
0	2	84.9	19	1182.0	-	0.318148
1	3	52.1	19	1759.0	1163.0	1.462084
2	1	62.0	7	-	-	2.772823
3	3	67.5	8	1850.0	1699.0	5.138048
4	1	59.4	13	-	-	6.456178
5	3	58.8	8	1054.0	1401.0	7.645009
6	1	77.8	13	-	-	8.579134
7	2	70.3	16	1905.0	-	10.387054
8	1	73.0	10	-	-	11.768119

Table 109 Long Sequence Waveform Trial#26 (Detected)

Burst #	# Pulses	Pulse Width (us)	Chirp (MHz)	Interval 1 to 2 (us)	Interval 2 to 3 (us)	Start time (us)
0	1	51.5	15	-	-	0.609818
1	2	68.6	18	1492.0	-	1.074359
2	1	64.0	12	-	-	1.691913
3	2	53.6	10	1899.0	-	2.798215
4	2	89.1	12	1445.0	-	2.856012
5	2	82.7	11	1596.0	-	3.699391
6	3	87.8	11	1982.0	1666.0	4.749565
7	1	56.9	16	-	-	5.573334
8	3	89.2	9	1324.0	1387.0	6.349810
9	2	79.4	13	1722.0	-	6.418394
10	1	67.1	11	-	-	7.554177
11	2	89.3	7	1864.0	-	8.159600
12	2	65.0	9	1991.0	-	9.052395
13	2	67.8	6	1803.0	-	9.722820
14	1	96.0	12	-	-	10.351468
15	2	53.5	12	1474.0	-	10.789305
16	2	81.8	8	1798.0	-	11.676208

Table 110 Long Sequence Waveform Trial#27 (Detected)

Burst #	# Pulses	Pulse Width (us)	Chirp (MHz)	Interval 1 to 2 (us)	Interval 2 to 3 (us)	Start time (us)
0	1	78.2	6	-	-	0.492559
1	3	76.0	11	1282.0	1487.0	0.800898
2	1	79.6	16	-	-	1.449747
3	1	76.5	18	-	-	2.066890
4	2	82.9	11	1567.0	-	2.544389
5	2	98.9	10	1376.0	-	3.206511
6	3	77.1	9	1695.0	1953.0	3.891766
7	1	53.8	12	-	-	4.228720
8	3	74.7	6	1455.0	1881.0	4.841914
9	3	92.2	11	1169.0	1718.0	5.780975
10	2	70.2	11	1046.0	-	6.297109
11	2	55.8	11	1491.0	-	6.768405
12	3	61.8	12	1012.0	1587.0	7.634481
13	2	98.7	11	1214.0	-	8.113279
14	2	69.6	20	1465.0	-	8.917817
15	3	64.5	17	1770.0	1741.0	9.378326
16	2	71.1	19	1334.0	-	10.137876
17	3	99.4	18	1821.0	1545.0	10.744482
18	3	89.8	7	1997.0	1591.0	11.292124
19	2	70.0	14	1769.0	-	11.582788

Table 111 Long Sequence Waveform Trial#28 (Detected)

Burst #	# Pulses	Pulse Width (us)	Chirp (MHz)	Interval 1 to 2 (us)	Interval 2 to 3 (us)	Start time (us)
0	3	51.6	14	1473.0	1512.0	0.897075
1	2	50.1	15	1670.0	-	2.476422
2	3	68.2	19	1017.0	1452.0	2.748950
3	3	99.7	17	1028.0	1959.0	4.601142
4	1	83.8	19	-	-	5.466125
5	3	59.0	18	1985.0	1884.0	6.704380
6	2	72.6	19	1905.0	-	8.265555
7	1	80.1	12	-	-	10.052216
8	3	65.3	13	1694.0	1654.0	11.172028

Table 112 Long Sequence Waveform Trial#29 (Detected)

Burst #	# Pulses	Pulse Width (us)	Chirp (MHz)	Interval 1 to 2 (us)	Interval 2 to 3 (us)	Start time (us)
0	3	50.1	15	1649.0	1497.0	0.181300
1	2	57.0	14	1861.0	-	1.419005
2	3	96.4	14	1675.0	1612.0	2.510163
3	1	94.9	17	-	-	3.180742
4	1	88.1	18	-	-	4.775224
5	2	97.4	14	1354.0	-	5.560456
6	1	61.8	17	-	-	6.582669
7	2	92.7	16	1916.0	-	7.333438
8	2	59.7	13	1294.0	-	8.137850
9	2	89.7	18	1619.0	-	9.152863
10	2	61.5	8	1384.0	-	10.829860
11	2	53.7	16	1979.0	-	11.115431

Table 113 Long Sequence Waveform Trial#30 (Detected)

Appendix C Test Data Tables and Plots for Channel Closing**FCC PART 15 SUBPART E & RSS-210 DATA**

Waveform Type	Channel Closing Transmission Time ¹		Channel Move Time		Result
	Measured	Limit	Measured	Limit	
Radar Type 1	37.1 ms	60 ms	.464 s	10s	Pass
Radar Type 5	0 ms	60 ms	0 s	10s	Pass

Table 114 FCC Part 15 Subpart E Channel Closing Test Results for 10 MHz Bandwidth

After the final channel closing test the channel was monitored for a further 30 minutes. No transmissions occurred on the channel.

¹ Channel closing time for FCC measurements is the aggregate transmission time starting from 200ms after the end of the radar signal to the completion of the channel move.

Elliott Timing Plots - Channel Closing

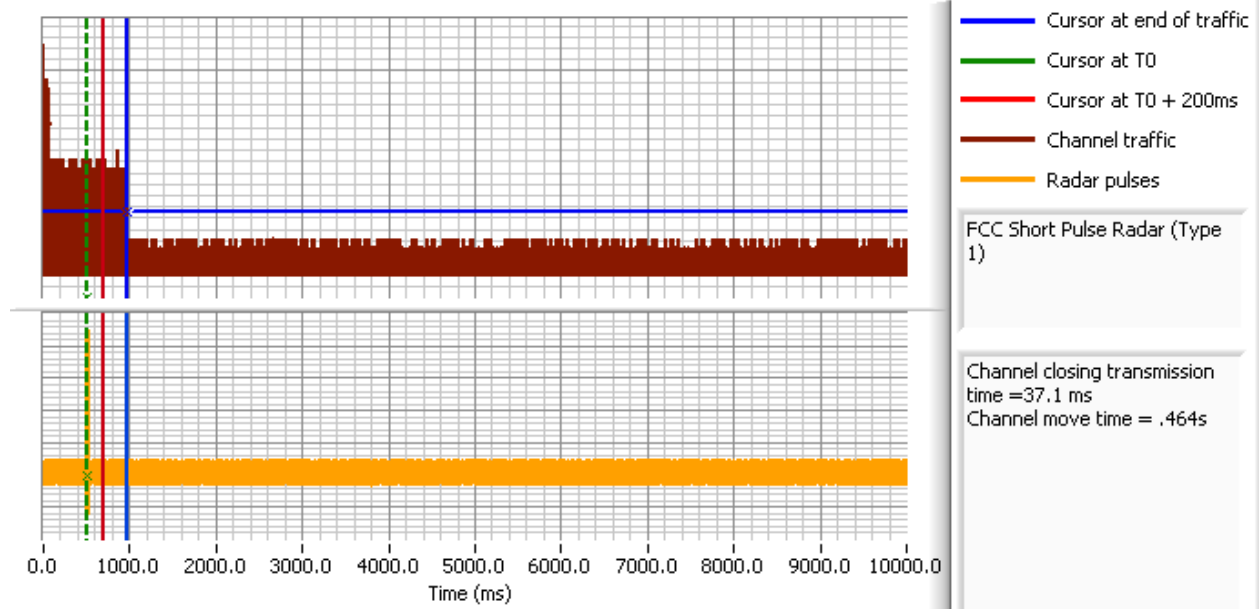

Channel closing transmission time (ms) 37.10 Measured from T0 + 200ms (FCC)
Channel move time (ms) 464 Hi-Res Plot Resolution (ms) 0.020

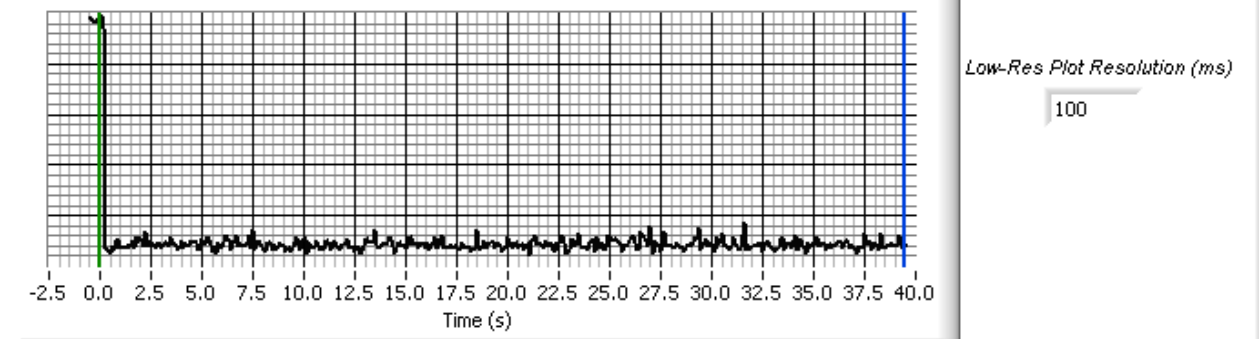

Channel Traffic Low Resolution Analyzer Plot to Verify Channel Move

Closing and Move Time Radar Type 1

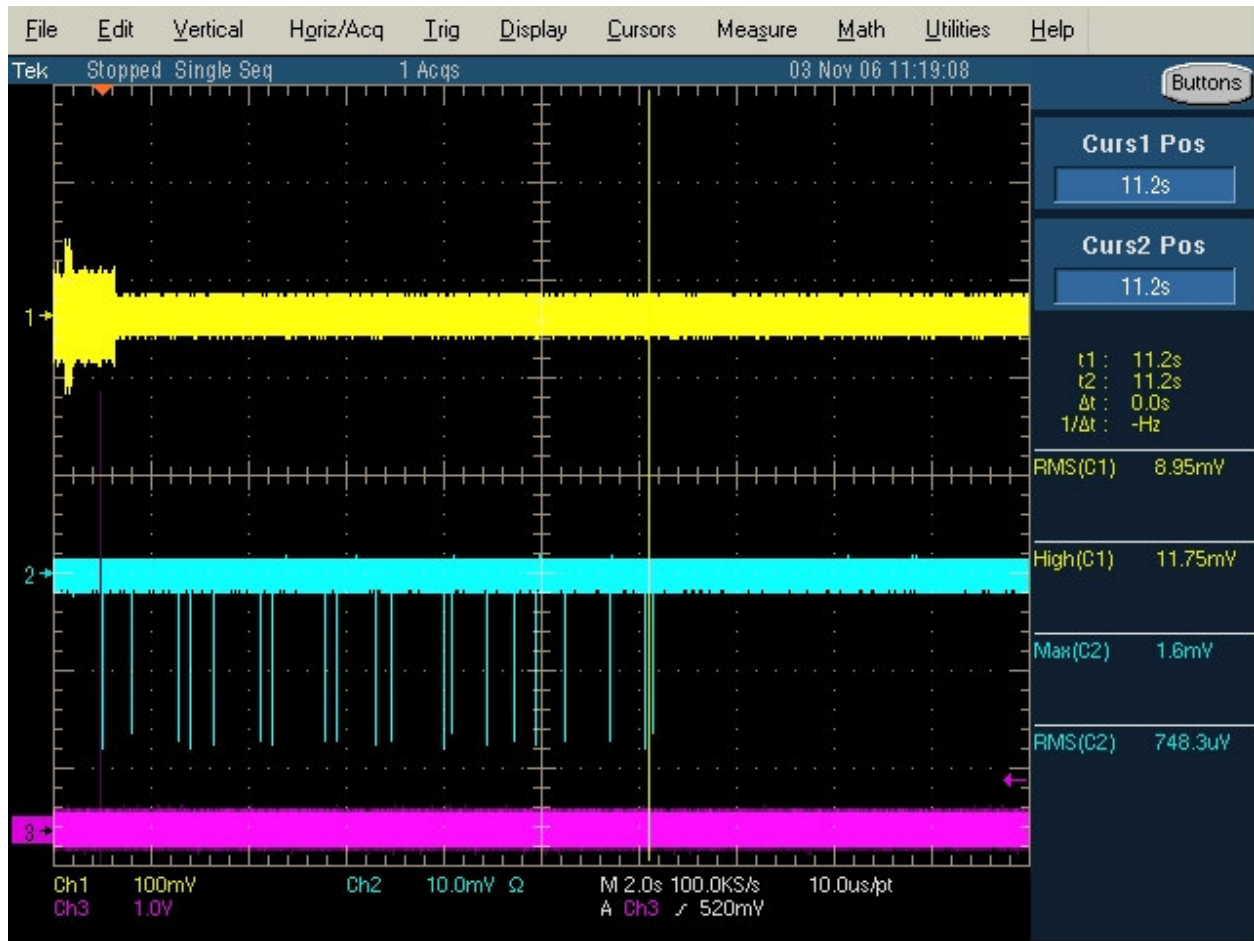

Closing Time Radar Type 5 (Note Channel close before Type 5 12 seconds ended)

12:15:45 NOV 03, 2006

ACTV DET: PEAK
MEAS DET: PEAK QP AVG

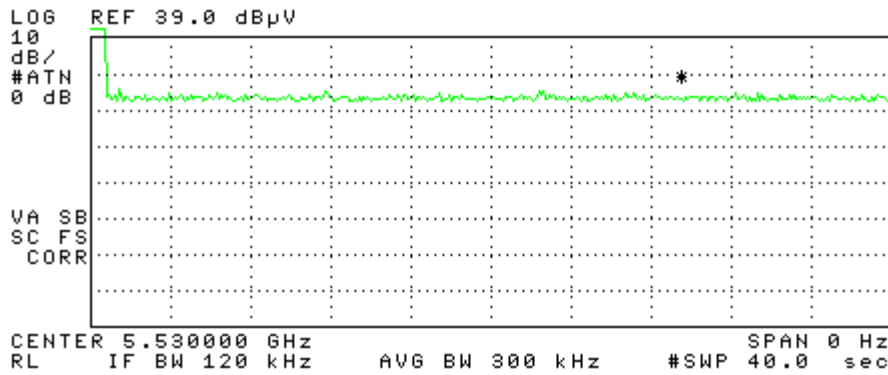

Closing Time Radar Type 5 (after 10 seconds)

FCC PART 15 SUBPART E & RSS-210 DATA

Waveform Type	Channel Closing Transmission Time ¹		Channel Move Time		Result
	Measured	Limit	Measured	Limit	
Radar Type 1	2 ms	60 ms	.498 s	10s	Pass
Radar Type 5	0 ms	60 ms	0 s	10s	Pass

Table 115 FCC Part 15 Subpart E Channel Closing Test Results for 20 MHz Bandwidth

After the final channel closing test the channel was monitored for a further 30 minutes. No transmissions occurred on the channel.

¹ Channel closing time for FCC measurements is the aggregate transmission time starting from 200ms after the end of the radar signal to the completion of the channel move.

Elliott Timing Plots - Channel Closing

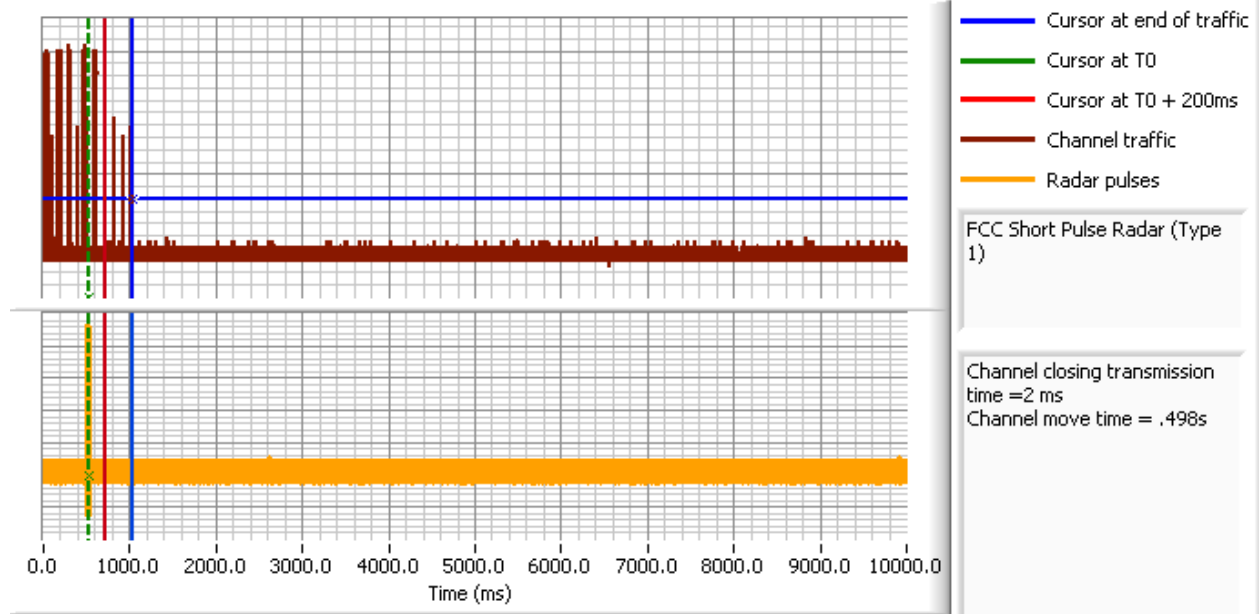

Channel closing transmission time (ms) 2.00 Measured from T0 + 200ms (FCC)
Channel move time (ms) 498 Hi-Res Plot Resolution (ms) 0.400

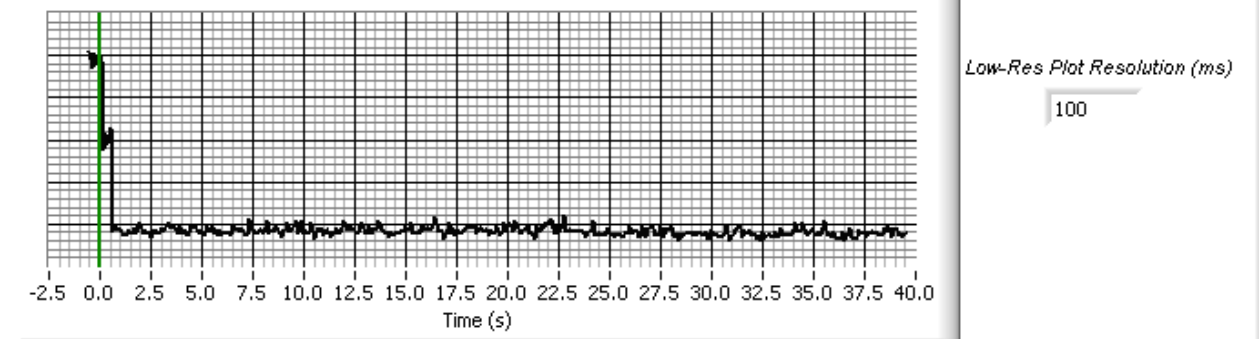

Channel Traffic Low Resolution Analyzer Plot to Verify Channel Move

Elliott Timing Plots - Channel Closing

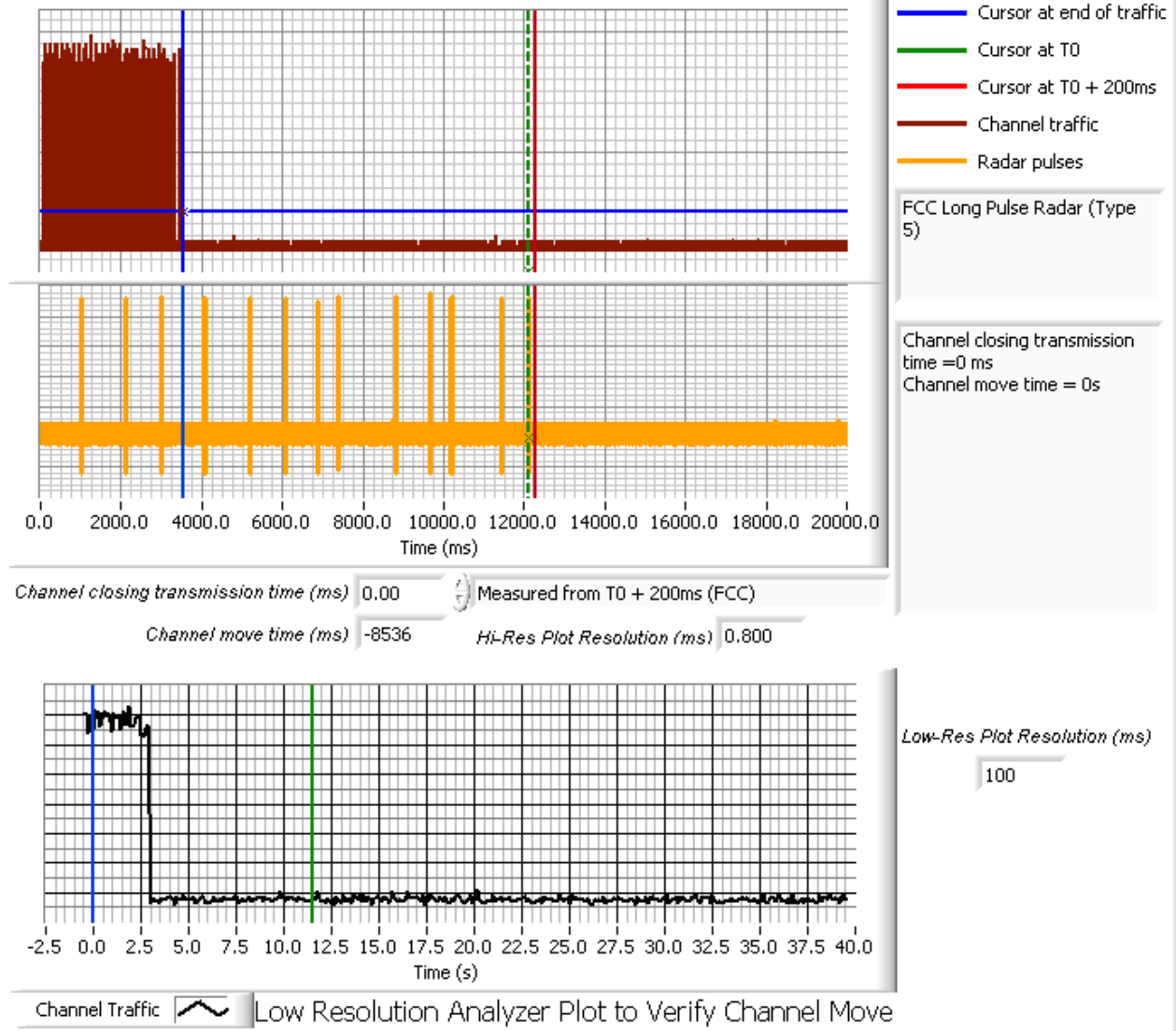

Closing Time Radar Type 5 (Note Channel close before Type 5 12 seconds ended)

FCC PART 15 SUBPART E & RSS-210 DATA

Waveform Type	Channel Closing Transmission Time ¹		Channel Move Time		Result
	Measured	Limit	Measured	Limit	
Radar Type 1	0 ms	60 ms	.4 s	10s	Pass
Radar Type 5	0 ms	60 ms	.8 s	10s	Pass

Table 116 FCC Part 15 Subpart E Channel Closing Test Results for 40 MHz Bandwidth

After the final channel closing test the channel was monitored for a further 30 minutes. No transmissions occurred on the channel.

¹ Channel closing time for FCC measurements is the aggregate transmission time starting from 200ms after the end of the radar signal to the completion of the channel move.

Elliott Timing Plots - Channel Closing

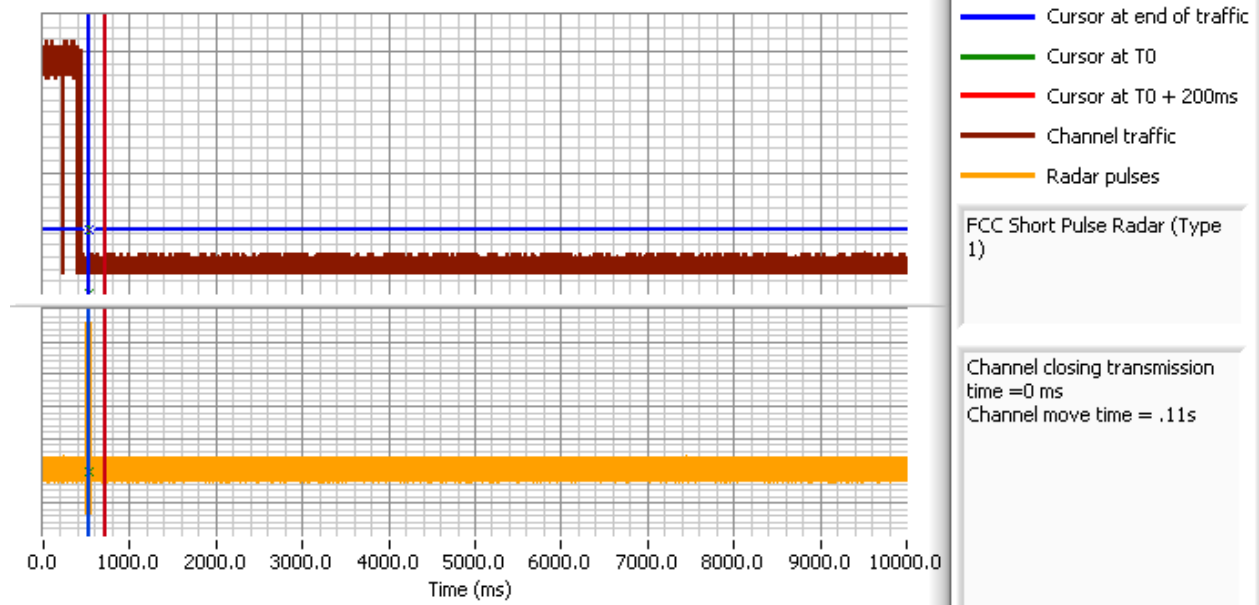

Channel closing transmission time (ms) 0.00 Measured from T0 + 200ms (FCC)
Channel move time (ms) 11 Hi-Res Plot Resolution (ms) 0.400

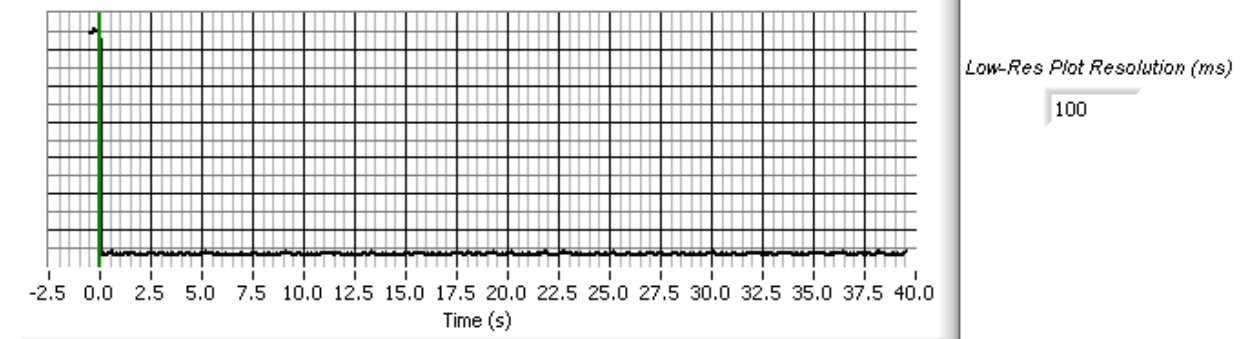

Channel Traffic Low Resolution Analyzer Plot to Verify Channel Move

Elliott Timing Plots - Channel Closing

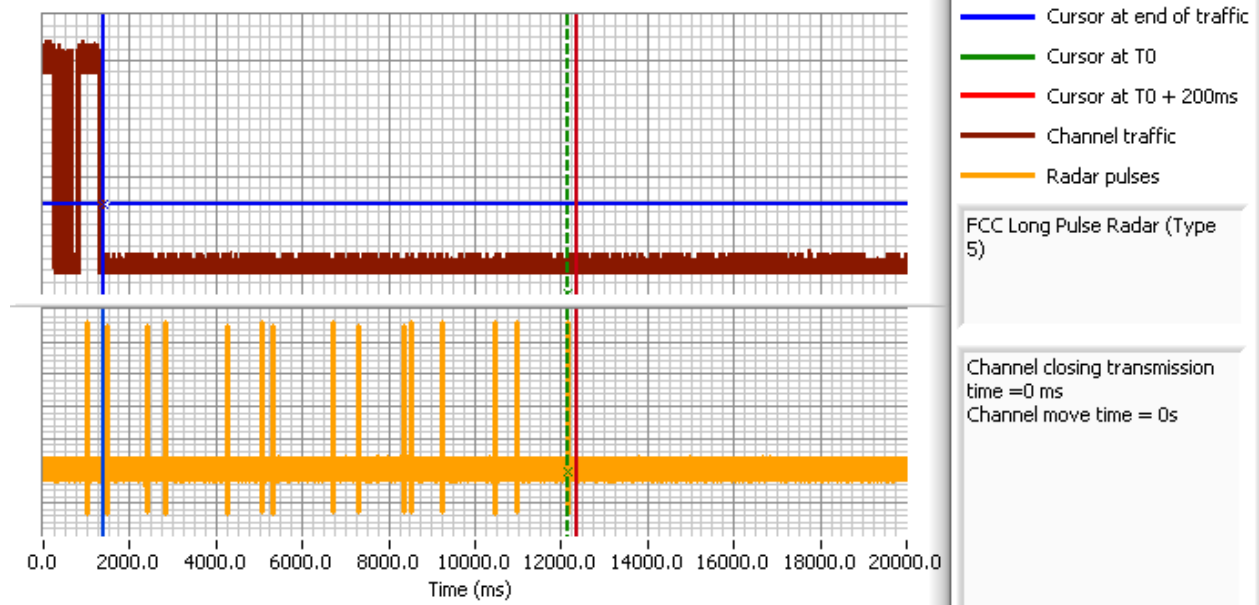

Channel closing transmission time (ms) 0.00 Measured from T0 + 200ms (FCC)
Channel move time (ms) -10744 Hi-Res Plot Resolution (ms) 0.800

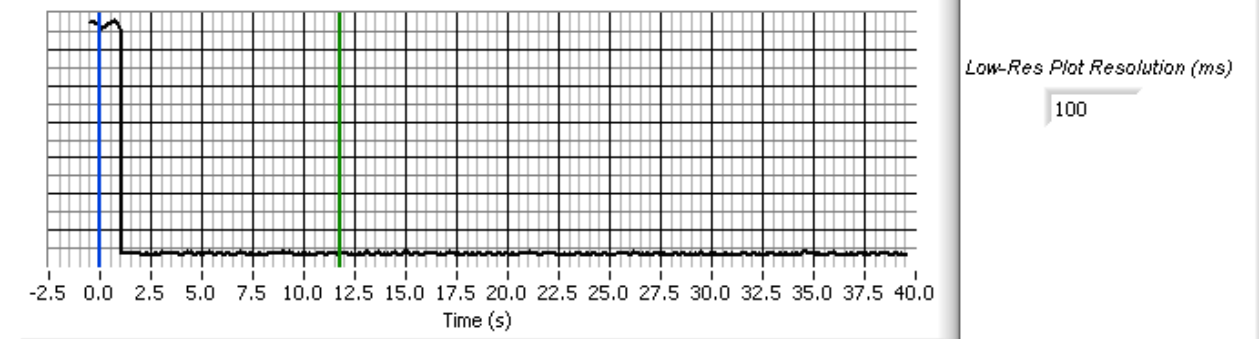

Channel Traffic Low Resolution Analyzer Plot to Verify Channel Move

Appendix D Test Data – Channel Availability Check for 10, 20, and 40 MHz

The first plot shows the start of transmissions approximately 120,000s (2min) after the start of the CAC (no radar applied during the CAC).

Elliott Timing Plots

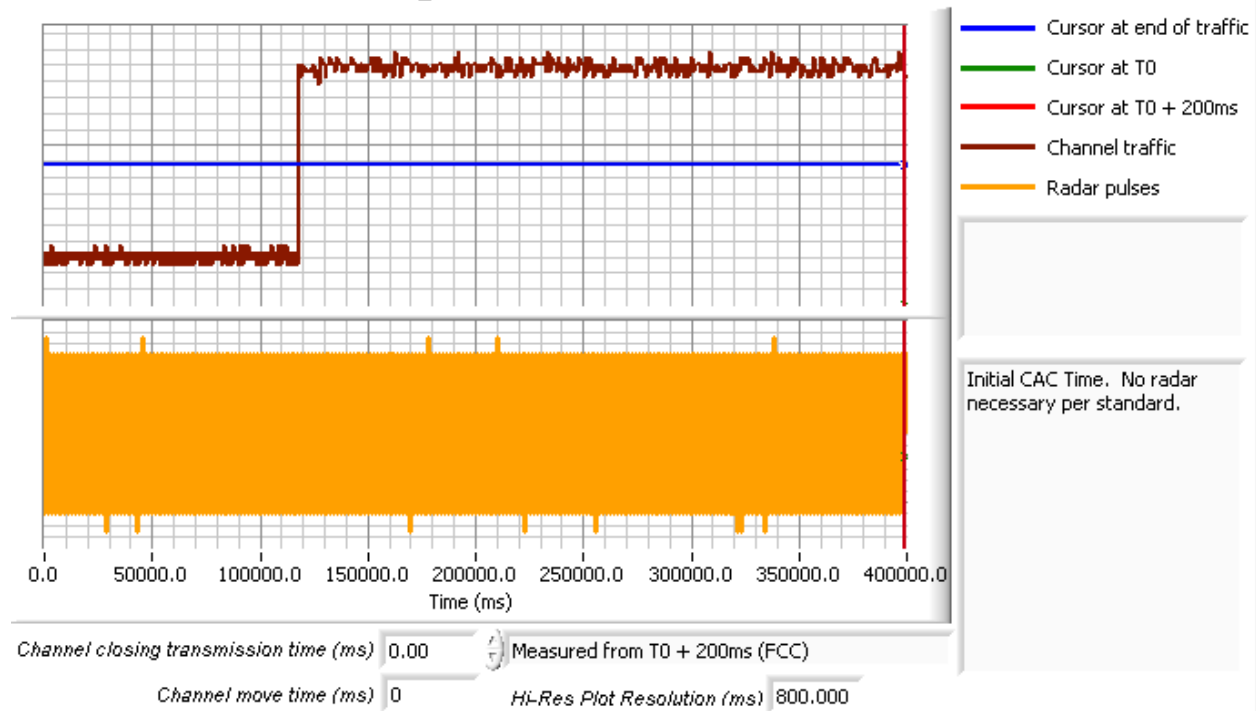

Plot of EUT Power Up sequence (No radar applied)

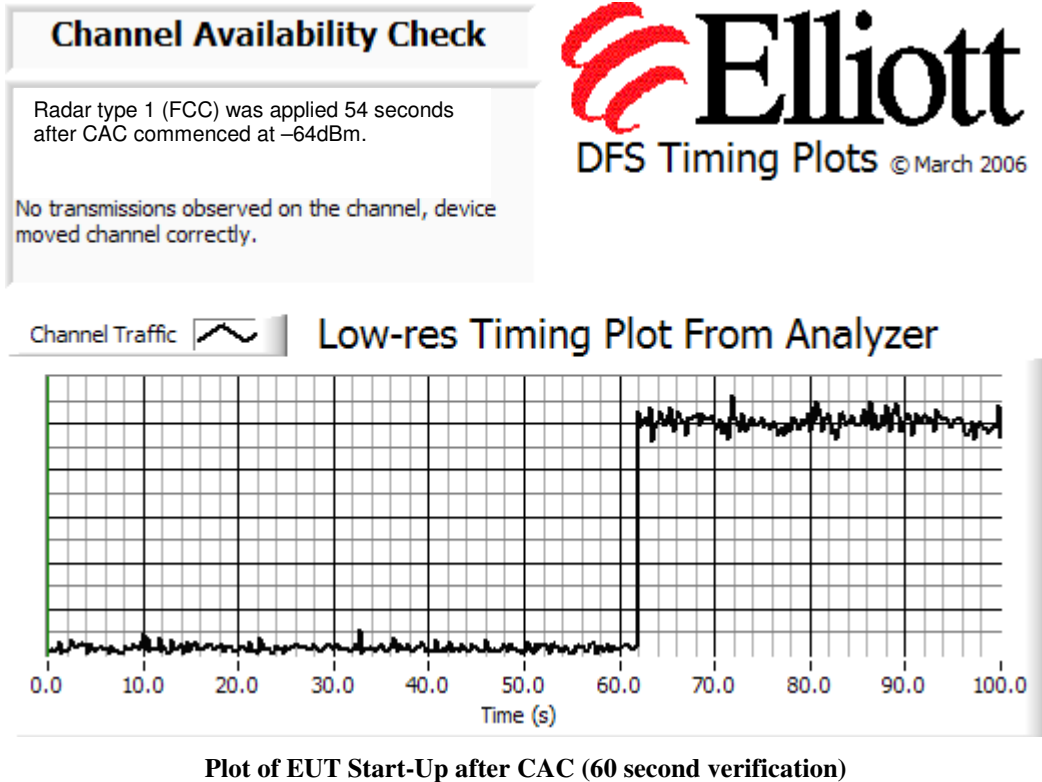

The channel availability check (CAC) was made by applying radar types 1 during the first 6 seconds or last 54 seconds of the CAC period.

The level of the radar signal applied was -64dBm.

The start of each plot is the same for each of the plots and is set to coincide with the start of the Channel Availability Check period.

The plots show that there were no transmissions on the channel after the radar burst was applied during the CAC, and confirm that the CAC is at least 60 seconds. The description of "Channel Traffic" in the plot legend indicates the transmissions from both the radar system and the EUT on the start-up channel. In all cases only the radar burst is observed. The resolution of the plot is not fine enough to resolve the individual pulses within the burst.

Elliott Timing Plots

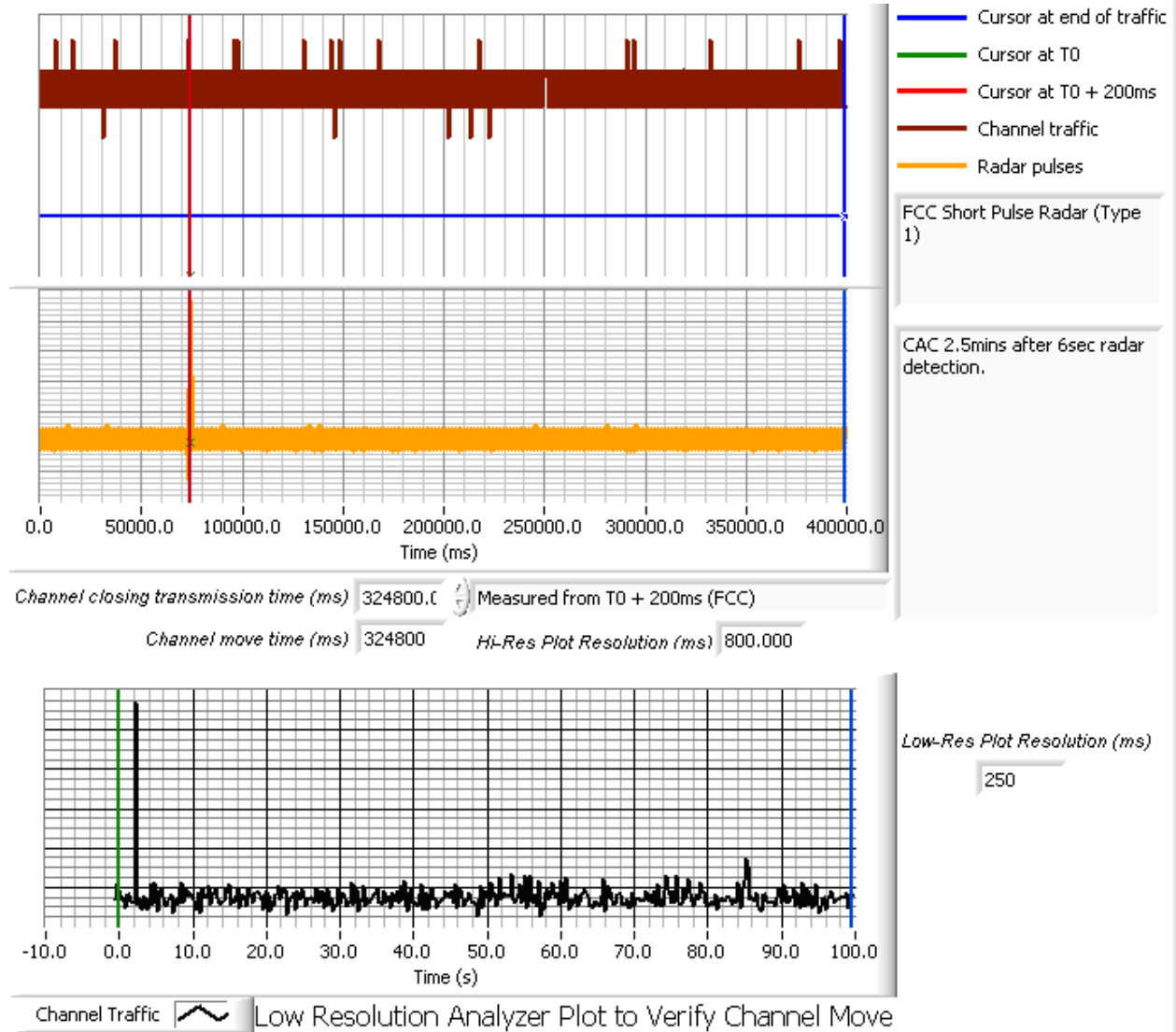

Plot With Radar (FCC 1) applied at Start of CAC (Note: Brown trace from scope is the IF out of the spectrum analyzer and will appear device is transmitting, but this is due to the high resolution of the voltage setting being set low (Scope showing noise floor of Analyzer). Please refer to the next plot and this will show the same characteristics of the trace but in higher voltage setting)

Elliott Timing Plots

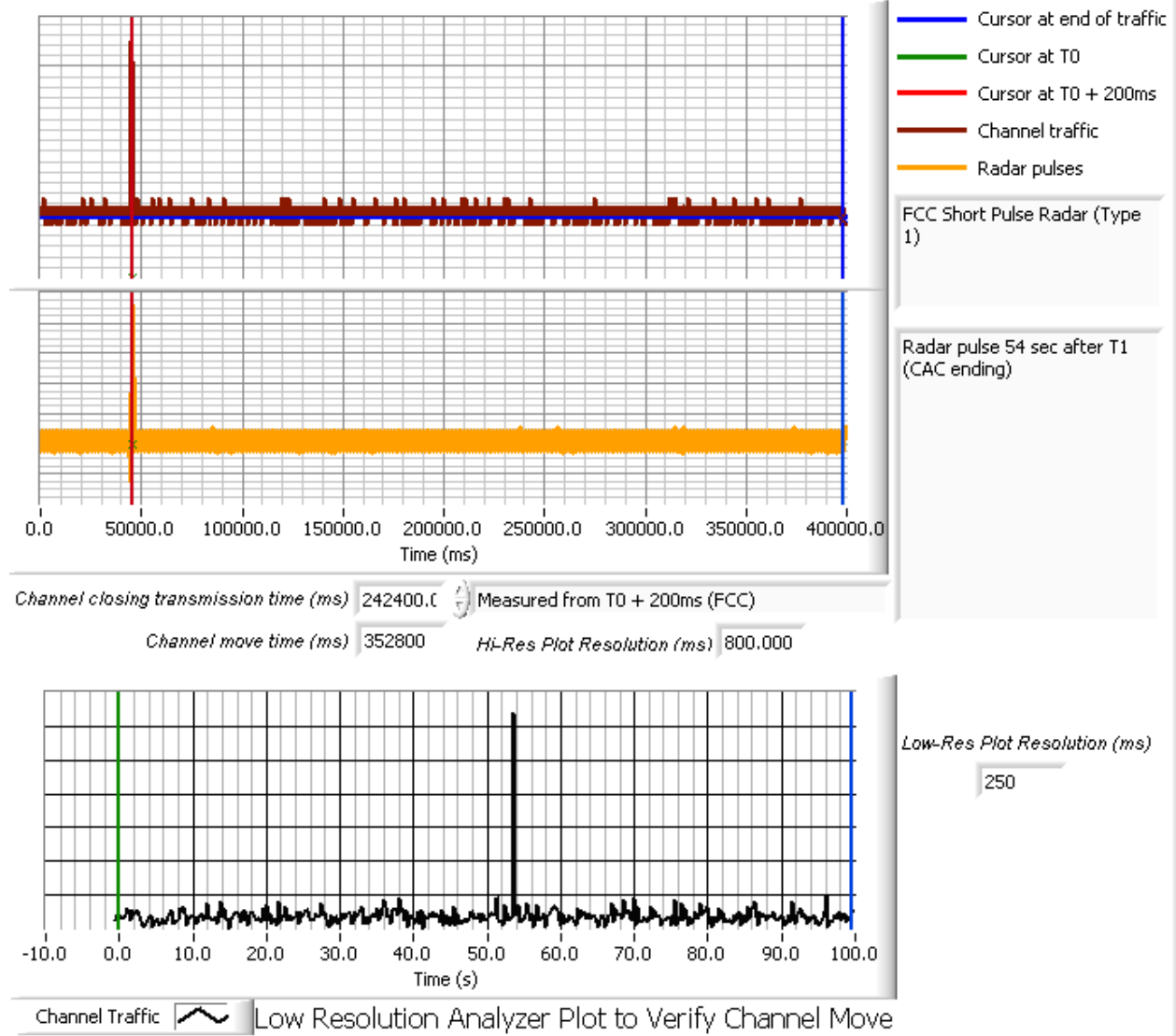

Plot With Radar (FCC 1) applied at End of CAC

Appendix E UNII Detection Bandwidth

Frequency MHz	Percentage detection
5516	0
5517	0
5518	0
5519	0
5520	0
5521 Fl	90
5522	90
5523	90
5524	90
5525	90
5526	90
5527	90
5528	90
5529	90
5530	90
5531	90
5532	90
5533	90
5534	90
5535	90
5536	90
5537	90
5538	90
5539 Fh	90
5540	0
5541	0
5542	0
5543	0
5544	0

99% BW: 10 MHz

Fl	Fh	99% BW	Limit ^{note 1}
(MHz)	(MHz)	(MHz)	(MHz)
5521	5539	18	8

Note 1: Minimum 80% of the UNII
 99% transmission power
 bandwidth.

Frequency MHz	Percentage detection
5510	0
5511	0
5512	0
5513	0
5514	0
5515	0
5516	0
5517	0
5518	0
5519	0
5520 FL	90
5521	90
5522	90
5523	90
5524	90
5525	90
5526	90
5527	90
5528	90
5529	90
5530	90
5531	90
5532	90
5533	90
5534	90
5535	90
5536	90
5537	90
5538	90
5539 FH	90
5540	0
5541	0
5542	0
5543	0
5544	0
5545	0
5546	0
5547	0
5548	0
5549	0
5550	0

99% BW: 17.5 MHz

Fl	Fh	Fh - Fl	Limit ^{note 1}
(MHz)	(MHz)	(MHz)	(MHz)
5520	5539	19	14

Note 1: Minimum 80% of the UNII
 99% transmission power
 bandwidth.

Frequency MHz	Percentage detection
5505	0
5506	0
5507	0
5508	0
5509	0
5510	0
5511 FL	90
5512	90
5513	90
5514	90
5515	90
5516	90
5517	90
5518	90
5519	90
5520	90
5521	90
5522	90
5523	90
5524	90
5525	90
5526	90
5527	90
5528	90
5529	90
5530	90
5531	90
5532	90
5533	90
5534	90
5535	90
5536	90
5537	90
5538	90
5539	90
5540	90
5541	90
5542	90
5543	90
5544	90
5545	90
5546	90
5547	90
5548	90
5549 FH	90
5550	0

99% BW: 40 MHz

Fl	Fh	99% BW	Limit ^{note 1}
(MHz)	(MHz)	(MHz)	(MHz)
5511	5549	38	32

Note 1: Minimum 80% of the UNII
 99% transmission power
 bandwidth.

5551	0
5552	0
5553	0
5554	0
5555	0

Appendix F Test Data – Uniform Loading

The client provided the following uniform loading explanation:

- a) The master device always starts on the channel programmed by the user. Keeping the transmit power off it enter in evaluation period as required by the FCC.
- b) The client device, keeping the transmit power off, either waits on channel programmed by the user if “Auto Scan” facility is disable or scan the available channels if “Auto Scan” is enable until it recognizes the master transmitting.

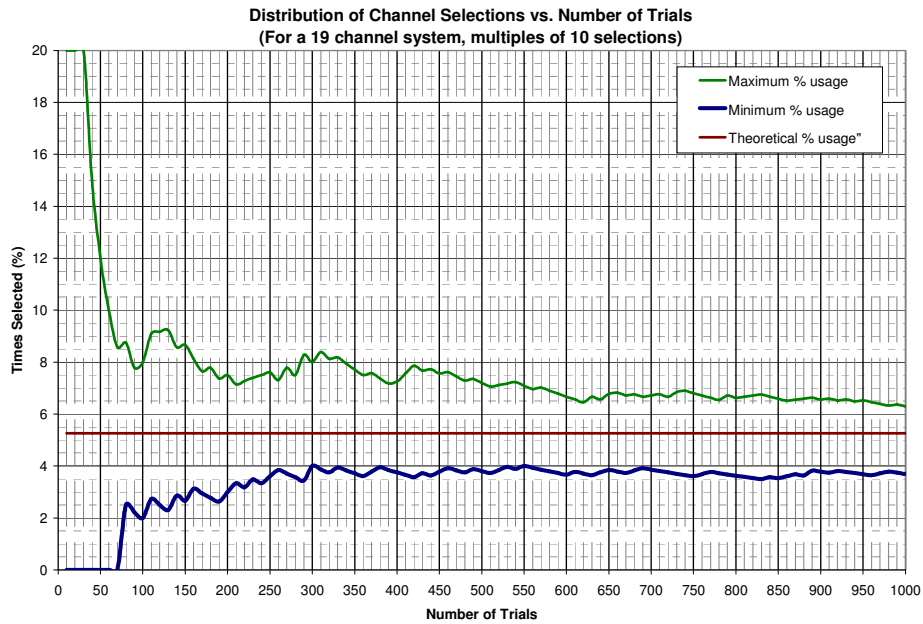

Figure 3 Expected Loading For a 19 Channel System (1,000 Trials)

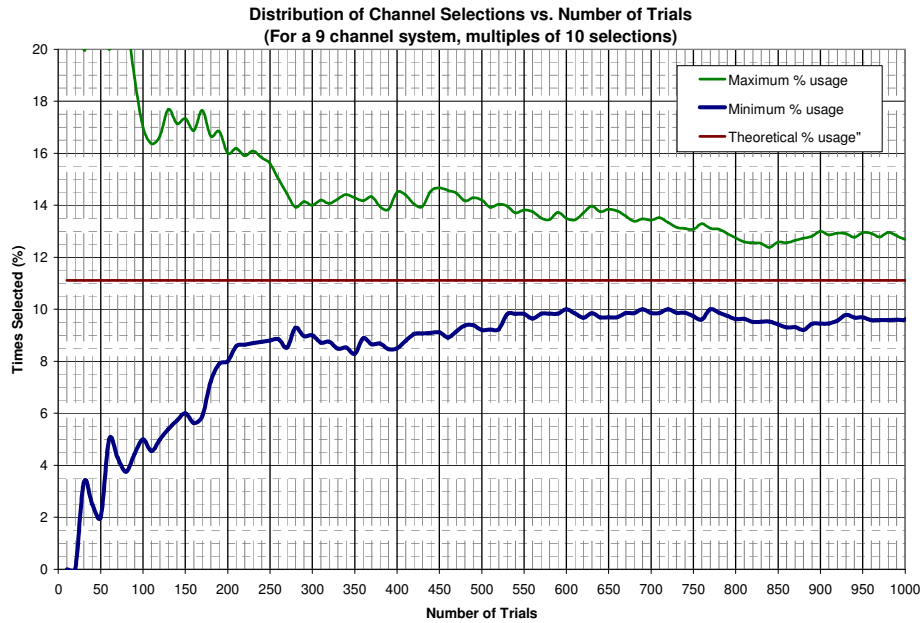

Figure 4 Expected Loading For a 9 Channel System (1,000 Trials)

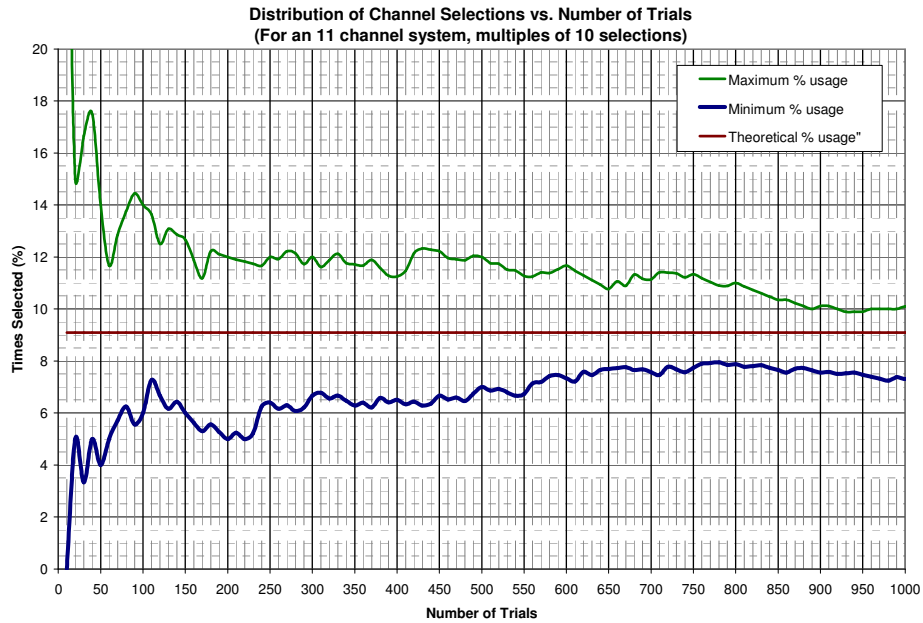

Figure 5 Expected Loading For a 11 Channel System (1,000 Trials)

For a trial size of 50, the expected distribution would be that each channel would be selected between 0% and 12% of the total number of trials. As the actual data of each channel being selected (between 2% and 10% of the time), falls within these bounds it is considered that the device is using a random channel selection algorithm that would produce loading within 10% of the theoretical loading (5.3%).

To obtain a reading within 10% of the theoretical loading on all channels could require somewhere in excess of 6000 trials. Refer to the graph below.

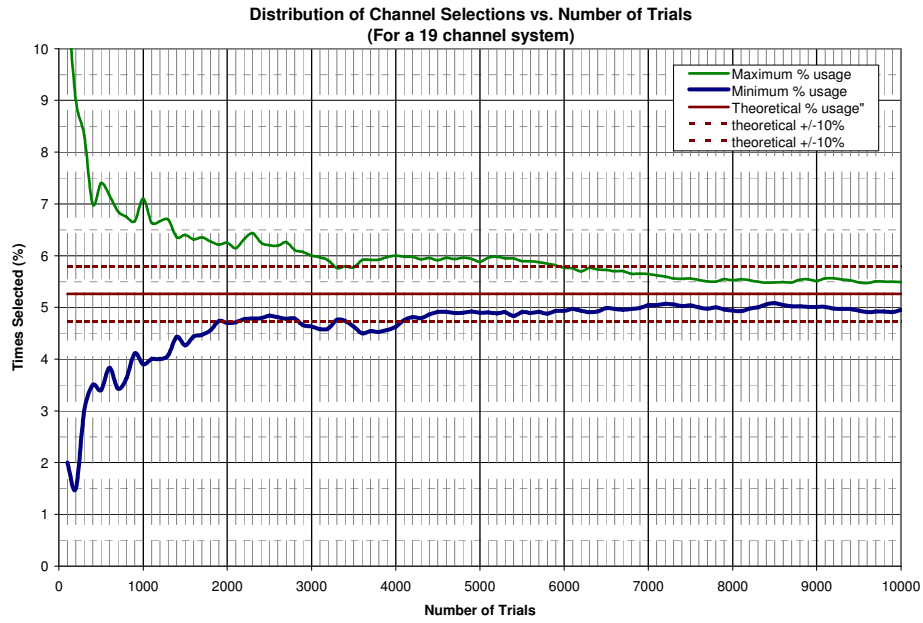

Figure 6 Expected Loading For a 19 Channel System (10,000 Trials)

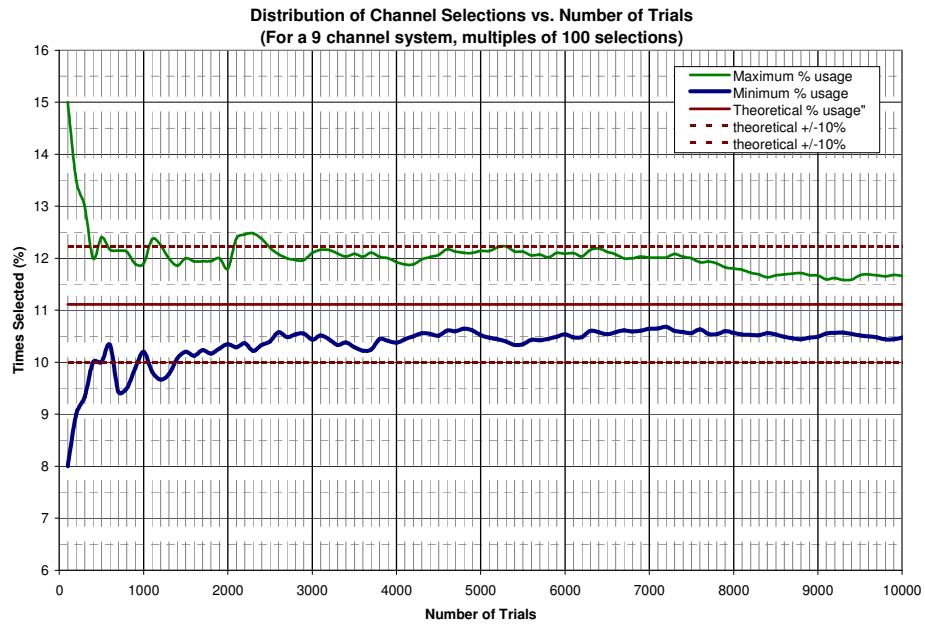

Figure 7 Expected Loading For a 9 Channel System (10,000 Trials)

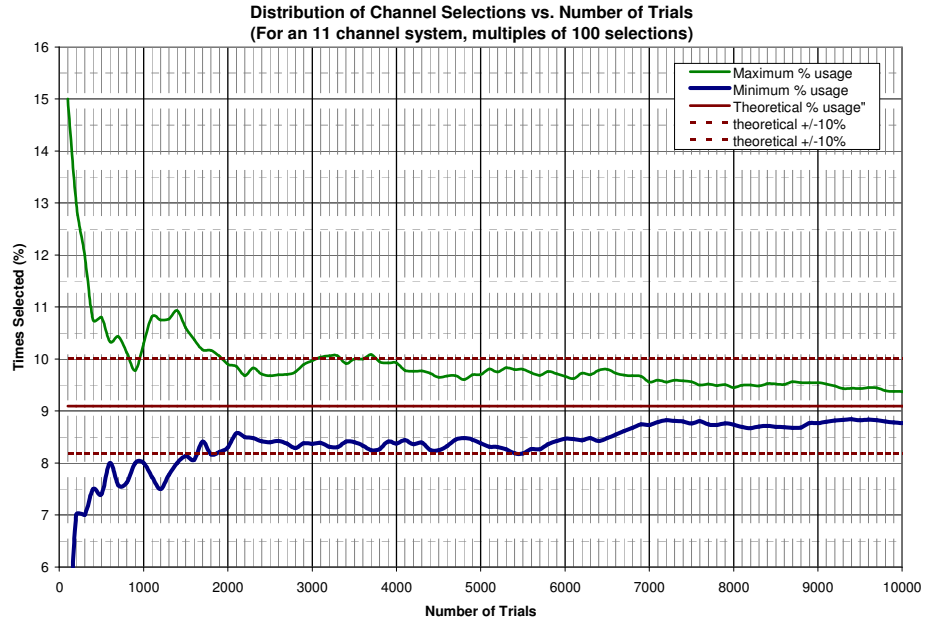

Figure 8 Expected Loading For a 11 Channel System (10,000 Trials)

Appendix G Antenna Specification Sheet

Data sheet included



MT-485028/N

5.15-5.875 GHz 22dBi Subscriber Antenna



Specifications

MTI PART NUMBER		MT – 485028/N			
ELECTRICAL					
FREQUENCY RANGE		5.15-5.875 GHz			
GAIN		21.5 dBi (min) @ 5.15-5.25 GHz 22 dBi (min) @ 5.25-5.875			
VSWR		1.9 : 1 @ 5.15-5.25 GHz 1.7 : 1 @ 5.25-5.875 GHz			
3 dB BEAMWIDTH AZIMUTH		9° (typ)			
ELEVATION		9° (typ)			
POLARIZATION		Linear (Vertical or Horizontal)			
SIDELOBES LEVEL		ETSI EN 302-085 V1.1.2 (2001-02) TS1-TS3			
CROSS POLAR DISCRIMINATION		-28 dB			
CROSS POLARIZATION		ETSI EN 302-085 V1.1.2 (2001-02) TS1-TS3			
F/B RATIO		-35 dB (max)			
INPUT IMPEDANCE		50 (ohm)			
INPUT POWER		6W (max)			
LIGHTNING PROTECTION		DC Grounded			
MECHANICAL					
DIMENSIONS (LxWxD)		305x305X15mm (max)			
WEIGHT		1.2 Kg (max)			
CONNECTOR		N-Type Female			
RADOME		Plastic			
BASE PLATE		Aluminum with chemical conversion coating			
OUTLINE DRAWING		See page 2			
MOUNTING KIT		MT-120018			
ENVIRONMENTAL					
TEST	STANDARD	DURATION	TEMPERATURE	NOTES	
LOW TEMPERATURE	IEC 68-2-1	72 h	-45°C	-	
HIGH TEMPERATURE	IEC 68-2-2	72 h	+70°C	-	
TEMP. CYCLING	IEC 68-2-14	1 h	-45°C +70°C	3 Cycles	
VIBRATION	IEC 60721-3-4	30 min/axis	-	Random4M3	
SHOCK MECHANICAL	IEC 60721-3-4	-	-	4M3	
HUMIDITY	ETSI EN300-2-4 T4.1E	144 h	-	95%	
WATER TIGHTNESS	IEC 529	-	-	IP67	
SOLAR RADIATION	ASTM G53	1000 h	-	-	
FLAMMABILITY	UL 94	-	-	Class HB	
SALT SPRAY	IEC 68-2-11 Ka	500 h	-	-	
ICE AND SNOW	-	-	-	25mm Radial	
WIND SPEED	SURVIVAL	-	-	220 Km/h	
	OPERATION	-	-	160 Km/h	

MT-485028/N

5.15-5.875 GHz 22dBi Subscriber Antenna

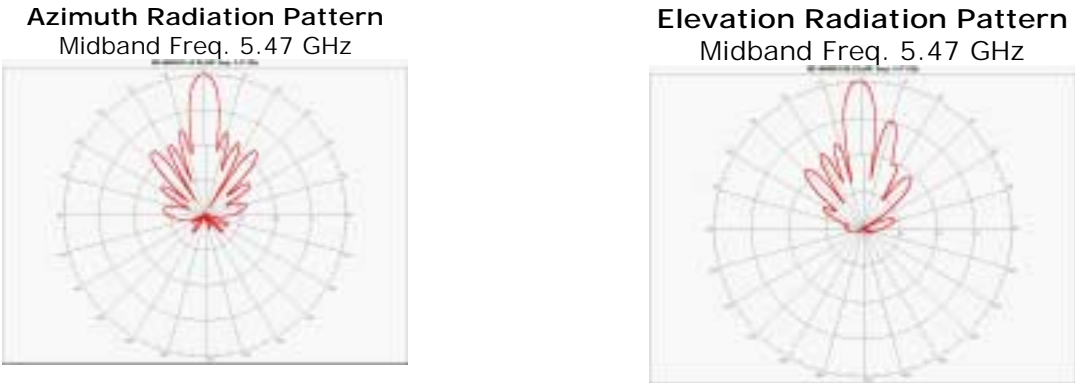

Dimensions [mm]

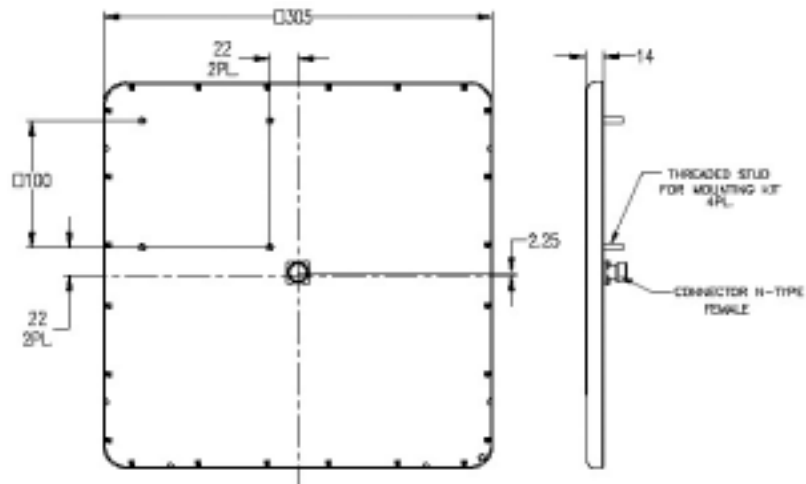

Existing Antenna Versions

MT-485028/N	With N – Type Female connector & DC grounding
-------------	---

MTI group is certified according to ISO 9001 and ISO 14001.

WAIVER!
While the information contained in this document has been carefully compiled to the best of our present knowledge, it is not intended as presentation or warranty of any kind on our part regarding the fitness of the products concerned for any particular use or purpose and neither shall any statement contained herein be construed as a recommendation to infringe any industrial property rights or as a license to use any such rights. The fitness of each product for any particular purpose must be checked beforehand with our specialists.

MTI Wireless Edge Ltd.
11 Hamelacha St.
Afek Industrial Park
Rosh Ha'ayin 48091,
Israel
Tel: +972-3-902-5050
Fax: +972-3-902-5051
www.mtiwe.com

Appendix H Test Configuration Diagram

