

# ENGINEERING TEST REPORT

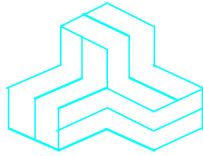

**4G PIV-TWIC Station Extreme**  
**Model No.: EPTVGGCMGW**  
**FCC ID: QC4-EPTVGGCMGW**

*Applicant:*

**Bioscript, Inc.**  
505 Cochrane Drive  
Markham, Ontario  
Canada L3R 8E3

*In Accordance With*

**Federal Communications Commission (FCC)**  
**Part 15, Subpart C**  
**Unlicensed Low Power Transmitter Operating in the Band 13.110-14.010 MHz**  
**UltraTech's File No.: MYT-153F15C225**

This Test report is Issued under the Authority of  
Tri M. Luu, Professional Engineer,  
Vice President of Engineering  
UltraTech Group of Labs



Date: October 22, 2009

Report Prepared by: Dan Huynh

Tested by: Wayne Wu, EMC/RFI Technician

Issued Date: October 22, 2009

Test Dates: Mar. 31, 2009  
Oct. 14, 19 & 20, 2009

- *The results in this Test Report apply only to the sample(s) tested, and the sample tested is randomly selected.*
- *This report must not be used by the client to claim product endorsement by NVLAP or any agency of the US Government.*

## UltraTech

3000 Bristol Circle, Oakville, Ontario, Canada, L6H 6G4  
Tel.: (905) 829-1570 Fax.: (905) 829-8050  
Website: [www.ultratech-labs.com](http://www.ultratech-labs.com), Email: [vic@ultratech-labs.com](mailto:vic@ultratech-labs.com), Email: [tri@ultratech-labs.com](mailto:tri@ultratech-labs.com)



0685



91038



1309



46390-2049



NvLap Lab  
Code 200093-0



SL2-IN-E-1119R



Korea KCC-RRL

CA2049

## TABLE OF CONTENTS

<b>EXHIBIT 1.</b>	<b>INTRODUCTION.....</b>	<b>1</b>
1.1.	SCOPE .....	1
1.2.	RELATED SUBMITTAL(S)/GRANT(S) .....	1
1.3.	NORMATIVE REFERENCES .....	1
<b>EXHIBIT 2.</b>	<b>PERFORMANCE ASSESSMENT.....</b>	<b>2</b>
2.1.	CLIENT INFORMATION .....	2
2.2.	EQUIPMENT UNDER TEST (EUT) INFORMATION .....	2
2.3.	EUT'S TECHNICAL SPECIFICATIONS.....	3
2.4.	LIST OF EUT'S PORTS.....	3
2.5.	ANCILLARY EQUIPMENT .....	3
2.6.	GENERAL TEST SETUP.....	4
<b>EXHIBIT 3.</b>	<b>EUT OPERATING CONDITIONS AND CONFIGURATIONS DURING TESTS.....</b>	<b>5</b>
3.1.	CLIMATE TEST CONDITIONS.....	5
3.2.	OPEPERATIONAL TEST CONDITIONS & ARRANGEMENT FOR TESTS.....	5
<b>EXHIBIT 4.</b>	<b>SUMMARY OF TEST RESULTS.....</b>	<b>6</b>
4.1.	LOCATION OF TESTS .....	6
4.2.	APPLICABILITY & SUMMARY OF EMC EMISSION TEST RESULTS .....	6
4.3.	MODIFICATIONS INCORPORATED IN THE EUT FOR COMPLIANCE PURPOSES.....	6
<b>EXHIBIT 5.</b>	<b>MEASUREMENTS, EXAMINATIONS &amp; TEST DATA FOR EMC EMISSIONS.....</b>	<b>8</b>
5.1.	TEST PROCEDURES.....	8
5.2.	MEASUREMENT UNCERTAINTIES .....	8
5.3.	MEASUREMENT EQUIPMENT USED .....	8
5.4.	COMPLIANCE WITH FCC PART 15 – GENERAL TECHNICAL REQUIREMENTS .....	8
5.5.	OCCUPIED BANDWIDTH .....	9
5.6.	FIELD STRENGTH OF EMISSIONS INSIDE & OUTSIDE THE PERMITTED BAND 13.110-14.010 MHz [47 CFR 15.225 (a) to (d)].....	11
5.7.	FREQUENCY STABILITY [47 CFR 15.225(e)] .....	13
5.8.	POWERLINE CONDUCTED EMISSIONS [47 CFR 15.107(a) & 15.207].....	14
<b>EXHIBIT 6.</b>	<b>TEST EQUIPMENT LIST.....</b>	<b>17</b>
<b>EXHIBIT 7.</b>	<b>MEASUREMENT UNCERTAINTY.....</b>	<b>18</b>
7.1.	LINE CONDUCTED EMISSION MEASUREMENT UNCERTAINTY .....	18
7.2.	RADIATED EMISSION MEASUREMENT UNCERTAINTY .....	19

## EXHIBIT 1. INTRODUCTION

### 1.1. SCOPE

<b>Reference:</b>	FCC Part 15, Subpart C, Sec. 15.225 - Operation within the band 13.110 – 14.010 MHz.
<b>Title:</b>	Title 47, Code of Federal Regulations (CFR), Part 15, Subpart C
<b>Purpose of Test:</b>	To gain FCC Certification Authorization for Section 15.225 - Operation within the Band 13.110 - 14.010 MHz.
<b>Test Procedures:</b>	Both conducted and radiated emissions measurements were conducted in accordance with American National Standards Institute ANSI C63.4 - American National Standard for Methods of Measurement of Radio-Noise Emissions from Low-Voltage Electrical and Electronic Equipment in the Range of 9 kHz to 40 GHz.
<b>Environmental Classification:</b>	Commercial, industrial or business environment

### 1.2. RELATED SUBMITTAL(S)/GRANT(S)

None.

### 1.3. NORMATIVE REFERENCES

Publication	Year	Title
FCC 47 CFR 15	2008	Code of Federal Regulations – Telecommunication
ANSI C63.4	2003	American National Standard for Methods of Measurement of Radio-Noise Emissions from Low-Voltage Electrical and Electronic Equipment in the Range of 9 KHz to 40 GHz
CISPR 22 EN 55022	2008-09, Edition 6.0 2006	Information Technology Equipment - Radio Disturbance Characteristics - Limits and Methods of Measurement
CISPR 16-1-1 +A1 +A2	2006 2006 2007	Specification for radio disturbance and immunity measuring apparatus and methods. Part 1-1: Measuring Apparatus
CISPR 16-1-2 +A1 +A2	2003 2004 2006	Specification for radio disturbance and immunity measuring apparatus and methods. Part 1-2: Conducted disturbances

---

**ULTRATECH GROUP OF LABS**

3000 Bristol Circle, Oakville, Ontario, Canada L6H 6G4  
Tel. #: 905-829-1570, Fax. #: 905-829-8050, Email: [vic@ultratech-labs.com](mailto:vic@ultratech-labs.com), Website: <http://www.ultratech-labs.com>

File #: MYT-153F15C225

October 22, 2009

All test results contained in this engineering test report are traceable to National Institute of Standards and Technology (NIST)

## EXHIBIT 2. PERFORMANCE ASSESSMENT

### 2.1. CLIENT INFORMATION

APPLICANT	
<b>Name:</b>	Bioscrypt, Inc.
<b>Address:</b>	505 Cochrane Drive Markham, Ontario Canada L3R 8E3
<b>Contact Person:</b>	Shiraz Kapadia Phone #: 905-940-7750 Fax #: 905-940-7642 Email Address: shiraz.kapadia@bioscrypt.com

MANUFACTURER	
<b>Name:</b>	Knight Wah Technology Ltd.
<b>Address:</b>	Unit 16 - 19, 3/F Tower B, Regent Centre, 63-73 Wo Yi Hop Road, Kwai Chung, N. T. Hong Kong
<b>Contact Person:</b>	Y.H. Chan Phone #: (852) 2619 0162 Fax #: (852) 2619 0132 Email Address: yhchan@knightwah.com

### 2.2. EQUIPMENT UNDER TEST (EUT) INFORMATION

The following information (with the exception of the Date of Receipt) has been supplied by the applicant.

<b>Brand Name:</b>	Bioscrypt, Inc.
<b>Product Name:</b>	4G PIV-TWIC Station Extreme
<b>Model Name or Number:</b>	EPTVGGCMGW
<b>Serial Number:</b>	Test sample
<b>Type of Equipment:</b>	Low Power Communication Device Transmitter
<b>Input Power Supply Type:</b>	12-24 VDC
<b>Primary User Functions of EUT:</b>	Enroll, verification, communication output

**2.3. EUT’S TECHNICAL SPECIFICATIONS**

<b>Transmitter</b>	
<b>Equipment Type:</b>	Mobile
<b>Intended Operating Environment:</b>	Commercial, light industry & heavy industry
<b>Power Supply Requirement:</b>	7 – 12 VDC
<b>Field Strength:</b>	45.00 dBµV/m at 10 m
<b>Operating Frequency Range:</b>	13.56 MHz
<b>RF Output Impedance:</b>	50 Ω
<b>20 dB Bandwidth:</b>	3.60 kHz
<b>Modulation Type:</b>	ASK
<b>Oscillator Frequencies:</b>	13.56 MHz
<b>Antenna Connector Type:</b>	Integral

**2.4. LIST OF EUT’S PORTS**

<b>Port Number</b>	<b>EUT’s Port Description</b>	<b>Number of Identical Ports</b>	<b>Connector Type</b>	<b>Cable Type (Shielded/Non-shielded)</b>
1	Ethernet 100-Base TX	1	RJ45	Non shielded
2	Host RS-485	1	Header	Non shielded
3	Host RS-232	1	Header	Non shielded
4	Power	2	Bullet and Header	Non shielded
5	Wiegand I/O (8 Lines)	1	Header	Non shielded
6	General Purpose I/O (3 Inputs & 6 Outputs)	1	Header	Non shielded
7	Relay Control (NC, NO & COM)	1	Header	Non shielded
8	USB OTG ( Auxiliary Port)*	1	USB-Micro-AB	Shielded

\* Note: Secured and used by service personnel only

**2.5. ANCILLARY EQUIPMENT**

The EUT was tested while connected to the following representative configuration of ancillary equipment necessary to exercise the ports during tests:

None.

## 2.6. GENERAL TEST SETUP

### 2.6.1. Power Line Conducted Emission Test Setup

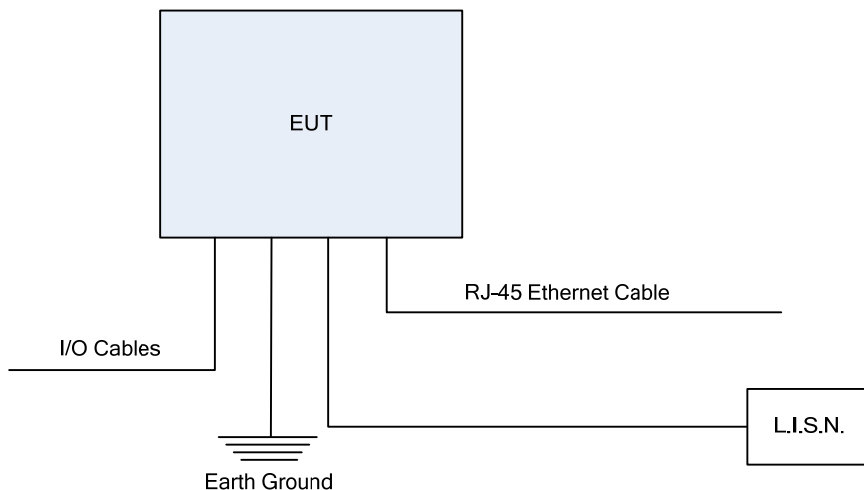

### 2.6.2. Radiated Emission Test Setup

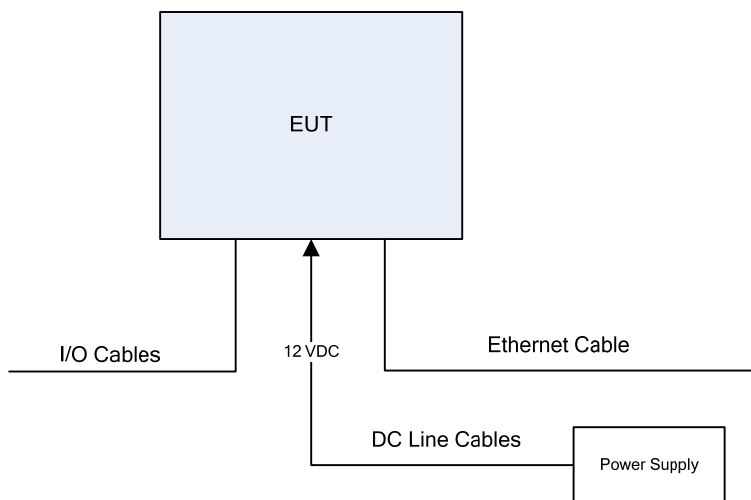

### EXHIBIT 3. EUT OPERATING CONDITIONS AND CONFIGURATIONS DURING TESTS

#### 3.1. CLIMATE TEST CONDITIONS

The climate conditions of the test environment are as follows:

Temperature:	21°C
Humidity:	51%
Pressure:	102 kPa
Power input source:	12 VDC

#### 3.2. OPEPERATIONAL TEST CONDITIONS & ARRANGEMENT FOR TESTS

<b>Operating Modes:</b>	The EUT was configured for continuous transmission for the duration of testing.
<b>Special Test Software:</b>	N/A
<b>Special Hardware Used:</b>	N/A
<b>Transmitter Test Antenna:</b>	The EUT was tested with the antenna fitted in a manner typical of normal intended use as integral antenna equipment.

<b>Transmitter Test Signals:</b>	
<b>Frequency:</b>	13.56 MHz
<b>Transmitter Wanted Output Test Signals:</b>	
▪ RF Power Output (measured maximum output power):	45.00 dBµV/m at 10 m
▪ Normal Test Modulation:	ASK
▪ Modulating signal source:	Internal

## EXHIBIT 4. SUMMARY OF TEST RESULTS

### 4.1. LOCATION OF TESTS

All of the measurements described in this report were performed at Ultratech Group of Labs located in the city of Oakville, Province of Ontario, Canada.

- AC Powerline Conducted Emissions were performed in UltraTech's shielded room, 16'(L) by 12'(W) by 12'(H).
- Radiated Emissions were performed at the Ultratech's 3-10 TDK Semi-Anechoic Chamber situated in the Town of Oakville, province of Ontario. This test site been calibrated in accordance with ANSI C63.4, and found to be in compliance with the requirements of Sec. 2.948 of the FCC Rules. The descriptions and site measurement data of the Oakville 3-10 TDK Semi-Anechoic Chamber has been filed with FCC office (FCC File No.: 91038) and Industry Canada office (Industry Canada File No.: 2049A-3). Expiry Date: 2011-05-01.

### 4.2. APPLICABILITY & SUMMARY OF EMC EMISSION TEST RESULTS

FCC Regulations	Test Requirements	Compliance (Yes/No)
15.203 & 15.204	The transmitter shall use a transmitting antenna that is an integral part of the device	Yes
15.215	20 dB & 99% Bandwidth	Yes
15.225(a) – (d)	Field Strength of Emissions Inside and Outside the Permitted Band 13.110 - 14.010 MHz	Yes
15.225(e)	Frequency Stability	Yes
15.107 & 15.207	Class B - Power Line Conducted Emissions	Yes

### 4.3. MODIFICATIONS INCORPORATED IN THE EUT FOR COMPLIANCE PURPOSES

The following modifications were made for compliance:

#### Ferrite material added outside device on cables:

4G (PIV-TWIC Station or V-Station) Extreme required the addition of a Steward Ferrite P/N: 28A4155-0A2, requiring 1 turn on the IO and Unit Power lines close to the unit.

4G (PIV-TWIC Station or V-Station) Extreme required the addition of a Steward Ferrite P/N: 28A2432-0A2, requiring 1 turn on the Ethernet lines close to the unit RJ45 port.

4G (PIV-TWIC Station or V-Station) Extreme also required the addition of a Steward Ferrite, 28A4155-0A2, requiring 1 turn on the Cooler DC Power lines close to the Cooler board power port.

#### Ferrite material added inside device:

4G (PIV-TWIC Station or V-Station) Extreme required the addition of two Steward Ferrites, P/N: 28B0562-000, and each ferrite required 2 turns on the internal LVDs cable. One ferrite closes to one end of the LVDs cable and another ferrite closes to another end of the LVDs cable.

4G (PIV-TWIC Station or V-Station) Extreme required the addition of two Steward Ferrites, P/N: 28B0562-000, and each ferrite required 2 turns on the internal Venus Sensor cable. One ferrite closes to one end of the Venus Sensor cable and another ferrite closes to another end of the Venus Sensor cable.

---

#### ULTRATECH GROUP OF LABS

3000 Bristol Circle, Oakville, Ontario, Canada L6H 6G4  
Tel. #: 905-829-1570, Fax. #: 905-829-8050, Email: [vic@ultratech-labs.com](mailto:vic@ultratech-labs.com), Website: <http://www.ultratech-labs.com>

File #: MYT-153F15C225  
October 22, 2009

All test results contained in this engineering test report are traceable to National Institute of Standards and Technology (NIST)



4G (PIV-TWIC Station or V-Station) Extreme required the addition of a Steward Ferrite, P/N: 28A2432-0A2, requiring 1 turn on the Magnetic Stripe Card Reader Cable closes to the connector side of LCD/Keypad PCB.

4G (PIV-TWIC Station or V-Station) Extreme also required Nickel Paint – MG Chemicals, Super Shield Nickel Conductive Coating, UL E202609, CAT/PN: 841-3406, applied to Lumidigm Venus Sensor on all sides.

## EXHIBIT 5. MEASUREMENTS, EXAMINATIONS & TEST DATA FOR EMC EMISSIONS

### 5.1. TEST PROCEDURES

This section contains test results only. Details of test methods and procedures can be found in ANSI C63.4 and ULTR-P001-2004.

### 5.2. MEASUREMENT UNCERTAINTIES

The measurement uncertainties stated were calculated in accordance with requirements of UKAS Document LAB 34 with a confidence level of 95%. Please refer to Exhibit 6 for Measurement Uncertainties.

### 5.3. MEASUREMENT EQUIPMENT USED

The measurement equipment used complied with the requirements of the Standards referenced in the Methods & Procedures ANSI C63.4 and CISPR 16-1-1.

### 5.4. COMPLIANCE WITH FCC PART 15 – GENERAL TECHNICAL REQUIREMENTS

FCC Section	FCC Rules	
15.203	<p>Described how the EUT complies with the requirement that either its antenna is permanently attached, or that it employs a unique antenna connector, for every antenna proposed for use with the EUT.</p> <p>The exception is in those cases where EUT must be professionally installed. In order to demonstrate that professional installation is required, the following 3 points must be addressed:</p> <ul style="list-style-type: none"><li>• The application (or intended use) of the EUT</li><li>• The installation requirements of the EUT</li><li>• The method by which the EUT will be marketed</li></ul>	Integral PCB antenna
15.204	<p>Provided the information for every antenna proposed for use with the EUT:</p> <p>(a) type (e.g. Yagi, patch, grid, dish, etc...), (b) manufacturer and model number (c) gain with reference to an isotropic radiator</p>	Only furnished integral antenna will be used in the EUT.

## 5.5. OCCUPIED BANDWIDTH

### 5.5.1. Limits

The 20 dB bandwidth of the emission shall be contained within the band 13.110–14.010 MHz.

### 5.5.2. Method of Measurements

Refer to Ultratech Test Procedures, File # ULTR P001-2004 and ANSI C63.4 for measurement methods

### 5.5.3. Test Data

Test Frequency (MHz)	Occupied Bandwidth (kHz)	
	20 dB BW	99 % BW
13.56	3.60	3.23

**Plot 5.5.3.1. 20 dB Bandwidth**  
 Test Frequency: 13.56 MHz

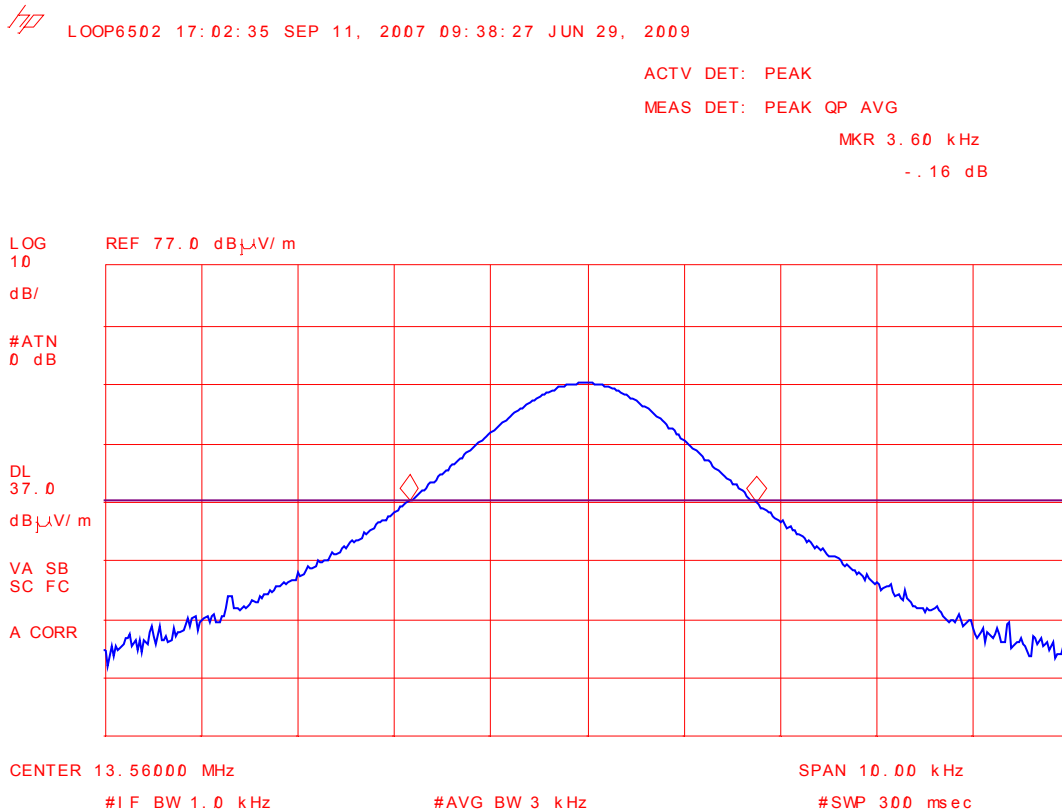

**Plot 5.5.3.2. 99% Occupied Bandwidth**  
Test Frequency: 13.56 MHz



LOOP6502 17:02:35 SEP 11, 2007 09:38:27 JUN 29, 2009

MARKER  $\triangle$   
3.23 kHz  
.39 dB

ACTV DET: PEAK  
MEAS DET: PEAK QP AVG

No user  
Menu

MKR 3.23 kHz  
.39 dB

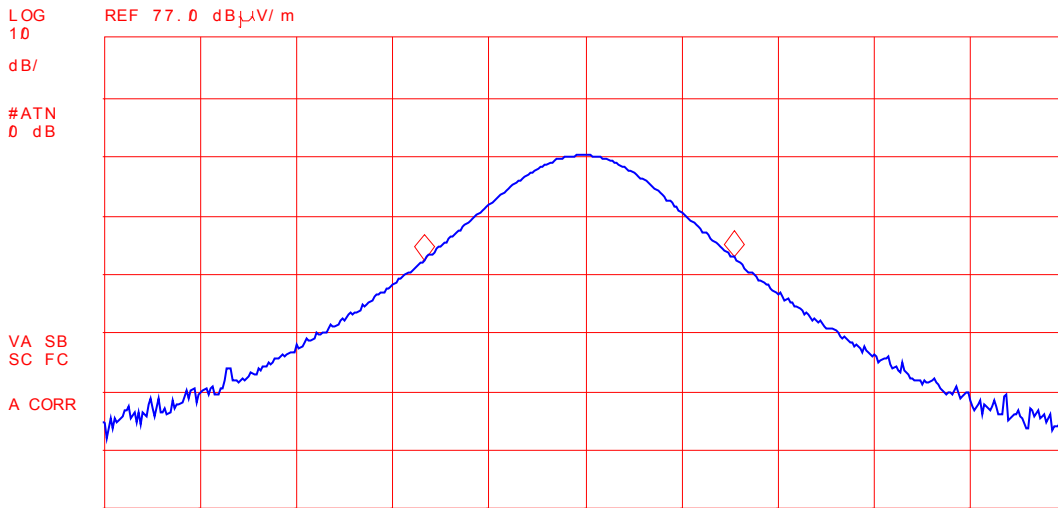

CENTER 13.56000 MHz  
#IF BW 1.0 kHz

#AVG BW 3 kHz

SPAN 10.00 kHz  
#SWP 300 msec

**5.6. FIELD STRENGTH OF EMISSIONS INSIDE & OUTSIDE THE PERMITTED BAND 13.110-14.010 MHz [47 CFR 15.225 (a) to (d)]**

**5.6.1. Limits**

- (a) The field strength of any emissions within the band 13.553-13.567 MHz shall not exceed 15,848 microvolts/meter at 30 meters.
- (b) Within the bands 13.410-13.553 MHz and 13.567-13.710 MHz, the field strength of any emissions shall not exceed 334 microvolts/meter at 30 meters.
- (c) Within the bands 13.110-13.410 MHz and 13.710-14.010 MHz the field strength of any emissions shall not exceed 106 microvolts/meter at 30 meters.
- (d) The field strength of any emissions appearing outside of the 13.110 – 14.010 MHz band shall not exceed the general radiated emission limits in § 15.209.

**47 CFR 15.209(a) – Radiated Emission Limits; general requirements**

Frequency (MHz)	Field Strength Limits (microvolts/m)	Distance (Meters)
0.009 - 0.490	2,400 / F (KHz)	300
0.490 - 1.705	24,000 / F (KHz)	30
1.705 - 30.0	30	30
30 – 88	100	3
88 – 216	150	3
216 – 960	200	3
Above 960	500	3

**5.6.2. Method of Measurements**

Refer to Ultratech Test Procedures, File # ULTR P001-2004 and ANSI C63.4 for measurement methods

Applies to harmonics/spurious that fall in the restricted bands listed in Section 15.205. the maximum permitted average field strength is listed in Section 15.209. A Pre-Amp and high-pass filter are used for this measurement.

- For measurements from 9 KHz to 150 KHz, set RBW = 200 Hz, VBW ≥ RBW, SWEEP=AUTO.
- For measurements from 150 KHz to 30 MHz, set RBW = 10 KHz, VBW ≥ RBW, SWEEP=AUTO.
- For measurements from 30 MHz to 1 GHz, set RBW = 100 KHz, VBW ≥ RBW, SWEEP=AUTO.
- For measurement above 1 GHz, set RBW = 1 MHz, VBW = 1 MHz, SWEEP=AUTO.

If the emission is pulsed, modified the unit for continuous operation, then use the settings above for measurements, then correct the reading by subtracting the peak-average correction factor derived from the appropriate duty cycle calculation. See Section 15.35(b) and (c).

**5.6.3. Test Data**

**Remarks:**

- Radiated spurious emissions measurements were performed from 10 MHz – 10<sup>th</sup> harmonic of the fundamental and all spurious emissions that are in excess of 20 dB below the specified limit shall be recorded.
- For frequencies below 30 MHz, the results measured at 10 m distance shall be extrapolated to 30 m distance using an extrapolation factor of 40 dB/decade (40\*log(10/30)).

**5.6.3.1. Field Strength of Emissions Inside the Permitted Band**

Frequency (MHz)	Measured Field Strength @ 10 m (dBµV/m)	Detector Used (Peak/QP)	Antenna Plane (H/V)	Field Strength @ 30 m Extrapolated Value (dBµV/m)	§ 15.225 Field Strength Limits	Margin (dB)
13.56	45.00	Peak	V	25.9	84.0	-58.1
13.56	41.90	Peak	H	22.8	84.0	-61.2

**5.6.3.2. Field Strength of Emissions Outside the Permitted Band**

Frequency (MHz)	Measured Field Strength @ 3m (dBµV/m)	Detector Used (Peak/QP)	Antenna Plane (H/V)	§ 15.209 Field Strength Limits	Margin (dB)
108.48	31.41	Peak	V	43.5	-12.1
108.48	26.34	Peak	H	43.5	-17.2
122.04	24.46	Peak	V	43.5	-19.0
135.60	33.65	Peak	V	43.5	-9.9
135.60	28.70	Peak	H	43.5	-14.8

**5.7. FREQUENCY STABILITY [47 CFR 15.225(e)]**

**5.7.1. Limits**

The frequency tolerance of the carrier signal shall be maintained within +/- 0.01% of the operating frequency over a temperature variation of -20 degrees to +50 degrees C at normal supply voltage, and for a variation in the primary supply voltage from 85% to 115% of the rated supply voltage at a temperature of 20 degrees C. For battery operated equipment, the equipment tests shall be performed using a new battery.

**5.7.2. Method of Measurements**

Refer to Ultratech Test Procedures, File # ULTR P001-2004.

**5.7.3. Test Data**

<b>Frequency Band:</b>	13.56 MHz
<b>Center Frequency:</b>	13.56 MHz
<b>Frequency Tolerance Limit:</b>	$\pm 0.01\%$ ( $\pm 1356$ Hz)
<b>Max. Frequency Tolerance Measured:</b>	+150 Hz
<b>Input Voltage Rating:</b>	12-24 VDC

Ambient Temperature (°C)	Frequency Drift (Hz)		
	Supply Voltage (Nominal) 12 VDC	Supply Voltage (85 % of Nominal) 10.2 VDC	Supply Voltage (115% of Nominal) 27.6 VDC
-30	+100	--	--
-20	+150	--	--
-10	+50	--	--
0	+150	--	--
+10	+100	--	--
+20	0	0	0
+30	0	--	--
+40	+100	--	--
+50	+50	--	--
+60	+50	--	--

## 5.8. POWERLINE CONDUCTED EMISSIONS [47 CFR 15.107(a) & 15.207]

### 5.8.1. Limits

The equipment shall meet the limits of the following table:

Test Frequency Range (MHz)	Class B Limits (dB $\mu$ V)		Measuring Bandwidth
	Quasi-Peak	Average	
0.15 to 0.5	66 to 56*	56 to 46*	RBW = 9 kHz VBW $\geq$ 9 kHz for QP VBW = 1 Hz for Average
0.5 to 5	56	46	RBW = 9 kHz VBW $\geq$ 9 kHz for QP VBW = 1 Hz for Average
5 to 30	60	50	RBW = 9 kHz VBW $\geq$ 9 kHz for QP VBW = 1 Hz for Average

\* Decreasing linearly with logarithm of frequency

### 5.8.2. Method of Measurements

Refer to Ultratech Test Procedures, File # ULTR P001-2004 and ANSI C63.4 for measurement methods



5.8.3. Test Data

Plot 5.8.3.1. Power Line Conducted Emission  
 Line Voltage: 12 VDC  
 Line Tested: Positive

Current Graph

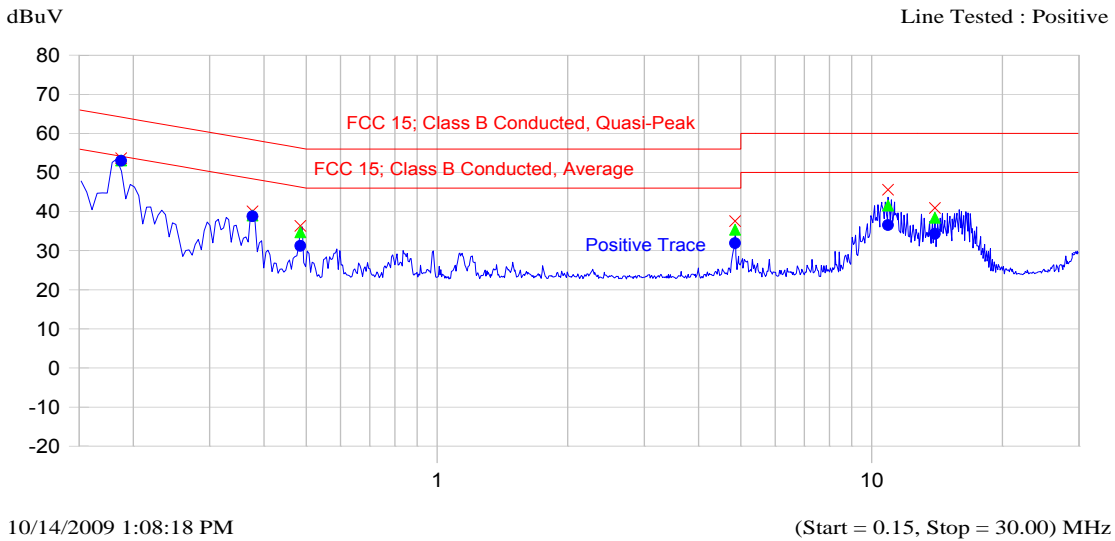

Current List

Frequency MHz	Peak dBuV	QP dBuV	Delta Qp-Qp dB	Limit dB	Avg dBuV	Delta Avg-Avg dB	Limit dB	Trace Name
0.188	53.6	53.0	-11.9		53.0	-1.9		Positive Trace
0.376	40.1	39.0	-20.5		38.8	-10.7		Positive Trace
0.485	36.3	34.7	-21.7		31.2	-15.2		Positive Trace
4.852	37.5	35.4	-20.6		31.9	-14.1		Positive Trace
10.907	45.6	41.5	-18.5		36.6	-13.4		Positive Trace
13.976	40.9	38.4	-21.6		34.3	-15.7		Positive Trace

**Plot 5.8.3.2. Power Line Conducted Emission**  
 Line Voltage: 12 VDC  
 Line Tested: Positive

**Current Graph**

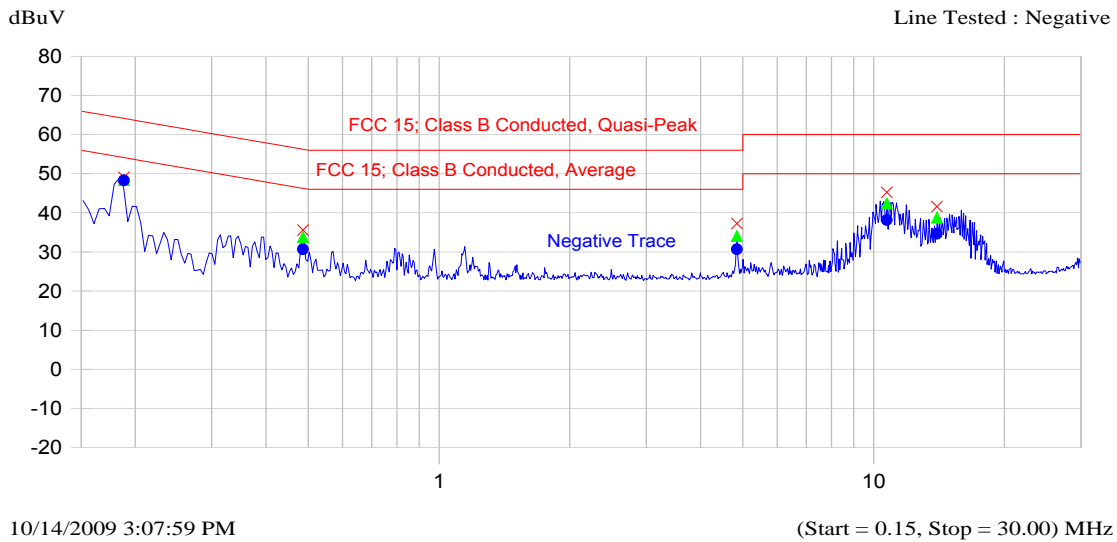

**Current List**

Frequency MHz	Peak dBuV	QP dBuV	Delta Qp-Qp dB	Limit	Avg dBuV	Delta Avg-Avg dB	Limit	Trace Name
0.188	49.1	48.4	-16.5		48.3	-6.6		Negative Trace
0.486	35.6	33.7	-22.6		30.7	-15.7		Negative Trace
4.848	37.3	34.1	-21.9		30.7	-15.3		Negative Trace
10.725	45.2	42.4	-17.6		38.2	-11.8		Negative Trace
13.979	41.6	38.8	-21.2		34.6	-15.4		Negative Trace

**EXHIBIT 6. TEST EQUIPMENT LIST**

Test Instruments	Manufacturer	Model No.	Serial No.	Operating Range
EMI Receiver System/ Spectrum Analyzer with built-in Amplifier	Hewlett Packard	HP 8546A	3520A00248	9KHz-5.6GHz, 50 Ohms
Transient Limiter	Hewlett Packard	11947A	310701998	9 kHz – 200 MHz 10 dB attenuation
L.I.S.N.	EMCO	3825/2	89071531	9 kHz – 200 MHz 50 Ohms / 50 µH
12'x16'x12' RF Shielded Chamber	RF Shielding	...	..	...
EMI-Test Receiver	Rohde & Schwarz	ESU40	100037	20 Hz- 40 GHz Build in amplifier
Spectrum Analyzer	Rohde & Schwarz	FSEK	834157/005	9 kHz- 40 GHz
Spectrum Analyzer	Hewlett Packard	HP 8593EM	3412A00103	9 kHz – 26.5 GHz
Loop Antenna	Emco	6502	2611	10 kHz – 30 MHz
Biconilog Anenna	Emco	3142	10005	26 – 3000 MHz
Biconilog Anenna	Emco	3142B	1575	26 – 2000 MHz
Log Periodic	Emco	93148	1101	0.2 – 2 GHz
Log Periodic	Emco	3148	23845	0.2 – 2 GHz
Horn Antenna	Emco	3115	6570	1 – 18 GHz
Horn Antenna	Emco	3115	5955	1 – 18 GHz
RF Amplifier	Com-Power	PA-103A	161243	10 MHz – 1000 MHz
RF Amplifier	Hewlett Packard	84498	3008A00769	1 – 26.5 GHz
Temperature & Humidity Chamber	Tenney	T5	9723B	-40°C - +80°C range

**EXHIBIT 7. MEASUREMENT UNCERTAINTY**

The measurement uncertainties stated were calculated in accordance with the requirements of NIST Technical Note 1297 and LAB 34.

**7.1. LINE CONDUCTED EMISSION MEASUREMENT UNCERTAINTY**

CONTRIBUTION (Line Conducted)	PROBABILITY DISTRIBUTION	UNCERTAINTY (dB)	
		9-150 kHz	0.15-30 MHz
EMI Receiver specification	Rectangular	$\pm 1.5$	$\pm 1.5$
LISN coupling specification	Rectangular	$\pm 1.5$	$\pm 1.5$
Cable and Input Transient Limiter calibration	Normal (k=2)	$\pm 0.3$	$\pm 0.5$
Mismatch: Receiver VRC $\Gamma_1 = 0.03$ LISN VRC $\Gamma_R = 0.8(9 \text{ kHz}) 0.2 (30 \text{ MHz})$ Uncertainty limits $20\text{Log}(1 \pm \Gamma_1 \Gamma_R)$	U-Shaped	$\pm 0.2$	$\pm 0.3$
System repeatability	Std. deviation	$\pm 0.2$	$\pm 0.05$
Repeatability of EUT	--	--	--
Combined standard uncertainty	Normal	$\pm 1.25$	$\pm 1.30$
Expanded uncertainty U	Normal (k=2)	$\pm 2.50$	$\pm 2.60$

Sample Calculation for Measurement Accuracy in 450 kHz to 30 MHz Band:

$$u_c(y) = \sqrt{\sum_{i=1}^m u_i^2(y)} = \pm \sqrt{(1.5^2 + 1.5^2)/3 + (0.5/2)^2 + (0.05/2)^2 + 0.35^2} = \pm 1.30 \text{ dB}$$

$$U = 2u_c(y) = \pm 2.6 \text{ dB}$$

**7.2. RADIATED EMISSION MEASUREMENT UNCERTAINTY**

CONTRIBUTION (Radiated Emissions)	PROBABILITY DISTRIBUTION	UNCERTAINTY (+ dB)	
		3 m	10 m
Antenna Factor Calibration	Normal (k=2)	$\pm 1.0$	$\pm 1.0$
Cable Loss Calibration	Normal (k=2)	$\pm 0.3$	$\pm 0.5$
EMI Receiver specification	Rectangular	$\pm 1.5$	$\pm 1.5$
Antenna Directivity	Rectangular	+0.5	+0.5
Antenna factor variation with height	Rectangular	$\pm 2.0$	$\pm 0.5$
Antenna phase center variation	Rectangular	0.0	$\pm 0.2$
Antenna factor frequency interpolation	Rectangular	$\pm 0.25$	$\pm 0.25$
Measurement distance variation	Rectangular	$\pm 0.6$	$\pm 0.4$
Site imperfections	Rectangular	$\pm 2.0$	$\pm 2.0$
Mismatch: Receiver VRC $\Gamma_1 = 0.2$ Antenna VRC $\Gamma_R = 0.67$ (Bi) 0.3 (Lp) Uncertainty limits $20\text{Log}(1 \pm \Gamma_1 \Gamma_R)$	U-Shaped	+1.1 -1.25	$\pm 0.5$
System repeatability	Std. Deviation	$\pm 0.5$	$\pm 0.5$
Repeatability of EUT		-	-
Combined standard uncertainty	Normal	+2.19 / -2.21	+1.74 / -1.72
Expanded uncertainty U	Normal (k=2)	+4.38 / -4.42	+3.48 / -3.44

Calculation for maximum uncertainty when 3m biconical antenna including a factor of k = 2 is used:

$U = 2u_c(y) = 2x(+2.19) = +4.38 \text{ dB}$     And     $U = 2u_c(y) = 2x(-2.21) = -4.42 \text{ dB}$