

ENGINEERING TEST REPORT

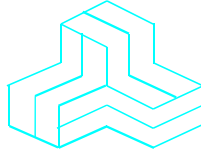

V-Station 4G
Model No.: 4GSTU1PMW

FCC ID: QC4-4GSTNP

Applicant:

Bioscrypt, Inc.
505 Cochrane Drive
Markham, Ontario
Canada L3R 8E3

In Accordance With
Federal Communications Commission (FCC)
Part 15, Subpart C, Section 15.209

UltraTech's File No.: MYT-134F15C209

This Test report is Issued under the Authority of
Tri M. Luu, Professional Engineer,
Vice President of Engineering
UltraTech Group of Labs



Date: March 31, 2009

Report Prepared by: Dharmajit Solanki

Tested by: Hung Trinh, EMC/RFI Technician

Issued Date: March 31, 2009

Test Dates: March 10 & 19, 2009

- *The results in this Test Report apply only to the sample(s) tested, and the sample tested is randomly selected.*
- *This report must not be used by the client to claim product endorsement by NVLAP or any agency of the US Government.*

UltraTech

3000 Bristol Circle, Oakville, Ontario, Canada, L6H 6G4

Tel.: (905) 829-1570 Fax.: (905) 829-8050

Website: www.ultratech-labs.com, Email: vic@ultratech-labs.com, Email: tri@ultratech-labs.com



0685



31040/SIT



C-1376



Approved Test Facility
46390-2049



200093-0



SL2-IN-E-1119R



2005-82 & 83

TABLE OF CONTENTS

EXHIBIT 1.	INTRODUCTION.....	1
1.1.	SCOPE	1
1.2.	RELATED SUBMITTAL(S)/GRANT(S)	1
1.3.	NORMATIVE REFERENCES	1
EXHIBIT 2.	PERFORMANCE ASSESSMENT.....	2
2.1.	CLIENT INFORMATION	2
2.2.	EQUIPMENT UNDER TEST (EUT) INFORMATION	2
2.3.	EUT'S TECHNICAL SPECIFICATIONS.....	3
2.4.	LIST OF EUT'S PORTS.....	3
2.5.	ANCILLARY EQUIPMENT	4
2.6.	TEST SETUP BLOCK DIAGRAM	5
EXHIBIT 3.	EUT OPERATING CONDITIONS AND CONFIGURATIONS DURING TESTS.....	7
3.1.	CLIMATE TEST CONDITIONS.....	7
3.2.	OPERATIONAL TEST CONDITIONS & ARRANGEMENT FOR TESTS.....	7
EXHIBIT 4.	SUMMARY OF TEST RESULTS	8
4.1.	LOCATION OF TESTS	8
4.2.	APPLICABILITY & SUMMARY OF EMC EMISSION TEST RESULTS	8
4.3.	MODIFICATIONS INCORPORATED IN THE EUT FOR COMPLIANCE PURPOSES.....	8
EXHIBIT 5.	MEASUREMENTS, EXAMINATIONS & TEST DATA FOR EMC EMISSIONS.....	9
5.1.	TEST PROCEDURES.....	9
5.2.	MEASUREMENT UNCERTAINTIES	9
5.3.	MEASUREMENT EQUIPMENT USED	9
5.4.	ANTENNA REQUIREMENTS [47 CFR § 15.203].....	9
5.5.	POWERLINE CONDUCTED EMISSION [47 CFR 15.207(a)].....	10
5.6.	TRANSMITTER RADIATED EMISSIONS [47 CFR §§ 15.209 & 15.205].....	15
5.7.	20 dB BANDWIDTH [47 CFR 15.209 (a)]	18
EXHIBIT 6.	TEST EQUIPMENT LIST	20
EXHIBIT 7.	MEASUREMENT UNCERTAINTY.....	21
7.1.	LINE CONDUCTED EMISSION MEASUREMENT UNCERTAINTY	21
7.2.	RADIATED EMISSION MEASUREMENT UNCERTAINTY	22

EXHIBIT 1. INTRODUCTION

1.1. SCOPE

Reference:	FCC Part 15, Subpart C
Title:	Code of Federal Regulations (CFR), Title 47, Telecommunication - Part 15
Purpose of Test:	To gain FCC Equipment Certification for section 15.209.
Test Procedures:	Both conducted and radiated emissions measurements were conducted in accordance with American National Standards Institute ANSI C63.4 - American National Standard for Methods of Measurement of Radio-Noise Emissions from Low-Voltage Electrical and Electronic Equipment in the Range of 9 kHz to 40 GHz.
Environmental Classification:	Commercial, industrial or business environment

1.2. RELATED SUBMITTAL(S)/GRANT(S)

None.

1.3. NORMATIVE REFERENCES

Publication	Year	Title
FCC 47 CFR 15	2008	Code of Federal Regulations – Telecommunication
ANSI C63.4	2003	American National Standard for Methods of Measurement of Radio-Noise Emissions from Low-Voltage Electrical and Electronic Equipment in the Range of 9 KHz to 40 GHz
CISPR 22 EN 55022	2008-09, Edition 6.0 2006	Information Technology Equipment - Radio Disturbance Characteristics - Limits and Methods of Measurement
CISPR 16-1-1 +A1 +A2	2006 2006 2007	Specification for radio disturbance and immunity measuring apparatus and methods. Part 1-1: Measuring Apparatus
CISPR 16-1-2 +A1 +A2	2003 2004 2006	Specification for radio disturbance and immunity measuring apparatus and methods. Part 1-2: Conducted disturbances

EXHIBIT 2. PERFORMANCE ASSESSMENT

2.1. CLIENT INFORMATION

APPLICANT	
Name:	Bioscrypt, Inc.
Address:	505 Cochrane Drive Markam, Ontario Canada L3R 8E3
Contact Person:	Shiraz Kapadia Phone #: 905-940-7750 Fax #: 905-940-7642 Email Address: shiraz.kapadia@bioscrypt.com

MANUFACTURER	
Name:	Knight Wah Technology Ltd.
Address:	Unit 16 - 19, 3/F Tower B, Regent Centre, 63-73 Wo Yi Hop Road, Kwai Chung, N. T. Hong Kong
Contact Person:	Y.H. Chan Phone #: (852) 2619 0162 Fax #: (852) 2619 0132 Email Address: yhchan@knightwah.com

2.2. EQUIPMENT UNDER TEST (EUT) INFORMATION

The following information (with the exception of the Date of Receipt) has been supplied by the applicant.

Brand Name:	Bioscrypt, Inc.
Product Name:	V-Station 4G
Model Name or Number:	4GSTU1PMW
Serial Number:	Test sample
Type of Equipment:	Low Power Transceiver
Input Power Supply Type:	12 VDC on DC Line or 48 VDC on PoE
Primary User Functions of EUT:	Enroll, verification, communication output

2.3. EUT'S TECHNICAL SPECIFICATIONS

TRANSMITTER	
Equipment Type:	Mobile
Intended Operating Environment:	Commercial, light industry & heavy industry
Power Supply Requirement:	4.75VDC – 16VDC
RF Output Power Rating:	63.54 dBµV/m peak at 3m distance
Operating Frequency:	125 kHz
20 dB Bandwidth:	0.478 kHz
Modulation Type:	ASK 20% duty cycle @ 100ms
Oscillator Frequencies:	125 kHz
Antenna Description:	Manufacturer: HID Type: Integrated PCB Antenna Model No.: ProxPoint 4065A OEM Freq. Range: 124.33 to 127.70 kHz

2.4. LIST OF EUT'S PORTS

Port Number	EUT's Port Description	Number of Identical Ports	Connector Type	Cable Type (Shielded/Non-shielded)
1	Ethernet 100-Base TX	1	RJ45	Non shielded
2	Host RS-485	1	Header	Non shielded
3	Host RS-232	1	Header	Non shielded
4	Power	2	Bullet and Header	Non shielded
5	Wiegand I/O (8 Lines)	1	Header	Non shielded
6	General Purpose I/O (3 Inputs & 6 Outputs)	1	Header	Non shielded
7	Relay Control (NC, NO & COM)	1	Header	Non shielded
8	USB OTG (Auxiliary Port)*	1	USB-Micro-AB	Shielded

* Note: Secured and used by service personnel only

2.5. ANCILLARY EQUIPMENT

The EUT was tested while connected to the following representative configuration of ancillary equipment necessary to exercise the ports during tests:

Ancillary Equipment # 1	
Description:	AC Adaptor
Brand Name:	Leader Electronics Inc.
Model Name or Number:	481215003CT
Serial Number:	N/A
Cable Length & Type:	< 3 m, Non-shielded
Connected to EUT's Port:	Power Connector

Ancillary Equipment # 2	
Description:	PoE Injector
Brand Name:	Allied Telesis
Model Name or Number:	AT-6101
Serial Number:	A03784G080700814A1
Cable Length & Type:	> 3 m, Non-shielded
Connected to EUT's Port:	Ethernet

2.6. TEST SETUP BLOCK DIAGRAM

2.6.1. Power Line Conducted Emission Test Setup

Test Configuration 1: External Wall Plug-in Adapter

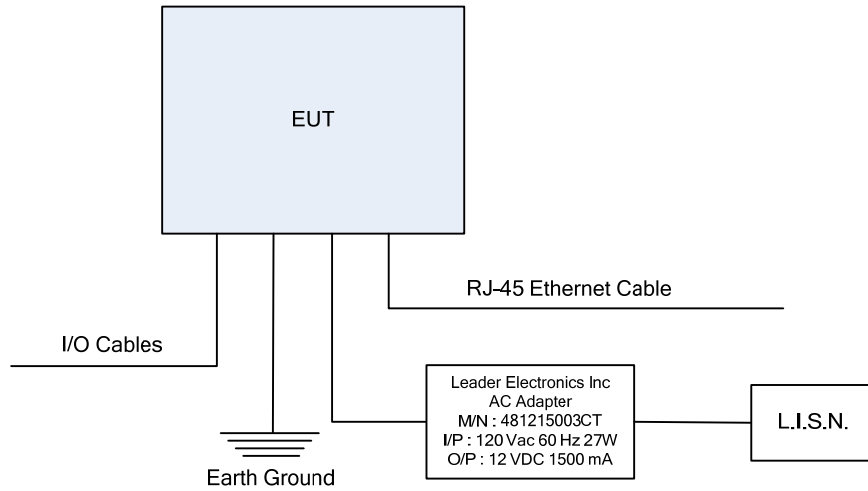

Test Configuration 2: Power Over Ethernet (PoE) Injector

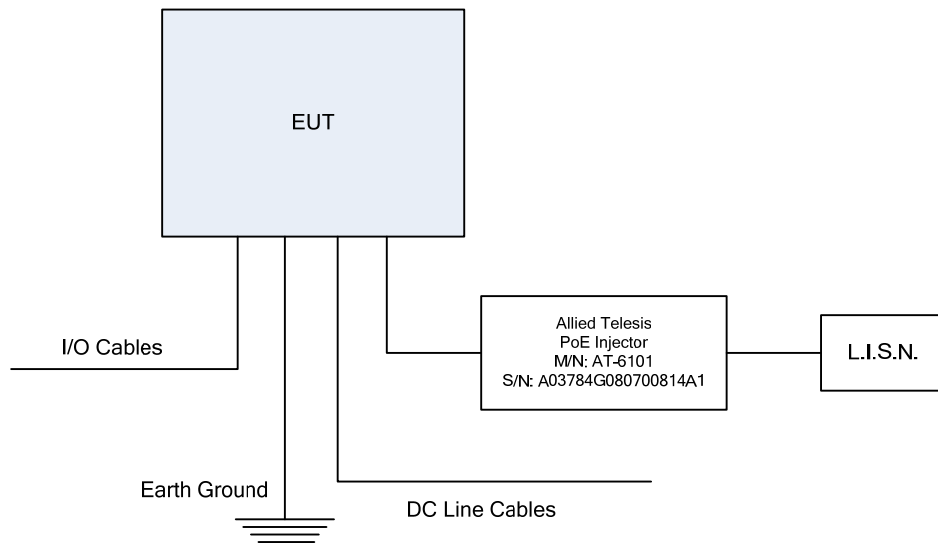

2.6.2. Radiated Emission Test Setup

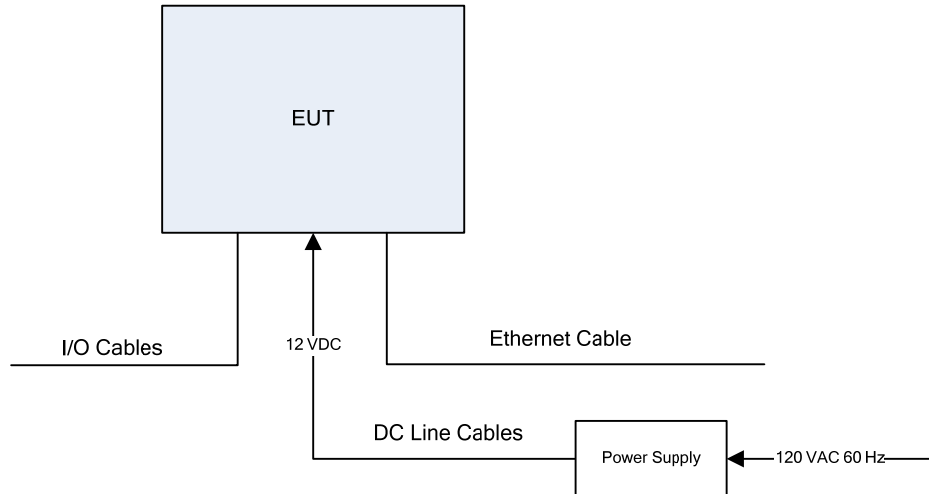

EXHIBIT 3. EUT OPERATING CONDITIONS AND CONFIGURATIONS DURING TESTS

3.1. CLIMATE TEST CONDITIONS

The climate conditions of the test environment are as follows:

Temperature:	21°C
Humidity:	51%
Pressure:	102 kPa
Power input source:	12 VDC (from AC adapter) 48 VDC (from PoE)

3.2. OPERATIONAL TEST CONDITIONS & ARRANGEMENT FOR TESTS

Operating Modes:	The EUT was configured for continuous transmission for the duration of testing.
Special Test Software:	N/A
Special Hardware Used:	N/A
Transmitter Test Antenna:	The EUT was tested with the antenna fitted in a manner typical of normal intended use as integral antenna equipment.

Transmitter Test Signals	
Frequency Band(s):	125 kHz
Test Frequency(ies):	125 kHz
RF Power Output:	63.54 dB μ V/m peak at 3m distance
Normal Test Modulation:	ASK
Modulating Signal Source:	Internal

EXHIBIT 4. SUMMARY OF TEST RESULTS

4.1. LOCATION OF TESTS

All of the measurements described in this report were performed at Ultratech Group of Labs located in the city of Oakville, Province of Ontario, Canada.

- AC Power Line Conducted Emissions were performed in UltraTech's shielded room, 24'(L) by 16'(W) by 8'(H).
- Radiated Emissions were performed at the Ultratech's 3-10 TDK Semi-Anechoic Chamber situated in the Town of Oakville, province of Ontario. This test site been calibrated in accordance with ANSI C63.4, and found to be in compliance with the requirements of Sec. 2.948 of the FCC Rules. The descriptions and site measurement data of the Oakville 3-10 TDK Semi-Anechoic Chamber has been filed with FCC office (FCC File No.: 31040/SIT 1300B3) and Industry Canada office (Industry Canada File No.: 2049A-3). Expiry Date of Site Calibration: May 17, 2009.

4.2. APPLICABILITY & SUMMARY OF EMC EMISSION TEST RESULTS

FCC Section(s)	Test Requirements	Compliance (Yes/No)
15.203	Antenna Requirement	Yes
15.207(a)	Power Line Conducted Emissions	Yes
15.209(a)	20 dB Bandwidth	Yes
15.209	Transmitter Radiated Emissions - Fundamental, Harmonic and Spurious Emissions	Yes

4.3. MODIFICATIONS INCORPORATED IN THE EUT FOR COMPLIANCE PURPOSES

The following modifications were made for compliance:

- 1) V-Station 4G required the addition of a Steward Ferrite P/N: 28A4155-0A2, requiring 1/2 turn on the IO and Power lines close to the unit power and IO port.
- 2) V-Station 4G required the addition of a Steward Ferrite P/N: 28A2432-0A2, requiring 1/2 turn on the Ethernet lines close to the unit RJ45 port.
- 3) V-Station 4G also required the addition of two Steward Ferrites, P/N: 28B0562-000, and each ferrite required 1 ½ turns on the internal LVDs cable. One ferrite close to one end of the LVDs cable and another ferrite close to other end of the LVDs cable.

EXHIBIT 5. MEASUREMENTS, EXAMINATIONS & TEST DATA FOR EMC EMISSIONS

5.1. TEST PROCEDURES

This section contains test results only. Details of test methods and procedures can be found in ANSI C63.4 and Ultratech's test procedures ULTR-P001-2004.

5.2. MEASUREMENT UNCERTAINTIES

The measurement uncertainties stated were calculated in accordance with requirements of UKAS Document LAB 34 with a confidence level of 95%. Please refer to Exhibit 7 for Measurement Uncertainties.

5.3. MEASUREMENT EQUIPMENT USED

The measurement equipment used complied with the requirements of the Standards referenced in the Methods & Procedures ANSI C63.4 and CISPR 16-1-1.

5.4. ANTENNA REQUIREMENTS [47 CFR § 15.203]

5.4.1. Requirements

An intentional radiator shall be designed to ensure that no antenna other than that furnished by the responsible party shall be used with the device.

Notes: This requirement does not apply to carrier current devices operated under the provisions of @ 15.211, 15.213, 15.217, 17.219 or 15.221.

5.4.2. Engineering Analysis

The antenna is an integral part of the EUT; it is soldered onto the radio printed circuit board and located inside the enclosure.

5.5. POWERLINE CONDUCTED EMISSION [47 CFR 15.207(a)]

5.5.1. Limit(s)

The equipment shall meet the limits of the following table:

Frequency of emission (MHz)	Conducted Limits (dB μ V)	
	Quasi-peak	Average
0.15–0.5	66 to 56*	56 to 46*
0.5–5	56	46
5–30	60	50

*Decreases linearly with the logarithm of the frequency

5.5.2. Method of Measurements

Refer to ANSI C63.4.

5.5.3. Test Data

Plot 5.5.3.1 Power Line Conducted Emission
Test Configuration 1: External Wall Plug-in Adapter
Line Voltage: 120VAC 60Hz
Line Tested: Hot

Setup Name: FCC 15 Class B
Customer Name: Bioscrypt Inc
Project Number: MYT-134Q
Operator Name: Nimisha
EUT Name: V-Station Prox WiFi(Sensor :UPEK TCS1) (Model Name:U-Station4G(u1,H),Model No:4GSTu1HW)
Date Created: 3/10/2009 4:31:22 PM
Date Modified: 3/10/2009 4:47:00 PM

Current Graph

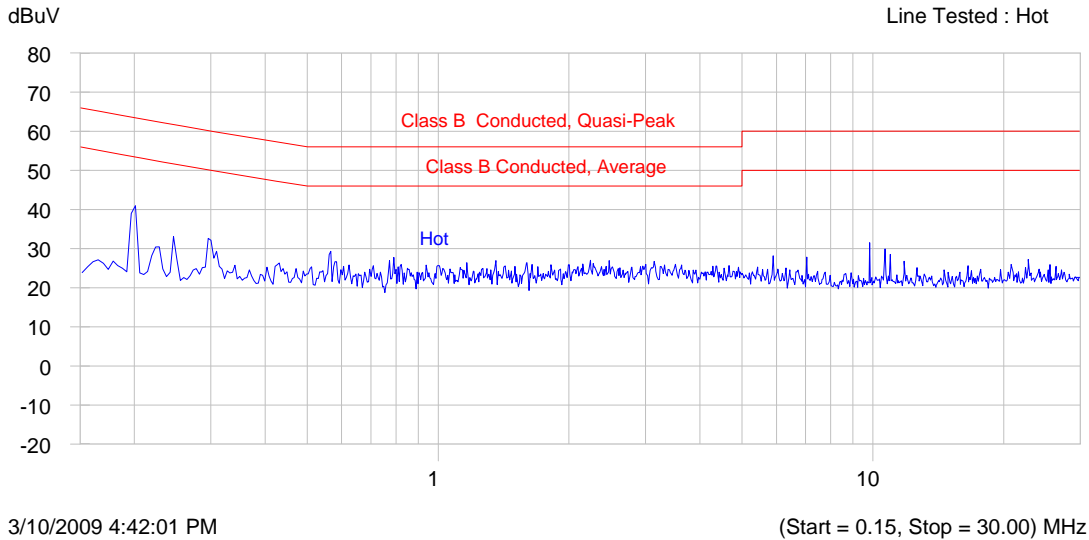

Current List

Frequency MHz	Peak dBuV	QP dBuV	Delta Qp-Qp Limit dB	Avg dBuV	Delta Avg-Avg Limit dB	Trace Name
0.197	44.1	36.2	-27.6	16.0	-37.7	Hot Trace
0.286	38.6	29.4	-31.2	15.8	-34.9	Hot Trace
9.830	34.1	31.2	-28.8	26.5	-23.5	Hot Trace
10.659	32.9	29.0	-31.0	24.2	-25.8	Hot Trace

Plot 5.5.3.2 Power Line Conducted Emission
 Test Configuration 1: External Wall Plug-in Adapter
 Line Voltage: 120VAC 60Hz
 Line Tested: Neutral

Setup Name: FCC 15 Class B
 Customer Name: Bioscrypt Inc
 Project Number: MYT-134Q
 Operator Name: Nimisha
 EUT Name: V-Station Prox WiFi(Sensor :UPEK TCS1) (Model Name:U-Station4G(u1,H),Model No:4GSTu1HW)
 Date Created: 3/10/2009 4:31:22 PM
 Date Modified: 3/10/2009 4:54:02 PM

Current Graph

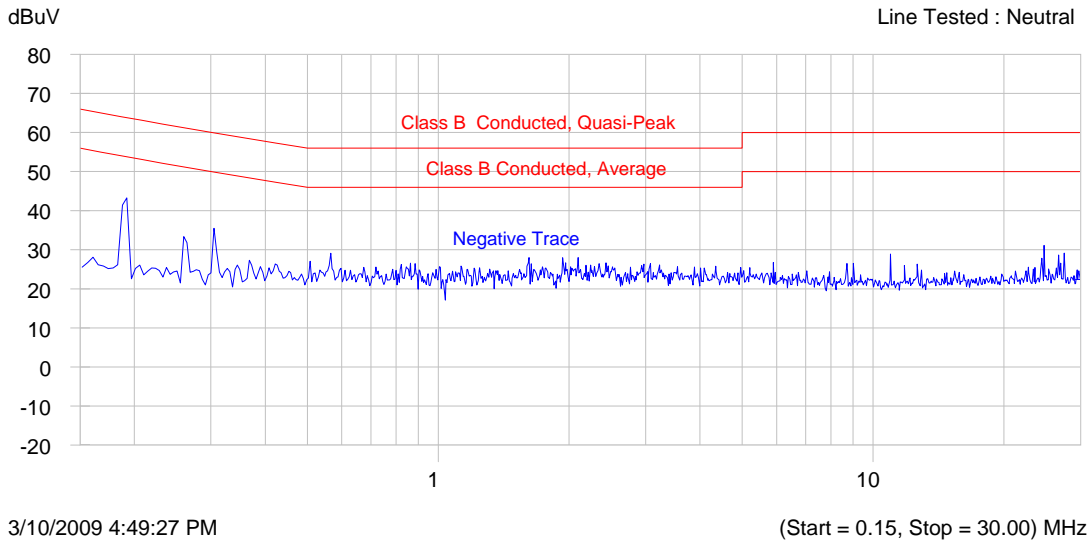

Current List

Frequency MHz	Peak dBuV	QP dBuV	Delta Qp-Qp Limit dB	Avg dBuV	Delta Avg-Avg Limit dB	Trace Name
0.174	48.1	39.3	-25.5	15.1	-39.6	Neutral Trace
0.289	37.7	29.5	-31.1	15.7	-34.9	Neutral Trace
10.963	28.7	27.4	-32.6	22.8	-27.2	Neutral Trace
24.722	29.0	25.9	-34.1	21.4	-28.6	Neutral Trace

Plot 5.5.3.3 Power Line Conducted Emission
Test Configuration 2: Power over Ethernet (PoE) Injector
Line Voltage: 120VAC 60Hz
Line Tested: Hot

Setup Name: FCC 15 Class B
Customer Name: Bioscrypt Inc
Project Number: MYT-134Q
Operator Name: Nimisha
EUT Name: V-Station Prox WiFi(Sensor :UPEK TCS1Model Name:U-Station4G(u1,H),Model No:4GSTu1HW)
Date Created: 3/10/2009 12:57:15 PM
Date Modified: 3/10/2009 1:44:07 PM

Current Graph

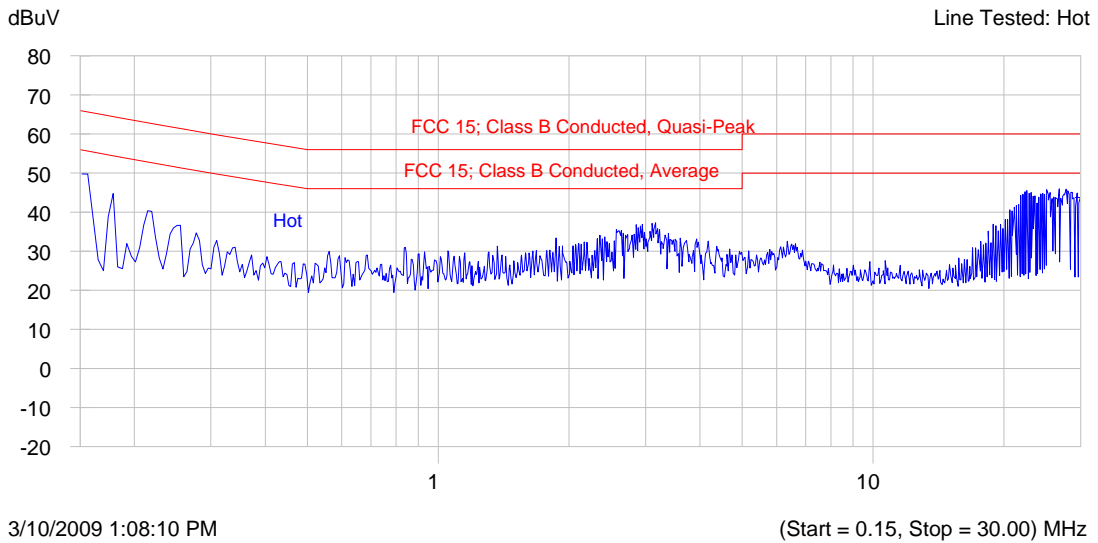

Current List

Frequency MHz	Peak dBuV	QP dBuV	Delta QP-QP Limit dB	Avg dBuV	Delta Avg-Avg Limit dB	Trace Name
0.160	51.6	43.0	-22.4	26.8	-28.7	Hot Trace
0.217	44.4	39.8	-23.1	25.5	-27.4	Hot Trace
2.944	37.8	35.8	-20.2	33.7	-12.3	Hot Trace
22.580	25.9	22.4	-37.6	15.9	-34.1	Hot Trace
26.814	43.7	33.6	-26.4	9.9	-40.1	Hot Trace

Plot 5.5.3.4 Power Line Conducted Emission
Test Configuration 2: Power over Ethernet (PoE) Injector
Line Voltage: 120VAC 60Hz
Line Tested: Neutral

Setup Name: FCC 15 Class B
Customer Name: Bioscrypt Inc
Project Number: MYT-134Q
Operator Name: Nimisha
EUT Name: V-Station Prox WiFi(Sensor :UPEK TCS1) (Model Name:U-Station4G(u1,H),Model No:4GSTu1HW)
Date Created: 3/10/2009 12:57:15 PM
Date Modified: 3/10/2009 1:54:32 PM

Current Graph

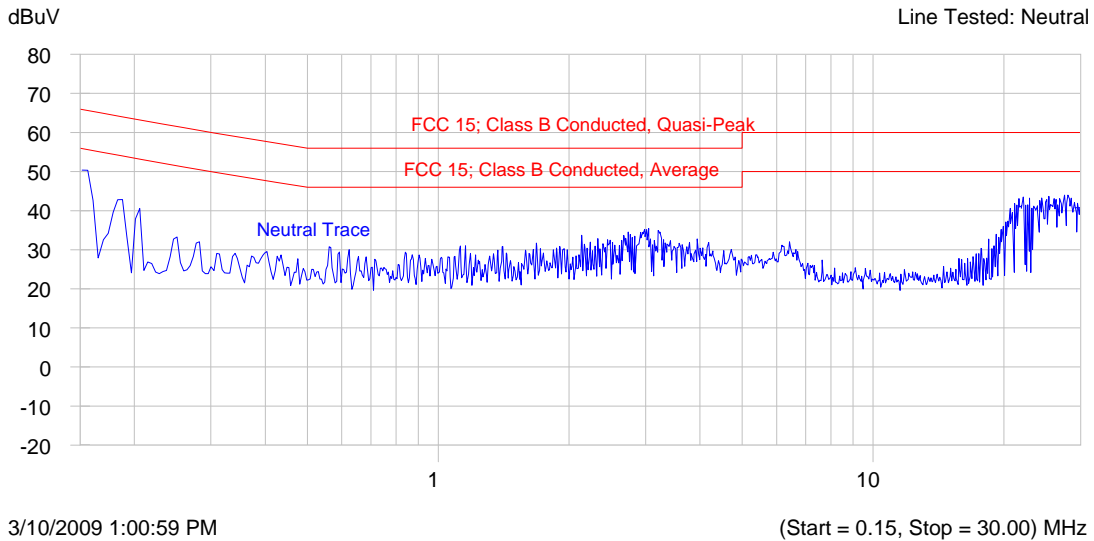

Current List

Frequency MHz	Peak dBuV	QP dBuV	Delta QP-QP Limit dB	Avg dBuV	Delta Avg-Avg Limit dB	Trace Name
0.187	48.6	43.7	-20.4	28.3	-25.8	Neutral Trace
0.195	45.7	36.4	-27.5	16.5	-37.3	Neutral Trace
2.142	34.5	32.0	-24.0	29.8	-16.2	Neutral Trace
3.041	36.9	34.5	-21.5	31.1	-14.9	Neutral Trace
22.149	44.6	36.0	-24.0	10.2	-39.8	Neutral Trace

5.6. TRANSMITTER RADIATED EMISSIONS [47 CFR §§ 15.209 & 15.205]

5.6.1. Limit(s)

§ 15.209:

(a) The emissions from an intentional radiator shall not exceed the field strength levels specified in the following table:

47 CFR 15.209(a) General Field Strength Limits

Frequency (MHz)	Field Strength (microvolts/meter)	Measurement Distance (meters)
0.009 - 0.490	2400/F(kHz)	300
0.490 - 1.705	24000/F(kHz)	30
1.705 - 30.0	30	30
30 – 88	100 **	3
88 – 216	150 **	3
216 – 960	200 **	3
Above 960	500	3

** Except as provided in paragraph (g), fundamental emissions from intentional radiators operating under this Section shall not be located in the frequency bands 54-72 MHz, 76-88 MHz, 174-216 MHz or 470-806 MHz. However, operation within these frequency bands is permitted under other sections of this Part, e.g., Sections 15.231 and 15.241.

- (b) In the emission table above, the tighter limit applies at the band edges.
- (c) The level of any unwanted emissions from an intentional radiator operating under these general provisions shall not exceed the level of the fundamental emission. For intentional radiators which operate under the provisions of other Sections within this Part and which are required to reduce their unwanted emissions to the limits specified in this table, the limits in this table are based on the frequency of the unwanted emission and not the fundamental frequency. However, the level of any unwanted emissions shall not exceed the level of the fundamental frequency.
- (d) The emission limits shown in the above table are based on measurements employing a CISPR quasi-peak detector except for the frequency bands 9–90 kHz, 110–490 kHz and above 1000 MHz. Radiated emission limits in these three bands are based on measurements employing an average detector.
- (e) The provisions in Sections 15.31, 15.33, and 15.35 for measuring emissions at distances other than the distances specified in the above table, determining the frequency range over which radiated emissions are to be measured, and limiting peak emissions apply to all devices operated under this Part.
- (f) In accordance with Section 15.33(a), in some cases the emissions from an intentional radiator must be measured to beyond the tenth harmonic of the highest fundamental frequency designed to be emitted by the intentional radiator because of the incorporation of a digital device. If measurements above the tenth harmonic are so required, the radiated emissions above the tenth harmonic shall comply with the general radiated emission limits applicable to the incorporated digital device, as shown in Section 15.109 and as based on the frequency of the emission being measured, or, except for emissions contained in the restricted frequency bands shown in Section 15.205, the limit on spurious emissions specified for the intentional radiator, whichever is the higher limit. Emissions which must be measured above the tenth harmonic of the highest fundamental frequency designed to be emitted by the intentional radiator and which fall within the restricted bands shall comply with the general radiated emission limits in Section 15.109 that are applicable to the incorporated digital device.

(g) Perimeter protection systems may operate in the 54-72 MHz and 76-88 MHz bands under the provisions of this section. The use of such perimeter protection systems is limited to industrial, business and commercial applications.

5.6.2. Method of Measurements

Ultratech Test Procedures, File # ULTR P001-2004 and ANSI C63.4 for measurement methods.

5.6.3. Test Data

Remarks:

- The measuring receiver shall be tuned over the frequency range 9 kHz to 1 GHz.
- All spurious emissions that are in excess of 20 dB below the specified limit shall be recorded.
- EUT was initially tested a 10m, signal was not detected at this distance, and test distance was reduced to 3m. The value measured at 3m shall be extrapolated as applicable to compare with limit and measurement distance specified in section 15.209(a).
- Extrapolation factor of 40dB/decade shall be used for frequencies below 30 MHz.

5.6.3.1. Fundamental Emissions

<p>Remarks:</p> <ul style="list-style-type: none"> • Field strength limit of the fundamental 125 kHz at 300m distance is $20 \cdot \log(2400/125) = 25.7$ dBμV/m • For frequency band 0.009- 0.490 MHz, the measured E-Field at 3m (column 2) will be extrapolated to 300m E-Field Level (column 3) using the extrapolation factor of $40 \cdot \log(3/300) = -80$ dB 					
Frequency (MHz)	Peak E-Field @ 3m (dB μ V/m)	Extrapolated E-Field Level @ 300m (dB μ V/m)	Antenna Plane (H/V)	§ 15.209 (a) Limits @ 300m (dB μ V/m)	Margin (dB)
0.125	63.54	-16.46	V	25.7	-42.2
0.125	59.37	-20.63	H	25.7	-46.3

5.6.3.2. Harmonic/Spurious Emissions

Remarks:

- For frequency band 0.009- 0.490 MHz, the measured E-Field at 3m (column 2) will be extrapolated to 300m E-Field Level (column 3) using the extrapolation factor of $40 \cdot \log(3/300) = -80$ dB
- For frequency bands 0.490-1.705 MHz and 1.705-30.0 MHz, the measured E-Field at 3m (column 2) will be extrapolated to 30m E-Field Level (column 3) using the extrapolation factor of $40 \cdot \log(3/30) = -40$ dB

Frequency (MHz)	Peak E-Field @ 3m (dBµV/m)	Extrapolated E-Field Level (dBµV/m)	Antenna Plane (H/V)	§ 15.209 (a) Limits (dBµV/m)	Margin (dB)
0.009 - 0.490	*	*	H / V	48.5 to 13.8	*
0.490 - 1.705	*	*	H / V	33.8 to 23.0	*
1.705 - 30.0	*	*	H / V	29.5	*
30 - 88	*	*	H / V	40.0	*
88 - 216	*	*	H / V	43.5	*
216 - 960	*	*	H / V	46.0	*
960 - 1000	*	*	H / V	54.0	*

* No emission found.

5.7. 20 dB BANDWIDTH [47 CFR 15.209 (a)]

5.7.1. Limit(s)

Emission bandwidth shall not be located in the restricted bands in 15.205 and the frequency bands 54-72 MHz, 76-88 MHz, 174-216 MHz or 470-806 MHz.

5.7.2. Method of Measurements

The measurements were performed in accordance with Ultratech Test Procedures, File # ULTR P001-2004 and ANSI C63.4:2003.

The transmitter output was loosely coupled to the spectrum analyzer through a receiving antenna. The bandwidth of the fundamental frequency was measured with the spectrum analyzer, with the resolution BW set to 1% to 3 % of the approximate emission width and video BW set to 3 times the resolution BW.

5.7.3. Test Data

Channel Frequency (MHz)	20 dB Bandwidth (kHz)
125 kHz	0.478

See the following plot for details.

Plot 5.7.3.1: 20 dB Bandwidth
Fc: 125 kHz

Meas Type 20dB Bandwidth
Equipment under Test V-Station 4G(U1.P), Model: 4GSTU1PW
Manufacturer Bioscrypt Inc.
OP Condition 125 kHz
Operator Hung Trinh
Test Spec
FCC 15.209 & ETSI 300 330

Sweep Settings Screen A

Center Frequency	125.493590 kHz	Ref Level	80.000 dBµV/m
Frequency Offset	0.000000 Hz	Ref Level Offset	0.000 dB
Span	1.000000 kHz	Ref Position	100.000 %
Start Frequency	124.993590 kHz	Level Range	100.000 dB
Stop Frequency	125.993590 kHz	RF Att	10.000 dB
RBW	100.000000 Hz		
VBW	100.000000 Hz	X-Axis	LIN
Sweep Time	10.00 s	Y-Axis	LOG

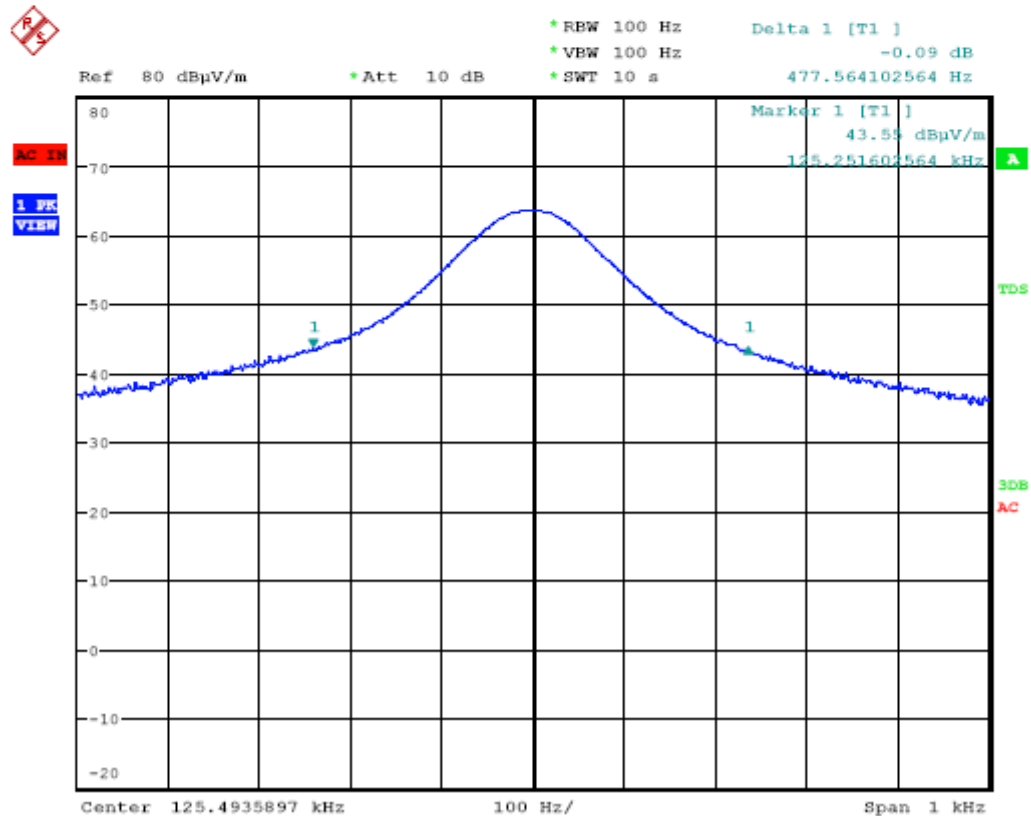

EXHIBIT 6. TEST EQUIPMENT LIST

Test Instruments	Manufacturer	Model No.	Serial No.	Operating Range
EMI Receiver System/ Spectrum Analyzer with built-in Amplifier	Hewlett Packard	HP 8546A	3520A00248	9KHz-5.6GHz, 50 Ohms
Transient Limiter	Hewlett Packard	11947A	310701998	9 kHz – 200 MHz 10 dB attenuation
L.I.S.N.	EMCO	3825/2	89071531	9 kHz – 200 MHz 50 Ohms / 50 µH
12'x16'x12' RF Shielded Chamber	RF Shielding
EMI-Test Receiver	Rohde & Schwarz	ESU40	100037	20 Hz- 40 GHz Build in amplifier
Spectrum Analyzer	Rohde & Schwarz	FSEK30	100077	20 Hz- 40 GHz
Loop Antenna	Emco	6502	2611	10 kHz – 30 MHz
Biconilog Anenna	Emco	3142	10005	26 – 3000 MHz
Biconilog Anenna	Emco	3142B	1575	26 – 2000 MHz
Log Periodic	Emco	93148	1101	0.2 – 2 GHz
Log Periodic	Emco	3148	23845	0.2 – 2 GHz
Horn Antenna	Emco	3115	6570	1 – 18 GHz
Horn Antenna	Emco	3115	5955	1 – 18 GHz
RF Amplifier	Com-Power	PA-103A	161243	10 MHz – 1000 MHz
RF Amplifier	Hewlett Packard	84498	3008A00769	1 – 26.5 GHz
Temperature & Humidity Chamber	Tenney	T5	9723B	-40°C - +80°C range

ULTRATECH GROUP OF LABS

3000 Bristol Circle, Oakville, Ontario, Canada L6H 6G4
Tel. #: 905-829-1570, Fax. #: 905-829-8050, Email: vic@ultratech-labs.com, Website: http://www.ultratech-labs.com

File #: MYT-134F15C209
March 31, 2009

All test results contained in this engineering test report are traceable to National Institute of Standards and Technology (NIST)

EXHIBIT 7. MEASUREMENT UNCERTAINTY

The measurement uncertainties stated were calculated in accordance with the requirements of NIST Technical Note 1297 and LAB 34

7.1. LINE CONDUCTED EMISSION MEASUREMENT UNCERTAINTY

CONTRIBUTION (Line Conducted)	PROBABILITY DISTRIBUTION	UNCERTAINTY (dB)	
		9-150 kHz	0.15-30 MHz
EMI Receiver specification	Rectangular	± 1.5	± 1.5
LISN coupling specification	Rectangular	± 1.5	± 1.5
Cable and Input Transient Limiter calibration	Normal (k=2)	± 0.3	± 0.5
Mismatch: Receiver VRC $\Gamma_1 = 0.03$ LISN VRC $\Gamma_R = 0.8(9 \text{ kHz}) 0.2 (30 \text{ MHz})$ Uncertainty limits $20\text{Log}(1 \pm \Gamma_1 \Gamma_R)$	U-Shaped	± 0.2	± 0.3
System repeatability	Std. deviation	± 0.2	± 0.05
Repeatability of EUT	--	--	--
Combined standard uncertainty	Normal	± 1.25	± 1.30
Expanded uncertainty U	Normal (k=2)	± 2.50	± 2.60

Sample Calculation for Measurement Accuracy in 450 kHz to 30 MHz Band:

$$u_c(y) = \sqrt{\sum_{i=1}^m u_i^2(y)} = \pm \sqrt{(1.5^2 + 1.5^2)/3 + (0.5/2)^2 + (0.05/2)^2 + 0.35^2} = \pm 1.30 \text{ dB}$$

$$U = 2u_c(y) = \pm 2.6 \text{ dB}$$

7.2. RADIATED EMISSION MEASUREMENT UNCERTAINTY

CONTRIBUTION (Radiated Emissions)	PROBABILITY DISTRIBUTION	UNCERTAINTY (\pm dB)	
		3 m	10 m
Antenna Factor Calibration	Normal (k=2)	± 1.0	± 1.0
Cable Loss Calibration	Normal (k=2)	± 0.3	± 0.5
EMI Receiver specification	Rectangular	± 1.5	± 1.5
Antenna Directivity	Rectangular	+0.5	+0.5
Antenna factor variation with height	Rectangular	± 2.0	± 0.5
Antenna phase center variation	Rectangular	0.0	± 0.2
Antenna factor frequency interpolation	Rectangular	± 0.25	± 0.25
Measurement distance variation	Rectangular	± 0.6	± 0.4
Site imperfections	Rectangular	± 2.0	± 2.0
Mismatch: Receiver VRC $\Gamma_1 = 0.2$ Antenna VRC $\Gamma_R = 0.67$ (Bi) 0.3 (Lp) Uncertainty limits $20\text{Log}(1+\Gamma_1\Gamma_R)$	U-Shaped	+1.1 -1.25	± 0.5
System repeatability	Std. Deviation	± 0.5	± 0.5
Repeatability of EUT		-	-
Combined standard uncertainty	Normal	+2.19 / -2.21	+1.74 / -1.72
Expanded uncertainty U	Normal (k=2)	+4.38 / -4.42	+3.48 / -3.44

Calculation for maximum uncertainty when 3m biconical antenna including a factor of k = 2 is used:

$U = 2u_c(y) = 2x(+2.19) = +4.38 \text{ dB}$ And $U = 2u_c(y) = 2x(-2.21) = -4.42 \text{ dB}$