

DASTEK EMC Lab

204, Chuge-Ri, Yangji-Myeon, Yongin -Shi, Kyunggi-Do, Korea

Tel : 82-31-335-9341 Fax : 82-31-335-9343

Verificate of Compliance

APPLICANT : **DiVACESS Inc.**
EUT Type : **USB TV RECEIVER**
Model Name : **Real USB-TV**
Serial No : **100007**
Manufacturer Name : **DiVACESS Inc.**
Address & Country : **10th, Happy World B/D., 917-6, Mok 1-dong,
Yangcheon-gu, Seoul, 158-721, Korea**
Rule Part(s): : **FCC 15 Subpart B**
Equipment Class : **Class B**

This device has been shown to be capable of compliance with the applicable technical standard as indicated in the measurement report and was tested in accordance with the measurement procedures specified in ANSI C63.4-1992 with the following remarks

(Note codes): (#37)

I attest to the accuracy of data and all measurements reported herein were performed by me or were made under my supervision and are correct to the best of my knowledge and belief. I assume full responsibility for the completeness of these measurements and vouch for the qualifications of all persons taking them.

Report No: DAC02-K0184

Issued Date : March 16, 2002

In-Young, Chung.

Manager EMC Dept

Jun-Ho, Choi.

Test Engineer



Table of Contents

Scope	3
Introduction (Site Description)	4
Product Information	5
Description of Test (Radiated & Conducted)	6-7
List of Support Equipment	8
Test Result(Radiated & Conducted)	9-10
Test Data (Radiated & Conducted)	11-12
Sample Calculations	13
List of Test Equipment	14
Appendix A - Labeling Requirements	15
Appendix B - Block Diagram / Schematics	16
Appendix C - Photographs of Test Set-up (Line Conducted and Radiated Test Pictures)	17-18
Appendix D - EUT Photographs	19-20
Appendix E – User’s Manual	21

Scope

Measurement and determination of electromagnetic emissions (EMI) of radio frequency devices including intentional and/or unintentional radiators for compliance with the technical rules and regulations of the Federal Communications Commission.

**Company Name : DiVACCESS Inc.
10th, Happy World B/D., 917-6,
Mok 1-dong, Yangcheon-gu, Seoul,
158-721, Korea**

FCC ID: : -
Class: : **Class B**
EUT Type : **USB TV RECEIVER**
Model Name : **Real USB-TV**
Trade Name : **DiVACCESS Inc..**
Rule Part(s) : **FCC Part 15 Subpart B**
Test Procedure : **ANSI C-63.4 (1992)**
Date of Test(s) : **March 16, 2002**
Place of Tests : **Dastek EMC Lab, in Korea.**
Test Report No : **DAC02-K0184**

Introduction

These measurement tests were conducted at *Dastek EMC Laboratory* facility in Korea. The site address is 204 Chege-Ri, Yangji-Myeon, Yongin-City, Kunggi-Do, Korea. *Dastek EMC Laboratory* is a company that has started the July of 1981, for manufacturing of EMI noise filters and EMI Test and diverging service.

The area of test site is located at 54 Kilometers (33miles) southeast from seoul International Airport, 42 Kilometers (26miles) south-southeast from central seoul where ambient radio signal conditions are quiet and a favorable area to measure the radio frequency interference on open field test site for the computing devices manufacturers.

The detailed description of the measurement facility was found to be in compliance with the requirements of section 2.948 according to ANSI C63.4 on November 02, 2000(Registration Number:90547).



Product Information

Equipment Description

The Equipment under Test (EUT) is the USB TV RECEIVER of DiVACCESS Inc.

Model Name: Real USB-TV

Serial Number : 100007

1. Specification

See the manual

Description of Tests

Conducted Emissions

The line conducted facility is located inside a 4.6(m)x6.5(m)x2.5(m) shielded room.

A wooden table 80cm high is located on one side of the shielded room; desktop EUTs are placed on top of this table.

The rear of the EUT is placed a minimum of 40cm from the shielded room wall.

The side of the EUT is 1m from the LISN, which is bonded to the shielded room wall via a 1-foot wide bonding strap.

The LISN is isolated from the other filtered power via an additional filter to ensure that RFI from the auxiliary instrumentation (scopes, etc.) does not influence the readings.

The excess power cord from the EUT is folded back and forth to form a 30-40cm non-inductive bundle. All interconnecting cables more than 1 meter were shortened by non-inductive bundling (serpentine fashion) to a 1 meter length.

Sufficient time for the EUT, support equipment, and test equipment was allowed in order for them to warm up to their normal operating condition.

The RF output of the LISN was connected to the spectrum analyzer to determine the frequency producing the maximum EMI from the EUT.

The spectrum was scanned from 450KHz to 30MHz with 20 msec sweep time.

The frequency producing the maximum level was reexamined using Quasi-Peak adapter.

The detector function was set to CISPR quasi-peak mode.

The bandwidth of the receiver was set to 9KHz.

The EUT, support equipment, and interconnecting cables were arranged and manipulated to maximize each EMI emission.

Each emission was maximized by: switching power lines, varying the mode of operation or resolution, clock or data exchange speed, scrolling H pattern to the EUT and/or support equipment, and powering the monitor from the floor mounted outlet box and the computer aux AC outlet, if applicable; whichever determined the worst-case emission.

Photographs of the worst-case emission can be seen in Appendix C.

Radiated Emissions

Preliminary measurements were made indoors at 1 meter using broadband antennas, broadband amplifier, and spectrum analyzer to determine the frequency producing the maximum EMI.

Appropriate precaution was taken to ensure that all EMI from the EUT were maximized and investigated. The system configurations, clock speed, mode of operation or video resolution, turntable azimuth with respect to the antenna were noted for each

Frequency found. The spectrum was scanned from 30 to 200 MHz using biconical antenna and 200 to 1000 MHz using log-periodic antenna.

Final measurements were made outdoors at 10-meter test range using biconical and log periodic antennas. The test equipment was placed on a wooden and plastic bench situated on a 1.5 x 2-meter area adjacent to the measurement area. Sufficient time for the EUT, support equipment, and test equipment was allowed in order for them to warm up to their normal operating condition. Each frequency found during pre-scan measurements was re-examined and investigated using Quasi Peak Adapter. The detector function was set to CISPR quasi peak mode and the bandwidth of the receiver was set to 100KHz or 1MHz depending on the frequency or type of signal.

The antenna was turned to the frequency found during preliminary radiated measurements. The EUT, support equipment and interconnecting cables were reconfigured to the set-up producing the maximum emission for the frequency and were placed on top of a 0.8 meter high nonmetallic 1 x 1.5 meter table. The EUT, support equipment, and interconnecting cables were re-arranged and manipulated to maximize each EMI emission. The turntable containing the system was rotated: the antenna height was varied 1 to 4 meters and stopped at the azimuth or height producing the maximum emission. Each emission was maximized by: varying the mode of operation or resolution; clock or data exchange speed; scrolling H pattern to the EUT and/or support equipment, and powering the monitor from the floor mounted outlet box and the computer aux AC outlet, if applicable; and changing the polarity of the antenna, whichever determined the worst-case emission. Photographs of the worst-case emission can be seen in Appendix C.

Support Equipment Used



D A S T E K E M C L a b , 204 Chuge-Ri Yangji-Myeon Yongin-Shi Kyunggi-Do, Korea

Tel: 82-31-335-9341 Fax: 82-31-335-9343

MONITOR	CPG17P(T)	P060H2JKA01862	ACCENT	
PRINTER	2225C	3121S96895	H.P	
KEYBOARD	ACK-280	9100667954	Solid year co., Ltd.	
MOUSE	P801	35461	KYE SYSTEMS	
MOUSE	OK-720	N/A	A-FOUR TECH	
USB TV RECEIVER	Real USB-TV	100007	DiVACCESS Inc./Korea	EUT

Distance : 3.0m

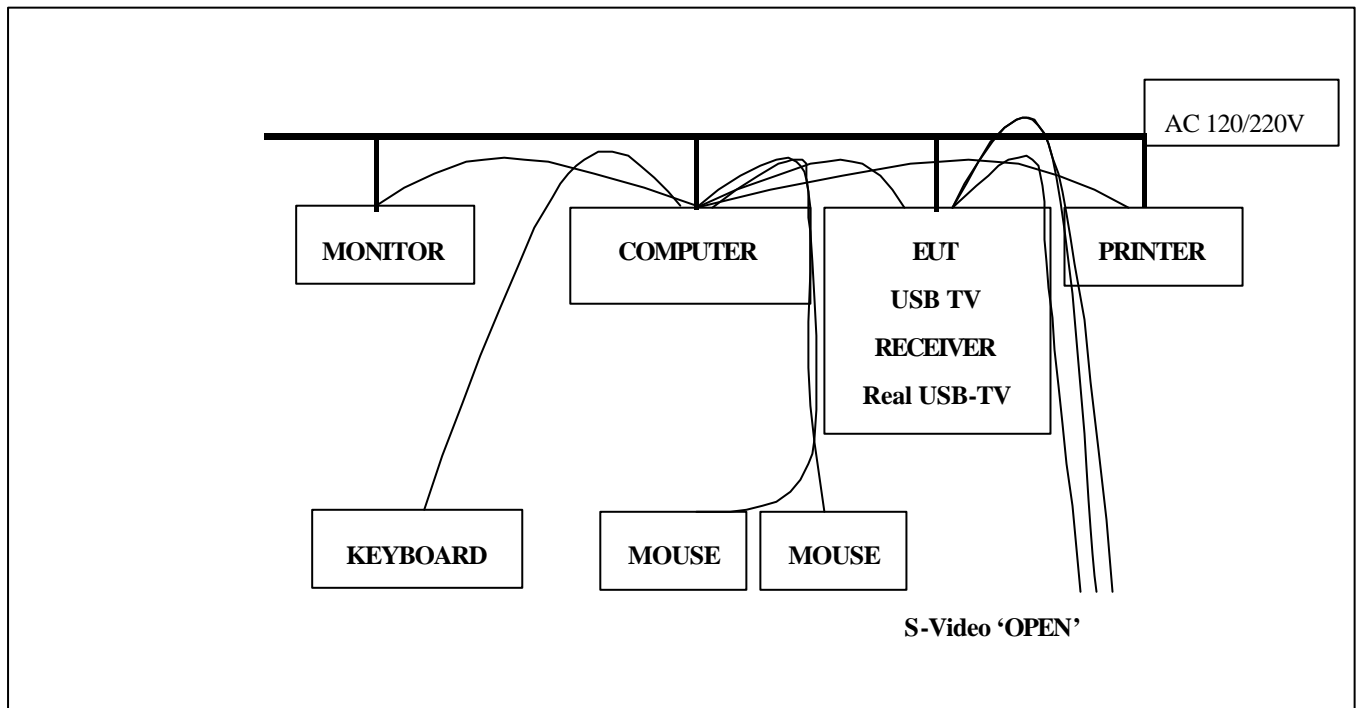

Test Result



DASTEK EMC Lab, 204 Chuge-Ri Yangji-Myeon Yongin-Shi Kyunggi-Do, Korea

Tel: 82-31-335-9341 Fax: 82-31-335-9343

Conducted Emission

Frequency(MHz)	Level(dBuV)	Lines	Factor	Limit(dBuV)	Margin(dBuV)
0.45	28.10	N	-	48.00	19.90
0.59	29.80	N	-	48.00	18.20
0.65	28.20	N	-	48.00	19.80
1.72	27.50	N	-	48.00	20.50
2.60	26.90	N	-	48.00	21.10
13.12	34.00	H	-	48.00	14.00
15.01	34.50	N	-	48.00	13.50

Conducted Emissions Test Result

Pass Fail

Notes:

1. All modes of operation were investigated and the worst-case emissions are reported.
2. The test graph 11 page
3. Lines : H :Line's Name, N :Neutral.



Test Result

Radiated Emissions

Distant: 3m

Frequency (MHz)	Level (dBuV)	Pole H/N	Factors(dBuv)		Emission Level(dBuV/m)	Limit (dBuV)	Margin (dBuV)
			Ant	Cable			
53.24	24.40	H	6.93	1.76	33.10	40.00	6.90
79.83	23.20	H	6.77	2.10	32.06	40.00	7.94
133.04	21.20	H	10.82	2.80	34.82	43.50	8.69
212.91	24.00	H	9.37	3.75	37.13	43.50	6.37
266.15	22.50	V	11.99	4.36	38.85	46.00	7.15
345.99	19.50	H	14.22	4.98	38.70	46.00	7.30

Radiated Emissions Test Result

Pass

Fail

Notes:

1. All modes of operation were investigated and the worst-case emissions are reported.
2. Detail date : 12 Page
3. Pole : H :Horizontal, V :Vertical.

Conducted Emission Data

Report Number: DAC02-K0184

Page 11 of 21

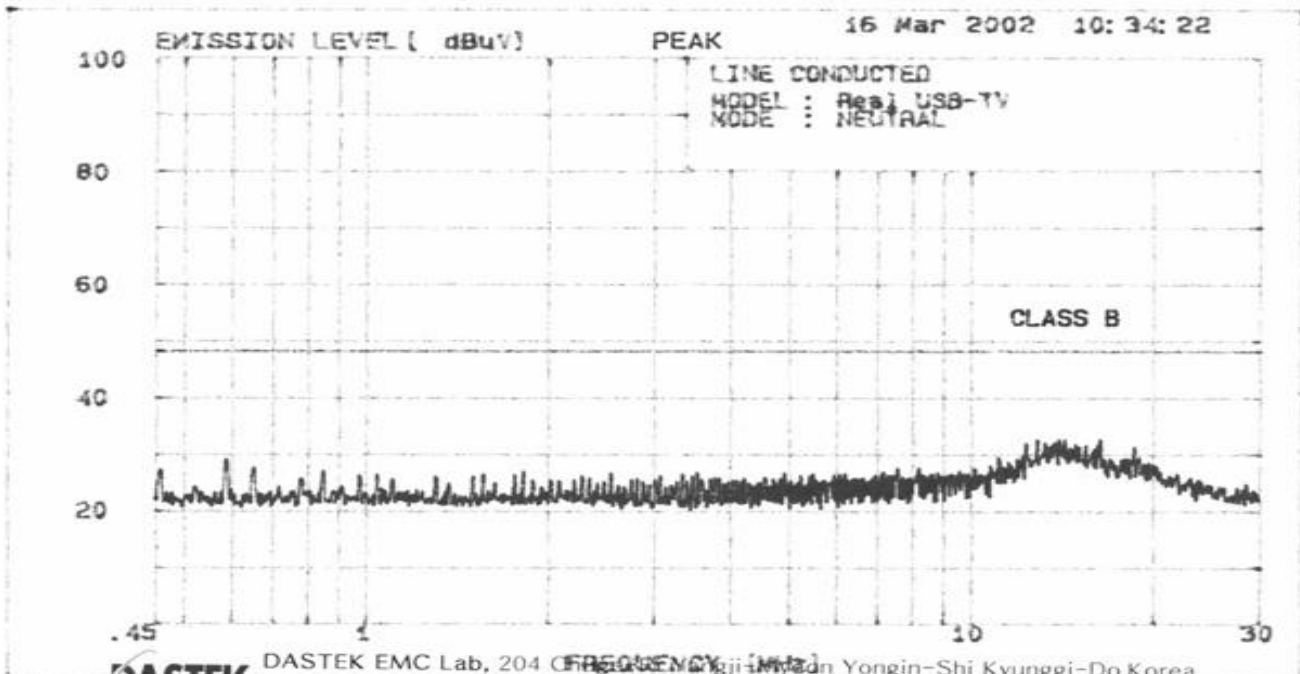
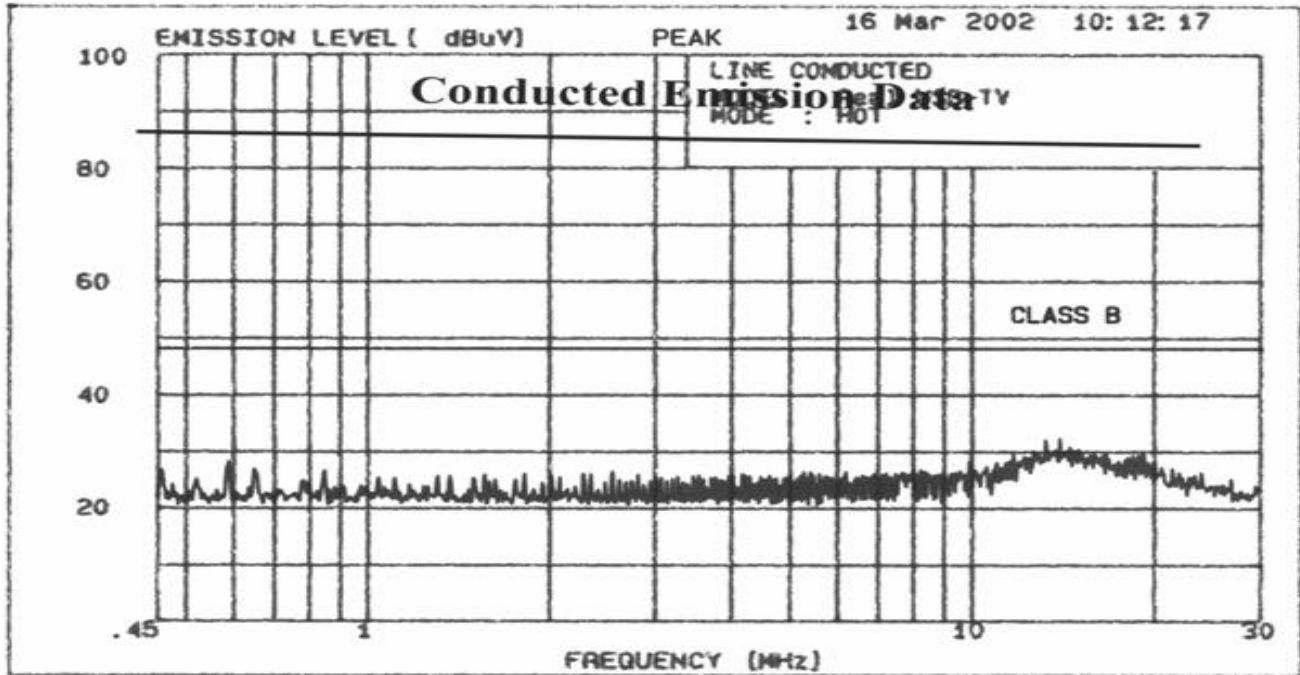

DASTEK EMC Lab, 204 Chuge-Ri Yangji-Myeon Yongin-Shi Kyunggi-Do, Korea

Tel:82-31-335-9341 Fax: 82-31-335-9343



DASTEK EMC Lab, 204 Chuge-Ri Yangji-Myeon Yongin-Shi Kyunggi-Do, Korea

Tel:82-31-335-9341 Fax: 82-31-335-9343

Radiated Emission Data

***** DASTEK Co., Ltd. DASTEK EMC TEST SITE *****

INTERFERENCE RADIATION TEST REPORT

according to : ANSI-C63.4 1992

GRANTEE : DIVACESS INC.
 MODEL NUMBER : Real USB-TV
 SERIAL NUMBER : 100007
 FCC ID CODE :
 POWER SOURCE :
 DATE TESTED : 2002. 03.16
 FILE NUMBER :
 REGULATION : FCC PART 15 CLASS B
 ANT.PAD [dB] : 0.0
 DISTANCE [m] : 3.0

No	FREQ [MHz]	ANT	READING LEVEL [dBuV]	Pole H/V	ANT FACTOR [dB]	CABLE LOSS [dB]	AMP GAIN [dB]	EMISSION		MARGIN [dB]
								LEBEL [dBuV/m]	LIMIT	
1	53.24	BILOG	24.40	H	6.93	1.76	0.00	33.10	40.00	6.90
2	79.83	BILOG	23.20	H	6.77	2.10	0.00	32.06	40.00	7.94
3	133.04	BILOG	21.20	H	10.82	2.80	0.00	34.82	43.50	8.69
4	212.91	BILOG	24.00	H	9.37	3.75	0.00	37.13	43.50	6.37
5	266.15	BILOG	22.50	H	11.99	4.36	0.00	38.85	46.00	7.15
6	319.40	BILOG	18.20	V	13.40	4.82	0.00	36.41	46.00	9.59
7	345.99	BILOG	19.50	H	14.22	4.98	0.00	38.70	46.00	7.30

MISSION LEVEL = READING LEVEL + ANTENNA FACTOR
 CABLE LOSS- AMP GAIN + ANTENNA PAD

 JUN-HO, CHOI Engineer



Sample Calculations (Radiated)

$$\text{dBuV} = 20 \log_{10}(\text{uV/m})$$
$$\text{uV} = 10^{(\text{dBuV}/20)}$$

EX 1.

@ 162.03 MHz

Class A limit = 43.50 dBuV (Distant 10m)

Emission Level (dBuV) = Level + Factors [Ant + Cable] (dBuV)

$$26.81 \text{ (dBuV)} = 9.20 + 15.27 + 2.34 \text{ (dBuV)}$$

Margin (dBuV) = Limit - Emission Level (dBuV)

$$16.69 \text{ (dBuV)} = 43.50 - 26.81$$

Test Equipment

<u>Test Equipment</u>	<u>Model</u>
Test Receiver (9KHz-30MHz)	Rhode & Schwarz ESH2
Test Receiver (20-1000MHz)	Rhode & Schwarz ESV
Spectrum Analyzer	Hewlett-Packard 8568B
Spectrum Analyzer	Hewlett-Packard 8591A
Quasi Peak Adapter	Hewlett-Packard 85605A
RF Preselector	Hewlett-Packard 85685A
RF Amplifier	Hewlett-Packard 8447D
Controller	Hewlett-Packard 98580bB
Signal Generator	Hewlett-Packard 8657A
Color Plotter	Hewlett-Packard 7440A
Color Plotter	Hewlett-Packard 7550B
Printer	Hewlett-Packard 2235D
Printer	Hewlett-Packard 2225D
Absorbing Clamp	Rhode & Schwarz MDS-21
Biconical Antenna (30-200MHz)	EMCO 3104
Biconical Antenna (30-300MHz)	Schwarzbeck BBA-9106
Log Periodic Antenna (200-1GHz)	EMCO 3146
Log Periodic Antenna (300-1GHz)	Schwarzbeck UHALP-9107
Biolog Antenna	Schaffner CLB6112
VHF Dipole Antenna	Schwarzbeck VHA 9103
UHF Dipole Antenna	Schwarzbeck UHA 9105
VHF Precision Dipole Antenna	Schwarzbeck VHAP
UHF Precision Dipole Antenna	Schwarzbeck UHAP
Passive Loop Antenna (1K-30MHz)	EMCO 6509
Active Loop Antenna (1K-30MHz)	EMCO 6507
Passive Rod Antenna (1K-30MHz)	EMCO 3303
Active Rod Antenna (30Hz-50MHz)	EMCO 3301B
LISN	Rhode & Schwarz ESH2-Z5
LISN	Rhode & Schwarz ESH3-Z5