

Outdoor Wireless Access Point

User's Manual

Before operating the unit, please read this manual thoroughly, and retain it for future reference.

Contents

CHAPTER 1. HARDWARE INSTALLATION	1
1.1 BEFORE YOU START	1
1.2 LOCATE THE ACCESS POINT AND INLINE POWER INJECTOR PORTS	2
1.3 INSTALLING THE ANTENNAS.....	4
1.4 INSTALLING THE CONSOLE PORT CABLE	5
1.5 CONNECTING THE POWER SUPPLY AND ETHERNET CABLE	5
1.6 OUTDOOR INSTALLATION.....	6
CHAPTER 2. NETWORK TOPOLOGIES	7
2.1 CONFIGURATION EXAMPLES	8
2.1.1 <i>Wireless Access Bridge</i>	8
2.1.2 <i>Wireless Access Router with PPPoE Ethernet connection</i>	9
2.1.3 <i>Wireless Access Router with dynamic IP Ethernet connection</i>	10
2.1.4 <i>Wireless Access Router with static IP Ethernet connection</i>	11
CHAPTER 3. INITIAL CONFIGURATION	12
3.1 CONFIGURE REQUIREMENTS	12
3.2 CONFIGURE THE AP	14
3.2.1 <i>Configure the AP as a Bridge</i>	15
3.2.2 <i>Configure the AP as a Router with PPPoE Ethernet connection</i>	16
3.2.3 <i>Configure the AP as a Router with dynamic IP address Ethernet</i>	21
3.2.4 <i>Configure the AP as a Router with static IP address Ethernet</i> ..	22
3.3 CONFIGURE WIRELESS RELATED PARAMETERS	24
3.4 SECURITY.....	25
3.4.1 <i>WEP encryption</i>	25
3.4.2 <i>Hide the SSID</i>	25
3.4.3 <i>Deny 'ANY' client station</i>	25
3.4.4 <i>IEEE 802.1x Access Control</i>	26
3.4.5 <i>MAC based Access Control</i>	27
3.5 CONFIGURE DHCP SERVER	28
3.6 CONFIGURE VIRTUAL SERVER	29
3.7 CONFIGURE ROUTING TABLE	31
3.8 CONFIGURE BRIDGE	32
3.9 CONFIGURE SNMP	33
3.10 CONFIGURATION REVIEW AND APPLY THE NEW SETTINGS.....	35

3.11 UTILITY 37

 3.11.1 System Info..... 37

 3.11.2 Software Upgrade 38

CHAPTER 4. TELNET CONFIGURATION 39

CHAPTER 5. SPECIFICATIONS 48

CHAPTER 6. DEFAULT SETTINGS 49

CHAPTER 7. REGULATORY COMPLIANCE INFORMATION 59

Chapter 1. Hardware Installation

This chapter describes the procedures for installing the SendFar Outdoor Access Point.

1.1 Before You Start

After unpacking the system, make sure the following items are present and in good condition.

1. Access Point
2. Inline Power Injector
3. AC Power Cord
4. MIL-C-5015 style RS232 Console Port Cable
5. Grounding Wire
6. Cross over Ethernet Cable
7. Two rubber dipole antenna
7. 30M MIL-C-5015 style Ethernet Cable
8. Mast Mounting Kit
10. Wall Mounting Kit
11. User' s Manual Disk
12. Simple Spanner



1.2 Locate the Access Point and Inline Power Injector Ports

- Special Ethernet port ① for connecting the MIL-C-5015 style Ethernet Cable
- Special serial port ② for connecting the MIL-C-5015 style RS-232 console port cable
- Grounding port ③.
- Special N-Type connector ④ for connecting the antenna or RF cable.
- Power & Data output port ⑤ for connecting the other of the MIL-C-5015 style Ethernet Cable
- Data input port ⑥ for connecting the Ethernet Cable to a Hub Switch Router or a PC.

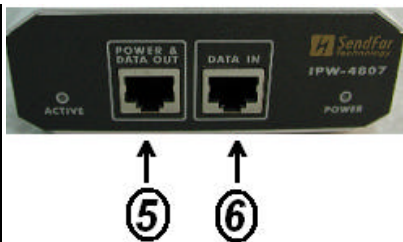
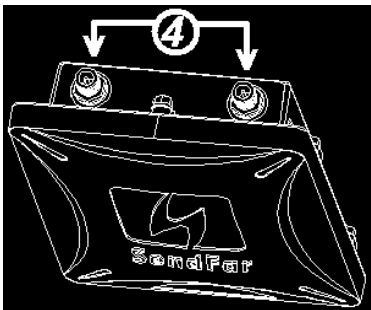
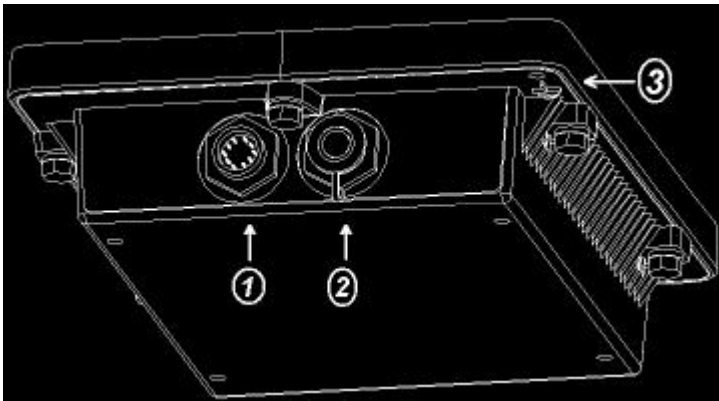

1.3 Installing the Antennas

Step 1: With the unit powered off, attach the dipole antenna to the antenna connector as shown in **Figure 1.3**.

NOTE: Do not over-tighten; finger tight is sufficient. Position the antenna vertically for best omni-directional signal reception.

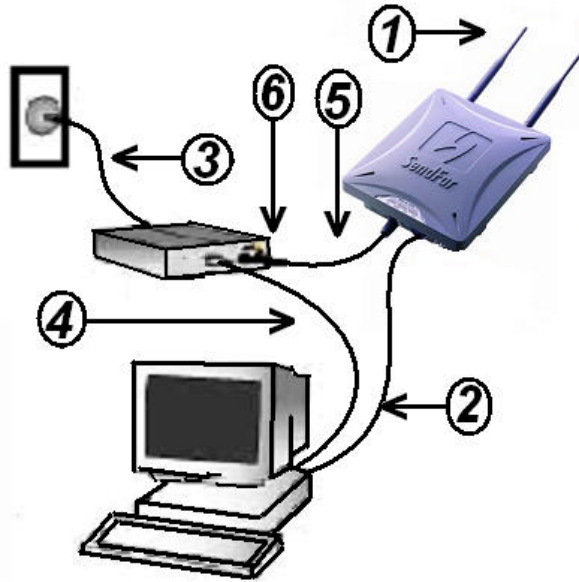

Figure 1.3.

Before installing your WLAN system, we recommend that you test the Access Point using the dipole antenna included in your package. Once testing is completed, install your Access Point for use with the appropriate antenna for your application.

1.4 Installing the Console Port Cable

Step 2: Attach the Console Port cable to the Serial Port. Attach the other cable end to the Serial Port on a PC running a terminal emulation program, and set the terminal to **115200 Baud, No-Parity, 8 data bits, 1 Stop bit, and ANSI compatible**.

NOTE: This connection is required for setting up initial configuration information.

After configuration is completed, this cable may be removed until additional configuration is required via the Serial Port.

1.5 Connecting the power supply and Ethernet cable

Step 3 Plug the female end of the power cord into the Inline Power Injector, and then plug the male end of the power cord into a power outlet or power strip. The Power LED on the front of the Inline Power Injector will light up.

Step 4 Run the cross over Ethernet cable (included in your package) from Data Input Port (on the front of the Inline Power Injector) to the Ethernet Port on the PC we mentioned above.

NOTE: This connection is required for setting up initial configuration information. After configuration is completed, this cable will be removed, and then you should run an Ethernet cable from Data Input Port (on the front of the Inline Power Injector) to the LAN connection (such as a hub or concentrator).

Step 5 Plug the MIL-C-5015 style Ethernet connector into the Special Ethernet port on the back of the access point.

Step 6 Plug the RJ-45 Ethernet connector (the other end of the Special Ethernet cable) into the Power & Data Output Port on the front of the Inline Power Injector. When the Access Point receives power over the Ethernet cable, the Access Point will start its boot sequence and the Active LED on the front of the Inline Power Injector will light up.

1.6 Outdoor Installation

Outdoor Access Point device can be mounted on the side of a building or mounted to an mast as shown in following:

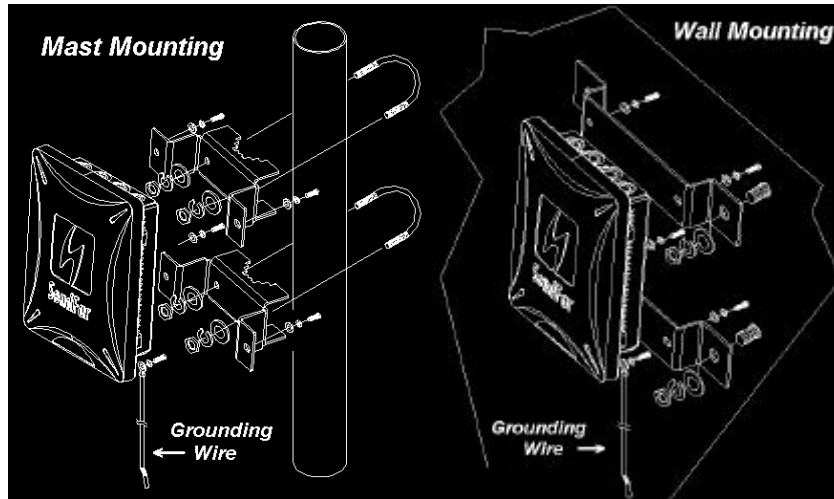

A wall (side) mount allows for mounting the Outdoor AP on the side of a building. This will provide a convenient mounting location when the roof overhang is not excessive and/or the location is high enough to provide a clear line of sight.

Grounding

A safety grounding system is necessary to protect your outdoor installation from lightning strikes and the build-up of static electricity. So direct grounding of the antenna mast, Outdoor AP and Surge Arrester is very important. And so mounting the Outdoor AP on the antenna mast, you have to connect the Outdoor AP to the same grounding system with the AC wall outlet. The grounding system must comply with the National Electrical Code and safety standards that apply in your country. Always check with a qualified electrician if you are in doubt as to whether your outdoor installation is properly grounded.

Chapter 2. Network Topologies

This chapter describes several main types of installations commonly implemented using the Outdoor Wireless Access Point (AP). This is by no means intended to be an exhaustive list of all possible configurations, but rather shows examples of some of the more common implementations (as shown in **Figure 2-1**).

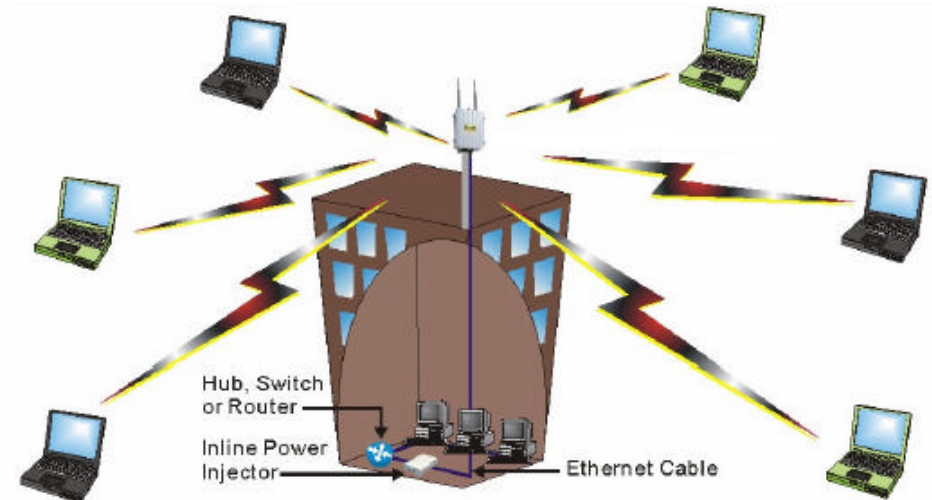

Figure 2-1

The outdoor wireless AP can perform in router or bridge modes. In a wireless topology, all communication between network stations is done through a centralized Access Point. To show some possibilities of wireless topologies, the following examples are provided:

1. Wireless Access Bridge
2. Wireless Access Router with PPPoE Ethernet connection
3. Wireless Access Router with dynamic IP address Ethernet
4. Wireless Access Router with static IP address Ethernet

2.1 Configuration Examples

2.1.1 Wireless Access Bridge

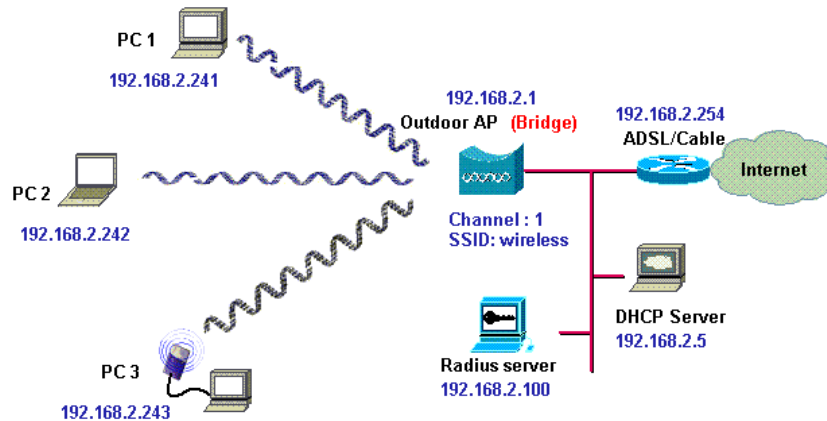

1. Set the Outdoor AP as a bridge (*bridge IP address is 192.168.2.1*).
2. Set Wireless parameters on Outdoor AP: Channel (1) and SSID (*wireless*)
3. Set Wireless parameters on client stations PC1, PC2 and PC3: SSID (*wireless*).
4. Left side stations are transparent to the right side network.
5. DHCP server assigns IP address to PC1, PC2 and PC3.

2.1.2 Wireless Access Router with PPPoE Ethernet connection

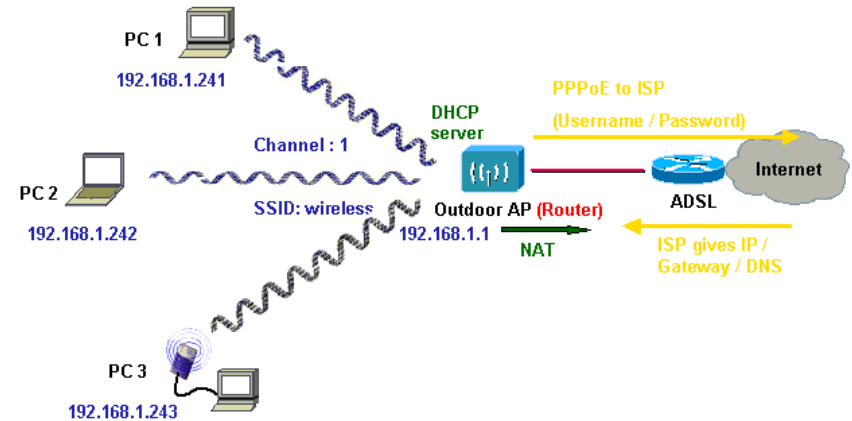

1. Set the Outdoor AP as a Router (*Wireless Interface IP is 192.168.1.1, Ethernet Interface IP is 192.168.2.1, must turn on NAT on Ethernet Interface and turn off NAT on Wireless interface, default route is 0.0.0.0*).
2. Turn on PPPoE Interface (*Interface NO.3*) and specify that your personal ISP provided PPPoE Username and PPPoE Password to enable ADSL broadband access.
3. Set Wireless parameters on Outdoor AP: Channel (1) and SSID (*wireless*)
4. Turn on DHCP server on the Outdoor AP and assign IP address to PC1, PC2 and PC3.
5. Set Wireless parameters on client stations PC1, PC2 and PC3: SSID (*wireless*).

2.1.3 Wireless Access Router with dynamic IP Ethernet connection

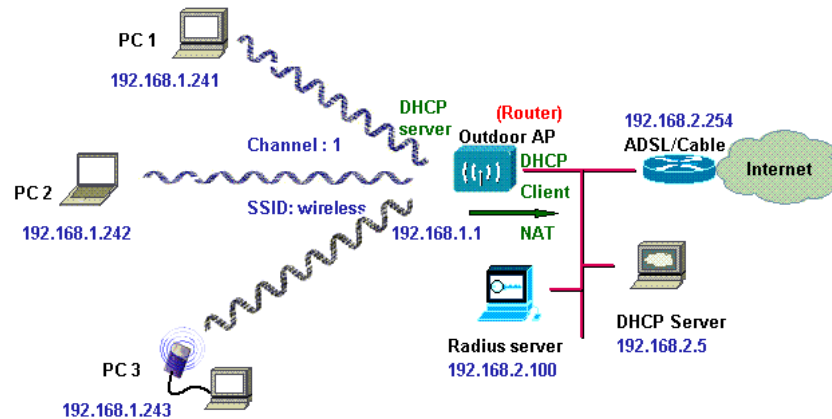

1. Set the Outdoor AP as a Router (Wireless Interface IP is 192.168.1.1, must turn on NAT on Ethernet Interface and turn off NAT on Wireless interface).
2. Enable DHCP client on the Ethernet Interface of the Outdoor AP (This AP will get IP / Gateway / DNS from the DHCP server).
3. Set Wireless parameters on the Outdoor AP: Channel (1) and SSID (wireless)
4. Turn on DHCP server on the Outdoor AP and assign IP address to PC1, PC2 and PC3.
6. Set Wireless parameters on client stations PC1, PC2 and PC3: SSID (wireless).

2.1.4 Wireless Access Router with static IP Ethernet connection

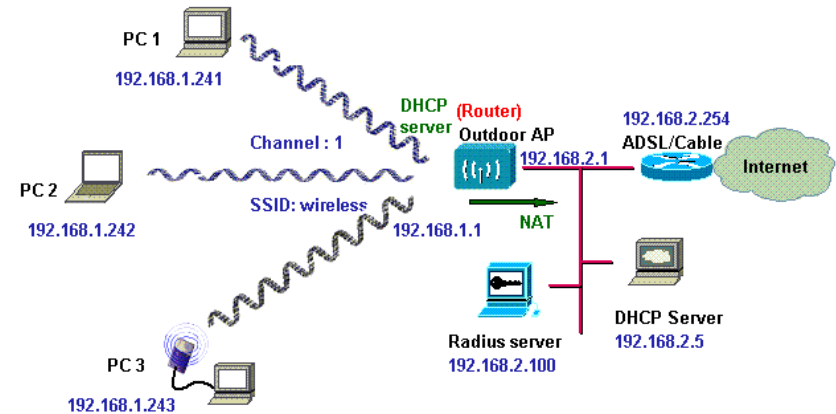

1. Set the Outdoor AP as a Router (Wireless Interface IP is 192.168.1.1, Ethernet Interface IP is 192.168.2.1, must turn on NAT on Ethernet Interface and turn off NAT on Wireless interface, default route is 192.168.2.254).
2. Set Wireless parameters on Outdoor AP: Channel (1) and SSID (wireless)
3. Turn on DHCP server on the Outdoor AP and assign IP address to PC1, PC2 and PC3.
4. Set Wireless parameters on client stations PC1, PC2 and PC3: SSID (wireless).

Chapter 3. Initial Configuration

This chapter describes how to easy setup and configure the Wireless Broadband Access Point (AP) initially. The AP can be configured into a bridge and a broadband wireless router to meet different applications. Users can use a wired LAN-attached computer to configure the AP through a web browser or a telnet session on a LAN computer.

In this chapter, we only describe how to quickly configure the AP with a web browser. For detailed descriptions of the many configuration parameters and network configuration, refer to Chapter 4.

3.1 Configure Requirements

The AP is shipped with configuration that can be utilized right out of the box. Default configuration is as a bridge between an Ethernet and wireless network. Users simply need to attach the AP to your wired LAN. If users would like to configure the AP, please refer to the following procedures.

Before setup, we must install AP first

1. Connect power adaptor and power on the AP
2. Connect the Ethernet cable for connecting the AP to the network
3. Connect a computer to the same network with this AP
4. Start your Microsoft Internet Explorer web browser program from a LAN-attached computer. To access the web interface of the AP, you have to disable Access the Internet using a proxy server function in Windows 2000 [Control Panel / Internet Options / Connections/LAN Settings] as shown in **Figure 3-1**.
5. Type the IP address and HTTP port of the AP (**default port is 2000, IP is 192.168.2.1**) in the address field (**http://192.168.2.1:2000/**) and press *Enter*. Make sure that the IP addresses of AP and your computer are in the same subnet.
6. After the connection is established, you will see the user identification window as shown in **Figure3-2**, and key-in the proper **User Name** and **Password** to see the web user interface of the AP. The default user name and password is *root* and *root*, respectively

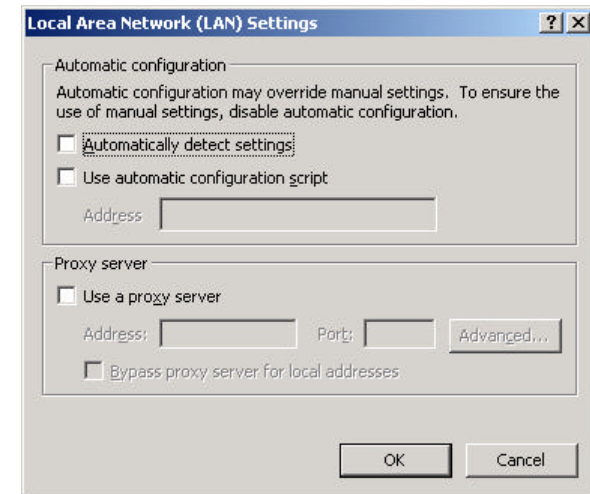

Figure 3-1

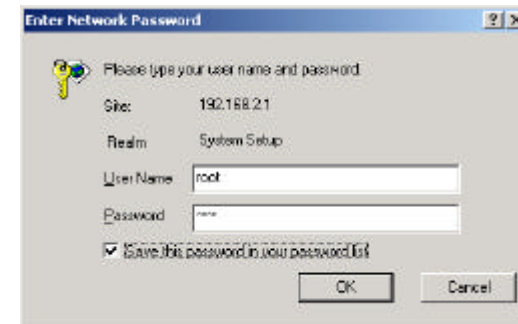

Figure 3-2

3.2 Configure the AP

The AP can be configured into four operation modes:

1. Outdoor Wireless Bridge
2. Outdoor Wireless Router with PPPoE Ethernet connection
3. Outdoor Wireless Router with dynamic IP address Ethernet
4. Outdoor Wireless Router with static IP address Ethernet

The AP is shipped with default configuration is as a bridge between an Ethernet and wireless network. Users simply need to attach the AP to your wired LAN. If users would like to configure the AP, please refer to the following procedures.

The web user interface can be grouped into Quick setup, Basic Configuration, Advanced Configuration and Utility as shown in **Figure 3-3**. The left frame contains, in a tree structure, the contents of the AP web configuration interface. Move through the tree by clicking on an icon to expand or collapse the tree. The nodes on the tree represent web pages that allow you to view and modify the parameters of the AP.

If users want to connect multiple wireless computers to a broadband (ADSL or Cable) modem or an Ethernet switch to surf the Internet, you need to configure the AP as a broadband wireless router to share a single IP address with the multiple wireless computers as described as follows.

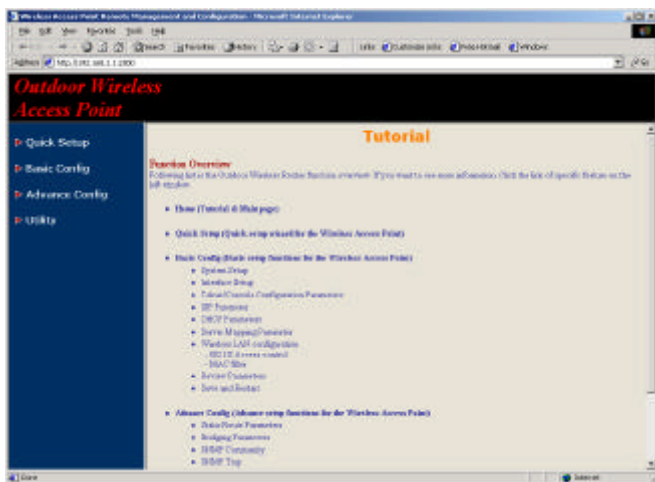

Figure 3-3

3.2.1 Configure the AP as a Bridge

Configure TCP/IP parameters

1. Click **Advanced Config**, select **Bridging**, and then click **Enable** for **Bridge Function** as shown in **Figure 3-4**. In the **Bridging Parameter** window, enter the **IP Address (default is 192.168.2.1)** and **Subnet Mask (default is 255.255.255.0)** that are suitable for your network domain. After that, click **FINISH** at the bottom of this page to complete the modification of this page.

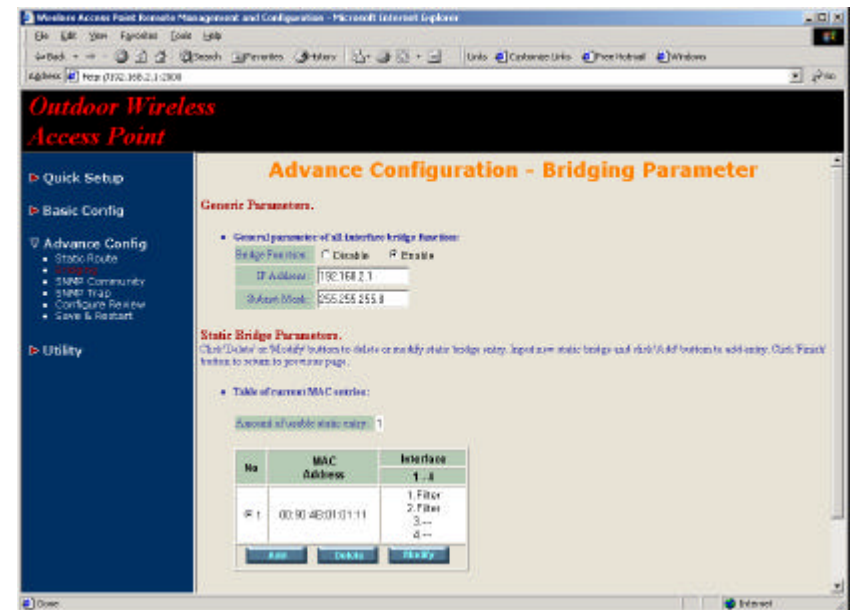

Figure 3-4

3.2.2 Configure the AP as a Router with PPPoE Ethernet connection

Configure TCP/IP parameters

1. Click **Advanced Config**, select **Bridging**, and then click **Disable** for **Bridge Function** as shown in **Figure 3-4**. After that, click **FINISH** at the bottom of this page to complete the modification of this page.
2. If you are an ADSL subscriber, you need specify that your personal ISP PPPoE username and password to enable ADSL broadband access, in here, click **Basic Config**, select **ISP** (as shown in **Figure 3-5**). In this page, enter **MODIFY** button to setup the correct ISP parameters: **ISP Name**, **ISP Phone**, **PPPoE Username** and **PPPoE Password** to (as shown in **Figure 3-6**).

Hint: Ask your ISP for the correct settings.

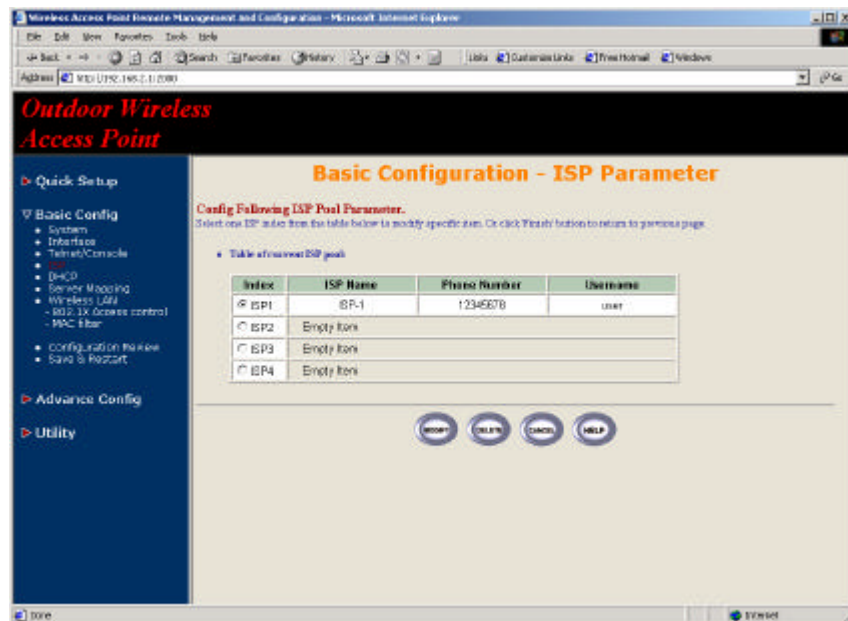

Figure 3-5

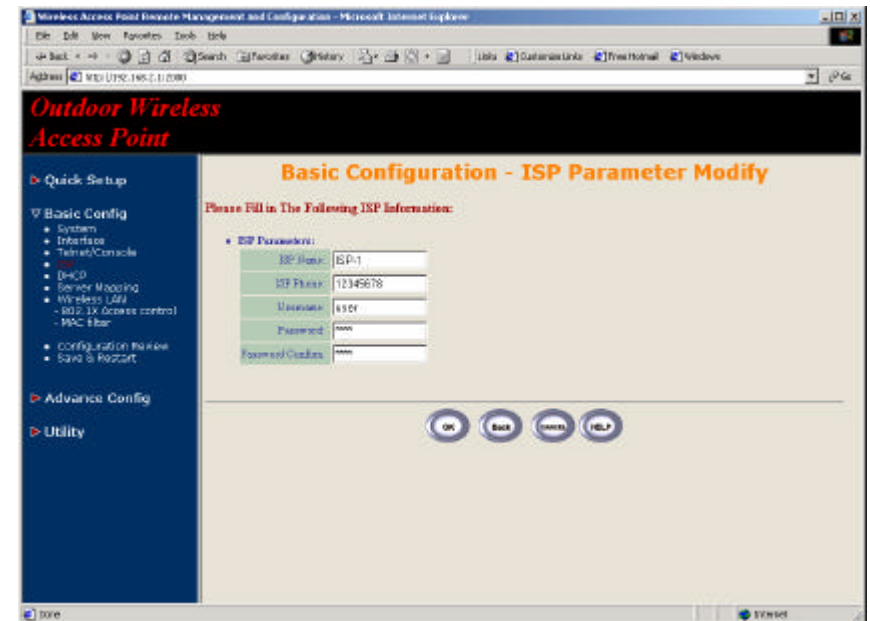

Figure 3-6

3. Click **Basic Config**, select **Interface** (as shown in **Figure 3-7**) and in this page, you can click radio button and enter **MODIFY** to choice which one that you want to change it (as shown in **Figure 3-8**).

In interface 1, Make sure this wireless interface status is **Active**, enter the **Wireless interface IP (default is 192.168.1.1)** and **Wireless interface Net Mask (default is 255.255.255.0)** that are suitable for your wireless network.

In interface 2, Make sure this **Ethernet interface status** is **Active**, and specify the **Ethernet IP address (default is 192.168.2.1)** and **Ethernet Net Mask (default is 255.255.255.0)** of the Ethernet interface.

In interface 3, Make sure this PPPoE interface status is **Active**, and specify the **Ethernet IP address (default is 192.168.3.1)** and **Ethernet Net Mask (default is 255.255.255.0)**, choice the **ISP index** that your are configured in step 1. After that, follow the default setting and Click the **OK** button to return to the **Interface Parameter** window. Finally, you need to click **FINISH** at the bottom of this page to complete the modification of this page.

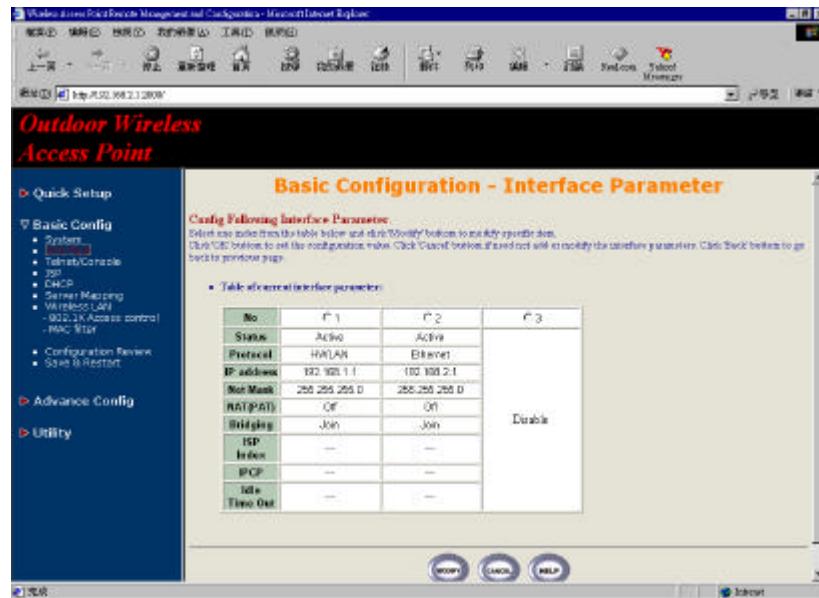

Figure 3-7

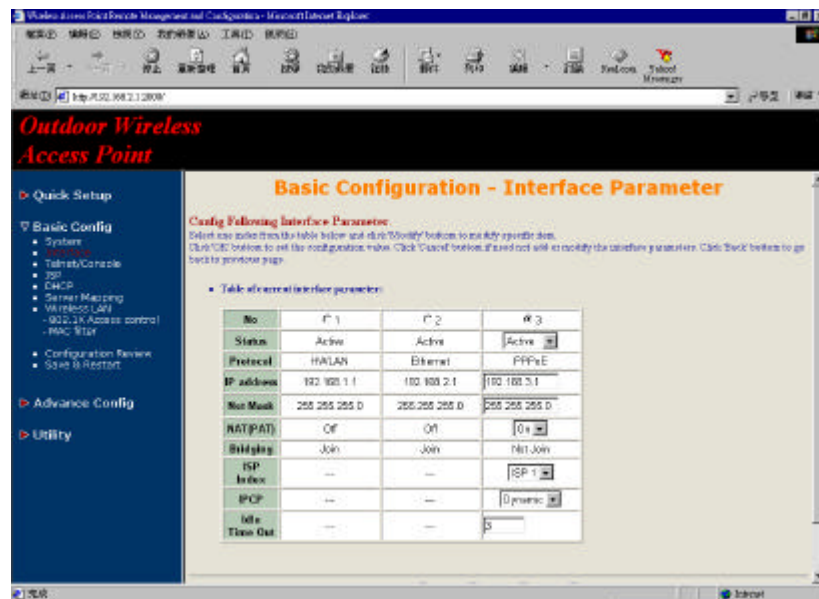

Figure 3-8

Hint1: Make sure interface 4 within status *Disable*.

Hint2: Choice the *NAT (PAT)* in every interfaces to enable NAT service. For example, make sure PPPoE interface within *NAT (PAT) On* and others are *Off*, it means that every communications through the PPPoE interface needs NAT transfer.

- The AP supports PPPoE auto dial-up, please make sure your **default route** is zero. In here, click **Basic Config**, and then select **System** as shown in Figure 3-9. In the **System Setup** page, specify the **Default Route (Default is 192.168.2.254)** is **0.0.0.0** and then click **FINISH** button at the bottom of this page to complete the modification of this page.

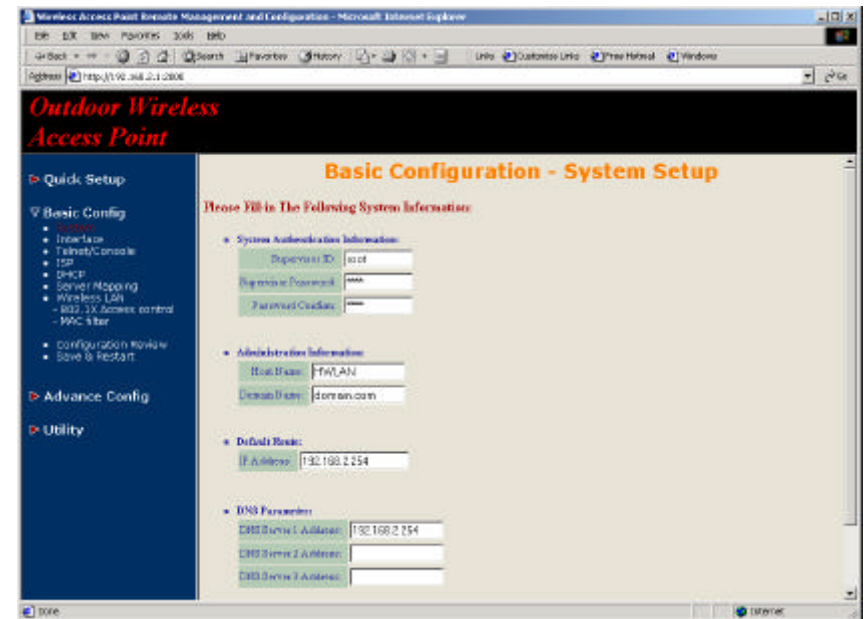

Figure 3-9

- Click **Basic Config**, select **DHCP** (as shown in Figure 3-10) and make sure the DHCP client service is in **Disable**. After that, click **FINISH** at the bottom of this page to complete the modification of this page.

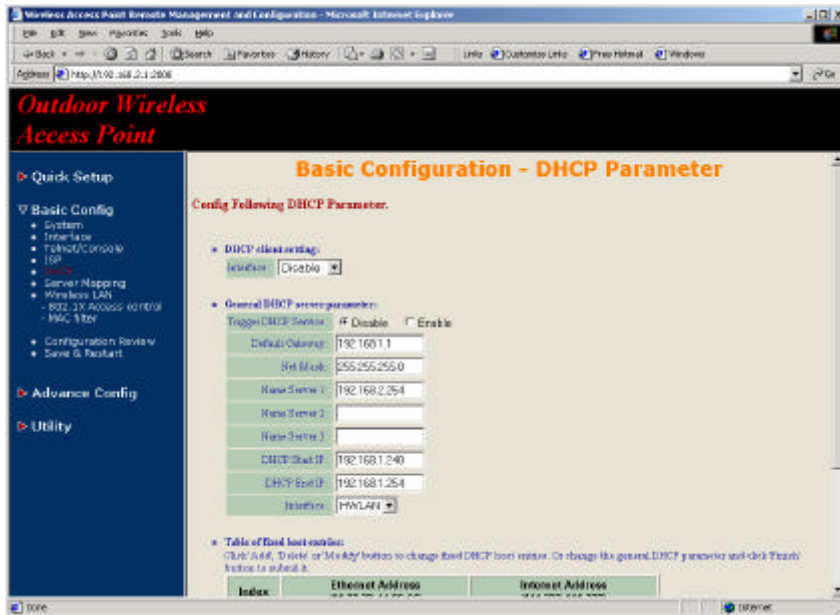

Figure 3-10

3.2.3 Configure the AP as a Router with dynamic IP address Ethernet

Configure TCP/IP parameters

1. Click **Advanced Config**, select **Bridging**, and then click **Disable** for **Bridge Function** as shown in **Figure 3-4**. After that, click **FINISH** at the bottom of this page to complete the modification of this page.
2. Click **Basic Config**, select **Interface** (as shown in **Figure 3-7**), in this page, you can click radio button and enter **MODIFY** to choice which interface that you want to change it (as shown in **Figure 3-8**).

In interface 1, Make sure this wireless interface status is **Active**, enter the **Wireless interface IP (default is 192.168.1.1)** and **Wireless interface Net Mask (default is 255.255.255.0)** that are suitable for your wireless network.

In interface 2, Make sure this Ethernet interface status is **Active**, and other parameters will obtain automatically by DHCP from your network environment.

Click the **OK** button to return to the **Interface Parameter** window. Finally, you need to click **FINISH** at the bottom of this page to complete the modification of this page.

Hint1: Make sure interface 3 and 4 within status: Disable.

Hint2: In order to enable NAT service, choice the NAT (PAT) in the interface Wireless and Ethernet. For example, make sure Ethernet interface within NAT (PAT) On and Wireless interface is NAT (PAT) Off, it means that every communication through the Ethernet interface needs to do NAT transfer.

3. Click **Basic Config**, select **DHCP** (as shown in **Figure 3-10**) and apply the DHCP client service running on interface 2 (Ethernet interface), After that, click **FINISH** at the bottom of this page to complete the modification of this page.

3.2.4 Configure the AP as a Router with static IP address Ethernet

Configure TCP/IP parameters

1. Click **Advanced Config**, select **Bridging**, and then click **Disable** for **Bridge Function** as shown in **Figure 3-4**. After that, click **FINISH** at the bottom of this page to complete the modification of this page.
2. Click **Basic Config**, select **DHCP** (as shown in **Figure 3-10**) and make sure the DHCP client service is **Disable**. After that, click **FINISH** at the bottom of this page to complete the modification of this page.
3. Click **Basic Config**, select **Interface** (as shown in **Figure 3-7**). In this page, you can click radio button and enter **MODIFY** to choice which interface that you want to change it(as shown in **Figure 3-8**).

In interface 1, Make sure this wireless interface status is **Active**, enter the **Wireless interface IP (default is 192.168.1.1)** and **Wireless interface Net Mask (default is 255.255.255.0)** that are suitable for your wireless network.

In interface 2, Make sure this Ethernet interface status is **Active**, and specify the **Ethernet IP address (default is 192.168.2.1)** and **Ethernet Net Mask (default is 255.255.255.0)** of the Ethernet interface.

Click the **OK** button to return to the **Interface Parameter** window. Finally, you need to click **FINISH** at the bottom of this page to complete the modification of this page.

Hint1: Make sure interface 3 and 4 within status: Disable.

Hint2: In order to enable NAT service, choice the NAT (PAT) in the interface Wireless and Ethernet. For example, make sure Ethernet interface within NAT (PAT) On and Wireless interface is NAT (PAT) Off, it means that every communication through the Ethernet interface needs to do NAT transfer.

4. Click **Basic Config**, and then select **System** as shown in **Figure 3-9**. In the **System Setup** page, specify the **Default Route (Default is 192.168.2.254)** as the IP Address of the ADSL/Cable modem connected to the AP or the IP Address of the Gateway in your LAN environment, and Specify at least one IP address of the **DNS parameter (Default DNS server 1 is 192.168.2.254)** provided by your ISP in the DNS

server parameter and then click **FINISH** button at the bottom of this page to complete the modification of this page.

3.3 Configure Wireless related parameters

Configure IEEE 802.11b WLAN parameters (as shown in **Figure 3-11**)

Click **Basic Config**, select **Wireless LAN** page. In here, enter the **Channel** (default is **1**), **rts Threshold** (default is **250**), **frag Threshold** (default is **1600**), **SSID** (default is **wireless**) and **Station Name** (default is **ap**) that are suitable for your radio network and then you can click radio button to disable WEP or enable 64/128 bit **WEP services** (default is **disable**), if WEP is enabled, you must input corresponded **Default Key index** and **WEP Key**. After that, click **FINISH** at the bottom of this page to complete the modification of this page.

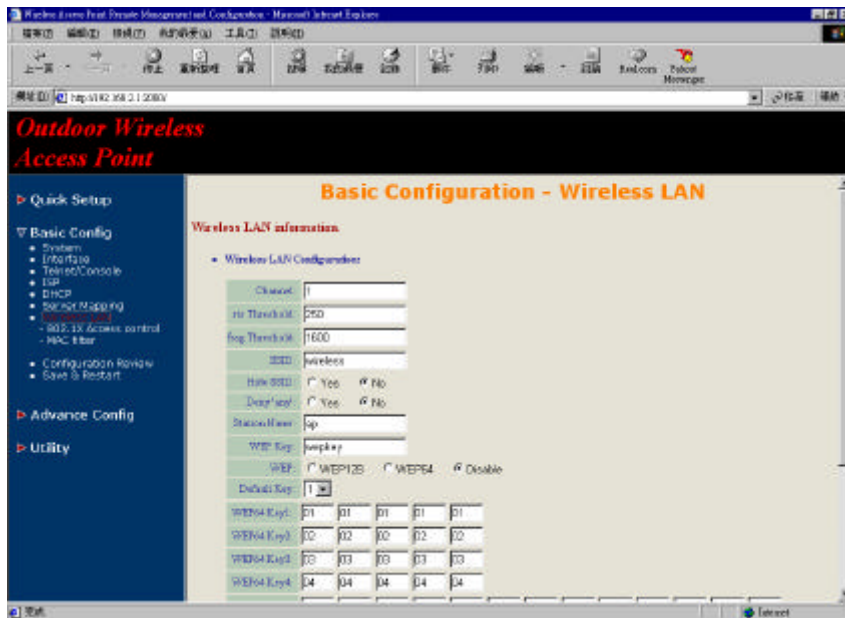

Figure 3-11

3.4 Security

3.4.1 WEP encryption

1. Click **Basic Config**, select **Wireless LAN** page, and configure it to **disable** or **enable** 64/128 bit WEP services (default is **Disable**) as shown in **Figure 3-11**.
2. Key-in the **WEP Key** and specify which WEP Key id you want to use it. After that, click **FINISH** at the bottom of this page to generate the real WEP key complete the modification of this page.

Hint: If you enable WEP services on AP, all of the communication between stations to AP will be encrypted. You must make sure all wireless clients with the same WEP key.

3.4.2 Hide the SSID

Click **Basic Config**, select **Wireless LAN** page, and click **Yes** or **No** to choose enable/disable the **Hide SSID** function on this wireless page (default is **No**), as shown in **Figure 3-11**.

Hint: If you enable Hide SSID on AP, all of the client stations must to specify the SSID of this AP, otherwise your client stations can't see (survey) this AP if using any Site Survey tools.

3.4.3 Deny 'ANY' client station

Click **Basic Config**, select **Wireless LAN** page, and click **Yes** or **No** to choose enable/disable the **Deny 'ANY'** function on this wireless page (default is **No**), as shown in **Figure 3-11**.

Hint: If you enable Deny ANY on AP, all of the client stations can't use the well define SSID keyword 'ANY' or 'any'.

3.4.4 IEEE 802.1x Access Control

You can configure Authenticator on AP:

1. Click **Basic Config**, select **802.1x Access Control** page, and choice the IEEE 802.1x services is **Enable** or **Disable** (as shown in **Figure 3-12**).

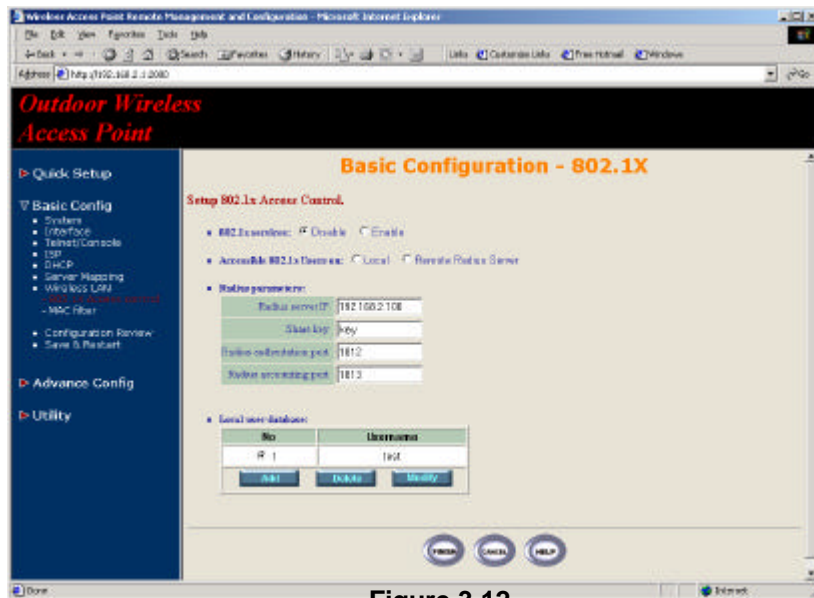

Figure 3-12

2. The AP supporting authentication which based on two kinds of user information base, **Local User Database** or **Remote Radius Servers**. You can specify which user database you want to use.
3. You can specify the **username/password** of an accessible 802.1x user. All user information entries in the **Local User Database** are permitted to connect to the AP. You can also click **ADD, DELETE, MODIFY** button to maintain this User Information table.
4. Some Radius server implements EAP authentication, like Microsoft Windows 2000 server or Cisco ACS. To set up the Radius server and AP for authentication, you must specify the **Radius server IP address**, **Share key** between AP and Radius server, **authentication port** and **accounting port** on this Radius server.

5. Click **FINISH** at the bottom of this page to complete the modification of this page.

3.4.5 MAC based Access Control

1. Click **Basic Config**, select **MAC Filter** page, and choice the MAC Filter services is **Enable** or **Disable** (as shown in **Figure 3-13**).
2. You can specify the MAC address of a wireless client station. All MAC entries in the MAC address table are permitted to connect to the AP. You can also click **ADD, DELETE, MODIFY** button to maintain this MAC address table. After that, click **FINISH** at the bottom of this page to complete the modification of this page.

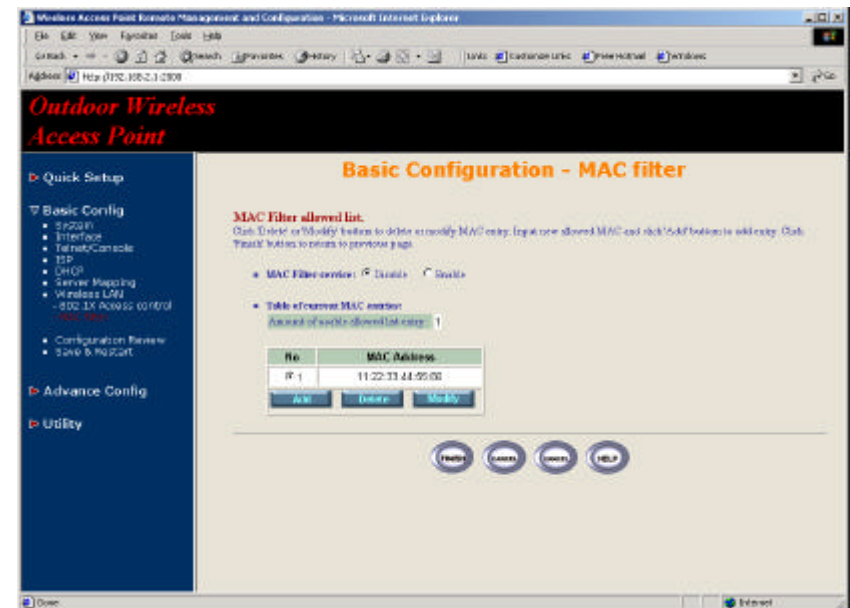

Figure 3-13

3.5 Configure DHCP server

Sometimes, the operator want to managing a large TCP/IP network requires maintaining accurate and up-to-date IP address and domain name information. In this situation, it needs manually configure and enable the DHCP server service.

1. Click **Basic Config**, select **DHCP** (as shown in **Figure 3-10**) and **Enable** the **DHCP server service** (Default is **Disable**).
2. Specify the **DHCP server parameters** (**Assign Gateway**, **Assign Subnet Mask**, **Assign DNS server**, **DHCP Start IP address**, **DHCP End IP address** and **Apply Interface**) to allow any DHCP client to acquire the IP information.

Assign Gateway: Configure the default router for the client.

Assign Subnet Mask Configure the subnet for the client.

Assign DNS Server: Configure the DNS servers IP for the client.

DHCP Start IP address, DHCP End IP address: Configure the DHCP IP address pool for the client.

Apply Interface: Enable DHCP server service on Wireless or Ethernet interface.

3. After that, click **FINISH** at the bottom of this page to complete the modification of this page.

Hint: The operator must to configure correct network settings in Gateway and DNS server of your wireless stations / Ethernet clients to surf the Internet.

3.6 Configure Virtual Server

Sometimes, the operator can expose the internal servers on the local intranet to the public Internet. For this, you must create the Virtual Server Mapping for these invisible internal servers.

1. Click **Basic Config**, select Server Mapping (as shown in **Figure 3-14**) and click **ADD**, **DELETE** or **MODIFY** button to change to configure Virtual Server Mapping page (as shown in **Figure 3-15**). In this page, you can maintain this Virtual Server Mapping pool (**Default Virtual Server Mapping pool is empty**) to enable the internal servers.

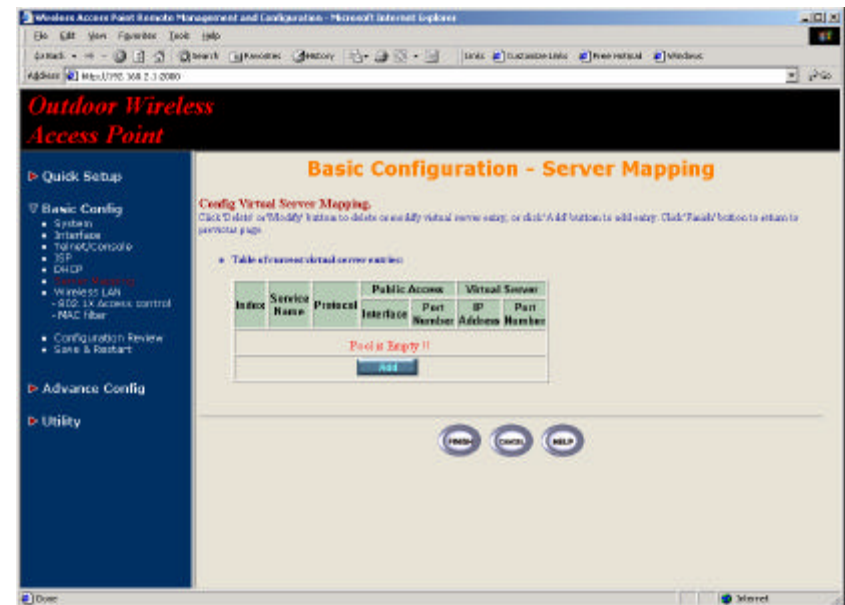

Figure 3-14

2. In configure Virtual Server Mapping page, you must specify some parameters (**Service Name**, **Protocol**, **Public Access Interface**, **Public Access Port number**, **Virtual Server IP address** and **Virtual Server Port Number**) to allow Internet user to access the Internal servers.

Service Name: Alias name of this internal server, such as FTP.

Access Interface: Indicate the translation occurs on which interface (Wireless interface, NO. 1/Ethernet interface, NO. 2), such as NO. 2.

Protocol: Indicate which protocol (TCP/UDP) you want to translate from outside to internal server, such as TCP.

Public Access Port number: Indicate which socket port (1 ~ 65535) you want to translate from outside to internal server, such as 21.

Virtual Server IP address: Specify the private IP address of the internal server, such as 192.168.1.100.

Virtual Server Port number: Specify the socket port (1 ~ 65535) of the internal server, such as 21.

3. After that, click **FINISH** at the bottom of PAT page to complete the modification for the Virtual Server Mapping.

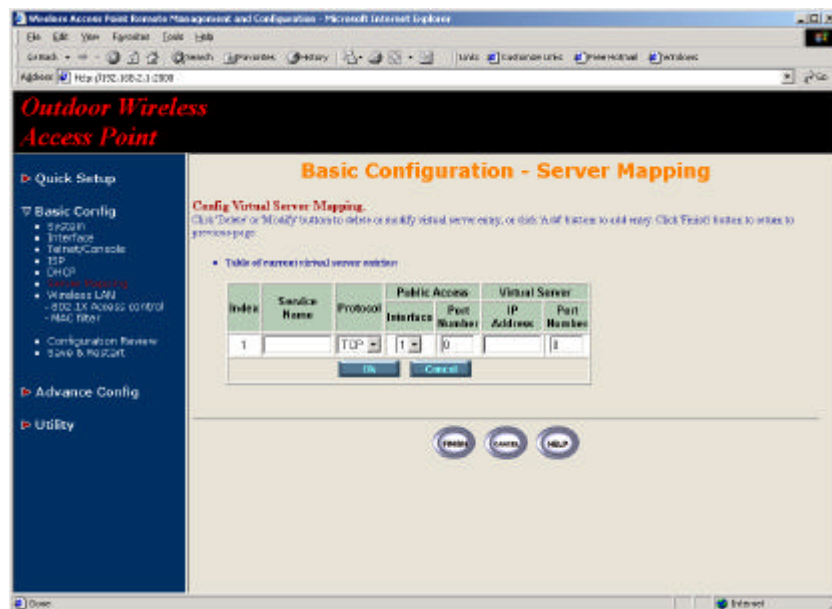

Figure 3-15

3.7 Configure Routing Table

1. Click **Advance Config** and select the **Static Route** page. This page (as shown in **Figure 3-16**) will present the current configuration for the routing table. You can also click **ADD**, **DELETE** or **MODIFY** button to maintain the **Static Routing table** (Default **Routing table** only contain single routing entry: **Default Route** entry).
2. Every **Route entry** contains three parameters: **Network Address**, **Subnet Mask** and **Gateway**. **Network Address** and **Subnet Mask** Specify the destination network. **Gateway**. Indicate the forward gateway.
3. After that, click **FINISH** at the bottom of this page to complete the modification of this page.

Hint: The operator must to configure correct routing settings following the network infrastructure.

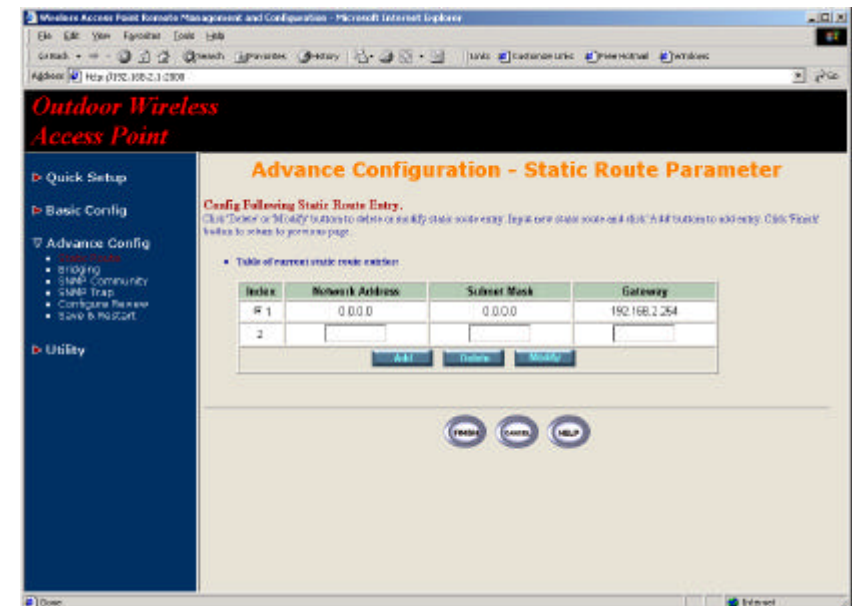

Figure 3-16

3.8 Configure Bridge

1. Click **Advance Config** and select the **Bridging**, and then click **Enable** for **Bridge Function** as shown in **Figure 3-4**. In the **Bridging Parameter** window, enter the **IP Address** (default is **192.168.2.1**) and **Subnet Mask** (default is **255.255.255.0**) that are suitable for your network domain.
2. You can specify the MAC address of a Wireless/Ethernet client. All MAC entries in the MAC address table are Permitted/Blocked/Learning to connect to the AP. In here, you can also click **ADD, DELETE, MODIFY** button to maintain this MAC address table.
3. After that, click **FINISH** at the bottom of this page to complete the modification of this page.

3.9 Configure SNMP

1. Click **Advance Config** and select the **SNMP Community** page. This page (as shown in **Figure 3-17**) will present the current accessible SNMP communities and correspond Read/Write privilege. After that, click **FINISH** at the bottom of this page to complete the modification of this page.

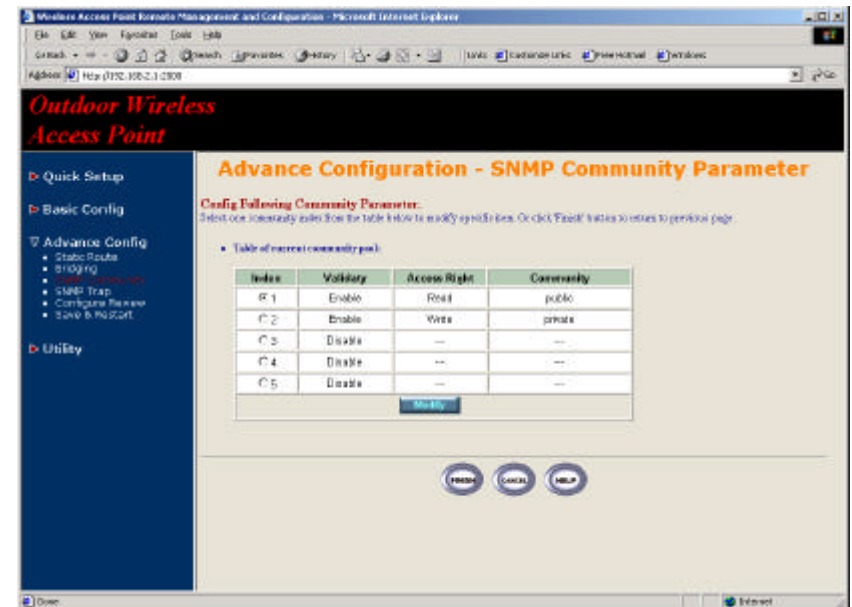

Figure 3-17

2. Click **Advance Config** and select the **SNMP Trap** page (as shown in **Figure 3-18**). In this page, you can specify the **SNMP Trap host** and correspond **SNMP Trap Community** in this page. After that, click **FINISH** at the bottom of this page to complete the modification of this page.

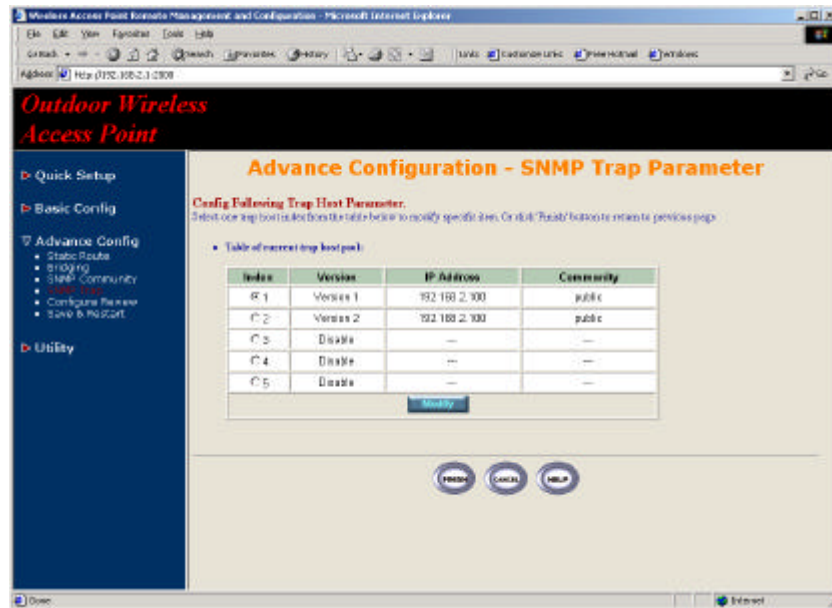

Figure 3-18

3.10 Configuration Review and Apply the New Settings

1. Click **Basic Config** or **Advance Config** and select the **Configuration Review** page. This page (as shown in **Figure 3-19**) will present the current configuration settings the operator has made.
2. Click **Basic Config** or **Advance Config** and select the **Save & Restart** page. In this page (as shown in **Figure 3-20**), you can click the **SAVE** button to apply the new configuration settings and click the **Restart** button to take effect the previous configuration changes.

Hint: It needs to take about 10 seconds for the AP to complete the restart process.

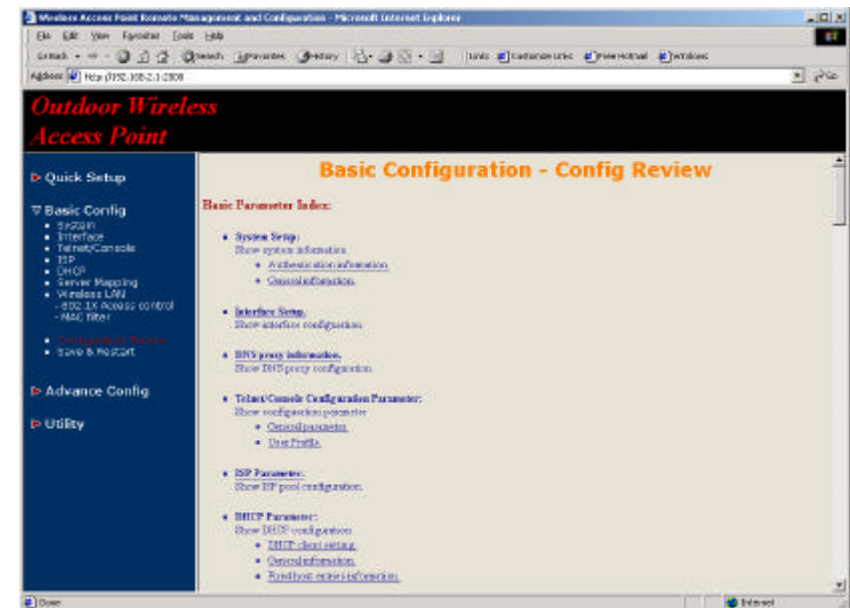

Figure 3-19

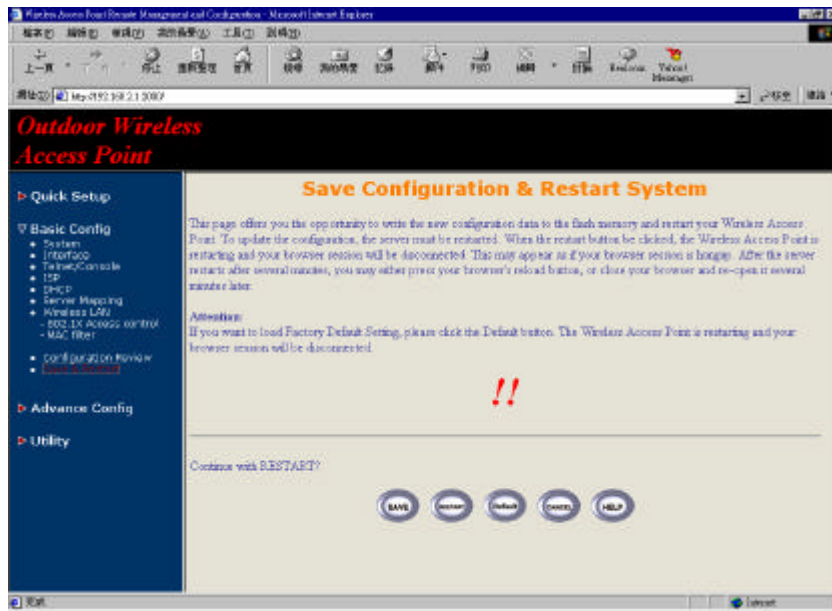

Figure 3-20

3.11 Utility

3.11.1 System Info

Click **Utility**, select **System Info** page (as shown in **Figure 3-21**), you can view some system information on this, such as **Model Name**, **Software Version**, **CPU** and **RAM**, ...etc.

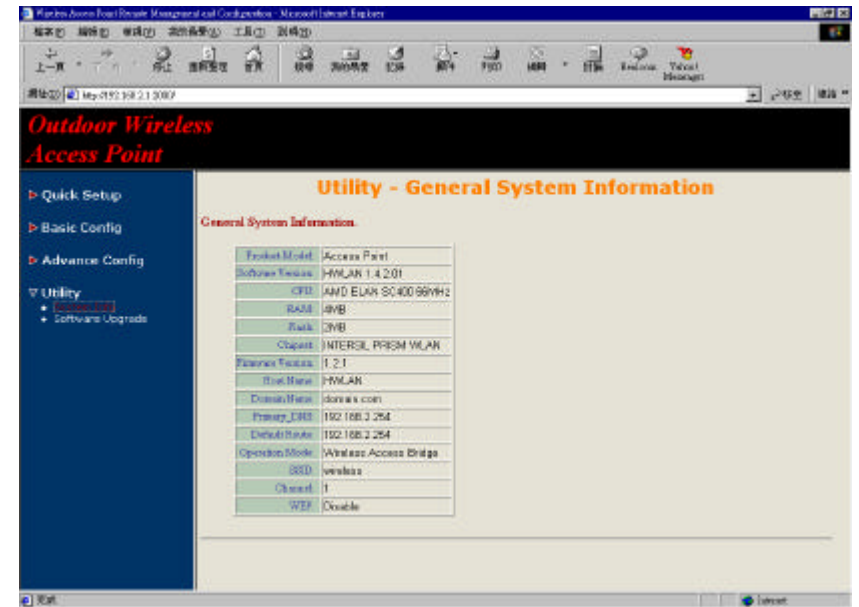

Figure 3-21

3.11.2 Software Upgrade

1. Click **Utility**, select **Software Upgrade** page (as shown in **Figure 3-22**), and then you can use TFTP to upgrade your AP. In here, you must specify the **TFTP server IP** and select which file you want to upgrade it (**Program image**, **Web image**), then click **OK** button to start the TFTP upgrade process.
2. If the upgrade process is success, the AP will apply the new settings and start rebooting right away.

Hint: You must set up a TFTP server and this server must contain one newest image.

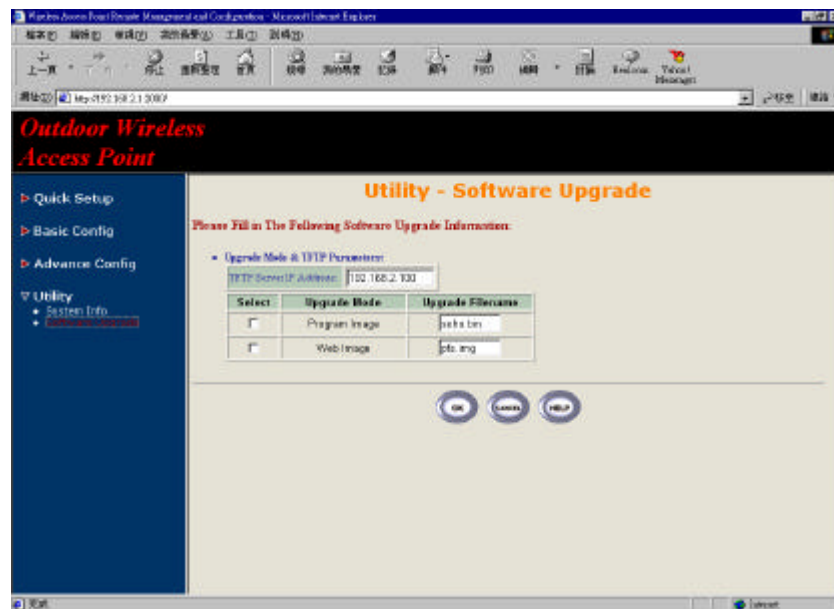

Figure 3-22

Chapter 4. Telnet Configuration

The AP is designed to operate as shipped from the factory without any special set-up. However, it has many options and parameters that can be changed if users have special requirements. Most of the management functions can be accessed using TCP/IP protocol, it also configured by Telnet/Console.

The operator can have to configure the AP through using a Telnet session on a wired LAN attached computer. To use the Telnet session, you can simply open a Telnet window using the IP address that has been assigned to the AP.

1. Click **Start** button, select **Run** to open the **Run** dialog box. Enter **telnet 192.168.2.1** (default terminal type of Telnet is VT100, default IP address of the AP is **192.168.2.1**). Then click **OK** as shown in **Figure 4-1**.

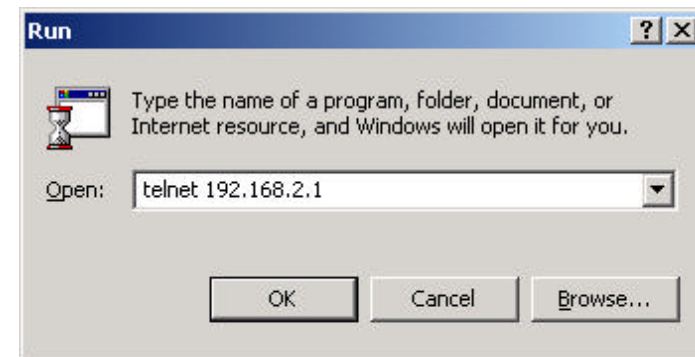

Figure 4-1.

2. In the **Telnet** window, enter the **User Name** and **User Password** as shown in **Figure 4-2** (default User Name and User Password is **user1** and **test**) to see the main screen of Telnet user interface as shown in **Figure 4-3**.

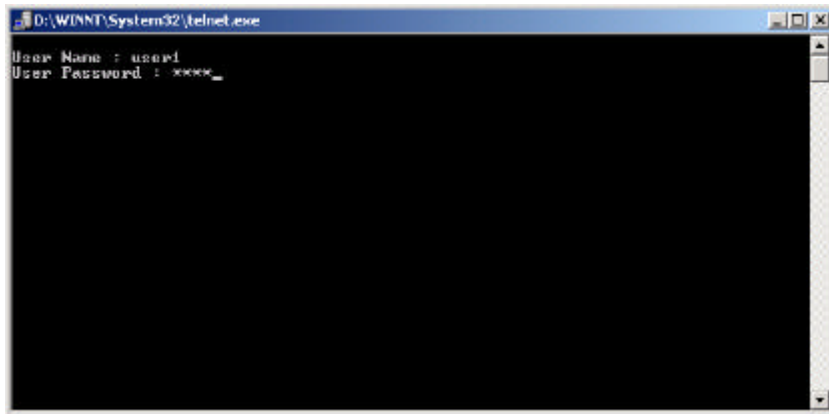

Figure 4-2

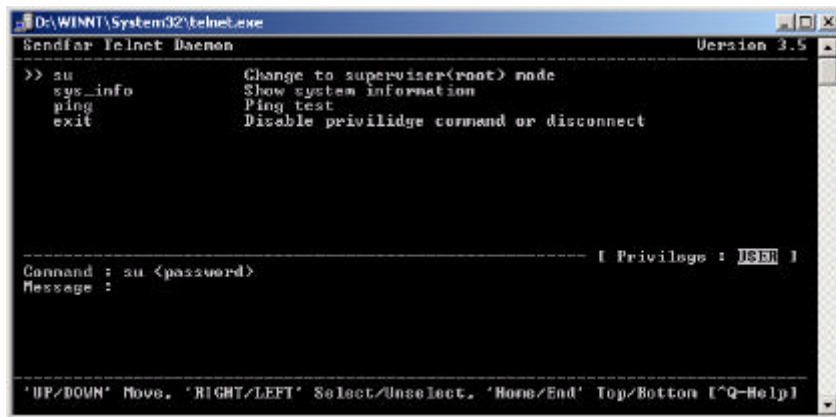

Figure 4-3

3. The structure of menu tree is shown in **Figure 4-4**. Users can use the following keys to select the parameter you want to change or add. The definition of the parameters is described in **Table 4-1** to **Table 4-14**.
- **Up/Down or i/k key**: move the cursor up/down to the specific item.
 - **Right or l or Enter key**: select the item or enter to sub-menu.
 - **Left or j key**: return to previous menu page.
 - **Home or Ctrl-A**: move the cursor to the first item of the menu page.
 - **End or Ctrl-E**: move the cursor to the last item of the menu page.
 - **Ctrl-Q or F1**: Show the help page.

Hint 1: * denote the function is displayed after **enable configuration mode** is enabled.

Hint 2: In item **su**, type default password **root** to enter the supervisor configuration mode.

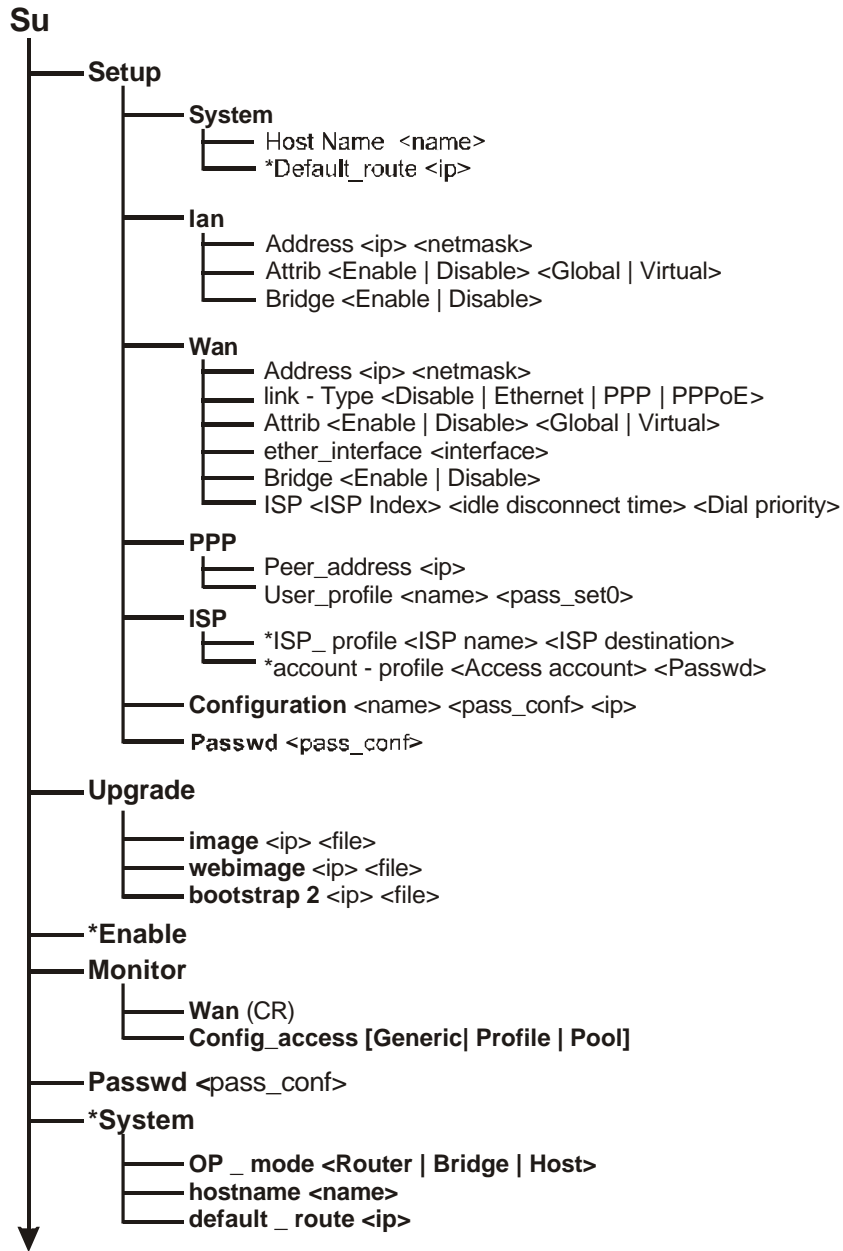

Figure 4-4

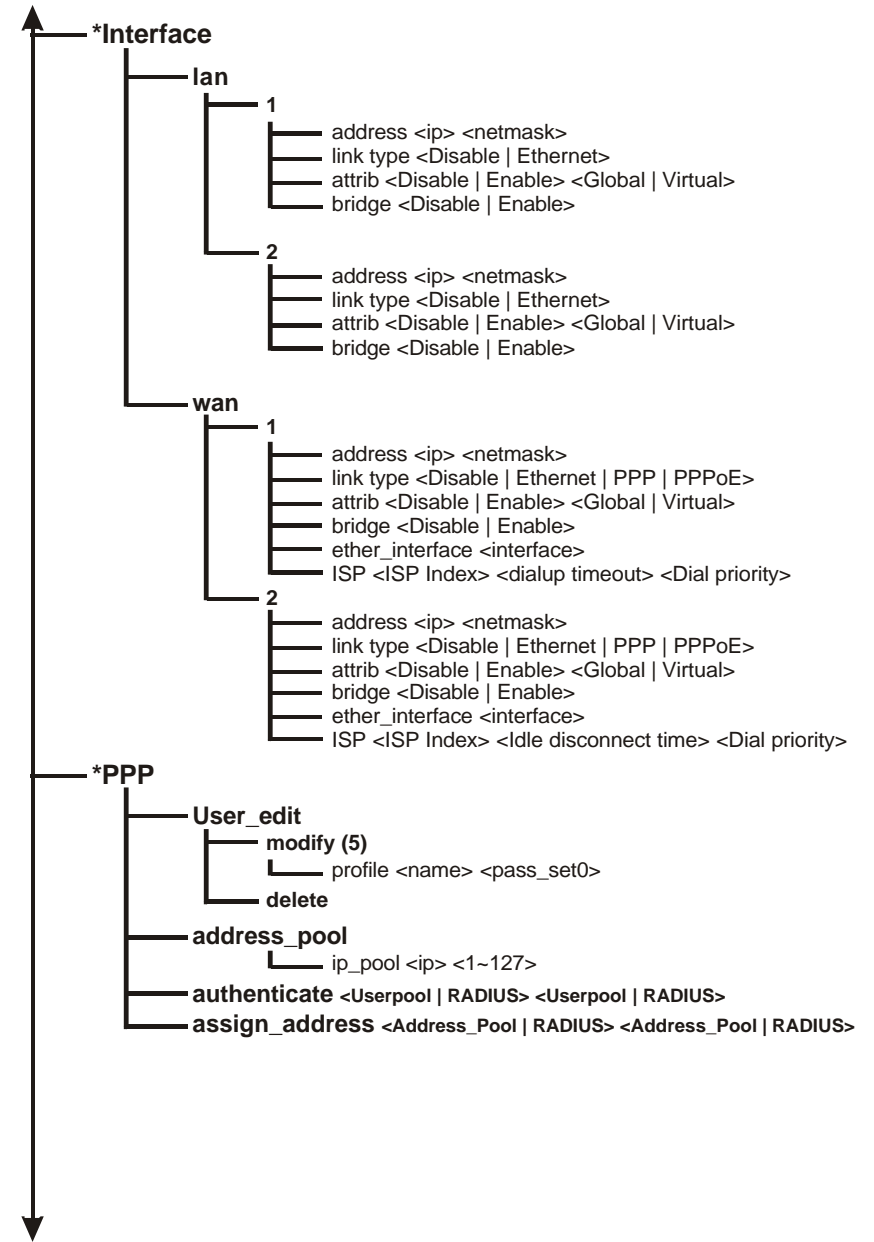

Figure 4-4

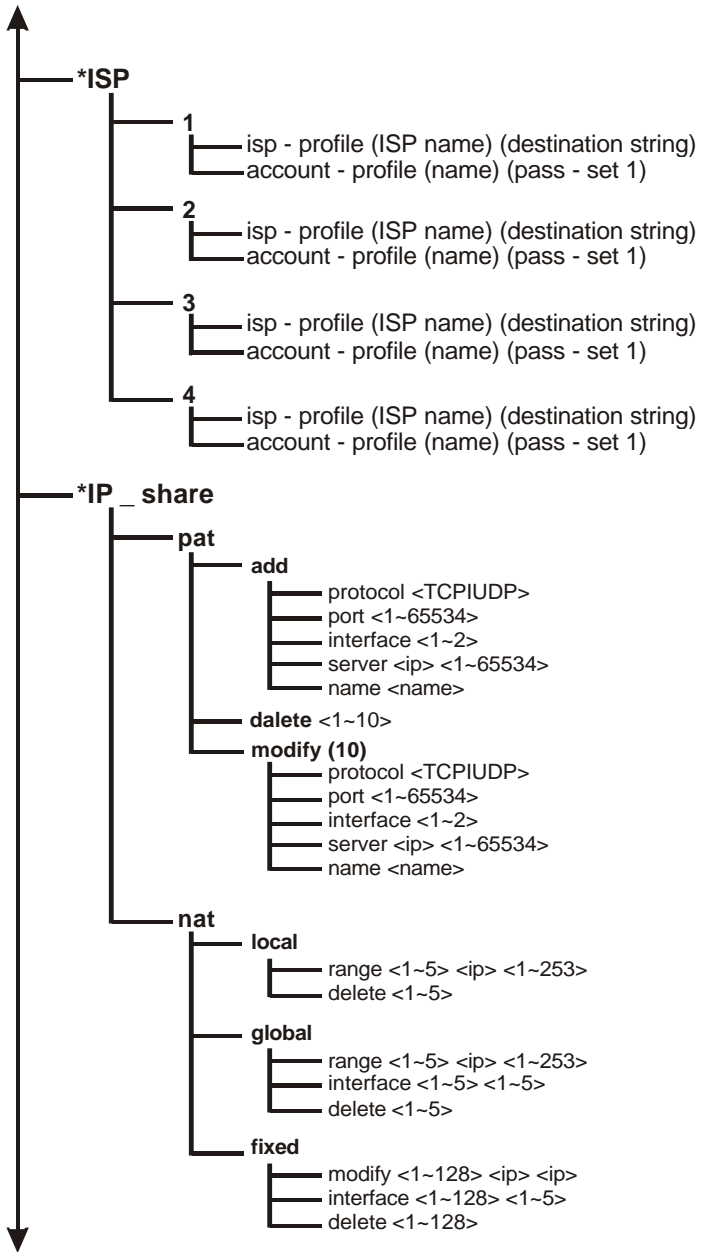

Figure 4-4

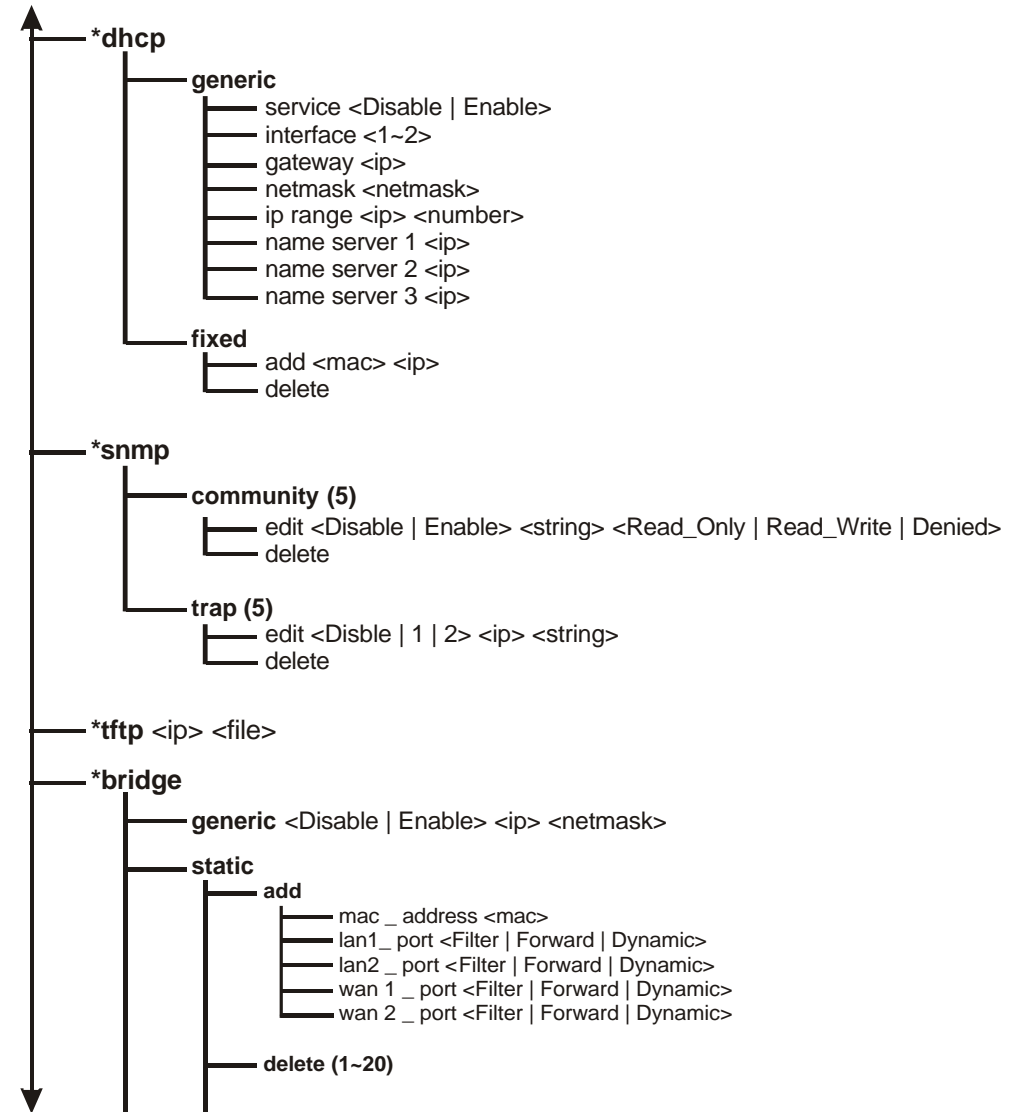

Figure 4-4

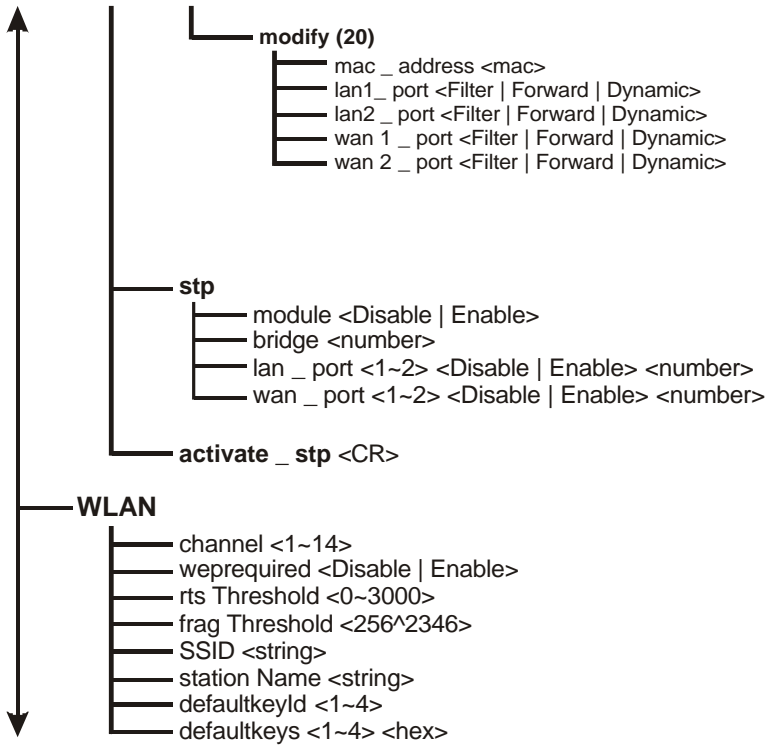

Figure 4-4

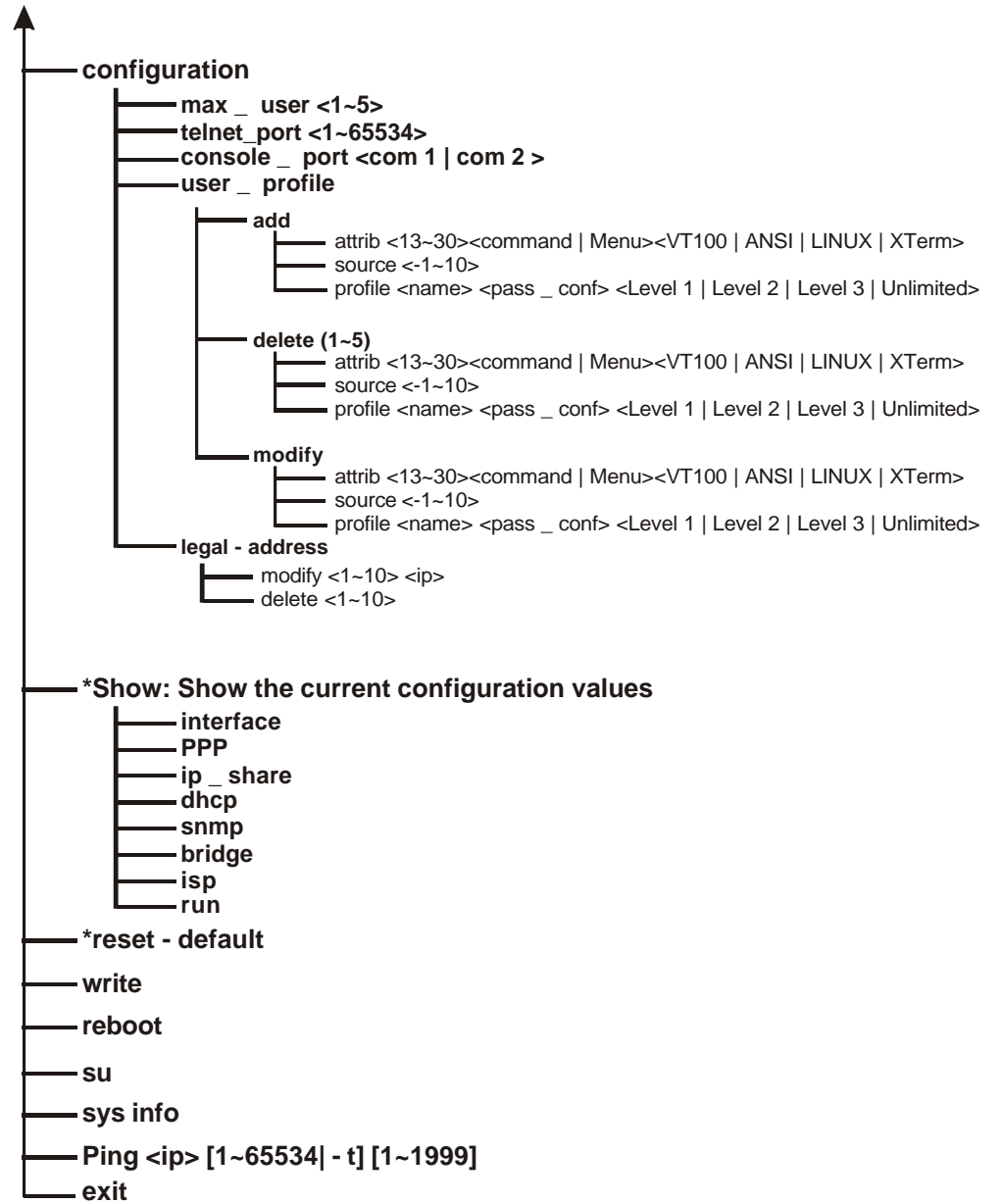

Figure 4-4

Chapter 5. Specifications

General

Compatibility	Fully interoperable with IEEE802.11b compliant products
Regulation Certifications	FCC Part 15, ETSI 300/328
Power Supply	Output: -48 VDC/0.7A (power over Ethernet) Input: 100/240 VAC; 50/60 Hz
Temperature Range	-20 to 70 (operating) -40 to 80 (storage)
Humidity (non-condensing)	5% to 95% typical
Surge Arrester	20KA Surge Current

Radio

Frequency Band	2.4 – 2.484 GHz
Radio Type	Direct Sequence Spread Spectrum (DSSS)
Modulation	CCK (11, 5.5Mbps) DQPSK (2Mbps) DBPSK (1Mbps)
Operation Channels	11 for North America, 14 for Japan, 13 for Europe, 2 for Spain, 4 for France
RF Output Power	28dBm typically
RF Connector	Proprietary N-type (Reverse Polarity)

Network Information

Ethernet Interface	10-Base T (RJ45)
IP Sharing	Supports NAT
Roaming	Seamless roaming (IEEE802.11b compliant)
Security	64/128-bit WEP data encryption

Management

Local Configuration	RS-232 serial port
Remote Configuration	HTTP, Telnet, SNMP
Firmware Upgrade	Upgrade via Serial Interface or TFTP
IP Auto-configuration	Supports DHCP server

Physical Specifications

Dimensions	245(L) mm x 200(W) mm x 70(H) mm
Weight	2100 g

Chapter 6. Default Settings

B-1 Basic Configuration

B-1-1 System (as shown in Table B-1)

Parameter	Description	Default Value
Supervisor ID	Supervisor's identity code	root
Supervisor Password	Supervisor's password	root
Password Confirm	Confirm the password again	root
Host Name	Host name for the AP	HWLAN
Domain Name	Domain name for the AP	domain.com
Default Route IP Address	IP address of the gateway for default route when TCP/IP filtering	192.168.2.254
DNS Server Parameter		
DNS Server 1 Address	IP addresses of the DNS Servers of your Local ISP	192.168.2.254
DNS Server 2 Address		
DNS Server 3 Address		

Table B-1

B-1-2 Interface (as shown in Table B-2)

Parameter	Description	Default Value
Interface No.	No.1 Wireless Interface No.2 Ethernet Interface No.3 PPPoE Interface No.4 PPP Interface	Note: 1. No.3 is effective only when No.2 is Active. 2. Default No.3 & No. 4 is Disable
Status	Enable or disable the Corresponding interface	Active
IP address	IP address of the corresponding interface. The user can use a LAN attached (wired or wireless) computer to configure the AP	No.1: 192.168.1.1 No.2: 192.168.2.1 No.3: 192.168.3.1 No.4: 192.168.4.1

	through using a web browser or telnet program on a LAN attached computer.	
Net Mask	Consists of four sets of digits that help divide a network into sub-networks and simplify routing and data transmission	No.1:255.255.255.0 No.2:255.255.255.0 No.3:255.255.255.0 No.4:255.255.255.0
NAT(PAT)	Select the network type for NAT function. OFF <-> ON: NAT enable ON <-> ON: NAT disable OFF <-> OFF: NAT disable	No.1: OFF No.2: OFF No.3: ON No.4: OFF
Bridging	Shows the corresponding interface that joins to form a bridge	No.1: Not Join No.2: Not Join No.3: Not Join No.4: Not Join
ISP Index	Select the ISP index given in the ISP pool	ISP1
IPCP	Select IP Control Protocol (Static or dynamic) for PPP/PPPoE interface	Dynamic
Idle Time Out (min)	Cancel the dial if not connected within this period	3min
Dial Priority	Set the dial-up priority of the corresponding interface	PPPoE: 3 PPP: 2
Dial-in	Enable or disable the dial-in function of the corresponding interface	Disable
Dial-in Authentication	Selects the authentication protocol for the corresponding dial-in interface	None

Table B-2

B-1-3 Telnet/Console (as shown in Table B-3)

Parameter	Description	Default Value
Maximum User	Set the maximum number of the users that can login the AP through Telnet session at the same time	2
Telnet Port	The port number for Telnet Program	23
Console Port	The communication port that is used to login the AP	COM1
ID Number	Index for Telnet users	1
User Name	User name for Telnet session	user1
Privilege	Select the user's privilege level for Telnet session	Unlimited
Max. Screen Line	Set the maximum number of lines displayed on the screen	24
Show Mode	Select the type of display for Telnet session (Command/Menu mode)	Menu
Keyboard Type	Select the type of the keyboard for Telnet session	VT100

Table B-3

B-1-4 Telnet/Console (as shown in Table B-4)

Parameter	Description	Default Value
ISP Name	Name of Internet Service Provider	ISP-1
Phone Number	The phone number that is used to dial up your ISP Note: The phone number must enter direct line phone number	12345678
Username	The user name used to login ISP	user

Password	The password used to login ISP	pass
----------	--------------------------------	------

Table B-4**B-1-5 DHCP (as shown in Table B-5)**

Parameter	Description	Default Value
DHCP Client Setting	Enable or disable the specified interface to obtain an IP address automatically	Disable
Trigger DHCP Service	Enable or disable automatic IP address assignment to wireless stations	Disable
Default Gateway	IP address of the gateway for default route when TCP/IP filtering	192.168.1.1
Net Mask	Consists of four sets of digits that help divide a network into sub-networks and simplify routing and data transmission	255.255.255.0
Name Server	IP address of the DNS host	192.168.2.254
DHCP Start IP	IP starting address	192.168.1.240
DHCP End IP	IP ending address	192.168.1.254
Interface	Select the interface to provide DHCP service	H WLAN
Fixed Host Entry	Define a fixed Ethernet-to-IP address mapping to limit the client station with the Ethernet address to get the IP address	

Table B-5**B-1-6 Virtual Server Mapping (as shown in Table B-6)**

Parameter	Description	Default Value
Service Name	Specify the service for public	NULL

	access	
Protocol	Select a protocol for public access	NULL
Public Access – Interface	Select an interface for public access	NULL
Public Access – Port Number	Specify the port number of the interface for public access	NULL
Virtual Server – IP Address	Specify the IP address of the virtual server	NULL
Virtual Server – Port Number	Specify the port number of internal virtual server	NULL

Table B-6**B-1-7 NAT (Network Address Translation) (as shown in Table B-7)**

Parameter	Description	Default Value
Local IP Address Pool – Base IP Address	IP starting address of local IP address	NULL
Local IP Address Pool – Count	Number of local IP address	NULL
Global IP Address Pool – Base IP Address	IP starting address of global IP address	NULL
Global IP Address Pool – Count	Number of global IP address	NULL
Global IP Address Pool – Interface	Specify the interface as global IP address	NULL
Fixed IP Address Mapping – Local/Global IP Address	Define a local and global IP address pair for network address translation	NULL
Fixed IP Address Mapping – Interface	Specify the interface for network address translation	NULL

Table B-7

B-1-8 Wireless LAN (as shown in Table B-8)

Parameter	Description	Default Value
Regulatory Domain	Define the regulatory domain to which this NIC may be deployed	1
Channel	The operating radio frequency channel for the AP	11
RTS Threshold	Set RTS (Request To Send) threshold value	250
Fragmentation Threshold	Set fragmentation threshold value	1600
SSID	Wireless LAN service area identifier of the AP (case sensitive)	wireless
Station Name	Shows the name of the AP	ap
WEP	Enable or disable 64-bit WEP (Wired Equivalent Privacy) key to encrypt data	Disable
Default Key	Select a WEP key to encrypt each frame transmitted from the radio using one the of the Keys from the Key Panel	1
Key Panel	When you use WEP to communicate with the other wireless clients, all the wireless devices in this network must have the same encryption key or pass phrase. Note: each key must consist of hex digits, it means that only digit 0 -9 and letters A-F are valid entries. If entered incorrectly, program will not write keys to a driver.	

Table B-8

B-1-9 Bridging (as shown in Table B-9)

Parameter	Description	Default Value
Bridging Function	Enable or disable bridging Function	Enable
IP Address	IP Address of the AP when in Bridging mode. The user can use a LAN attached (wired or wireless) computer to configure the AP through using a web browser or telnet program on a LAN attached computer.	192.168.2.1
Subnet Mask	Consists of four sets of digits that help divide a network into sub-networks and simplify routing and data transmission	255.255.255.0
Operation mode	Enable or disable the operation mode	Enable Enable Disable Disable
MAC Address	MAC address to be considered in forward/filter policy	00-00-00-00-00-00
Interface	Select Filter(always block the frames), Forward(always forward the frames) or Dynamic(forward the frames if the MAC address exists) to the corresponding interface	1. Filter 2. Filter 3. --- 4. ---

Table B-9**B-1-10 SNMP Community (as shown in Table B-10)**

Parameter	Description	Default Value
Validity	Enable or disable the function of the corresponding community index	Enable
Access Right	Select the access right (Deny/Read/Write/Create) for SNMP Manager	Read
Community	Specify the type of community (public or private) for SNMP Manager	Public

Table B-10**B-1-11 SNMP Trap (as shown in Table B-11)**

Parameter	Description	Default Value
Index	Enable or disable the activity of the corresponding community	Enable
Version	Select or disable the SNMP Version Version 1: MIB1 Version 2: MIB2	Version1
IP Address	Specify the IP address of the SNMP Manager for SNMP Trap Report	192.168.2.100
Community	Specify the type of community (public or private) for SNMP Manager	Public

Table B-11

B-1-12 Software Upgrade (as shown in Table B-12)

Parameter	Description	Default Value
TFTP Server IP Address	Specify the IP address of the TFTP server to upgrade the firmware of the AP	192.168.2.100
Upgrade Filename	Specify the filename of requested firmware stored in TFTP server	soho.bin

Table B-12**Chapter 7. Regulatory Compliance Information*****Radio Frequency Interference Requirements***

This device complies with Part 15 of FCC Rules and Canada RSS-210.

Operation is subject to the following conditions:

This device may not cause harmful interference.

This device must accept any interference received, including interference that may cause undesired operation.

Radiation Exposure Statement

This equipment complies with FCC radiation exposure limits set forth for an uncontrolled environment. This equipment should be installed and operated with minimum distance 20 cm between the radiator & your body.

This transmitter must not be co-located or operating in conjunction with any other antenna of transmitter.

Interference Statement

This equipment has been tested and found to comply with the limits for a Class B digital device pursuant to Part 15 of the FCC Rules and Regulation. These limits are designed to provide reasonable protection against harmful interference in a residential installation. This equipment generates, uses, and can radiate radio frequency energy and, if not installed and used in accordance with the instruction manual, may cause harmful interference to nearby TV' s, VCR' s, radio, computers, or other electronic devices. To minimize or prevent such interference, this equipment should not be placed or operated near these devices. If interference is experienced, moving the equipment away from them will often reduce or eliminate the interference.

However, there is no guarantee that interference will not occur in a particular installation. If the equipment does cause harmful interference to radio or television reception, which can be determined by turning the equipment off and on, the user is encouraged to try to correct the interference by one or more of the following measures:

Re-orient or relocate the receiving antenna.

Increase the separation between the equipment and receiver.

Connect the equipment into an outlet on a circuit different from that which the receiver is connected.

Consult the dealer or an experienced radio/TV technician for help.

Information to User

The user manual or instruction manual for an intentional or unintentional radiator shall caution the user that changes or modifications not expressly approved by the party responsible for compliance could void the user's authority to operate the equipment.

Federal Communication Commission Interference Statement

This equipment has been tested and found to comply with the limits for a Class B digital device, pursuant to Part 15 of the FCC Rules. These limits are designed to provide reasonable protection against harmful interference in a residential installation. This equipment generates, uses and can radiate radio frequency energy and, if not installed and used in accordance with the instructions, may cause harmful interference to radio communications. However, there is no guarantee that interference will not occur in a particular installation. If this equipment does cause harmful interference to radio or television reception, which can be determined by turning the equipment off and on, the user is encouraged to try to correct the interference by one of the following measures:

- Reorient or relocate the receiving antenna.
- Increase the separation between the equipment and receiver.
- Connect the equipment into an outlet on a circuit different from that to which the receiver is connected.
- Consult the dealer or an experienced radio/TV technician for help.

This device complies with Part 15 of the FCC Rules. Operation is subject to the following two conditions: (1) This device may not cause harmful interference, and (2) this device must accept any interference received, including interference that may cause undesired operation.

FCC Caution: Any changes or modifications not expressly approved by the party responsible for compliance could void the user's authority to operate this equipment.

IMPORTANT NOTE: FCC Radiation Exposure Statement: This equipment complies with FCC radiation exposure limits set forth for an uncontrolled environment. This equipment should be installed and operated with minimum distance 20cm between the radiator & your body. This transmitter must not be co-located or operating in conjunction with any other antenna or transmitter.