



849 NW STATE ROAD 45
NEWBERRY, FL 32669 USA
PH: 888.472.2424 OR 352.472.5500
FAX: 352.472.2030
EMAIL: INFO@TIMCOENGR.COM
[HTTP://WWW.TIMCOENGR.COM](http://WWW.TIMCOENGR.COM)

FCC PART 90 AND IC RSS-119, RSS-GEN TEST REPORT

APPLICANT	NORTHFIELD TELECOMMUNICATIONS, INC. d/b/a ADVANCED WIRELESS COMMUNICATIONS
ADDRESS	20809 KENSINGTON BLVD LAKEVILLE, MINNESOTA 55044 USA
FCC ID	Q9SAWR391V2
IC CERTIFICATION	4651A-AWR391V2
MODEL NUMBER	AWR391V2
PRODUCT DESCRIPTION	460-470 MHZ TRANSCEIVER
DATE SAMPLE RECEIVED	3/30/2009
DATE TESTED	4/2/2009
TESTED BY	Nam Nguyen
APPROVED BY	Mario de Aranzeta
TIMCO REPORT NO.	644AUT9TestReport.doc
TEST RESULTS	<input checked="" type="checkbox"/> PASS <input type="checkbox"/> FAIL

**THE ATTACHED REPORT SHALL NOT BE REPRODUCED EXCEPT IN FULL
WITHOUT THE WRITTEN APPROVAL OF TIMCO ENGINEERING, INC.**



Certificate # 0955-01



TABLE OF CONTENTS

GENERAL REMARKS	3
GENERAL INFORMATION	4
TEST PROCEDURES.....	5
RF POWER OUTPUT	6
MODULATION CHARACTERISTICS.....	7
AUDIO FREQUENCY RESPONSE.....	8
AUDIO INPUT VERSUS MODULATION.....	9
OCCUPIED BANDWIDTH	10
SPURIOUS EMISSIONS AT ANTENNA TERMINALS (CONDUCTED).....	13
FIELD STRENGTH OF SPURIOUS EMISSIONS	14
RECEIVER RADIATED SPURIOUS EMISSIONS.....	16
FREQUENCY STABILITY	17
TRANSIENT FREQUENCY BEHAVIOR.....	18
EMC EQUIPMENT LIST.....	22

APPLICANT: NORTHFIELD TELECOMMUNICATIONS, INC. d/b/a ADVANCED WIRELESS COMMUNICATONS
FCC ID: Q9SAWR391V2
IC: 4651A-AWR391V2
MODEL: AWR391V2
REPORT: Y:\N\NORTHFIELD_Q9S\644AUT9\644AUT9TestReport.doc

GENERAL REMARKS

The attached report shall not be reproduced except in full without the written permission of Timco Engineering Inc.

The test results relate only to the items tested.

Summary

The device under test does:

- fulfill the general approval requirements as identified in this test report
- not fulfill the general approval requirements as identified in this test report

Attestations

This equipment has been tested in accordance with the standards identified in this test report. To the best of my knowledge and belief, these tests were performed using the measurement procedures described in this report.

All instrumentation and accessories used to test products for compliance to the indicated standards are calibrated regularly in accordance with ISO 17025 requirements.



Testing Certificate # 0955-01

I attest that the necessary measurements were made, under my supervision, at:

Timco Engineering Inc.
849 NW State Road 45
Newberry, Fl 32669



Authorized Signatory Name:

Mario de Aranzeta C.E.T.
Compliance Engineer/ Lab. Supervisor

Date: 4/20/2009

APPLICANT: NORTHFIELD TELECOMMUNICATIONS, INC. d/b/a ADVANCED WIRELESS COMMUNICATONS
FCC ID: Q9SAWR391V2
IC: 4651A-AWR391V2
MODEL: AWR391V2
REPORT: Y:\N\NORTHFIELD_Q9S\644AUT9\644AUT9TestReport.doc

GENERAL INFORMATION

DUT Specification

DUT Description	460 – 470 MHZ TRANSCEIVER
FCC ID	Q9SAWR391V2
IC Certification	4651A-AWR391V2
Model Number	AWR391V2
Serial Number	N/A
Operating Frequency	460 – 470 MHz
Type of Emission	F3E
Modulation	FM
DUT Power Source	<input type="checkbox"/> 110–120Vac/50– 60Hz
	<input type="checkbox"/> DC Power 12V
	<input checked="" type="checkbox"/> Battery Operated Exclusively
Test Item	<input type="checkbox"/> Prototype
	<input checked="" type="checkbox"/> Pre-Production
	<input type="checkbox"/> Production
Type of Equipment	<input type="checkbox"/> Fixed
	<input type="checkbox"/> Mobile
	<input checked="" type="checkbox"/> Portable
Test Conditions	The temperature was 26°C with a relative humidity of 50%.
Modification to the DUT	None
Test Exercise	The DUT was placed in continuous transmit mode.
Applicable Standards	ANSI/TIA 603-C:2004, FCC CFR 47 Part 90, IC RSS-119, RSS-GEN
Test Facility	Timco Engineering Inc. at 849 NW State Road 45 Newberry, FL 32669 USA.

APPLICANT: NORTHFIELD TELECOMMUNICATIONS, INC. d/b/a ADVANCED WIRELESS COMMUNICATONS
 FCC ID: Q9SAWR391V2
 IC: 4651A-AWR391V2
 MODEL: AWR391V2
 REPORT: Y:\N\NORTHFIELD_Q9S\644AUT9\644AUT9TestReport.doc



TEST PROCEDURES

Power Line Conducted Interference: The procedure used was ANSI/TIA 603-C:2004 using a 50uH LISN. Both lines were observed with the DUT transmitting. The bandwidth of the spectrum analyzer was 10 kHz with an appropriate sweep speed.

Bandwidth 20 dB: The measurements were made with the spectrum analyzer's resolution bandwidth (RBW) = 1 MHz and the video bandwidth (VBW) = 3 MHz and the span set as shown on plot.

Power Output: The RF power output was measured at the antenna feed point using a peak power meter.

Antenna Conducted Emissions: The RBW = 100 kHz, VBW = 300 kHz and the span set to 10.0 MHz and the spectrum was scanned from 30 MHz to the 10th harmonic of the fundamental. Above 1 GHz the resolution bandwidth was 1 MHz and the VBW = 3 MHz and the span to 50 MHz.

Radiation Interference: The test procedure used was ANSI/TIA 603-C:2004 using an Agilent spectrum receiver with preselector. The bandwidth (RBW) of the spectrum receiver was 100 kHz up to 1 GHz and 1 MHz above 1 GHz with an appropriate sweep speed. The VBW above 1 GHz was 3 MHz. The analyzer was calibrated in dB above a micro volt at the output of the antenna.

APPLICANT: NORTHFIELD TELECOMMUNICATIONS, INC. d/b/a ADVANCED WIRELESS COMMUNICATONS
FCC ID: Q9SAWR391V2
IC: 4651A-AWR391V2
MODEL: AWR391V2
REPORT: Y:\N\NORTHFIELD_Q9S\644AUT9\644AUT9TestReport.doc

RF POWER OUTPUT

Rule Part No.: FCC Part 2.1046(a), IC RSS-119 4.1 and 5.4, RSS-GEN 4.8

Test Requirements:

Method of Measurement: RF power is measured conducted. With a nominal battery voltage, and the transmitter properly adjusted the RF output measures:

Test Setup Diagram:

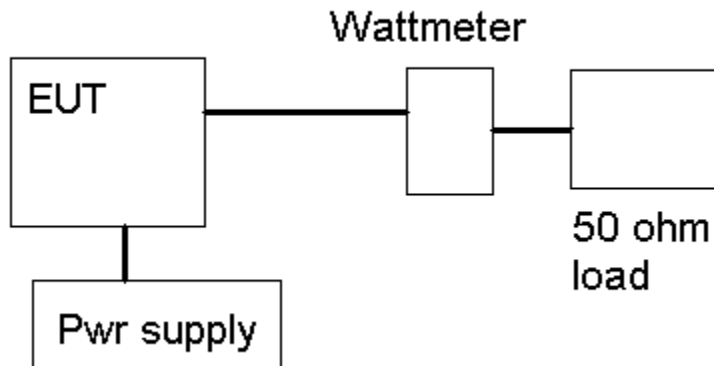

Test Data:

HIGH OUTPUT POWER:

465.56	dBm	dBm
	3.7V	4.2V
	29.2	30.1
	Watts	Watts
	0.84	1

Part 2.1033 (C)(8) DC Input into the final amplifier

FOR HIGH POWER SETTING INPUT POWER: $(3.7V)(1.39A) = 5.1$ Watts

APPLICANT: NORTHFIELD TELECOMMUNICATIONS, INC. d/b/a ADVANCED WIRELESS COMMUNICATONS
 FCC ID: Q9SAWR391V2
 IC: 4651A-AWR391V2
 MODEL: AWR391V2
 REPORT: Y:\N\NORTHFIELD_Q9S\644AUT9\644AUT9TestReport.doc



MODULATION CHARACTERISTICS

Part 2.1033(c)

Part 2.1033(c) (4) Type of Emission: 11K2F3E

FCC Part 90.209, IC RSS-119 5.5

FCC Part 90.207

Type of Emission: 11K2F3E

$$B_n = 2M + 2DK$$

$$M = 3000$$

$$D = 2500$$

$$K=1$$

$$B_n = 2(3000)+2(2500) = 11.0k$$

APPLICANT: NORTHFIELD TELECOMMUNICATIONS, INC. d/b/a ADVANCED WIRELESS COMMUNICATONS

FCC ID: Q9SAWR391V2

IC: 4651A-AWR391V2

MODEL: AWR391V2

REPORT: Y:\N\NORTHFIELD_Q9S\644AUT9\644AUT9TestReport.doc

AUDIO FREQUENCY RESPONSE

Rule Part No.: FCC Part 2.1047(a)(b), IC RSS-119 5.2

Test Requirements:

Method of Measurement:

The audio frequency response was measured in accordance with ANSI/TIA 603-C:2004. A curve or equivalent data showing the frequency response of the audio modulating circuit over a range of 100 – 5000Hz shall be submitted. The audio frequency response curve is shown below.

AUDIO FREQUENCY RESPONSE PLOT

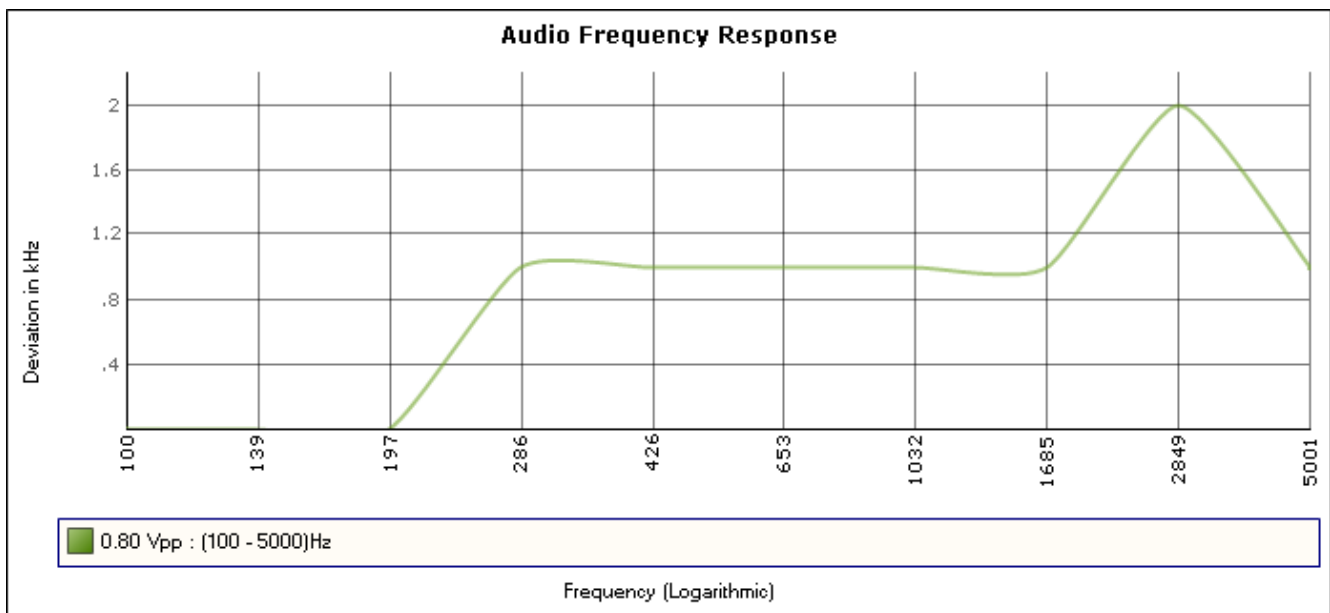

APPLICANT: NORTHFIELD TELECOMMUNICATIONS, INC. d/b/a ADVANCED WIRELESS COMMUNICATONS
 FCC ID: Q9SAWR391V2
 IC: 4651A-AWR391V2
 MODEL: AWR391V2
 REPORT: Y:\N\NORTHFIELD_Q9S\644AUT9\644AUT9TestReport.doc

AUDIO INPUT VERSUS MODULATION

Rule Part No.: FCC Part 2.1047(b) & 90, IC RSS-119 5.2

Test Requirements:

Method of Measurement: Modulation cannot exceed 100%, The audio input level needed for a particular percentage of modulation was measured in accordance with ANSI/TIA 603-C:2004. The audio input curves versus modulation are shown below. Curves are provided for audio input frequencies of 300, 1000, and 2500 Hz.

Test data:

Modulation Limiting Plot

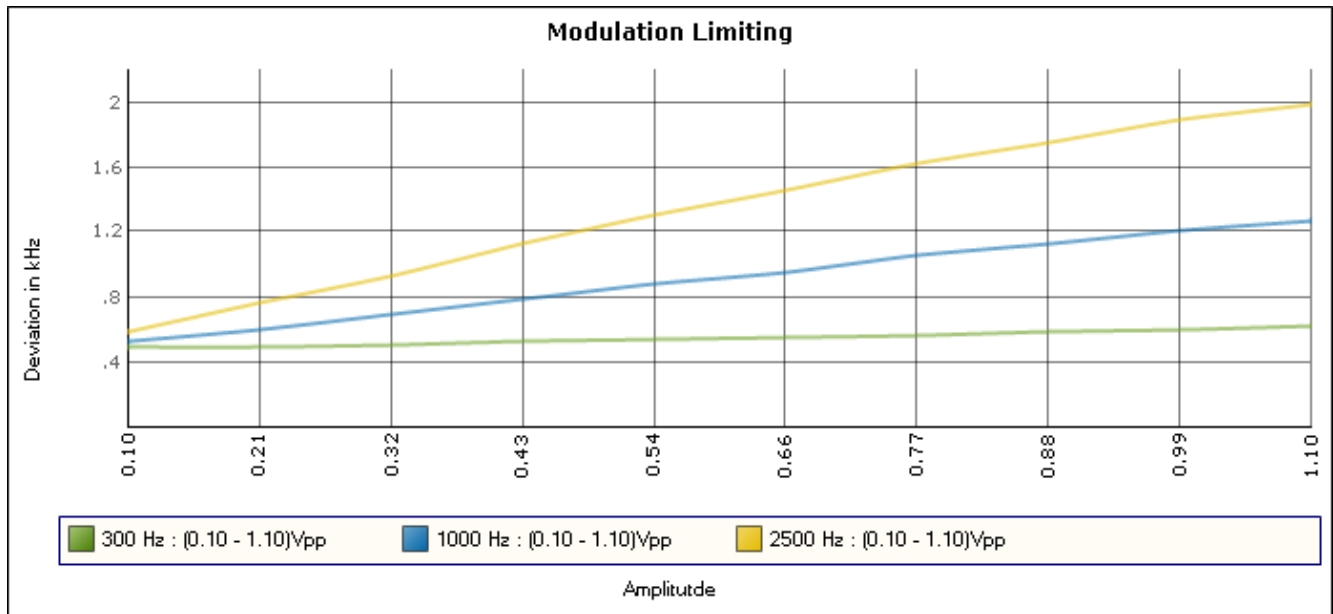

APPLICANT: NORTHFIELD TELECOMMUNICATIONS, INC. d/b/a ADVANCED WIRELESS COMMUNICATONS
 FCC ID: Q9SAWR391V2
 IC: 4651A-AWR391V2
 MODEL: AWR391V2
 REPORT: Y:\N\NORTHFIELD_Q9S\644AUT9\644AUT9TestReport.doc

OCCUPIED BANDWIDTH

FCC Part 2.1049(c), RSS-GEN 4.6 EMISSION BANDWIDTH FCC Part 90.210(b) RSS-119 4.2 25kHz Channel Spacing

Data in the plots show that on any frequency removed from the assigned frequency by more than 50%, but not more than 100%: At least 25dB. On any frequency removed from the assigned frequency by more than 100%, but not more than 250%: At least 35 dB. On any frequency removed from the assigned frequency by more than 250%, of the authorized bandwidth: At least $43 + 10\log(P)$ dB.

Part 90.210(c) 12.5kHz Channel Spacing Not Equipped with a Low Pass Filter

For transmitters that are not equipped with an audio low pass filter pursuant to S90.211 (b), the power of any emission must be attenuated below the un-modulated carrier output power as follows; (1) On any frequency removed from the center of the authorized bandwidth by a displacement frequency (f_d in kHz) of more than 5 kHz but not more than 10 kHz: At least $83 \log(f_d/5)$ dB; (2) ON any frequency removed from the center of the authorized bandwidth by a displacement frequency (f_d in kHz) of more than 10 kHz, but not more than 250% of the authorized bandwidth: At least $29 \log(f_d/11)$ dB or 50 dB, whichever is the lesser attenuation; (3) On any frequency removed from the center of the authorized bandwidth by more than 250% of the authorized bandwidth: At least $43 + 10 \log(P_0)$ dB.

Part 90.210(d) Emission Mask D - 12.5 kHz channel BW equipment.

For transmitters designed to operate with a 12.5 kHz channel bandwidth, any emission must be attenuated below the power (P) of the highest emission contained within the authorized bandwidth as follows:

- (1) On any frequency from the center of the authorized bandwidth f_0 to 5.625 kHz removed from f_0 : Zero dB.
- (2) On any frequency from the center of the authorized bandwidth by a displacement frequency (f_d in kHz) of more than 5.625 kHz but no more than 12.5 kHz: At least $7.27(f_d - 2.88 \text{ kHz})$ dB.
- (3) On any frequency removed from the center of the authorized bandwidth by a displacement frequency (f_d in kHz) of more than 12.5 kHz: At least $50 + 10\log(P)$ dB or 70 dB, whichever is the lesser attenuation.

Part 90.210(e) Emission Mask E - 6.25 kHz channel BW equipment.

For transmitters designed to operate with a 6.25 kHz bandwidth, any emission must be attenuated below the power (P) of the highest emission contained within the authorized bandwidth as follows:

- (1) On any frequency from the center of the authorized bandwidth f_0 to 3.0 kHz removed from f_0 : Zero dB.
- (2) On any frequency from the center of the authorized bandwidth by a displacement frequency (f_d in kHz) of more than 3.0 kHz but no more than 4.6 kHz: At least $30 + 16.67(f_d - 3.0 \text{ kHz})$ or $55 + 10 \log(P)$ or 65, whichever is the lesser attenuation.
- (3) On any frequency removed from the center of the authorized bandwidth by more than 4.6kHz: At least $55 + 10\log(P)$ dB or 65 dB, whichever is the lesser attenuation.

APPLICANT: NORTHFIELD TELECOMMUNICATIONS, INC. d/b/a ADVANCED WIRELESS COMMUNICATONS
FCC ID: Q9SAWR391V2
IC: 4651A-AWR391V2
MODEL: AWR391V2
REPORT: Y:\N\NORTHFIELD_Q9S\644AUT9\644AUT9TestReport.doc

OCCUPIED BANDWIDTH MEASUREMENT

Test procedure: ANSI/TIA-603-C:2004 para 2.2.11.

Test Setup Diagram:

OCCUPIED BANDWIDTH MEASUREMENT

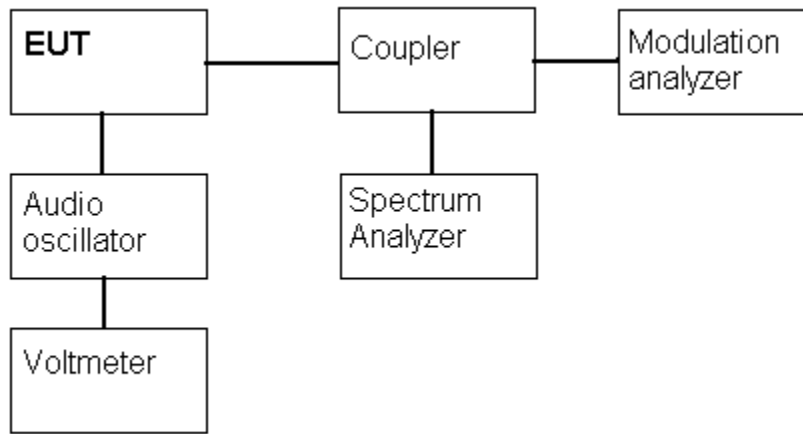

Test Data: See the plots below

APPLICANT: NORTHFIELD TELECOMMUNICATIONS, INC. d/b/a ADVANCED WIRELESS COMMUNICATONS
FCC ID: Q9SAWR391V2
IC: 4651A-AWR391V2
MODEL: AWR391V2
REPORT: Y:\N\NORTHFIELD_Q9S\644AUT9\644AUT9TestReport.doc

NOTES:

NORTHFIELD TELECOMMUNICATIONS, INC. - FCC ID: Q95-AW391
 OCCUPIED BANDWIDTH PLOT

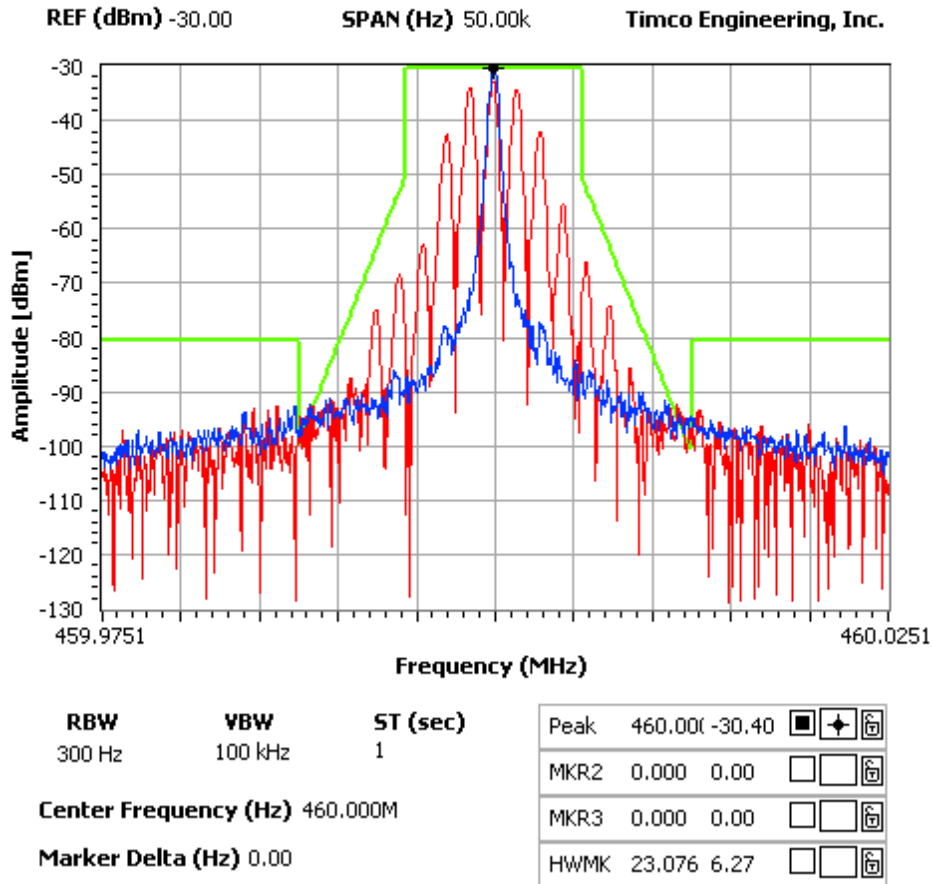

APPLICANT: NORTHFIELD TELECOMMUNICATIONS, INC. d/b/a ADVANCED WIRELESS COMMUNICATONS
 FCC ID: Q9SAWR391V2
 IC: 4651A-AWR391V2
 MODEL: AWR391V2
 REPORT: Y:\N\NORTHFIELD_Q9S\644AUT9\644AUT9TestReport.doc



SPURIOUS EMISSIONS AT ANTENNA TERMINALS (CONDUCTED)

Rule Part No.: FCC Part 2.1051(a), RSS-GEN 7.1.4

Method of Measurement: The carrier was modulated 100% using a 2500 Hz tone. The spectrum was scanned from 30 MHz to at least the 10th harmonic of the fundamental. The measurements were made in accordance with standard ANSI/TIA 603-C:2004.

Test Data: Not applicable. DUT has fixed antenna.

APPLICANT: NORTHFIELD TELECOMMUNICATIONS, INC. d/b/a ADVANCED WIRELESS COMMUNICATONS
FCC ID: Q9SAWR391V2
IC: 4651A-AWR391V2
MODEL: AWR391V2
REPORT: Y:\N\NORTHFIELD_Q9S\644AUT9\644AUT9TestReport.doc

FIELD STRENGTH OF SPURIOUS EMISSIONS

Rule Parts. No.: FCC Part 2.1053, RSS-GEN 4.9

Requirements: $50+10\log(1) = 50$ dB

METHOD OF MEASUREMENT: The tabulated data shows the results of the radiated field strength emissions test. The spectrum was scanned from 30 MHz to at least the tenth harmonic of the fundamental. This test was conducted per ANSI/TIA 603-C:2004 using the substitution method. Measurements were made at the test site of TIMCO ENGINEERING, INC. located at 849 NW State Road 45, Newberry, FL 32669.

Test Setup Diagram:

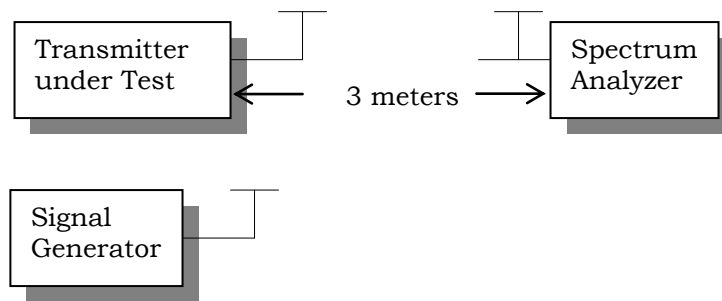

APPLICANT: NORTHFIELD TELECOMMUNICATIONS, INC. d/b/a ADVANCED WIRELESS COMMUNICATONS
FCC ID: Q9SAWR391V2
IC: 4651A-AWR391V2
MODEL: AWR391V2
REPORT: Y:\N\NORTHFIELD_Q9S\644AUT9\644AUT9TestReport.doc

Test Data:

Emission Frequency MHz	Ant. Polarity	dB Below Carrier (dBc)	Emission Frequency MHz	Ant. Polarity	dB Below Carrier (dBc)
461.56	V	0	465.56	V	0.00
923.12	V	67.80	931.12	V	65.22
1384.68	V	77.14	1396.68	V	74.58
1846.24	V	79.89	1862.24	V	74.07
2307.80	V	75.32	2327.80	V	69.75
2769.36	V	67.75	2793.36	V	58.93
3230.92	V	79.98	3258.92	V	70.96
3692.48	V	77.52	3724.48	V	74.22
4154.04	V	79.39	4190.04	V	79.34
4615.60	V	78.78	4655.60	V	80.94

Emission Frequency MHz	Ant. Polarity	dB Below Carrier (dBc)
470.02	V	0.00
940.04	V	66.64
1410.06	V	74.12
1880.08	V	69.96
2350.10	V	63.78
2820.12	V	57.40
3290.14	V	77.23
3760.16	V	78.01
4230.18	V	81.28
4700.20	V	80.60

APPLICANT: NORTHFIELD TELECOMMUNICATIONS, INC. d/b/a ADVANCED WIRELESS COMMUNICATONS
 FCC ID: Q9SAWR391V2
 IC: 4651A-AWR391V2
 MODEL: AWR391V2
 REPORT: Y:\N\NORTHFIELD_Q9S\644AUT9\644AUT9TestReport.doc



RECEIVER RADIATED SPURIOUS EMISSIONS

Rule Parts. No.: FCC Part 15.109, RSS-GEN 4.10, 6

Requirements: 30-88 MHz 40.0 dBμV/m measured at 3 meters
 88-216 MHz 43.5 dBμV/m
 216-960 MHz 46.0 dBμV/m
 ABOVE 960 MHz 54.0 dBμV/m

TEST DATA:

Tuned Frequency MHz	Emission Frequency MHz	Meter Reading dBμV	Ant. Pol	Coax Loss dB	Correction Factor dB/m	Field Strength dBμV/m	Margin dB
461.6	440.21	4.1	H	1.24	17.40	22.74	23.26
461.6	440.21	5.5	V	1.24	16.82	23.56	22.44
461.6	880.42	4.2	H	1.94	23.70	29.84	16.16
461.6	880.42	4.4	V	1.94	23.10	29.44	16.56
461.6	1,320.63	9.8	V	2.36	25.10	37.26	16.74
461.6	1,760.84	8.8	V	2.71	27.17	38.68	15.32
466.6	444.21	5.4	H	1.24	17.36	24.00	22.00
466.6	444.21	6.2	V	1.24	17.18	24.62	21.38
466.6	888.42	4.3	V	1.94	23.10	29.34	16.66
466.6	888.42	4.8	H	1.94	23.78	30.52	15.48
466.6	1,332.63	9.6	H	2.37	25.13	37.10	16.90
466.6	1,776.84	8.6	H	2.72	27.26	38.58	15.42
470.0	448.67	4.7	H	1.25	17.31	23.26	22.74
470.0	448.67	5.8	V	1.25	17.58	24.63	21.37
470.0	897.34	4.8	H	1.95	23.87	30.62	15.38
470.0	897.34	5.0	V	1.95	23.10	30.05	15.95
470.0	1,346.01	9.9	H	2.38	25.17	37.45	16.55
470.0	1,794.68	9.1	V	2.74	27.37	39.21	14.79
470.0	2,243.35	8.3	V	3.07	28.75	40.12	13.88
470.0	2,243.35	8.7	H	3.07	28.75	40.52	13.48

APPLICANT: NORTHFIELD TELECOMMUNICATIONS, INC. d/b/a ADVANCED WIRELESS COMMUNICATONS
 FCC ID: Q9SAWR391V2
 IC: 4651A-AWR391V2
 MODEL: AWR391V2
 REPORT: Y:\N\NORTHFIELD_Q9S\644AUT9\644AUT9TestReport.doc

FREQUENCY STABILITY

Rule Parts. No.: FCC Part 2.1055, Part 90.213, RSS-119 5.3, RSS-GEN 7.2.4

Requirements:

Temperature range requirements: -30 to +50° C. = ±2.5 PPM
Voltage Variation +, -15%

Method of Measurements: ANSI/TIA 603-C:2004

Test Data:

Assigned Frequency (Ref. Frequency) (MHz)		465.562937
Temperature (°C)	Frequency (MHz)	Frequency Stability (PPM)
-30	465.564093	2.48
-20	465.564032	2.35
-10	465.563843	1.95
0	465.563482	1.17
+10	465.563251	0.67
+20	465.562931	-0.01
+30	465.562639	-0.64
+40	465.562677	-0.56
+50	465.562528	-0.88

Assigned Frequency (Ref. Frequency) (MHz)		
Battery (%)	Frequency (MHz)	Frequency Stability (PPM)
-15%	465.562742	-0.42
+15%	465.562945	0.02

APPLICANT: NORTHFIELD TELECOMMUNICATIONS, INC. d/b/a ADVANCED WIRELESS COMMUNICATONS
 FCC ID: Q9SAWR391V2
 IC: 4651A-AWR391V2
 MODEL: AWR391V2
 REPORT: Y:\N\NORTHFIELD_Q9S\644AUT9\644AUT9TestReport.doc

TRANSIENT FREQUENCY BEHAVIOR

FCC Part 2.1055(a)(1)
FCC Part 90.214, IC RSS-119 5.8

REQUIREMENTS: Transmitters designed to operate in the 150-174 MHz and 421-512 MHz frequency bands must maintain transient frequencies within the maximum transient frequencies within the maximum frequency difference limits during the time intervals indicated:

Time Intervals	Maximum frequency difference	All Equipment	
		150-174 MHz	421-512 MHz

Transient Frequency Behavior for Equipment Designed to Operate on 25 kHz Channels

t ₁ ⁴	±25.0 kHz	5.0 ms	10.0 ms
t ₂	±12.5 kHz	20.0 ms	25.0 ms
t ₃ ⁴	±25.0 kHz	5.0 ms	10.0 ms

Transient Frequency Behavior for Equipment Designed to Operate on 12.5 kHz Channels

t ₁ ⁴	±12.5 kHz	5.0 ms	10.0 ms
t ₂	±6.25 kHz	20.0 ms	25.0 ms
t ₃ ⁴	±12.5 kHz	5.0 ms	10.0 ms

Transient Frequency Behavior for Equipment Designed to Operate on 6.25 kHz Channels

t ₁ ⁴	±6.25 kHz	5.0 ms	10.0 ms
t ₂	±3.125 kHz	20.0 ms	25.0 ms
t ₃ ⁴	±6.25 kHz	5.0 ms	10.0 ms

APPLICANT: NORTHFIELD TELECOMMUNICATIONS, INC. d/b/a ADVANCED WIRELESS COMMUNICATONS
 FCC ID: Q9SAWR391V2
 IC: 4651A-AWR391V2
 MODEL: AWR391V2
 REPORT: Y:\N\NORTHFIELD_Q9S\644AUT9\644AUT9TestReport.doc

12.5kHz

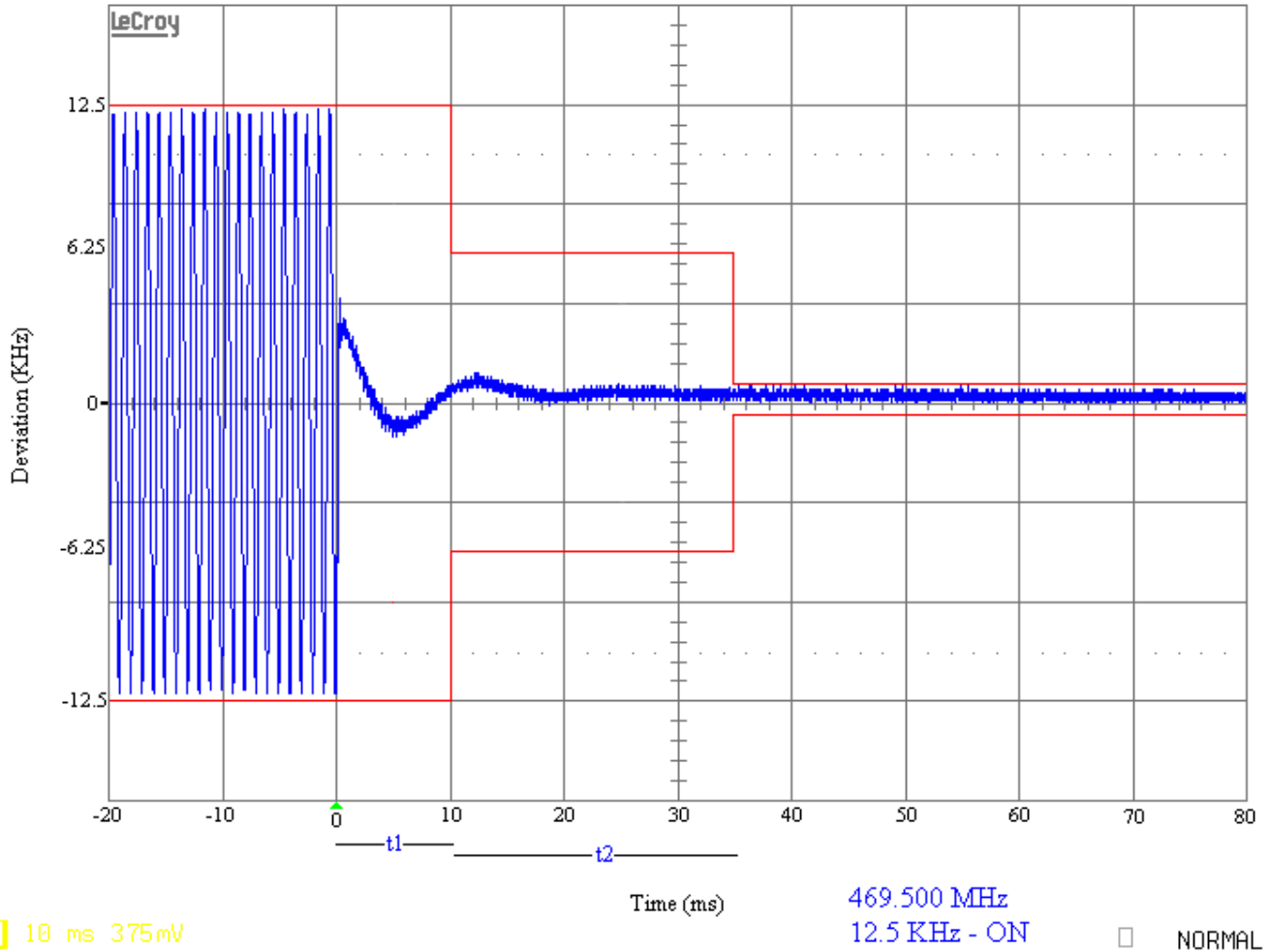

APPLICANT: NORTHFIELD TELECOMMUNICATIONS, INC. d/b/a ADVANCED WIRELESS COMMUNICATONS
 FCC ID: Q9SAWR391V2
 IC: 4651A-AWR391V2
 MODEL: AWR391V2
 REPORT: Y:\N\NORTHFIELD_Q9S\644AUT9\644AUT9TestReport.doc

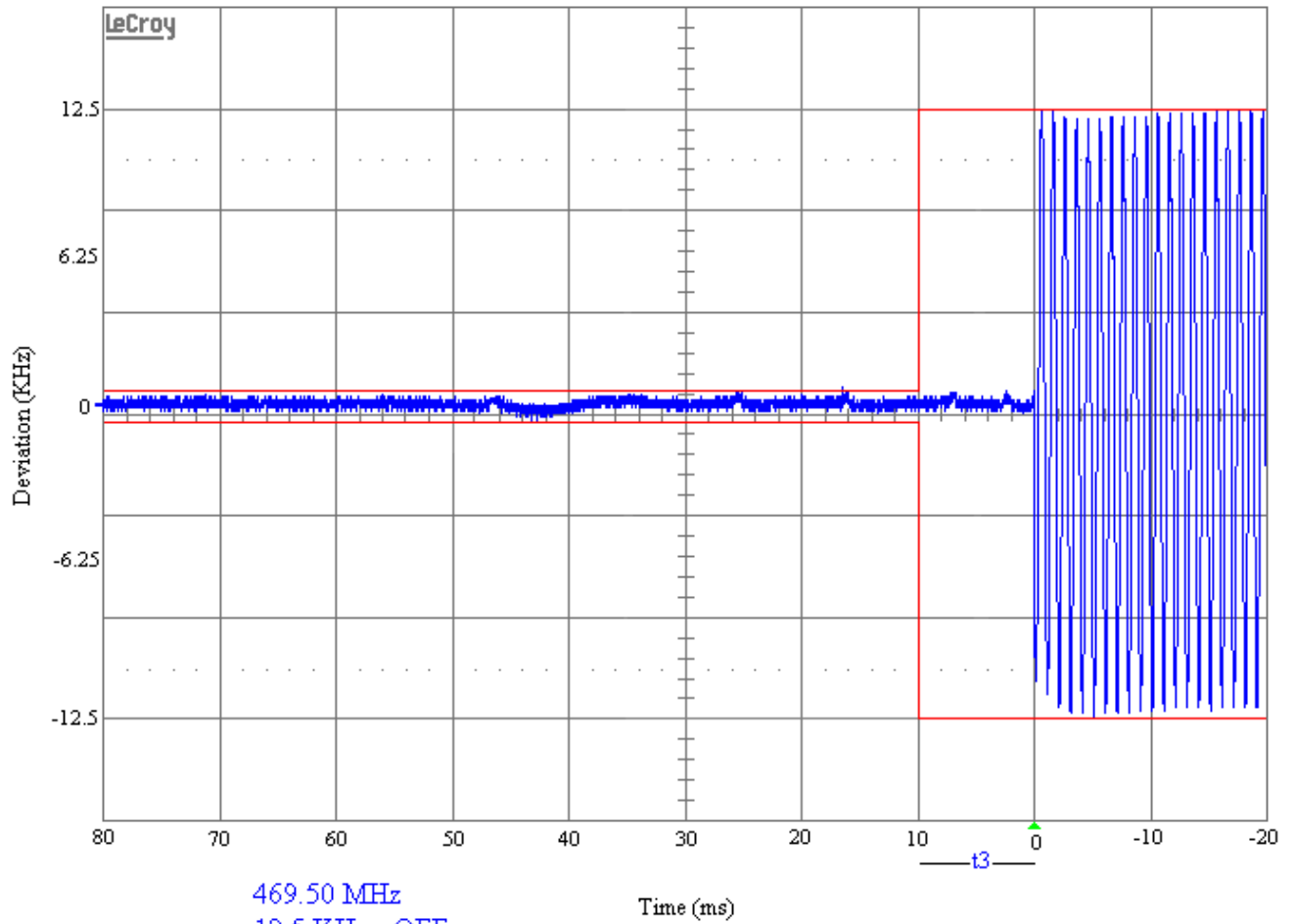

APPLICANT: NORTHFIELD TELECOMMUNICATIONS, INC. d/b/a ADVANCED WIRELESS COMMUNICATONS
 FCC ID: Q9SAWR391V2
 IC: 4651A-AWR391V2
 MODEL: AWR391V2
 REPORT: Y:\N\NORTHFIELD_Q9S\644AUT9\644AUT9TestReport.doc

TEST PROCEDURE: ANSI/TIA 603-C:2004 PARA 2.2.19

1. Using the variable attenuator the transmitter level was set to 40 dB below the test receivers maximum input level, then the transmitter was turned off.
2. With the transmitter off the signal generator was set 20dB below the level of the transmitter in the above step, this level will be maintained with the signal generator through-out the test.
3. Reduce the attenuation between the transmitter and the RF detector by 30 dB. With the levels set as above the transient frequency behavior was observed & recorded.

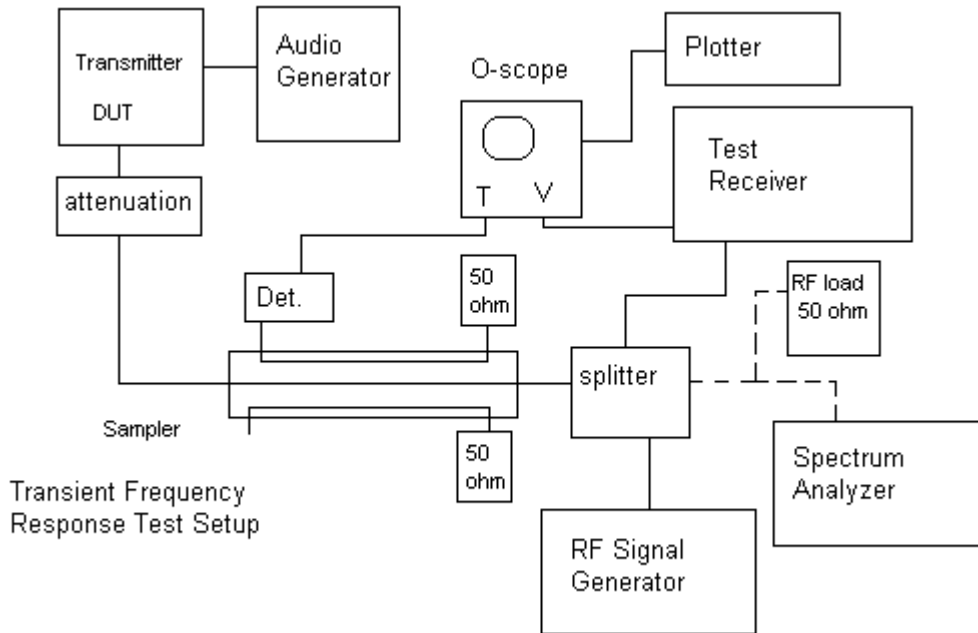

APPLICANT: NORTHFIELD TELECOMMUNICATIONS, INC. d/b/a ADVANCED WIRELESS COMMUNICATONS
 FCC ID: Q9SAWR391V2
 IC: 4651A-AWR391V2
 MODEL: AWR391V2
 REPORT: Y:\N\NORTHFIELD_Q9S\644AUT9\644AUT9TestReport.doc

EMC EQUIPMENT LIST

Device	Manufacturer	Model	Serial Number	Cal/Char Date	Due Date
3/10-Meter OATS	TEI	N/A	N/A	Listed 3/20/07	3/19/10
3-Meter OATS	TEI	N/A	N/A	Listed 2/5/09	2/5/12
3-Meter Semi-Anechoic Chamber	Panashield	N/A	N/A	Listed 5/11/07	5/11/10
AC Voltmeter	HP	400FL	2213A14499	CAL 3/23/09	3/23/11
Analyzer Tan Tower Quasi-Peak Adapter	HP	85650A	3303A01690	CAL 11/30/07	11/30/09
Analyzer Tan Tower RF Preselector	HP	85685A	3221A01400	CAL 11/30/07	11/30/09
Analyzer Tan Tower Spectrum Analyzer	HP	8566B Opt 462	3138A07786 3144A20661	CAL 11/30/07	11/30/09
Analyzer Tan Tower Preamplifier	HP	8449B-H02	3008A00372	CAL 11/30/07	11/30/09
Frequency Counter	HP	5385A	2730A03025	CAL 7/6/07	7/6/09
Hygro-Thermometer	Extech	445703	0602	CAL 11/15/07	11/15/09
Antenna: Log-Periodic	Electro-Metrics	LPA-30	409	CAL 7/18/08	7/18/09
Measuring Tape-7.5M	Kraftixx	7.5M PROFI		CHAR 11/13/07	11/13/09
Digital Multimeter	Fluke	FLUKE-77-3	79510408	CAL 3/23/09	4/23/11
System One	Audio Precision	System One	SYS1-45868	CHAR 2/27/08	2/27/10
Temperature Chamber	Tenney Engineering	TTRC	11717-7	CHAR 4/25/08	4/25/10

APPLICANT: NORTHFIELD TELECOMMUNICATIONS, INC. d/b/a ADVANCED WIRELESS COMMUNICATONS
 FCC ID: Q9SAWR391V2
 IC: 4651A-AWR391V2
 MODEL: AWR391V2
 REPORT: Y:\N\NORTHFIELD_Q9S\644AUT9\644AUT9TestReport.doc