

## DECLARATION OF COMPLIANCE SAR RF EXPOSURE EVALUATION

<p><b><u>Test Lab</u></b></p> <p><b>CELLTECH LABS INC.</b> Testing and Engineering Services 1955 Moss Court Kelowna, B.C. Canada V1Y 9L3 Phone: 250-448-7047 Fax: 250-448-7046 e-mail: info@celltechlabs.com web site: www.celltechlabs.com</p>	<p><b><u>Applicant Information</u></b></p> <p><b>Northfield Telecommunications, Inc.</b> <b>d/b/a Advanced Wireless Communications</b> 20809 Kensington Blvd. Lakeville, MN 55044</p>		
<table style="width: 100%; border: none;"> <tr> <td style="width: 40%; vertical-align: top; padding: 5px;"> <p><b>Rule Part(s):</b> <b>Test Procedure(s):</b> <b>Device Classification:</b> <b>Device Type:</b> <b>FCC IDENTIFIER:</b> <b>IC IDENTIFIER:</b> <b>Model(s):</b> <b>Modulation:</b> <b>Tx Frequency Range:</b> <b>Max. RF Output Power Tested:</b> <b>Antenna Type(s) Tested:</b> <b>Battery Type(s) Tested:</b> <b>Body-Worn Accessories Tested:</b></p> <p><b>Max. SAR Levels Evaluated:</b></p> </td> <td style="width: 60%; vertical-align: top; padding: 5px;"> <p>FCC 47 CFR §2.1093; IC RSS-102 Issue 1 (Provisional) FCC OET Bulletin 65, Supplement C (Edition 01-01) Licensed Non-Broadcast Transmitter Held to Face (TNF) Portable FM VHF PTT Radio Transceiver Q9S02042108V 4651A-AWR2108V AWR2108V FM (VHF) 150 - 174 MHz 4.95 Watts Conducted (160.15 MHz) Stubby Lithium-ion 7.2 V, 1250 mAh (P/N: AWB2108) Plastic Belt-Clip Speaker-Microphone (P/N: 420855202945) Ear-Bud Microphone (P/N: 420855203041) Ear-Loop Microphone (P/N: 420855203065) Face-held: 0.324 W/kg (50% Duty Cycle) Body-Worn: 1.71 W/kg (50% Duty Cycle)</p> </td> </tr> </table>		<p><b>Rule Part(s):</b> <b>Test Procedure(s):</b> <b>Device Classification:</b> <b>Device Type:</b> <b>FCC IDENTIFIER:</b> <b>IC IDENTIFIER:</b> <b>Model(s):</b> <b>Modulation:</b> <b>Tx Frequency Range:</b> <b>Max. RF Output Power Tested:</b> <b>Antenna Type(s) Tested:</b> <b>Battery Type(s) Tested:</b> <b>Body-Worn Accessories Tested:</b></p> <p><b>Max. SAR Levels Evaluated:</b></p>	<p>FCC 47 CFR §2.1093; IC RSS-102 Issue 1 (Provisional) FCC OET Bulletin 65, Supplement C (Edition 01-01) Licensed Non-Broadcast Transmitter Held to Face (TNF) Portable FM VHF PTT Radio Transceiver Q9S02042108V 4651A-AWR2108V AWR2108V FM (VHF) 150 - 174 MHz 4.95 Watts Conducted (160.15 MHz) Stubby Lithium-ion 7.2 V, 1250 mAh (P/N: AWB2108) Plastic Belt-Clip Speaker-Microphone (P/N: 420855202945) Ear-Bud Microphone (P/N: 420855203041) Ear-Loop Microphone (P/N: 420855203065) Face-held: 0.324 W/kg (50% Duty Cycle) Body-Worn: 1.71 W/kg (50% Duty Cycle)</p>
<p><b>Rule Part(s):</b> <b>Test Procedure(s):</b> <b>Device Classification:</b> <b>Device Type:</b> <b>FCC IDENTIFIER:</b> <b>IC IDENTIFIER:</b> <b>Model(s):</b> <b>Modulation:</b> <b>Tx Frequency Range:</b> <b>Max. RF Output Power Tested:</b> <b>Antenna Type(s) Tested:</b> <b>Battery Type(s) Tested:</b> <b>Body-Worn Accessories Tested:</b></p> <p><b>Max. SAR Levels Evaluated:</b></p>	<p>FCC 47 CFR §2.1093; IC RSS-102 Issue 1 (Provisional) FCC OET Bulletin 65, Supplement C (Edition 01-01) Licensed Non-Broadcast Transmitter Held to Face (TNF) Portable FM VHF PTT Radio Transceiver Q9S02042108V 4651A-AWR2108V AWR2108V FM (VHF) 150 - 174 MHz 4.95 Watts Conducted (160.15 MHz) Stubby Lithium-ion 7.2 V, 1250 mAh (P/N: AWB2108) Plastic Belt-Clip Speaker-Microphone (P/N: 420855202945) Ear-Bud Microphone (P/N: 420855203041) Ear-Loop Microphone (P/N: 420855203065) Face-held: 0.324 W/kg (50% Duty Cycle) Body-Worn: 1.71 W/kg (50% Duty Cycle)</p>		

Celltech Labs Inc. declares under its sole responsibility that this wireless portable device has demonstrated compliance with the Specific Absorption Rate (SAR) RF exposure requirements specified in FCC 47 CFR §2.1093 and Health Canada's Safety Code 6. The device was tested in accordance with the measurement standards and procedures specified in FCC OET Bulletin 65, Supplement C (Edition 01-01) and Industry Canada RSS-102 Issue 1 (Provisional) for the Occupational / Controlled Exposure environment. All measurements were performed in accordance with the SAR system manufacturer recommendations.

I attest to the accuracy of data. All measurements were performed by me or were made under my supervision and are correct to the best of my knowledge and belief. I assume full responsibility for the completeness of these measurements and vouch for the qualifications of all persons taking them.

This test report shall not be reproduced partially, or in full, without the prior written approval of Celltech Labs Inc. The results and statements contained in this report pertain only to the device(s) evaluated.



**Russell W. Pipe**  
Senior Compliance Technologist  
Celltech Labs Inc.



<b>TABLE OF CONTENTS</b>		
<b>1.0</b>	<b>INTRODUCTION.....</b>	<b>3</b>
<b>2.0</b>	<b>DESCRIPTION OF DUT.....</b>	<b>3</b>
<b>3.0</b>	<b>SAR MEASUREMENT SYSTEM.....</b>	<b>4</b>
<b>4.0</b>	<b>MEASUREMENT SUMMARY.....</b>	<b>5</b>
<b>5.0</b>	<b>DETAILS OF SAR EVALUATION.....</b>	<b>6</b>
<b>6.0</b>	<b>EVALUATION PROCEDURES.....</b>	<b>6</b>
<b>7.0</b>	<b>SYSTEM PERFORMANCE CHECK.....</b>	<b>7</b>
<b>8.0</b>	<b>SIMULATED EQUIVALENT TISSUES.....</b>	<b>8</b>
<b>9.0</b>	<b>SAR SAFETY LIMITS.....</b>	<b>8</b>
<b>10.0</b>	<b>ROBOT SYSTEM SPECIFICATIONS.....</b>	<b>9</b>
<b>11.0</b>	<b>PROBE SPECIFICATION.....</b>	<b>10</b>
<b>12.0</b>	<b>PLANAR PHANTOM.....</b>	<b>10</b>
<b>13.0</b>	<b>VALIDATION PHANTOM.....</b>	<b>10</b>
<b>14.0</b>	<b>DEVICE HOLDER.....</b>	<b>10</b>
<b>15.0</b>	<b>TEST EQUIPMENT LIST.....</b>	<b>11</b>
<b>16.0</b>	<b>MEASUREMENT UNCERTAINTIES.....</b>	<b>12-13</b>
<b>17.0</b>	<b>REFERENCES.....</b>	<b>14</b>
	<b>APPENDIX A - SAR MEASUREMENT DATA.....</b>	<b>15</b>
	<b>APPENDIX B - SYSTEM PERFORMANCE CHECK DATA.....</b>	<b>16</b>
	<b>APPENDIX C - SYSTEM VALIDATION PROCEDURES.....</b>	<b>17</b>
	<b>APPENDIX D - PROBE CALIBRATION.....</b>	<b>18</b>
	<b>APPENDIX E - MEASURED FLUID DIELECTRIC PARAMETERS.....</b>	<b>19</b>
	<b>APPENDIX F - SAR TEST SETUP PHOTOGRAPHS.....</b>	<b>20</b>

## 1.0 INTRODUCTION

This measurement report demonstrates compliance of the Advanced Wireless Communications Model: AWR2108V Portable FM VHF PTT Radio Transceiver FCC ID: Q9S02042108V with the SAR (Specific Absorption Rate) RF exposure requirements specified in FCC 47 CFR §2.1093 (see reference [1]) and Health Canada Safety Code 6 (see reference [2]) for the Occupational / Controlled Exposure environment. The test procedures described in FCC OET Bulletin 65, Supplement C (Edition 01-01) (see reference [3]) and IC RSS-102 Issue 1 (Provisional) (see reference [4]), were employed. A description of the product and operating configuration, detailed summary of the test results, methodology and procedures used in the evaluation, equipment used, and the various provisions of the rules are included within this test report.

## 2.0 DESCRIPTION OF DEVICE UNDER TEST (DUT)

<b>FCC Rule Part(s)</b>	FCC 47 CFR §2.1093		
<b>IC Rule Part(s)</b>	RSS-102 Issue 1 (Provisional)		
<b>Test Procedure(s)</b>	FCC OET Bulletin 65, Supplement C (01-01)		
<b>Device Classification</b>	Licensed Non-Broadcast Transmitter Held to Face (TNF)		
<b>Device Type</b>	Portable FM VHF PTT Radio Transceiver		
<b>FCC IDENTIFIER</b>	Q9S02042108V		
<b>IC IDENTIFIER</b>	4651A-AWR2108V		
<b>Model No.(s)</b>	AWR2108V		
<b>Serial No.(s)</b>	04116C0022	Production Unit	
<b>Modulation</b>	FM (VHF)		
<b>Tx Frequency Range</b>	150 - 174 MHz		
<b>Max. RF Output Power Tested</b>	4.95 Watts	Conducted	160.15 MHz
<b>Battery Type(s) Tested</b>	Lithium-ion	7.2 V, 1250 mAh	P/N: AWB2108
<b>Antenna Type(s) Tested</b>	Stubby	Length: 84 mm	
<b>Body-worn Accessories Tested</b>	Plastic Belt-Clip		
	Speaker-Microphone (P/N: 420855202945)		
	Ear-Bud Microphone (P/N: 420855203041)		
	Ear-Loop Microphone (P/N: 420855203065)		

### 3.0 SAR MEASUREMENT SYSTEM

Celltech Labs Inc. SAR measurement facility utilizes the Dosimetric Assessment System (DASY™) manufactured by Schmid & Partner Engineering AG (SPEAG™) of Zurich, Switzerland. The DASY4 measurement system is comprised of the measurement server, robot controller, computer, near-field probe, probe alignment sensor, specific anthropomorphic mannequin (SAM) phantom, and various planar phantoms for brain and/or body SAR evaluations. The robot is a six-axis industrial robot performing precise movements to position the probe to the location (points) of maximum electromagnetic field (EMF). A cell controller system contains the power supply, robot controller, teach pendant (Joystick), and remote control, is used to drive the robot motors. The Staubli robot is connected to the cell controller to allow software manipulation of the robot. A data acquisition electronic (DAE) circuit performs the signal amplification, signal multiplexing, AD-conversion, offset measurements, mechanical surface detection, collision detection, etc. is connected to the Electro-optical coupler (EOC). The EOC performs the conversion from the optical into digital electric signal of the DAE and transfers data to the DASY4 measurement server. The DAE4 utilizes a highly sensitive electrometer-grade preamplifier with auto-zeroing, a channel and gain-switching multiplexer, a fast 16-bit AD-converter and a command decoder and control logic unit. Transmission to the DASY4 measurement server is accomplished through an optical downlink for data and status information and an optical uplink for commands and clock lines. The mechanical probe-mounting device includes two different sensor systems for frontal and sidewise probe contacts. The sensor systems are also used for mechanical surface detection and probe collision detection. The robot uses its own controller with a built in VME-bus computer.



DASY4 SAR Measurement System with validation phantom



DASY4 SAR Measurement System with Plexiglas planar phantom

## 4.0 MEASUREMENT SUMMARY

### SAR EVALUATION RESULTS

Test Type	Freq. (MHz)	Channel	Test Mode	Conducted Power Before Test (Watts)	Battery Type	Body-Worn Accessories	Separation Distance to Planar Phantom (cm)	Measured SAR 1g (W/kg)		SAR Drift During Test (dB)	Scaled SAR 1g (W/kg) with drift (to 5 Watts)					
								Duty Cycle			Duty Cycle					
								100%	50%	100%	50%					
Face	160.15	Mid	CW	4.95	Li-ion	-	2.5	0.508	0.254	-1.01	0.647	0.324				
Body	160.15	Mid	CW	4.95	Li-ion	Belt-Clip Speaker-Mic	1.3	P	3.39	P	1.70	0.107	P	3.42	P	1.71
				4.87				S	1.92	S	0.960	-0.205	S	2.03	S	1.02
Body	160.15	Mid	CW	4.95	Li-ion	Belt-Clip Ear-Bud Mic	1.3	0.855	0.428	-0.356	0.937	0.469				
Body	160.15	Mid	CW	4.95	Li-ion	Belt-Clip Ear-Loop Mic	1.3	P	0.584	P	0.292	-0.654	P	0.685	P	0.343
				4.90				S	0.566	S	0.283	-1.06	S	0.729	S	0.365

**ANSI / IEEE C95.1 1992 - SAFETY LIMIT**  
**BRAIN / BODY: 8.0 W/kg (averaged over 1 gram)**  
**Spatial Peak - Occupational / Controlled Exposure**

Dielectric Constant $\epsilon_r$	150 MHz Brain		150 MHz Body		Ambient Temperature	Brain	24.8 °C	Body	25.2 °C
	IEEE Target	Measured	IEEE Target	Measured	Fluid Temperature	Brain	22.1 °C	Body	23.1 °C
	52.3 ( $\pm 5\%$ )	53.2	61.9 ( $\pm 5\%$ )	60.3	Atmospheric Pressure	Brain	107.7 kPa	Body	106.9 kPa
Conductivity $\sigma$ (mho/m)	150 MHz Brain		150 MHz Body		Relative Humidity	Brain	30%	Body	30%
	IEEE Target	Measured	IEEE Target	Measured	Fluid Depth	Brain	$\geq 15$ cm	Body	$\geq 15$ cm
	0.76 ( $\pm 5\%$ )	0.73	0.80 ( $\pm 5\%$ )	0.78	$\rho$ (Kg/m <sup>3</sup> )	Brain	1000	Body	1000

**Notes:**

- The measurement results were obtained with the DUT tested in the conditions described in this report. Detailed measurement data and plots showing the maximum SAR location of the DUT are reported in Appendix A.
- The SAR levels measured at the mid channel were  $\geq 3$  dB below the SAR limit, therefore SAR evaluation for the low and high channels was optional (per FCC OET Bulletin 65, Supplement C, Edition 01-01 (see reference [3])).
- Secondary peak SAR locations were evaluated to report SAR levels within 2 dB of the primary (P = Primary, S = Secondary).
- The power drifts measured by the DASY4 system for the duration of the SAR evaluations were added to the measured SAR levels to report scaled SAR results as shown in the above table.
- A SAR-versus-Time power drift evaluation was performed in the test configuration that reported the maximum SAR drift. See Appendix A (SAR Test Plots) for SAR-versus-Time power drift evaluation plot.
- The ambient and fluid temperatures were measured prior to, and during, the fluid dielectric parameter check and the SAR evaluation. The temperatures reported were consistent for all measurement periods.
- The dielectric parameters of the simulated tissue mixtures were measured prior to the evaluation using an HP 85070C Dielectric Probe Kit and an HP 8753E Network Analyzer (see Appendix E for printout of measured fluid dielectric parameters).
- The SAR evaluations were performed within 24 hours of the system performance check.



## 5.0 DETAILS OF SAR EVALUATION

The Advanced Wireless Communications Model: AWR2108V Portable FM VHF PTT Radio Transceiver FCC ID: Q9S02042108V was compliant for localized Specific Absorption Rate (Occupational / Controlled Exposure) based on the test provisions and conditions described below. The detailed test setup photographs are shown in Appendix F.

1. The DUT was evaluated in a face-held configuration with the front of the radio placed parallel to the outer surface of the planar phantom. A 2.5 cm separation distance was maintained between the front side of the DUT and the outer surface of the planar phantom for the duration of the test.
2. The DUT was evaluated in a body-worn configuration with the back of the radio placed parallel to the outer surface of the planar phantom. The attached plastic belt-clip was touching the planar phantom and provided a 1.3 cm separation distance between the back of the DUT and the outer surface of the planar phantom. The DUT was tested for body-worn SAR with the speaker-microphone, ear-bud microphone, and ear-loop microphone accessories.
3. The conducted power levels were measured before each test using a Gigatronics 8652A Universal Power Meter according to the procedures described in FCC 47 CFR §2.1046.
4. The power drifts measured by the DASY4 system during the SAR evaluations were added to the measured SAR levels to report scaled SAR results (see test data table - page 5).
5. A SAR-versus-Time power drift evaluation was performed in the test configuration that reported the maximum SAR drift. See Appendix A (SAR Test Plots) for SAR-versus-Time power drift evaluation plot.
6. The area scan evaluation was performed with a fully charged battery. After the area scan was completed the radio was cooled down to room temperature and the battery was replaced with a fully charged battery prior to the zoom scan evaluation.
7. The DUT was tested in unmodulated continuous transmit operation (Continuous Wave mode at 100% duty cycle) with the transmit key constantly depressed. For a push-to-talk device the 50% duty cycle compensation reported assumes a transmit/receive cycle of equal time base.
8. The SAR evaluations were performed using a Plexiglas planar phantom.
9. A stack of low-density, low-loss dielectric foamed polystyrene was used in place of the device holder.

## 6.0 EVALUATION PROCEDURES

- a. (i) The evaluation was performed in the applicable area of the phantom depending on the type of device being tested. For devices held to the ear during normal operation, both the left and right ear positions were evaluated using the SAM phantom.  
(ii) For body-worn and face-held devices a planar phantom was used.
- b. The SAR was determined by a pre-defined procedure within the DASY4 software. Upon completion of a reference and optical surface check, the exposed region of the phantom was scanned near the inner surface with a grid spacing of 15mm x 15mm.

An area scan was determined as follows:

- c. Based on the defined area scan grid, a more detailed grid is created to increase the points by a factor of 10. The interpolation function then evaluates all field values between corresponding measurement points.
- d. A linear search is applied to find all the candidate maxima. Subsequently, all maxima are removed that are >2 dB from the global maximum. The remaining maxima are then used to position the cube scans.

A 1g and 10g spatial peak SAR was determined as follows:

- e. Extrapolation is used to find the points between the dipole center of the probe and the surface of the phantom. This data cannot be measured, since the center of the dipoles is 2.7 mm away from the tip of the probe and the distance between the surface and the lowest measuring point is 1.4 mm (see probe calibration document in Appendix D). The extrapolation was based on trivariate quadratics computed from the previously calculated 3D interpolated points nearest the phantom surface.
- f. Interpolated data is used to calculate the average SAR over 1g and 10g cubes by spatially discretizing the entire measured cube. The volume used to determine the averaged SAR is a 1mm grid (42875 interpolated points).
- g. A zoom scan volume of 32 mm x 32 mm x 30 mm (5 x 5 x 7 points) centered at the peak SAR location determined from the area scan is used for all zoom scans for devices with a transmit frequency < 800 MHz. Zoom scans for frequencies ≥ 800 MHz are determined with a scan volume of 30 mm x 30 mm x 30 mm (7 x 7 x 7) to ensure complete capture of the peak spatial-average SAR.

## 7.0 SYSTEM PERFORMANCE CHECK

Prior to the SAR evaluation a system check was performed using a Plexiglas planar phantom with a 300MHz dipole (see Appendix C for system validation procedure). The dielectric parameters of the simulated brain tissue mixture were measured prior to the system performance check using an HP 85070C Dielectric Probe Kit and an HP 8753E Network Analyzer (see Appendix E for printout of measured fluid dielectric parameters). A forward power of 250mW was applied to the dipole and the system was verified to a tolerance of  $\pm 10\%$  (see Appendix B for system performance check test plot).

SYSTEM PERFORMANCE CHECK													
Test Date	Equiv. Tissue	SAR 1g (W/kg)		Dielectric Constant $\epsilon_r$		Conductivity $\sigma$ (mho/m)		$\rho$ (Kg/m <sup>3</sup> )	Amb. Temp. (°C)	Fluid Temp. (°C)	Fluid Depth (cm)	Humid. (%)	Barom. Press. (kPa)
		IEEE Target	Measured	IEEE Target	Measured	IEEE Target	Measured						
02/25/04	Brain	0.750 $\pm 10\%$	0.772 (+2.9%)	45.3 $\pm 5\%$	45.6	0.87 $\pm 5\%$	0.89	1000	25.1	22.3	$\geq 15$	30	107.3

Note(s):

- The ambient and fluid temperatures were measured prior to, and during, the fluid dielectric parameter check and the system performance check. The temperatures listed in the table above were consistent for all measurement periods.

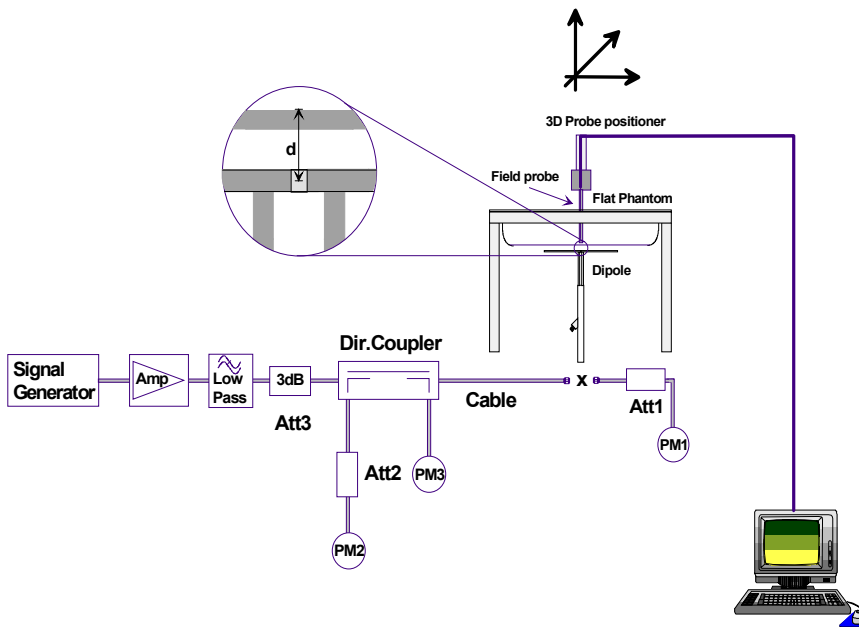

Figure 1. System Performance Check Setup Diagram



300 MHz Dipole Setup

## 8.0 SIMULATED EQUIVALENT TISSUES

The simulated tissue mixtures consist of a viscous gel using hydroxyethylcellulose (HEC) gelling agent and saline solution. Preservation with a bactericide is added and visual inspection is made to ensure air bubbles are not trapped during the mixing process. The fluid was prepared according to standardized procedures and measured for dielectric parameters (permittivity and conductivity).

SIMULATED TISSUE MIXTURES			
INGREDIENT	300 MHz Brain (%) (System Check)	150 MHz Brain (%) (DUT Evaluation)	150 MHz Body (%) (DUT Evaluation)
Water	37.56	38.35	46.6
Sugar	55.32	55.5	49.7
Salt	5.95	5.15	2.6
HEC	0.98	0.9	1.0
Bactericide	0.19	0.1	0.1

## 9.0 SAR SAFETY LIMITS

EXPOSURE LIMITS	SAR (W/kg)	
	(General Population / Uncontrolled Exposure Environment)	(Occupational / Controlled Exposure Environment)
Spatial Average (averaged over the whole body)	0.08	0.4
Spatial Peak (averaged over any 1g of tissue)	1.60	8.0
Spatial Peak (hands/wrists/feet/ankles averaged over 10g)	4.0	20.0

Notes:

1. Uncontrolled environments are defined as locations where there is potential exposure of individuals who have no knowledge or control of their potential exposure.
2. Controlled environments are defined as locations where there is potential exposure of individuals who have knowledge of their potential exposure and can exercise control over their exposure.



## 10.0 ROBOT SYSTEM SPECIFICATIONS

### Specifications

**POSITIONER:** Stäubli Unimation Corp. Robot Model: RX60L  
**Repeatability:** 0.02 mm  
**No. of axis:** 6

### Data Acquisition Electronic (DAE) System

#### Cell Controller

**Processor:** AMD Athlon XP 2400+  
**Clock Speed:** 2.0 GHz  
**Operating System:** Windows XP Professional

#### Data Converter

**Features:** Signal Amplifier, multiplexer, A/D converter, and control logic  
**Software:** DASY4 software  
**Connecting Lines:** Optical downlink for data and status info.  
 Optical uplink for commands and clock

### DASY4 Measurement Server

**Function:** Real-time data evaluation for field measurements and surface detection  
**Hardware:** PC/104 166MHz Pentium CPU; 32 MB chipdisk; 64 MB RAM  
**Connections:** COM1, COM2, DAE, Robot, Ethernet, Service Interface

### E-Field Probe

**Model:** ET3DV6  
**Serial No.:** 1590  
**Construction:** Triangular core fiber optic detection system  
**Frequency:** 10 MHz to 6 GHz  
**Linearity:** ±0.2 dB (30 MHz to 3 GHz)

### Evaluation Phantom

**Type:** Planar Phantom  
**Shell Material:** Plexiglas  
**Bottom Thickness:** 2.0 mm ± 0.1 mm  
**Outer Dimensions:** 75.0 cm (L) x 22.5 cm (W) x 20.5 cm (H); Back Plane: 25.7 cm (H)

### Validation Phantom (≤ 450MHz)

**Type:** Planar Phantom  
**Shell Material:** Plexiglas  
**Bottom Thickness:** 6.2 mm ± 0.1 mm  
**Outer Dimensions:** 86.0 cm (L) x 39.5 cm (W) x 21.8 cm (H)

## 11.0 PROBE SPECIFICATION (ET3DV6)

Construction:	Symmetrical design with triangular core Built-in shielding against static charges PEEK enclosure material (resistant to organic solvents, e.g. glycol)
Calibration:	In air from 10 MHz to 2.5 GHz In brain simulating tissue at frequencies of 900 MHz and 1.8 GHz (accuracy $\pm 8\%$ )
Frequency:	10 MHz to > 6 GHz; Linearity: $\pm 0.2$ dB (30 MHz to 3 GHz)
Directivity:	$\pm 0.2$ dB in brain tissue (rotation around probe axis) $\pm 0.4$ dB in brain tissue (rotation normal to probe axis)
Dynamic Range:	5 $\mu$ W/g to > 100 mW/g; Linearity: $\pm 0.2$ dB
Surface Detection:	$\pm 0.2$ mm repeatability in air and clear liquids over diffuse reflecting surfaces
Dimensions:	Overall length: 330 mm Tip length: 16 mm Body diameter: 12 mm Tip diameter: 6.8 mm Distance from probe tip to dipole centers: 2.7 mm
Application:	General dosimetry up to 3 GHz Compliance tests of mobile phone



ET3DV6 E-Field Probe

## 12.0 PLANAR PHANTOM

The planar phantom is constructed of Plexiglas material with a 2.0 mm shell thickness for face-held and body-worn SAR evaluations of handheld radio transceivers. The planar phantom is mounted on the side of the DASY4 compact system table.

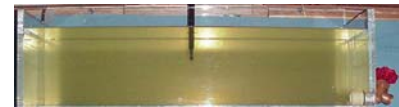

Plexiglas Planar Phantom

## 13.0 VALIDATION PLANAR PHANTOM

The validation planar phantom is constructed of Plexiglas material with a 6.0 mm shell thickness for SAR system validations at 450MHz and below. The validation planar phantom is mounted in the DASY4 compact system table.



Validation Planar Phantom

## 14.0 DEVICE HOLDER

The DASY4 device holder has two scales for device rotation (with respect to the body axis) and the device inclination (with respect to the line between the ear openings). The plane between the ear openings and the mouth tip has a rotation angle of 65°. The bottom plate contains three pair of bolts for locking the device holder. The device holder positions are adjusted to the standard measurement positions in the three sections.



Device Holder

## 15.0 TEST EQUIPMENT LIST

TEST EQUIPMENT	SERIAL NO.	CALIBRATION DATE
Schmid & Partner DASY4 System	-	-
DASY4 Measurement Server	1078	N/A
-Robot	599396-01	N/A
-ET3DV6 E-Field Probe	1590	May 2003
-300MHz Validation Dipole	135	Oct 2003
-450MHz Validation Dipole	136	Nov 2003
-900MHz Validation Dipole	054	June 2003
-1800MHz Validation Dipole	247	June 2003
-2450MHz Validation Dipole	150	Sept 2003
-Plexiglas Planar Phantom	161	N/A
-Validation Planar Phantom	137	N/A
HP 85070C Dielectric Probe Kit	N/A	N/A
Gigatronics 8651A Power Meter	8650137	April 2003
Gigatronics 8652A Power Meter	1835267	April 2003
Gigatronics 80701A Power Sensor	1833542	April 2003
Gigatronics 80701A Power Sensor	1834350	April 2003
HP E4408B Spectrum Analyzer	US39240170	Dec 2003
HP 8594E Spectrum Analyzer	3543A02721	April 2003
HP 8753E Network Analyzer	US38433013	May 2003
HP 8648D Signal Generator	3847A00611	May 2003
Amplifier Research 5S1G4 Power Amplifier	26235	N/A

## 16.0 MEASUREMENT UNCERTAINTIES

UNCERTAINTY BUDGET FOR DEVICE EVALUATION						
Error Description	Uncertainty Value ±%	Probability Distribution	Divisor	$C_i$ 1g	Standard Uncertainty ±% (1g)	$v_i$ or $v_{eff}$
<b>Measurement System</b>						
Probe calibration	± 4.0	Normal	1	1	± 4.0	∞
Axial isotropy of the probe	± 4.7	Rectangular	√3	(1- $c_p$ )	± 1.9	∞
Spherical isotropy of the probe	± 9.6	Rectangular	√3	( $c_p$ )	± 3.9	∞
Spatial resolution	± 0.0	Rectangular	√3	1	± 0.0	∞
Boundary effects	± 5.5	Rectangular	√3	1	± 3.2	∞
Probe linearity	± 4.7	Rectangular	√3	1	± 2.7	∞
Detection limit	± 1.0	Rectangular	√3	1	± 0.6	∞
Readout electronics	± 1.0	Normal	1	1	± 1.0	∞
Response time	± 0.8	Rectangular	√3	1	± 0.5	∞
Integration time	± 1.4	Rectangular	√3	1	± 0.8	∞
RF ambient conditions	± 3.0	Rectangular	√3	1	± 1.7	∞
Mech. constraints of robot	± 0.4	Rectangular	√3	1	± 0.2	∞
Probe positioning	± 2.9	Rectangular	√3	1	± 1.7	∞
Extrapolation & integration	± 3.9	Rectangular	√3	1	± 2.3	∞
<b>Test Sample Related</b>						
Device positioning	± 6.0	Normal	√3	1	± 6.7	12
Device holder uncertainty	± 5.0	Normal	√3	1	± 5.9	8
Power drift	± 5.0	Rectangular	√3		± 2.9	∞
<b>Phantom and Setup</b>						
Phantom uncertainty	± 4.0	Rectangular	√3	1	± 2.3	∞
Liquid conductivity (target)	± 5.0	Rectangular	√3	0.6	± 1.7	∞
Liquid conductivity (measured)	± 5.0	Rectangular	√3	0.6	± 1.7	∞
Liquid permittivity (target)	± 5.0	Rectangular	√3	0.6	± 1.7	∞
Liquid permittivity (measured)	± 5.0	Rectangular	√3	0.6	± 1.7	∞
<b>Combined Standard Uncertainty</b>					<b>± 13.03</b>	
<b>Expanded Uncertainty (k=2)</b>					<b>± 26.07</b>	

Measurement Uncertainty Table in accordance with IEEE Standard 1528-2003 (see reference [5])

## MEASUREMENT UNCERTAINTIES (Cont.)

UNCERTAINTY BUDGET FOR SYSTEM VALIDATION						
Error Description	Uncertainty Value ±%	Probability Distribution	Divisor	$C_i$ 1g	Standard Uncertainty ±% (1g)	$v_i$ or $v_{eff}$
<b>Measurement System</b>						
Probe calibration	± 4.0	Normal	1	1	± 4.0	∞
Axial isotropy of the probe	± 4.7	Rectangular	√3	(1- $c_p$ )	± 1.9	∞
Spherical isotropy of the probe	± 9.6	Rectangular	√3	( $c_p$ )	± 3.9	∞
Spatial resolution	± 0.0	Rectangular	√3	1	± 0.0	∞
Boundary effects	± 5.5	Rectangular	√3	1	± 3.2	∞
Probe linearity	± 4.7	Rectangular	√3	1	± 2.7	∞
Detection limit	± 1.0	Rectangular	√3	1	± 0.6	∞
Readout electronics	± 1.0	Normal	1	1	± 1.0	∞
Response time	± 0.8	Rectangular	√3	1	± 0.5	∞
Integration time	± 1.4	Rectangular	√3	1	± 0.8	∞
RF ambient conditions	± 3.0	Rectangular	√3	1	± 1.7	∞
Mech. constraints of robot	± 0.4	Rectangular	√3	1	± 0.2	∞
Probe positioning	± 2.9	Rectangular	√3	1	± 1.7	∞
Extrapolation & integration	± 3.9	Rectangular	√3	1	± 2.3	∞
<b>Dipole</b>						
Dipole Axis to Liquid Distance	± 2.0	Rectangular	√3	1	± 1.2	∞
Input Power	± 4.7	Rectangular	√3	1	± 2.7	∞
<b>Phantom and Setup</b>						
Phantom uncertainty	± 4.0	Rectangular	√3	1	± 2.3	∞
Liquid conductivity (target)	± 5.0	Rectangular	√3	0.6	± 1.7	∞
Liquid conductivity (measured)	± 5.0	Rectangular	√3	0.6	± 1.7	∞
Liquid permittivity (target)	± 5.0	Rectangular	√3	0.6	± 1.7	∞
Liquid permittivity (measured)	± 5.0	Rectangular	√3	0.6	± 1.7	∞
<b>Combined Standard Uncertainty</b>					<b>± 9.58</b>	
<b>Expanded Uncertainty (k=2)</b>					<b>± 19.16</b>	

Measurement Uncertainty Table in accordance with IEEE Standard 1528-2003 (see reference [5])



Test Report S/N:	021804-480Q9S
Test Date(s):	February 25, 2004
Test Type:	FCC/IC SAR Evaluation

## 17.0 REFERENCES

- [1] Federal Communications Commission, "Radiofrequency radiation exposure evaluation: portable devices", Rule Part 47 CFR §2.1093: 1999.
- [2] Health Canada, "Limits of Human Exposure to Radiofrequency Electromagnetic Fields in the Frequency Range from 3 kHz to 300 GHz", Safety Code 6.
- [3] Federal Communications Commission, "Evaluating Compliance with FCC Guidelines for Human Exposure to Radio frequency Electromagnetic Fields", OET Bulletin 65, Supplement C (Edition 01-01), FCC, Washington, D.C.: June 2001.
- [4] Industry Canada, "Evaluation Procedure for Mobile and Portable Radio Transmitters with respect to Health Canada's Safety Code 6 for Exposure of Humans to Radio Frequency Fields", Radio Standards Specification RSS-102 Issue 1 (Provisional): September 1999.
- [5] IEEE Std 1528-2003, "Recommended Practice for Determining the Peak Spatial-Average Specific Absorption Rate (SAR) in the Human Head from Wireless Communications Devices: Measurement Techniques".

Test Report S/N:	021804-480Q9S
Test Date(s):	February 25, 2004
Test Type:	FCC/IC SAR Evaluation

## APPENDIX A - SAR MEASUREMENT DATA

## Face-Held SAR

Dated Tested: 02/25/04

DUT: Advanced Wireless Model: AWR2108V; Type: Portable FM VHF PTT Radio Transceiver; Serial: 04116C0022

Ambient Temp: 24.8 °C; Fluid Temp: 22.1 °C; Barometric Pressure: 107.7 kPa; Humidity: 30%

Communication System: FM VHF

Frequency: 160.15 MHz; Duty Cycle: 1:1

7.2V Li-ion Battery Pack (P/N: AWB2108)

RF Output Power: 4.95 Watts (Conducted)

Medium: HSL150 ( $\sigma = 0.73$  mho/m;  $\epsilon_r = 53.2$ ;  $\rho = 1000$  kg/m<sup>3</sup>)

- Probe: ET3DV6 - SN1590; ConvF(9.6, 9.6, 9.6); Calibrated: 15/05/2003
- Sensor-Surface: 4mm (Mechanical Surface Detection)
- Electronics: DAE3 Sn353; Calibrated: 19/12/2003
- Phantom: Planar; Type: Plexiglas; Serial: 161
- Measurement SW: DASy4, V4.2 Build 12; Postprocessing SW: SEMCAD, V1.8 Build 94

### Face-Held - 2.5 cm Separation Distance - Mid Channel/Area Scan (7x14x1):

Measurement grid: dx=15mm, dy=15mm

### Face-Held - 2.5 cm Separation Distance - Mid Channel/Zoom Scan (5x5x7)/Cube 0:

Measurement grid: dx=8mm, dy=8mm, dz=5mm

Peak SAR (extrapolated) = 1.01 W/kg

**SAR(1 g) = 0.508 mW/g; SAR(10 g) = 0.360 mW/g**

Reference Value = 28 V/m

Power Drift = -1.01 dB

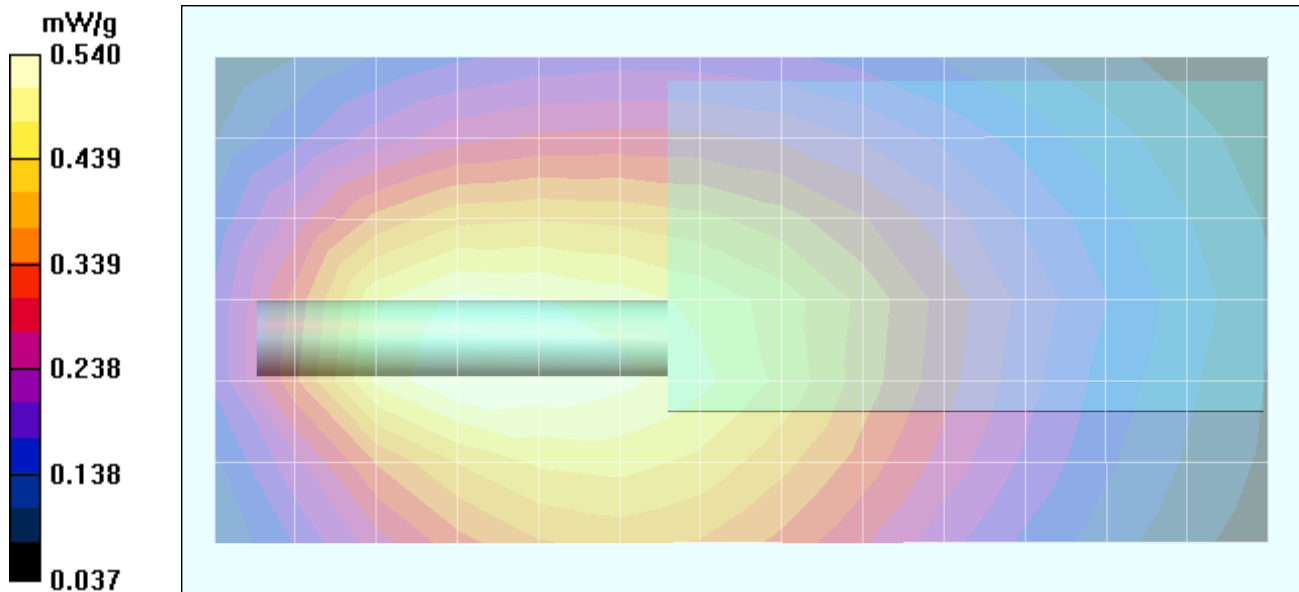

### Z-Axis Scan

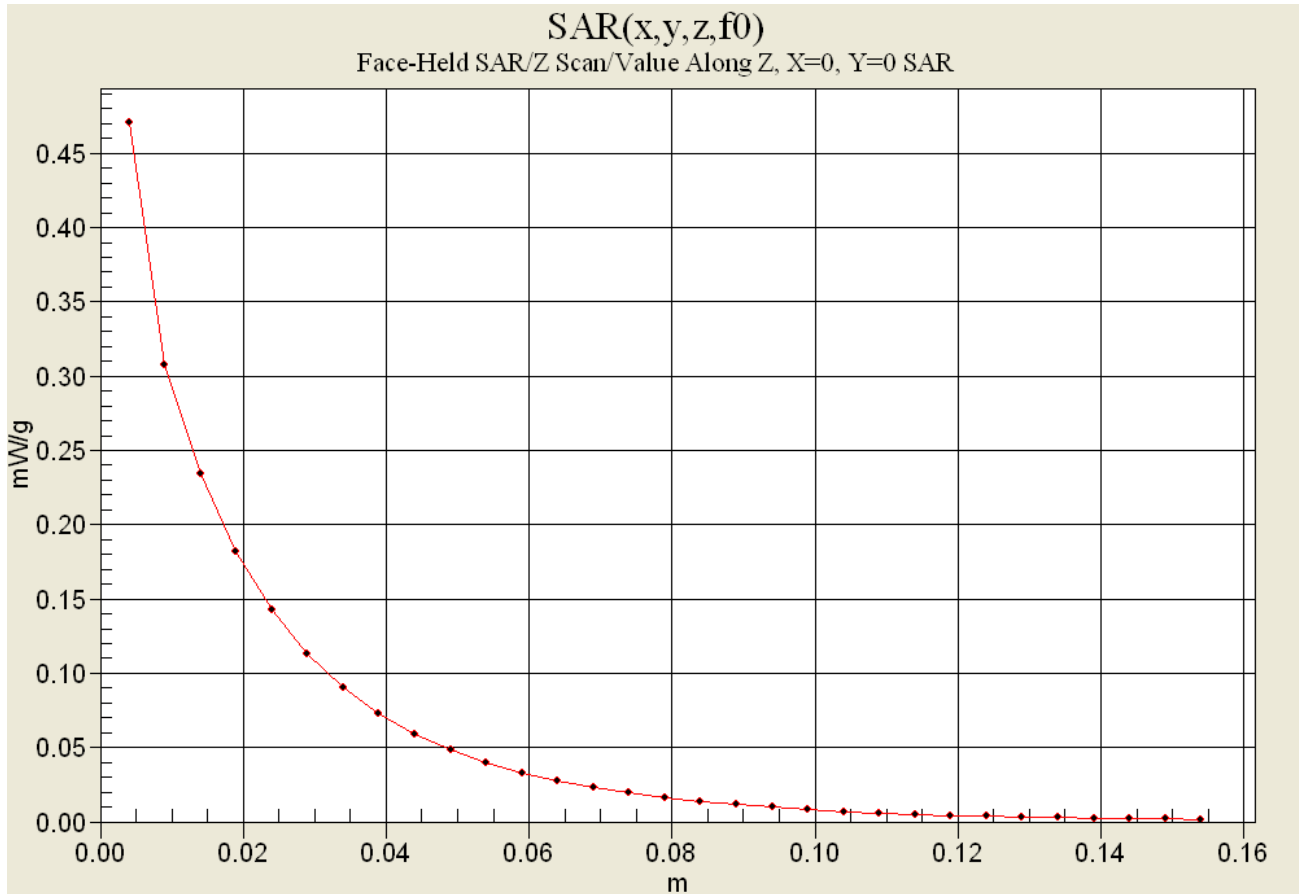

## Body-Worn SAR

Date Tested: 02/25/04

DUT: Advanced Wireless Model: AWR2108V; Type: Portable FM VHF PTT Radio Transceiver; Serial: 04116C0022

Ambient Temp: 25.2 °C; Fluid Temp: 23.1 °C; Barometric Pressure: 106.9 kPa; Humidity: 30%

### Body-Worn Accessories: Plastic Belt-Clip & Speaker-Microphone Accessory (P/N: 420855202945)

Communication System: FM VHF  
 Frequency: 160.15 MHz; Duty Cycle: 1:1  
 7.2V Li-ion Battery Pack (P/N: AWB2108)  
 RF Output Power: 4.95 Watts (Conducted)  
 RF Output Power: 4.87 Watts (Conducted) 2<sup>nd</sup> Maximum  
 Medium: M150 ( $\sigma = 0.78 \text{ mho/m}$ ;  $\epsilon_r = 60.3$ ;  $\rho = 1000 \text{ kg/m}^3$ )

- Probe: ET3DV6 - SN1590; ConvF(9.2, 9.2, 9.2); Calibrated: 15/05/2003
- Sensor-Surface: 4mm (Mechanical Surface Detection)
- Electronics: DAE3 Sn353; Calibrated: 19/12/2003
- Phantom: Planar; Type: Plexiglas; Serial: 161
- Measurement SW: DAS4, V4.2 Build 12; Postprocessing SW: SEMCAD, V1.8 Build 94

### Body-Worn - 1.3 cm Belt-Clip Separation Distance - Mid Channel/Area Scan (7x14x1):

Measurement grid: dx=15mm, dy=15mm

### Body-Worn - 1.3 cm Belt-Clip Separation Distance - Mid Channel/Zoom Scan (5x5x7)/Cube 0:

Measurement grid: dx=8mm, dy=8mm, dz=5mm

Peak SAR (extrapolated) = 9.89 W/kg

**SAR(1 g) = 3.39 mW/g; SAR(10 g) = 1.87 mW/g**

Reference Value = 53.6 V/m

Power Drift = 0.107 dB

### Body-Worn - 1.3 cm Belt-Clip Separation Distance - Mid Channel/Zoom Scan (5x5x7)/Cube 1:

Measurement grid: dx=8mm, dy=8mm, dz=5mm

Peak SAR (extrapolated) = 5.48 W/kg

**SAR(1 g) = 1.92 mW/g; SAR(10 g) = 1.17 mW/g**

Reference Value = 53.6 V/m

Power Drift = -0.205 dB

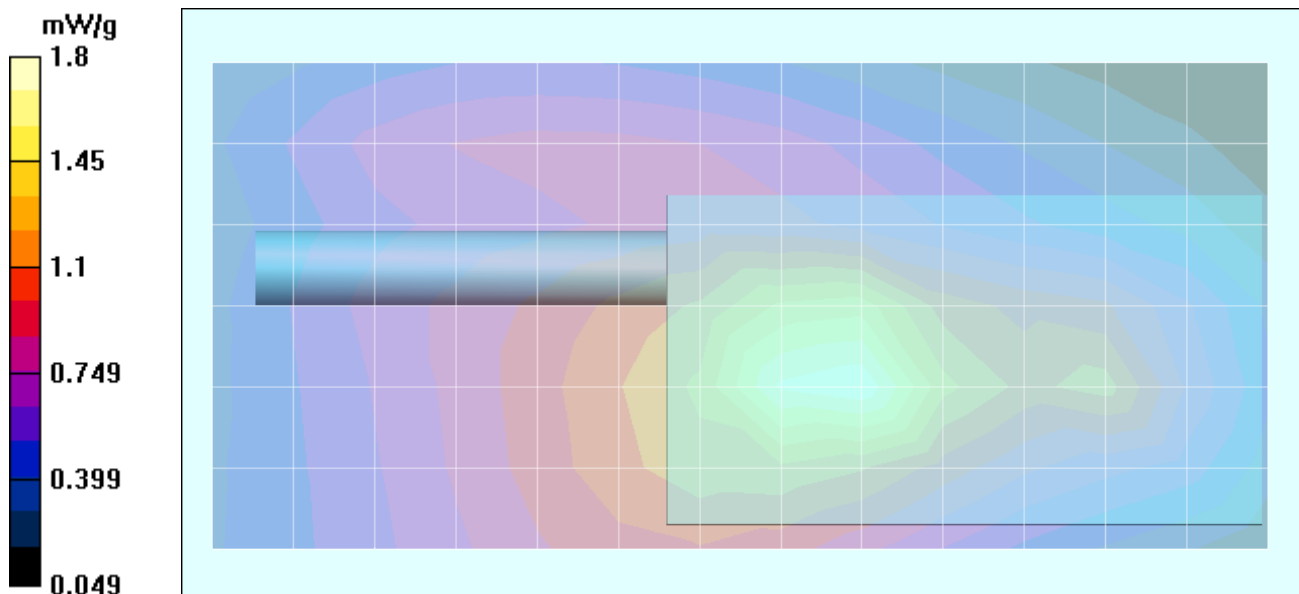



### Z-Axis Scan

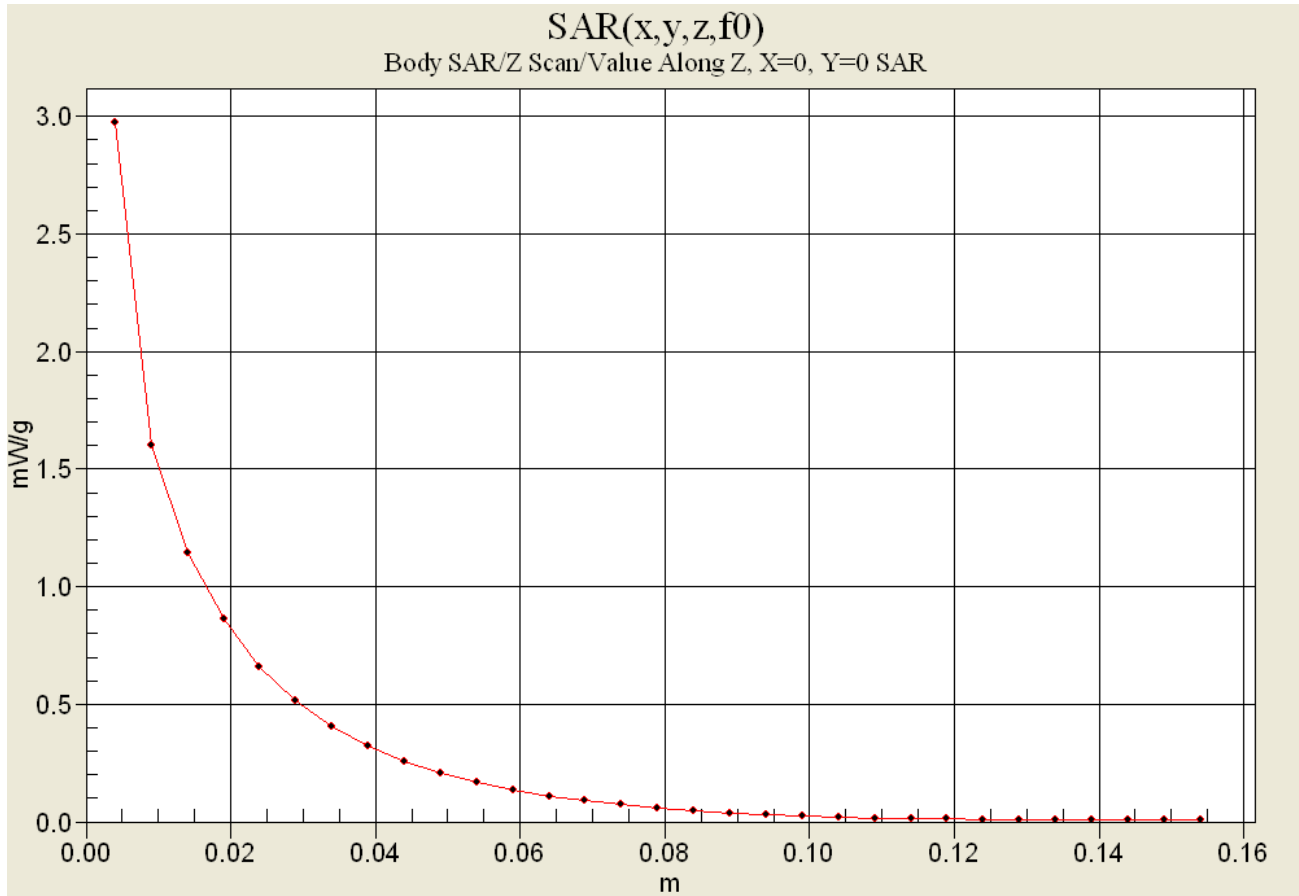

## Body-Worn SAR

Date Tested: 02/25/04

DUT: Advanced Wireless Model: AWR2108V; Type: Portable FM VHF PTT Radio Transceiver; Serial: 04116C0022

Ambient Temp: 25.2 °C; Fluid Temp: 23.1 °C; Barometric Pressure: 106.9 kPa; Humidity: 30%

### Body-Worn Accessories: Plastic Belt-Clip & Ear-Bud Microphone Accessory (P/N: 420855203041)

Communication System: FM VHF  
 Frequency: 160.15 MHz; Duty Cycle: 1:1  
 7.2V Li-ion Battery Pack (P/N: AWB2108)  
 RF Output Power: 4.95 Watts (Conducted)  
 Medium: M150 ( $\sigma = 0.78 \text{ mho/m}$ ;  $\epsilon_r = 60.3$ ;  $\rho = 1000 \text{ kg/m}^3$ )

- Probe: ET3DV6 - SN1590; ConvF(9.2, 9.2, 9.2); Calibrated: 15/05/2003
- Sensor-Surface: 4mm (Mechanical Surface Detection)
- Electronics: DAE3 Sn353; Calibrated: 19/12/2003
- Phantom: Planar; Type: Plexiglas; Serial: 161
- Measurement SW: DASY4, V4.2 Build 12; Postprocessing SW: SEMCAD, V1.8 Build 94

### Body-Worn - 1.3 cm Belt-Clip Separation Distance - Mid Channel/Area Scan (7x14x1):

Measurement grid: dx=15mm, dy=15mm

### Body-Worn - 1.3 cm Belt-Clip Separation Distance - Mid Channel/Zoom Scan (5x5x7)/Cube 0:

Measurement grid: dx=8mm, dy=8mm, dz=5mm  
 Peak SAR (extrapolated) = 2.08 W/kg  
**SAR(1 g) = 0.855 mW/g; SAR(10 g) = 0.516 mW/g**  
 Reference Value = 31.1 V/m  
 Power Drift = -0.356 dB

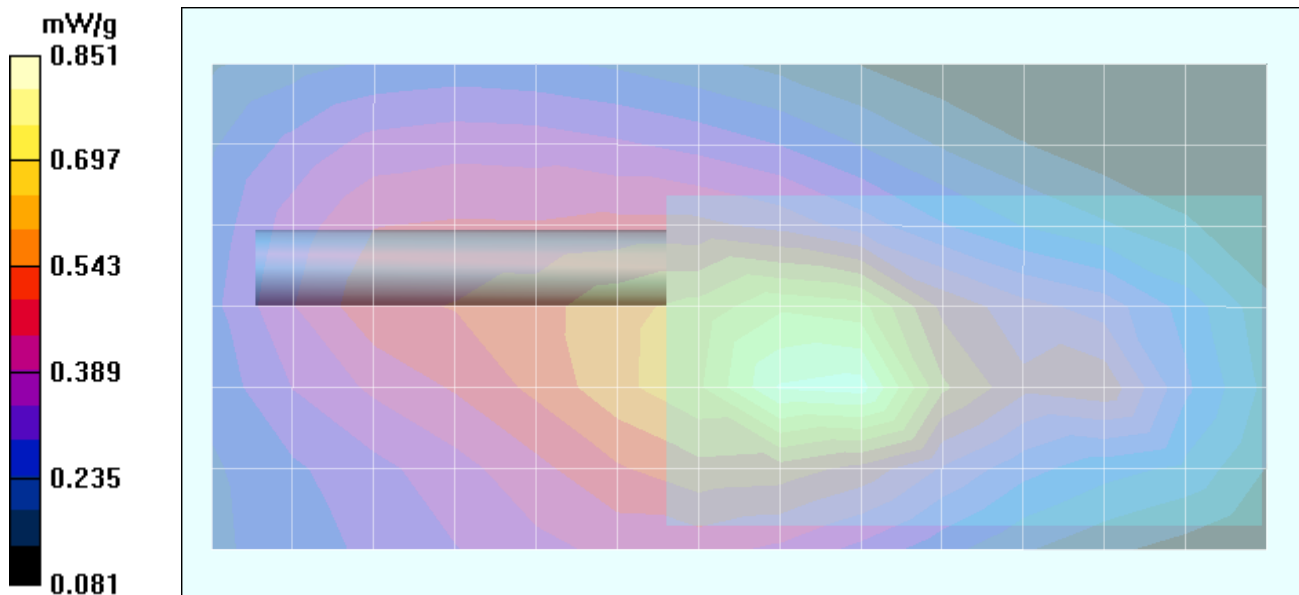

## Body-Worn SAR

Date Tested: 02/25/04

DUT: Advanced Wireless Model: AWR2108V; Type: Portable FM VHF PTT Radio Transceiver; Serial: 04116C0022  
 Ambient Temp: 25.2 °C; Fluid Temp: 23.1 °C; Barometric Pressure: 106.9 kPa; Humidity: 30%

### Body-Worn Accessories: Plastic Belt-Clip & Ear-Loop Microphone Accessory (P/N: 420855203065)

Communication System: FM VHF  
 Frequency: 160.15 MHz; Duty Cycle: 1:1  
 7.2V Li-ion Battery Pack (P/N: AWB2108)  
 RF Output Power: 4.95 Watts (Conducted)  
 RF Output Power: 4.90 Watts (Conducted) 2<sup>nd</sup> Maximum  
 Medium: M150 ( $\sigma = 0.78$  mho/m;  $\epsilon_r = 60.3$ ;  $\rho = 1000$  kg/m<sup>3</sup>)

- Probe: ET3DV6 - SN1590; ConvF(9.2, 9.2, 9.2); Calibrated: 15/05/2003
- Sensor-Surface: 4mm (Mechanical Surface Detection)
- Electronics: DAE3 Sn353; Calibrated: 19/12/2003
- Phantom: Planar; Type: Plexiglas; Serial: 161
- Measurement SW: DASY4, V4.2 Build 44; Postprocessing SW: SEMCAD, V1.8 Build 112

### Body-Worn - 1.3 cm Belt-Clip Separation Distance - Mid Channel/Area Scan (7x14x1):

Measurement grid: dx=15mm, dy=15mm

### Body-Worn - 1.3 cm Belt-Clip Separation Distance - Mid Channel/Zoom Scan (5x5x7)/Cube 0:

Measurement grid: dx=8mm, dy=8mm, dz=5mm  
 Peak SAR (extrapolated) = 1.38 W/kg  
**SAR(1 g) = 0.584 mW/g; SAR(10 g) = 0.370 mW/g**  
 Reference Value = 27.9 V/m;  
 Power Drift = -0.654 dB

### Body-Worn - 1.3 cm Belt-Clip Separation Distance - Mid Channel/Zoom Scan (5x5x7)/Cube 1:

Measurement grid: dx=8mm, dy=8mm, dz=5mm  
 Peak SAR (extrapolated) = 1.31 W/kg  
**SAR(1 g) = 0.566 mW/g; SAR(10 g) = 0.333 mW/g**  
 Reference Value = 27.9 V/m;  
 Power Drift = -1.06 dB

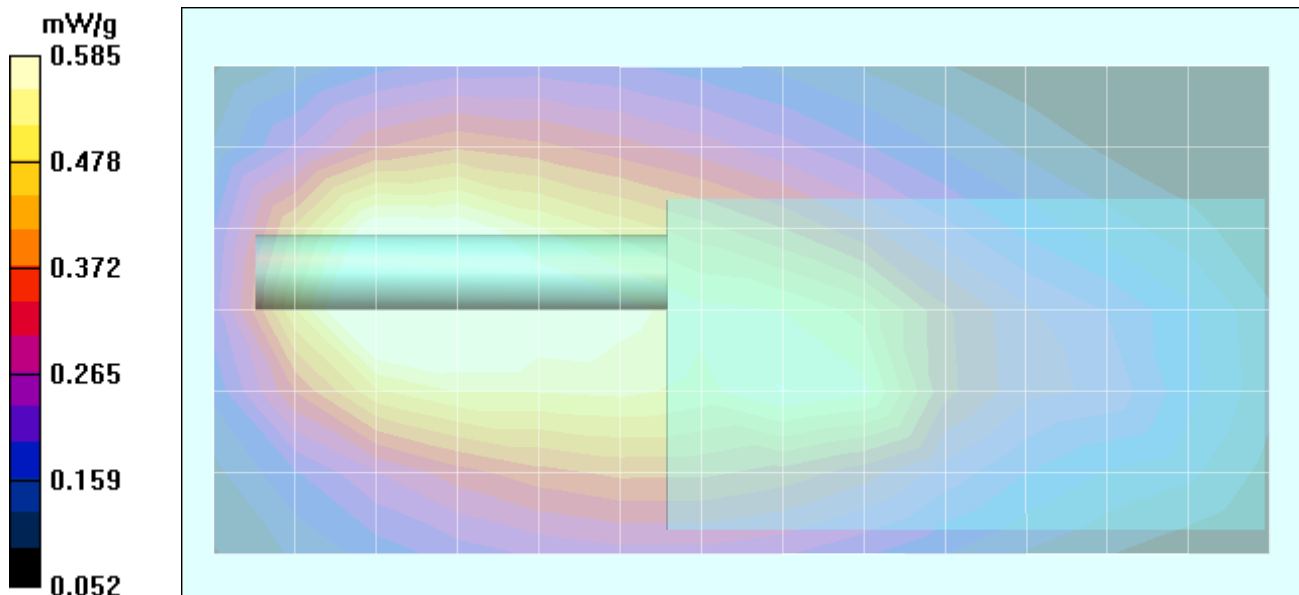

### SAR-versus-Time Power Drift Evaluation

Belt-Clip & Ear-Loop Microphone Accessory  
 7.2V Lithium-ion Battery (1250 mAh)  
 Mid Channel (160.15 MHz)

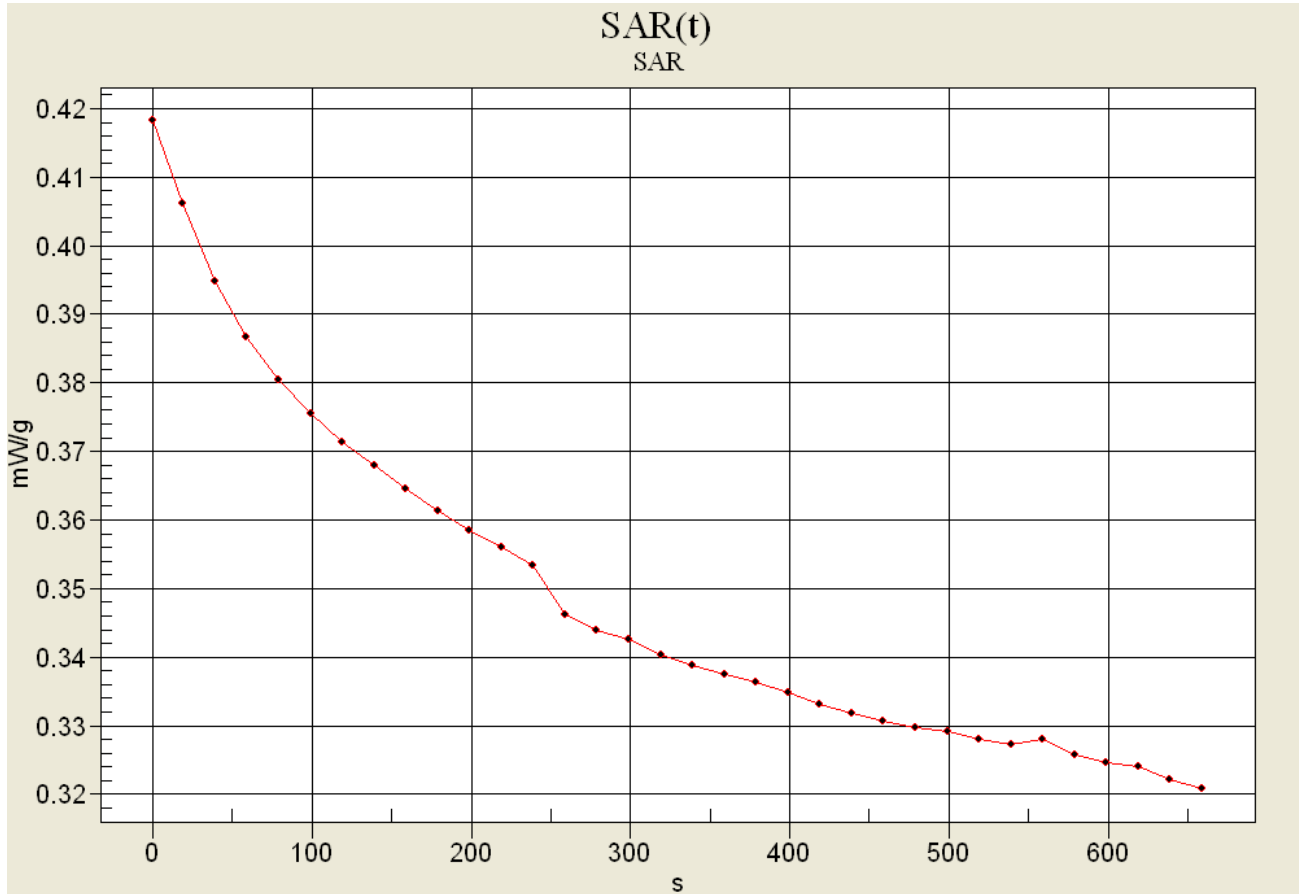

**Initial SAR: 0.418 mW/g**  
**End SAR: 0.320 mW/g (-1.16dB)**  
**SAR after 340s: 0.339 mW/g (-0.910dB)**  
**(340S: Zoom Scan Duration)**

Test Report S/N:	021804-480Q9S
Test Date(s):	February 25, 2004
Test Type:	FCC/IC SAR Evaluation

**APPENDIX B - SYSTEM PERFORMANCE CHECK DATA**



## System Performance Check - 300 MHz Dipole

Date Tested: 02/25/04

DUT: Dipole 300 MHz; Model: D300V2; Type: System Performance Check; Serial: 135

Ambient Temp: 25.1 °C; Fluid Temp: 22.3 °C; Barometric Pressure: 107.3 kPa; Humidity: 30%

Communication System: CW  
 Forward Conducted Power: 250mW  
 Frequency: 300 MHz; Duty Cycle: 1:1  
 Medium: 300 HSL ( $\sigma = 0.89$  mho/m;  $\epsilon_r = 45.6$ ;  $\rho = 1000$  kg/m<sup>3</sup>)

- Probe: ET3DV6 - SN1590; ConvF(8.3, 8.3, 8.3); Calibrated: 15/05/2003
- Sensor-Surface: 4mm (Mechanical Surface Detection)
- Electronics: DAE3 Sn353; Calibrated: 19/12/2003
- Phantom: Validation Planar; Type: Plexiglas; Serial: 137
- Measurement SW: DASY4, V4.2 Build 12; Postprocessing SW: SEMCAD, V1.8 Build 94

### 300 MHz System Performance Check/Area Scan (6x11x1):

Measurement grid: dx=15mm, dy=15mm

### 300 MHz System Performance Check/Zoom Scan (7x7x7)/Cube 0:

Measurement grid: dx=5mm, dy=5mm, dz=5mm  
 Peak SAR (extrapolated) = 1.34 W/kg  
**SAR(1 g) = 0.772 mW/g; SAR(10 g) = 0.503 mW/g**  
 Reference Value = 30.5 V/m  
 Power Drift = -0.1 dB

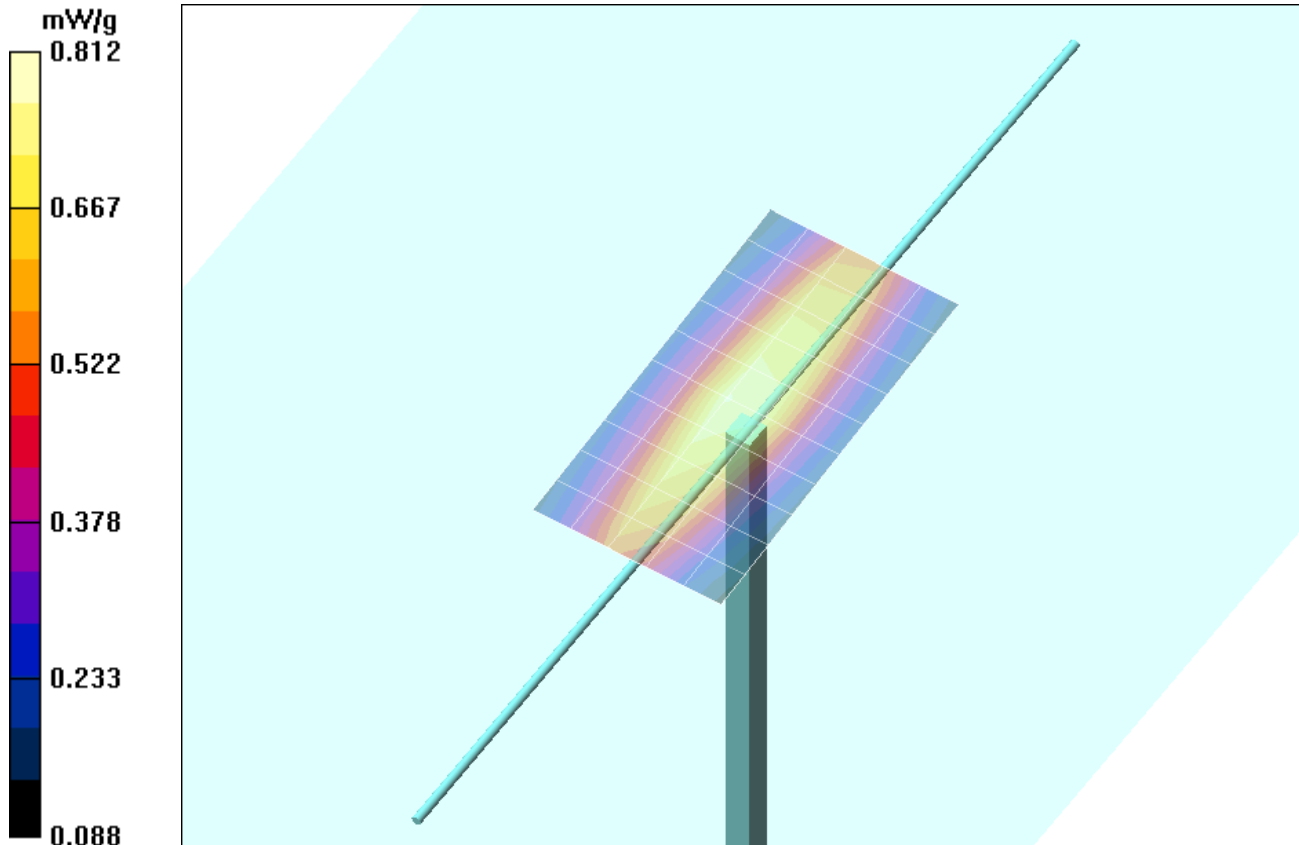

### Z-Axis Scan

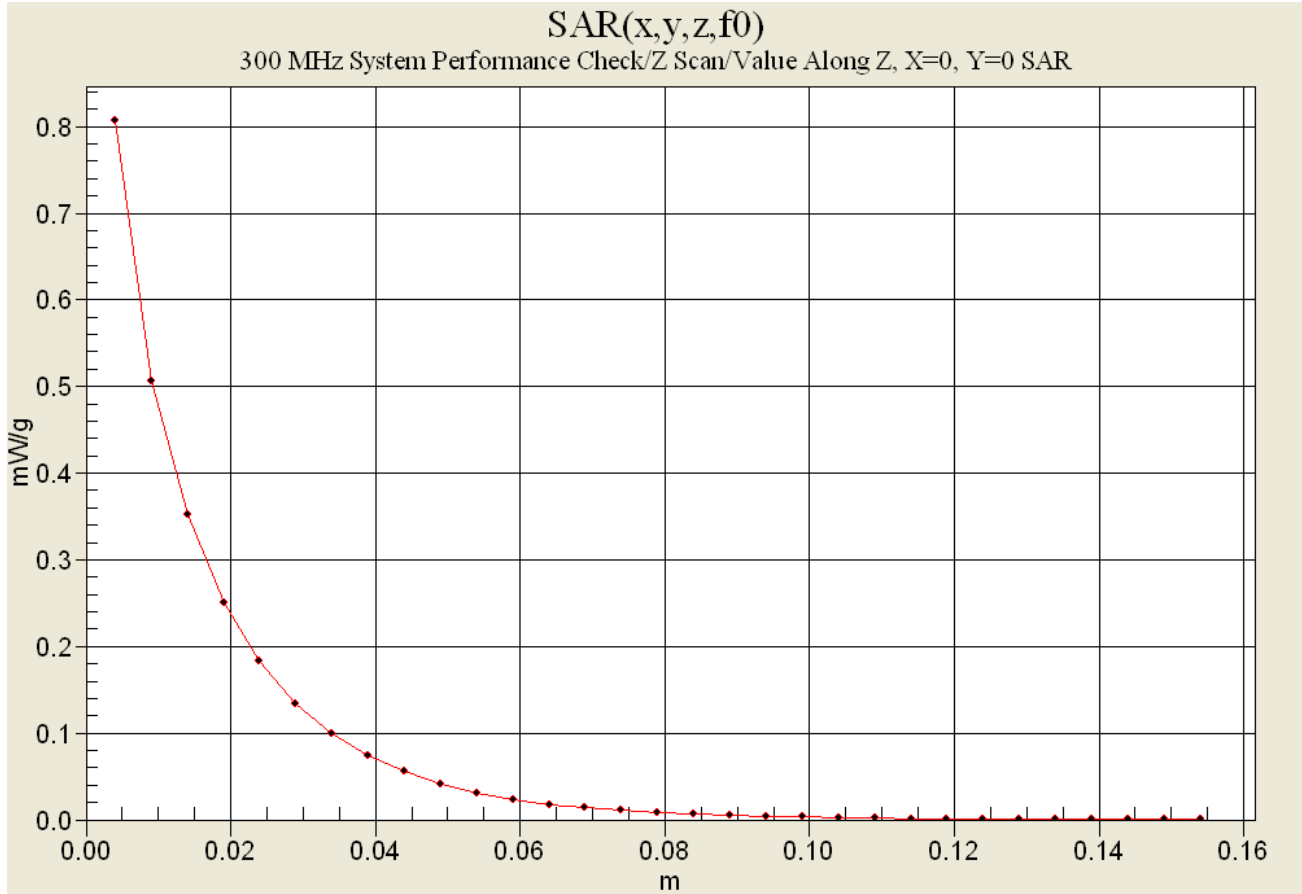

Test Report S/N:	021804-480Q9S
Test Date(s):	February 25, 2004
Test Type:	FCC/IC SAR Evaluation

## APPENDIX C - SYSTEM VALIDATION

## 300MHz SYSTEM VALIDATION DIPOLE

Type:

**300MHz Validation Dipole**

Serial Number:

**135**

Place of Calibration:

**Celltech Labs Inc.**

Date of Calibration:

**October 30, 2003**

Celltech Labs Inc. hereby certifies that this device has been calibrated on the date indicated above.

Calibrated by:

*Spencer Watson*

Approved by:

*Russell W. Pipe*

## 1. Validation Dipole Construction & Electrical Characteristics

The validation dipole was constructed in accordance with the IEEE Std. "Recommended Practice for Determining the Spatial-Peak Specific Absorption Rate (SAR) in the Human Body Due to Wireless Communications Devices: Experimental Techniques". The electrical properties were measured using an HP 8753E Network Analyzer. The network analyzer was calibrated to the validation dipole N-type connector feed point using an HP85032E Type N calibration kit. The dipole was placed parallel to a planar phantom at a separation distance of 15.0mm from the simulating fluid using a loss-less dielectric spacer. The measured input impedance is:

Feed point impedance at 300MHz	$\text{Re}\{Z\} = 43.586\Omega$
	$\text{Im}\{Z\} = -4.5313\Omega$
Return Loss at 300MHz	-21.693dB

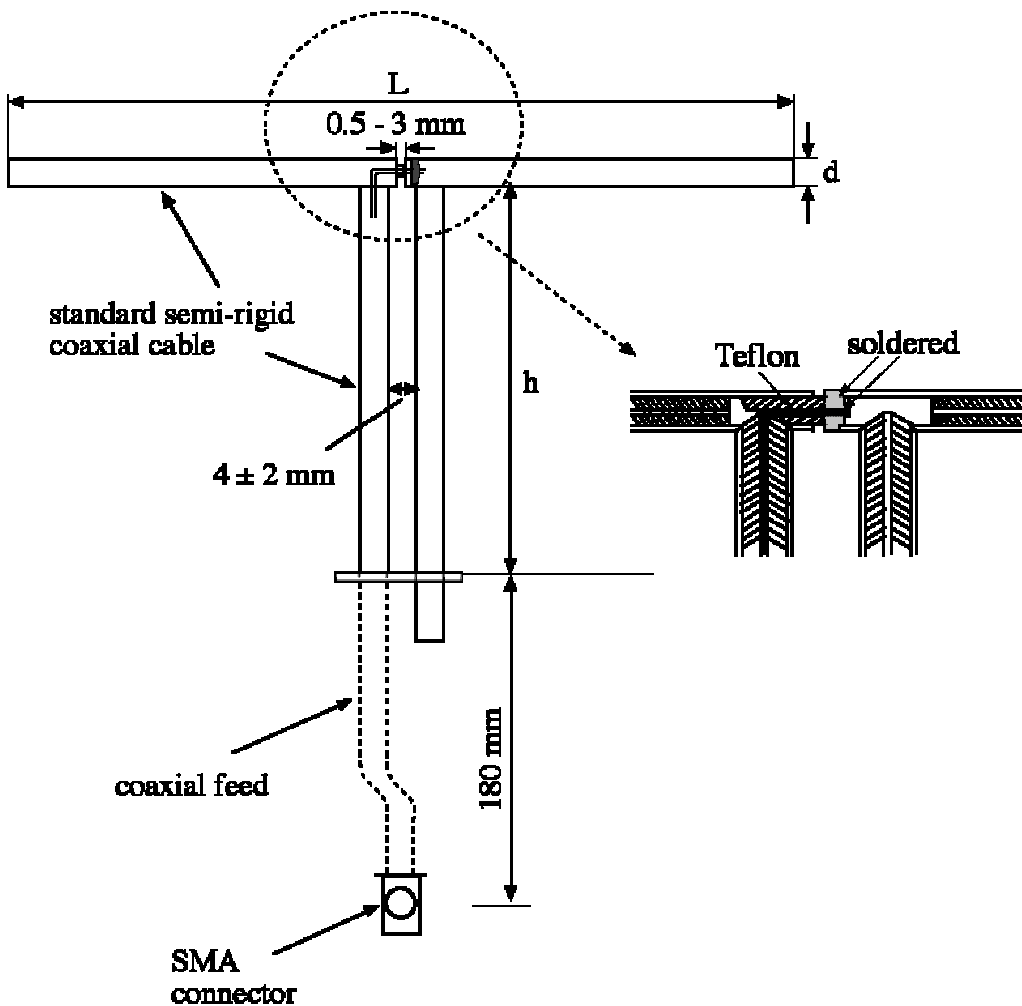

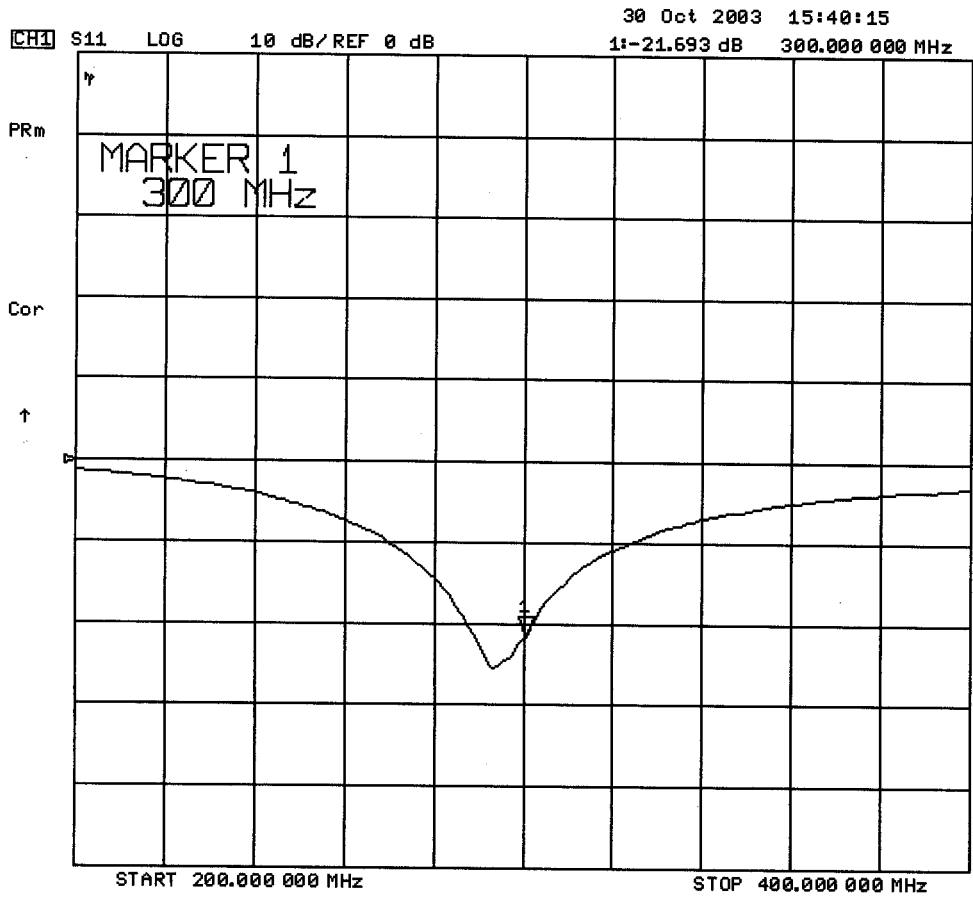

30 Oct 2003 15:41:51  
[CH1] S11 1 U FS 1: 43.586  $\Omega$  -4.5313  $\Omega$  117.08 pF 300.000 000 MHz

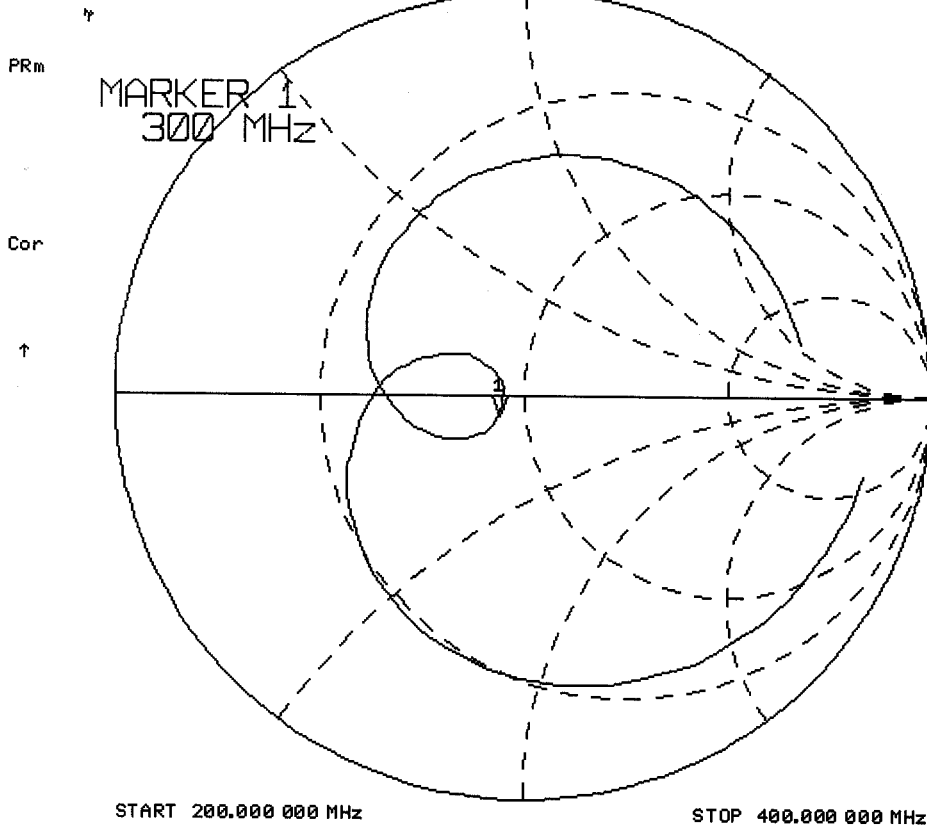

## 2. Validation Dipole Dimensions

Frequency (MHz)	L (mm)	H (mm)	D (mm)
300	420.0	250.0	6.2
450	288.0	167.0	6.2
835	161.0	89.8	3.6
900	149.0	83.3	3.6
1450	89.1	51.7	3.6
1800	72.0	41.7	3.6
1900	68.0	39.5	3.6
2000	64.5	37.5	3.6
2450	51.8	30.6	3.6
3000	41.5	25.0	3.6

## 3. Validation Phantom

The validation phantom was constructed using relatively low-loss tangent Plexiglas material. The inner dimensions of the phantom are as follows:

Length: 83.5 cm

Width: 36.9 cm

Height: 21.8 cm

The bottom section of the validation phantom is constructed of  $6.2 \pm 0.1$ mm Plexiglas.



#### 4. Dimensions of Plexiglas Planar Phantom

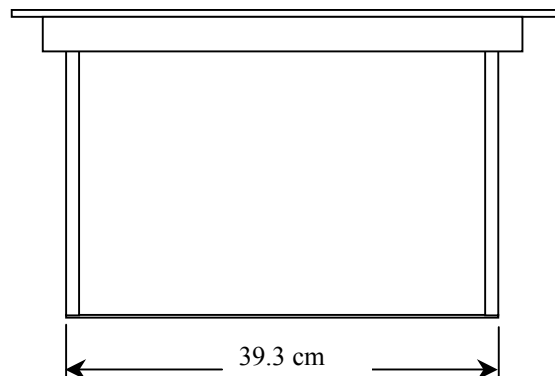
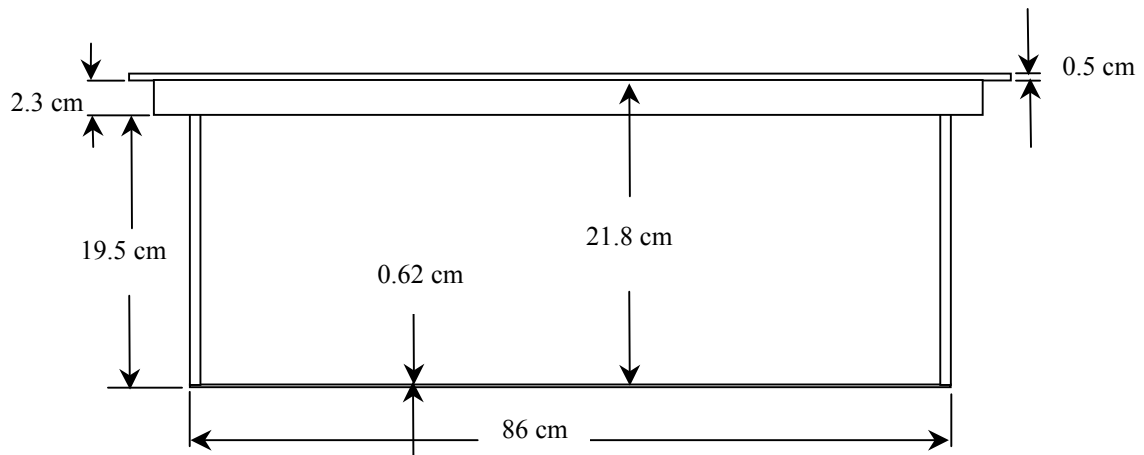
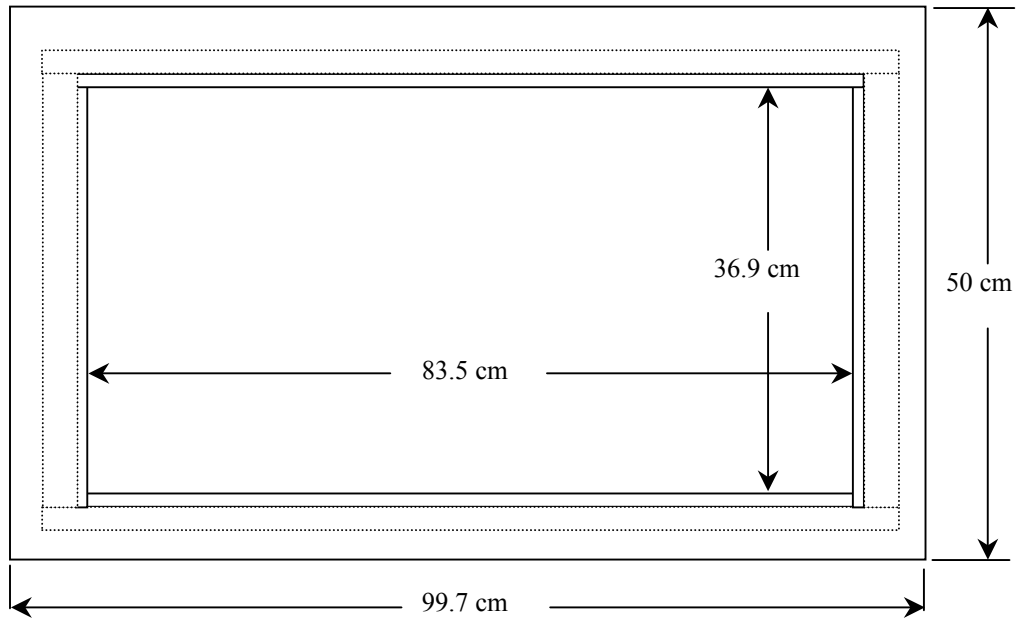

**5. 300MHz System Validation Setup**

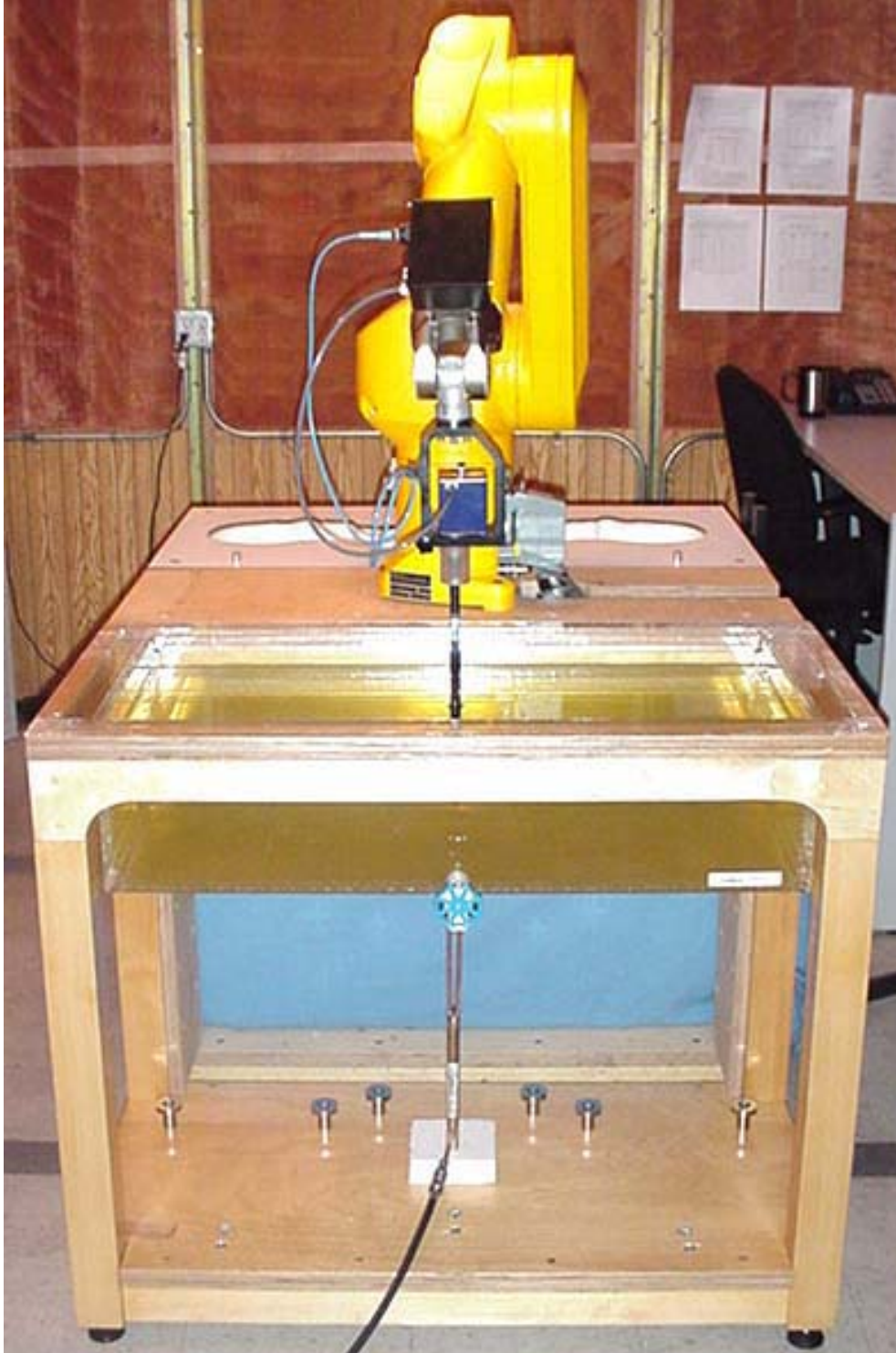

**300MHz System Validation Setup**



## 6. Measurement Conditions

The planar phantom was filled with simulated brain tissue having the following parameters at 300MHz:

Relative Permittivity:	45.7
Conductivity:	0.88 mho/m
Fluid Temperature:	22.2°C
Fluid Depth:	≥ 15cm

Environmental Conditions:

Ambient Temperature:	22.1°C
Humidity:	56%
Barometric Pressure:	103.4 kPa

The 300MHz simulated tissue mixture consists of the following ingredients:

<b>Ingredient</b>	<b>Percentage by weight</b>
Water	37.56%
Sugar	55.32%
Salt	5.95%
HEC	0.98%
Dowicil 75	0.19%
300MHz Target Dielectric Parameters at 22°C	$\epsilon_r = 45.3$ $\sigma = 0.87 \text{ S/m}$

## 7. SAR Measurement

The SAR measurement was performed with the E-field probe in mechanical detection mode only. The setup and determination of the forward power into the dipole was performed using the following procedures.

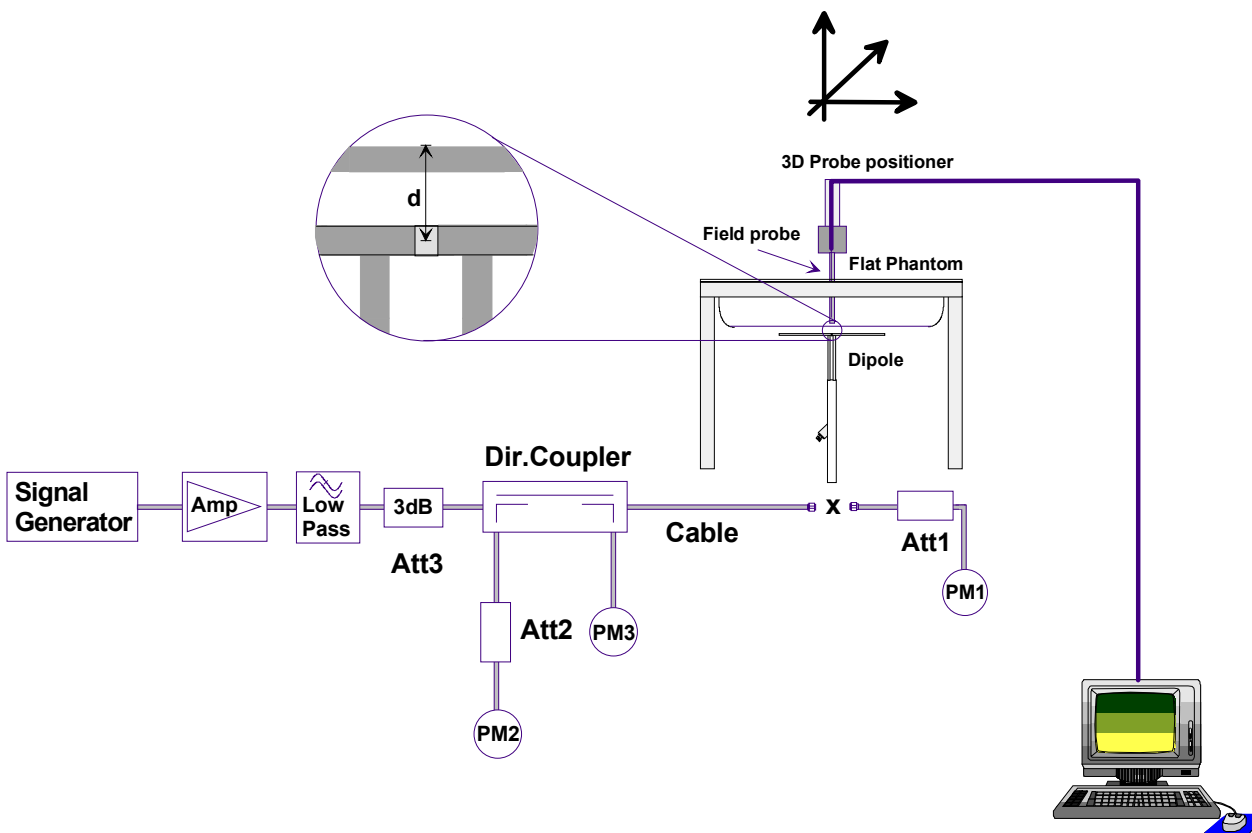

First the power meter PM1 (including attenuator Att1) is connected to the cable to measure the forward power at the location of the dipole connector (X). The signal generator is adjusted for the desired forward power at the dipole connector (taking into account the attenuation of Att1) as read by power meter PM2. After connecting the cable to the dipole, the signal generator is readjusted for the same reading at power meter PM2. If the signal generator does not allow adjustment in 0.01dB steps, the remaining difference at PM2 must be taken into consideration. PM3 records the reflected power from the dipole to ensure that the value is not changed from the previous value. The reflected power should be 20dB below the forward power.

## 8. Validation Dipole SAR Test Results

Ten SAR measurements were performed in order to achieve repeatability and to establish an average target value.

Validation Measurement	SAR @ 0.25W Input averaged over 1g	SAR @ 1W Input averaged over 1g	SAR @ 0.25W Input averaged over 10g	SAR @ 1W Input averaged over 10g	Peak SAR @ 0.25W Input
Test 1	0.781	3.12	0.497	1.99	1.39
Test 2	0.779	3.12	0.495	1.98	1.39
Test 3	0.780	3.12	0.496	1.98	1.38
Test 4	0.788	3.15	0.501	2.00	1.41
Test 5	0.787	3.15	0.498	1.99	1.39
Test 6	0.780	3.12	0.492	1.97	1.38
Test 7	0.776	3.10	0.494	1.98	1.37
Test 8	0.784	3.14	0.500	2.00	1.39
Test 9	0.785	3.14	0.500	2.00	1.39
Test 10	0.784	3.14	0.496	1.98	1.40
Average Value	0.782	3.13	0.497	1.99	1.39

The results have been normalized to 1W (forward power) into the dipole.

IEEE Target over 1cm<sup>3</sup> (1g) of tissue: 0.750 mW/g (+/- 10%)

Averaged over 1cm<sup>3</sup> (1g) of tissue: 3.13 mW/g

Averaged over 10cm<sup>3</sup> (10g) of tissue: 1.99 mW/g

Test Date: 10/30/03

DUT: Dipole 300 MHz; Model: D300V2; Type: System Validation; Serial: 135

Ambient Temp: 22.1°C; Fluid Temp: 22.2°C; Barometric Pressure: 103.4 kPa; Humidity: 56%

Communication System: CW  
Forward Conducted Power: 250 mW  
Frequency: 300 MHz; Duty Cycle: 1:1  
Medium: 300 HSL ( $\sigma = 0.88$  mho/m,  $\epsilon_r = 45.7$ ,  $\rho = 1000$  kg/m<sup>3</sup>)

- Probe: ET3DV6 - SN1387; ConvF(7.9, 7.9, 7.9); Calibrated: 26/02/2003
- Sensor-Surface: 4mm (Mechanical Surface Detection)
- Electronics: DAE3 Sn370; Calibrated: 19/05/2003
- Phantom: Validation Planar; Type: Plexiglas; Serial: 137
- Measurement SW: DASY4, V4.1 Build 47; Postprocessing SW: SEMCAD, V1.6 Build 116

**300 MHz Validation/Area Scan (6x11x1):** Measurement grid: dx=15mm, dy=15mm  
Reference Value = 30.4 V/m  
Power Drift = -0.1 dB

**300 MHz Validation/Zoom Scan (7x7x7)/Cube 0:** Measurement grid: dx=5mm, dy=5mm, dz=5mm  
Peak SAR (extrapolated) = 1.39 W/kg  
**SAR(1 g) = 0.781 mW/g; SAR(10 g) = 0.497 mW/g**  
Reference Value = 30.4 V/m  
Power Drift = -0.1 dB

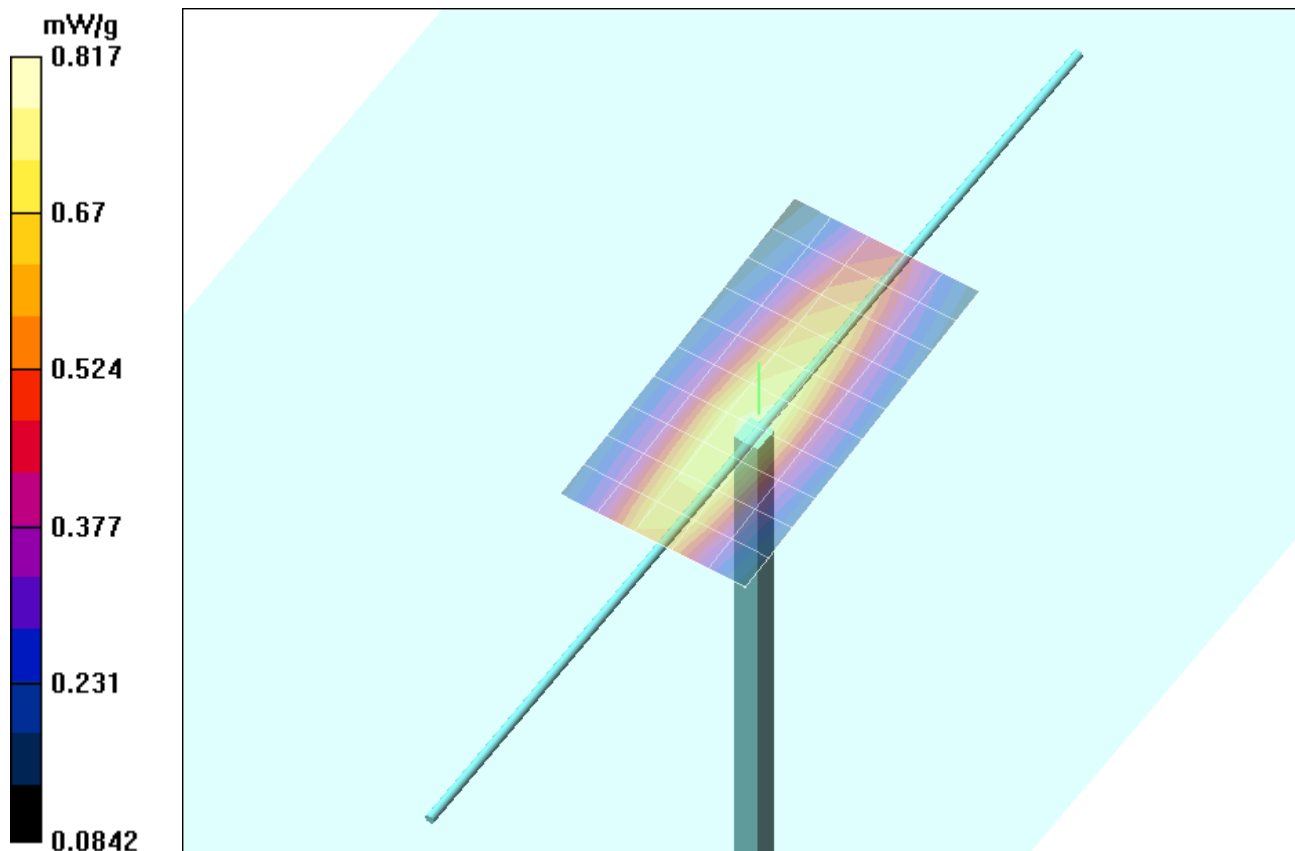

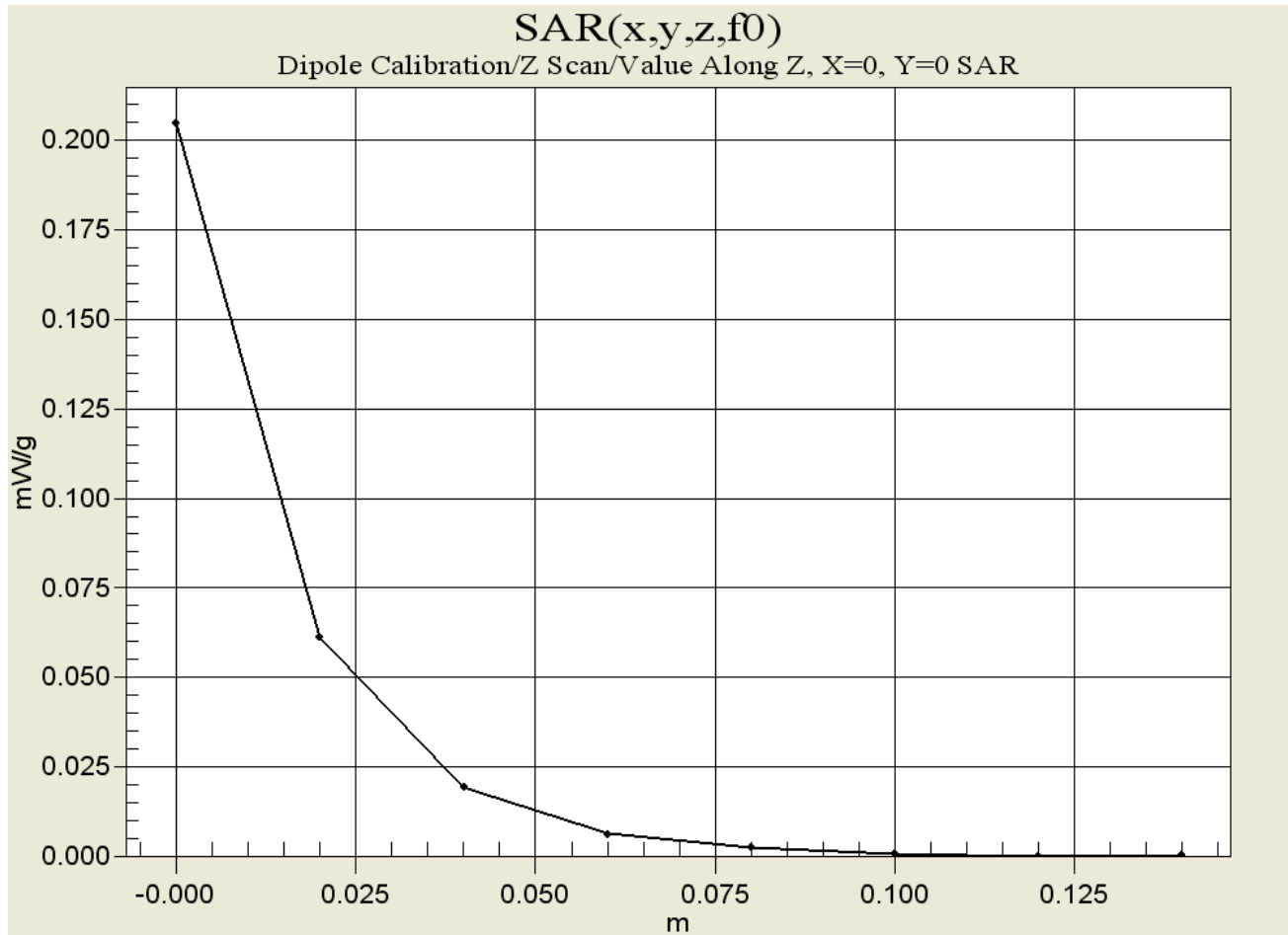



# 300MHz System Validation

## Measured Fluid Dielectric Parameters (Brain)



October 30, 2003

Frequency	$\epsilon'$	$\epsilon''$
200.000000 MHz	49.8336	71.7361
210.000000 MHz	49.2398	69.1403
220.000000 MHz	48.9026	66.6656
230.000000 MHz	48.4363	64.3972
240.000000 MHz	47.9018	62.2373
250.000000 MHz	47.4646	60.4416
260.000000 MHz	47.0839	58.8112
270.000000 MHz	46.6772	57.3352
280.000000 MHz	46.4143	55.8759
290.000000 MHz	46.0204	54.5734
300.000000 MHz	45.6863	52.9882
310.000000 MHz	45.3261	51.7924
320.000000 MHz	44.9882	50.6430
330.000000 MHz	44.6549	49.5121
340.000000 MHz	44.3168	48.5356
350.000000 MHz	44.0824	47.5910
360.000000 MHz	43.7780	46.7661
370.000000 MHz	43.5461	45.8627
380.000000 MHz	43.3671	45.0444
390.000000 MHz	43.1052	44.2129
400.000000 MHz	42.8360	43.5735

Test Report S/N:	021804-480Q9S
Test Date(s):	February 25, 2004
Test Type:	FCC/IC SAR Evaluation

## APPENDIX D - PROBE CALIBRATION

Client **Celltech Labs**

CALIBRATION CERTIFICATE																															
Object(s)	ET3DV6 - SN:1590																														
Calibration procedure(s)	QA CAL-01.v2 Calibration procedure for dosimetric E-field probes																														
Calibration date:	May 15, 2003																														
Condition of the calibrated item	In Tolerance (according to the specific calibration document)																														
<p>This calibration statement documents traceability of M&amp;TE used in the calibration procedures and conformity of the procedures with the ISO/IEC 17025 international standard.</p> <p>All calibrations have been conducted in the closed laboratory facility: environment temperature 22 +/- 2 degrees Celsius and humidity &lt; 75%.</p> <p>Calibration Equipment used (M&amp;TE critical for calibration)</p> <table border="1"> <thead> <tr> <th>Model Type</th> <th>ID #</th> <th>Cal Date (Calibrated by, Certificate No.)</th> <th>Scheduled Calibration</th> </tr> </thead> <tbody> <tr> <td>RF generator HP 8684C</td> <td>US3642U01700</td> <td>4-Aug-99 (SPEAG, in house check Aug-02)</td> <td>In house check: Aug-05</td> </tr> <tr> <td>Power sensor E4412A</td> <td>MY41495277</td> <td>2-Apr-03 (METAS, No 252-0250)</td> <td>Apr-04</td> </tr> <tr> <td>Power sensor HP 8481A</td> <td>MY41092180</td> <td>18-Sep-02 (Agilent, No. 20020918)</td> <td>Sep-03</td> </tr> <tr> <td>Power meter EPM E4419B</td> <td>GB41293874</td> <td>2-Apr-03 (METAS, No 252-0250)</td> <td>Apr-04</td> </tr> <tr> <td>Network Analyzer HP 8753E</td> <td>US38432426</td> <td>3-May-00 (Agilent, No. 8702K094602)</td> <td>In house check: May 03</td> </tr> <tr> <td>Fluke Process Calibrator Type 702</td> <td>SN: 6295803</td> <td>3-Sep-01 (ELCAL, No.2360)</td> <td>Sep-03</td> </tr> </tbody> </table>				Model Type	ID #	Cal Date (Calibrated by, Certificate No.)	Scheduled Calibration	RF generator HP 8684C	US3642U01700	4-Aug-99 (SPEAG, in house check Aug-02)	In house check: Aug-05	Power sensor E4412A	MY41495277	2-Apr-03 (METAS, No 252-0250)	Apr-04	Power sensor HP 8481A	MY41092180	18-Sep-02 (Agilent, No. 20020918)	Sep-03	Power meter EPM E4419B	GB41293874	2-Apr-03 (METAS, No 252-0250)	Apr-04	Network Analyzer HP 8753E	US38432426	3-May-00 (Agilent, No. 8702K094602)	In house check: May 03	Fluke Process Calibrator Type 702	SN: 6295803	3-Sep-01 (ELCAL, No.2360)	Sep-03
Model Type	ID #	Cal Date (Calibrated by, Certificate No.)	Scheduled Calibration																												
RF generator HP 8684C	US3642U01700	4-Aug-99 (SPEAG, in house check Aug-02)	In house check: Aug-05																												
Power sensor E4412A	MY41495277	2-Apr-03 (METAS, No 252-0250)	Apr-04																												
Power sensor HP 8481A	MY41092180	18-Sep-02 (Agilent, No. 20020918)	Sep-03																												
Power meter EPM E4419B	GB41293874	2-Apr-03 (METAS, No 252-0250)	Apr-04																												
Network Analyzer HP 8753E	US38432426	3-May-00 (Agilent, No. 8702K094602)	In house check: May 03																												
Fluke Process Calibrator Type 702	SN: 6295803	3-Sep-01 (ELCAL, No.2360)	Sep-03																												
Calibrated by:	Name Nicola Vetterli	Function Technician	Signature 																												
Approved by:	Name Katja Polovic	Function Laboratory Director	Signature 																												
Date issued: May 15, 2003																															
<p>This calibration certificate is issued as an intermediate solution until the accreditation process (based on ISO/IEC 17025 International Standard) for Calibration Laboratory of Schmid &amp; Partner Engineering AG is completed.</p>																															

# Probe ET3DV6

SN:1590

Manufactured:	March 19, 2001
Last calibration:	April 26, 2002
Recalibrated:	May 15, 2003

Calibrated for DASY Systems

(Note: non-compatible with DASY2 system!)

**DASY - Parameters of Probe: ET3DV6 SN:1590****Sensitivity in Free Space**

NormX	<b>1.76</b> $\mu\text{V}/(\text{V}/\text{m})^2$
NormY	<b>1.91</b> $\mu\text{V}/(\text{V}/\text{m})^2$
NormZ	<b>1.66</b> $\mu\text{V}/(\text{V}/\text{m})^2$

**Diode Compression**

DCP X	<b>92</b>	mV
DCP Y	<b>92</b>	mV
DCP Z	<b>92</b>	mV

**Sensitivity in Tissue Simulating Liquid**

Head                      900 MHz                       $\epsilon_r = 41.5 \pm 5\%$                        $\sigma = 0.97 \pm 5\%$  mho/m

Valid for f=800-1000 MHz with Head Tissue Simulating Liquid according to EN 50361, P1528-200X

ConvF X	<b>7.0</b> $\pm 9.5\%$ (k=2)	Boundary effect:
ConvF Y	<b>7.0</b> $\pm 9.5\%$ (k=2)	Alpha <b>0.33</b>
ConvF Z	<b>7.0</b> $\pm 9.5\%$ (k=2)	Depth <b>2.56</b>

Head                      1800 MHz                       $\epsilon_r = 40.0 \pm 5\%$                        $\sigma = 1.40 \pm 5\%$  mho/m

Valid for f=1710-1910 MHz with Head Tissue Simulating Liquid according to EN 50361, P1528-200X

ConvF X	<b>5.5</b> $\pm 9.5\%$ (k=2)	Boundary effect:
ConvF Y	<b>5.5</b> $\pm 9.5\%$ (k=2)	Alpha <b>0.44</b>
ConvF Z	<b>5.5</b> $\pm 9.5\%$ (k=2)	Depth <b>2.69</b>

**Boundary Effect**

Head                      900 MHz                      Typical SAR gradient: 5 % per mm

Probe Tip to Boundary		<b>1 mm</b>	<b>2 mm</b>
SAR <sub>be</sub> [%]	Without Correction Algorithm	8.7	5.0
SAR <sub>be</sub> [%]	With Correction Algorithm	0.3	0.5

Head                      1800 MHz                      Typical SAR gradient: 10 % per mm

Probe Tip to Boundary		<b>1 mm</b>	<b>2 mm</b>
SAR <sub>be</sub> [%]	Without Correction Algorithm	12.3	8.5
SAR <sub>be</sub> [%]	With Correction Algorithm	0.2	0.1

**Sensor Offset**

Probe Tip to Sensor Center	<b>2.7</b>	mm
Optical Surface Detection	<b>1.4 <math>\pm</math> 0.2</b>	mm

### Receiving Pattern ( $\phi$ ), $\theta = 0^\circ$

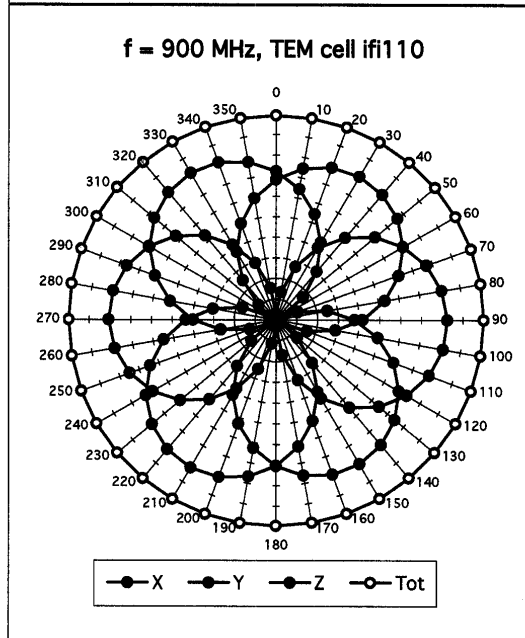
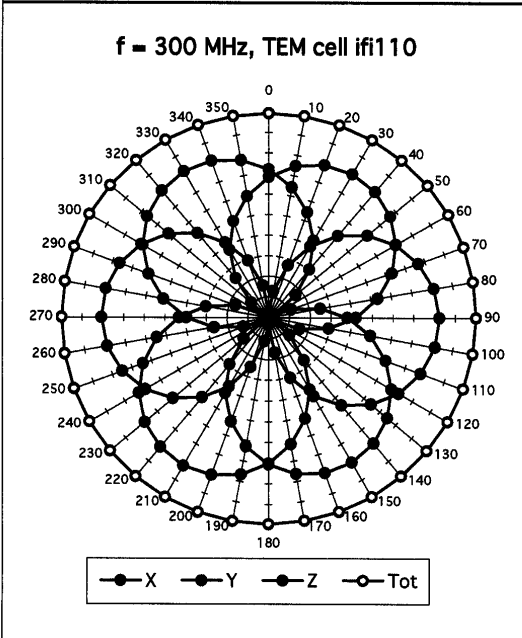
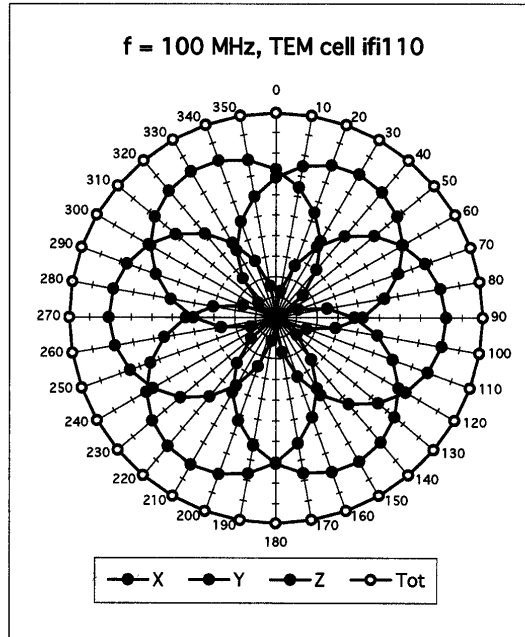
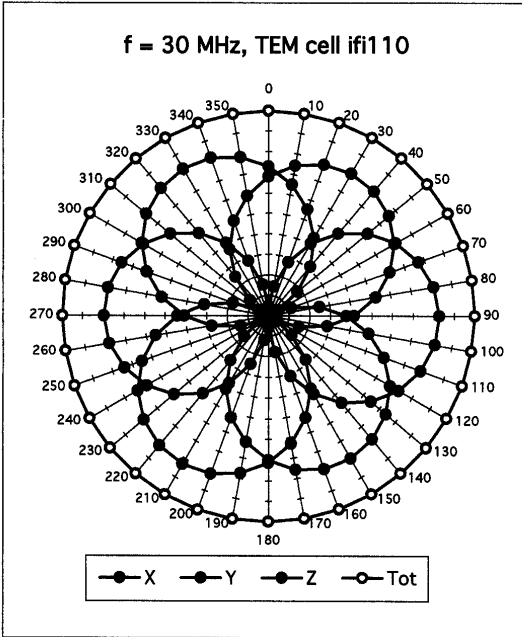

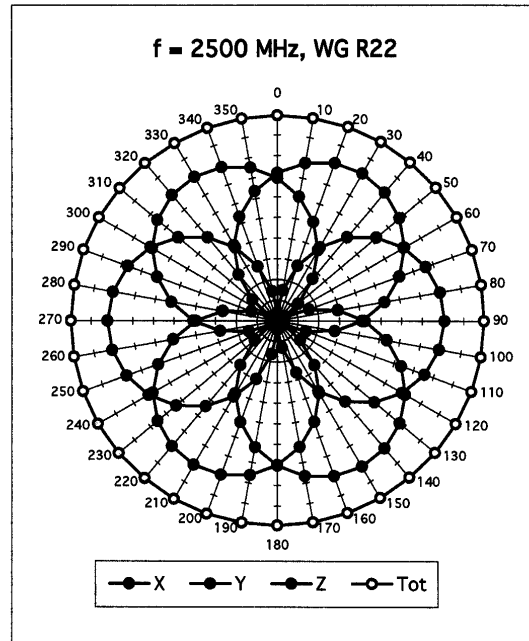
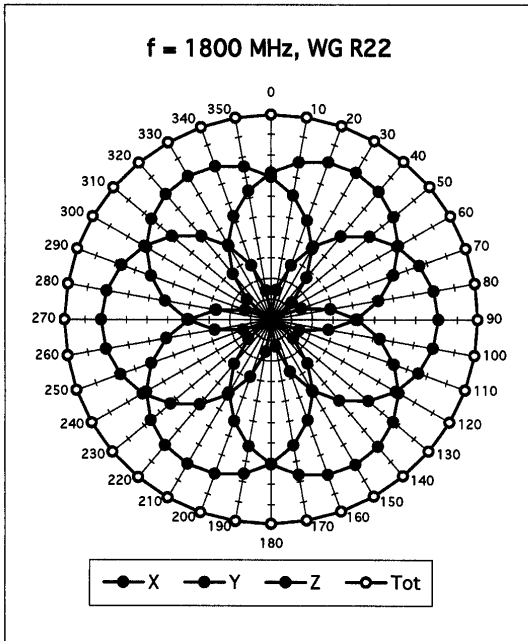

**Isotropy Error ( $\phi$ ),  $\theta = 0^\circ$**

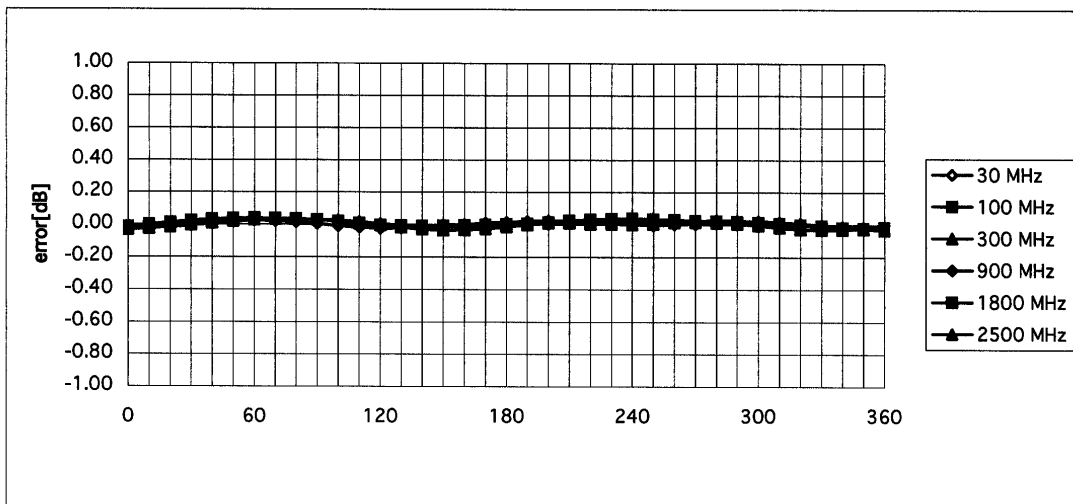

### Frequency Response of E-Field

( TEM-Cell:ifi110, Waveguide R22)

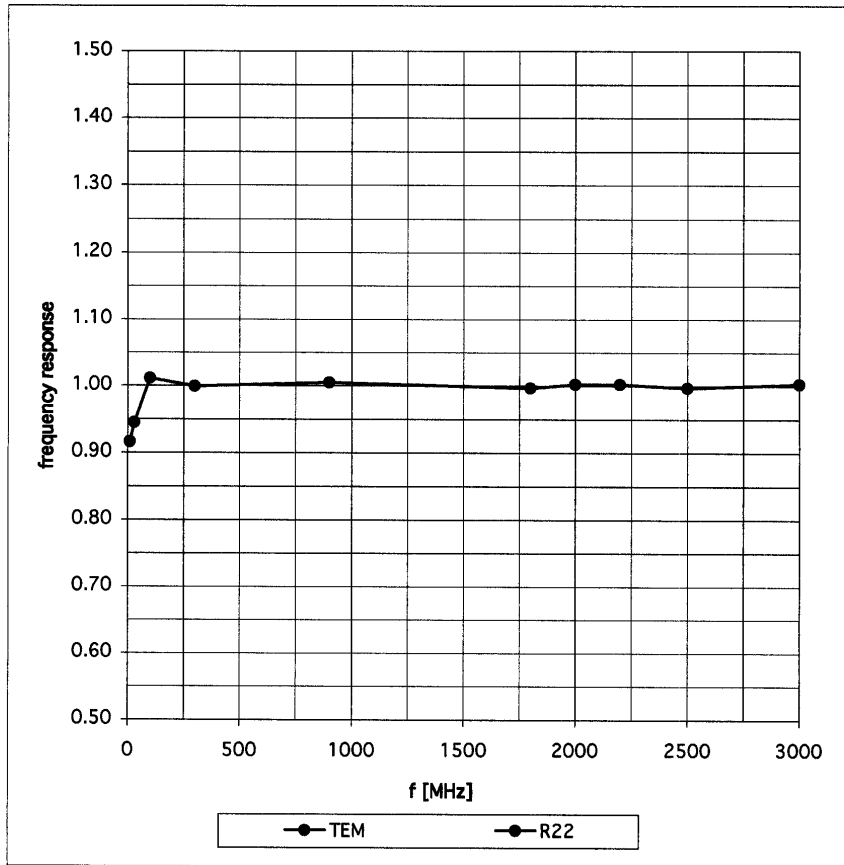



### Dynamic Range f(SAR<sub>brain</sub>)

( Waveguide R22 )

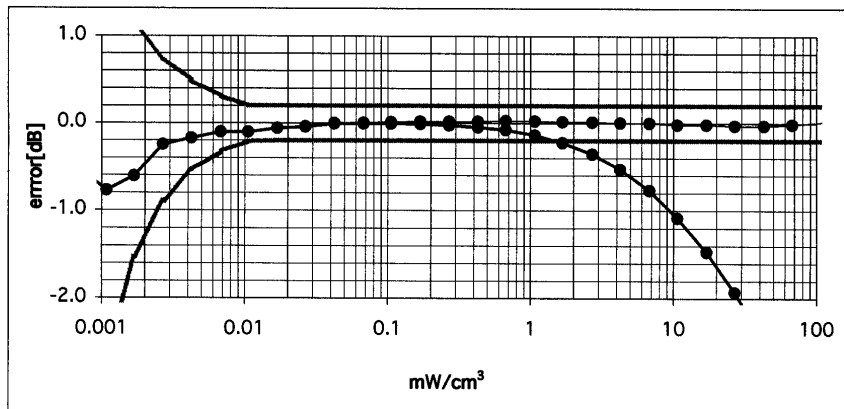
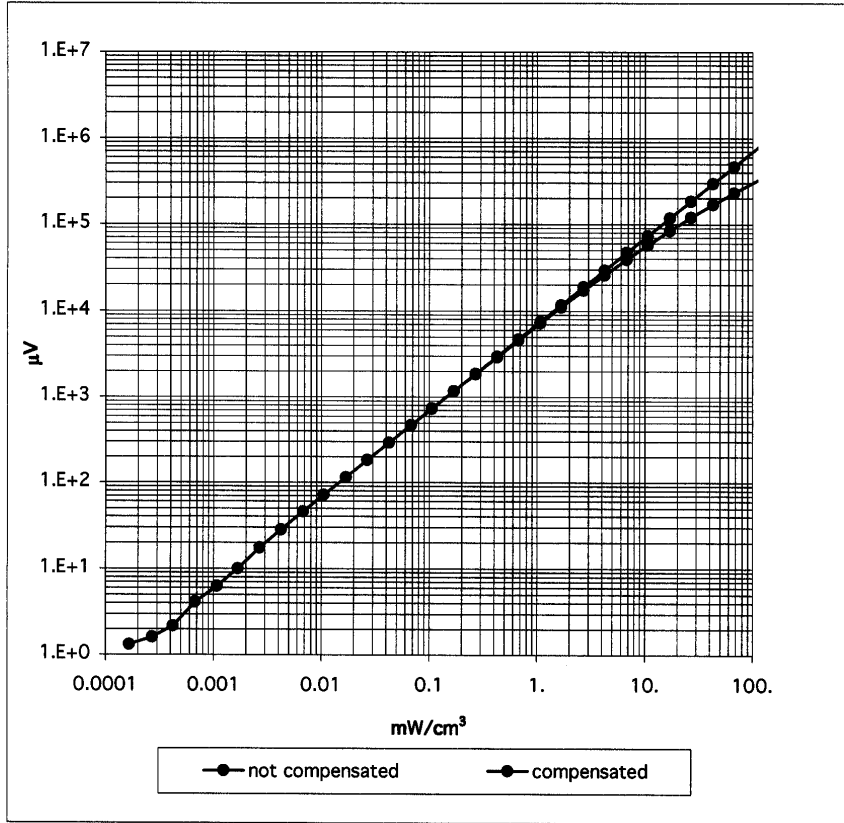

### Conversion Factor Assessment

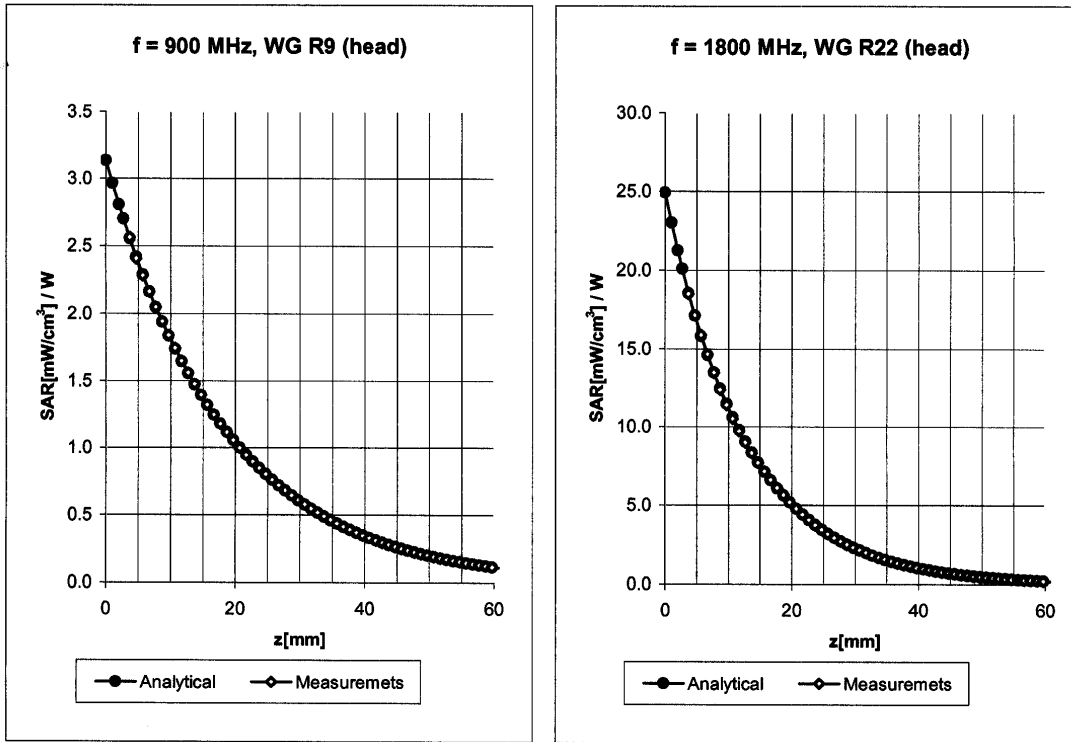

Head                      900 MHz                       $\epsilon_r = 41.5 \pm 5\%$                        $\sigma = 0.97 \pm 5\%$  mho/m

Valid for f=800-1000 MHz with Head Tissue Simulating Liquid according to EN 50361, P1528-200X

ConvF X	7.0 ± 9.5% (k=2)	Boundary effect:	
ConvF Y	7.0 ± 9.5% (k=2)	Alpha	<b>0.33</b>
ConvF Z	7.0 ± 9.5% (k=2)	Depth	<b>2.56</b>

Head                      1800 MHz                       $\epsilon_r = 40.0 \pm 5\%$                        $\sigma = 1.40 \pm 5\%$  mho/m

Valid for f=1710-1910 MHz with Head Tissue Simulating Liquid according to EN 50361, P1528-200X

ConvF X	5.5 ± 9.5% (k=2)	Boundary effect:	
ConvF Y	5.5 ± 9.5% (k=2)	Alpha	<b>0.44</b>
ConvF Z	5.5 ± 9.5% (k=2)	Depth	<b>2.69</b>

### Conversion Factor Assessment

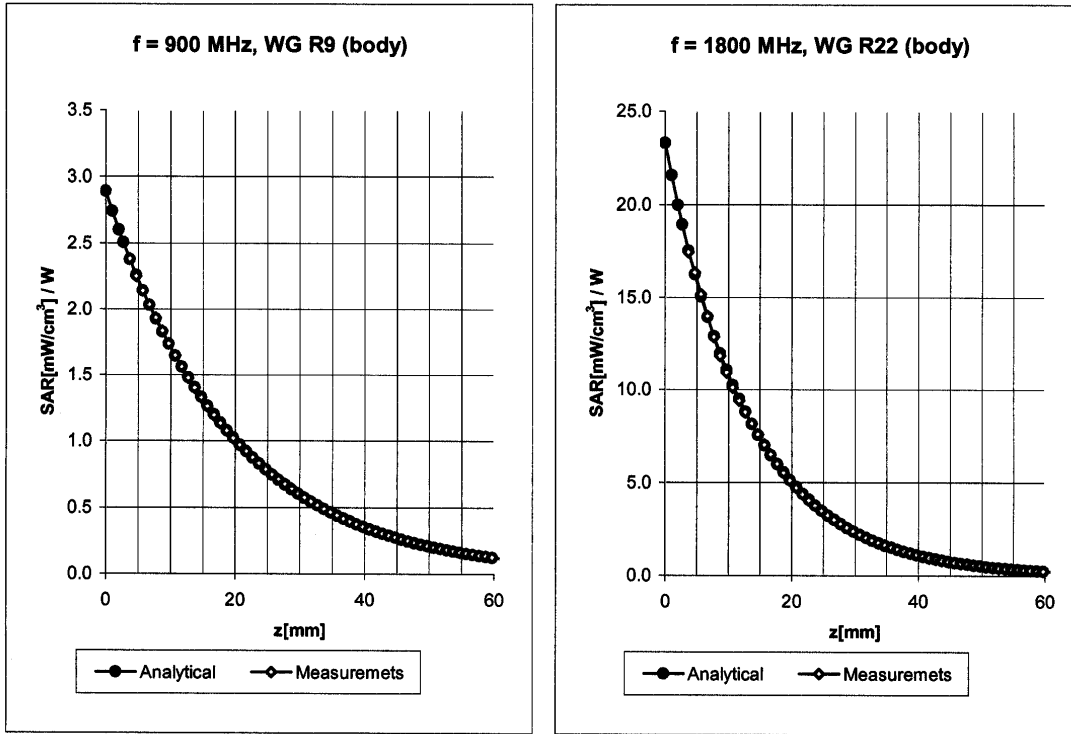

Body                      900 MHz                       $\epsilon_r = 55.0 \pm 5\%$                        $\sigma = 1.05 \pm 5\%$  mho/m

Valid for f=800-1000 MHz with Body Tissue Simulating Liquid according to OET 65 Suppl. C

ConvF X	<b>6.8</b> $\pm 9.5\%$ (k=2)	Boundary effect:
ConvF Y	<b>6.8</b> $\pm 9.5\%$ (k=2)	Alpha <b>0.34</b>
ConvF Z	<b>6.8</b> $\pm 9.5\%$ (k=2)	Depth <b>2.61</b>

Body                      1800 MHz                       $\epsilon_r = 53.3 \pm 5\%$                        $\sigma = 1.52 \pm 5\%$  mho/m

Valid for f=1710-1910 MHz with Body Tissue Simulating Liquid according to OET 65 Suppl. C

ConvF X	<b>5.0</b> $\pm 9.5\%$ (k=2)	Boundary effect:
ConvF Y	<b>5.0</b> $\pm 9.5\%$ (k=2)	Alpha <b>0.52</b>
ConvF Z	<b>5.0</b> $\pm 9.5\%$ (k=2)	Depth <b>2.69</b>

### Conversion Factor Assessment

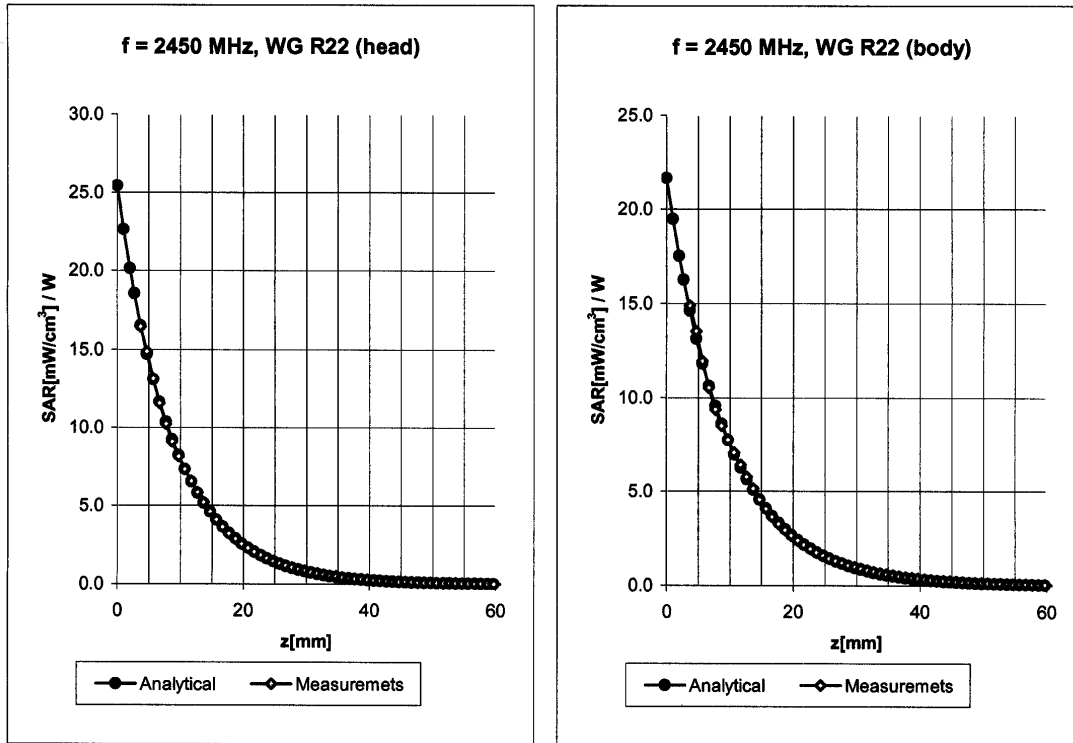

Head      2450      MHz       $\epsilon_r = 39.2 \pm 5\%$        $\sigma = 1.80 \pm 5\%$  mho/m

Valid for f=2400-2500 MHz with Head Tissue Simulating Liquid according to EN 50361, P1528-200X

ConvF X	5.0 ± 8.9% (k=2)	Boundary effect:	
ConvF Y	5.0 ± 8.9% (k=2)	Alpha	<b>0.88</b>
ConvF Z	5.0 ± 8.9% (k=2)	Depth	<b>1.92</b>

Body      2450      MHz       $\epsilon_r = 52.7 \pm 5\%$        $\sigma = 1.95 \pm 5\%$  mho/m

Valid for f=2400-2500 MHz with Body Tissue Simulating Liquid according to OET 65 Suppl. C

ConvF X	4.4 ± 8.9% (k=2)	Boundary effect:	
ConvF Y	4.4 ± 8.9% (k=2)	Alpha	<b>0.90</b>
ConvF Z	4.4 ± 8.9% (k=2)	Depth	<b>1.87</b>

### Deviation from Isotropy in HSL

Error ( $\theta, \phi$ ),  $f = 900$  MHz

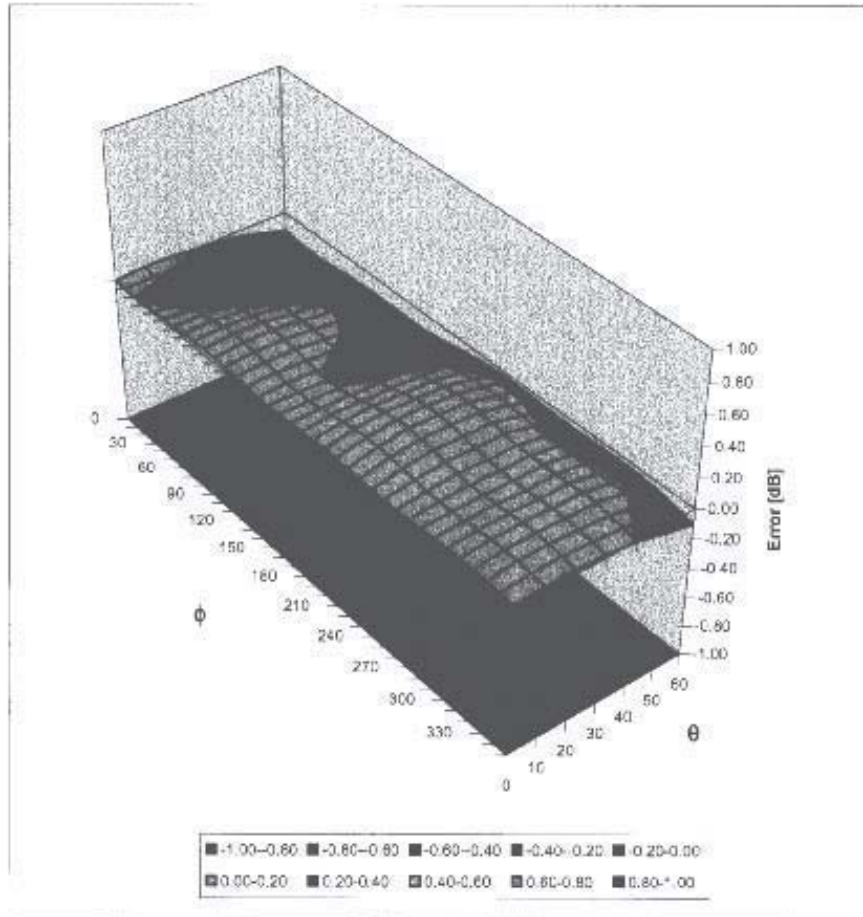

## Additional Conversion Factors for Dosimetric E-Field Probe

Type:

**ET3DV6**

Serial Number:

**1590**

Place of Assessment:

**Zurich**

Date of Assessment:

**May 19, 2003**

Probe Calibration Date:

**May 15, 2003**

Schmid & Partner Engineering AG hereby certifies that conversion factor(s) of this probe have been evaluated on the date indicated above. The assessment was performed using the FDTD numerical code SEMCAD of Schmid & Partner Engineering AG. Since the evaluation is coupled with measured conversion factors, it has to be recalculated yearly, i.e., following the re-calibration schedule of the probe. The uncertainty of the numerical assessment is based on the extrapolation from measured value at 900 MHz or at 1800 MHz.

Assessed by:

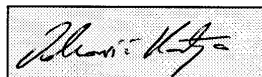

## Dosimetric E-Field Probe ET3DV6 SN:1590

Conversion factor ( $\pm$  standard deviation)

150 MHz	ConvF	9.6 $\pm$ 8%	$\epsilon_r = 52.3 \pm 5\%$ $\sigma = 0.76 \pm 5\%$ mho/m (head tissue)
300 MHz	ConvF	8.3 $\pm$ 8%	$\epsilon_r = 45.3 \pm 5\%$ $\sigma = 0.87 \pm 5\%$ mho/m (head tissue)
450 MHz	ConvF	7.9 $\pm$ 8%	$\epsilon_r = 43.5 \pm 5\%$ $\sigma = 0.87 \pm 5\%$ mho/m (head tissue)
150 MHz	ConvF	9.2 $\pm$ 8%	$\epsilon_r = 61.9 \pm 5\%$ $\sigma = 0.80 \pm 5\%$ mho/m (body tissue)
450 MHz	ConvF	8.1 $\pm$ 8%	$\epsilon_r = 56.7 \pm 5\%$ $\sigma = 0.94 \pm 5\%$ mho/m (body tissue)

Test Report S/N:	021804-480Q9S
Test Date(s):	February 25, 2004
Test Type:	FCC/IC SAR Evaluation

## APPENDIX E - MEASURED FLUID DIELECTRIC PARAMETERS



# 300 MHz System Performance Check

## Measured Fluid Dielectric Parameters (Brain)

February 25, 2004

Frequency	$\epsilon'$	$\epsilon''$
200.000000 MHz	49.6141	72.6215
210.000000 MHz	49.0821	69.8629
220.000000 MHz	48.6106	67.4443
230.000000 MHz	48.2533	65.1897
240.000000 MHz	47.6861	63.1060
250.000000 MHz	47.3210	61.2216
260.000000 MHz	46.8781	59.5052
270.000000 MHz	46.5266	58.0005
280.000000 MHz	46.1877	56.4375
290.000000 MHz	45.8042	55.1314
300.000000 MHz	45.5831	53.5874
310.000000 MHz	45.1442	52.3553
320.000000 MHz	44.8638	51.1706
330.000000 MHz	44.5257	50.0513
340.000000 MHz	44.2706	49.0880
350.000000 MHz	43.9793	48.1357
360.000000 MHz	43.7081	47.2460
370.000000 MHz	43.4325	46.3248
380.000000 MHz	43.2318	45.5546
390.000000 MHz	42.9071	44.6980
400.000000 MHz	42.6744	43.9580

# 150 MHz DUT Evaluation (Face)

## Measured Fluid Dielectric Parameters (Brain)

February 25, 2004

Frequency	$\epsilon'$	$\epsilon''$
50.000000 MHz	61.8922	234.2374
60.000000 MHz	60.5058	197.3109
70.000000 MHz	60.3364	170.8169
80.000000 MHz	58.6800	151.5277
90.000000 MHz	58.1075	136.0738
100.000000 MHz	56.9173	124.2908
110.000000 MHz	55.9873	114.5249
120.000000 MHz	55.1410	106.1072
130.000000 MHz	54.6395	99.3059
140.000000 MHz	53.8977	92.9593
150.000000 MHz	53.2435	88.0495
160.000000 MHz	52.8172	83.5061
170.000000 MHz	52.2369	79.5756
180.000000 MHz	51.8175	75.7490
190.000000 MHz	51.3986	72.5374
200.000000 MHz	50.9163	69.5463
210.000000 MHz	50.4906	66.9121
220.000000 MHz	50.1430	64.6966
230.000000 MHz	49.5700	62.5663
240.000000 MHz	49.2305	60.5238
250.000000 MHz	48.7144	58.7265

# 150 MHz DUT Evaluation (Body)

## Measured Fluid Dielectric Parameters (Muscle)

February 25, 2004

Frequency	$\epsilon'$	$\epsilon''$
50.000000 MHz	68.3357	260.8900
60.000000 MHz	66.9113	219.0172
70.000000 MHz	66.0652	188.5930
80.000000 MHz	64.7419	166.1757
90.000000 MHz	63.5530	148.9941
100.000000 MHz	62.4997	135.4370
110.000000 MHz	62.0802	124.0418
120.000000 MHz	61.7828	114.6928
130.000000 MHz	60.9614	106.6090
140.000000 MHz	60.6141	99.6422
150.000000 MHz	60.3110	93.8633
160.000000 MHz	59.8681	88.7289
170.000000 MHz	59.5694	84.3492
180.000000 MHz	59.4170	80.0673
190.000000 MHz	59.0601	76.3955
200.000000 MHz	58.7512	73.1625
210.000000 MHz	58.4880	70.3452
220.000000 MHz	58.1326	67.6924
230.000000 MHz	57.8125	65.2620
240.000000 MHz	57.4677	63.1540
250.000000 MHz	57.1974	61.1361

Test Report S/N:	021804-480Q9S
Test Date(s):	February 25, 2004
Test Type:	FCC/IC SAR Evaluation

## APPENDIX F - SAR TEST SETUP & DUT PHOTOGRAPHS

**FACE-HELD SAR TEST SETUP PHOTOGRAPHS**  
2.5 cm Separation Distance from Front of Radio to Planar Phantom

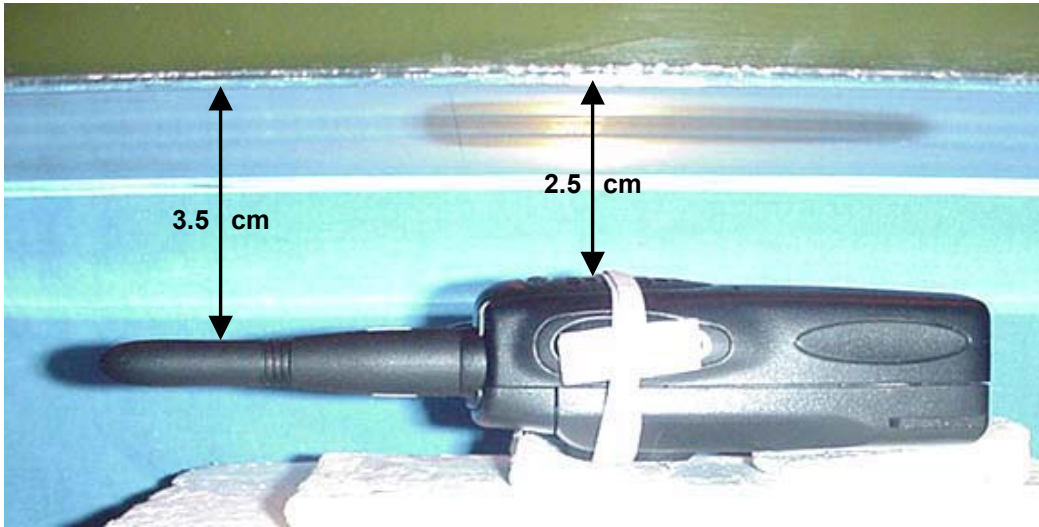

**BODY-WORN SAR TEST SETUP PHOTOGRAPHS**  
1.3 cm Belt-Clip Separation Distance to Planar Phantom  
with Speaker-Microphone Accessory (P/N: 420855202945)

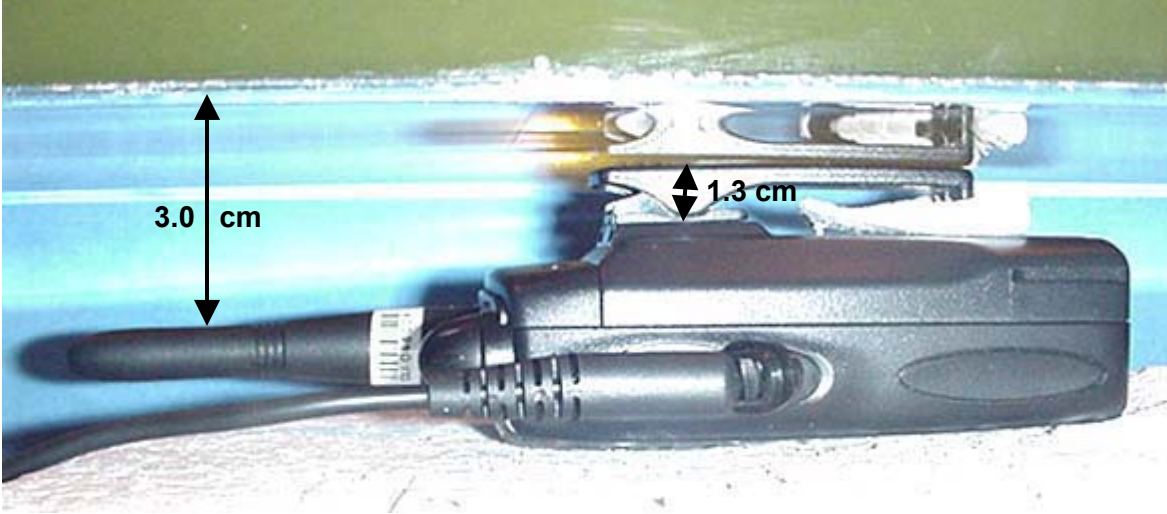



**BODY-WORN SAR TEST SETUP PHOTOGRAPHS**  
1.3 cm Belt-Clip Separation Distance to Planar Phantom  
with Ear-Bud Microphone Accessory (P/N: 420855203041)

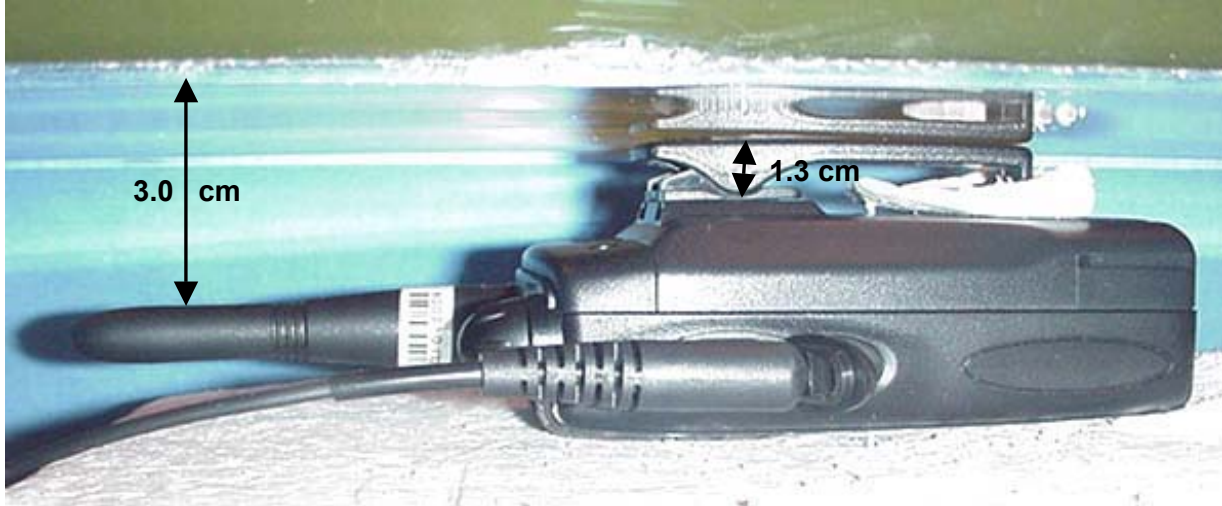

**BODY-WORN SAR TEST SETUP PHOTOGRAPHS**  
1.3 cm Belt-Clip Separation Distance to Planar Phantom  
with Ear-Loop Microphone Accessory (P/N: 420855203065)

