

---

## **Scope**

This manual is intended for use by service technicians familiar with similar types of equipment. It contains service information required for the equipment described and is current as of the printing date.

# **Product Safety and RF Exposure for Portable Two-Way Radios**

## **Compliance with RF Energy Exposure Standards**

**NOTICE: This radio is intended for use in occupational/controlled applications where users have been made aware of the potential for exposure and can exercise control over their exposure. This radio device is NOT authorized for general population, consumer or similar use.** BEFORE USING THIS RADIO, READ THE TRAINING MATERIAL BELOW WHICH CONTAINS IMPORTANT OPERATING INSTRUCTIONS FOR SAFE USAGE AND RF ENERGY AWARENESS AND CONTROL INFORMATION FOR COMPLIANCE WITH RF ENERGY EXPOSURE LIMITS IN APPLICABLE NATIONAL AND INTERNATIONAL STANDARDS.

### **Federal Communication Commission (FCC) Regulations**

The FCC has established limits for safe exposure to radio frequency (RF) emissions from portable two-way radios. The FCC requires manufacturers to demonstrate compliance with RF exposure limits before portable two-way radios can be marketed in the U.S. When two-way radios are approved for occupational/controlled environment exposure limits, the FCC requires users to be fully aware of, and exercise control over, their exposure. Awareness and control of RF exposure can be accomplished by the use of labels, or by education and training through appropriate means, such as information and instructions in user manuals or safety booklets. Your Advanced Wireless two-way radio has an RF exposure information label in the battery compartment. The training material below includes useful information about RF exposure and helpful instructions on how to control your RF exposure.

Your Advanced Wireless two-way radio is designed and tested to comply with a number of national and international standards and guidelines (listed below) regarding human exposure to RF electromagnetic energy. In terms of measuring RF energy for compliance with FCC exposure guidelines, your radio radiates measurable RF energy only while it is transmitting (during talking), not when it is receiving (listening) or in standby mode.

### **Compliance and Control Guidelines and Operating Instructions for Portable Two-Way Radios**

To control your exposure and ensure compliance with the occupational/controlled environment exposure limits, always adhere to the following procedures:

- \* Transmit no more than 50% of the time. To transmit (talk), push the Push-To-Talk (PTT) button. To receive calls, release the PTT button. Transmitting 50% of the time or less is important since the radio generates measurable RF energy exposure only when transmitting (in terms of measuring standards compliance).

- \* Hold the radio in a vertical position in front of the face with the microphone positioned at least one inch (2.5 cm) away from the lips. Keeping the radio at the proper distance is important since RF exposure decreases with increasing distance from the antenna.

- \* For body-worn operation, always use the radio with the AWC Belt-Clip Part No.: 420855203393. AWC-approved accessories, antennas, and device combinations have been tested and comply with the occupational/controlled environment RF exposure limits. The use of non-AWC approved accessories may result in exposure levels that may exceed the FCC's occupational/controlled environment RF exposure limits.

---

\* If you are not using a body-worn accessory and are not using the radio held in front of the face, ensure the radio is kept a minimum of 1.3 cm from the body when transmitting. Keeping the radio at a proper distance is important since RF exposure decreases with increasing distance from the antenna.

**FCC license Information**

Your Advanced Wireless Communications radio operates on communications frequencies which are subject to FCC (Federal Communications Commission) Rules & Regulations. FCC Rules require that all operators using Private Land Mobile radio frequencies obtain a radio license before operating their equipment. Application for license must be made on FCC form 601, and schedules D, E, and G.

**FAX:** Forms can be obtained by fax from the FCC Fax-On-Demand system. Call 1-202-418-0177 from your fax machine and request document number 000600 for the form, schedules, and instructions.

**MAIL:** Forms can be ordered by telephone, and will be sent to you by first class mail. Call the FCC Forms Hotline at 1-800-418-FORM (1-800-418-3676).

**INTERNET:** Form 601 and instructions can be downloaded from the FCC Forms website at:

<http://www.fcc.gov/Forms/Form601/601.html>

Before filling out your Form 601 application Technical Data section, you must decide which frequency (or frequencies) you will operate on. Refer to the frequency chart on page 26.

**Questions?** Call the FCC for license application questions at 1-888-CALL-FCC (1-888-225-5322).

If you have any questions, call Advanced Wireless Communications:

1-800-475-5852

**Notices to The User**

This device complies with Part 15 of the FCC Rules. Operation is subject to the following two conditions:

- (1) this device may not cause harmful interference, and
- (2) this device must accept any interference received, including interference that may cause undesired operation.

One or more of the following statements may be applicable:

<p style="text-align: center;"><b>FCC WARNING</b></p> <p>This equipment generates or uses radio frequency energy. Changes or modifications to this equipment may cause harmful interference unless the modifications are expressly approved in the instruction manual. The user could lose the authority to operate this equipment if an unauthorized change or modification is made.</p>
---

### **INFORMATION TO THE DIGITAL DEVICE USER REQUIRED BY THE FCC**

This equipment has been tested and found to comply with the limits for a Class B digital device, pursuant to Part 15 of the FCC Rules. These limits are designed to provide reasonable protection against harmful interference in a residential installation. This equipment generates, uses and can generate radio frequency energy and, if not installed and used in accordance with the instructions, may cause harmful interference to radio communications. However, there is no guarantee that the interference will not occur in a particular installation. If this equipment does cause harmful interference to radio or television reception, which can be determined by turning the equipment off and on, the user is encouraged to try to correct the interference by one or more of the following measures:

- Reorient or relocate the receiving antenna.
- Increase the separation between the equipment and receiver.
- Connect the equipment to an outlet on a circuit different from that to which the receiver is connected.
- Consult the dealer for technical assistance.

### **SAFETY INFORMATION:**

Your wireless portable two-way radio has been designed using a low power transmitter.

When the PTT switch is pressed, the radio generates radio frequency (RF) electromagnetic energy (EME). This radio is designed to comply with the FCC Report and Order FCC 96-326 (August, 1996).

## **User Safety Information**

### **PLEASE READ THIS IMPORTANT INFORMATION BEFORE USING YOUR Advanced Wireless Communications PORTABLE TWO-WAY RADIO.**

- Only qualified technicians are allowed to maintain this product.
- To avoid electromagnetic interference, turn off your radio in places where posted notices instruct you to do so. Hospitals or health care facilities may be using equipment that is sensitive to external RF energy. When travelling on aircraft, turn off your radio when the airline crew instructs you to do so.
- When in vehicles equipped with an air bag, do not place a portable radio in the airbag deployment area.
- Turn off your radio prior to entering any area with a potentially explosive atmosphere. Do not remove, install, or charge batteries in such areas.
- To avoid possible interference with blasting operations, turn off your radio when you are near electrical blasting caps.
- Do not use any portable radio that has a damaged antenna. If a damaged antenna comes into contact with your skin, a minor burn may result.
- Do not expose the radio to direct sunlight for long periods of time. Do not place the radio in direct contact with any heating source.

---

# Brief Introduction

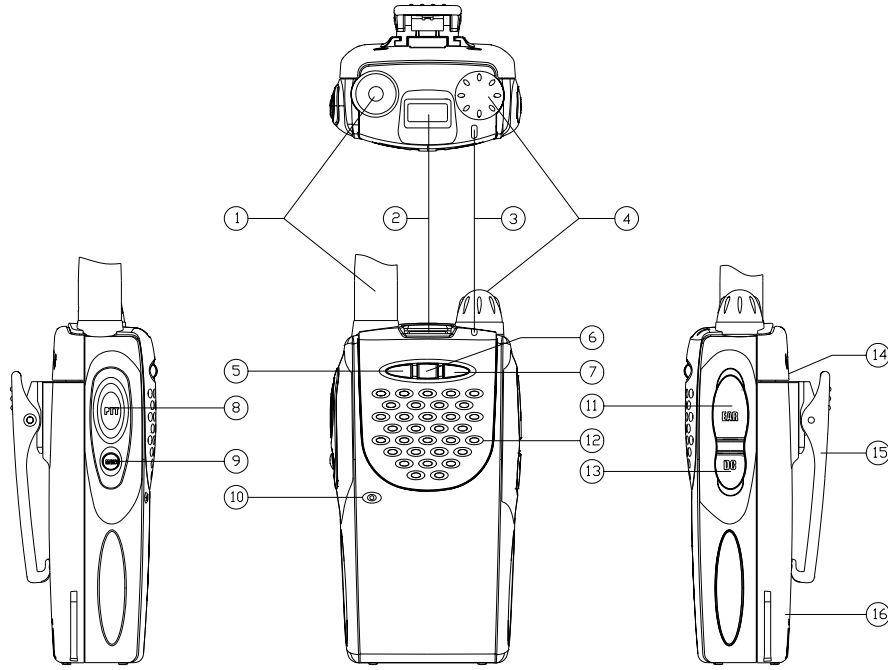

1. Antenna  
Used to receive or transmit signals.
2. LCD  
Displays operation status of the radio.
3. LED indicator  
In transmit mode, the red LED will turn on. In receive mode, the green LED will turn on. A flashing red LED indicates that the battery is low.
4. POWER/VOL Knob  
Rotate the volume control clockwise to turn the unit on, fully counter clockwise to turn the unit off. Increase or decrease volume by adjusting the volume control accordingly.
5. Down key  
Adjust the channel downwards.
6. SCAN key  
Press the scan key to activate the scan mode. When the radio detects properly coded activity on a channel, it will stop scanning and listen to that channel.
7. Up key  
Adjust the channel upwards.
8. PTT button  
To transmit, press and hold PTT button. To receive, release PTT button.

- 
9. MONI button  
In receive mode, press the MONI key to monitor activity on your selected channel.
  10. Microphone  
Input audio.
  11. Earpiece Jack/ PC programming port  
Used to connect external earphone/microphone accessories or used to connect with programming cable.
  12. Speaker  
Output audio.
  13. DC jack  
Used for factory adjustment only.
  14. Battery latch  
Used to fasten and remove the battery.
  15. Belt clip  
Used to clip radio on your belt.
  16. Battery pack

---

# LCD Display

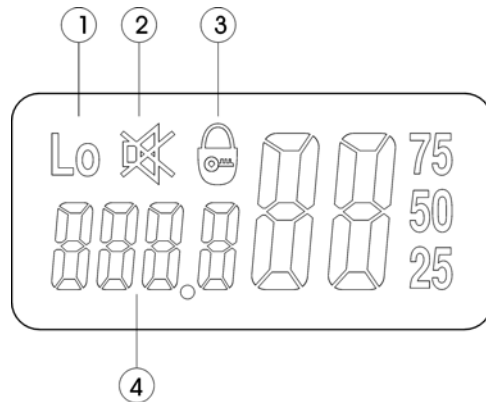

1. Appears when the transmit power of the current channel is set for low power.
2. Appears when the dealer disables the radio's speaker.
3. Appears when the keys are locked.
4. Display the current channel number.

---

# Dealer Operation Description

## Keys combination

Key	Function
MONI+SCAN	Key Lock/unlock (dealer can program it ON/OFF)
MONI+UP	Change CTCSS/CDCSS number (dealer can program it ON/OFF)
MONI+DOWN	Adjust squelch level 0-9(dealer can program it ON/OFF)
PTT+MONI	High/low power (dealer can program it ON/OFF)

## Dealer Mode

Turn on the radio while pressing [PTT] and [SCAN] simultaneously, in 3 seconds, the radio enters Password Check (if password has been set) or Dealer Menu.

### 1. Password Check

LCD displays “-----”. (The first “-”blinks, indicating to enter password.)

- (1) For detailed operations, see 4. Password Set.
- (2) Dealer Menu can be accessed only after entering correct password.

### 2. Dealer Menu

LCD displays “RESEtY”. (“y” or “n” blinks to indicate yes or no.) There are 9 options:

- (1) Reset enabled  
LCD displays “ RESEtY”. (“y” or “n” blinks to indicate yes or no.)
- (2) Tune mode enabled  
LCD displays tUNEy. (“y” or “n” blinks to indicate yes or no.)
- (3) Channel set enabled LCD displays CHSEtY. (“y” or “n” blinks to indicate yes or no.)
- (4) Function set enabled  
LCD displays FUNCy. (“y” or “n” blinks to indicate yes or no.)
- (5) Wired clone enabled  
LCD displays CLONEy. (“y” or “n” blinks to indicate yes or no.)
- (6) Radio speaker enabled  
LCD displays Sp y. (“y” or “n” blinks to indicate yes or no.)
- (7) Keys combination enabled  
LCD displays ASSIgy. (“y” or “n” blinks to indicate yes or no.)
- (8) Adjust Max. channel capability  
LCD displays CHNU 99. (99 blinks, indicating to enter new number).
- (9) Set new password  
LCD displays SECrEt.

Press [SCAN], LCD displays “-----”. The first “-”blinks. See 4. Password Set.

### 3. Dealer Menu Operations

- (1) Press [UP]/[DOWN] to change the digit in cursor.
- (2) Press [PTT] to save the change and enter the next menu option or next option setting.
- (3) Press [MONI] to directly enter the next menu option or next option setting.

### 4. Password Set



- 
- (1) Password contains 6 digits (0-9).
  - (2) After correct password is checked, a new password can be entered and original one can be cancelled.
  - (3) Press [SCAN] to enter password-entering mode.
  - (4) Press [UP]/[DOWN] to enter digits (0-9).
  - (5) Press [SCAN] to delete entered password or cancel password.  
Delete entered password: LCD displays“-----”. The first “-” blinks.  
Cancel password: LCD displays “CANCEL”. “CANCEL” blinks.
  - (6) Press [PTT] to confirm the entered.  
If password is less than 6 digits, enter other ones until there are 6 digits.  
After entering a 6-digit password, password is checked.  
After entering a 6-digit new password, new password is set.  
Cancel Password Check when LCD displays “CANCEL”.
  - (7) Press [MONI] to exit.  
If password is being checked, pressing [MONI] cannot exit password-entering mode.  
When entering a new password, press [MONI] to exit and enter reset option.

## Power On Menu

Turn on the radio while holding down [PTT] and [MONI] simultaneously, in 3 seconds, the following enabled options are displayed:

- (1) Tune mode.  
LCD displays “tUNE”.
- (2) Channel set  
LCD displays “ CHSEt”.
- (3) Function set  
LCD displays “ FUNSEt”.
- (4) Keys combination set  
LCD displays “ASSIgn”.

Operations: Press [UP]/[DOWN] to select the next menu option.

Press [PTT] to enter option setting.

**Note:** All menu options can be enabled or disabled by the dealer in dealer mode.

If one menu option is disabled by the dealer, then this option is skipped; if all options are set invalid, the radio directly enters user mode.

## Channel set

1. Select “CHSEt” in Power On Menu. The radio enters channel set mode. Now LCD displays channel number as follows:

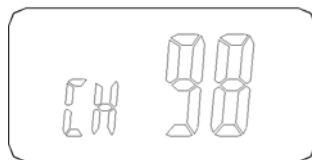

---

Press [UP]/[DOWN] to select the channel which needs to be programmed. Press [MONI] to return to Power On Menu.

2. Press [PTT], LCD displays the receive frequency of current channel as follows:

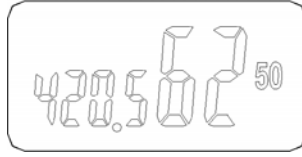

Press [SCAN] to toggle LCD display between frequency and blank, as follows:



Frequency change operations:

Press [UP] or [DOWN] to change frequency upwards or downwards. (In step of 5 KHz or 6.25KHz)

Hold down [UP] or [DOWN] to continuously change frequency.

Press [MONI] to toggle step between 1MHz(now the left third digit blinks), 100KHz(now the left forth digit blinks) and normal step (5 KHz or 6.25KHz).

Holding down [MONI] exceeds 1 second, the step will be toggled between 5KHz and 6.25KHz.

Press [UP] or [DOWN] to change the frequency in corresponding step increments.

Hold down [UP]/[DOWN] to continuously change frequency.

3. Press [PTT], LCD displays receive CTCSS/CDCSS number of current channel:

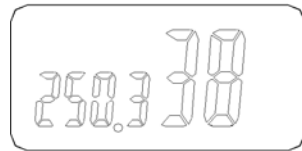

The right two digits display CTCSS/CDCSS number, and the left 4 digits display CTCSS frequency or CDCSS code.

Press [UP] or [DOWN] to change CTCSS/CDCSS number upwards or downwards.

Hold down [UP]/[DOWN] to continuously change CTCSS/CDCSS number.

Press [SCAN] to toggle LCD display between OFF, CTCSS, CDCSS and reverse CDCSS, as follows:

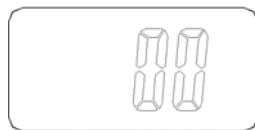

(1) OFF



(2) CTCSS

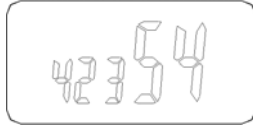

(3) CDCSS

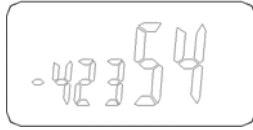

(4) Reverse CDCSS

4. Press [PTT], LCD displays transmit frequency of current channel as follows:

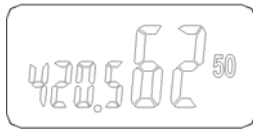

The setting operations are same as those of receive frequency.

5. Press [PTT], LCD displays transmit CTCSS/CDCSS number:

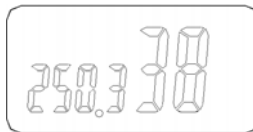

The setting operations are same as those of receive CTCSS/CDCSS.

### CTCSS/CDCSS

CTCSS					
NO.	Freq (Hz)	NO.	Freq (Hz)	NO.	Freq (Hz)
00	NO TONE	13	103.5	26	162.2
01	67.0	14	107.2	27	167.9
02	71.9	15	110.9	28	173.8
03	74.4	16	114.8	29	179.9
04	77.0	17	118.8	30	186.2
05	79.7	18	123.0	31	192.8
06	82.5	19	127.3	32	203.5
07	85.4	20	131.8	33	210.7
08	88.5	21	136.5	34	218.1
09	91.5	22	141.3	35	225.7
10	94.8	23	146.2	36	233.6
11	97.4	24	151.4	37	241.8
12	100.0	25	156.7	38	250.3

CDCSS					
NO.	CODE	NO.	CODE	NO.	CODE
01	023	29	174	57	445
02	025	30	205	58	464
03	026	31	223	59	465
04	031	32	226	60	466
05	032	33	243	61	503
06	043	34	244	62	506
07	047	35	245	63	516
08	051	36	251	64	532
09	054	37	261	65	546
10	065	38	263	66	565
11	071	39	265	67	606
12	072	40	271	68	612
13	073	41	306	69	624
14	074	42	311	70	627
15	114	43	315	71	631
16	115	44	331	72	632
17	116	45	343	73	654
18	125	46	346	74	662
19	131	47	351	75	664
20	132	48	364	76	703
21	134	49	365	77	712
22	143	50	371	78	723
23	152	51	411	79	731
24	155	52	412	80	732
25	156	53	413	81	734
26	162	54	423	82	743
27	165	55	431	83	754
28	172	56	432		

6. Press [PTT], LCD displays “Add”/ “DEL”. Press [UP]/[DOWN] to add /delete the channel to/from scan list. LCD displays as follows:

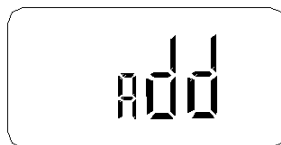

(1) Add: add the channel in scan list.



- (2) dEL: delete the channel from scan list, and the channel (except priority channel) will not be scanned.
7. Press [PTT], LCD displays “HI”/“LO”. Press [UP]/[DOWN] to toggle RF power between high and low. LCD displays as follows:



8. Press [PTT], LCD displays “BSy On”/“BSyOFF”. Press [UP]/[DOWN] to toggle Busy Channel Lockout between ON and OFF.
9. Press [PTT] to save settings. Press [PTT] again to enter the next channel and continue the settings. When settings are completed, turn off power to exit.

## Model set and reset

Short out the two SELF points on PCB, and turn on the power. After a “beep” sounds, (red LED glows at the same time), LCD displays all signs. And then the two SELF points is released, the radio enters model set and reset mode, LCD displays BAND 1-22 and red LED goes out.

- Press [up]/[down] to select model number 1-22. (Data of initialization is as the following table)
  
- Press [PTT] to confirm selected model and then reset.

Model	Freq. (MHz)	IF. (MHz)	1CH(C)		2CH(L)		3CH(H)		4CH	5CH	6CH	7CH	8CH	9-99CH
			Tx (MHz)	Rx (MHz)	Tx (MHz)	Rx (MHz)	Tx (MHz)	Rx (MHz)	(MHz)	(MHz)	(MHz)	(MHz)	(MHz)	(MHz)
1	150.000~173.995	+45.05	162.000	162.100	150.000	150.100	173.975	173.900	162.500	162.550	162.600	162.550	162.650	
2	136.000~149.995	+45.05	143.000	143.100	136.000	136.100	149.975	149.900	143.500	143.550	143.600	143.550	143.650	
3	146.000~173.995	+45.05	160.000	160.100	146.000	146.100	173.975	173.900	160.500	160.550	160.600	160.550	160.650	
4	144.000~147.995	+45.05	146.000	146.100	144.000	144.100	147.975	147.900	146.500	146.550	146.600	146.550	146.650	
5	136.000~147.995	+45.05	142.000	142.100	136.000	136.100	147.975	147.900	142.500	142.550	142.600	142.550	142.650	
6	136.000~173.995	+45.05	155.000	155.100	136.000	136.100	173.975	173.900	155.500	155.550	155.600	155.550	155.650	
7	450.000~469.995	-45.05	460.000	460.100	450.000	450.100	469.975	469.900	460.300	460.350	460.400	460.350	460.450	
8	400.000~419.995	-45.05	410.000	410.100	400.000	400.100	419.975	419.900	410.500	410.550	410.600	410.550	410.650	
9	470.000~489.995	-45.05	480.000	480.100	470.000	470.100	489.975	489.900	480.500	480.550	480.600	480.550	480.650	
10	490.000~511.995	-45.05	501.000	501.100	490.000	490.100	511.975	511.900	501.500	501.550	501.600	501.550	501.650	
11	220.000~239.995	-45.05	230.000	230.100	220.000	220.100	239.975	239.900	230.500	230.550	230.600	230.550	230.650	
12	240.000~259.995	-45.05	250.000	250.100	240.000	240.100	259.975	259.900	250.500	250.550	250.600	250.550	250.650	
13	336.000~367.995	-45.05	352.000	352.100	336.000	336.100	367.975	367.900	352.500	352.550	352.600	352.550	352.650	
14	368.000~395.995	-45.05	382.000	382.100	368.000	368.100	395.975	395.900	382.500	382.550	382.600	382.550	382.650	
15	370.000~389.995	-45.05	380.000	380.100	370.000	370.100	389.975	389.900	380.500	380.550	380.600	380.550	380.650	
16	350.000~369.995	-45.05	360.000	360.100	350.000	350.100	369.975	369.900	360.500	360.550	360.600	360.550	360.650	
17	406.000~429.995	-45.05	418.000	418.100	406.000	406.100	429.975	429.900	418.500	418.550	418.600	418.550	418.650	
18	400.000~429.995	-45.05	415.000	415.100	400.000	400.100	429.975	429.900	415.500	415.550	415.600	415.550	415.650	
19	430.000~439.995	-45.05	435.000	435.100	430.000	430.100	439.975	439.900	435.500	435.550	435.600	435.550	435.650	
20	438.000~449.995	-45.05	444.000	444.100	438.000	438.100	449.975	449.900	444.500	444.550	444.600	444.550	444.650	
21	440.000~469.995	-45.05	455.000	455.100	440.000	440.100	469.975	469.900	455.500	455.550	455.600	455.550	455.650	
22	480.000~519.995	-45.05	500.000	500.100	480.000	480.100	519.975	519.900	500.500	500.550	500.600	500.550	500.650	
CH QT/DQT			OFF	OFF	OFF	OFF	OFF	OFF	OFF	023	023	127.3	151.4	

## Function set

Select “FUNSET” in Power On Menu. The radio enters function set mode.

Setting No. (PTT)	Function name	Settings (Defaults are underlined)	Display ([UP]/[DOWN])	Specifications
1	Monitor	OFF	OFF	Monitor function is OFF
		Monitor	1	Hold down [MONI] to cut off signaling temporarily.
		Momentary		
		Monitor Lock	2	Press [MONI] to cut off signaling. Switches each time [MONI] is pressed.
		<u>SQ OFF</u>	3	Hold down [MONI] to open squelch.
		<u>Momentary</u>		
2	Scan	<u>Carrier operated</u>	CO	
		Time operated	TO	
3	Dropout Time	0.5-5s <u>5s</u>	0.5-5 5	Time until scan restarts when it's stopped by transmission. Step: 0.5s
4	Priority setting	<u>OFF</u>	OFF	No priority channel
		Fixed	1	Fixed priority channel
		Selectable	2	Selectable priority channel
5	Priority channel	1-N (2-99) <u>1</u>	1-N	Valid only when the fixed priority channel is set.
6	Look Back	0.5-5s (Step: 0.5s) <u>1.5s</u>	0.5-5.0	The period priority channel is checked while scan stops at a non-priority channel during priority scan.
7	Revert channel select	<u>Last call</u>	1	Last channel at pause in scan. Channel where scan is stopped. Channel at start of scan when scan not stopped at all.
		Last used	2	Last channel transmitted during scan. Channel where scan is stopped. Channel at start of scan when scan not stopped at all.
		Scan start	3	Channel where scan started during scan. Channel where scan is stopped.
		Priority	4	Priority channel during scan. Channel where scan is stopped.
8	Squelch level	0-9 <u>5</u>	0-9 <u>5</u>	

Setting No. (PTT)	Function name	Settings (Defaults are underlined)	Display ([UP]/[DOWN])	Specifications
9	Time Out timer (TOT)	0 1-10 <u>6</u>	OFF 30-300 180	OFF: 10 minutes (Step: 30s)
10	Beep	<u>ON</u>	ON	ON: Beep is on.
		OFF	OFF	OFF: Beep is off.
11	Backlight	<u>ON</u>	ON	ON □ Backlight is enabled.
		OFF	OFF	OFF: backlight is disabled.
12	Wideband/Narrowband	<u>Wideband</u>	25	25 □ 25.0KHz
		Narrowband	1250	1250: 12.5KHz
13	Battery save	<u>ON</u>	ON	
		OFF	OFF	

### Wired clone

First enable Wired Clone Mode in dealer mode. (Refer to “Dealer Mode” in page 5).

Turn on the radio while holding down [MONI], in 2 seconds, LCD displays “clone”; Release [MONI], the radio enters wired clone mode.

- (1) Press PTT to enable/disable Wired Clone Mode of the cloned radio. The Wired Clone Mode settings of the original radio will not be changed.

Pressing PTT button, the green LED flashes two times with a beep to enable Wired Clone Mode; the red LED flashes two times with two beeps to disable.

Entering Wired Clone Mode, the default is disabling the Wired Clone Mode of the cloned radio.

- (2) Press [MONI], LCD displays “-C-“, clone begins and “c” blinks at the same time; after clone completes, blink stops, and LCD displays “-c-End”.

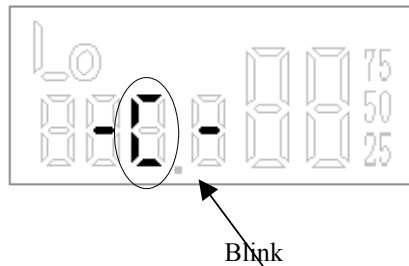



---

## PC programming

Connect a PC and a radio with a programming cable, and then program the radio by the PC.

- 1). Write data into the radio, green LED glows; read data from the radio, red LED glows.  
During programming, LCD displays as cloning, “c” blinking. When programming is complete, blink stops and LCD displays“-c-End”.
- 2). When PC tune mode begins, LCD displays “tune”. There are the following options in the tune mode:
  - . Low battery alert level  
LCD displays “ tuneb”.
  - . SQL9  
LCD displays “ tune9”(center frequency)
  - . SQL3  
LCD displays “tune3” (center frequency)
  - . CTCSS deviation (Wide)  
LCD displays“tune1”(center frequency)
  - .CTCSS deviation (Narrow)  
LCD displays“ tune2” (center frequency)
  - .CDCSS deviation (Wide)  
LCD displays“ tune5” (center frequency)
  - .CDCSS deviation (Narrow)  
LCD displays“ tune6” (center frequency)

During PC tuning, the last character on LCD is displayed and blinks.

## Tune mode

Select “tunE” in Power On Menu. The radio enters tune mode.

There are following options in tune mode:

- . Low battery alert level  
LCD displays “BAtREF”.
  - . SQL9  
LCD displays “ sql 9” (center frequency)
  - . SQL3  
LCD displays “sql 3” (center frequency)
  - . CTCSS deviation (Wide)  
LCD displays “CtCSS”(center frequency)
  - . CTCSS deviation (Narrow)  
LCD displays“ CtCSSn” (center frequency)
  - . CDCSS deviation (Wide)  
LCD displays“ CdCSS” (center frequency)
  - . CDCSS deviation (Narrow)  
LCD displays “CdCSSn” (center frequency)
  - . Center Frequency check  
LCD displays “SENS C” ([PTT]: R/T, SCAN, wide/narrow)
  - . Low Frequency Check  
LCD displays “SENS L” ([PTT]: R/T, SCAN, wide/narrow)
- (10). High Frequency Check

---

LCD displays “SENS H” ([PTT]: R/T, SCAN, wide/narrow)

(11). Center Frequency with CTCSS 250.3 check

LCD displays “SENC 38” ([PTT]: R/T, SCAN, wide/narrow)

Operations: Press [UP]/[DOWN] to select the next menu option.

Press [PTT] to enter option settings:

In [1]-[7] options, LCD displays blinking digits. Now press [UP]/[DOWN] to adjust, press [MONI] to exit.

In [8]-[11] options, C/L/H blinks, indicating center frequency, low frequency or high frequency. If wideband, “F” is displayed; if narrowband, “Fn” is displayed.

Now press [MONI] to exit; press [SCAN] to switch the band between wide and narrow. Press [UP]/[DOWN] to change power between high and low.

**Note:** Center, low and high frequency can be changed by PC programming software.

### **Keys combination set**

Select “ASSIgn” in Power On menu. The radio will enter keys combination set mode.

1. Set [MONI]+[UP] valid/invalid. LCD displays UP on/oFF.
2. Set [MONI]+[Down] valid/invalid. LCD displays dn on/oFF.
3. Set [MONI]+[SCAN] valid/invalid. LCD displays SCN on/oFF.
4. Set [MONI]+[PTT] valid/invalid. LCD displays Ptt on/oFF.

Above keys combinations are valid only in user mode.

Operations:

Press [UP]/[DOWN] to toggle the keys combination between on and off.

Press [PTT] to save the setting and enter the next option setting.

Press [MONI] to exit the mode and return to “ASSIgn” option in Power On Menu.