

PAGE NO.

NAME OF TEST: Carrier Output Power (Conducted)

SPECIFICATION: 47 CFR 2.1046 (a)

GUIDE: ANSI/TIA/EIA-603-1992, Paragraph 2.2.1

TEST EQUIPMENT: As per attached page

MEASUREMENT PROCEDURE

1. The EUT was connected to a resistive coaxial attenuator of normal load impedance, and the unmodulated output power was measured by means of an R. F. Power Meter.
2. Measurement accuracy is $\pm 3\%$.

MEASUREMENT RESULTS

(Worst case)

FREQUENCY OF CARRIER, MHz = 29.750, 34.050, 37.975

<u>POWER SETTING</u>	<u>R. F. POWER, WATTS</u>
Low	1
High	5

SUPERVISED BY:

TRANSMITTER POWER CONDUCTED MESUREMENTS

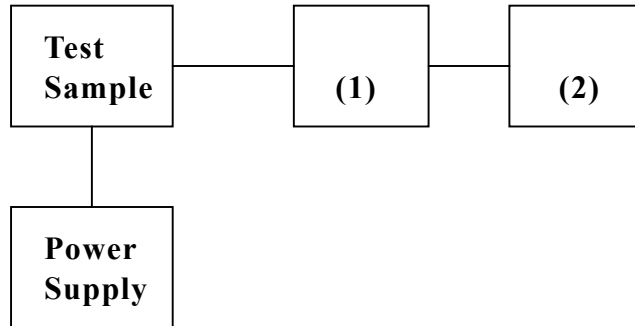

	Assent Description (as applicable)	S/N
(1)	<u>COAXIAL ATTENUATOR</u> 8481B POWER SENSOR	2702A06089
(2)	<u>POWER METERS</u> HP437B	3003U02196

PAGE NO.

NAME OF TEST: Unwanted Emission (Transmitter Conducted)

SPECIFICATION: 47 CFR 2.1051

GUIDE: ANSI/TIA/EIA-603-1992, Paragraph 2.2.13

TEST EQUIPMENT: As per attached page

MEASUREMENT PROCEDURE

1. The emission were measured for the worst case as follows:
(a): within a band of frequencies defined by the carrier frequency plus and minus one channels.
(b): from the lowest frequency generated in the EUT and to at least the 10th harmonic of the carrier frequency, or 40GHz, whichever is lower.
2. The magnitude of spurious emissions that are attenuated more than 10dB below the permissible value need not be specified.

3. MEASUREMENT RESULTS: ATTACHED FOR WORST CASE

FREQUENCY OF CARRIER, MHz = 29.975, 34.05, 37.975

SPECTRUM SEARCHED, GHz =0 to 10 x Fc

ALL OTHER EMISSIONS =10dB BELOW LIMIT

LIMIT(S), dBc

$-(50+10 \times \text{LOG } P) = -50.0$ (1 Watt)

$-(50+10 \times \text{LOG } P) = -57.0$ (5 Watt)

SUPERVISED BY:

PAGE NO.

TRANSMITTER SPURIOUS EMISSION

TEST A. OCCUPIED BANDWIDTH (IN-BAND SPURIOUS)

TEST B. OUT-OF-BAND SPURIOUS

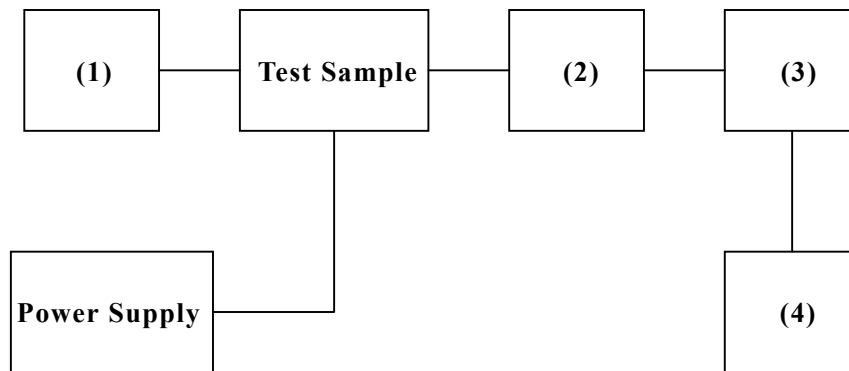

Asset Description
(as applicable)

(1) <u>AUDIO ANALYZER</u> HP8903B	s/n 2948A07690
(2) <u>COAXIAL ATTENUATOR</u> CFA-50NJJ-30 (30dB)	0L1343
(3) <u>FILTERS; HPF</u> MP526D	M63919
(4) <u>SPECTRUM ANALYZER</u> HP4396B	JP1KE00528

PAGE NO.

NAME OF TEST: Audio Low Pass Filter (Voice Input)

SPECIFICATION: 47 CFR 2.1047(a)

GUIDE: ANSI/TIA/EIA-603-1992, Paragraph 2.2.15

TEST EQUIPMENT: As per attached page

MEASUREMENT PROCEDURE

1. The EUT and test equipment were set up such that the audio input was connected at the input to the modulation limiter, and the modulated stage.
2. The audio output was connected at the output to the modulated stage.
3. **MESUREMENT RESULTS:**

PAGE NO.

TRANSMITTER TEST SET-UP

- TEST A. MODULATION CAPABILITY/DISTORTION
- TEST B. AUDIO FREQUENCY RESPONSE
- TEST C. HUM AND NOISE LEVEL
- TEST D. RESPONSE OF LOW PASS FILTER
- TEST E. MODULATION LIMITING

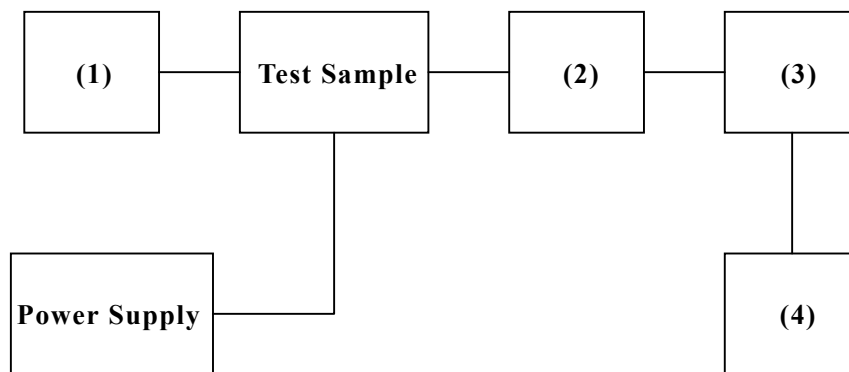

Asset Description
(as applicable)

(1) <u>AUDIO ANALYZER</u> HP8903B	s/n 2948A07690
(2) <u>COAXIAL ATTENUATOR</u> CFA-50NJJ-30 (30dB)	0L1343
(3) <u>MODULATION ANALYZER</u> HP8901B	3005A02524
(4) <u>AUDIO ANALYZER</u> HP8903B	2948A07690

PAGE NO.

NAME OF TEST: Audio Frequency Response

SPECIFICATION: 47 CFR 2.1047(a)

GUIDE: ANSI/TIA/EIA-603-1992, Paragraph 2.2.6

TEST EQUIPMENT: As per attached page

MEASUREMENT PROCEDURE

1. The EUT and test equipment were set up as shown on the following page.
2. The audio signal generator was connected to the audio input circuit/microphone of the EUT.
3. The audio signal input was adjusted to obtain 20% modulation at 1 KHz, and this point was taken as the 0 dB reference level.
4. With input levels held constant and below limiting at all frequency, the audio signal generator was varied from 100 Hz to 50 KHz.
5. The response in dB relative to 1 KHz was then measured, using the HP 8901B Modulation Analyzer.
6. MEASUREMEN RESULTS:

PAGE NO.

NAME OF TEST: Modulation Limiting

SPECIFICATION: 47 CFR 2.1047(b)

GUIDE: ANSI/TIA/EIA-603-1992, Paragraph 2.2.3

TEST EQUIPMENT: As per attached page

MEASUREMENT PROCEDURE

1. The signal generator was connected to the input of the EUT as for "Frequency Response of the Modulating Circuit."
2. The modulation response was measured for each of three frequency (one of which was the frequency of maximum response), and the input voltage was varied and was observed on an HP 8901B Modulation Analyzer.
3. The input level was varied from 30% modulation (± 1.5 KHz deviation) to at least 20 dB higher than the saturation point.
4. Measurements were performed for both negative and positive modulation and the respective results were recorded.
5. MEASUREMENT RESULTS: