

# RF MEASUREMENT REPORT

---

**FCC ID:** Q9DASIN0306

**Applicant:** Hewlett Packard Enterprise

**Product:** HPE Aruba User Experience Sensor

**Model No.:** ASIN0306

**Trademark:**  , 

**FCC Classification:** Unlicensed National Information Infrastructure (NII)

**FCC Rule Part(s):** Part 15 Subpart E (Section 15.407)

**Result:** Complies

**Received Date:** 2023-06-15

**Test Date:** 2023-07-03 ~ 2023-08-13

**Reviewed By:**

\_\_\_\_\_  
Jame Yuan

**Approved By:**

\_\_\_\_\_  
Robin Wu



The test results relate only to the samples tested.  
This equipment has been shown to be capable of compliance with the applicable technical standards as indicated in the measurement report and was tested in accordance with the measurement procedures specified in KDB789033 and KDB 291074. Test results reported herein relate only to the item(s) tested.  
The test report shall not be reproduced except in full without the written approval of MRT Technology (Suzhou) Co., Ltd.

### Revision History

Report No.	Version	Description	Issue Date	Note
2306RSU027-U5	V01	Initial Report	2023-09-22	Invalid
2306RSU027-U5	V02	Add 1-18GHz test plot of RSE	2023-10-30	Valid

## CONTENTS

Description	Page
<b>1. General Information .....</b>	<b>6</b>
1.1. Applicant .....	6
1.2. Manufacturer .....	6
1.3. Testing Facility .....	6
1.4. Product Information.....	7
1.5. Radio Specification under Test .....	8
1.6. Working Frequencies .....	8
1.7. Antenna Details.....	9
<b>2. Test Configuration .....</b>	<b>10</b>
2.1. Test Mode.....	10
2.2. Test System Connection Diagram.....	11
2.3. Test Software .....	11
2.4. Applied Standards.....	12
2.5. Test Environment Condition .....	12
<b>3. Antenna Requirements .....</b>	<b>13</b>
<b>4. Measuring Instrument .....</b>	<b>14</b>
<b>5. Decision Rules and Measurement Uncertainty .....</b>	<b>16</b>
5.1. Decision Rules .....	16
5.2. Measurement Uncertainty .....	16
<b>6. Test Result.....</b>	<b>17</b>
6.1. Summary.....	17
6.2. 26dB & 99% Bandwidth Measurement .....	18
6.2.1. Test Limit .....	18
6.2.2. Test Procedure .....	18
6.2.3. Test Setting .....	18
6.2.4. Test Setup .....	18
6.2.5. Test Result .....	19
6.3. 6dB Bandwidth Measurement.....	20
6.3.1. Test Limit .....	20
6.3.2. Test Procedure .....	20
6.3.3. Test Setting .....	20
6.3.4. Test Setup .....	20
6.3.5. Test Result .....	20
6.4. Output Power Measurement .....	21
6.4.1. Test Limit .....	21

6.4.2.	Test Procedure .....	21
6.4.3.	Test Setting .....	21
6.4.4.	Test Setup .....	21
6.4.5.	Test Result .....	21
6.5.	Power Spectral Density Measurement .....	22
6.5.1.	Test Limit .....	22
6.5.2.	Test Procedure .....	22
6.5.3.	Test Setting .....	22
6.5.4.	Test Setup .....	22
6.5.5.	Test Result .....	22
6.6.	Frequency Stability Measurement .....	23
6.6.1.	Test Limit .....	23
6.6.2.	Test Procedure .....	23
6.6.3.	Test Setup .....	23
6.6.4.	Test Result .....	24
6.7.	Radiated Spurious Emission Measurement.....	25
6.7.1.	Test Limit .....	25
6.7.2.	Test Procedure .....	25
6.7.3.	Test Setting .....	25
6.7.4.	Test Setup .....	27
6.7.5.	Test Result .....	28
6.8.	Radiated Restricted Band Edge Measurement .....	29
6.8.1.	Test Limit .....	29
6.8.2.	Test Procedure .....	31
6.8.3.	Test Setting .....	31
6.8.4.	Test Setup .....	32
6.8.5.	Test Result .....	32
6.9.	AC Conducted Emissions Measurement .....	33
6.9.1.	Test Limit .....	33
6.9.2.	Test Setup .....	33
6.9.3.	Test Result .....	33
<b>Appendix A - Test Result.....</b>		<b>34</b>
A.1	Duty Cycle Test Result .....	34
A.2	26dB & 99% Bandwidth Test Result .....	36
A.3	6dB Bandwidth Test Result .....	42
A.4	Output Power Test Result .....	48
A.5	Power Spectral Density Test Result.....	49
A.6	Frequency Stability Test Result.....	60
A.7	Radiated Spurious Emission Test Result.....	61

A.8	Radiated Restricted Band Edge Test Result.....	86
A.9	AC Conducted Emissions Test Result .....	134
<b>Appendix B - Test Setup Photograph .....</b>		<b>136</b>
<b>Appendix C - EUT Photograph .....</b>		<b>137</b>



#### 1.4. Product Information

Product Name	HPE Aruba User Experience Sensor
Model No.	ASIN0306
Serial No.	CNQGLPM00G
Software Version	6.5GA
Wi-Fi Specification	802.11a/b/g/n/ac/ax
Bluetooth Specification	BLE only
ZigBee Specification	802.15.4
Power Type	AC/DC Adapter Input
Operating Temperature	0 ~ 40 °C
Operating Environment	Indoor Use
Integrated Modular Information	
Specification	Model Number: EG21-G FCC ID: XMR201906EG21G GSM 850, PCS 1900 Supported UTRA Band: 2, 4, 5 Supported E-UTRA Band: FDD Band: 2, 4, 5, 7, 12, 13, 25, 26 TDD Band: 38, 41 GNSS: GPS, BDS, GLONASS, Galileo
Accessories	
AC/DC Adapter	Model No.: WB-12G12R Input: 100-240V, 50/60Hz, 0.3A Max Output: 12.0V=1.0A 12.0W
Note: The information of EUT was provided by the manufacturer, and the accuracy of the information shall be the responsibility of the manufacturer.	

### 1.5. Radio Specification under Test

Frequency Range	For 802.11a/n-HT20/ac-VHT20/ax-HE20: 5845MHz, 5865MHz, 5885MHz  For 802.11n-HT40/ac-VHT40/ax-HE40: 5835MHz, 5875MHz  For 802.11ac-VHT80/ax-HE80: 5855MHz	
Type of Modulation	802.11a/n/ac: OFDM 802.11ax: OFDMA	
Data Rate	802.11a: 6/9/12/18/24/36/48/54Mbps 802.11n: up to 300Mbps 802.11ac: up to 866.6Mbps 802.11ax: up to 1201Mbps	
Channel Puncturing Function	<input type="checkbox"/> Supported	<input checked="" type="checkbox"/> Unsupported
Support RU	<input checked="" type="checkbox"/> Full RU	<input type="checkbox"/> Partial RU

### 1.6. Working Frequencies

#### 802.11a/n-HT20/ac-VHT20/ax-HE20

Channel	Frequency	Channel	Frequency	Channel	Frequency
169	5845 MHz	173	5865 MHz	177	5885 MHz

#### 802.11n-HT40/ac-VHT40/ax-HE40

Channel	Frequency	Channel	Frequency	Channel	Frequency
167	5835 MHz	175	5875 MHz	--	--

#### 802.11ac-VHT80/ax-HE80

Channel	Frequency	Channel	Frequency	Channel	Frequency
171	5855 MHz	--	--	--	--



**1.7. Antenna Details**

Antenna Type	Frequency Band (MHz)	Tx Paths	Directional Gain (dBi)		Beamforming Gain (dBi)
			Uncorrelated	Correlated	
<b>Wi-Fi Antennas (Radio 0)</b>					
PIFA Antenna	2400 ~ 2483.5	2	2.1	5.0	5.0
	5150 ~ 5250	2	3.5	6.5	6.5
	5250 ~ 5350	2	3.5	6.5	6.5
	5470 ~ 5725	2	3.5	6.3	6.3
	5725 ~ 5850	2	3.5	6.0	6.0
	5850 ~ 5895	2	3.6	6.2	6.2
<b>Wi-Fi Antennas (Radio 1)</b>					
PIFA Antenna	2400 ~ 2483.5	2	2.0	4.8	4.8
	5925 ~ 6425	2	2.7	5.5	5.5
	6425 ~ 6525	2	3.1	6.0	6.0
	6525 ~ 6875	2	3.1	6.0	6.0
	6875 ~ 7125	2	3.2	6.1	6.1
<b>Bluetooth / ZigBee Antenna</b>					
PIFA Antenna	2400 ~ 2483.5	1	2.3	--	--
<p>Note:</p> <p>1, The EUT supports Cyclic Delay Diversity (CDD) mode, and CDD signals are correlated.</p> <p>2, The EUT also supports Beam Forming mode, and the Beam Forming support 802.11n/ac/ax, not include 802.11a/b/g.</p> <p>3, The antenna gain is from antenna report that was provided by the applicant.</p>					

## 2. Test Configuration

### 2.1. Test Mode

Mode 1: Transmit by 802.11a (6Mbps)
Mode 2: Transmit by 802.11ac-VHT20 (MCS0) _N <sub>SS</sub> =1 (MIMO Mode)
Mode 3: Transmit by 802.11ac-VHT40 (MCS0) _N <sub>SS</sub> =1 (MIMO Mode)
Mode 4: Transmit by 802.11ac-VHT80 (MCS0) _N <sub>SS</sub> =1 (MIMO Mode)
Mode 5: Transmit by 802.11ax-HE20 (MCS0) _N <sub>SS</sub> =1 (MIMO Mode)
Mode 6: Transmit by 802.11ax-HE40 (MCS0) _N <sub>SS</sub> =1 (MIMO Mode)
Mode 7: Transmit by 802.11ax-HE80 (MCS0) _N <sub>SS</sub> =1 (MIMO Mode)
Note 1: All modes of operation and data rates were investigated, so all RF test requirements shall be executed at the worst data rate.
Note 2: For beamforming operation, manufacturer automatically backs power down based on a $10\log(N_{ANT})$ factor based on CDD power. Therefore, only the CDD mode was evaluated in this report.
Note 3: 802.11n and 802.11ac have same modulation type and same power value, so we only show 802.11ac test data in report.

#### Radio Working Mode

Work Groups	Wi-Fi Radio 0	Wi-Fi Radio 1	IOT
1	2.4G	6G	BLE or ZigBee
2	5G	2.4G	BLE or ZigBee
3	5G	6G	BLE or ZigBee

## 2.2. Test System Connection Diagram

The device was tested per the guidance ANSI C63.10: 2013 was used to reference the appropriate EUT setup for radiated emissions testing and AC line conducted testing.

Connection Diagram – Radiated Emission testing & AC Conducted Emissions

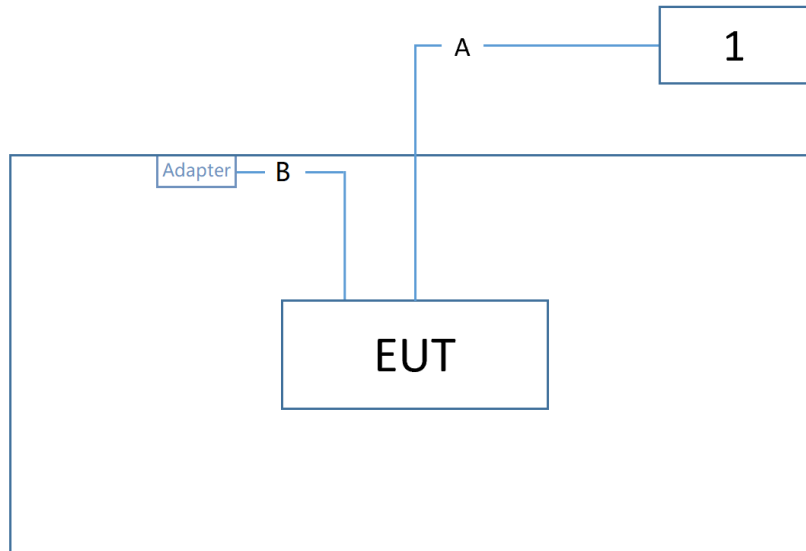

Cable Type		Cable Description	
A	Ethernet Cable	Non shielded, > 10m	
B	Power Cable	Non shielded, 1.6m	
Product		Manufacturer	Model No.
1	Notebook	Dell	Latitude 5491

## 2.3. Test Software

The test utility software used during testing was “accessMTool”, and the version was 3.2.1.5.

#### 2.4. Applied Standards

According to the specifications of the manufacturer, the EUT must comply with the requirements of the following standards:

- FCC Part 15.407
- KDB 789033 D02v02r01
- KDB 291074 D02v01
- KDB 662911 D01v02r01
- ANSI C63.10-2013

#### 2.5. Test Environment Condition

Ambient Temperature	15 ~ 35°C
Relative Humidity	20 ~ 75%RH

### 3. Antenna Requirements

**Excerpt from §15.203 of the FCC Rules/Regulations:**

“An intentional radiator antenna shall be designed to ensure that no antenna other than that furnished by the responsible party can be used with the device. The use of a permanently attached antenna or of an antenna that uses a unique coupling to the intentional radiator shall be considered sufficient to comply with the provisions of this section.”

- The antenna of the device is **permanently attached**.
- There are no provisions for connection to an external antenna.

**Conclusion:**

The unit complies with the requirement of §15.203.

#### 4. Measuring Instrument

Instrument	Manufacturer	Model No.	Asset No.	Cali. Interval	Cali. Due Date	Test Site
EMI Test Receiver	R&S	ESR7	MRTSUE06001	1 year	2023-12-28	WZ-AC1
Horn Antenna	Schwarzbeck	BBHA 9120D	MRTSUE06023	1 year	2023-08-22	WZ-AC1
Preamplifier	Agilent	83017A	MRTSUE06076	1 year	2024-05-07	WZ-AC1
TRILOG Antenna	Schwarzbeck	VULB 9168	MRTSUE06172	1 year	2024-06-09	WZ-AC1
Anechoic Chamber	TDK	WZ-AC1	MRTSUE06212	1 year	2024-04-20	WZ-AC1
Thermohygrometer	testo	608-H1	MRTSUE06403	1 year	2024-05-31	WZ-AC1
Signal Analyzer	Keysight	N9010B	MRTSUE06607	1 year	2023-12-28	WZ-AC1
Thermohygrometer	testo	608-H1	MRTSUE11039	1 year	2023-11-01	WZ-AC1
Loop Antenna	Schwarzbeck	FMZB 1519	MRTSUE06025	1 year	2023-09-29	WZ-AC1
Horn Antenna	Schwarzbeck	BBHA 9170	MRTSUE06597	1 year	2023-11-05	WZ-AC2
Preamplifier	EMCI	EMC184045SE	MRTSUE06640	1 year	2024-01-12	WZ-AC2
TRILOG Antenna	Schwarzbeck	VULB 9162	MRTSUE06022	1 year	2024-05-15	WZ-AC2
EMI Test Receiver	Agilent	N9038A	MRTSUE06125	1 year	2024-05-23	WZ-AC2
Thermohygrometer	Mingle	ETH529	MRTSUE06170	1 year	2023-11-27	WZ-AC2
Horn Antenna	Schwarzbeck	BBHA 9120D	MRTSUE06171	1 year	2023-10-13	WZ-AC2
Preamplifier	Schwarzbeck	BBV 9718	MRTSUE06176	1 year	2024-05-07	WZ-AC2
Anechoic Chamber	RIKEN	WZ-AC2	MRTSUE06213	1 year	2024-04-20	WZ-AC2
Thermohygrometer	testo	608-H1	MRTSUE11038	1 year	2023-11-01	WZ-AC2
Two-Line V-Network	R&S	ENV216	MRTSUE06002	1 year	2024-05-23	WZ-SR2
Shielding Room	MIX-BEP	WZ-SR2	MRTSUE06215	5 years	2026-12-20	WZ-SR2
Thermohygrometer	testo	608-H1	MRTSUE06404	1 year	2024-05-31	WZ-SR2
Four-Line V-Network	R&S	ENV432	MRTSUE06615	1 year	2023-10-08	WZ-SR2
EMI Test Receiver	R&S	ESR3	MRTSUE06909	1 year	2023-10-27	WZ-SR2
Thermohygrometer	testo	608-H1	MRTSUE06402	1 year	2024-05-31	WZ-SR5
Shielding Room	HUAMING	WZ-SR5	MRTSUE06442	N/A	N/A	WZ-SR5
Signal Analyzer	Keysight	N9010B	MRTSUE06457	1 year	2024-05-23	WZ-SR5
USB Power Sensor	Keysight	U2021XA	MRTSUE06446	1 year	2024-05-23	WZ-SR5
Temperature Chamber	BAOYT	BYH-150CL	MRTSUE06051	1 year	2023-10-08	WZ-TR3
Thermohygrometer	testo	608-H1	MRTSUE06401	1 year	2024-05-31	WZ-TR3
Signal Analyzer	R&S	FSV40	MRTSUE06218	1 year	2023-09-06	WZ-TR3

Software	Version	Function
EMI Software	V3.0.0	EMI Test Software
Controller_MF 7802	2.03C	RE Antenna & Turntable
Controller_MF 7802	1.02	RE Antenna & Turntable
BenchVue Power Meter	2018.1	Power

## 5. Decision Rules and Measurement Uncertainty

### 5.1. Decision Rules

The Decision Rule is based on Simple Acceptance in accordance with ISO Guide 98-4: 2012 Clause 8.2. (Measurement uncertainty is not taken into account when stating conformity with a specified requirement.)

### 5.2. Measurement Uncertainty

Where relevant, the following test uncertainty levels have been estimated for tests performed on the EUT as specified in CISPR 16-4-2. This uncertainty represents an expanded uncertainty expressed at approximately the 95% confidence level using a coverage factor of  $k = 2$ .

<b>AC Conducted Emission Measurement</b>	
Measurement Uncertainty for a Level of Confidence of 95% ( $U=2Uc(y)$ ):	
9kHz~150kHz:	3.58dB
150kHz~30MHz:	3.20dB
<b>Radiated Disturbance</b>	
Measurement Uncertainty for a Level of Confidence of 95% ( $U=2Uc(y)$ ):	
Coaxial:	9kHz~30MHz: 2.59dB
Coplanar:	9kHz~30MHz: 2.60dB
Horizontal:	30MHz~200MHz: 3.85dB
	200MHz~1GHz: 4.36dB
	1GHz~40GHz: 4.98dB
Vertical:	30MHz~200MHz: 4.06dB
	200MHz~1GHz: 5.28dB
	1GHz~40GHz: 4.91dB
<b>Spurious Emissions, Conducted</b>	
Measuring Uncertainty for a Level of Confidence of 95% ( $U=2Uc(y)$ ):	
2.3dB	
<b>Output Power</b>	
Measuring Uncertainty for a Level of Confidence of 95% ( $U=2Uc(y)$ ):	
1.5dB	
<b>Power Spectrum Density</b>	
Measuring Uncertainty for a Level of Confidence of 95% ( $U=2Uc(y)$ ):	
2.3dB	
<b>Occupied Bandwidth</b>	
Measuring Uncertainty for a Level of Confidence of 95% ( $U=2Uc(y)$ ):	
3.2%	



## 6. Test Result

### 6.1. Summary

FCC Section(s)	Test Description	Test Condition	Verdict
15.407(a)	26dB Bandwidth	Conducted	Pass
15.407(e)	6dB Bandwidth		Pass
15.407(a)(3)(iii)	Maximum Conducted Output Power		Pass
15.407(a)(3)(iii)	Peak Power Spectral Density		Pass
15.407(g)	Frequency Stability		Pass
15.407(b)(5)	Undesirable Emissions	Radiated	Pass
15.205, 15.209	General Field Strength Limits (Restricted Bands and Radiated Emission Limits)		Pass
15.207	AC Conducted Emissions 150kHz - 30MHz	Line Conducted	Pass

#### Notes:

- The analyzer plots shown in this section were all taken with a correction table loaded into the analyzer. The correction table was used to account for the losses of the cables and attenuators used as part of the system to connect the EUT to the analyzer at all frequencies of interest.
- For radiated emission test, every axis (X, Y, Z) was also verified. The test results shown in the following sections represent the worst-case emissions.

## 6.2. 26dB & 99% Bandwidth Measurement

### 6.2.1. Test Limit

N/A

### 6.2.2. Test Procedure

KDB 789033 D02v02r01- Section II)C)1) (26dB Bandwidth)

KDB 789033 D02v02r01- Section II)D) (99% Bandwidth)

### 6.2.3. Test Setting

#### 26dB Bandwidth

1. The analyzers' automatic bandwidth measurement capability was used to perform the 26dB bandwidth measurement. The "X" dB bandwidth parameter was set to  $X = 26$ . The automatic bandwidth measurement function also has the capability of simultaneously measuring the 99% occupied bandwidth. The bandwidth measurement was not influenced by any intermediated power nulls in the fundamental emission.
2. RBW = approximately 1% of the emission bandwidth.
3. VBW > RBW.
4. Detector = Peak.
5. Trace mode = max hold.

#### 99% Bandwidth

1. Set center frequency to the nominal EUT channel center frequency.
2. Set span = 1.5 times to 5.0 times the OBW.
3. Set RBW = 1% to 5% of the OBW
4. Set VBW  $\geq 3 \times$  RBW
5. Detector = Peak.
6. Use the 99% power bandwidth function of the instrument.

### 6.2.4. Test Setup

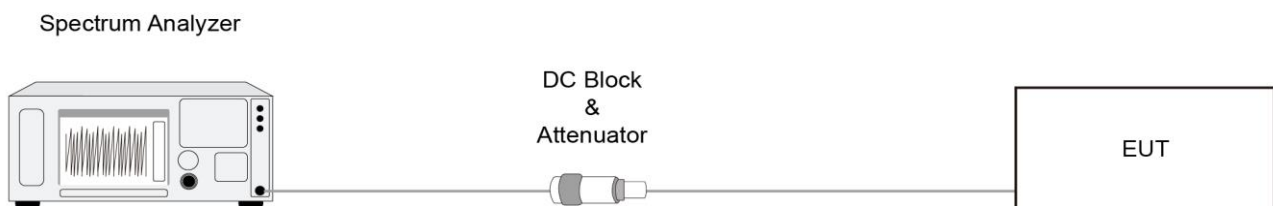

### **6.2.5. Test Result**

Refer to Appendix A.2.

### 6.3. 6dB Bandwidth Measurement

#### 6.3.1. Test Limit

The minimum 6dB bandwidth shall be at least 500 kHz.

#### 6.3.2. Test Procedure

KDB 789033 D02v02r01- Section II)C)2)

#### 6.3.3. Test Setting

1. Set center frequency to the nominal EUT channel center frequency.
2. RBW = 100 kHz.
3. VBW  $\geq 3 \times$  RBW.
4. Detector = Peak.
5. Trace mode = max hold.
6. Sweep = auto couple.
7. Allow the trace to stabilize.
8. Measure the maximum width of the emission that is constrained by the frequencies associated with the two outermost amplitude points (upper and lower frequencies) that are attenuated by 6 dB relative to the maximum level measured in the fundamental emission.

#### 6.3.4. Test Setup

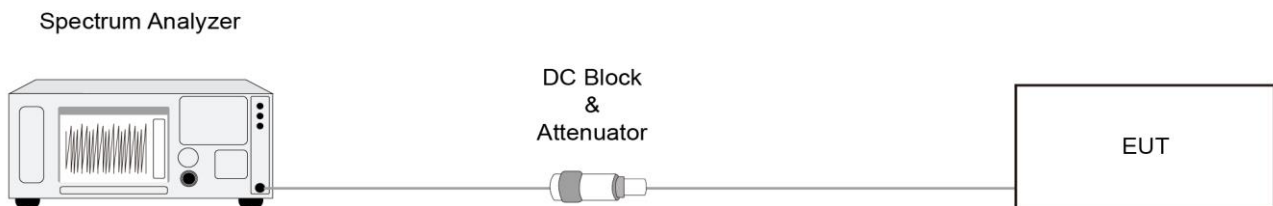

#### 6.3.5. Test Result

Refer to Appendix A.3.

## 6.4. Output Power Measurement

### 6.4.1. Test Limit

For client devices operating under the control of an indoor access point in the 5.850–5.895 GHz band, the maximum e.i.r.p. over the frequency band of operation must not exceed 30 dBm. Client devices operating on a channel that spans the 5.725–5.850 GHz and 5.850–5.895 GHz bands must not exceed an e.i.r.p. of 30 dBm.

### 6.4.2. Test Procedure

KDB 789033D02v02r01- Section II)E)3)b) Method PM-G

### 6.4.3. Test Setting

#### Average Power Measurement

Average power measurements were performed only when the EUT was transmitting at its maximum power control level using a broadband power meter with a pulse sensor. The power meter implemented triggering and gating capabilities which were set up such that power measurements were recorded only during the ON time of the transmitter.

### 6.4.4. Test Setup

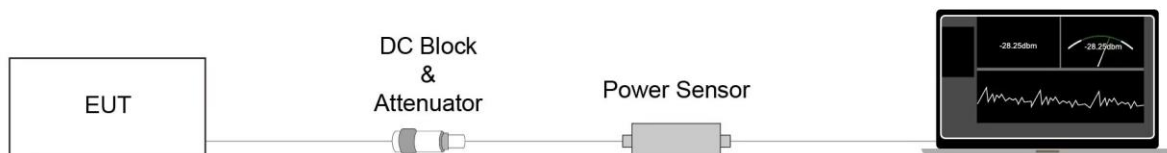

### 6.4.5. Test Result

Refer to Appendix A.4.

## 6.5. Power Spectral Density Measurement

### 6.5.1. Test Limit

For client devices operating under the control of an indoor access point in the 5.850–5.895 GHz band, the maximum power spectral density must not exceed 14 dBm e.i.r.p. in any 1-megahertz band.

### 6.5.2. Test Procedure

KDB 789033 D02v02r01-Section II(F)

### 6.5.3. Test Setting

1. Analyzer was set to the center frequency of the UNII channel under investigation
2. Span was set to encompass the entire 26dB EBW of the signal.
3. RBW = 1MHz
4. VBW = 3 × RBW
5. Number of sweep points  $\geq 2 \times (\text{span} / \text{RBW})$
6. Detector = power averaging (Average)
7. Sweep time = auto
8. Trigger = free run
9. Use the peak search function on the instrument to find the peak of the spectrum and record its value.
10. Add  $10 \cdot \log(1/x)$ , where  $x$  is the duty cycle, to the measured power in order to compute the average power during the actual transmission times (because the measurement represents an average over both the on and off times of the transmission). For example, add  $10 \cdot \log(1/0.25) = 6$  dB if the duty cycle is 25 percent.

### 6.5.4. Test Setup

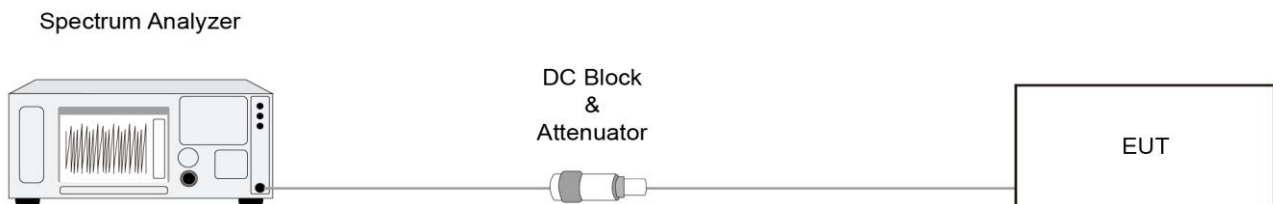

### 6.5.5. Test Result

Refer to Appendix A.5.

## 6.6. Frequency Stability Measurement

### 6.6.1. Test Limit

Manufactures of U-NII devices are responsible for ensuring frequency stability such that an emission is maintained within the band of operation under all conditions of normal operation as specified in the user's manual.

### 6.6.2. Test Procedure

#### Frequency Stability Under Temperature Variations:

The equipment under test was connected to an external AC or DC power supply and input rated voltage. RF output was connected to a frequency counter or spectrum analyzer via feed through attenuators. The EUT was placed inside the temperature chamber. Set the spectrum analyzer RBW low enough to obtain the desired frequency resolution and measure EUT 20°C operating frequency as reference frequency. Turn EUT off and set the chamber temperature to highest. After the temperature stabilized for approximately 30 minutes recorded the frequency. Repeat step measure with 10°C decreased per stage until the lowest temperature reached.

#### Frequency Stability Under Voltage Variations:

Set chamber temperature to 20°C. Use a variable AC power supply / DC power source to power the EUT and set the voltage to rated voltage. Set the spectrum analyzer RBW low enough to obtain the desired frequency resolution and recorded the frequency.

Reduce the input voltage to specify extreme voltage variation ( $\pm 15\%$ ) and endpoint, record the maximum frequency change.

### 6.6.3. Test Setup

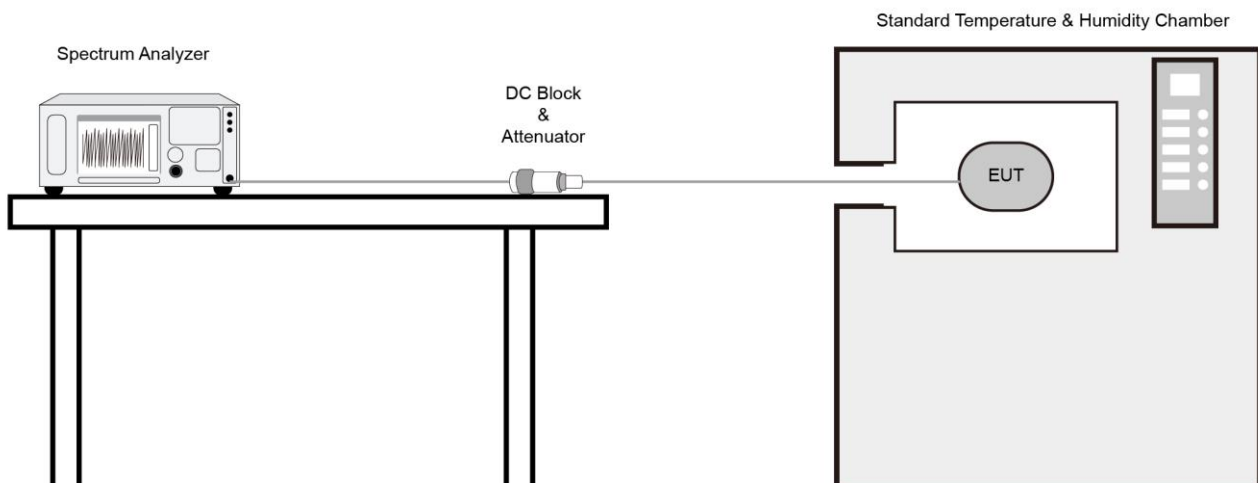

#### **6.6.4. Test Result**

Refer to Appendix A.6.



## 6.7. Radiated Spurious Emission Measurement

### 6.7.1. Test Limit

All out of band emissions appearing in a restricted band as specified in Section 15.205 of the Title 47 CFR must not exceed the limits shown in Table per Section 15.209.

FCC Part 15 Subpart C Paragraph 15.209		
Frequency [MHz]	Field Strength [ $\mu\text{V/m}$ ]	Measured Distance [Meters]
0.009 - 0.490	2400/F (kHz)	300
0.490 - 1.705	24000/F (kHz)	30
1.705 - 30	30	30
30 - 88	100	3
88 - 216	150	3
216 - 960	200	3
Above 960	500	3

### 6.7.2. Test Procedure

KDB 789033 D02v02r01- Section II)G)

### 6.7.3. Test Setting

**Table 1 - RBW as a function of frequency**

Frequency	RBW
9 ~ 150 kHz	200 ~ 300 Hz
0.15 ~ 30 MHz	9 ~ 10 kHz
30 ~ 1000 MHz	100 ~ 120 kHz
> 1000MHz	1MHz

**Quasi-Peak Measurements below 1GHz**

1. Analyzer center frequency was set to the frequency of the radiated spurious emission of interest
2. Span was set greater than 1MHz
3. RBW = as specified in Table 1
4. Detector = CISPR quasi-peak
5. Sweep time = auto couple
6. Trace was allowed to stabilize

**Peak Measurements above 1GHz**

1. Analyzer center frequency was set to the frequency of the radiated spurious emission of interest
2. RBW = 1MHz
3. VBW = 3MHz
4. Detector = peak
5. Sweep time = auto couple
6. Trace mode = max hold
7. Trace was allowed to stabilize

**Average Measurements above 1GHz (Method VB)**

1. Analyzer center frequency was set to the frequency of the radiated spurious emission of interest
2. RBW = 1MHz
3. VBW; If the EUT is configured to transmit with duty cycle  $\geq 98\%$ , set VBW = 10 Hz.

If the EUT duty cycle is  $< 98\%$ , set  $VBW \geq 1/T$ . T is the minimum transmission duration.

802.11a	10Hz	802.11ac-VHT20	10Hz	802.11ac-VHT40	10Hz
802.11ac-VHT80	10Hz	802.11ax-HE20	10Hz	802.11ax-HE40	10Hz
802.11ax-HE80	10Hz	--	--	--	--

4. Detector = Peak
5. Sweep time = auto
6. Trace mode = max hold
7. Trace was allowed to stabilize

### 6.7.4. Test Setup

Below 30MHz Test Setup:

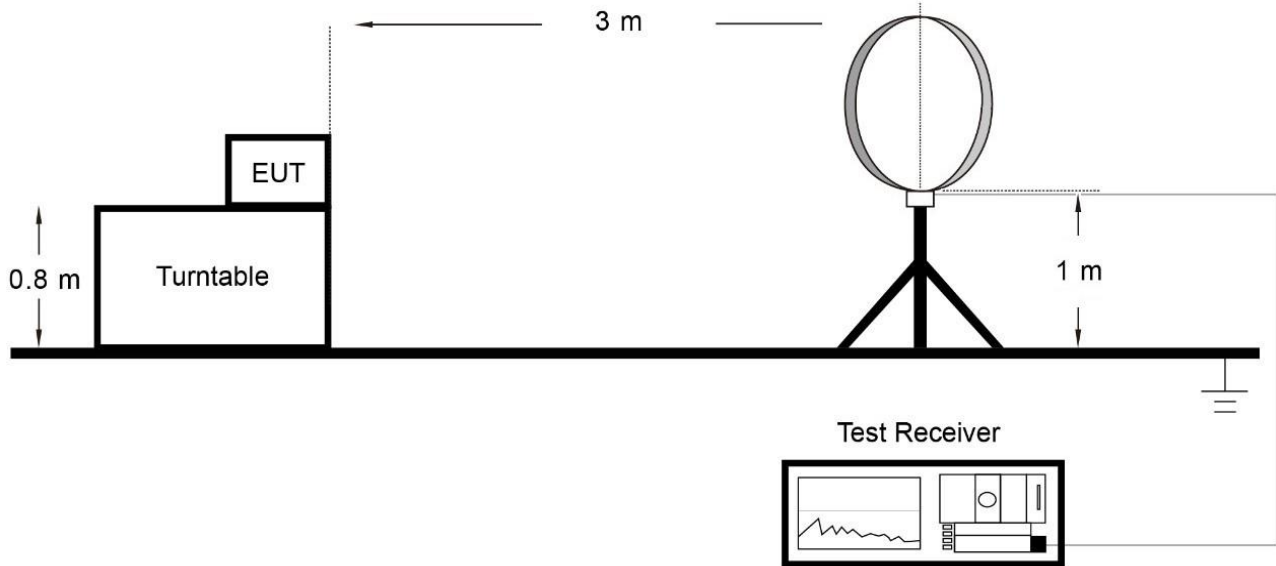

Below 1GHz Test Setup:

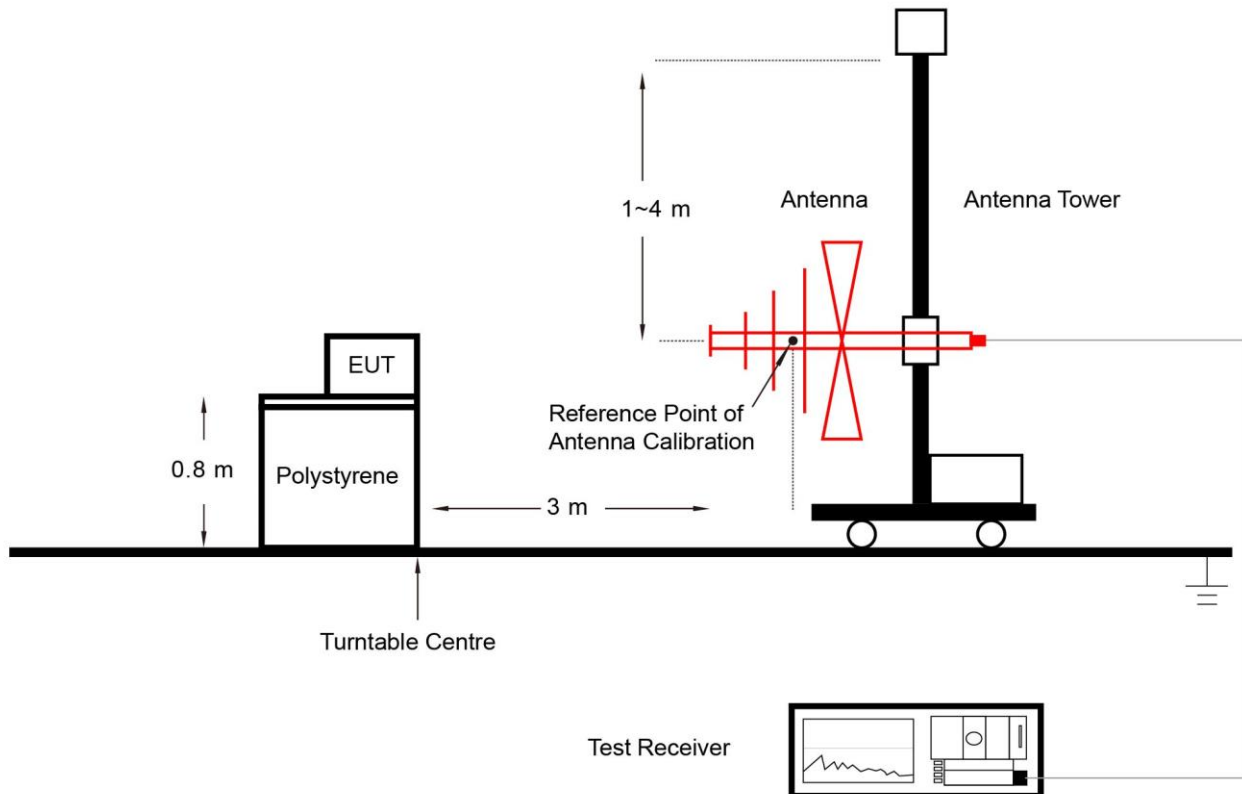

Above 1GHz Test Setup:

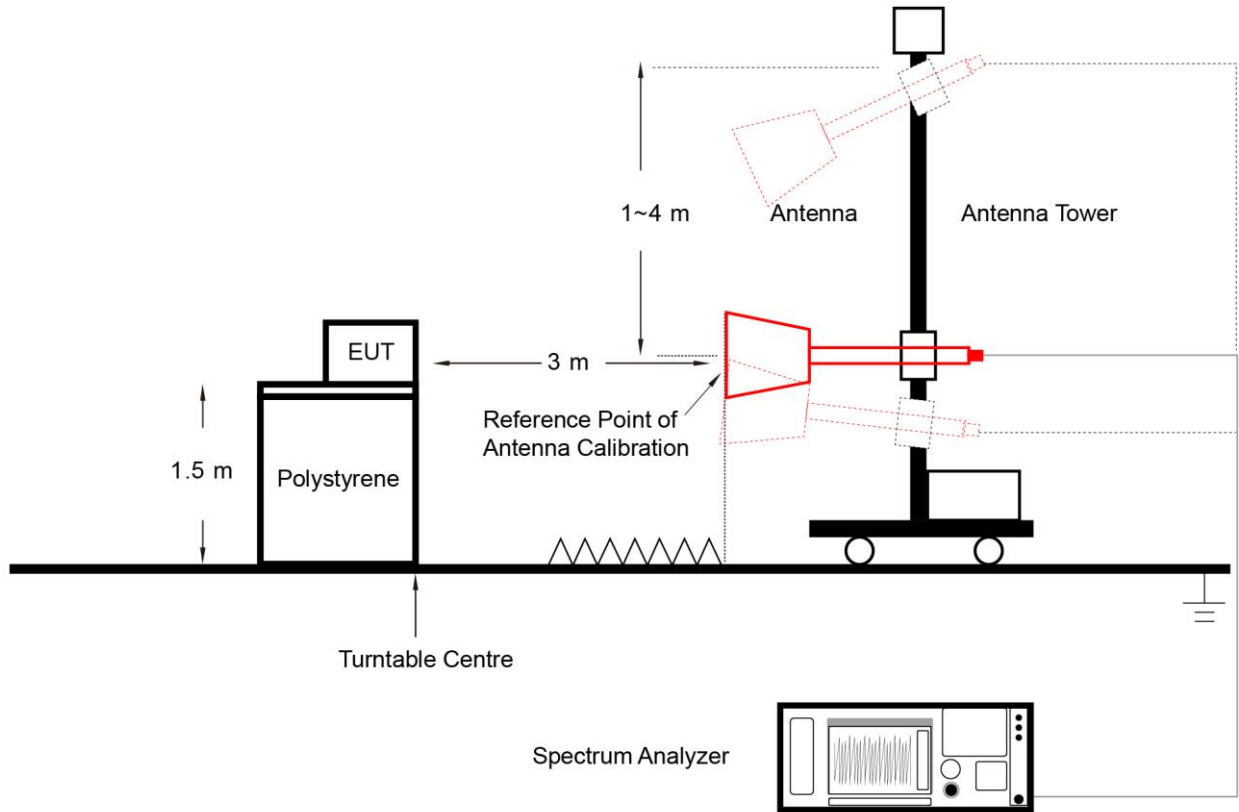

**6.7.5. Test Result**

Refer to Appendix A.7.

## 6.8. Radiated Restricted Band Edge Measurement

### 6.8.1. Test Limit

#### For 15.205 requirement:

Radiated emissions which fall in the restricted bands, as defined in Section 15.205(a) of FCC part 15, must also comply with the radiated emission limits specified in Section 15.209(a).

Frequency (MHz)	Frequency (MHz)	Frequency (MHz)	Frequency (GHz)
0.090 - 0.110	16.42 - 16.423	399.9 - 410	4.5 - 5.15
<sup>1</sup> 0.495 - 0.505	16.69475 - 16.69525	608 - 614	5.35 - 5.46
2.1735 - 2.1905	16.80425 - 16.80475	960 - 1240	7.25 - 7.75
4.125 - 4.128	25.5 - 25.67	1300 - 1427	8.025 - 8.5
4.17725 - 4.17775	37.5 - 38.25	1435 - 1626.5	9.0 - 9.2
4.20725 - 4.20775	73 - 74.6	1645.5 - 1646.5	9.3 - 9.5
6.215 - 6.218	74.8 - 75.2	1660 - 1710	10.6 - 12.7
6.26775 - 6.26825	108 - 121.94	1718.8 - 1722.2	13.25 - 13.4
6.31175 - 6.31225	123 - 138	2200 - 2300	14.47 - 14.5
8.291 - 8.294	149.9 - 150.05	2310 - 2390	15.35 - 16.2
8.362 - 8.366	156.52475 - 156.52525	2483.5 - 2500	17.7 - 21.4
8.37625 - 8.38675	156.7 - 156.9	2690 - 2900	22.01 - 23.12
8.41425 - 8.41475	162.0125 - 167.17	3260 - 3267	23.6 - 24.0
12.29 - 12.293	167.72 - 173.2	3332 - 3339	31.2 - 31.8
12.51975 - 12.52025	240 - 285	3345.8 - 3358	36.43 - 36.5
12.57675 - 12.57725	322 - 335.4	3600 - 4400	( <sup>2</sup> )
13.36 - 13.41	--	--	--

For 15.407(b) requirement:

For a client device, all emissions at or above 5.895 GHz shall not exceed an e.i.r.p. of  $-5$  dBm/MHz and shall decrease linearly to an e.i.r.p. of  $-27$  dBm/MHz at or above 5.925 GHz.

For a client device or indoor access point or subordinate device, all emissions below 5.725 GHz shall not exceed an e.i.r.p. of  $-27$  dBm/MHz at 5.65 GHz increasing linearly to 10 dBm/MHz at 5.7 GHz, and from 5.7 GHz increasing linearly to a level of 15.6 dBm/MHz at 5.72 GHz, and from 5.72 GHz increasing linearly to a level of 27 dBm/MHz at 5.725 GHz.

$E$  [dB $\mu$ V/m] = EIRP [dBm] + 95.2, for example,  $-27$  dBm/MHz = 68.2 dB $\mu$ V/m

All out of band emissions appearing in a restricted band as specified in Section 15.205 of the Title 47CFR must not exceed the limits shown in Table per Section 15.209.

FCC Part 15 Subpart C Paragraph 15.209		
Frequency [MHz]	Field Strength [ $\mu$ V/m]	Measured Distance [Meters]
0.009 - 0.490	2400/F (kHz)	300
0.490 - 1.705	24000/F (kHz)	30
1.705 - 30	30	30
30 - 88	100	3
88 - 216	150	3
216 - 960	200	3
Above 960	500	3

**6.8.2. Test Procedure**

KDB 789033 D02v02r01- Section II)G)

**6.8.3. Test Setting**

**Peak Measurements above 1GHz**

1. Analyzer center frequency was set to the frequency of the radiated spurious emission of interest
2. RBW = 1MHz
3. VBW = 3MHz
4. Detector = Peak
5. Sweep time = Auto couple
6. Trace mode = Max hold
7. Trace was allowed to stabilize

**Average Measurements above 1GHz (Method VB)**

1. Analyzer center frequency was set to the frequency of the radiated spurious emission of interest
2. RBW = 1MHz
3. VBW; if the EUT is configured to transmit with duty cycle  $\geq 98\%$ , set VBW = 10Hz
4. If the EUT duty cycle is  $< 98\%$ , set  $VBW \geq 1/T$ . T is the minimum transmission duration

802.11a	10Hz	802.11ac-VHT20	10Hz	802.11ac-VHT40	10Hz
802.11ac-VHT80	10Hz	802.11ax-HE20	10Hz	802.11ax-HE40	10Hz
802.11ax-HE80	10Hz	--	--	--	--

5. Detector = Peak
6. Sweep time = Auto
7. Trace mode = Max hold
8. Trace was allowed to stabilize

### 6.8.4. Test Setup

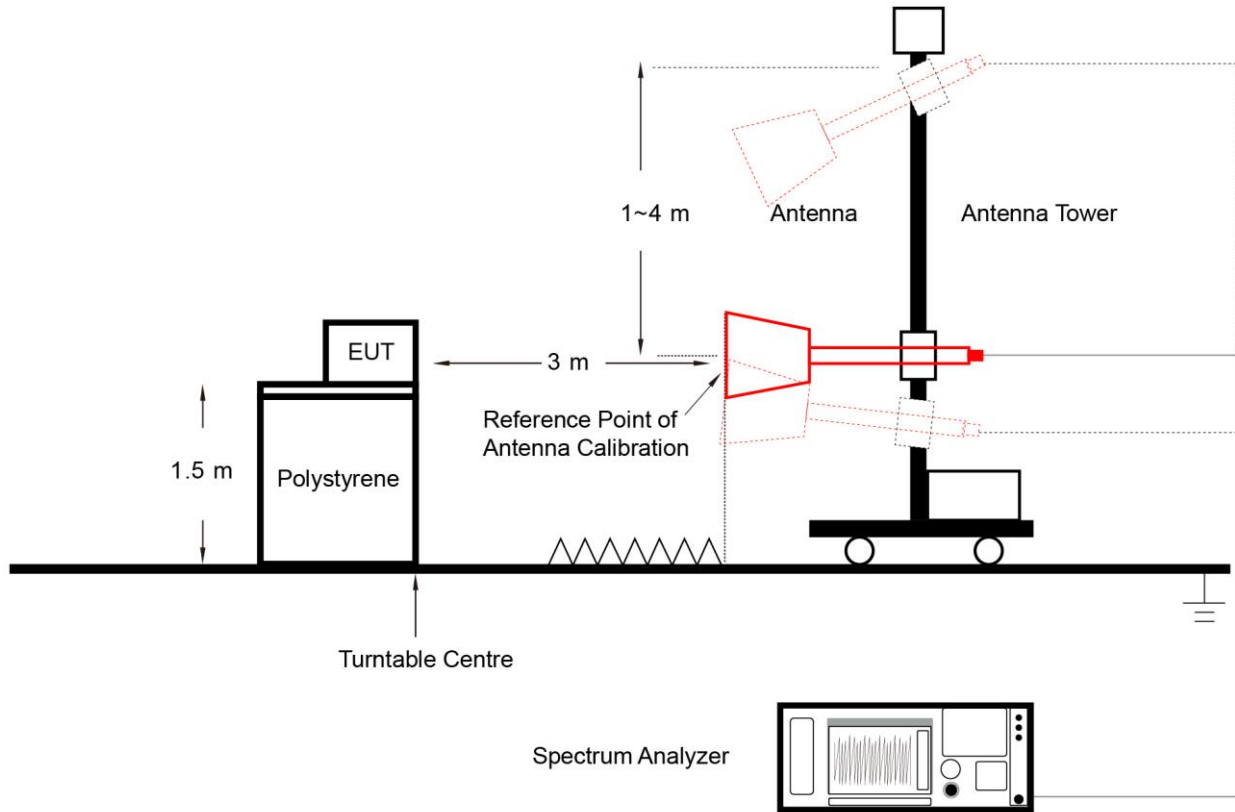

### 6.8.5. Test Result

Refer to Appendix A.8.



## 6.9. AC Conducted Emissions Measurement

### 6.9.1. Test Limit

FCC Part 15.207 Limits		
Frequency (MHz)	QP (dB $\mu$ V)	AV (dB $\mu$ V)
0.15 - 0.50	66 - 56	56 - 46
0.50 - 5.0	56	46
5.0 - 30	60	50

Note 1: The lower limit shall apply at the transition frequencies.

Note 2: The limit decreases linearly with the logarithm of the frequency in the range 0.15MHz to 0.5MHz.

### 6.9.2. Test Setup

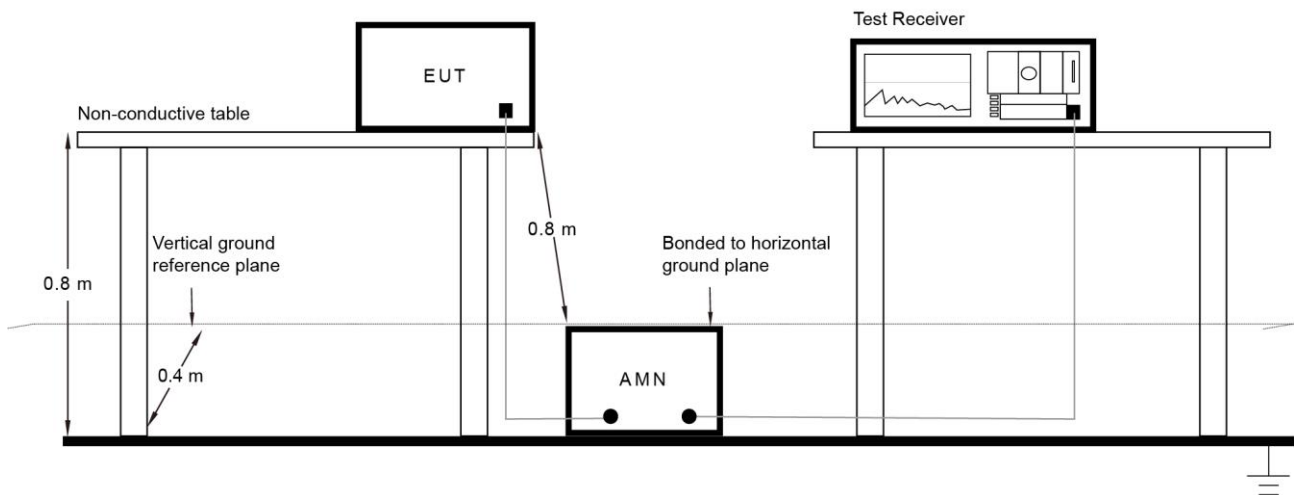

### 6.9.3. Test Result

Refer to Appendix A.9.

## Appendix A - Test Result

### A.1 Duty Cycle Test Result

Test Site	WZ-SR5	Test Engineer	Luis Yang
Test Date	2023-07-03		

Test Mode	Duty Cycle
802.11a	99.05%
802.11ac-VHT20	99.03%
802.11ac-VHT40	98.99%
802.11ac-VHT80	98.76%
802.11ax-HE20	99.03%
802.11ax-HE40	99.03%
802.11ax-HE80	98.77%

Duty Cycle (T = Transmission Duration)

802.11a (T = 3.010ms)

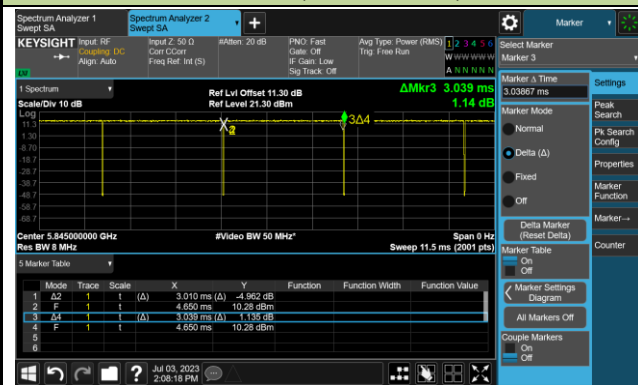

802.11ac-VHT20 (T = 3.051ms)

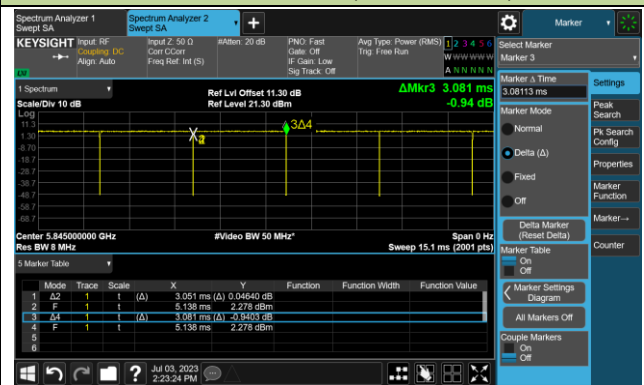

802.11ac-VHT40 (T = 3.028ms)

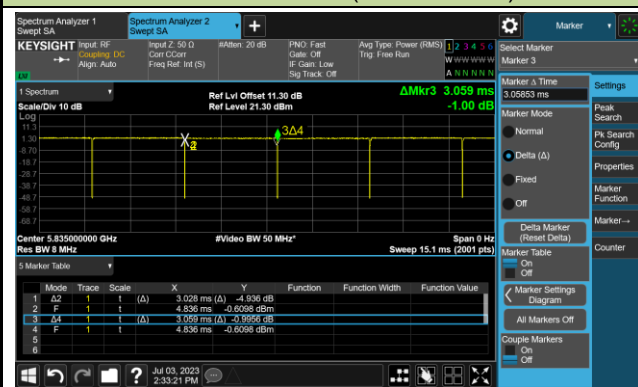

802.11ac-VHT80 (T = 3.021ms)

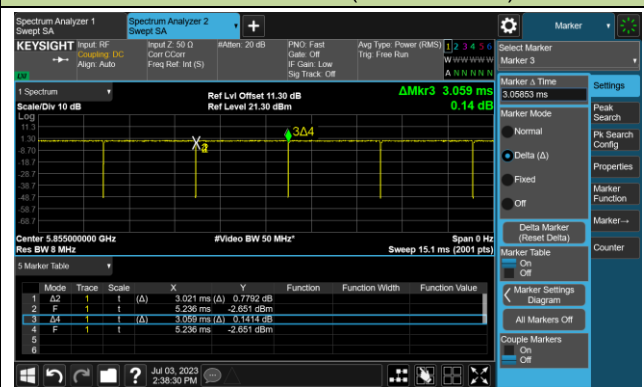

## Duty Cycle (T = Transmission Duration)

802.11ax-HE20 (T = 3.051ms)

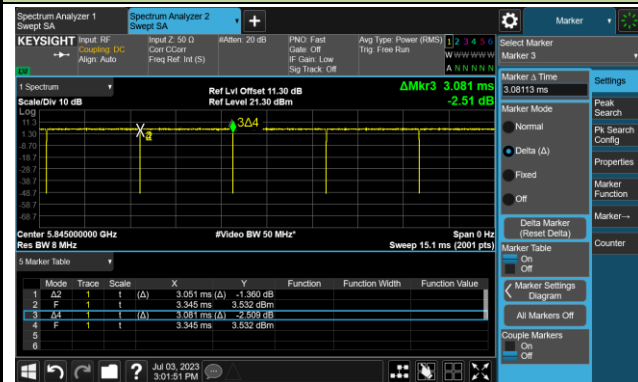

802.11ax-HE40 (T = 3.051ms)

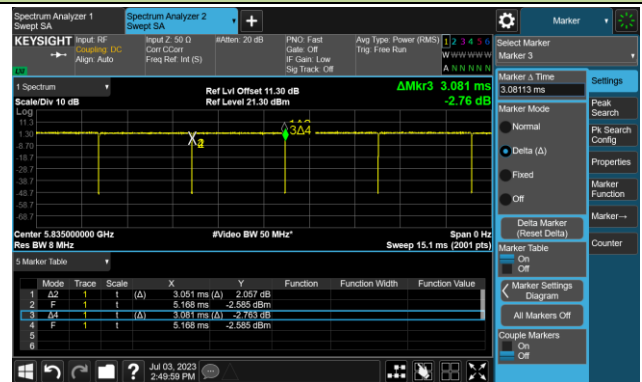

802.11ax-HE80 (T = 3.043ms)

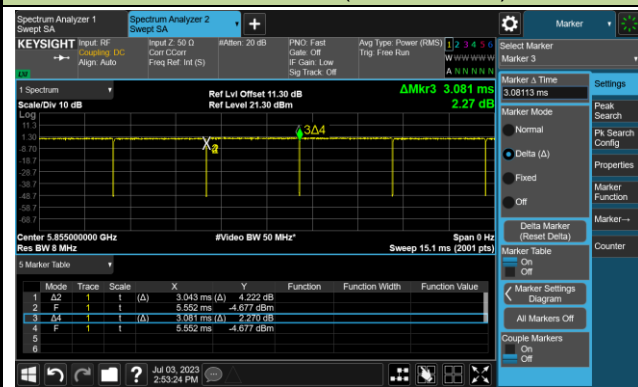

**A.2 26dB & 99% Bandwidth Test Result**

Test Site	WZ-SR5	Test Engineer	Luis Yang
Test Date	2023-07-12		

Test Mode	Data Rate/ MCS	Channel No.	Frequency (MHz)	99% Bandwidth (MHz)	26dB Bandwidth (MHz)
11a	6Mbps	169	5845	16.739	21.96
11a	6Mbps	173	5865	17.011	23.95
11a	6Mbps	177	5885	17.360	28.66
11ac-VHT20	MCS0	169	5845	17.880	21.80
11ac-VHT20	MCS0	173	5865	18.125	26.71
11ac-VHT20	MCS0	177	5885	18.373	27.86
11ac-VHT40	MCS0	167	5835	36.965	67.29
11ac-VHT40	MCS0	175	5875	37.830	72.68
11ac-VHT80	MCS0	171	5855	76.258	116.5
11ax-HE20	MCS0	169	5845	19.007	21.20
11ax-HE20	MCS0	173	5865	19.147	25.33
11ax-HE20	MCS0	177	5885	19.223	31.47
11ax-HE40	MCS0	167	5835	37.702	47.58
11ax-HE40	MCS0	175	5875	38.648	72.21
11ax-HE80	MCS0	171	5855	77.465	113.5

802.11a 26dB & 99% Bandwidth

Channel 169 (5845MHz)

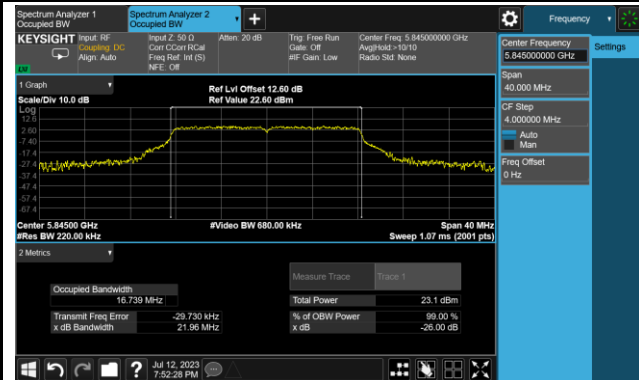

Channel 173 (5865MHz)

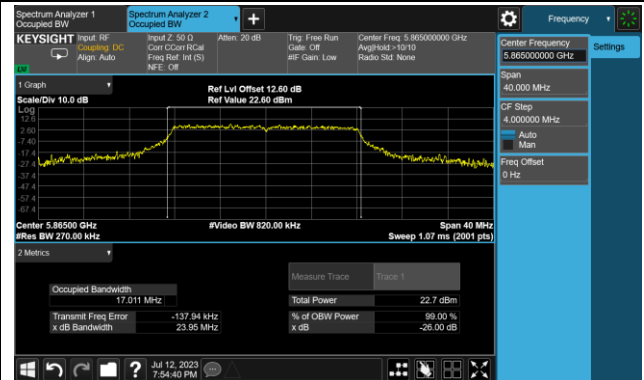

Channel 177 (5885MHz)

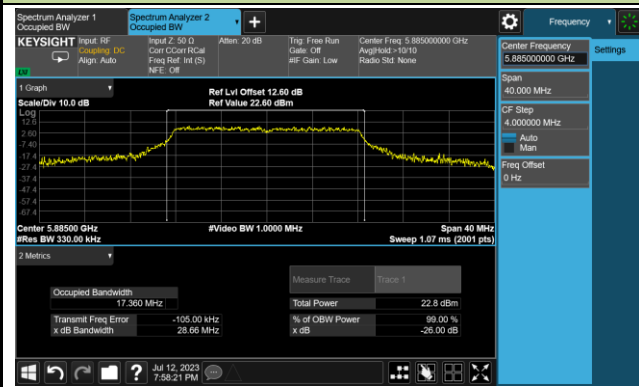

802.11ac-VHT20 26dB & 99% Bandwidth

Channel 169 (5845MHz)

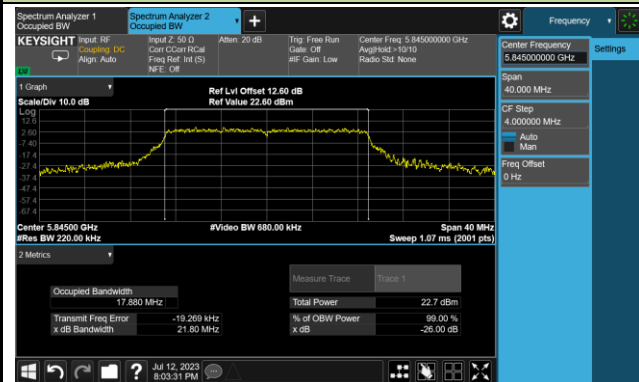

Channel 173 (5865MHz)

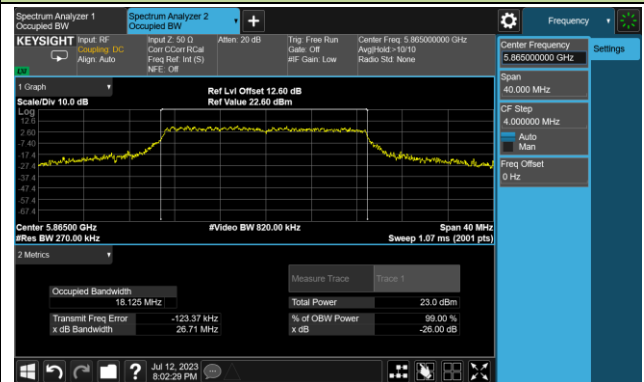

Channel 177 (5885MHz)

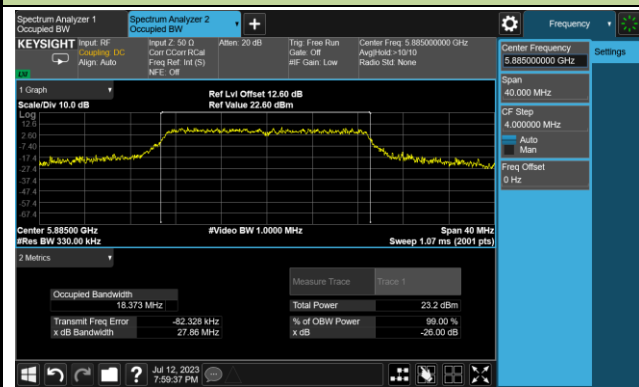

802.11ac-VHT40 26dB & 99% Bandwidth

Channel 167 (5835MHz)

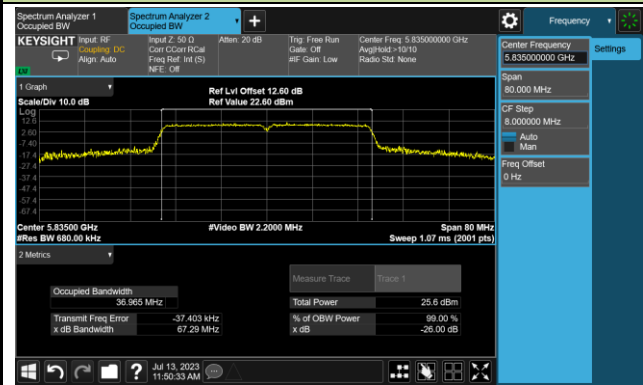

Channel 175(5875MHz)

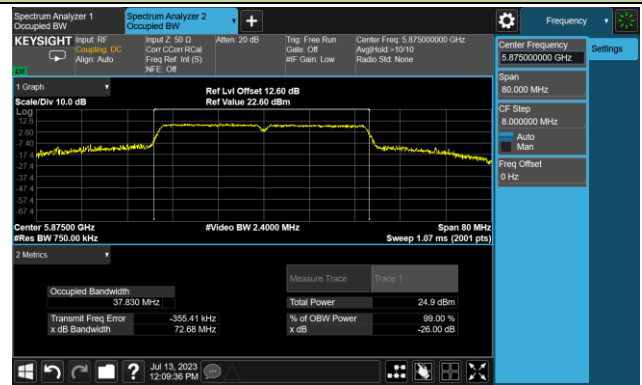

802.11ac-VHT80 26dB & 99% Bandwidth

Channel 171 (5855MHz)

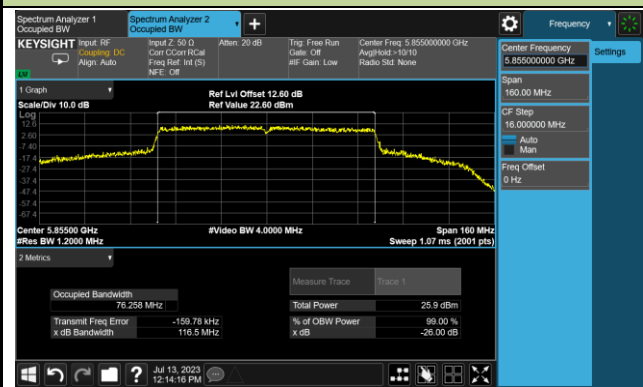

802.11ax-HE20 26dB & 99% Bandwidth

Channel 169 (5845MHz)

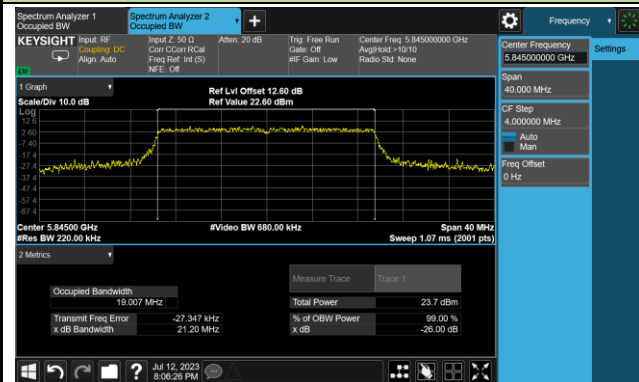

Channel 173 (5865MHz)

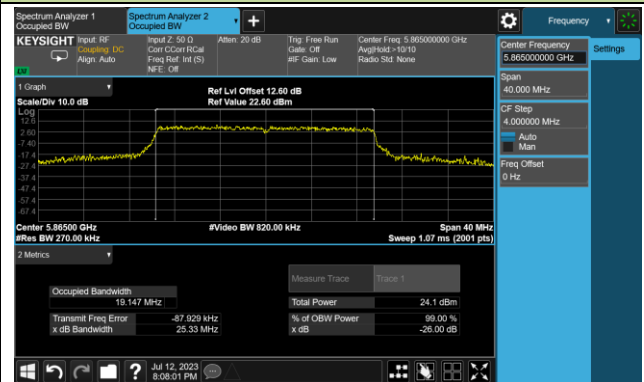

Channel 177 (5885MHz)

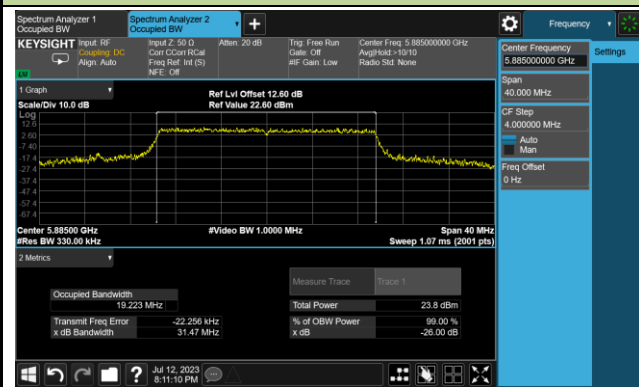



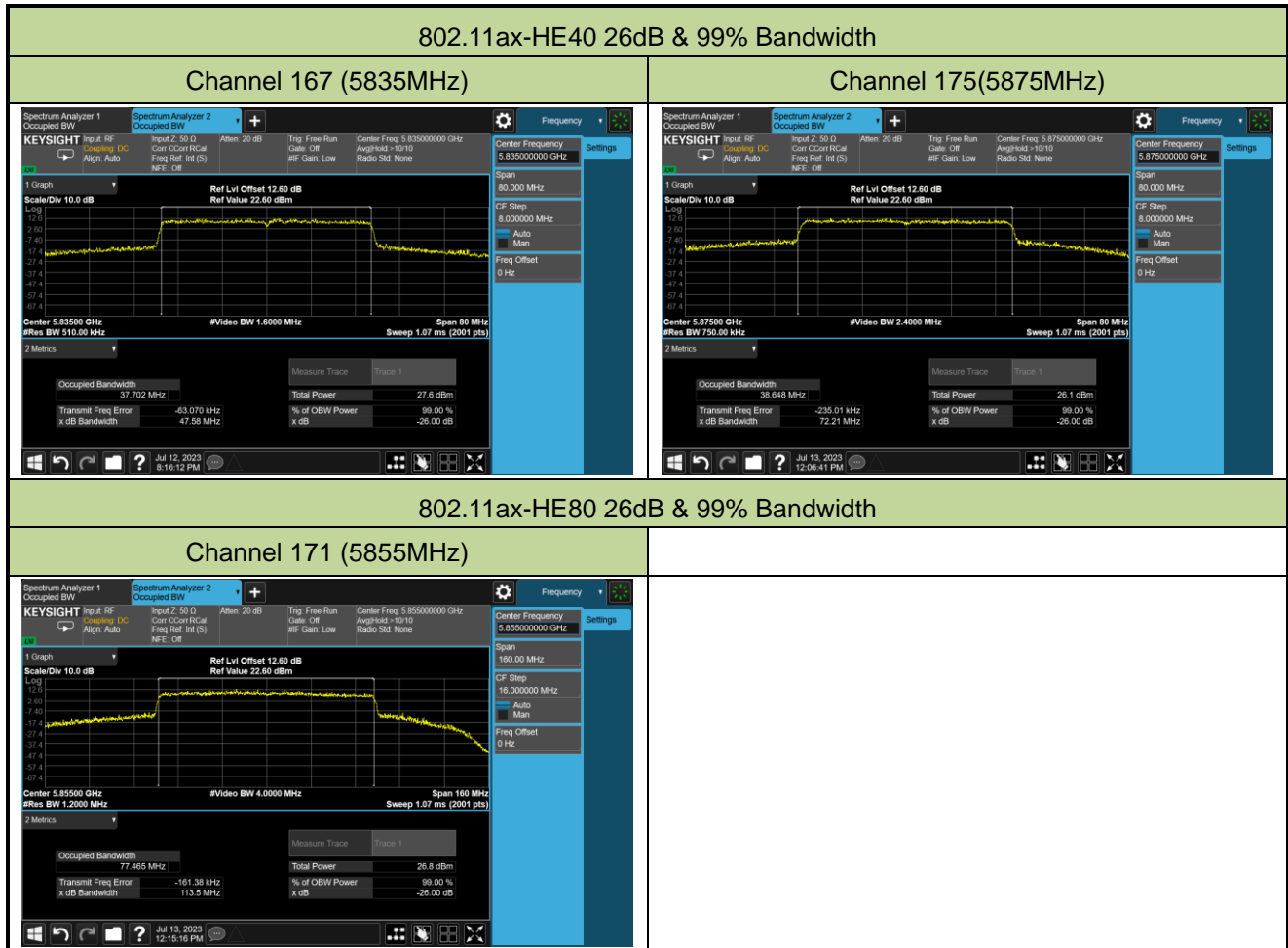

**A.3 6dB Bandwidth Test Result**

Test Site	WZ-SR5	Test Engineer	Luis Yang
Test Date	2023-07-12~2023-07-13		

Test Mode	Data Rate/ MCS	Channel No.	Frequency (MHz)	6dB Bandwidth (MHz)	Limit (MHz)
11a	6Mbps	169	5845	16.41	≥ 0.5
11a	6Mbps	173	5865	16.52	≥ 0.5
11a	6Mbps	177	5885	16.39	≥ 0.5
11ac-VHT20	MCS0	169	5845	17.64	≥ 0.5
11ac-VHT20	MCS0	173	5865	17.60	≥ 0.5
11ac-VHT20	MCS0	177	5885	17.63	≥ 0.5
11ac-VHT40	MCS0	167	5835	36.39	≥ 0.5
11ac-VHT40	MCS0	175	5875	36.37	≥ 0.5
11ac-VHT80	MCS0	171	5855	75.96	≥ 0.5
11ax-HE20	MCS0	169	5845	19.02	≥ 0.5
11ax-HE20	MCS0	173	5865	18.83	≥ 0.5
11ax-HE20	MCS0	177	5885	19.01	≥ 0.5
11ax-HE40	MCS0	167	5835	37.68	≥ 0.5
11ax-HE40	MCS0	175	5875	37.64	≥ 0.5
11ax-HE80	MCS0	171	5855	77.21	≥ 0.5

802.11a 6dB Bandwidth

Channel 169 (5845MHz)

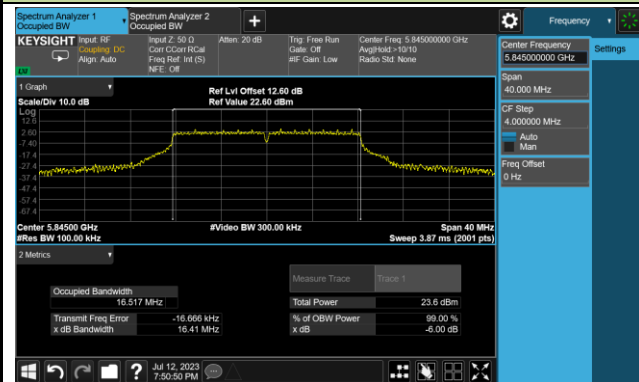

Channel 173 (5865MHz)

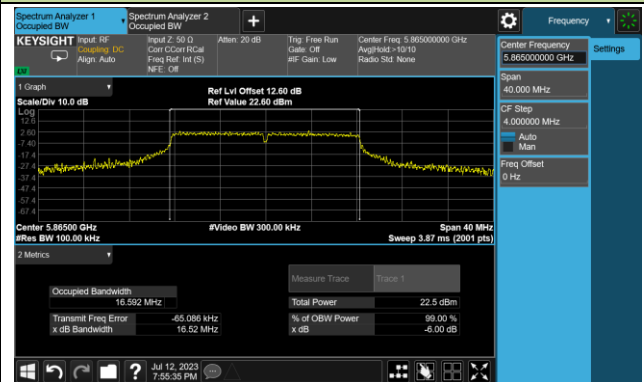

Channel 177 (5885MHz)

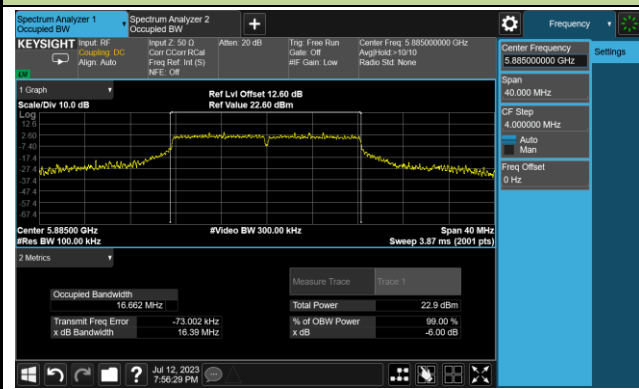

802.11ac-VHT20 6dB Bandwidth

Channel 169 (5845MHz)

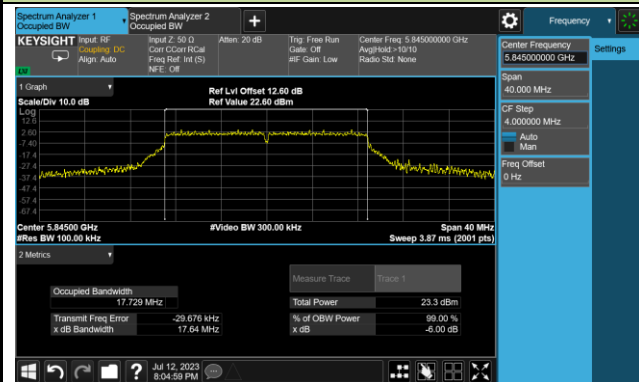

Channel 173 (5865MHz)

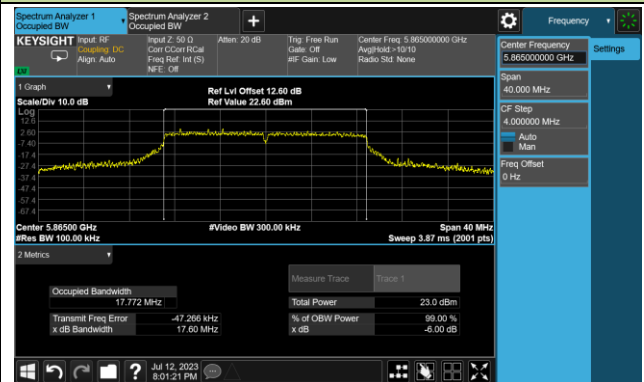

Channel 177 (5885MHz)

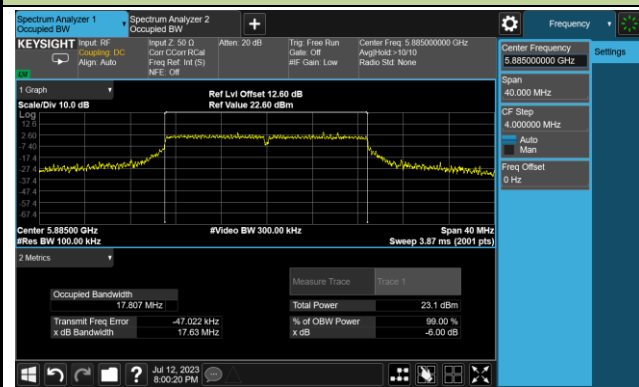

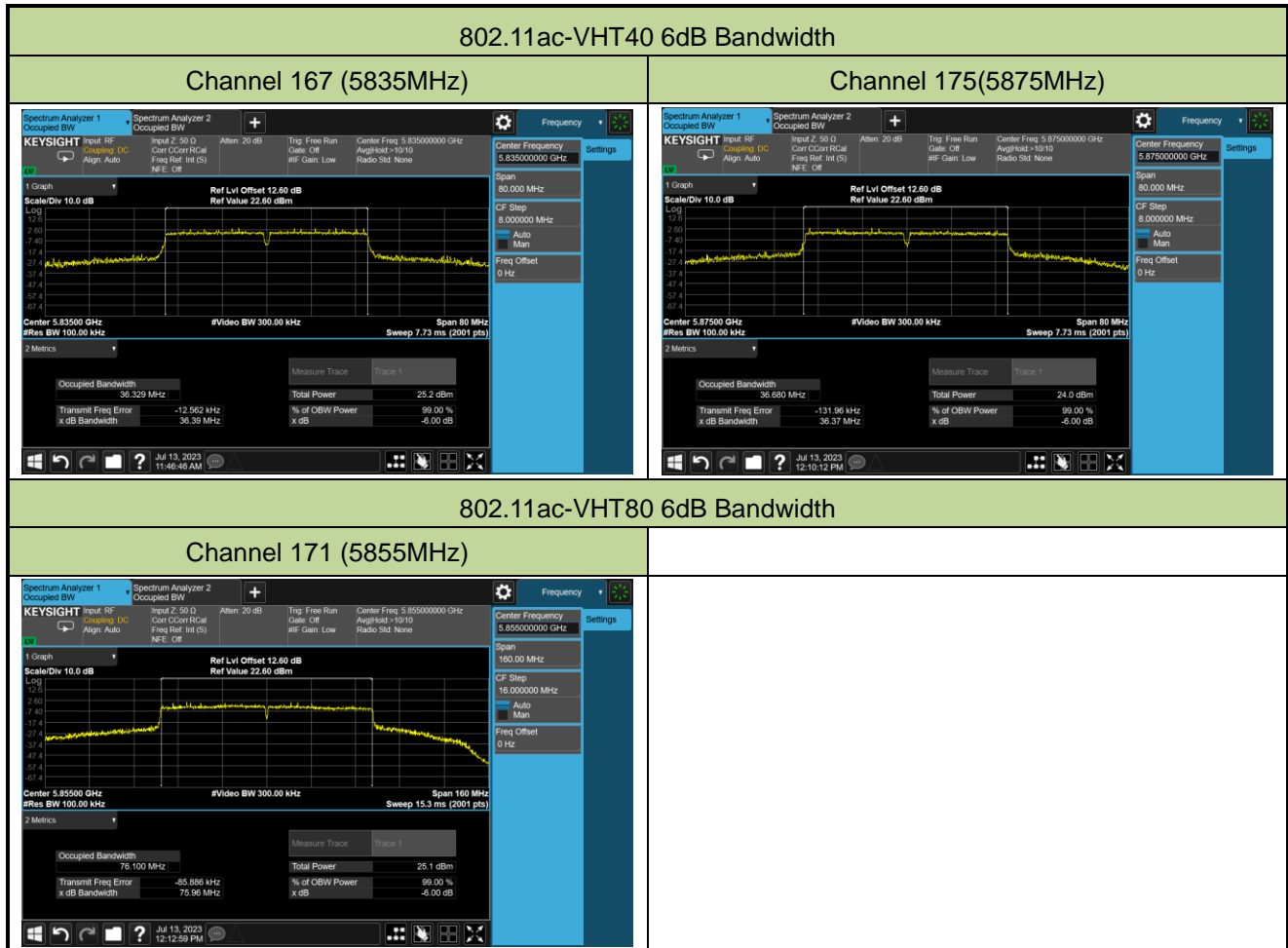

802.11ax-HE20 6dB Bandwidth

Channel 169 (5845MHz)

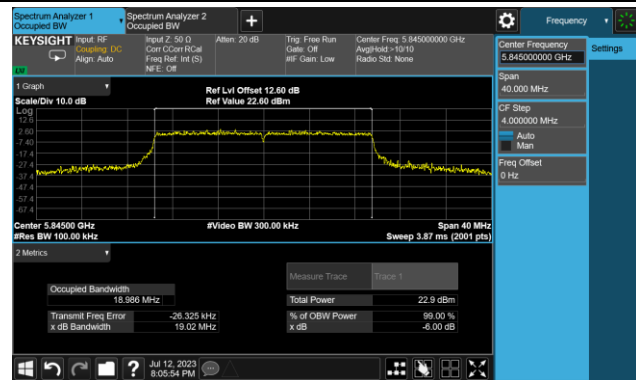

Channel 173 (5865MHz)

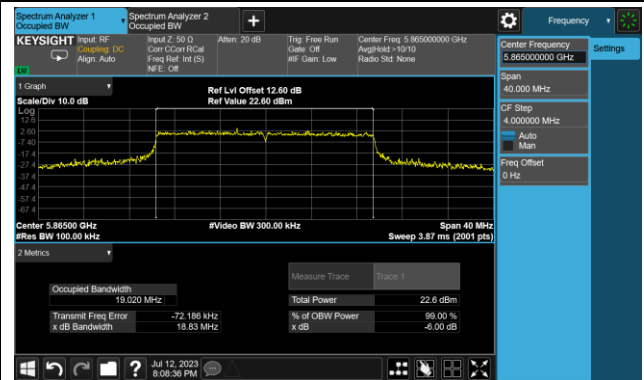

Channel 177 (5885MHz)

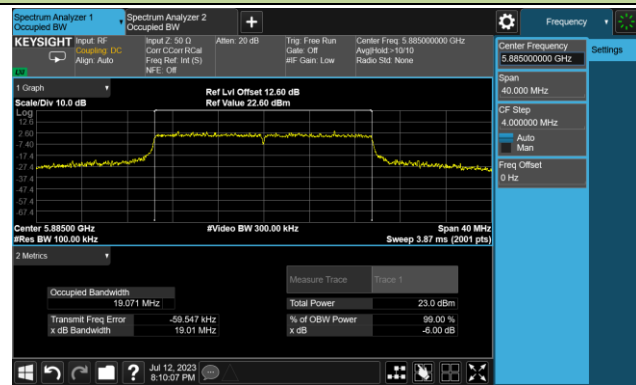

802.11ax-HE40 6dB Bandwidth

Channel 167 (5835MHz)

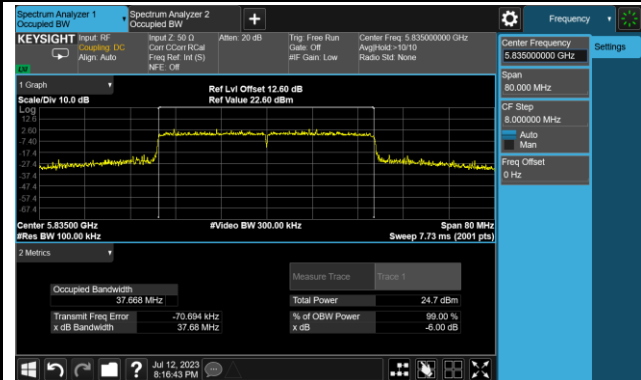

Channel 175(5875MHz)

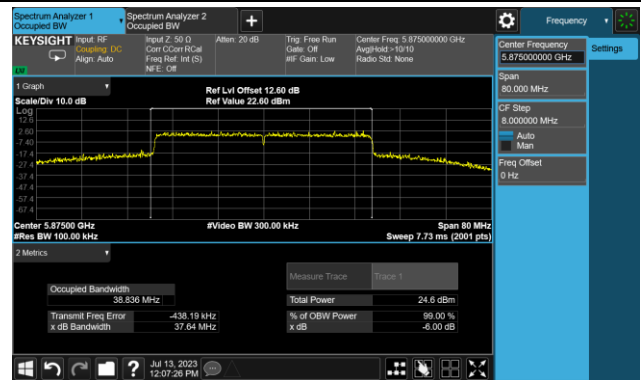

802.11ax-HE80 6dB Bandwidth

Channel 171 (5855MHz)

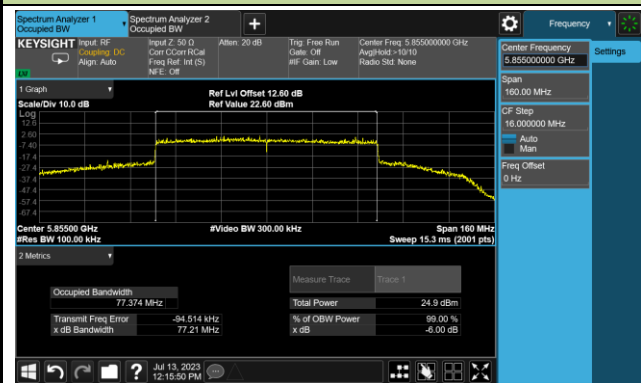

**A.4 Output Power Test Result**

Test Site	WZ-SR5	Test Engineer	Luis Yang
Test Date	2023-07-03		

Test Mode	Data Rate MCS	Channel No.	Freq. (MHz)	Average Power (dBm)		Total Power (dBm)	EIRP (dBm)	EIRP Limit (dBm)
				Ant 0	Ant 1			
11a	6Mbps	169	5845	14.02	14.18	17.11	20.71	≤ 30.00
11a	6Mbps	173	5865	13.54	13.98	16.78	20.38	≤ 30.00
11a	6Mbps	177	5885	13.25	13.44	16.36	19.96	≤ 30.00
11ac-VHT20	MCS0	169	5845	13.36	14.17	16.79	20.39	≤ 30.00
11ac-VHT20	MCS0	173	5865	13.66	13.67	16.68	20.28	≤ 30.00
11ac-VHT20	MCS0	177	5885	13.62	14.06	16.86	20.46	≤ 30.00
11ac-VHT40	MCS0	167	5835	16.85	16.33	19.61	23.21	≤ 30.00
11ac-VHT40	MCS0	175	5875	17.01	16.04	19.56	23.16	≤ 30.00
11ac-VHT80	MCS0	171	5855	18.25	18.32	21.30	24.90	≤ 30.00
11ax-HE20	MCS0	169	5845	14.41	14.29	17.36	20.96	≤ 30.00
11ax-HE20	MCS0	173	5865	14.24	13.58	16.93	20.53	≤ 30.00
11ax-HE20	MCS0	177	5885	13.81	13.88	16.86	20.46	≤ 30.00
11ax-HE40	MCS0	167	5835	16.71	16.75	19.74	23.34	≤ 30.00
11ax-HE40	MCS0	175	5875	16.77	15.80	19.32	22.92	≤ 30.00
11ax-HE80	MCS0	171	5855	18.00	18.37	21.20	24.80	≤ 30.00

Note 1: Total Average Power (dBm) =  $10 \cdot \log \{10^{(\text{Ant 0 Average Power} / 10)} + 10^{(\text{Ant 1 Average Power} / 10)}\}$ .

Note 2: EIRP Power (dBm) = Total Average Power (dBm) + Uncorrelated Directional Gain (dBi).



**A.5 Power Spectral Density Test Result**

Test Site	WZ-SR5	Test Engineer	Luis Yang
Test Date	2023-07-03~2023-08-08		

Test Mode	Data Rate/MCS	Channel No.	Freq. (MHz)	AVPSD (dBm/MHz)		Duty Cycle (%)	Total PSD (dBm/MHz)	EIRP PSD (dBm/MHz)	EIRP PSD Limit (dBm/MHz)
				Ant 0	Ant 1				
11a	6Mbps	169	5845	3.042	3.197	99.05	6.13	12.33	≤ 14.00
11a	6Mbps	173	5865	3.067	3.219	99.05	6.15	12.35	≤ 14.00
11a	6Mbps	177	5885	2.877	3.170	99.05	6.04	12.24	≤ 14.00
11ac-VHT20	MCS0	169	5845	3.104	3.237	99.03	6.18	12.38	≤ 14.00
11ac-VHT20	MCS0	173	5865	2.868	3.378	99.03	6.14	12.34	≤ 14.00
11ac-VHT20	MCS0	177	5885	2.705	3.385	99.03	6.07	12.27	≤ 14.00
11ac-VHT40	MCS0	167	5835	3.586	3.140	98.99	6.38	12.58	≤ 14.00
11ac-VHT40	MCS0	175	5875	3.231	3.100	98.99	6.18	12.38	≤ 14.00
11ac-VHT80	MCS0	171	5855	1.417	2.214	98.76	4.84	11.04	≤ 14.00
11ax-HE20	MCS0	169	5845	3.242	3.330	99.03	6.30	12.50	≤ 14.00
11ax-HE20	MCS0	173	5865	2.607	3.537	99.03	6.11	12.31	≤ 14.00
11ax-HE20	MCS0	177	5885	2.717	3.037	99.03	5.89	12.09	≤ 14.00
11ax-HE40	MCS0	167	5835	2.929	3.360	99.03	6.16	12.36	≤ 14.00
11ax-HE40	MCS0	175	5875	3.110	3.172	99.03	6.15	12.35	≤ 14.00
11ax-HE80	MCS0	171	5855	1.442	2.085	98.77	4.79	10.99	≤ 14.00

Note 1: The total PSD (dBm/MHz) =  $10 \cdot \log \{ 10^{(\text{Ant 0 AVG PSD}/10)} + 10^{(\text{Ant 1 AVG PSD}/10)} \}$ .

Note 2: EIRP PSD (dBm/MHz) = Total PSD (dBm/MHz) + Correlated Directional Gain (dBi).

Note 3: For Channels span the 5.725-5.850 GHz and 5.850-5.895 GHz bands, we record the maximum level of 5.725-5.850 GHz and 5.850-5.895 GHz with RBW=1MHz, and the level complied with the 5.850-5.895 GHz EIRP PSD Limit.

802.11a Power Spectral Density - Ant 0

Channel 169 (5845MHz)



Channel 173 (5865MHz)

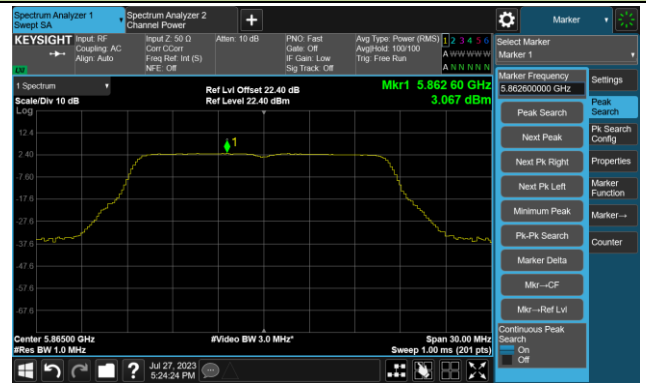

Channel 177 (5885MHz)

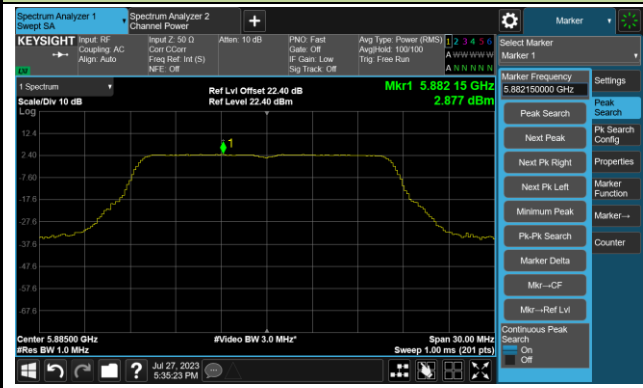

802.11ac-VHT20 Power Spectral Density - Ant 0

Channel 169 (5845MHz)

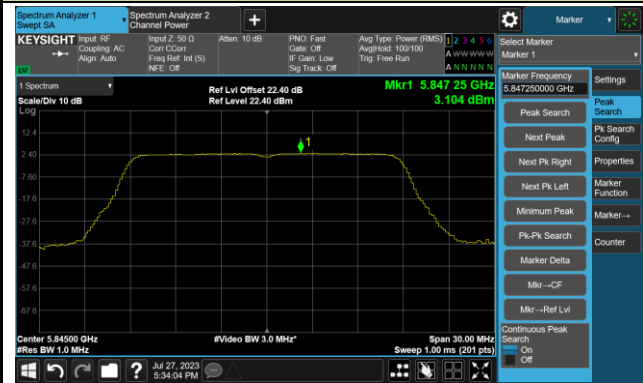

Channel 173 (5865MHz)



Channel 177 (5885MHz)

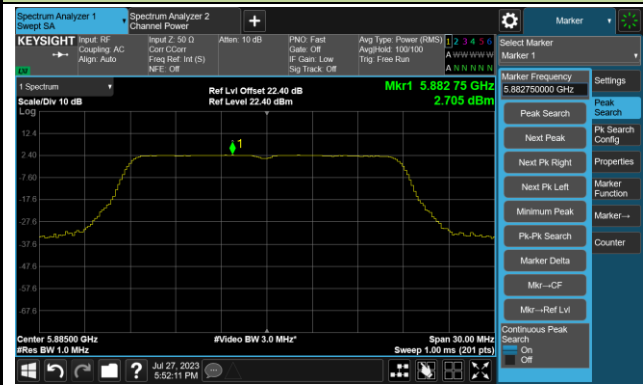

802.11ac-VHT40 Power Spectral Density - Ant 0

Channel 167 (5835MHz)

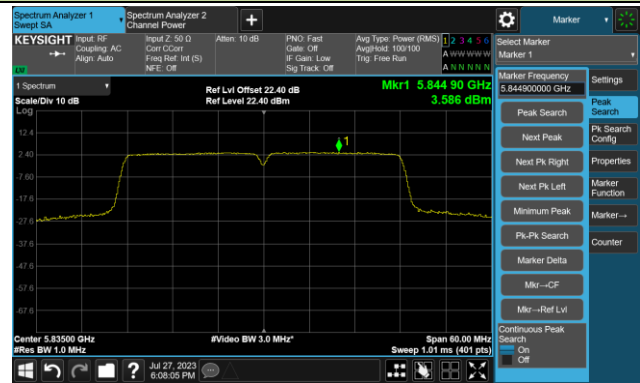

Channel 175 (5875MHz)

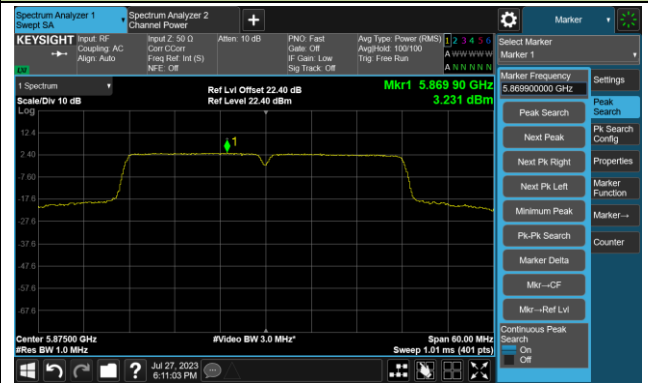

802.11ac-VHT80 Power Spectral Density - Ant 0

Channel 171 (5855MHz)



802.11ax-HE20 Power Spectral Density - Ant 0

Channel 169 (5845MHz)

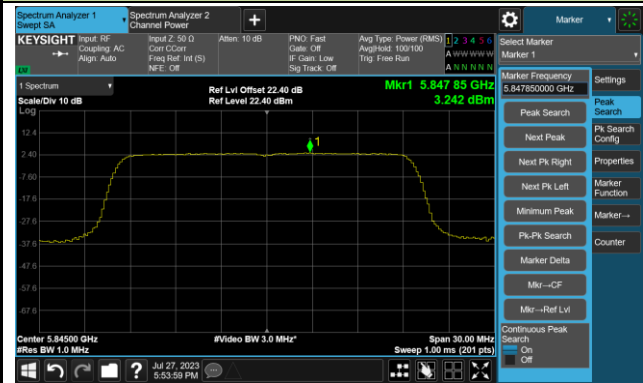

Channel 173 (5865MHz)

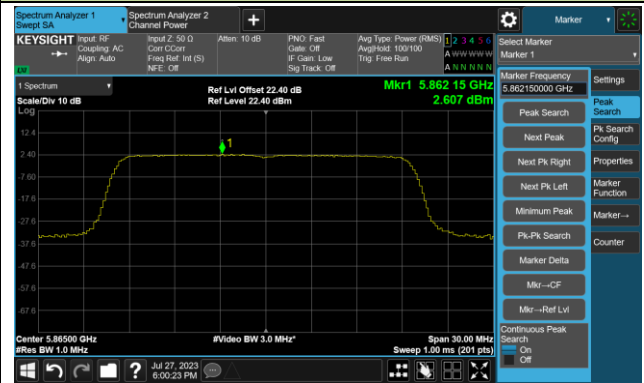

Channel 177 (5885MHz)



802.11 ax-HE40 Power Spectral Density - Ant 0

Channel 167 (5835MHz)

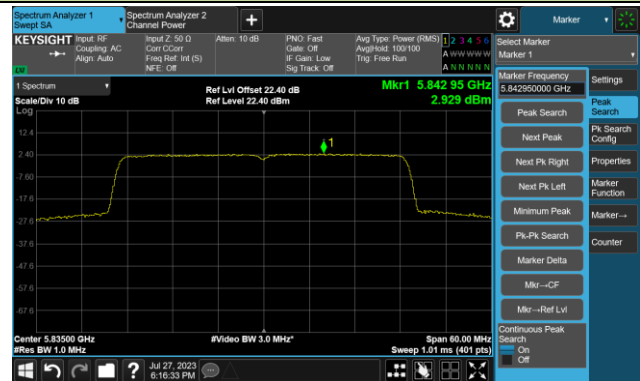

Channel 175 (5875MHz)

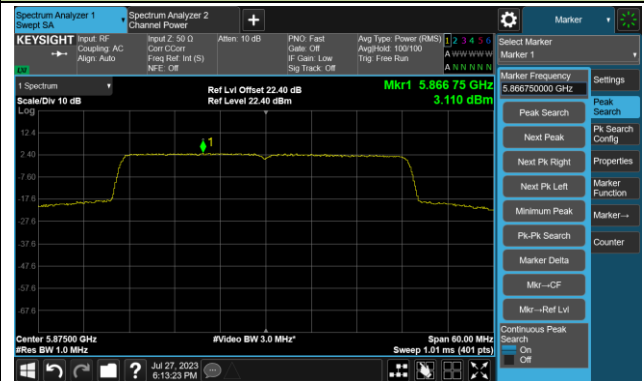

802.11 ax-HE80 Power Spectral Density - Ant 0

Channel 171 (5855MHz)



802.11a Power Spectral Density - Ant 1

Channel 169 (5845MHz)

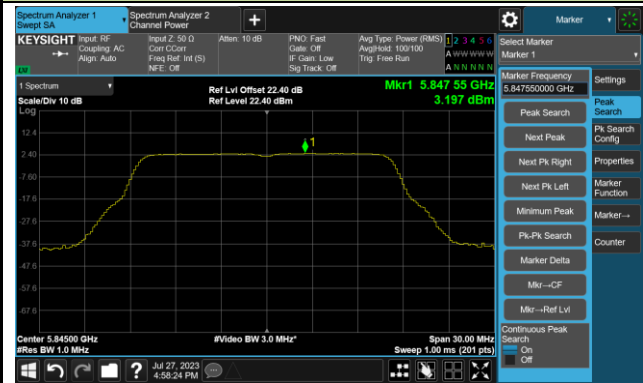

Channel 173 (5865MHz)



Channel 177 (5885MHz)

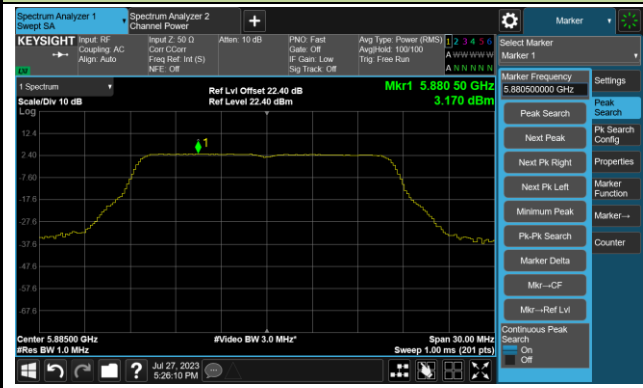

802.11ac-VHT20 Power Spectral Density - Ant 1

Channel 169 (5845MHz)

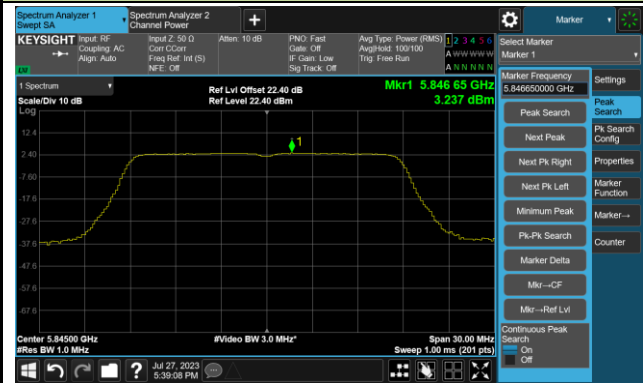

Channel 173 (5865MHz)

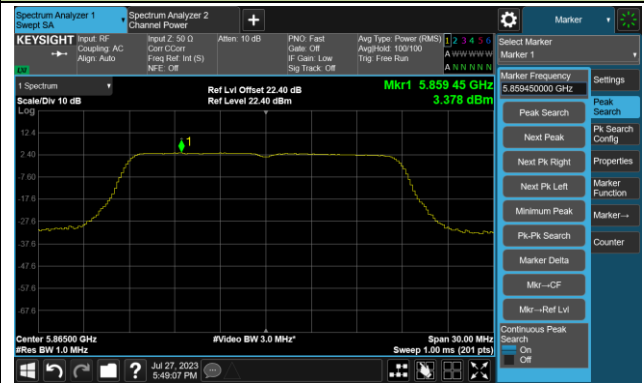

Channel 177 (5885MHz)

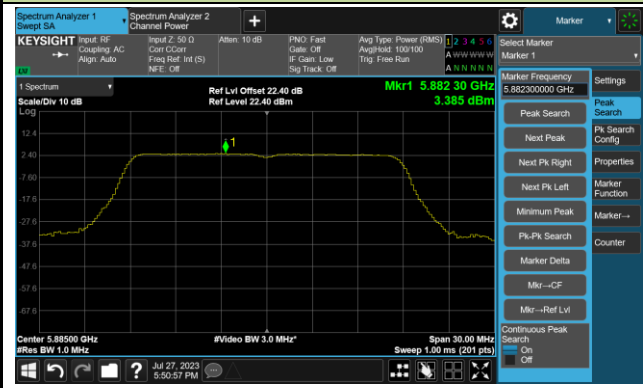



802.11ac-VHT40 Power Spectral Density - Ant 1

Channel 167 (5835MHz)

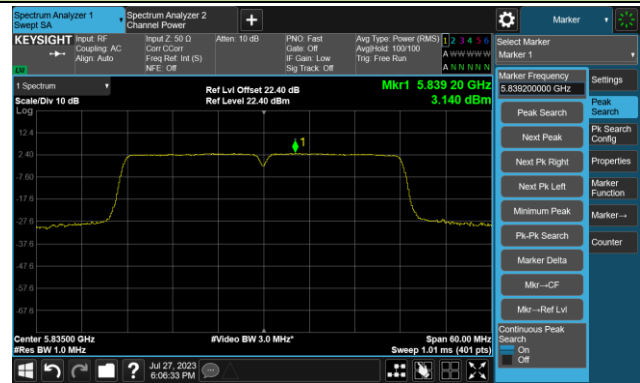

Channel 175 (5875MHz)

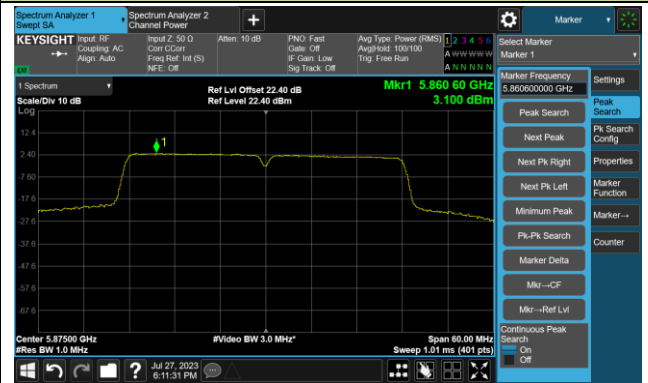

802.11ac-VHT80 Power Spectral Density - Ant 1

Channel 171 (5855MHz)



802.11ax-HE20 Power Spectral Density - Ant 1

Channel 169 (5845MHz)

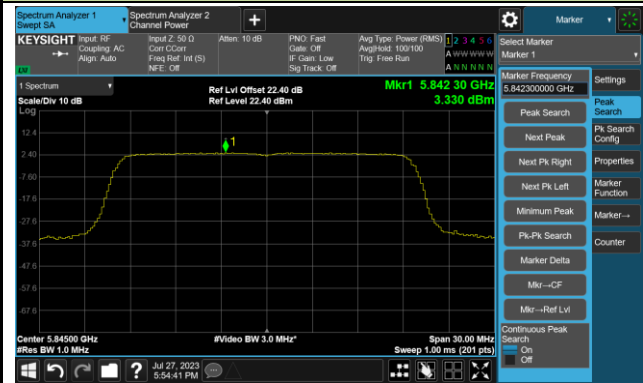

Channel 173 (5865MHz)

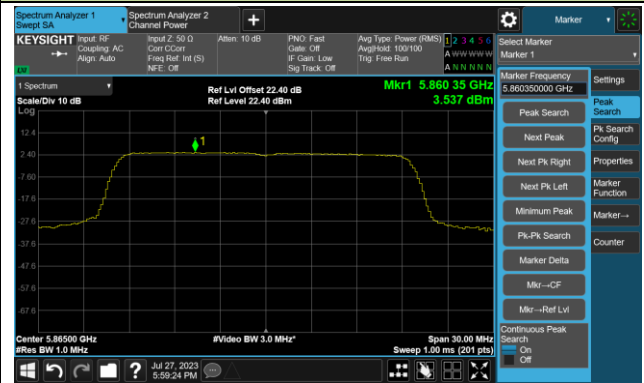

Channel 177 (5885MHz)

