

# RF MEASUREMENT REPORT

---

**FCC ID:** Q9DASIN0306  
**Applicant:** Hewlett Packard Enterprise  
**Product:** HPE Aruba User Experience Sensor  
**Model No.:** ASIN0306  
**Trademark:**  ,   
**FCC Classification:** Digital Transmission System (DTS)  
**FCC Rule Part(s):** Part 15 Subpart C (Section 15.247)  
**Result:** Complies  
**Received Date:** 2023-06-15  
**Test Date:** 2023-07-13 ~ 2023-08-13

**Reviewed By:**

\_\_\_\_\_  
Jame Yuan

**Approved By:**

\_\_\_\_\_  
Robin Wu



The test results relate only to the samples tested.  
This equipment has been shown to be capable of compliance with the applicable technical standards as indicated in the measurement report and was tested in accordance with the measurement procedures specified in ANSI C63.10-2013. Test results reported herein relate only to the item(s) tested.  
The test report shall not be reproduced except in full without the written approval of MRT Technology (Suzhou) Co., Ltd.

---

### Revision History

Report No.	Version	Description	Issue Date	Note
2306RSU027-U1	V01	Initial Report	2023-09-22	Invalid
2306RSU027-U1	V02	Add 1-18GHz test plot of RSE	2023-10-30	Valid

---

## CONTENTS

Description	Page
<b>1. General Information .....</b>	<b>5</b>
1.1. Applicant .....	5
1.2. Manufacturer .....	5
1.3. Testing Facility .....	5
1.4. Product Information.....	6
1.5. Radio Specification under Test .....	6
1.6. Working Frequencies .....	7
<b>2. Test Configuration .....</b>	<b>8</b>
2.1. Test Mode.....	8
2.2. Test System Connection Diagram.....	8
2.3. Test Software .....	9
2.4. Applied Standards.....	9
2.5. Test Environment Condition .....	9
<b>3. Antenna Requirements .....</b>	<b>10</b>
<b>4. Measuring Instrument .....</b>	<b>11</b>
<b>5. Decision Rules and Measurement Uncertainty .....</b>	<b>12</b>
5.1. Decision Rules .....	12
5.2. Measurement Uncertainty .....	12
<b>6. Test Result.....</b>	<b>13</b>
6.1. Summary.....	13
6.2. 6dB Bandwidth Measurement.....	14
6.2.1. Test Limit .....	14
6.2.2. Test Procedure.....	14
6.2.3. Test Setting .....	14
6.2.4. Test Setup .....	14
6.2.5. Test Result .....	14
6.3. Output Power Measurement .....	15
6.3.1. Test Limit .....	15
6.3.2. Test Procedure.....	15
6.3.3. Test Setting .....	15
6.3.4. Test Setup .....	15
6.3.5. Test Result .....	15
6.4. Power Spectral Density Measurement .....	16
6.4.1. Test Limit .....	16
6.4.2. Test Procedure.....	16

---

6.4.3.	Test Setting .....	16
6.4.4.	Test Setup .....	16
6.4.5.	Test Result .....	16
6.5.	Conducted Band Edge and Out-of-Band Emissions Measurement .....	17
6.5.1.	Test Limit .....	17
6.5.2.	Test Procedure .....	17
6.5.3.	Test Settintg .....	17
6.5.4.	Test Setup .....	17
6.5.5.	Test Result .....	18
6.6.	Radiated Spurious Emission Measurement.....	19
6.6.1.	Test Limit .....	19
6.6.2.	Test Procedure .....	19
6.6.3.	Test Setting .....	19
6.6.4.	Test Setup .....	21
6.6.5.	Test Result .....	22
6.7.	Radiated Restricted Band Edge Measurement .....	23
6.7.1.	Test Limit .....	23
6.7.2.	Test Procedure .....	24
6.7.3.	Test Setting .....	24
6.7.4.	Test Setup .....	25
6.7.5.	Test Result .....	25
6.8.	AC Conducted Emissions Measurement .....	26
6.8.1.	Test Limit .....	26
6.8.2.	Test Setup .....	26
6.8.3.	Test Result .....	26
<b>Appendix A - Test Result.....</b>		<b>27</b>
A.1	Duty Cycle Test Result .....	27
A.2	6dB Bandwidth Test Result .....	28
A.3	Output Power Test Result .....	30
A.4	Power Spectral Density Test Result.....	31
A.5	Conducted Band Edge and Out-of-Band Emissions Test Result.....	33
A.6	Radiated Spurious Emission Test Result.....	37
A.7	Radiated Restricted Band Edge Test Result.....	49
A.8	AC Conducted Emissions Test Result .....	65
<b>Appendix B - Test Setup Photograph .....</b>		<b>67</b>
<b>Appendix C - EUT Photograph .....</b>		<b>68</b>



#### 1.4. Product Information

Product Name	HPE Aruba User Experience Sensor
Model No.	ASIN0306
Serial No.	CNQGLPM00G
Software Version	HPE HCI V0.0.1.0
Wi-Fi Specification	802.11a/b/g/n/ac/ax
Bluetooth Specification	BLE only
ZigBee Specification	802.15.4
Power Type	AC/DC Adapter Input
Operating Temperature	0 ~ 40 °C
Operating Environment	Indoor Use
Integrated Modular Information	
Specification	Model Number: EG21-G FCC ID: XMR201906EG21G GSM 850, PCS 1900 Supported UTRA Band: 2, 4, 5 Supported E-UTRA Band: FDD Band: 2, 4, 5, 7, 12, 13, 25, 26 TDD Band: 38, 41 GNSS: GPS, BDS, GLONASS, Galileo
Accessories	
AC/DC Adapter	Model No.: WB-12G12R Input: 100-240V, 50/60Hz, 0.3A Max Output: 12.0V=1.0A 12.0W
Note: The information of EUT was provided by the manufacturer, and the accuracy of the information shall be the responsibility of the manufacturer.	

#### 1.5. Radio Specification under Test

Bluetooth Frequency	2402 ~ 2480MHz
Channel Number	40
Type of modulation	GFSK
Data Rate	1Mbps & 2Mbps
Antenna Type	PIFA Antenna
Antenna Gain	2.30dBi

**1.6. Working Frequencies**

Channel	Frequency	Channel	Frequency	Channel	Frequency
00	2402 MHz	01	2404 MHz	02	2406 MHz
03	2408 MHz	04	2410 MHz	05	2412 MHz
06	2414 MHz	07	2416 MHz	08	2418 MHz
09	2420 MHz	10	2422 MHz	11	2424 MHz
12	2426 MHz	13	2428 MHz	14	2430 MHz
15	2432 MHz	16	2434 MHz	17	2436 MHz
18	2438 MHz	19	2440 MHz	20	2442 MHz
21	2444 MHz	22	2446 MHz	23	2448 MHz
24	2450 MHz	25	2452 MHz	26	2454 MHz
27	2456 MHz	28	2458 MHz	29	2460 MHz
30	2462 MHz	31	2464 MHz	32	2466 MHz
33	2468 MHz	34	2470 MHz	35	2472 MHz
36	2474 MHz	37	2476 MHz	38	2478 MHz
39	2480 MHz	--	--	--	--

## 2. Test Configuration

### 2.1. Test Mode

Mode 1: Transmit by BLE-1Mbps
Mode 2: Transmit by BLE-2Mbps

#### Radio Working Mode

Work Groups	Wi-Fi Radio 0	Wi-Fi Radio 1	IOT
1	2.4G	6G	BLE or ZigBee
2	5G	2.4G	BLE or ZigBee
3	5G	6G	BLE or ZigBee

### 2.2. Test System Connection Diagram

The device was tested per the guidance ANSI C63.10: 2013 was used to reference the appropriate EUT setup for radiated emissions testing and AC line conducted testing.

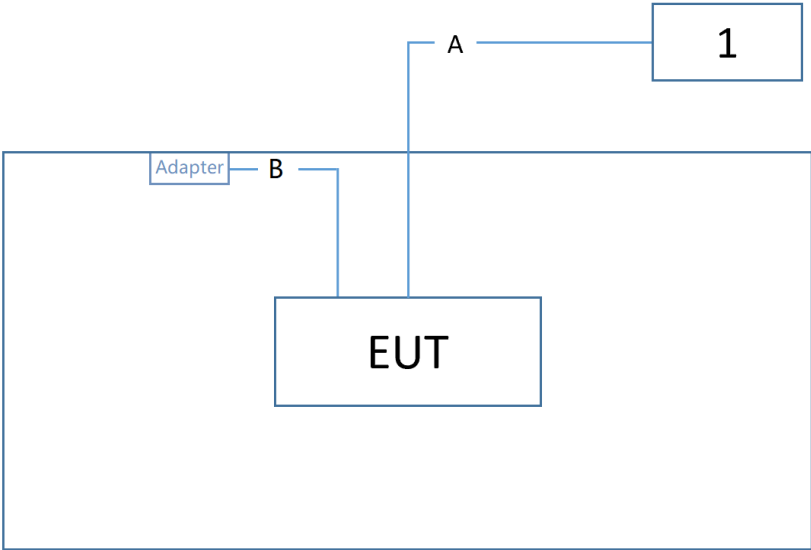
Connection Diagram – Radiated Emission testing & AC Conducted Emissions			
			
Cable Type		Cable Description	
A	Ethernet Cable	Non shielded, > 10m	
B	Power Cable	Non shielded, 1.6m	
Product		Manufacturer	Model No.
1	Notebook	Dell	Latitude 5491



### 2.3. Test Software

The test utility software used during testing was “IPOP”, and commands were provided by manufacturer.

### 2.4. Applied Standards

According to the specifications of the manufacturer, the EUT must comply with the requirements of the following standards:

- FCC Part 15.247
- KDB 558074 D01v05r02
- ANSI C63.10-2013

### 2.5. Test Environment Condition

Ambient Temperature	15 ~ 35°C
Relative Humidity	20 ~75%RH

### 3. Antenna Requirements

**Excerpt from §15.203 of the FCC Rules/Regulations:**

“An intentional radiator antenna shall be designed to ensure that no antenna other than that furnished by the responsible party can be used with the device. The use of a permanently attached antenna or of an antenna that uses a unique coupling to the intentional radiator shall be considered sufficient to comply with the provisions of this section.”

- The antenna of the device is **permanently attached**.
- There are no provisions for connection to an external antenna.

**Conclusion:**

The unit complies with the requirement of §15.203.

#### 4. Measuring Instrument

Instrument	Manufacturer	Model No.	Asset No.	Cali. Interval	Cali. Due Date	Test Site
EMI Test Receiver	R&S	ESR7	MRTSUE06001	1 year	2023-12-28	WZ-AC1
Horn Antenna	Schwarzbeck	BBHA 9120D	MRTSUE06023	1 year	2023-08-22	WZ-AC1
Preamplifier	Agilent	83017A	MRTSUE06076	1 year	2024-05-07	WZ-AC1
TRILOG Antenna	Schwarzbeck	VULB 9168	MRTSUE06172	1 year	2024-06-09	WZ-AC1
Anechoic Chamber	TDK	WZ-AC1	MRTSUE06212	1 year	2024-04-20	WZ-AC1
Thermohygrometer	testo	608-H1	MRTSUE06403	1 year	2024-05-31	WZ-AC1
Signal Analyzer	Keysight	N9010B	MRTSUE06607	1 year	2023-12-28	WZ-AC1
Thermohygrometer	testo	608-H1	MRTSUE11039	1 year	2023-11-01	WZ-AC1
Loop Antenna	Schwarzbeck	FMZB 1519	MRTSUE06025	1 year	2023-09-29	WZ-AC1
Horn Antenna	Schwarzbeck	BBHA 9170	MRTSUE06597	1 year	2023-11-05	WZ-AC2
Preamplifier	EMCI	EMC184045SE	MRTSUE06640	1 year	2024-01-12	WZ-AC2
TRILOG Antenna	Schwarzbeck	VULB 9162	MRTSUE06022	1 year	2024-05-15	WZ-AC2
EMI Test Receiver	Agilent	N9038A	MRTSUE06125	1 year	2024-05-23	WZ-AC2
Thermohygrometer	Mingle	ETH529	MRTSUE06170	1 year	2023-11-27	WZ-AC2
Horn Antenna	Schwarzbeck	BBHA 9120D	MRTSUE06171	1 year	2023-10-13	WZ-AC2
Preamplifier	Schwarzbeck	BBV 9718	MRTSUE06176	1 year	2024-05-07	WZ-AC2
Anechoic Chamber	RIKEN	WZ-AC2	MRTSUE06213	1 year	2024-04-20	WZ-AC2
Thermohygrometer	testo	608-H1	MRTSUE11038	1 year	2023-11-01	WZ-AC2
Two-Line V-Network	R&S	ENV216	MRTSUE06002	1 year	2024-05-23	WZ-SR2
Shielding Room	MIX-BEP	WZ-SR2	MRTSUE06215	5 years	2026-12-20	WZ-SR2
Thermohygrometer	testo	608-H1	MRTSUE06404	1 year	2024-05-31	WZ-SR2
Four-Line V-Network	R&S	ENV432	MRTSUE06615	1 year	2023-10-08	WZ-SR2
EMI Test Receiver	R&S	ESR3	MRTSUE06909	1 year	2023-10-27	WZ-SR2
Thermohygrometer	testo	608-H1	MRTSUE06402	1 year	2024-05-31	WZ-SR5
Shielding Room	HUAMING	WZ-SR5	MRTSUE06442	N/A	N/A	WZ-SR5
Signal Analyzer	Keysight	N9010B	MRTSUE06457	1 year	2024-05-23	WZ-SR5
USB Power Sensor	Keysight	U2021XA	MRTSUE06446	1 year	2024-05-23	WZ-SR5

Software	Version	Function
EMI Software	V3.0.0	EMI Test Software
Controller_MF 7802	2.03C	RE Antenna & Turntable
Controller_MF 7802	1.02	RE Antenna & Turntable
BenchVue Power Meter	2018.1	Power

## 5. Decision Rules and Measurement Uncertainty

### 5.1. Decision Rules

The Decision Rule is based on Simple Acceptance in accordance with ISO Guide 98-4: 2012 Clause 8.2. (Measurement uncertainty is not taken into account when stating conformity with a specified requirement.)

### 5.2. Measurement Uncertainty

Where relevant, the following test uncertainty levels have been estimated for tests performed on the EUT as specified in CISPR 16-4-2. This uncertainty represents an expanded uncertainty expressed at approximately the 95% confidence level using a coverage factor of  $k = 2$ .

<b>AC Conducted Emission Measurement</b>
Measurement Uncertainty for a Level of Confidence of 95% ( $U=2Uc(y)$ ): 9kHz~150kHz: 3.58dB 150kHz~30MHz: 3.20dB
<b>Radiated Disturbance</b>
Measurement Uncertainty for a Level of Confidence of 95% ( $U=2Uc(y)$ ): Coaxial: 9kHz~30MHz: 2.59dB Coplanar: 9kHz~30MHz: 2.60dB Horizontal: 30MHz~200MHz: 3.85dB 200MHz~1GHz: 4.36dB 1GHz~40GHz: 4.98dB Vertical: 30MHz~200MHz: 4.06dB 200MHz~1GHz: 5.28dB 1GHz~40GHz: 4.91dB
<b>Spurious Emissions, Conducted</b>
Measuring Uncertainty for a Level of Confidence of 95% ( $U=2Uc(y)$ ): 2.3dB
<b>Output Power</b>
Measuring Uncertainty for a Level of Confidence of 95% ( $U=2Uc(y)$ ): 1.5dB
<b>Power Spectrum Density</b>
Measuring Uncertainty for a Level of Confidence of 95% ( $U=2Uc(y)$ ): 2.3dB
<b>Occupied Bandwidth</b>
Measuring Uncertainty for a Level of Confidence of 95% ( $U=2Uc(y)$ ): 3.2%

## 6. Test Result

### 6.1. Summary

FCC Section(s)	Test Description	Test Condition	Verdict
15.247(a)(2)	6dB Bandwidth	Conducted	Pass
15.247(b)(3)	Output Power		Pass
15.247(e)	Power Spectral Density		Pass
15.247(d)	Band Edge / Out-of-Band Emissions		Pass
15.205 15.209	General Field Strength (Restricted Bands and Radiated Emission)	Radiated	Pass
15.207	AC Conducted Emissions 150kHz - 30MHz	Line Conducted	Pass

#### Notes:

1. The analyzer plots shown in this section were all taken with a correction table loaded into the analyzer. The correction table was used to account for the losses of the cables and attenuators used as part of the system to connect the EUT to the analyzer at all frequencies of interest.
2. All modes of operation and data rates were investigated. For radiated emission test, every axis (X, Y, Z) was also verified. The test results shown in the following sections represent the worst-case emissions.

## 6.2. 6dB Bandwidth Measurement

### 6.2.1. Test Limit

The minimum 6dB bandwidth shall be at least 500 kHz.

### 6.2.2. Test Procedure

ANSI C63.10 - 2013 - Section 11.8

### 6.2.3. Test Setting

1. The Spectrum's automatic bandwidth measurement capability was used to perform the 6dB bandwidth measurement. The "X" dB bandwidth parameter was set to  $X = 6$ . The bandwidth measurement was not influenced by any intermediate power nulls in the fundamental emission.
2. Set RBW = 100 kHz
3. VBW  $\geq 3 \times$  RBW
4. Detector = Peak
5. Trace mode = Max hold
6. Sweep = Auto couple
7. Allow the trace to stabilize

### 6.2.4. Test Setup

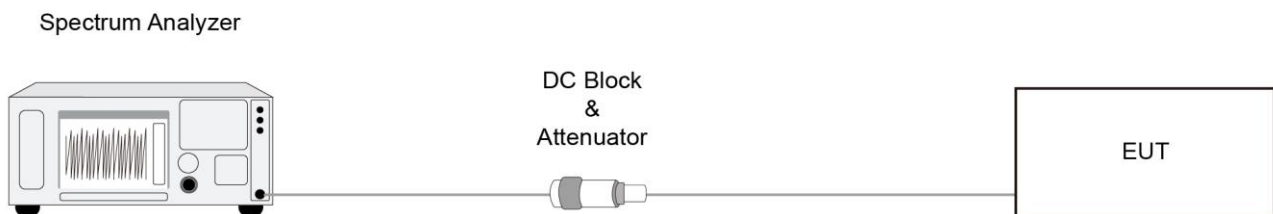

### 6.2.5. Test Result

Refer to Appendix A.2.

### 6.3. Output Power Measurement

#### 6.3.1. Test Limit

The maximum output power shall be less 1 Watt (30dBm).

The conducted output power limit specified in paragraph FCC Part 15.247(b) of this section is based on the use of antennas with directional gains that do not exceed 6 dBi. If transmitting antennas of directional gain greater than 6 dBi are used, the conducted output power from the intentional radiator shall be reduced below the stated values in paragraphs FCC Part 15.247(b)(3) of this section, as appropriate, by the amount in dB that the directional gain of the antenna exceeds 6 dBi.

#### 6.3.2. Test Procedure

ANSI C63.10 - 2013 - Section 11.9.1.3

ANSI C63.10 - 2013 - Section 11.9.2.3.2

#### 6.3.3. Test Setting

##### **Method PKPM1 (Peak Power Measurement of Signals with DTS BW $\leq$ 50MHz)**

Peak power measurements were performed only when the EUT was transmitting at its maximum power control level using a broadband power meter with a pulse sensor. The pulse sensor employs a VBW = 50MHz so this method was only used for signals whose DTS bandwidth was less than or equal to 50MHz.

##### **Average Power Measurement**

Average power measurements were performed only when the EUT was transmitting at its maximum power control level using a broadband power meter with a pulse sensor. The power meter implemented triggering and gating capabilities which were set up such that power measurements were recorded only during the ON time of the transmitter.

#### 6.3.4. Test Setup

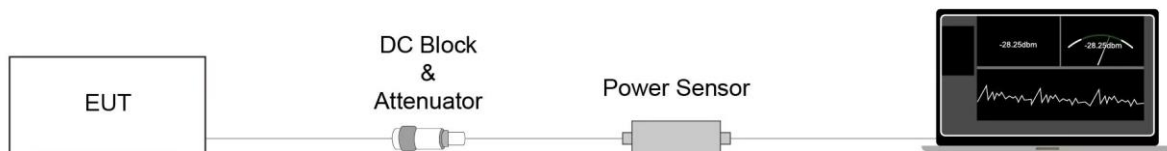

#### 6.3.5. Test Result

Refer to Appendix A.3.

## 6.4. Power Spectral Density Measurement

### 6.4.1. Test Limit

The maximum permissible power spectral density is 8dBm in any 3 kHz band.

The same method of determining the conducted output power shall be used to determine the power spectral density.

### 6.4.2. Test Procedure

ANSI C63.10-2013 Section 11.10.2

### 6.4.3. Test Setting

1. Analyzer was set to the center frequency of the DTS channel under investigation
2. Span = 1.5 times the DTS channel bandwidth
3. RBW = 3kHz
4. VBW = 10kHz
5. Detector = peak
6. Sweep time = auto couple
7. Trace mode = max hold
8. Trace was allowed to stabilize

### 6.4.4. Test Setup

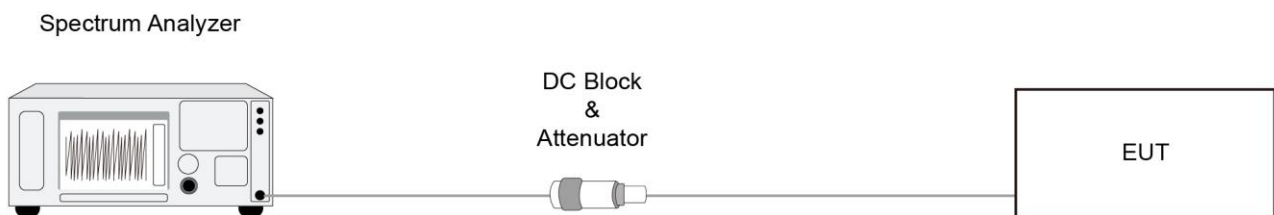

### 6.4.5. Test Result

Refer to Appendix A.4.



## 6.5. Conducted Band Edge and Out-of-Band Emissions Measurement

### 6.5.1. Test Limit

The limit for out-of-band spurious emissions at the band edge is 20dB below the fundamental emission level, as determined from the in-band power measurement of the DTS channel performed in a 100 kHz bandwidth per the PSD procedure.

### 6.5.2. Test Procedure

ANSI C63.10-2013 - Section 11.11

### 6.5.3. Test Setting

#### Reference level measurement

1. Set instrument center frequency to DTS channel center frequency
2. Set the span to  $\geq 1.5$  times the DTS bandwidth
3. Set the RBW = 100 kHz
4. Set the VBW  $\geq 3 \times$  RBW
5. Detector = peak
6. Sweep time = auto couple
7. Trace mode = max hold
8. Allow trace to fully stabilize

#### Emission level measurement

1. Set the center frequency and span to encompass frequency range to be measured
2. RBW = 100kHz
3. VBW = 300kHz
4. Detector = Peak
5. Trace mode = max hold
6. Sweep time = auto couple
7. The trace was allowed to stabilize

### 6.5.4. Test Setup

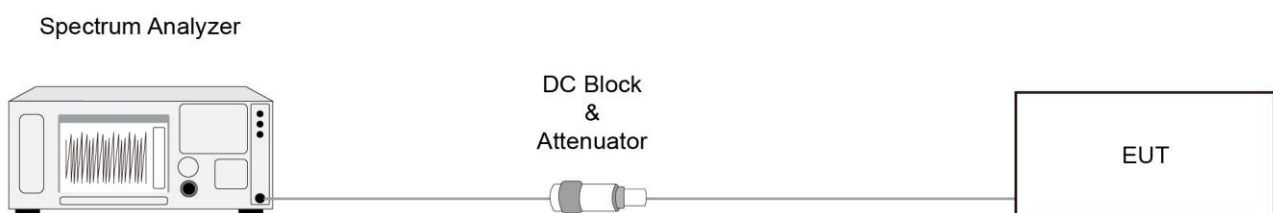

### **6.5.5. Test Result**

Refer to Appendix A.5.

## 6.6. Radiated Spurious Emission Measurement

### 6.6.1. Test Limit

All out of band emissions appearing in a restricted band as specified in Section 15.205 of the Title 47 CFR must not exceed the limits shown in Table per Section 15.209.

FCC Part 15 Subpart C Paragraph 15.209		
Frequency [MHz]	Field Strength [ $\mu\text{V/m}$ ]	Measured Distance [Meters]
0.009 - 0.490	2400/F (kHz)	300
0.490 - 1.705	24000/F (kHz)	30
1.705 - 30	30	30
30 - 88	100	3
88 - 216	150	3
216 - 960	200	3
Above 960	500	3

### 6.6.2. Test Procedure

ANSI C63.10 - 2013 - Section 11.11 & 11.12

ANSI C63.10 - 2013 - Section 6.3 (General Requirements)

ANSI C63.10 - 2013 - Section 6.4 (Standard test method below 30MHz)

ANSI C63.10 - 2013 - Section 6.5 (Standard test method above 30MHz to 1GHz)

ANSI C63.10 - 2013 - Section 6.6 (Standard test method above 1GHz)

### 6.6.3. Test Setting

**Table 1 - RBW as a function of frequency**

Frequency	RBW
9 ~ 150 kHz	200 ~ 300 Hz
0.15 ~ 30 MHz	9 ~ 10 kHz
30 ~ 1000 MHz	100 ~ 120 kHz
> 1000MHz	1MHz

**Quasi-Peak Measurements below 1GHz**

1. Analyzer center frequency was set to the frequency of the radiated spurious emission of interest
2. Span was set greater than 1MHz
3. RBW = as specified in Table 1
4. Detector = CISPR quasi-peak
5. Sweep time = auto couple
6. Trace was allowed to stabilize

**Peak Measurements above 1GHz**

1. Analyzer center frequency was set to the frequency of the radiated spurious emission of interest
2. RBW = 1MHz
3. VBW = 3MHz
4. Detector = peak
5. Sweep time = auto couple
6. Trace mode = max hold
7. Trace was allowed to stabilize

**Average Measurements above 1GHz (Method VB)**

1. Analyzer center frequency was set to the frequency of the radiated spurious emission of interest
2. RBW = 1MHz
3. VBW; If the EUT is configured to transmit with duty cycle  $\geq 98\%$ , set VBW = 10 Hz.  
If the EUT duty cycle is  $< 98\%$ , set VBW  $\geq 1/T$ . T is the minimum transmission duration.

BLE 1Mbps	2.7kHz	BLE 2Mbps	5.1kHz	--	--
-----------	--------	-----------	--------	----	----

4. Detector = Peak
5. Sweep time = auto
6. Trace mode = max hold
7. Trace was allowed to stabilize

### 6.6.4. Test Setup

Below 30MHz Test Setup:

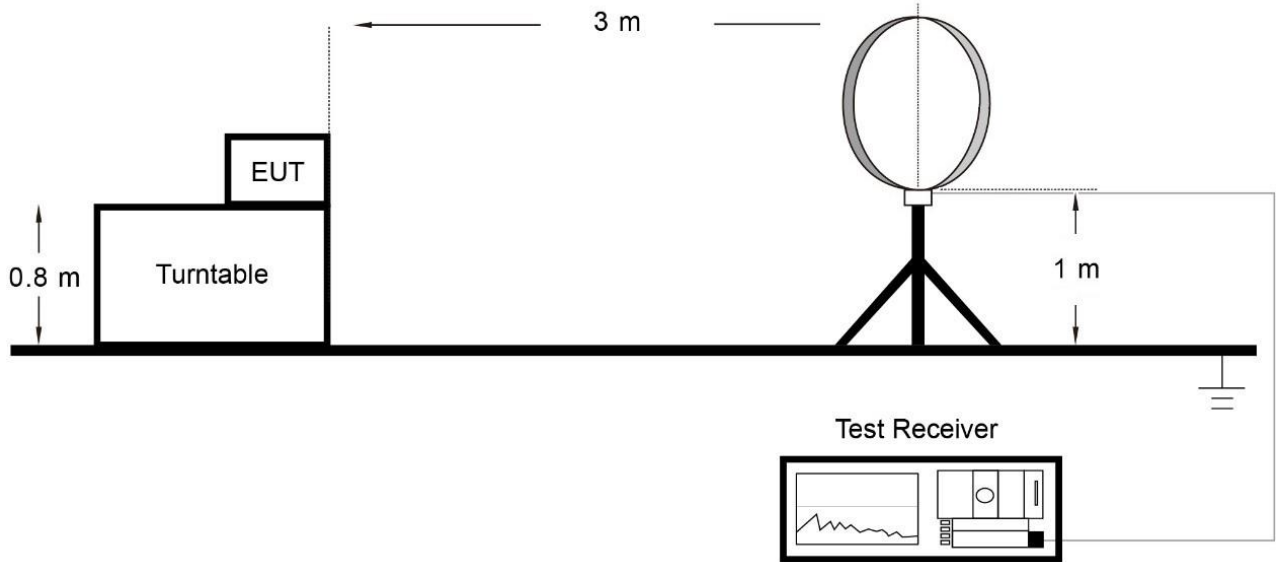

Below 1GHz Test Setup:

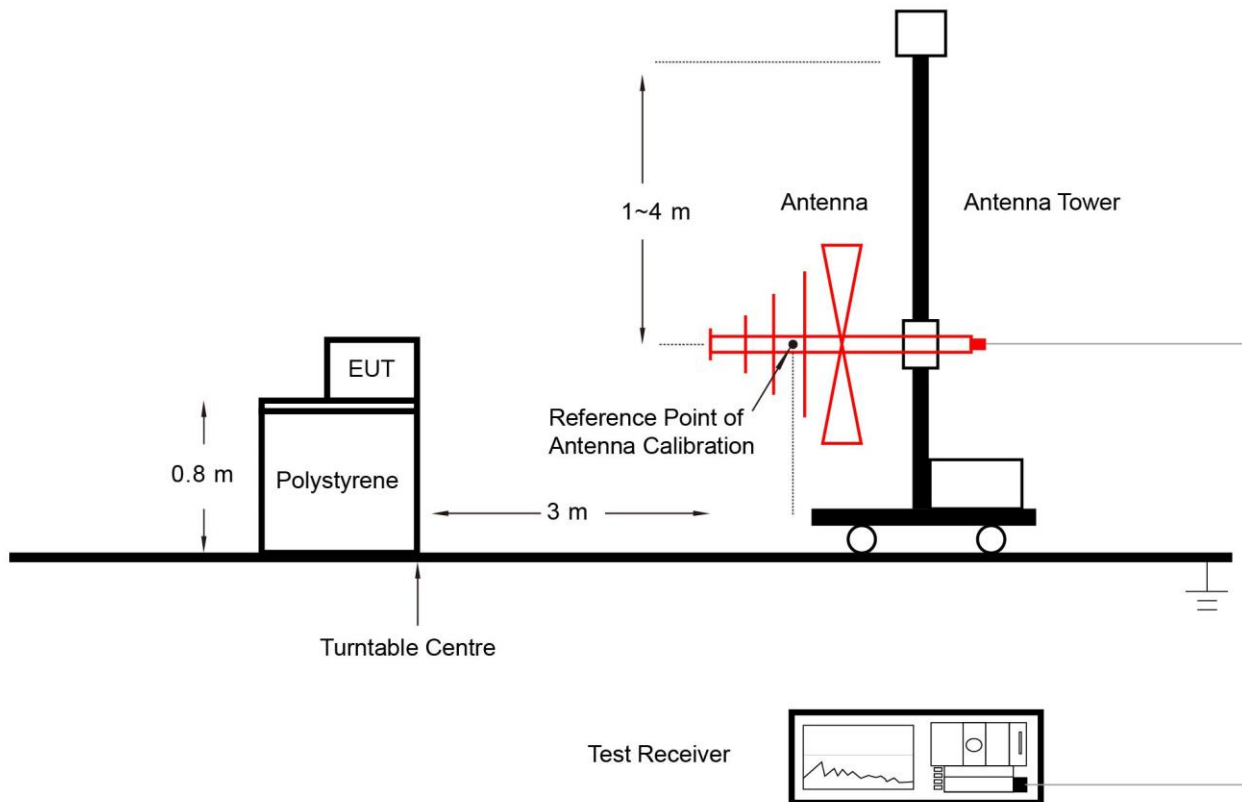

Above 1GHz Test Setup:

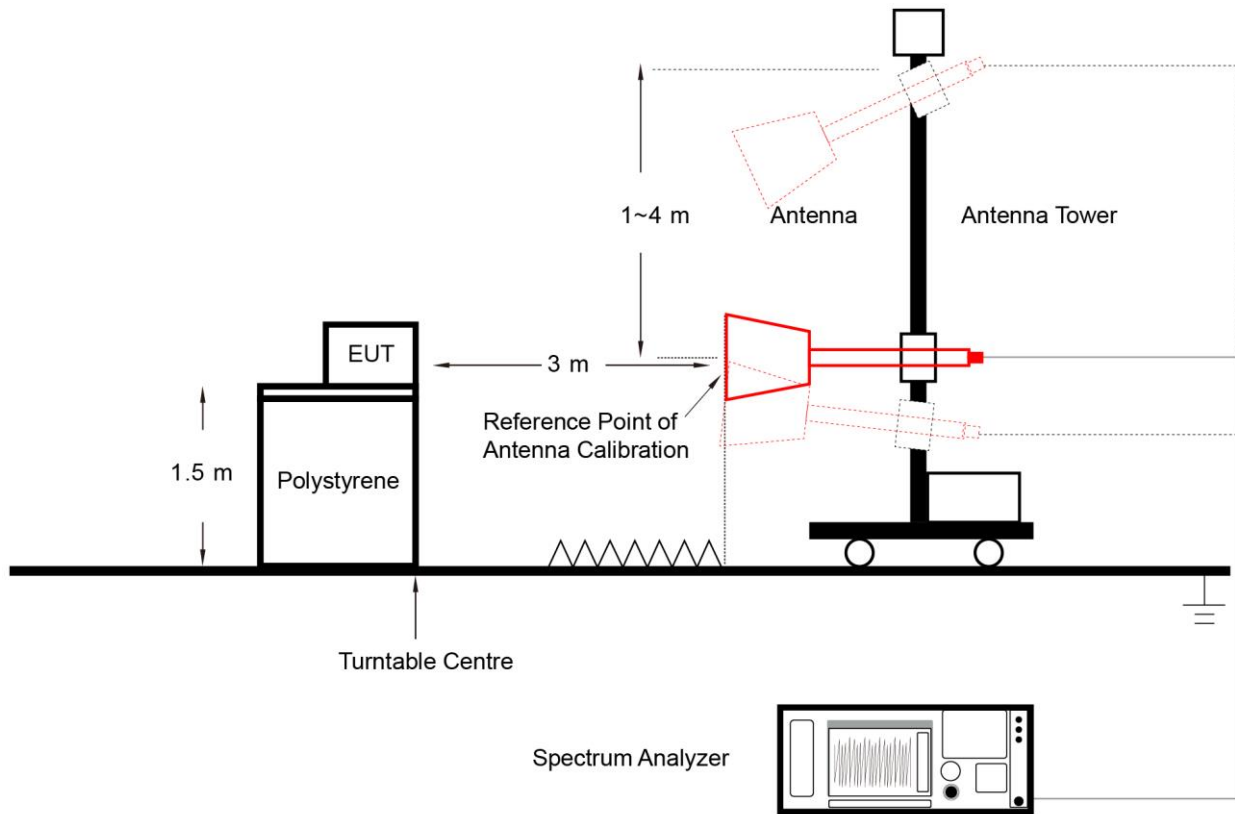

6.6.5. Test Result

Refer to Appendix A.6.

## 6.7. Radiated Restricted Band Edge Measurement

### 6.7.1. Test Limit

#### For 15.205 requirement:

Radiated emissions which fall in the restricted bands, as defined in Section 15.205(a) of FCC part 15, must also comply with the radiated emission limits specified in Section 15.209(a).

Frequency (MHz)	Frequency (MHz)	Frequency (MHz)	Frequency (GHz)
0.090 - 0.110	16.42 - 16.423	399.9 - 410	4.5 - 5.15
<sup>1</sup> 0.495 - 0.505	16.69475 - 16.69525	608 - 614	5.35 - 5.46
2.1735 - 2.1905	16.80425 - 16.80475	960 - 1240	7.25 - 7.75
4.125 - 4.128	25.5 - 25.67	1300 - 1427	8.025 - 8.5
4.17725 - 4.17775	37.5 - 38.25	1435 - 1626.5	9.0 - 9.2
4.20725 - 4.20775	73 - 74.6	1645.5 - 1646.5	9.3 - 9.5
6.215 - 6.218	74.8 - 75.2	1660 - 1710	10.6 - 12.7
6.26775 - 6.26825	108 - 121.94	1718.8 - 1722.2	13.25 - 13.4
6.31175 - 6.31225	123 - 138	2200 - 2300	14.47 - 14.5
8.291 - 8.294	149.9 - 150.05	2310 - 2390	15.35 - 16.2
8.362 - 8.366	156.52475 - 156.52525	2483.5 - 2500	17.7 - 21.4
8.37625 - 8.38675	156.7 - 156.9	2690 - 2900	22.01 - 23.12
8.41425 - 8.41475	162.0125 - 167.17	3260 - 3267	23.6 - 24.0
12.29 - 12.293	167.72 - 173.2	3332 - 3339	31.2 - 31.8
12.51975 - 12.52025	240 - 285	3345.8 - 3358	36.43 - 36.5
12.57675 - 12.57725	322 - 335.4	3600 - 4400	( <sup>2</sup> )
13.36 - 13.41	--	--	--

All out of band emissions appearing in a restricted band as specified in Section 15.205 of the Title 47CFR must not exceed the limits shown in Table per Section 15.209.

FCC Part 15 Subpart C Paragraph 15.209		
Frequency [MHz]	Field Strength [ $\mu\text{V/m}$ ]	Measured Distance [Meters]
0.009 - 0.490	2400/F (kHz)	300
0.490 - 1.705	24000/F (kHz)	30
1.705 - 30	30	30
30 - 88	100	3
88 - 216	150	3
216 - 960	200	3
Above 960	500	3

### 6.7.2. Test Procedure

ANSI C63.10-2013 Section 6.3 & 6.6 & 11.13

### 6.7.3. Test Setting

#### Peak Field Strength Measurements

1. Analyzer center frequency was set to the frequency of the radiated spurious emission of interest
2. RBW = 1MHz
3. VBW = 3MHz
4. Detector = peak
5. Sweep time = auto couple
6. Trace mode = max hold
7. Trace was allowed to stabilize

#### Average Field Strength Measurements

1. Analyzer center frequency was set to the frequency of the radiated spurious emission of interest
2. RBW = 1MHz
3. VBW; If the EUT is configured to transmit with duty cycle  $\geq 98\%$ , set VBW = 10 Hz.

If the EUT duty cycle is  $< 98\%$ , set VBW  $\geq 1/T$ . T is the minimum transmission duration.

BLE 1Mbps	2.7kHz	BLE 2Mbps	5.1kHz	--	--
-----------	--------	-----------	--------	----	----

4. As an alternative, the instrument may be set to linear detector mode. Ensure that video filtering is applied in linear voltage domain (rather than in a log or dB domain). Some instruments require linear display mode in order to accomplish this. Others have a setting for Average-VBW Type, which can be set to



“Voltage” regardless of the display mode

5. Detector = Peak
6. Sweep time = auto
7. Trace mode = max hold
8. Allow max hold to run for at least 50 times (1/duty cycle) traces

#### 6.7.4. Test Setup

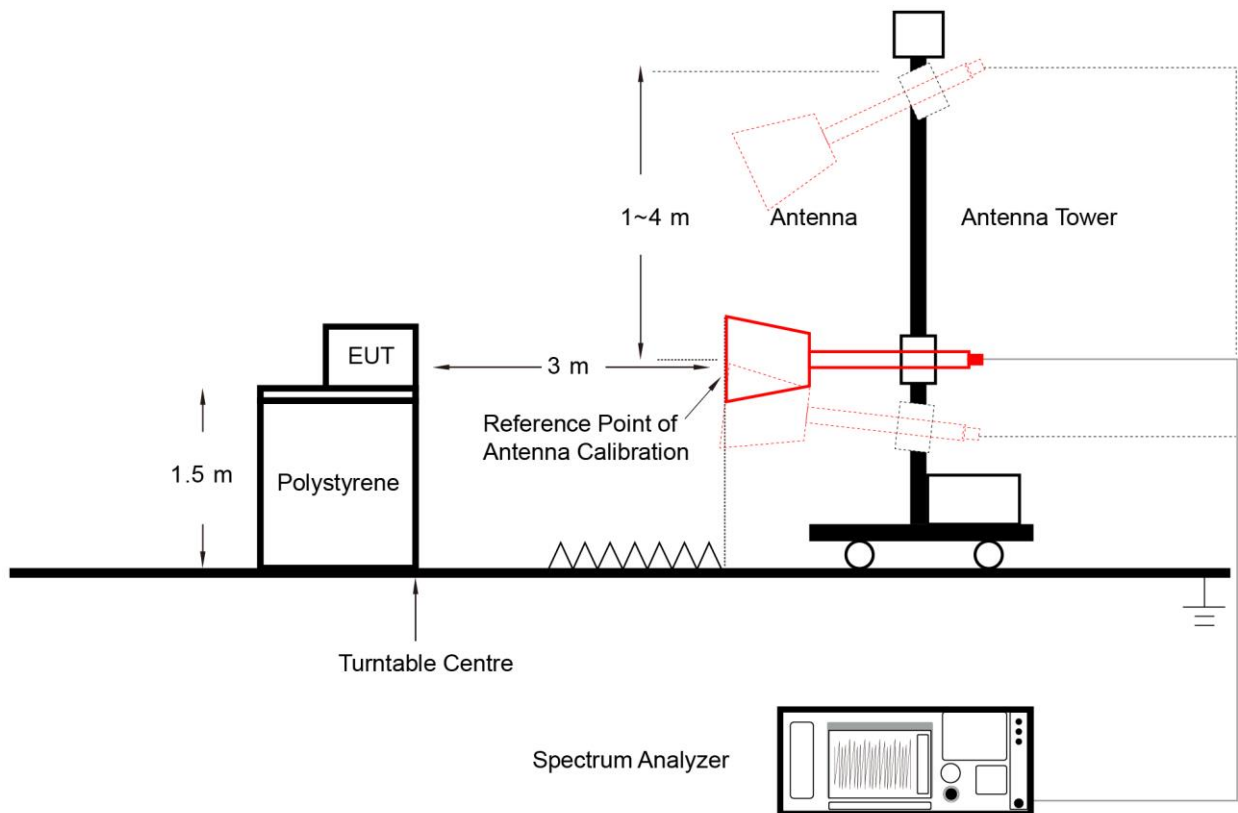

#### 6.7.5. Test Result

Refer to Appendix A.7.

## 6.8. AC Conducted Emissions Measurement

### 6.8.1. Test Limit

FCC Part 15 Subpart C Paragraph 15.207 Limits		
Frequency (MHz)	QP (dB $\mu$ V)	AV (dB $\mu$ V)
0.15 - 0.50	66 - 56	56 - 46
0.50 - 5.0	56	46
5.0 - 30	60	50

Note 1: The lower limit shall apply at the transition frequencies.

Note 2: The limit decreases linearly with the logarithm of the frequency in the range 0.15MHz to 0.5MHz.

### 6.8.2. Test Setup

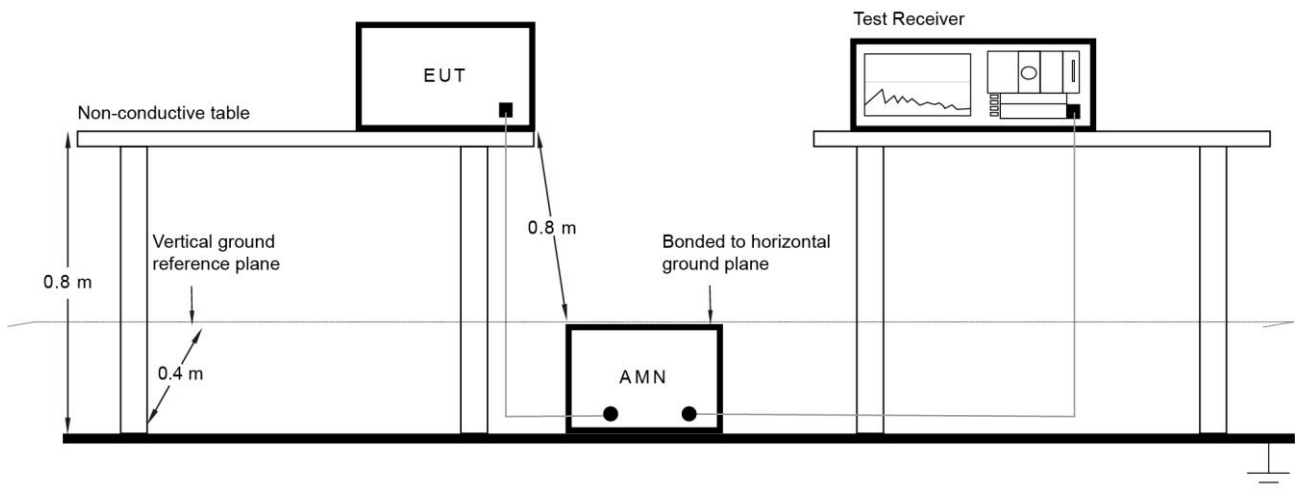

### 6.8.3. Test Result

Refer to Appendix A.8.

## Appendix A - Test Result

### A.1 Duty Cycle Test Result

Test Site	WZ-SR5	Test Engineer	Lynn Yang
Test Date	2023-07-13		

Test Mode	Duty Cycle
BLE-1Mbps	62.74%
BLE-2Mbps	33.09%
Duty Cycle (T = Transmission Duration)	
BLE-1Mbps (T = 392.5 $\mu$ s)	BLE-2Mbps (T = 207.0 $\mu$ s)

**A.2 6dB Bandwidth Test Result**

Test Site	WZ-SR5	Test Engineer	Lynn Yang
Test Date	2023-07-13		

Test Mode	Data Rate	Channel No.	Frequency (MHz)	6dB Bandwidth (MHz)	Limit (MHz)
BLE	1Mbps	00	2402	0.7042	≥ 0.5
BLE	1Mbps	19	2440	0.7052	≥ 0.5
BLE	1Mbps	39	2480	0.7025	≥ 0.5
BLE	2Mbps	00	2402	1.161	≥ 0.5
BLE	2Mbps	19	2440	1.167	≥ 0.5
BLE	2Mbps	39	2480	1.156	≥ 0.5

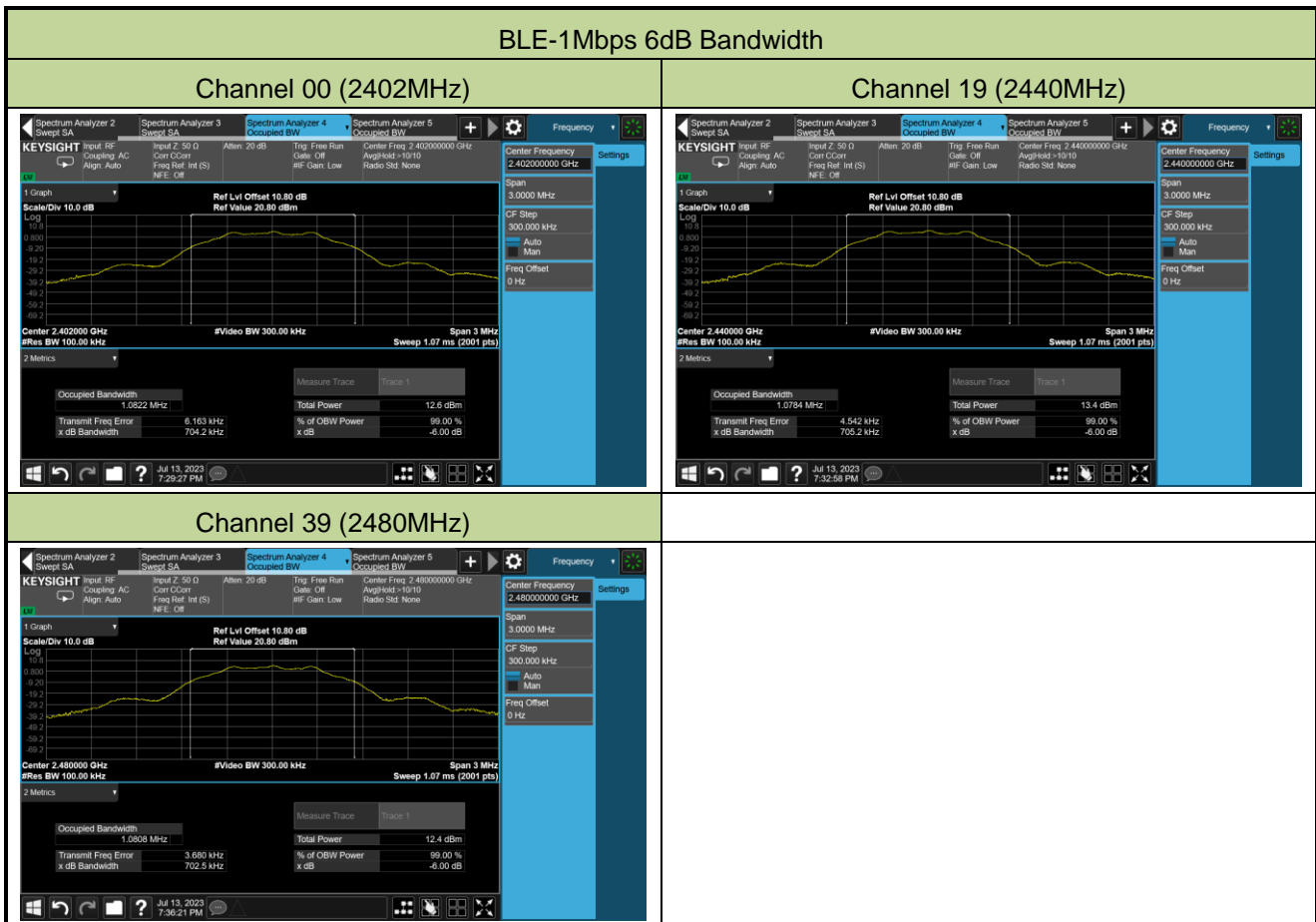

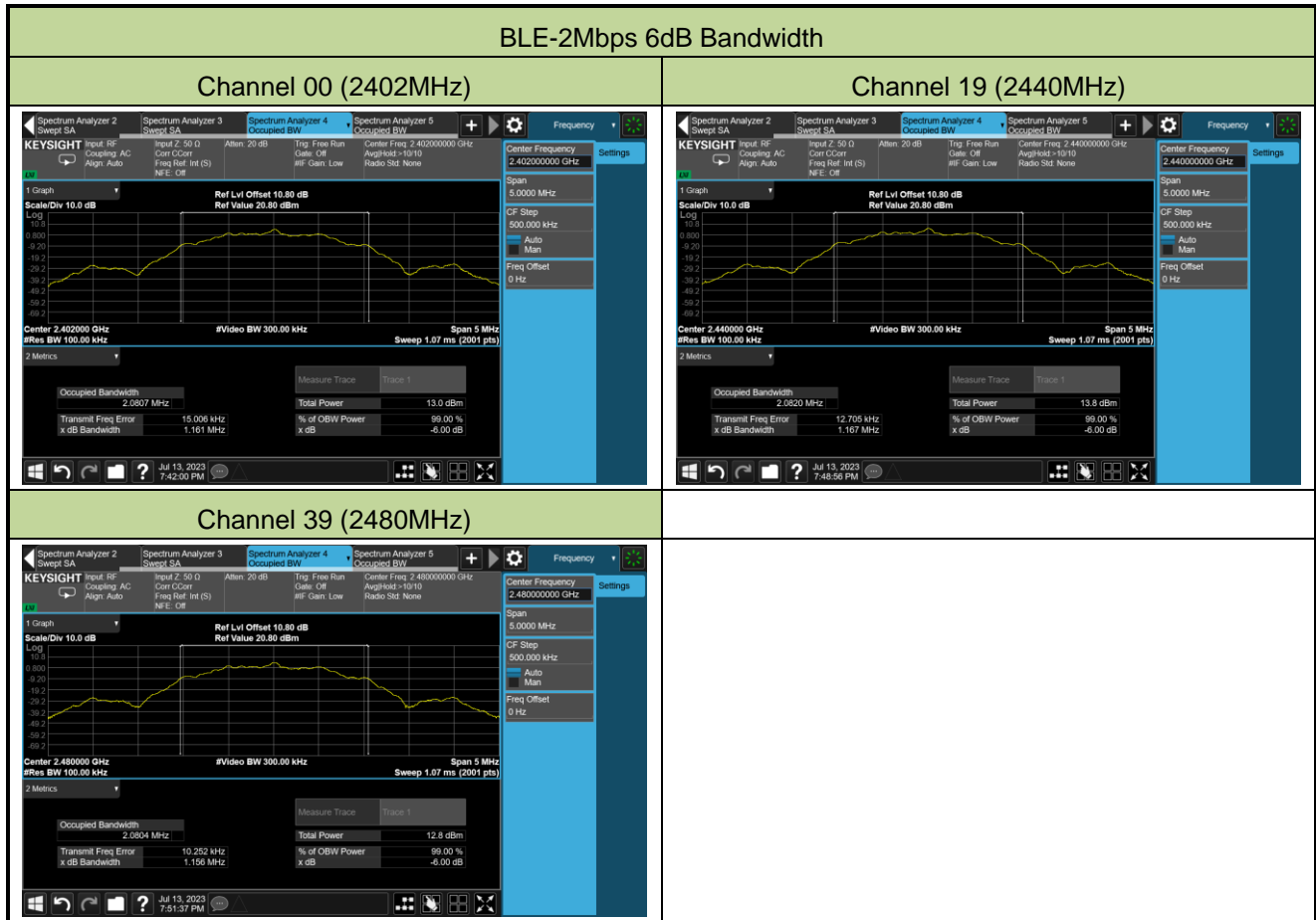

**A.3 Output Power Test Result**

Test Site	WZ-SR5	Test Engineer	Lynn Yang
Test Date	2023-07-28		

**Test Result of Peak Output Power**

Test Mode	Data Rate	Channel No.	Frequency (MHz)	Peak Power (dBm)	Limit (dBm)	Result
BLE	1Mbps	00	2402	6.24	≤ 30.00	Pass
BLE	1Mbps	19	2440	6.72	≤ 30.00	Pass
BLE	1Mbps	39	2480	5.84	≤ 30.00	Pass
BLE	2Mbps	00	2402	6.13	≤ 30.00	Pass
BLE	2Mbps	19	2440	6.79	≤ 30.00	Pass
BLE	2Mbps	39	2480	5.83	≤ 30.00	Pass

**Test Result of Average Output Power (Reporting Only)**

Test Mode	Data Rate	Channel No.	Frequency (MHz)	Average Power (dBm)	Limit (dBm)	Result
BLE	1Mbps	00	2402	5.85	≤ 30.00	Pass
BLE	1Mbps	19	2440	6.59	≤ 30.00	Pass
BLE	1Mbps	39	2480	5.54	≤ 30.00	Pass
BLE	2Mbps	00	2402	5.79	≤ 30.00	Pass
BLE	2Mbps	19	2440	6.66	≤ 30.00	Pass
BLE	2Mbps	39	2480	5.57	≤ 30.00	Pass

**A.4 Power Spectral Density Test Result**

Test Site	WZ-SR5	Test Engineer	Lynn Yang
Test Date	2023-07-13		

Test Mode	Data Rate	Channel No.	Frequency (MHz)	PSD Result (dBm / 3kHz)	Limit (dBm / 3kHz)	Result
BLE	1Mbps	00	2402	-9.68	≤ 8.00	Pass
BLE	1Mbps	19	2440	-8.81	≤ 8.00	Pass
BLE	1Mbps	39	2480	-9.75	≤ 8.00	Pass
BLE	2Mbps	00	2402	-12.29	≤ 8.00	Pass
BLE	2Mbps	19	2440	-11.35	≤ 8.00	Pass
BLE	2Mbps	39	2480	-12.35	≤ 8.00	Pass

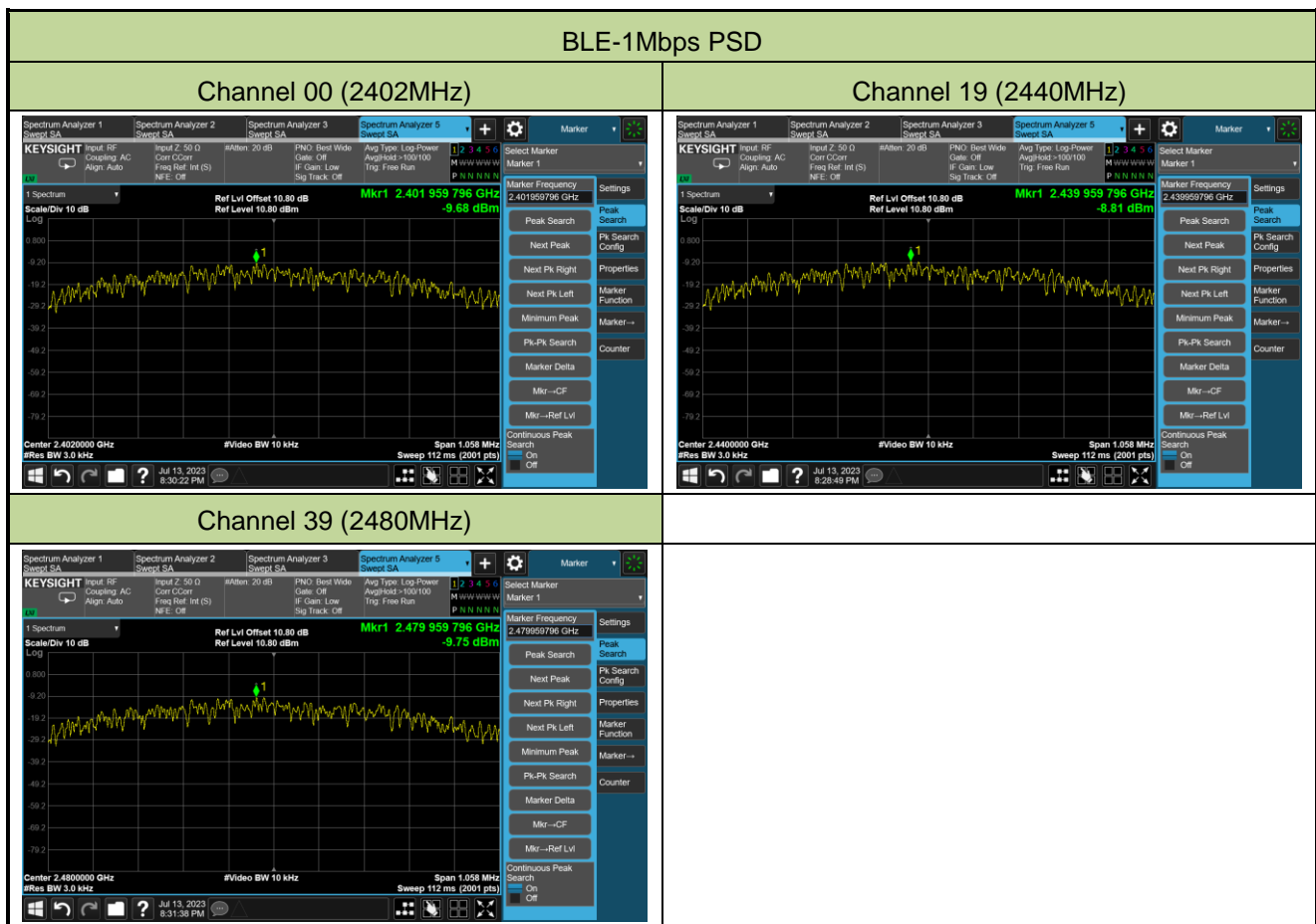

BLE-2Mbps PSD

Channel 00 (2402MHz)

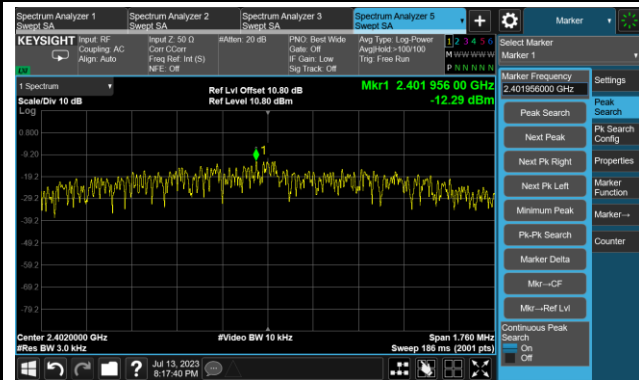

Channel 19 (2440MHz)



Channel 39 (2480MHz)

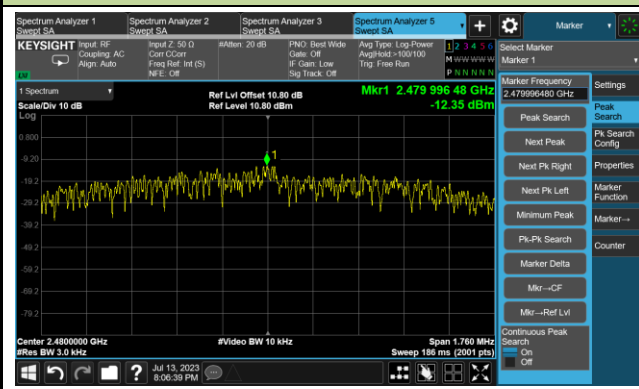



**A.5 Conducted Band Edge and Out-of-Band Emissions Test Result**

Test Site	WZ-SR5	Test Engineer	Lynn Yang
Test Date	2023-07-13		

Test Mode	Data Rate / Mbps	Channel No.	Frequency (MHz)	Limit (dBc)	Result
BLE	1	00	2402	20	Pass
BLE	1	19	2440	20	Pass
BLE	1	39	2480	20	Pass
BLE	2	00	2402	20	Pass
BLE	2	19	2440	20	Pass
BLE	2	39	2480	20	Pass

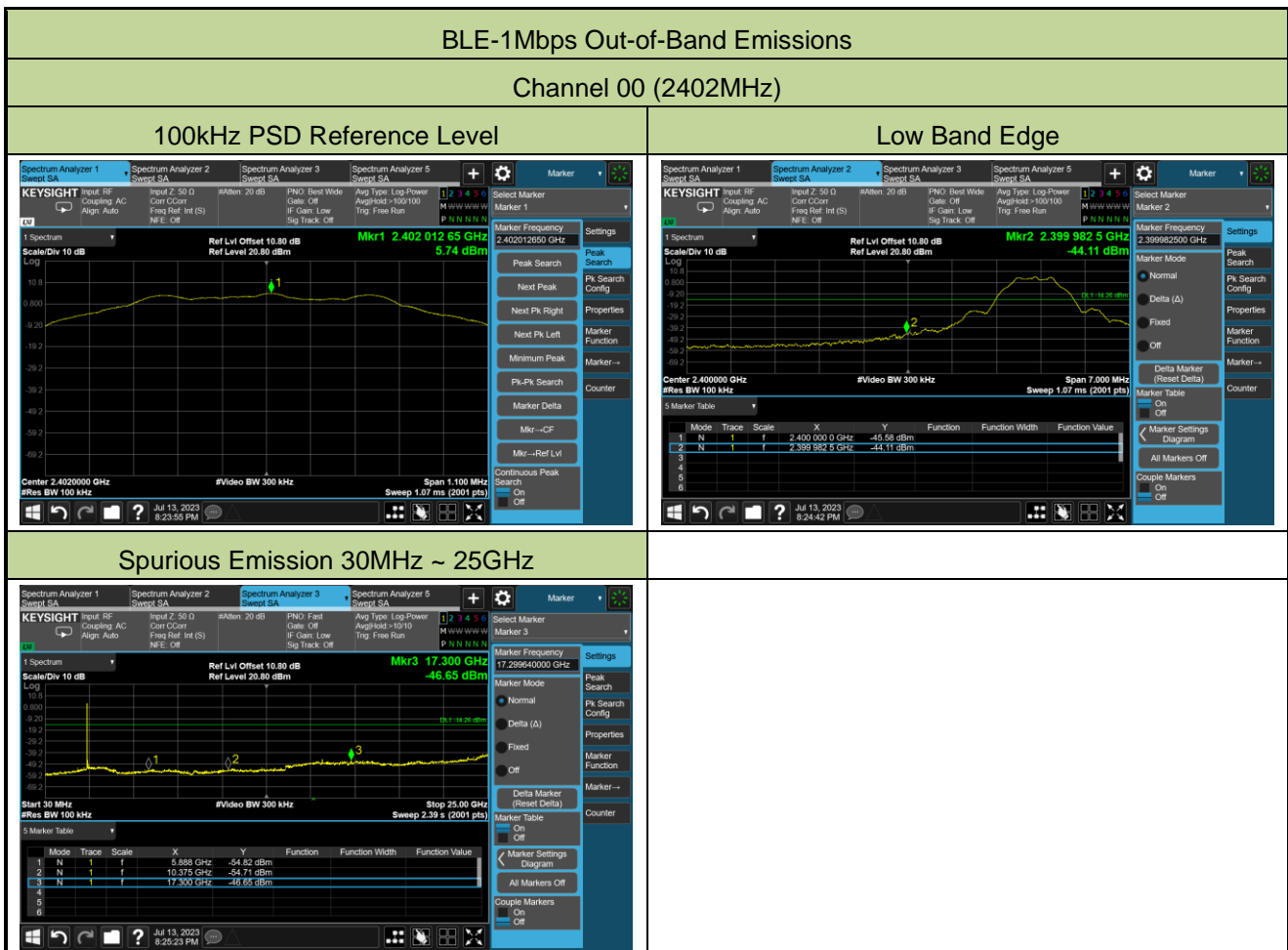

Channel 19 (2440MHz)

100kHz PSD Reference Level

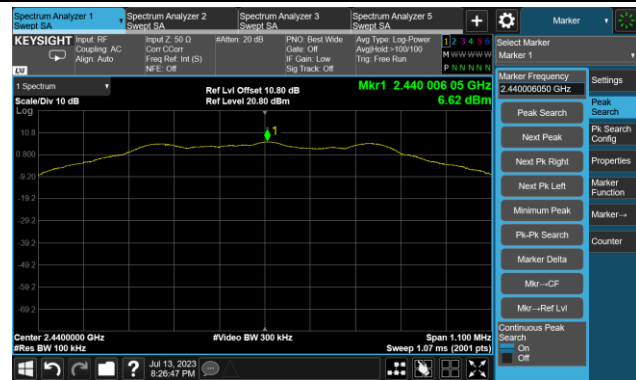

Spurious Emission 30MHz ~ 25GHz

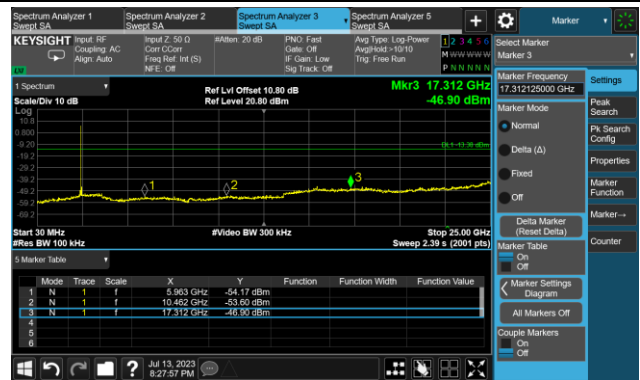

Channel 39 (2480MHz)

100kHz PSD Reference Level

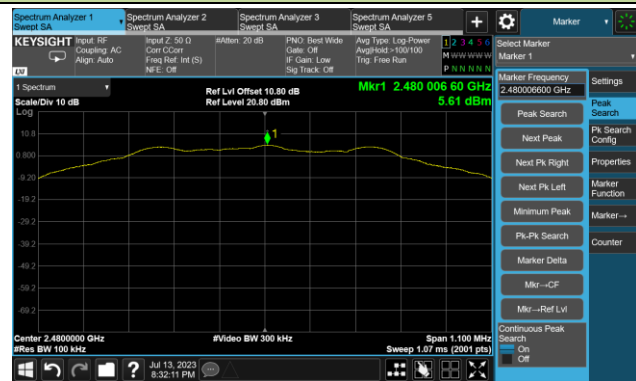

High Band Edge

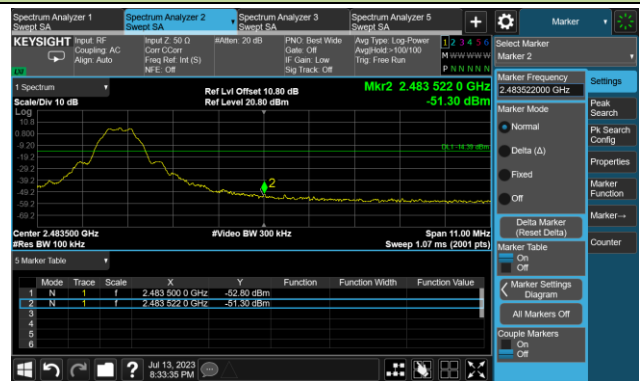

Spurious Emission 30MHz ~ 25GHz

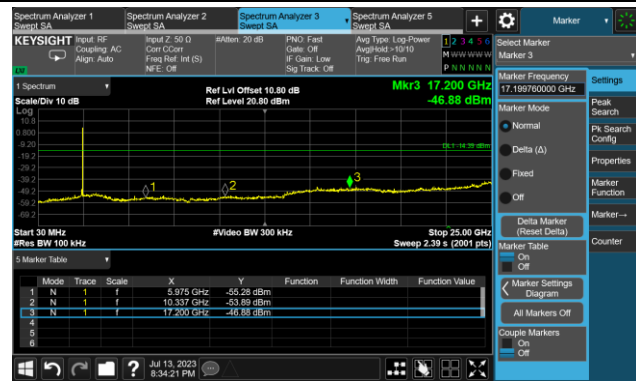

## BLE-2Mbps Out-of-Band Emissions

### Channel 00 (2402MHz)

#### 100kHz PSD Reference Level

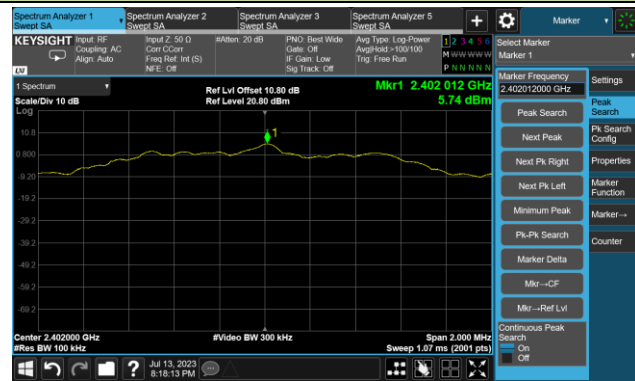

#### Low Band Edge

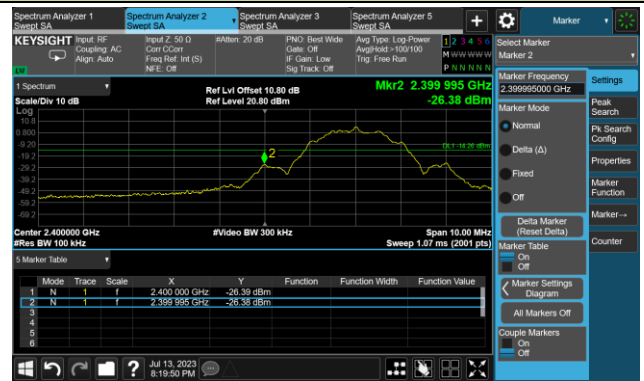

#### Spurious Emission 30MHz ~ 25GHz

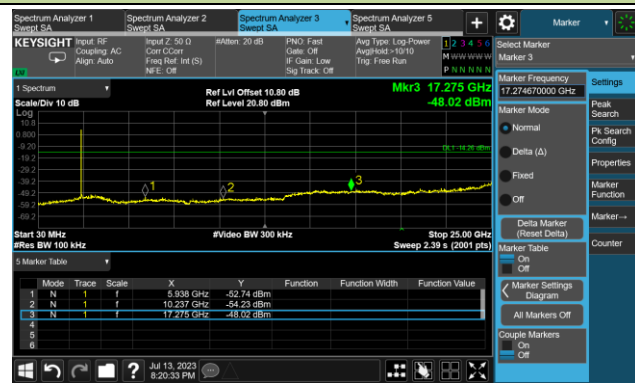

### Channel 19 (2440MHz)

#### 100kHz PSD Reference Level

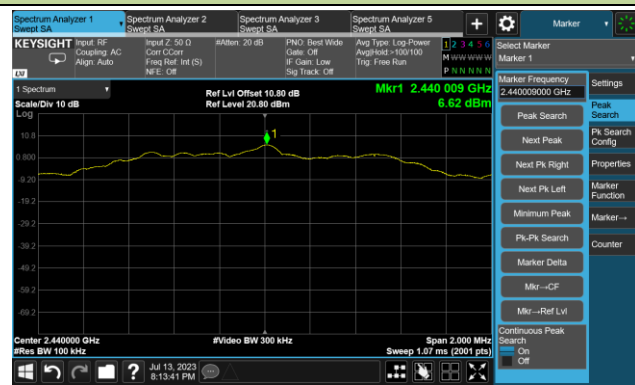

#### Spurious Emission 30MHz ~ 25GHz

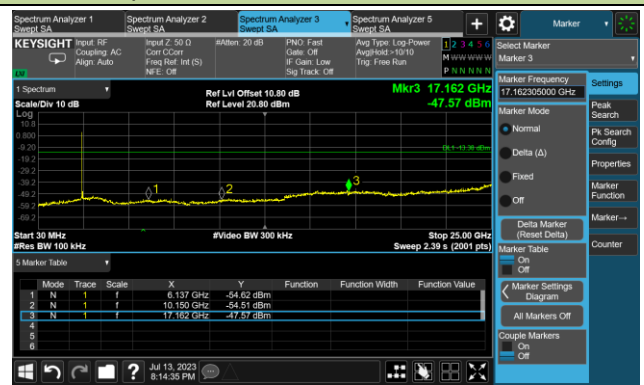



**A.6 Radiated Spurious Emission Test Result**

Test Site	WZ-AC2	Test Engineer	Dick Shen
Test Date	2023-07-25	Test Mode:	BLE-1Mbps
Remark:	1. Average measurement was not performed if peak level lower than average limit. 2. Other frequency was 20dB below limit line within 1-18GHz, there is not show in the report.		

Test Channel	Frequency (MHz)	Reading Level (dB $\mu$ V)	Factor (dB/m)	Measure Level (dB $\mu$ V/m)	Limit (dB $\mu$ V/m)	Margin (dB)	Detector	Polarization
00	4000.5	40.5	-0.1	40.4	74.0	-33.6	Peak	Horizontal
	4833.5	35.7	3.3	39.0	74.0	-35.0	Peak	Horizontal
	7460.0	32.2	12.2	44.4	74.0	-29.6	Peak	Horizontal
	4000.5	40.0	-0.1	39.9	74.0	-34.1	Peak	Vertical
	4850.5	35.1	3.3	38.4	74.0	-35.6	Peak	Vertical
	11497.5	31.2	17.5	48.7	74.0	-25.3	Peak	Vertical
19	4000.5	40.1	-0.1	40.0	74.0	-34.0	Peak	Horizontal
	7434.5	30.9	11.9	42.8	74.0	-31.2	Peak	Horizontal
	11557.0	31.8	17.8	49.6	74.0	-24.4	Peak	Horizontal
	4000.5	39.0	-0.1	38.9	74.0	-35.1	Peak	Vertical
	4680.5	35.4	3.7	39.1	74.0	-34.9	Peak	Vertical
	11540.0	31.3	17.5	48.8	74.0	-25.2	Peak	Vertical
39	4000.5	40.2	-0.1	40.1	74.0	-33.9	Peak	Horizontal
	4748.5	34.6	3.7	38.3	74.0	-35.7	Peak	Horizontal
	11837.5	32.1	17.2	49.3	74.0	-24.7	Peak	Horizontal
	4000.5	39.4	-0.1	39.3	74.0	-34.7	Peak	Vertical
	5054.5	35.6	3.4	39.0	74.0	-35.0	Peak	Vertical
	11157.5	31.9	16.7	48.6	74.0	-25.4	Peak	Vertical

Note: Measure Level (dB $\mu$ V/m) = Reading Level (dB $\mu$ V) + Factor (dB/m)

Factor (dB/m) = Cable Loss (dB) + Antenna Factor (dB/m) - Pre\_Amplifier Gain (dB)

Test Site	WZ-AC2	Test Engineer	Dick Shen
Test Date	2023-07-25	Test Mode:	BLE-2Mbps
Remark:	1. Average measurement was not performed if peak level lower than average limit. 2. Other frequency was 20dB below limit line within 1-18GHz, there is not show in the report.		

Test Channel	Frequency (MHz)	Reading Level (dBμV)	Factor (dB/m)	Measure Level (dBμV/m)	Limit (dBμV/m)	Margin (dB)	Detector	Polarization
00	4000.5	40.1	-0.1	40.0	74.0	-34.0	Peak	Horizontal
	4842.0	35.1	3.3	38.4	74.0	-35.6	Peak	Horizontal
	10809.0	32.1	16.3	48.4	74.0	-25.6	Peak	Horizontal
	4000.5	38.8	-0.1	38.7	74.0	-35.3	Peak	Vertical
	4816.5	34.5	3.3	37.8	74.0	-36.2	Peak	Vertical
	11455.0	31.5	17.3	48.8	74.0	-25.2	Peak	Vertical
19	4000.5	40.4	-0.1	40.3	74.0	-33.7	Peak	Horizontal
	4833.5	35.8	3.3	39.1	74.0	-34.9	Peak	Horizontal
	11642.0	31.3	17.9	49.2	74.0	-24.8	Peak	Horizontal
	4000.5	39.2	-0.1	39.1	74.0	-34.9	Peak	Vertical
	4757.0	34.6	3.8	38.4	74.0	-35.6	Peak	Vertical
	11013.0	31.9	16.4	48.3	74.0	-25.7	Peak	Vertical
39	4000.5	41.0	-0.1	40.9	74.0	-33.1	Peak	Horizontal
	4587.0	34.5	3.1	37.6	74.0	-36.4	Peak	Horizontal
	11472.0	31.4	17.4	48.8	74.0	-25.2	Peak	Horizontal
	4000.5	40.3	-0.1	40.2	74.0	-33.8	Peak	Vertical
	4842.0	35.7	3.3	39.0	74.0	-35.0	Peak	Vertical
	10945.0	32.4	16.2	48.6	74.0	-25.4	Peak	Vertical

Note: Measure Level (dBμV/m) = Reading Level (dBμV) + Factor (dB/m)

Factor (dB/m) = Cable Loss (dB) + Antenna Factor (dB/m) - Pre\_Amplifier Gain (dB)

**The Result of Radiated Emission 9kHz ~ 30MHz:**

Site: WZ-AC1	Test Date: 2023-07-26
Limit: FCC_Part15.209_RSE	Engineer: Carl Jiang
Probe: FMZB1519_0.009-30MHz	Polarity: Coaxial
EUT: HPE Aruba User Experience Sensor	Power: AC 120V/60Hz
Test Mode: Transmit by BLE 1Mbps at 2440MHz	

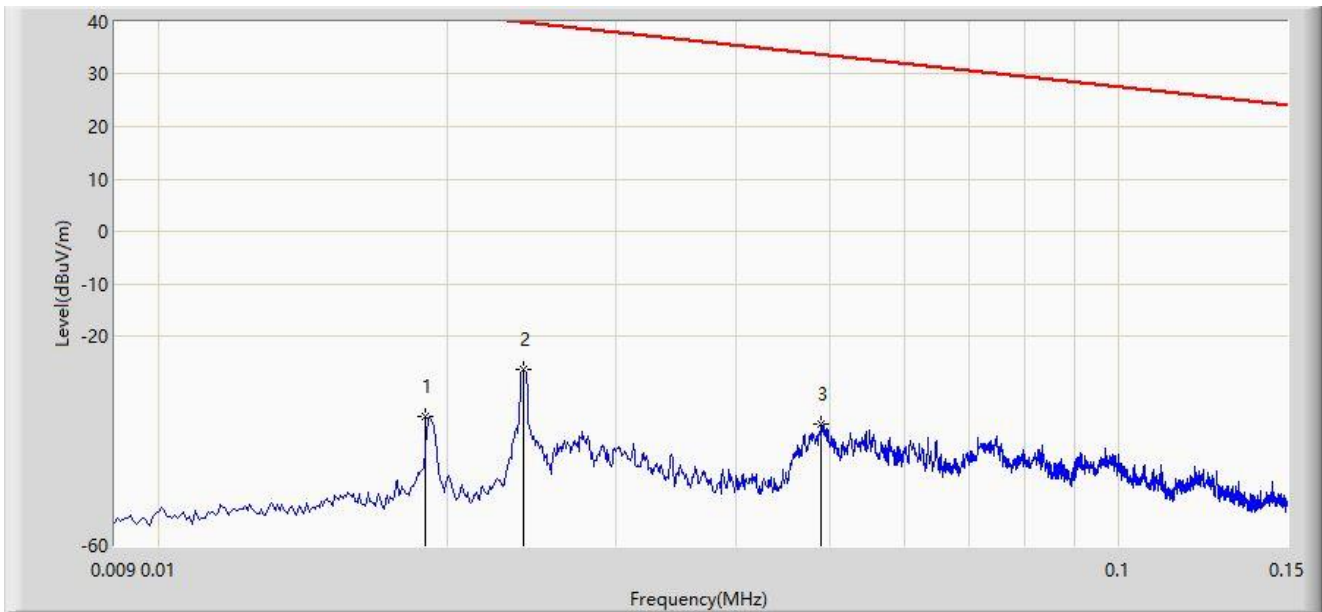

No	Mark	Frequency (MHz)	Measure Level (dB $\mu$ V/m)	Reading Level (dB $\mu$ V)	Margin (dB)	Limit (dB $\mu$ V/m)	Factor (dB/m)	Type
1		0.019	-35.429	24.457	-77.442	42.013	-59.886	PK
2	*	0.024	-26.366	34.110	-66.351	39.985	-60.476	PK
3		0.049	-36.828	25.517	-70.617	33.789	-62.345	PK

Note 1: " \* ", means this data is the worst emission level.

Note 2: Measure Level (dB $\mu$ V/m) = Reading Level (dB $\mu$ V) + Factor (dB/m).

Note 3: Factor (dB/m) = Cable Loss (dB) + Antenna Factor (dB/m) + 40log(d1/d2) (dB), d1 = 3m, d2 = 300m (9kHz-490kHz) or 30m (490kHz-30MHz).

Note 4: Quasi-Peak measurement was not performed when peak measure level was lower than the quasi-peak limit.

Site: WZ-AC1	Test Date: 2023-07-26
Limit: FCC_Part15.209_RSE	Engineer: Carl Jiang
Probe: FMZB1519_0.009-30MHz	Polarity: Coaxial
EUT: HPE Aruba User Experience Sensor	Power: AC 120V/60Hz
Test Mode: Transmit by BLE 1Mbps at 2440MHz	

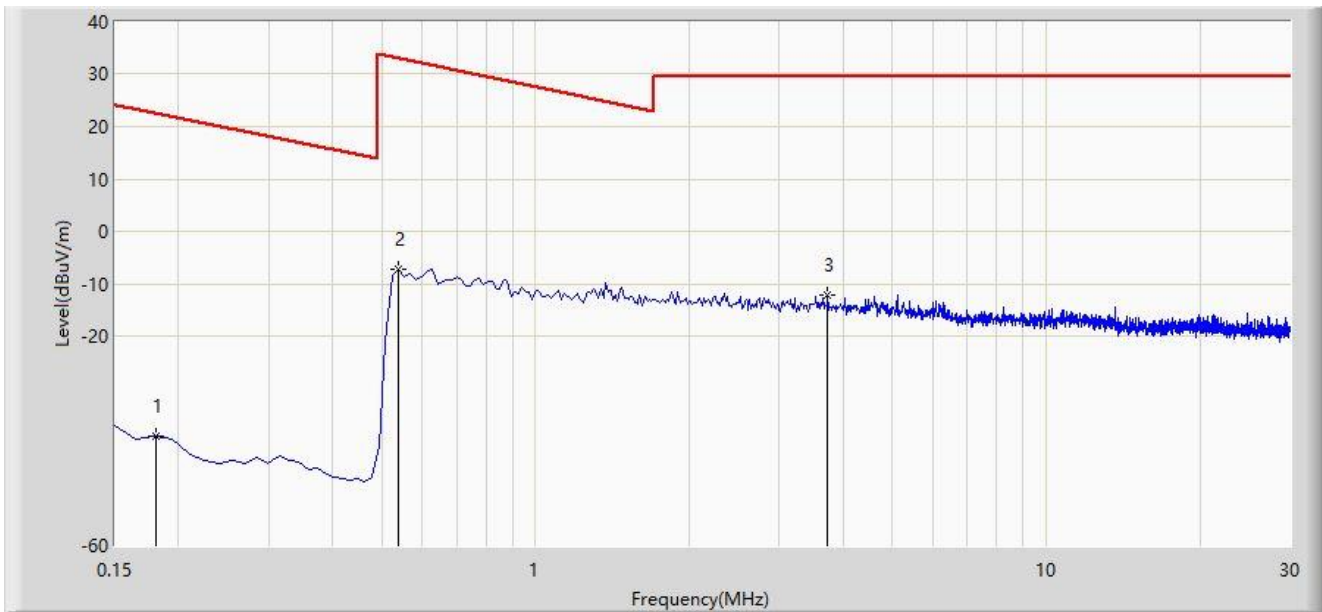

No	Mark	Frequency (MHz)	Measure Level (dB $\mu$ V/m)	Reading Level (dB $\mu$ V)	Margin (dB)	Limit (dB $\mu$ V/m)	Factor (dB/m)	Type
1		0.180	-39.146	23.474	-61.639	22.494	-62.619	PK
2	*	0.538	-7.165	15.224	-40.156	32.991	-22.390	PK
3		3.732	-12.318	9.969	-41.818	29.500	-22.287	PK

Note 1: " \* ", means this data is the worst emission level.

Note 2: Measure Level (dB $\mu$ V/m) = Reading Level (dB $\mu$ V) + Factor (dB/m).

Note 3: Factor (dB/m) = Cable Loss (dB) + Antenna Factor (dB/m) + 40log(d1/d2) (dB), d1 = 3m, d2 = 300m (9kHz-490kHz) or 30m (490kHz-30MHz).

Note 4: Quasi-Peak measurement was not performed when peak measure level was lower than the quasi-peak limit.



Site: WZ-AC1	Test Date: 2023-07-26
Limit: FCC_Part15.209_RSE	Engineer: Carl Jiang
Probe: FMZB1519_0.009-30MHz	Polarity: Coplanar
EUT: HPE Aruba User Experience Sensor	Power: AC 120V/60Hz
Test Mode: Transmit by BLE 1Mbps at 2440MHz	

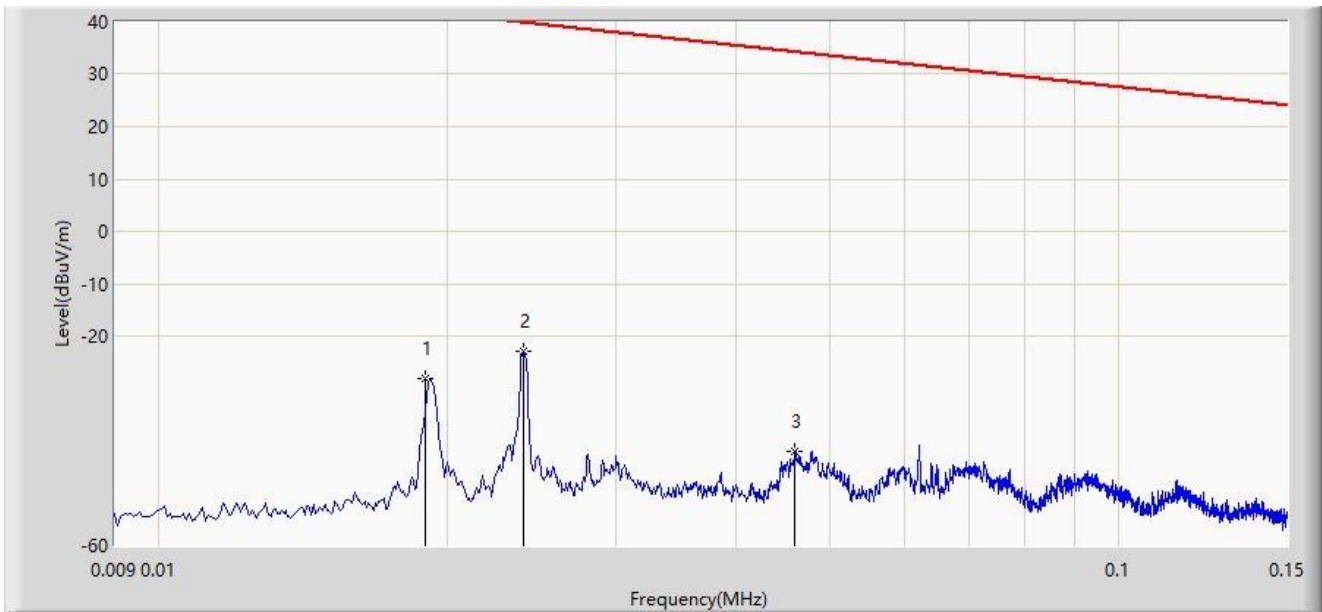

No	Mark	Frequency (MHz)	Measure Level (dBμV/m)	Reading Level (dBμV)	Margin (dB)	Limit (dBμV/m)	Factor (dB/m)	Type
1		0.019	-28.082	31.804	-70.095	42.013	-59.886	PK
2	*	0.024	-23.040	37.436	-63.025	39.985	-60.476	PK
3		0.046	-42.088	20.227	-76.426	34.337	-62.316	PK

Note 1: " \* ", means this data is the worst emission level.

Note 2: Measure Level (dBμV/m) = Reading Level (dBμV) + Factor (dB/m).

Note 3: Factor (dB/m) = Cable Loss (dB) + Antenna Factor (dB/m) + 40log(d1/d2) (dB), d1 = 3m, d2 = 300m (9kHz-490kHz) or 30m (490kHz-30MHz).

Note 4: Quasi-Peak measurement was not performed when peak measure level was lower than the quasi-peak limit.

Site: WZ-AC1	Test Date: 2023-07-26
Limit: FCC_Part15.209_RSE	Engineer: Carl Jiang
Probe: FMZB1519_0.009-30MHz	Polarity: Coplanar
EUT: HPE Aruba User Experience Sensor	Power: AC 120V/60Hz
Test Mode: Transmit by BLE 1Mbps at 2440MHz	

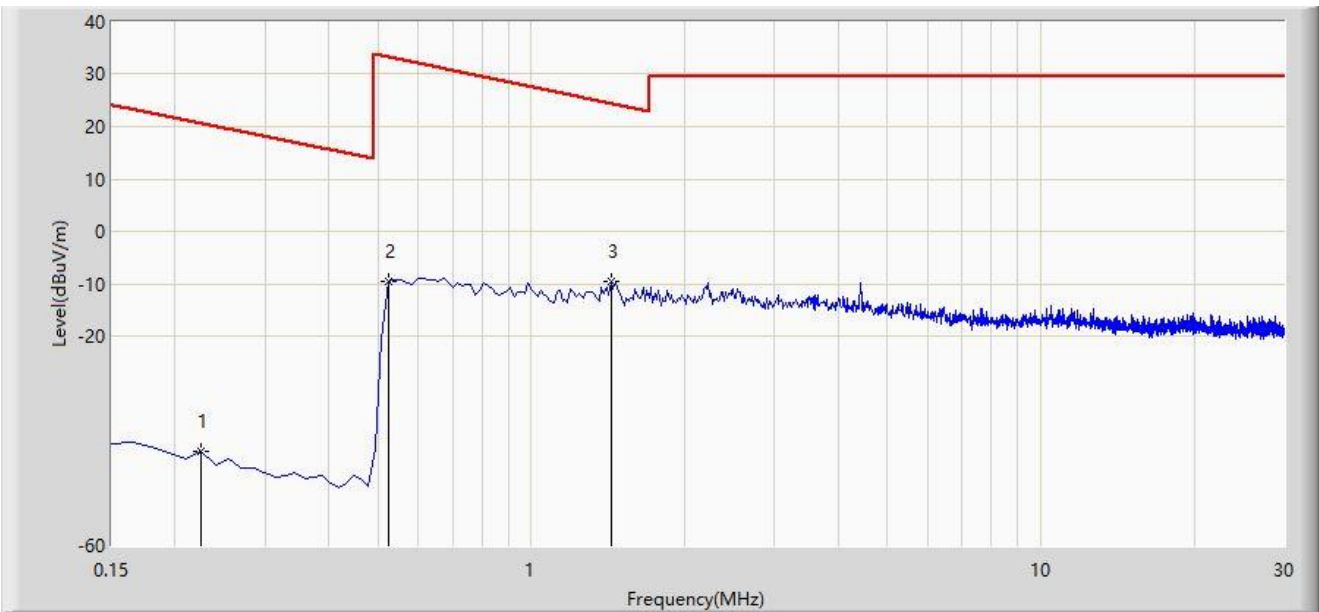

No	Mark	Frequency (MHz)	Measure Level (dB $\mu$ V/m)	Reading Level (dB $\mu$ V)	Margin (dB)	Limit (dB $\mu$ V/m)	Factor (dB/m)	Type
1		0.225	-42.005	20.606	-62.562	20.557	-62.611	PK
2		0.523	-9.461	12.936	-42.696	33.235	-22.397	PK
3	*	1.434	-9.696	12.643	-34.195	24.499	-22.339	PK

Note 1: " \* ", means this data is the worst emission level.

Note 2: Measure Level (dB $\mu$ V/m) = Reading Level (dB $\mu$ V) + Factor (dB/m).

Note 3: Factor (dB/m) = Cable Loss (dB) + Antenna Factor (dB/m) + 40log(d1/d2) (dB), d1 = 3m, d2 = 300m (9kHz-490kHz) or 30m (490kHz-30MHz).

Note 4: Quasi-Peak measurement was not performed when peak measure level was lower than the quasi-peak limit.

**The Result of Radiated Emission 30M ~ 1GHz:**

Site: WZ-AC1	Test Date: 2023-08-11
Limit: FCC_Part15.209_RSE(3m)	Engineer: Ajin Fan
Probe: VULB 9168_25-2000MHz	Polarity: Horizontal
EUT: HPE Aruba User Experience Sensor	Power: AC 120V/60Hz
Test Mode: Transmit by BLE 1Mbps at 2440MHz	

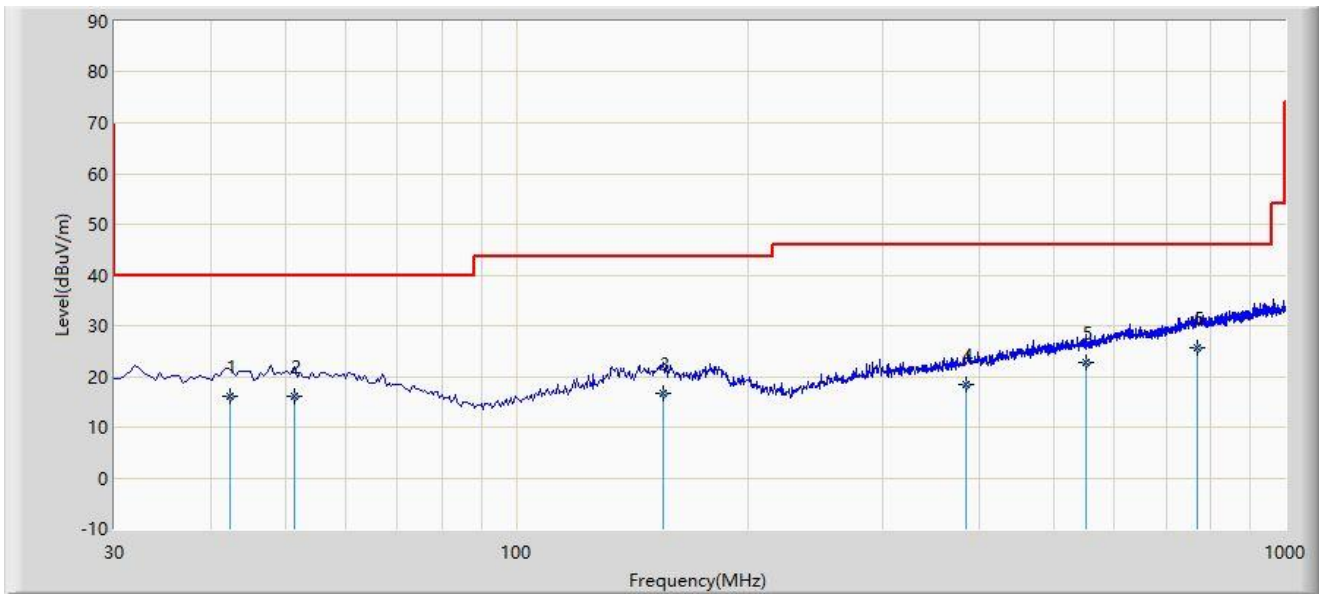

No	Mark	Frequency (MHz)	Measure Level (dB $\mu$ V/m)	Reading Level (dB $\mu$ V)	Margin (dB)	Limit (dB $\mu$ V/m)	Factor (dB/m)	Type
1		42.360	16.114	-2.150	-23.886	40.000	18.264	QP
2		51.360	16.192	-2.390	-23.808	40.000	18.582	QP
3		155.390	16.585	-1.690	-26.915	43.500	18.275	QP
4		385.230	18.291	-2.330	-27.709	46.000	20.621	QP
5		550.130	22.716	-1.390	-23.284	46.000	24.106	QP
6	*	768.030	25.686	-2.440	-20.314	46.000	28.127	QP

Note 1: " \* ", means this data is the worst emission level.

Note 2: Measure Level (dB $\mu$ V/m) = Reading Level (dB $\mu$ V) + Factor (dB/m).

Note 3: Factor (dB/m) = Cable Loss (dB) + Antenna Factor (dB/m).

Site: WZ-AC1	Test Date: 2023-08-11
Limit: FCC_Part15.209_RSE(3m)	Engineer: Ajin Fan
Probe: VULB 9168_25-2000MHz	Polarity: Vertical
EUT: HPE Aruba User Experience Sensor	Power: AC 120V/60Hz
Test Mode: Transmit by BLE 1Mbps at 2440MHz	

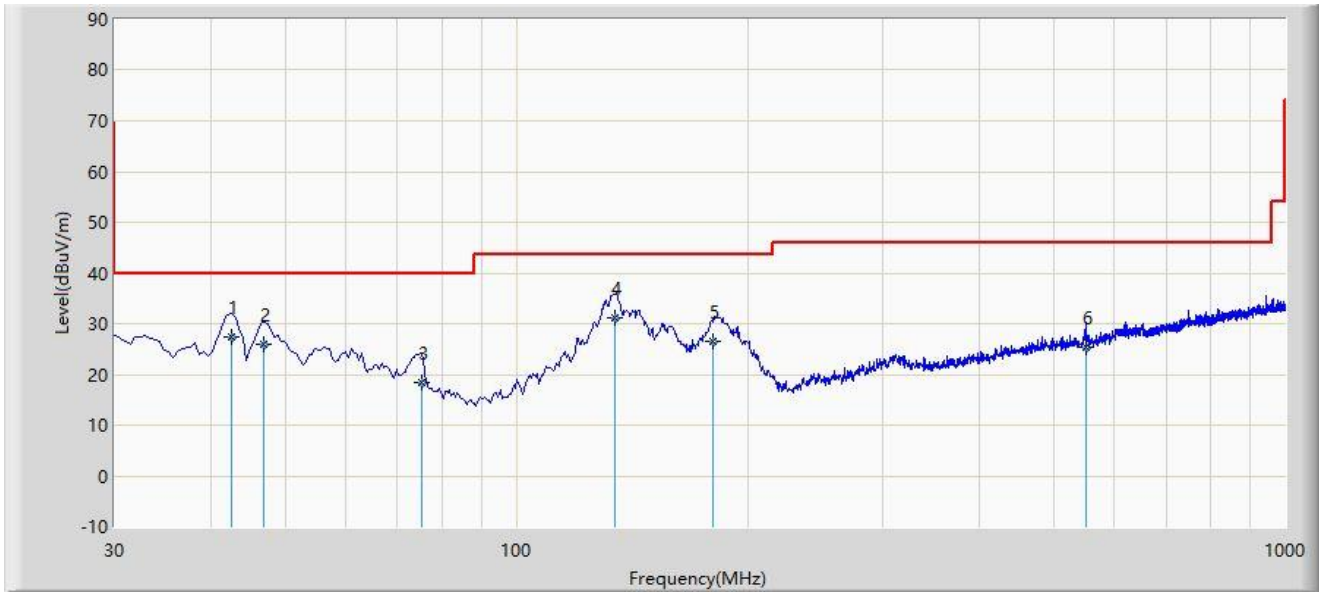

No	Mark	Frequency (MHz)	Measure Level (dB $\mu$ V/m)	Reading Level (dB $\mu$ V)	Margin (dB)	Limit (dB $\mu$ V/m)	Factor (dB/m)	Type
1		42.690	27.412	9.120	-12.588	40.000	18.291	QP
2		46.930	25.883	7.360	-14.117	40.000	18.523	QP
3		75.210	18.536	3.120	-21.464	40.000	15.416	QP
4	*	134.560	31.144	13.890	-12.356	43.500	17.254	QP
5		180.360	26.477	9.630	-17.023	43.500	16.847	QP
6		550.120	25.226	1.120	-20.774	46.000	24.106	QP

Note 1: " \* ", means this data is the worst emission level.

Note 2: Measure Level (dB $\mu$ V/m) = Reading Level (dB $\mu$ V) + Factor (dB/m).

Note 3: Factor (dB/m) = Cable Loss (dB) + Antenna Factor (dB/m).

**The Result of Radiated Emission 1G ~ 18GHz:**

Site: WZ-AC2	Test Date: 2023-07-25
Limit: FCC_Part15.209_RSE(3m)	Engineer: Dick Shen
Probe: BBHA9120D_1457_1-18GHz	Polarity: Horizontal
EUT: HPE Aruba User Experience Sensor	Power: AC 120V/60Hz
Test Mode: Transmit by BLE 1Mbps at 2440MHz	

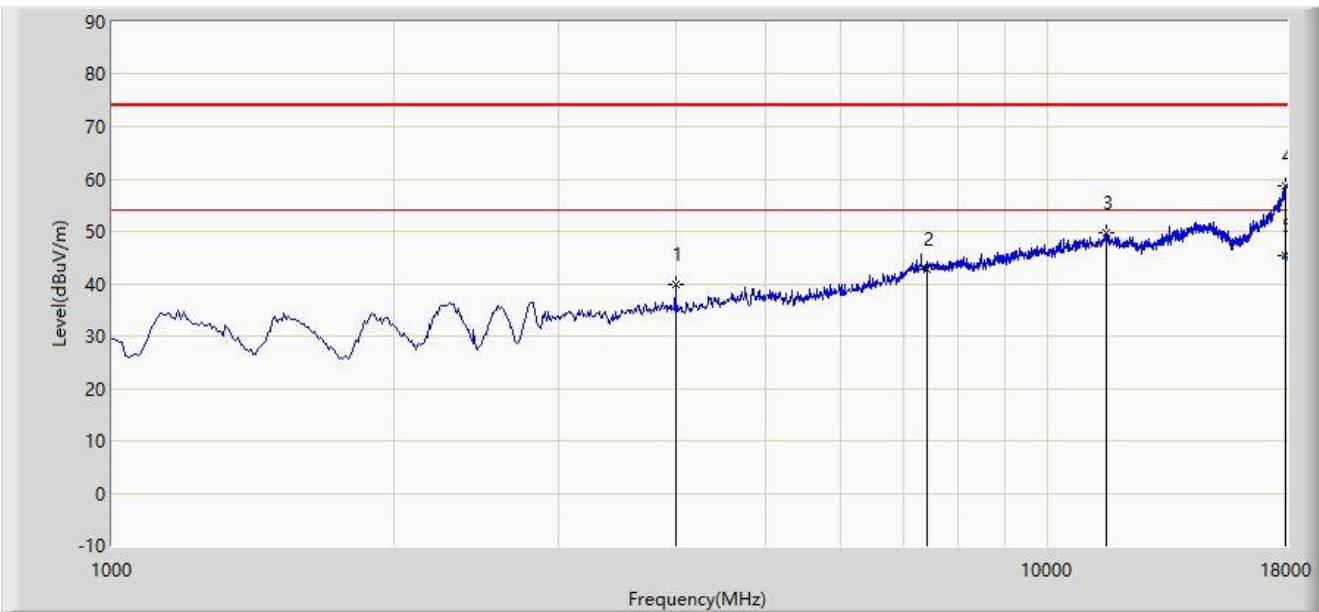

No	Mark	Frequency (MHz)	Measure Level (dB $\mu$ V/m)	Reading Level (dB $\mu$ V)	Margin (dB)	Limit (dB $\mu$ V/m)	Factor (dB/m)	Type
1		4000.500	39.919	40.069	-34.081	74.000	-0.149	PK
2		7434.500	42.801	30.896	-31.199	74.000	11.905	PK
3		11557.000	49.615	31.803	-24.385	74.000	17.812	PK
4		17940.500	58.825	31.770	-15.175	74.000	27.055	PK
5	*	17940.500	45.355	18.300	-8.645	54.000	27.055	AV

Note 1: " \* ", means this data is the worst emission level.

Note 2: Measure Level (dB $\mu$ V/m) = Reading Level (dB $\mu$ V) + Factor (dB/m).

Note 3: Factor (dB/m) = Cable Loss (dB) + Antenna Factor (dB/m) - Pre\_Amplifier Gain (dB).

Note 4: Average measurement was not performed when peak measure level was lower than the average limit.

Site: WZ-AC2	Test Date: 2023-07-25
Limit: FCC_Part15.209_RSE(3m)	Engineer: Dick Shen
Probe: BBHA9120D_1457_1-18GHz	Polarity: Vertical
EUT: HPE Aruba User Experience Sensor	Power: AC 120V/60Hz
Test Mode: Transmit by BLE 1Mbps at 2440MHz	

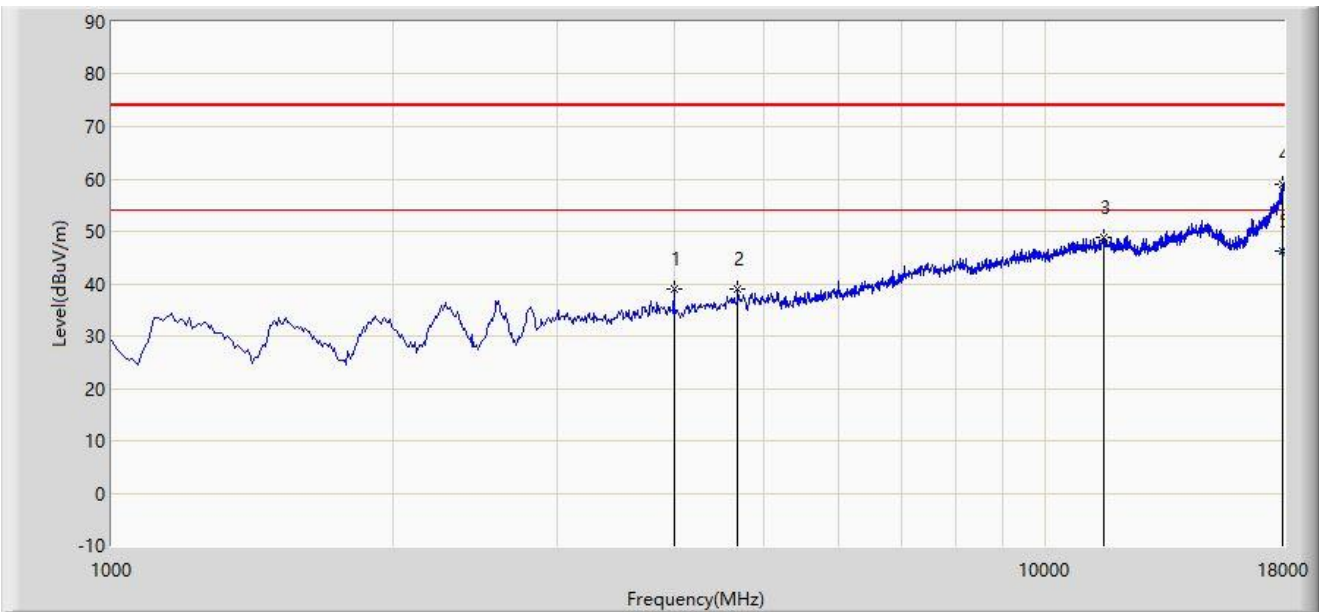

No	Mark	Frequency (MHz)	Measure Level (dB $\mu$ V/m)	Reading Level (dB $\mu$ V)	Margin (dB)	Limit (dB $\mu$ V/m)	Factor (dB/m)	Type
1		4000.500	38.845	38.995	-35.155	74.000	-0.149	PK
2		4680.500	39.097	35.370	-34.903	74.000	3.727	PK
3		11540.000	48.759	31.273	-25.241	74.000	17.486	PK
4		17966.000	58.909	31.056	-15.091	74.000	27.852	PK
5	*	17966.000	46.173	18.320	-7.827	54.000	27.852	AV

Note 1: " \* ", means this data is the worst emission level.

Note 2: Measure Level (dB $\mu$ V/m) = Reading Level (dB $\mu$ V) + Factor (dB/m).

Note 3: Factor (dB/m) = Cable Loss (dB) + Antenna Factor (dB/m) - Pre\_Amplifier Gain (dB).

Note 4: Average measurement was not performed when peak measure level was lower than the average limit.

**The Result of Radiated Emission 18G ~ 25GHz:**

Site: WZ-AC2	Test Date: 2023-08-13
Limit: FCC_Part15.209_RSE(3m)	Engineer: Dick Shen
Probe: BBHA9170_993_18-40GHz	Polarity: Horizontal
EUT: HPE Aruba User Experience Sensor	Power: AC 120V/60Hz
Test Mode: Transmit by BLE 1Mbps at 2440MHz	

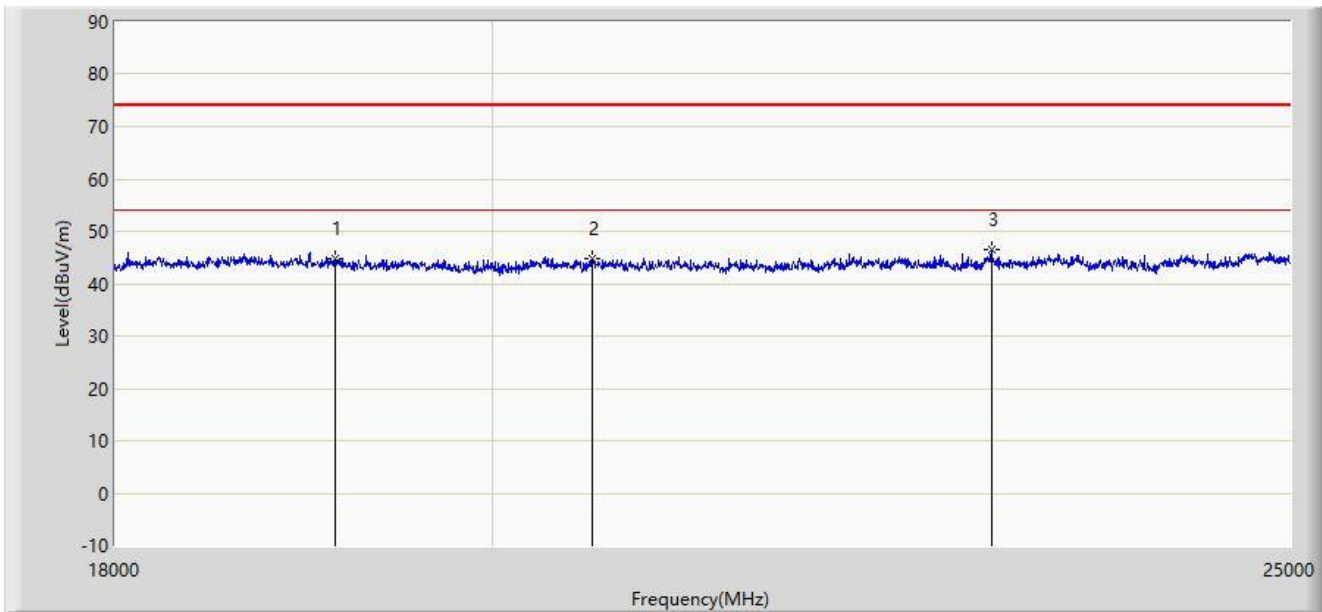

No	Mark	Frequency (MHz)	Measure Level (dB $\mu$ V/m)	Reading Level (dB $\mu$ V)	Margin (dB)	Limit (dB $\mu$ V/m)	Factor (dB/m)	Type
1		19141.000	44.821	55.171	-29.179	74.000	-10.350	PK
2		20572.500	44.923	54.355	-29.077	74.000	-9.433	PK
3	*	22998.000	46.639	53.706	-27.361	74.000	-7.067	PK

Note 1: " \* ", means this data is the worst emission level.

Note 2: Measure Level (dB $\mu$ V/m) = Reading Level (dB $\mu$ V) + Factor (dB/m).

Note 3: Factor (dB/m) = Cable Loss (dB) + Antenna Factor (dB/m) - Pre\_Amplifier Gain (dB).

Note 4: Average measurement was not performed when peak measure level was lower than the average limit.

Site: WZ-AC2	Test Date: 2023-08-13
Limit: FCC_Part15.209_RSE(3m)	Engineer: Dick Shen
Probe: BBHA9170_993_18-40GHz	Polarity: Vertical
EUT: HPE Aruba User Experience Sensor	Power: AC 120V/60Hz
Test Mode: Transmit by BLE 1Mbps at 2440MHz	

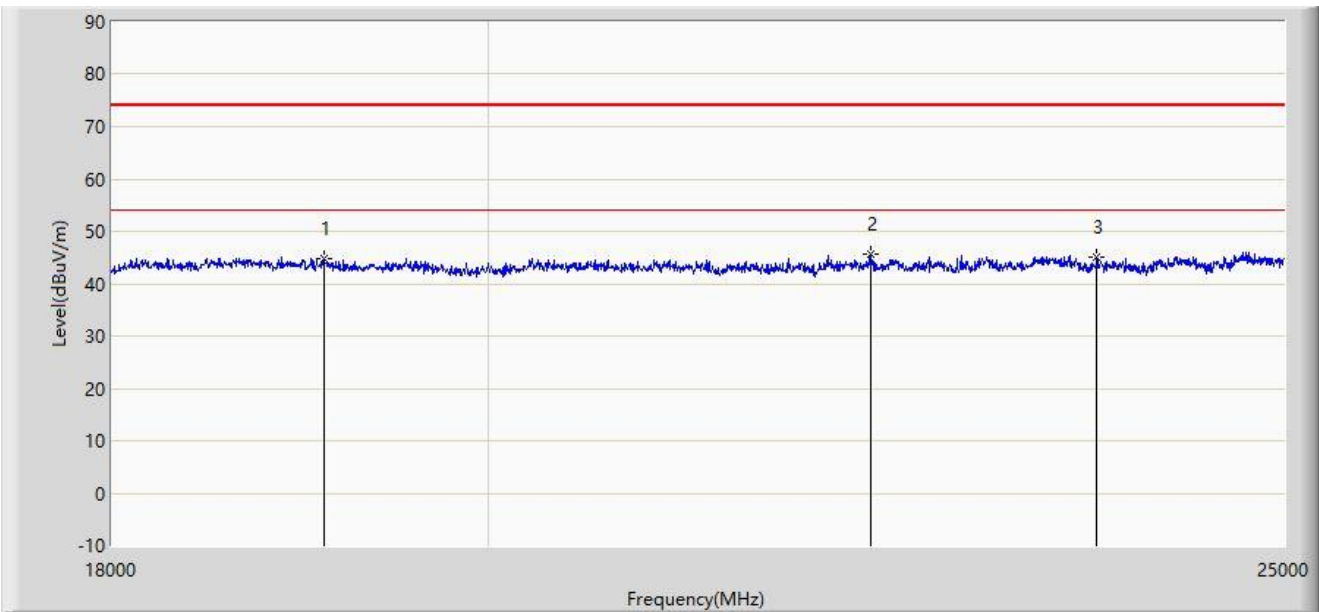

No	Mark	Frequency (MHz)	Measure Level (dB $\mu$ V/m)	Reading Level (dB $\mu$ V)	Margin (dB)	Limit (dB $\mu$ V/m)	Factor (dB/m)	Type
1		19102.500	44.675	55.100	-29.325	74.000	-10.426	PK
2	*	22263.000	45.734	53.313	-28.266	74.000	-7.579	PK
3		23722.500	44.991	52.448	-29.009	74.000	-7.457	PK

Note 1: " \* ", means this data is the worst emission level.

Note 2: Measure Level (dB $\mu$ V/m) = Reading Level (dB $\mu$ V) + Factor (dB/m).

Note 3: Factor (dB/m) = Cable Loss (dB) + Antenna Factor (dB/m) - Pre\_Amplifier Gain (dB).

Note 4: Average measurement was not performed when peak measure level was lower than the average limit.



### A.7 Radiated Restricted Band Edge Test Result

Site: WZ-AC2	Test Date: 2023-07-25
Limit: FCC_2.4G_RE(3m)	Engineer: Dick Shen
Probe: BBHA9120D_1457_1-18GHz	Polarity: Horizontal
EUT: HPE Aruba User Experience Sensor	Power: AC 120V/60Hz
Test Mode: Transmit by BLE 1Mbps at 2402MHz	

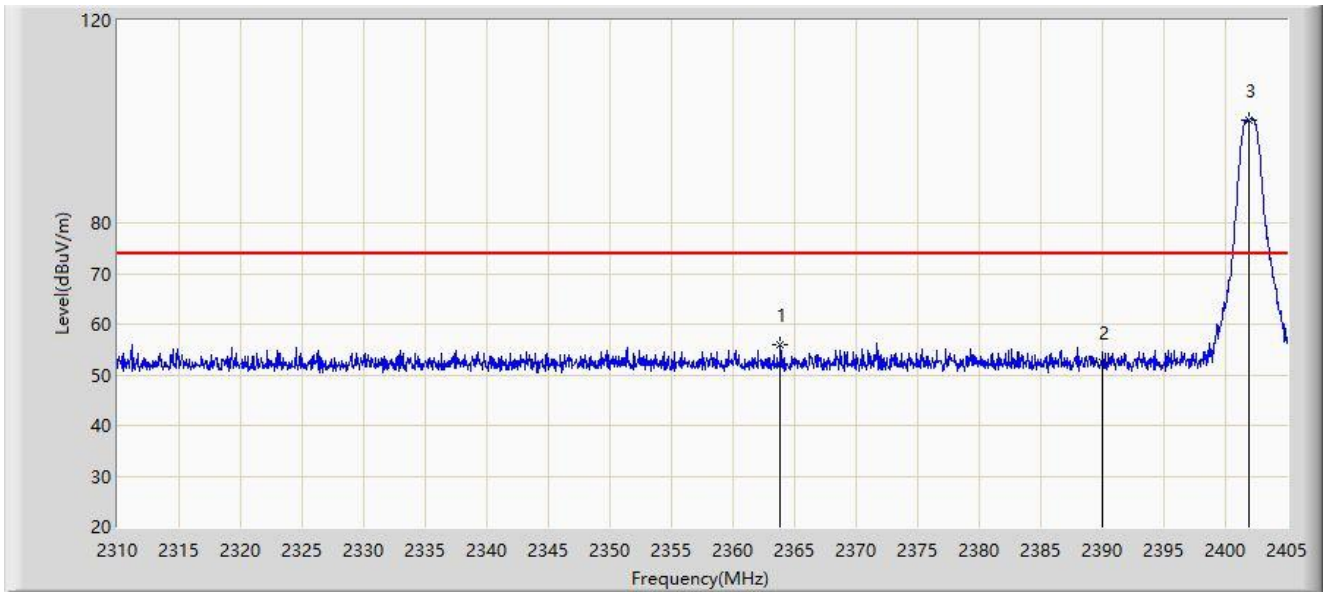

No	Mark	Frequency (MHz)	Measure Level (dB $\mu$ V/m)	Reading Level (dB $\mu$ V)	Margin (dB)	Limit (dB $\mu$ V/m)	Factor (dB/m)	Type
1	*	2363.817	55.966	24.279	-18.034	74.000	31.687	PK
2		2390.000	52.541	20.926	-21.459	74.000	31.615	PK
3		2401.960	100.281	68.731	N/A	N/A	31.550	PK

Note 1: " \* ", means this data is the worst emission level.

Note 2: Measure Level (dB $\mu$ V/m) = Reading Level (dB $\mu$ V) + Factor (dB/m).

Note 3: Factor (dB/m) = Cable Loss (dB) + Antenna Factor (dB/m).

Site: WZ-AC2	Test Date: 2023-07-25
Limit: FCC_2.4G_RE(3m)	Engineer: Dick Shen
Probe: BBHA9120D_1457_1-18GHz	Polarity: Horizontal
EUT: HPE Aruba User Experience Sensor	Power: AC 120V/60Hz
Test Mode: Transmit by BLE 1Mbps at 2402MHz	

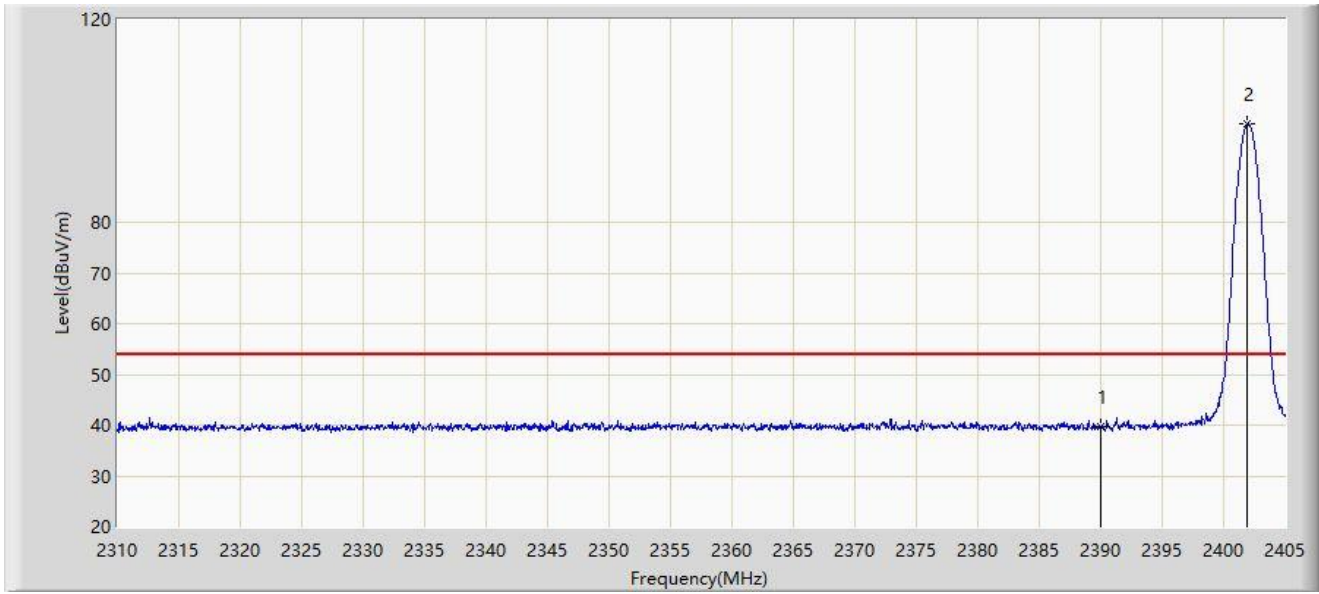

No	Mark	Frequency (MHz)	Measure Level (dB $\mu$ V/m)	Reading Level (dB $\mu$ V)	Margin (dB)	Limit (dB $\mu$ V/m)	Factor (dB/m)	Type
1	*	2390.000	39.727	8.112	-14.273	54.000	31.615	AV
2		2401.960	99.362	67.812	N/A	N/A	31.550	AV

Note 1: " \* ", means this data is the worst emission level.

Note 2: Measure Level (dB $\mu$ V/m) = Reading Level (dB $\mu$ V) + Factor (dB/m).

Note 3: Factor (dB/m) = Cable Loss (dB) + Antenna Factor (dB/m).

Site: WZ-AC2	Test Date: 2023-07-25
Limit: FCC_2.4G_RE(3m)	Engineer: Dick Shen
Probe: BBHA9120D_1457_1-18GHz	Polarity: Vertical
EUT: HPE Aruba User Experience Sensor	Power: AC 120V/60Hz
Test Mode: Transmit by BLE 1Mbps at 2402MHz	

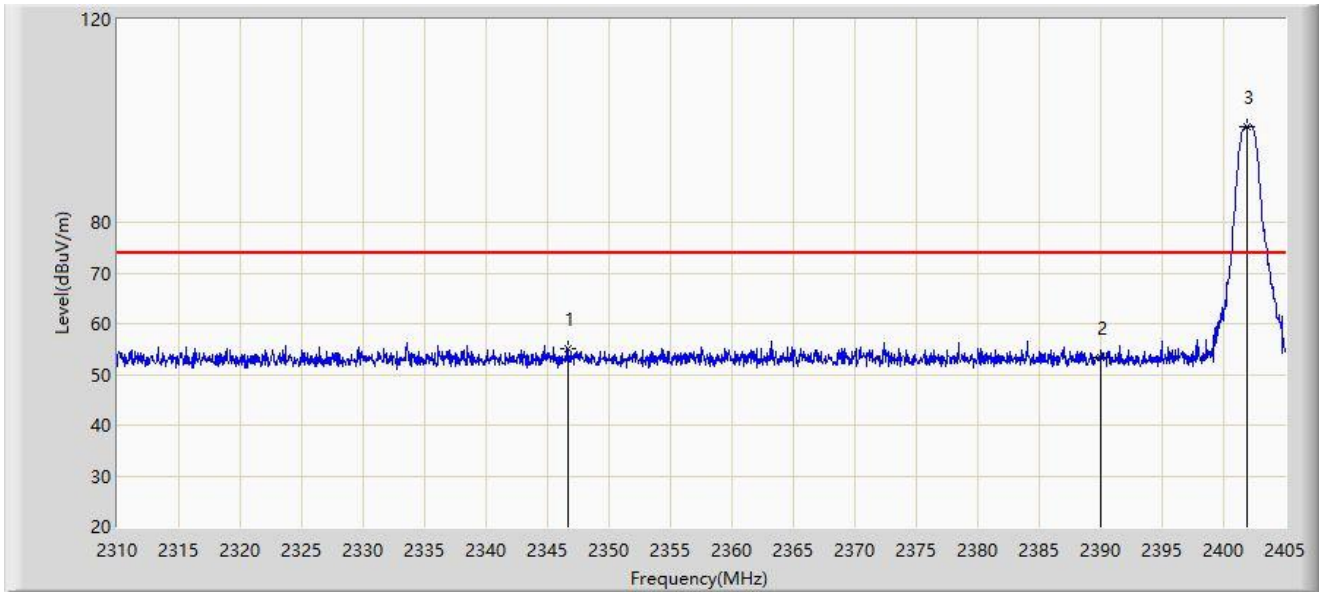

No	Mark	Frequency (MHz)	Measure Level (dB $\mu$ V/m)	Reading Level (dB $\mu$ V)	Margin (dB)	Limit (dB $\mu$ V/m)	Factor (dB/m)	Type
1	*	2346.718	55.000	23.291	-19.000	74.000	31.709	PK
2		2390.000	53.289	21.674	-20.711	74.000	31.615	PK
3		2401.865	98.845	67.295	N/A	N/A	31.550	PK

Note 1: " \* ", means this data is the worst emission level.

Note 2: Measure Level (dB $\mu$ V/m) = Reading Level (dB $\mu$ V) + Factor (dB/m).

Note 3: Factor (dB/m) = Cable Loss (dB) + Antenna Factor (dB/m).

Site: WZ-AC2	Test Date: 2023-07-25
Limit: FCC_2.4G_RE(3m)	Engineer: Dick Shen
Probe: BBHA9120D_1457_1-18GHz	Polarity: Vertical
EUT: HPE Aruba User Experience Sensor	Power: AC 120V/60Hz
Test Mode: Transmit by BLE 1Mbps at 2402MHz	

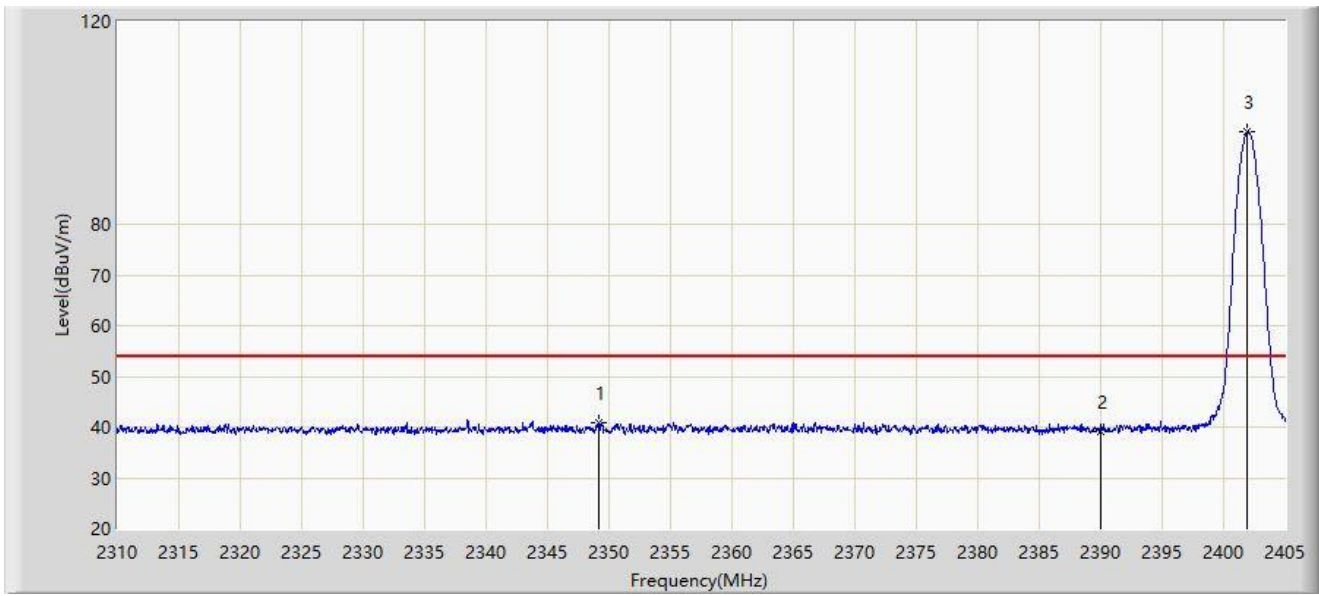

No	Mark	Frequency (MHz)	Measure Level (dB $\mu$ V/m)	Reading Level (dB $\mu$ V)	Margin (dB)	Limit (dB $\mu$ V/m)	Factor (dB/m)	Type
1	*	2349.187	41.012	9.308	-12.988	54.000	31.704	AV
2		2390.000	39.234	7.619	-14.766	54.000	31.615	AV
3		2401.960	98.152	66.602	N/A	N/A	31.550	AV

Note 1: " \* ", means this data is the worst emission level.

Note 2: Measure Level (dB $\mu$ V/m) = Reading Level (dB $\mu$ V) + Factor (dB/m).

Note 3: Factor (dB/m) = Cable Loss (dB) + Antenna Factor (dB/m).

Site: WZ-AC2	Test Date: 2023-07-25
Limit: FCC_2.4G_RE(3m)	Engineer: Dick Shen
Probe: BBHA9120D_1457_1-18GHz	Polarity: Horizontal
EUT: HPE Aruba User Experience Sensor	Power: AC 120V/60Hz
Test Mode: Transmit by BLE 1Mbps at 2480MHz	

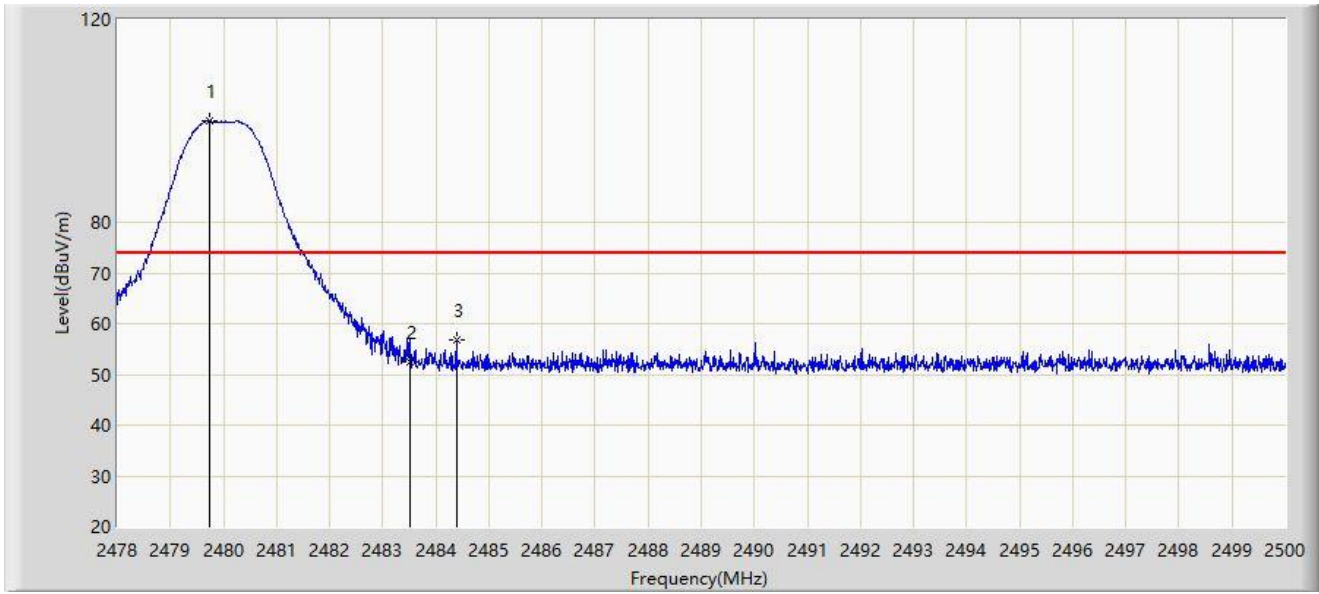

No	Mark	Frequency (MHz)	Measure Level (dBμV/m)	Reading Level (dBμV)	Margin (dB)	Limit (dBμV/m)	Factor (dB/m)	Type
1		2479.727	99.971	68.472	N/A	N/A	31.499	PK
2		2483.500	52.359	20.859	-21.641	74.000	31.500	PK
3	*	2484.391	56.682	25.181	-17.318	74.000	31.501	PK

Note 1: " \* ", means this data is the worst emission level.

Note 2: Measure Level (dBμV/m) = Reading Level (dBμV) + Factor (dB/m).

Note 3: Factor (dB/m) = Cable Loss (dB) + Antenna Factor (dB/m).

Site: WZ-AC2	Test Date: 2023-07-25
Limit: FCC_2.4G_RE(3m)	Engineer: Dick Shen
Probe: BBHA9120D_1457_1-18GHz	Polarity: Horizontal
EUT: HPE Aruba User Experience Sensor	Power: AC 120V/60Hz
Test Mode: Transmit by BLE 1Mbps at 2480MHz	

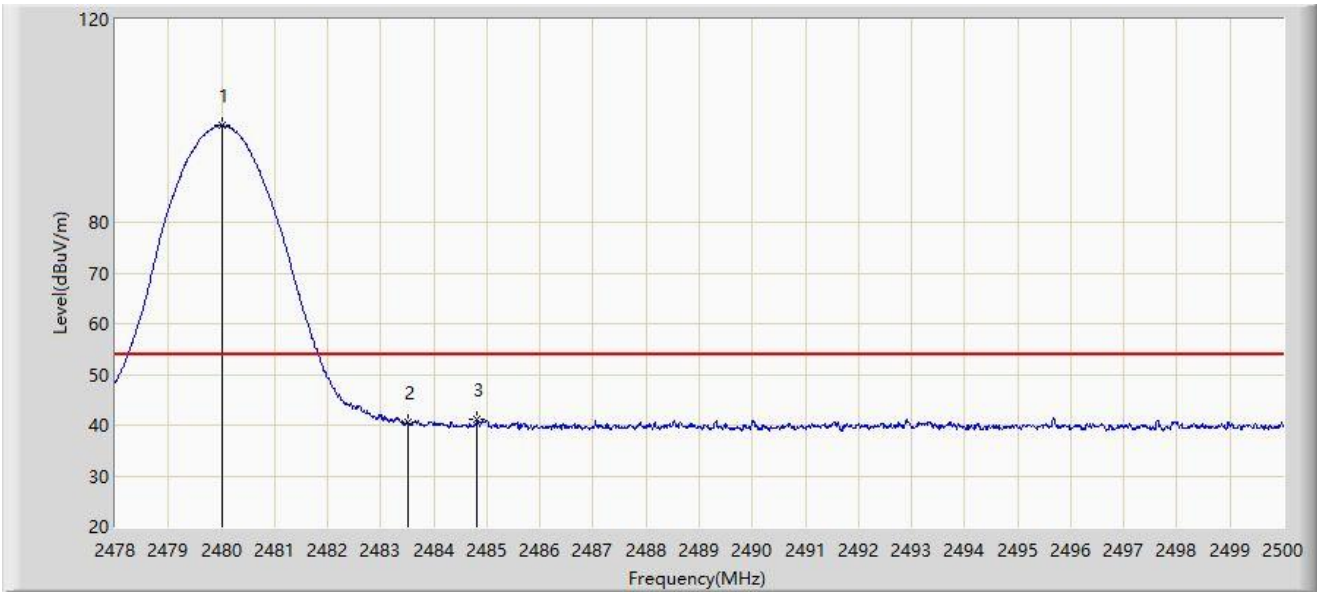

No	Mark	Frequency (MHz)	Measure Level (dBμV/m)	Reading Level (dBμV)	Margin (dB)	Limit (dBμV/m)	Factor (dB/m)	Type
1		2480.002	99.082	67.583	N/A	N/A	31.499	AV
2		2483.500	40.525	9.025	-13.475	54.000	31.500	AV
3	*	2484.809	41.093	9.592	-12.907	54.000	31.501	AV

Note 1: " \* ", means this data is the worst emission level.

Note 2: Measure Level (dBμV/m) = Reading Level (dBμV) + Factor (dB/m).

Note 3: Factor (dB/m) = Cable Loss (dB) + Antenna Factor (dB/m).

Site: WZ-AC2	Test Date: 2023-07-25
Limit: FCC_2.4G_RE(3m)	Engineer: Dick Shen
Probe: BBHA9120D_1457_1-18GHz	Polarity: Vertical
EUT: HPE Aruba User Experience Sensor	Power: AC 120V/60Hz
Test Mode: Transmit by BLE 1Mbps at 2480MHz	

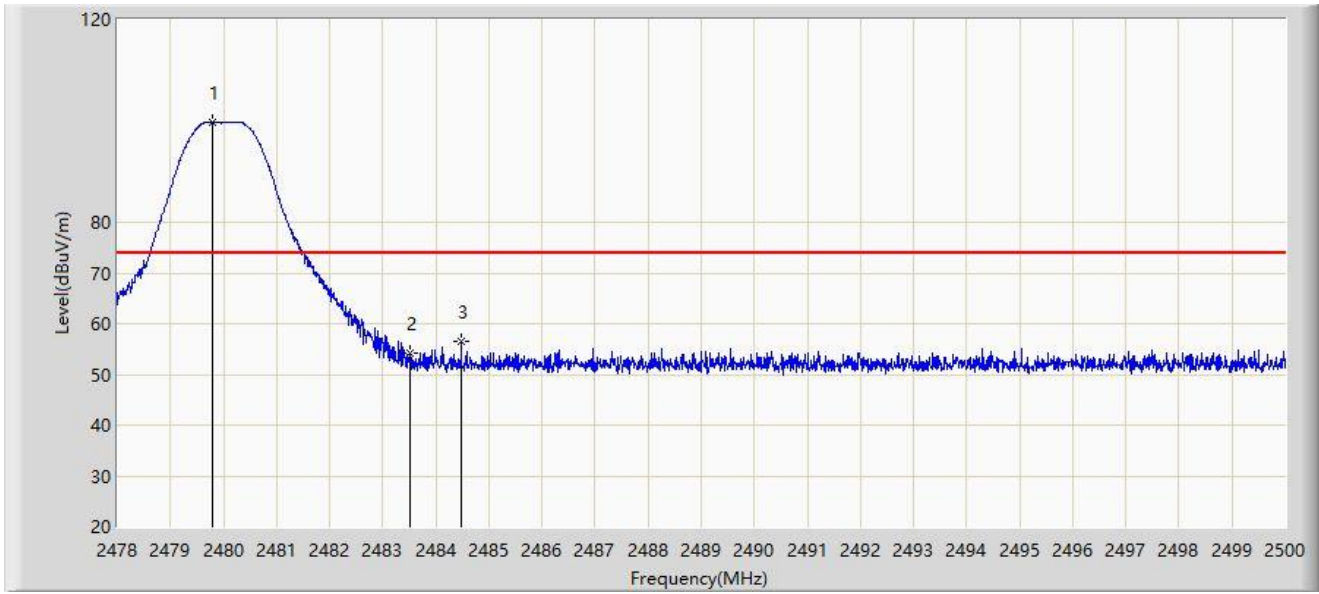

No	Mark	Frequency (MHz)	Measure Level (dB $\mu$ V/m)	Reading Level (dB $\mu$ V)	Margin (dB)	Limit (dB $\mu$ V/m)	Factor (dB/m)	Type
1		2479.804	99.757	68.258	N/A	N/A	31.499	PK
2		2483.500	54.221	22.721	-19.779	74.000	31.500	PK
3	*	2484.479	56.662	25.161	-17.338	74.000	31.501	PK

Note 1: " \* ", means this data is the worst emission level.

Note 2: Measure Level (dB $\mu$ V/m) = Reading Level (dB $\mu$ V) + Factor (dB/m).

Note 3: Factor (dB/m) = Cable Loss (dB) + Antenna Factor (dB/m).

Site: WZ-AC2	Test Date: 2023-07-25
Limit: FCC_2.4G_RE(3m)	Engineer: Dick Shen
Probe: BBHA9120D_1457_1-18GHz	Polarity: Vertical
EUT: HPE Aruba User Experience Sensor	Power: AC 120V/60Hz
Test Mode: Transmit by BLE 1Mbps at 2480MHz	

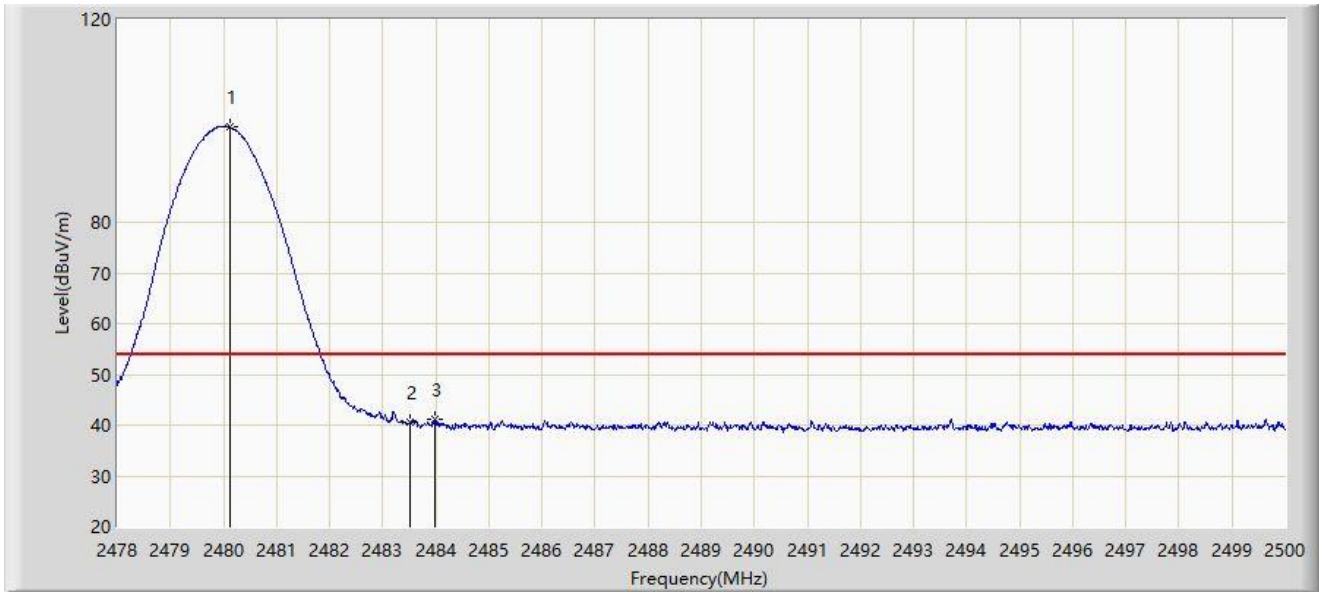

No	Mark	Frequency (MHz)	Measure Level (dB $\mu$ V/m)	Reading Level (dB $\mu$ V)	Margin (dB)	Limit (dB $\mu$ V/m)	Factor (dB/m)	Type
1		2480.112	98.841	67.342	N/A	N/A	31.499	AV
2		2483.500	40.480	8.980	-13.520	54.000	31.500	AV
3	*	2483.984	41.016	9.515	-12.984	54.000	31.501	AV

Note 1: " \* ", means this data is the worst emission level.

Note 2: Measure Level (dB $\mu$ V/m) = Reading Level (dB $\mu$ V) + Factor (dB/m).

Note 3: Factor (dB/m) = Cable Loss (dB) + Antenna Factor (dB/m).



Site: WZ-AC2	Test Date: 2023-07-25
Limit: FCC_2.4G_RE(3m)	Engineer: Dick Shen
Probe: BBHA9120D_1457_1-18GHz	Polarity: Horizontal
EUT: HPE Aruba User Experience Sensor	Power: AC 120V/60Hz
Test Mode: Transmit by BLE 2Mbps at 2402MHz	

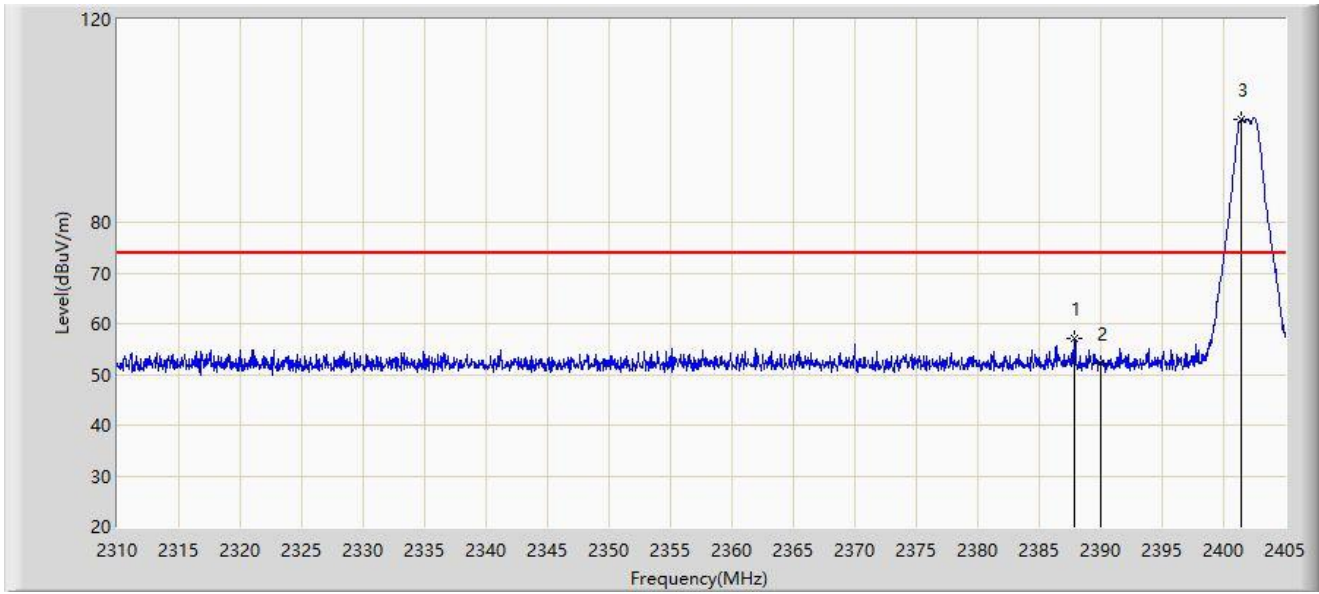

No	Mark	Frequency (MHz)	Measure Level (dB $\mu$ V/m)	Reading Level (dB $\mu$ V)	Margin (dB)	Limit (dB $\mu$ V/m)	Factor (dB/m)	Type
1	*	2387.805	57.123	25.494	-16.877	74.000	31.629	PK
2		2390.000	52.289	20.674	-21.711	74.000	31.615	PK
3		2401.437	100.422	68.870	N/A	N/A	31.552	PK

Note 1: " \* ", means this data is the worst emission level.

Note 2: Measure Level (dB $\mu$ V/m) = Reading Level (dB $\mu$ V) + Factor (dB/m).

Note 3: Factor (dB/m) = Cable Loss (dB) + Antenna Factor (dB/m).

Site: WZ-AC2	Test Date: 2023-07-25
Limit: FCC_2.4G_RE(3m)	Engineer: Dick Shen
Probe: BBHA9120D_1457_1-18GHz	Polarity: Horizontal
EUT: HPE Aruba User Experience Sensor	Power: AC 120V/60Hz
Test Mode: Transmit by BLE 2Mbps at 2402MHz	

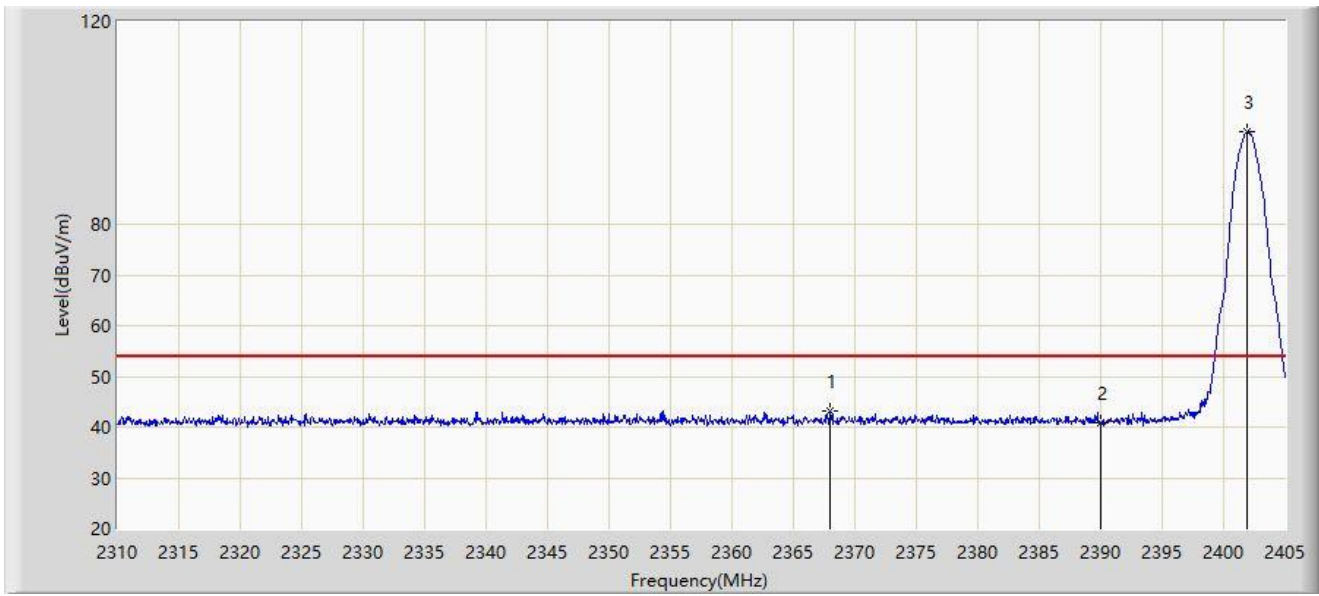

No	Mark	Frequency (MHz)	Measure Level (dB $\mu$ V/m)	Reading Level (dB $\mu$ V)	Margin (dB)	Limit (dB $\mu$ V/m)	Factor (dB/m)	Type
1	*	2367.950	43.147	11.465	-10.853	54.000	31.682	AV
2		2390.000	40.751	9.136	-13.249	54.000	31.615	AV
3		2401.865	98.140	66.590	N/A	N/A	31.550	AV

Note 1: " \* ", means this data is the worst emission level.

Note 2: Measure Level (dB $\mu$ V/m) = Reading Level (dB $\mu$ V) + Factor (dB/m).

Note 3: Factor (dB/m) = Cable Loss (dB) + Antenna Factor (dB/m).

Site: WZ-AC2	Test Date: 2023-07-25
Limit: FCC_2.4G_RE(3m)	Engineer: Dick Shen
Probe: BBHA9120D_1457_1-18GHz	Polarity: Vertical
EUT: HPE Aruba User Experience Sensor	Power: AC 120V/60Hz
Test Mode: Transmit by BLE 2Mbps at 2402MHz	

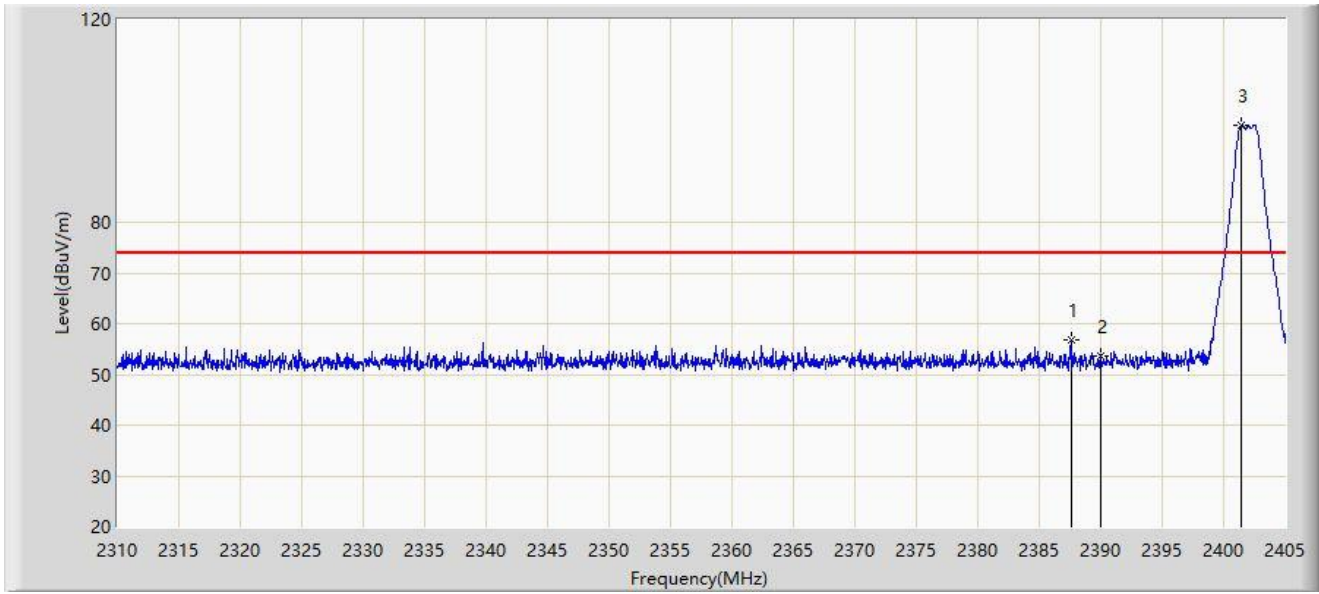

No	Mark	Frequency (MHz)	Measure Level (dB $\mu$ V/m)	Reading Level (dB $\mu$ V)	Margin (dB)	Limit (dB $\mu$ V/m)	Factor (dB/m)	Type
1	*	2387.567	56.721	25.091	-17.279	74.000	31.631	PK
2		2390.000	53.556	21.941	-20.444	74.000	31.615	PK
3		2401.485	99.083	67.531	N/A	N/A	31.552	PK

Note 1: " \* ", means this data is the worst emission level.

Note 2: Measure Level (dB $\mu$ V/m) = Reading Level (dB $\mu$ V) + Factor (dB/m).

Note 3: Factor (dB/m) = Cable Loss (dB) + Antenna Factor (dB/m).

Site: WZ-AC2	Test Date: 2023-07-25
Limit: FCC_2.4G_RE(3m)	Engineer: Dick Shen
Probe: BBHA9120D_1457_1-18GHz	Polarity: Vertical
EUT: HPE Aruba User Experience Sensor	Power: AC 120V/60Hz
Test Mode: Transmit by BLE 2Mbps at 2402MHz	

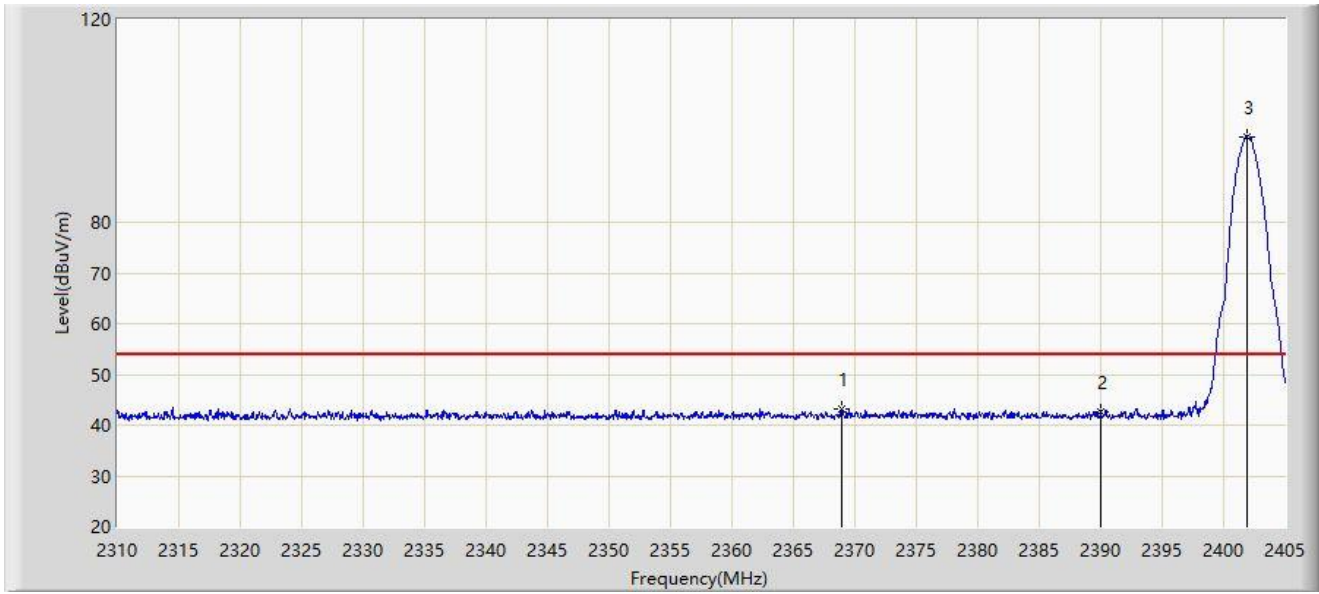

No	Mark	Frequency (MHz)	Measure Level (dB $\mu$ V/m)	Reading Level (dB $\mu$ V)	Margin (dB)	Limit (dB $\mu$ V/m)	Factor (dB/m)	Type
1	*	2368.900	43.217	11.537	-10.783	54.000	31.680	AV
2		2390.000	42.520	10.905	-11.480	54.000	31.615	AV
3		2401.865	96.900	65.350	N/A	N/A	31.550	AV

Note 1: " \* ", means this data is the worst emission level.

Note 2: Measure Level (dB $\mu$ V/m) = Reading Level (dB $\mu$ V) + Factor (dB/m).

Note 3: Factor (dB/m) = Cable Loss (dB) + Antenna Factor (dB/m).

Site: WZ-AC1	Test Date: 2023-08-11
Limit: FCC_2.4G_RE(3m)	Engineer: Ajin Fan
Probe: BBHA9120D_1167_1-18GHz	Polarity: Horizontal
EUT: HPE Aruba User Experience Sensor	Power: AC 120V/60Hz
Test Mode: Transmit by BLE 2Mbps at 2480MHz	

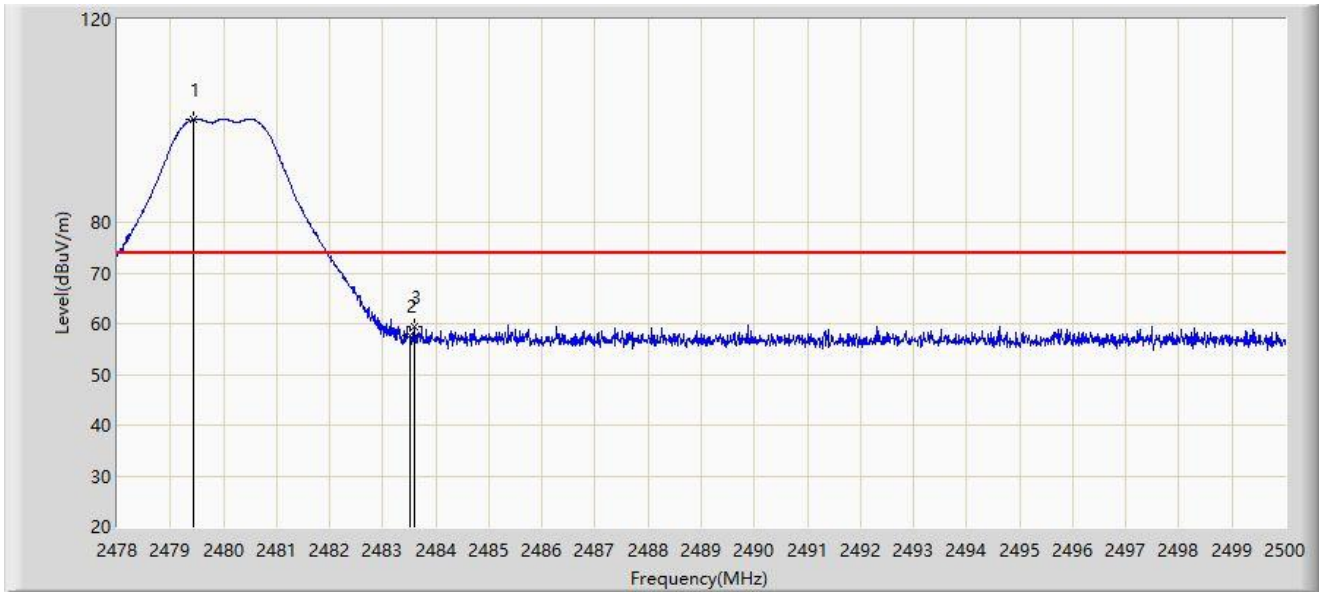

No	Mark	Frequency (MHz)	Measure Level (dB $\mu$ V/m)	Reading Level (dB $\mu$ V)	Margin (dB)	Limit (dB $\mu$ V/m)	Factor (dB/m)	Type
1		2479.441	100.308	69.219	N/A	N/A	31.089	PK
2		2483.500	57.775	26.682	-16.225	74.000	31.093	PK
3	*	2483.588	59.522	28.429	-14.478	74.000	31.093	PK

Note 1: " \* ", means this data is the worst emission level.

Note 2: Measure Level (dB $\mu$ V/m) = Reading Level (dB $\mu$ V) + Factor (dB/m).

Note 3: Factor (dB/m) = Cable Loss (dB) + Antenna Factor (dB/m).

Site: WZ-AC1	Test Date: 2023-08-11
Limit: FCC_2.4G_RE(3m)	Engineer: Ajin Fan
Probe: BBHA9120D_1167_1-18GHz	Polarity: Horizontal
EUT: HPE Aruba User Experience Sensor	Power: AC 120V/60Hz
Test Mode: Transmit by BLE 2Mbps at 2480MHz	

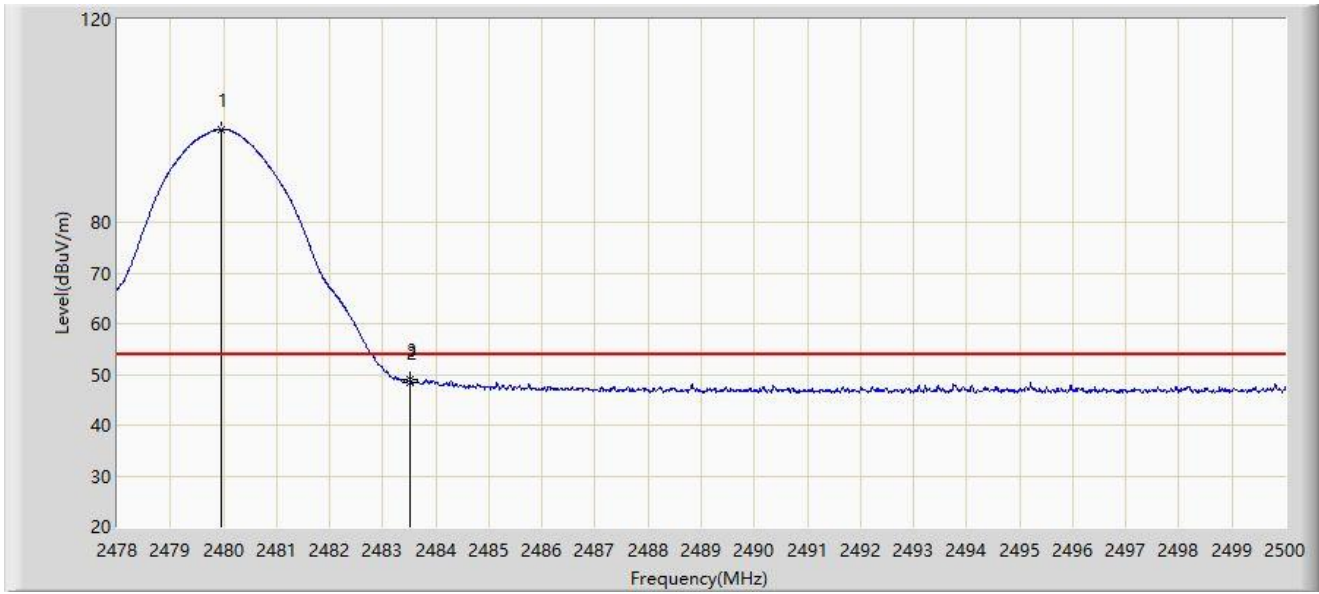

No	Mark	Frequency (MHz)	Measure Level (dBμV/m)	Reading Level (dBμV)	Margin (dB)	Limit (dBμV/m)	Factor (dB/m)	Type
1		2479.958	98.336	67.246	N/A	N/A	31.090	AV
2		2483.500	48.530	17.437	-5.470	54.000	31.093	AV
3	*	2483.511	49.060	17.967	-4.940	54.000	31.093	AV

Note 1: " \* ", means this data is the worst emission level.

Note 2: Measure Level (dBμV/m) = Reading Level (dBμV) + Factor (dB/m).

Note 3: Factor (dB/m) = Cable Loss (dB) + Antenna Factor (dB/m).

Site: WZ-AC1	Test Date: 2023-08-11
Limit: FCC_2.4G_RE(3m)	Engineer: Ajin Fan
Probe: BBHA9120D_1167_1-18GHz	Polarity: Vertical
EUT: HPE Aruba User Experience Sensor	Power: AC 120V/60Hz
Test Mode: Transmit by BLE 2Mbps at 2480MHz	

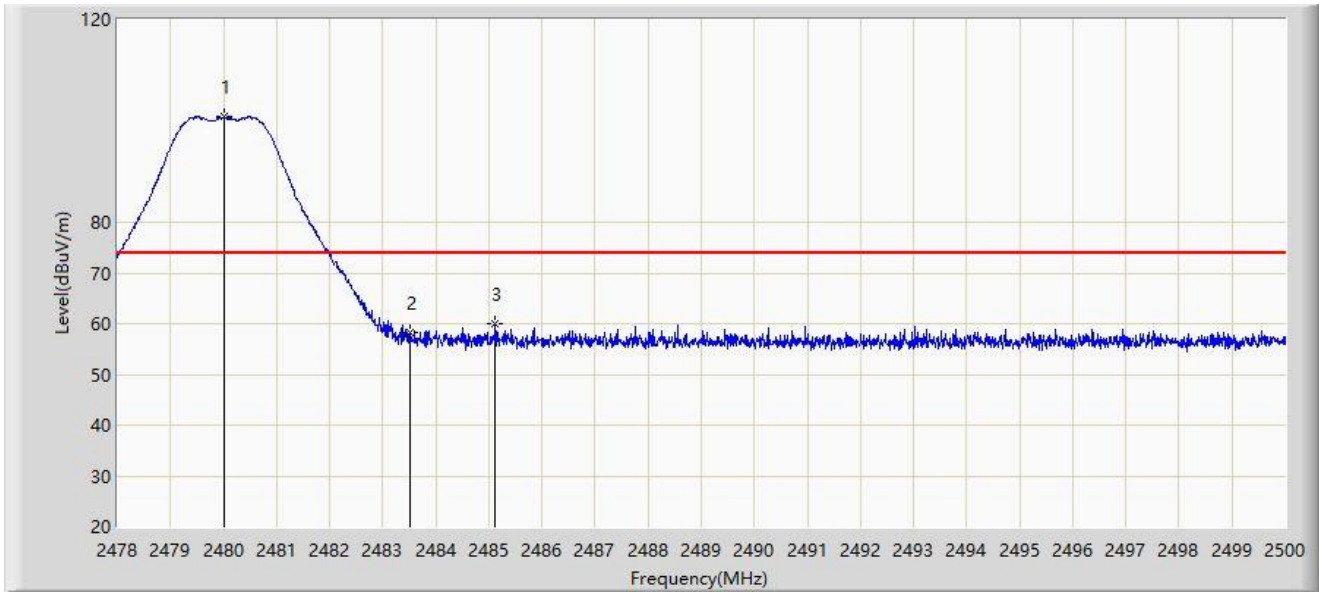

No	Mark	Frequency (MHz)	Measure Level (dB $\mu$ V/m)	Reading Level (dB $\mu$ V)	Margin (dB)	Limit (dB $\mu$ V/m)	Factor (dB/m)	Type
1		2480.024	100.784	69.694	N/A	N/A	31.090	PK
2		2483.500	58.379	27.286	-15.621	74.000	31.093	PK
3	*	2485.117	59.890	28.796	-14.110	74.000	31.094	PK

Note 1: " \* ", means this data is the worst emission level.

Note 2: Measure Level (dB $\mu$ V/m) = Reading Level (dB $\mu$ V) + Factor (dB/m).

Note 3: Factor (dB/m) = Cable Loss (dB) + Antenna Factor (dB/m).

Site: WZ-AC1	Test Date: 2023-08-11
Limit: FCC_2.4G_RE(3m)	Engineer: Ajin Fan
Probe: BBHA9120D_1167_1-18GHz	Polarity: Vertical
EUT: HPE Aruba User Experience Sensor	Power: AC 120V/60Hz
Test Mode: Transmit by BLE 2Mbps at 2480MHz	

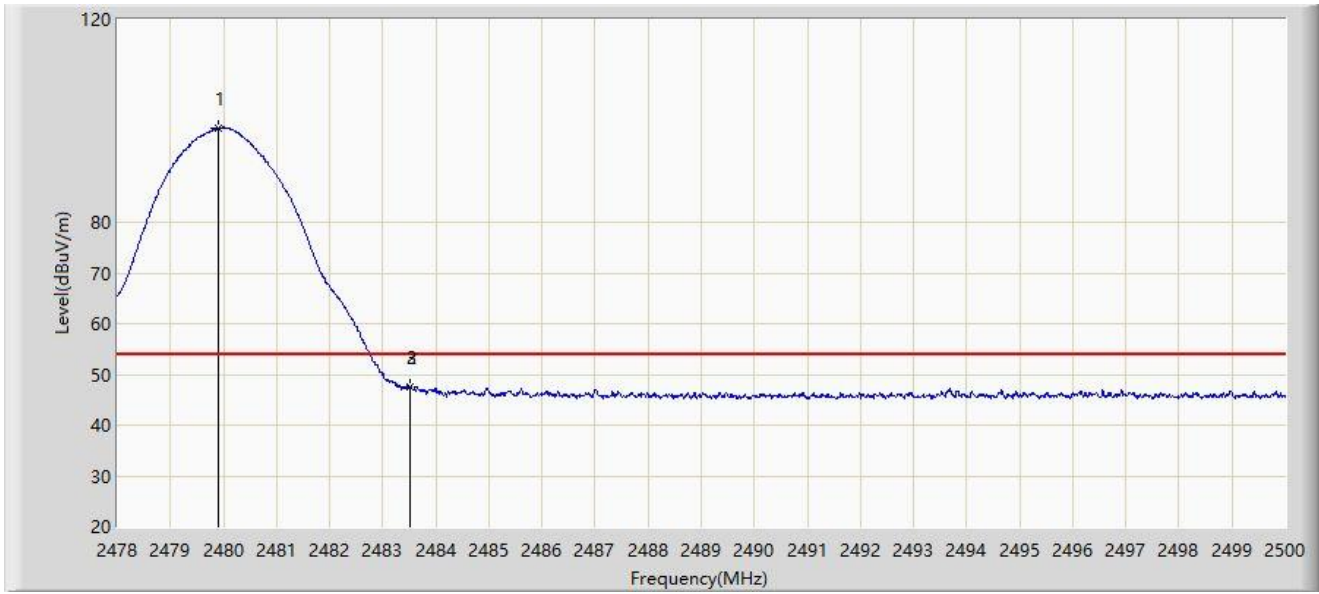

No	Mark	Frequency (MHz)	Measure Level (dB $\mu$ V/m)	Reading Level (dB $\mu$ V)	Margin (dB)	Limit (dB $\mu$ V/m)	Factor (dB/m)	Type
1		2479.914	98.612	67.522	N/A	N/A	31.090	AV
2		2483.500	47.527	16.434	-6.473	54.000	31.093	AV
3	*	2483.522	47.571	16.478	-6.429	54.000	31.093	AV

Note 1: " \* ", means this data is the worst emission level.

Note 2: Measure Level (dB $\mu$ V/m) = Reading Level (dB $\mu$ V) + Factor (dB/m).

Note 3: Factor (dB/m) = Cable Loss (dB) + Antenna Factor (dB/m).



### A.8 AC Conducted Emissions Test Result

Site: WZ-SR2	Test Date: 2023-08-07
Limit: FCC_Part15.207_CE_AC Power	Engineer: Linda Wei
Probe: ENV216_101683_Filter Off_E	Polarity: Line
EUT: HPE Aruba User Experience Sensor	Power: AC 120V/60Hz
Test Mode: Transmit by BLE 1Mbps at 2440MHz	

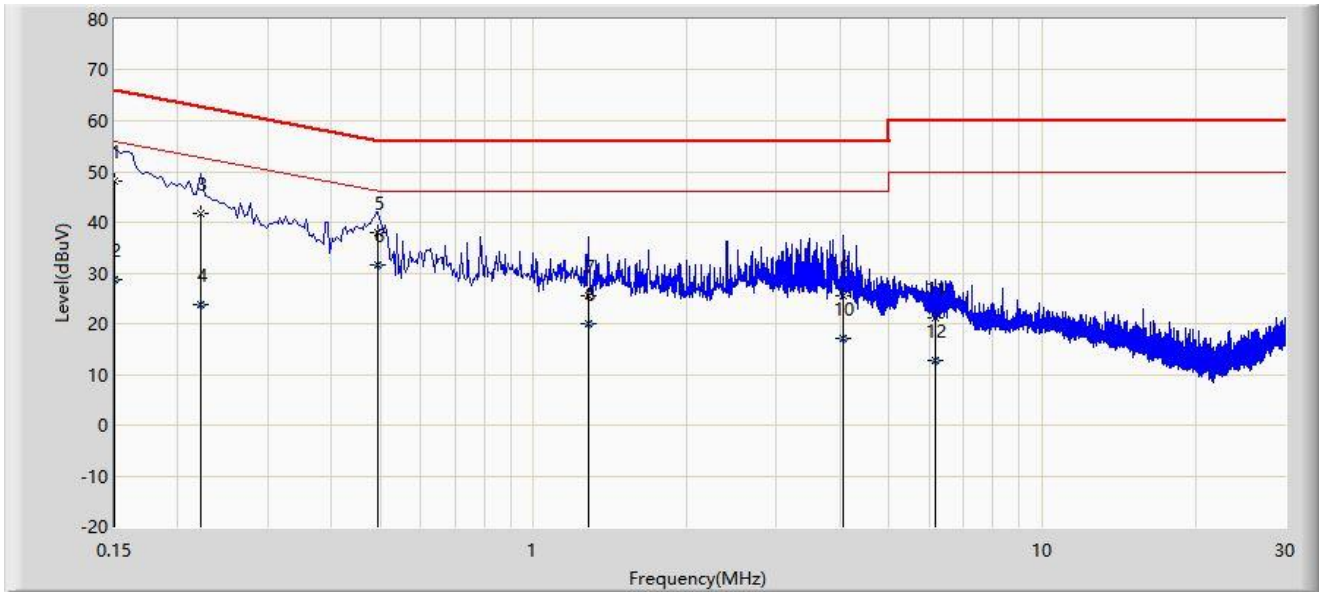

No	Mark	Frequency (MHz)	Measure Level (dBμV)	Reading Level (dBμV)	Margin (dB)	Limit (dBμV)	Factor (dB)	Type
1		0.150	48.207	38.442	-17.793	66.000	9.766	QP
2		0.150	28.820	19.055	-27.180	56.000	9.766	AV
3		0.222	41.869	32.073	-20.875	62.744	9.797	QP
4		0.222	23.823	14.027	-28.921	52.744	9.797	AV
5		0.494	38.076	28.149	-18.024	56.100	9.928	QP
6	*	0.494	31.633	21.706	-14.467	46.100	9.928	AV
7		1.282	25.582	15.318	-30.418	56.000	10.264	QP
8		1.282	20.033	9.768	-25.967	46.000	10.264	AV
9		4.070	25.407	14.721	-30.593	56.000	10.686	QP
10		4.070	16.977	6.291	-29.023	46.000	10.686	AV
11		6.170	21.059	10.149	-38.941	60.000	10.910	QP
12		6.170	12.612	1.702	-37.388	50.000	10.910	AV

Note 1: " \* ", means this data is the worst emission level.

Note 2: Measure Level (dBμV) = Reading Level (dBμV) + Factor (dB).

Note 3: Factor (dB) = Cable Loss (dB) + LISN Factor (dB).

Site: WZ-SR2	Test Date: 2023-08-07
Limit: FCC_Part15.207_CE_AC Power	Engineer: Linda Wei
Probe: ENV216_101683_Filter Off_E	Polarity: Neutral
EUT: HPE Aruba User Experience Sensor	Power: AC 120V/60Hz
Test Mode: Transmit by BLE 1Mbps at 2440MHz	

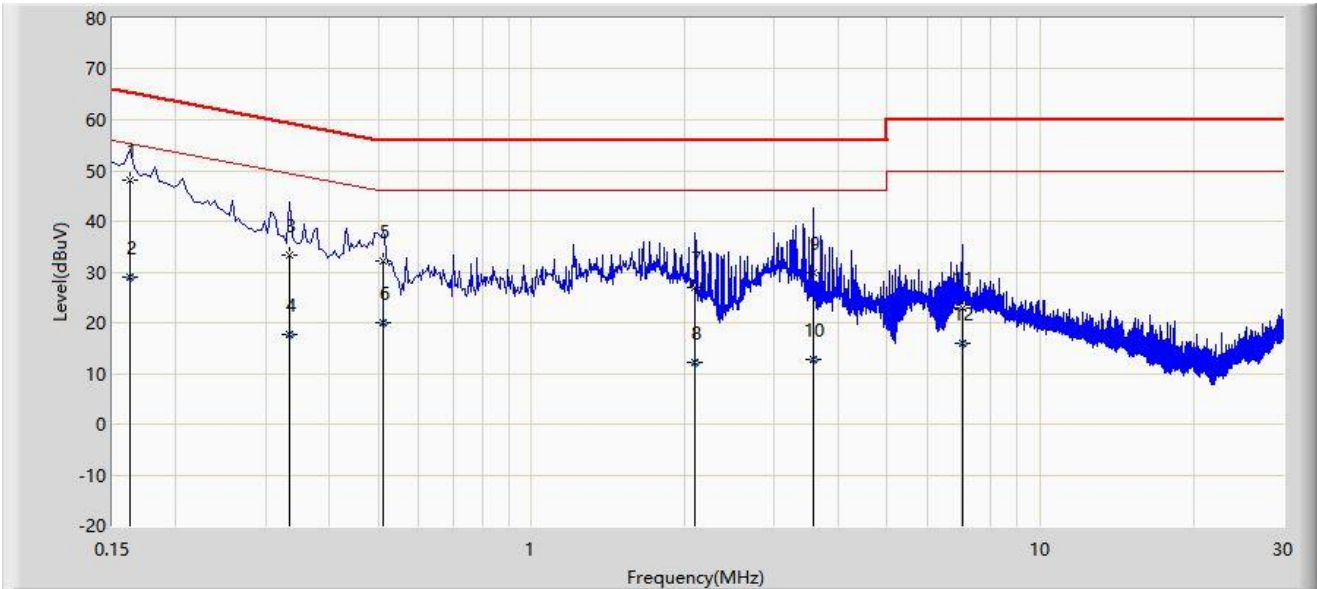

No	Mark	Frequency (MHz)	Measure Level (dB $\mu$ V)	Reading Level (dB $\mu$ V)	Margin (dB)	Limit (dB $\mu$ V)	Factor (dB)	Type
1	*	0.162	48.024	38.247	-17.337	65.361	9.777	QP
2		0.162	28.960	19.183	-26.401	55.361	9.777	AV
3		0.334	33.380	23.534	-25.971	59.351	9.846	QP
4		0.334	17.789	7.943	-31.562	49.351	9.846	AV
5		0.510	32.147	22.200	-23.853	56.000	9.947	QP
6		0.510	20.000	10.053	-26.000	46.000	9.947	AV
7		2.098	26.992	16.556	-29.008	56.000	10.436	QP
8		2.098	12.076	1.641	-33.924	46.000	10.436	AV
9		3.574	29.737	18.947	-26.263	56.000	10.790	QP
10		3.574	12.720	1.929	-33.280	46.000	10.790	AV
11		7.026	22.813	11.555	-37.187	60.000	11.259	QP
12		7.026	15.894	4.635	-34.106	50.000	11.259	AV

Note 1: " \* ", means this data is the worst emission level.

Note 2: Measure Level (dB $\mu$ V) = Reading Level (dB $\mu$ V) + Factor (dB).

Note 3: Factor (dB) = Cable Loss (dB) + LISN Factor (dB).

## **Appendix B - Test Setup Photograph**

Refer to "2306RSU027-UT" file.

## Appendix C - EUT Photograph

Refer to "2306RSU027-UE" file.

\_\_\_\_\_ The End \_\_\_\_\_