

Aruba 9004 Gateway



Installation Guide

Copyright

Copyright Information© Copyright 2019 Hewlett Packard Enterprise Development LP.

Open Source Code

This product includes code licensed under the GNU General Public License, the GNU Lesser General Public License, and/or certain other open source licenses. A complete machine-readable copy of the source code corresponding to such code is available upon request. This offer is valid to anyone in receipt of this information and shall expire three years following the date of the final distribution of this product version by Hewlett Packard Enterprise Company. To obtain such source code, send a check or money order in the amount of US \$10.00 to:

Hewlett Packard Enterprise Company
Attn: General Counsel
3000 Hanover Street
Palo Alto, CA 94304
USA



www.arubanetworks.com

Hewlett Packard Enterprise Company
Attn: General Counsel
3000 Hanover Street
Palo Alto, CA 94304 USA

Phone: 408.227.4500
Fax 408.227.4550

Preface	5
Guide Overview.....	5
Related Documentation.....	5
Contacting Support	5
9004 Gateway	7
Package Checklist	7
Aruba 9004 Gateway Components	7
DC Power Connector	8
Reset Switch	9
Ethernet Ports	9
Console Port	9
Micro-USB Console Connector.....	11
USB Interface.....	11
Front Panel LEDs.....	11
Kensington Security Slot	13
DC Power Socket.....	13
Installation	15
Installation Recommendations.....	15
Installation Using the Integrated Wall-Mounting Slots	15
Specifications, Safety, and Compliance	19
Aruba 9004 Gateway Specifications	19
Physical	19
Electrical.....	19
Environmental.....	19
Safety and Regulatory Compliance	19
FCC Class B Part 15.....	19
EU Regulatory Conformance	20
Wireless Channel Restrictions.....	21
Japan VCCI.....	21
Regulatory Model Name	21
Proper Disposal of Aruba Equipment.....	21
Waste of Electrical and Electronic Equipment.....	21
European Union RoHS.....	22
India RoHS	22
China RoHS	22
Korean.....	22
Taiwan.....	22
Нормативные требования Евразийского Экономического Союза	23
Mexico.....	23

This document describes the hardware features of the Aruba 9004 gateway. It provides a detailed overview of the physical and performance characteristics of the gateway and explains how to install the gateway and its accessories.

Guide Overview

- [Chapter 1, “9004 Gateway” on page 7](#) provides a detailed hardware overview of the Aruba 9004 gateway and each of its components.
- [Chapter 2, “Installation” on page 15](#) describes how to install the Aruba 9004 gateway.
- [Chapter 3, “Specifications, Safety, and Compliance” on page 19](#) lists the Aruba 9004 gateway’s technical specifications and safety and regulatory compliance information.

Related Documentation

The latest ArubaOS User Guide and ArubaOS CLI Reference Guide are required for the complete management of an Aruba gateway. The latest documentation and the translation of this document into other languages can be found at www.arubanetworks.com/documentation.

Contacting Support

Table 1 *Contact Information*

Main Site	www.arubanetworks.com
Support Site	http://support.arubanetworks.com
Airheads Social Forums and Knowledge Base	www.community.arubanetworks.com
North American Telephone	1-800-943-4526 (Toll Free) 1-408-754-1200
International Telephones	https://www.arubanetworks.com/support-services/contact-support/
Software Licensing Site	www.hpe.com/networking/support
End of Support information	www.arubanetworks.com/support-services/end-of-life/end-of-life-policy/
Security Incident Response Team (SIRT)	Site: https://www.arubanetworks.com/support-services/security-bulletins/ Email: aruba-sirt@hpe.com

The Aruba 9004 gateway is a wireless LAN gateway that connects, controls, and intelligently integrates wireless Access Points (APs), Managed Devices, and Air Monitors (AMs).

The Aruba 9004 gateway has the following port configuration:

Table 2 Aruba 9004 Gateway Port Configuration

Model	Ports	Number of APs Supported	Number of Users Supported
9004	<ul style="list-style-type: none"> 4 x 100/1000BASE-T ports 1 x USB 3.0 port RJ45 console port Micro USB console port 	32	2000



The Aruba 9004 gateway requires ArubaOS 8.5.0.0 or later versions.

Package Checklist

Inform your supplier if there are any incorrect, missing, or damaged parts. To return this product, repack this unit and other materials included into the original packaging, before returning it to the supplier.

Table 3 Package Contents

Item	Quantity
Aruba 9004 gateway	1
Micro USB console cable	1
Power adapter	1
Aruba 9004 Start-up Guide (Printed)	1
Adapter cable saddle	1



Optional accessories are available for use with the Aruba 9004 gateway and are sold separately. Contact your Aruba sales representative for details and assistance.

Aruba 9004 Gateway Components

This section introduces the different component and its location in the Aruba 9004 gateway.

Figure 1 shows the front panel of the Aruba 9004 gateway and Figure 2 shows the back panel of the Aruba 9004 gateway.

Figure 1 Front Panel of the Aruba 9004 gateway

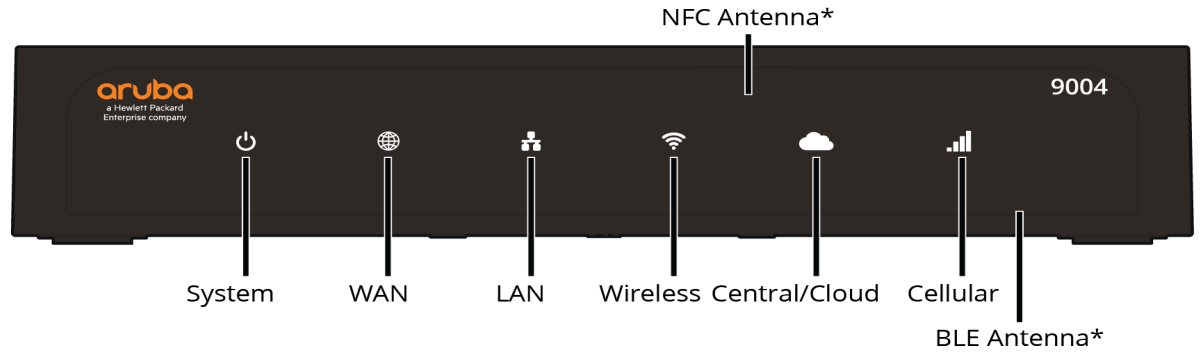

* The antenna is integrated within the hardware and is not displayed on the front panel.

Figure 2 Back Panel of the Aruba 9004 gateway

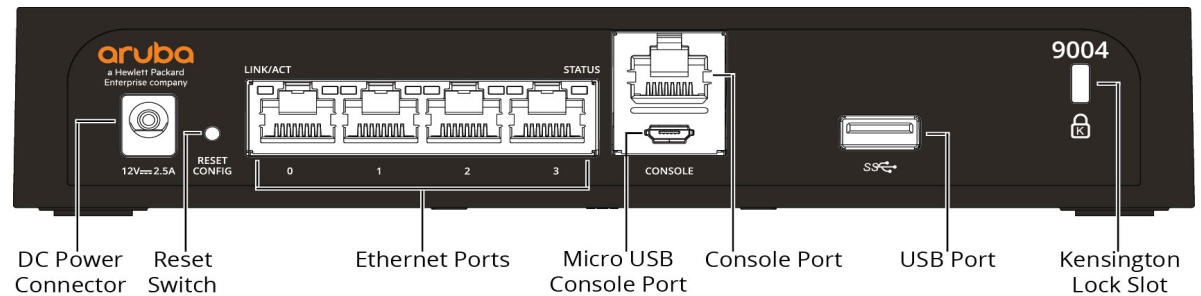

Front Panel LEDs

The front panel LEDs show the System, WAN, and LAN status including various other features. These front panel LEDs provide basic monitoring information of the overall status of the Aruba 9004 gateway. The following table describes the LED indicators and their corresponding status:

Table 4 LED Status

LED	Function	Indicator	Status
System	System status	Green (Solid)	Powered and Operational
		Green (Blinking)	Loading Software
		Amber (Solid)	Critical Alarm
		Amber (Blinking)	Major Alarm
		Off	Power Off
WAN	Link Status	Green (Solid)	All WAN Ports Established
		Amber (Solid)	No WAN Ports Established
LAN	Link Status	Green (Solid)	All LAN Ports Established
		Amber (Solid)	No LAN Ports Established

Table 4 LED Status

LED	Function	Indicator	Status
Wireless	Wireless LAN Controller Status	Green (Solid)	The WLAN Controller is Up and Functioning.
		Green (Blinking)	WLAN Gateway Booting
Central/Cloud	Central Connectivity Status		
Cellular	Link Status	Green (Solid)	Modem Initialized and Connected to the Network. Good Signal Strength. Signal Strength Threshold: > -65 dBm
		Green (Blinking)	Modem Initializing
		Green + Amber (Greenish Yellow) (Solid)	Modem Initialized and Connected to the Network. Average Signal Strength. Signal Strength Threshold: < -65 dBm > -80 dBm
		Amber (Solid)	Modem Initialized and Connected to the Network. Poor Signal Strength. Signal Strength Threshold: < -80 dBm
		Amber (Blinking)	Network Connection Failure. SIM Removal. Modem not Responding to Web Commands.
		Red (Solid)	Modem Lost IP Address or Disconnected from the Network. Acting as a Backup Uplink.
		Red (Blinking)	Hardware Failure. USB Failure. Unsupported USB Device Attached.

DC Power Connector

The AC-DC adapter kit with the following specification is used to power the Aruba 9004 gateway:

- 12V/2A power interface
- Center-positive 2.1/5.5 mm circular plug, 9.5 mm length

Reset Switch

The Aruba 9004 gateway includes a recessed button for resetting the gateway configurations. Insert a pin into the Reset Switch hole until you feel the pin touches a surface. Push and hold the pin for two seconds to reset the controller configuration.

Ethernet Ports

The Aruba 9004 gateway is equipped with four 100/1000BASE-T Gigabit Ethernet ports (0 to 3). Gigabit Ethernet uses all eight wires and each pair is bidirectional, which means, the same pair is used for both data transmission and reception. [Figure 3](#) illustrates the Gigabit Ethernet port pin-

out for an RJ-45 connector. The pins paired on a 100/1000Base-T Gigabit Ethernet port are: 1/2, 3/6, 4/5, and 7/8.

Figure 3 *Figure 3 Gigabit Ethernet Port Pin-Out*

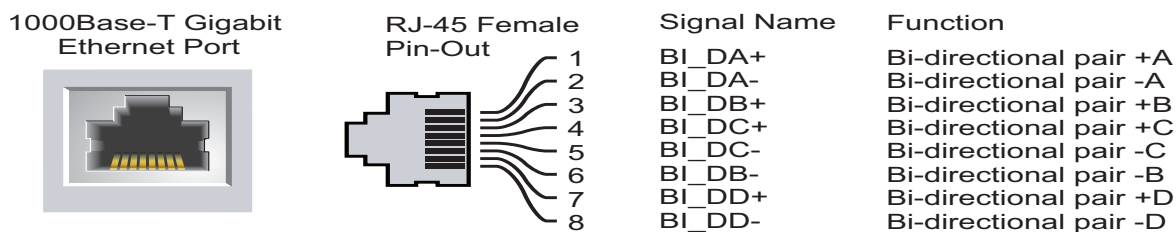

Ethernet Port LEDs

Each 100/1000BASE-T Ethernet port is equipped with two LEDs that allow basic monitoring of link/port status and activity.

- **LINK/ACT:** Placed on the left side of the port, and displays the link status and activity of the port.
- **STATUS:** Placed on the right side of the port, and displays the status of the port based on the CLI.

The following table describes the LED behavior for each mode:

Table 5 *100/1000BASE-T Ethernet Port LEDs*

LED	Function	Mode	Indicator	Status
LINK/ACT	Link status	NA	Green (Solid)	Link established
			Green (Blinking)	Port is transmitting or receiving data
			Off	No link
STATUS	Port status	Speed	Green (Solid)	Link at 1000 Mbps
			Off	Link at 100 Mbps

Micro-USB Console Port

The Aruba 9004 gateway is equipped with a Micro-USB (type B) connector that provides console access for direct local access. If both Micro-USB and RJ-45 console ports are connected, the Micro-USB connection takes precedence over the RJ-45 console connection.

Micro-USB Driver

To use the Micro-USB console port, you must install the Aruba Micro-USB driver on the computer that will manage your gateway. To download the driver, perform the following steps:

1. Go to <https://support.arubanetworks.com>.
2. Click on the **Tools & Resources** tab.
3. Open the **USB Console Driver** folder.
4. Open the **Mobility Gateway and Mobility Access Switch** folder.

Select the appropriate file for your application. The corresponding operating system is in the file name.

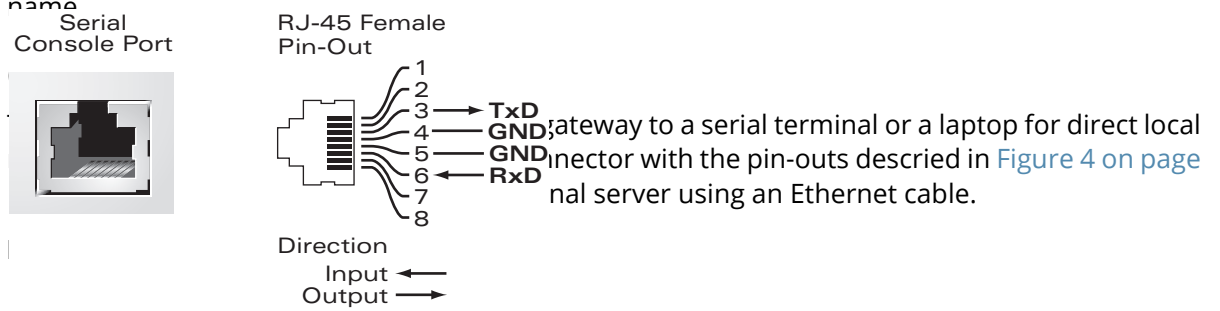

The communication settings for the Console port is shown in the following table:

Table 6 Console Terminal Settings

Baud Rate	Data Bits	Parity	Stop Bits	Flow Control
9600	8	None	1	None



The CONSOLE port is compatible only with RS-232 devices. Non-RS-232 devices, such as APs, are not supported.



Do not connect the Console port to an Ethernet switch or a PoE power source. This may damage the gateway.

Serial Console Port Adapter

A modular adapter can be used to convert the female RJ-45 connector to a male DB9 connector. See Figure 5 for complete details.

Figure 5 RJ-45 (Female) to DB9 (Male) Modular Adapter Conversion

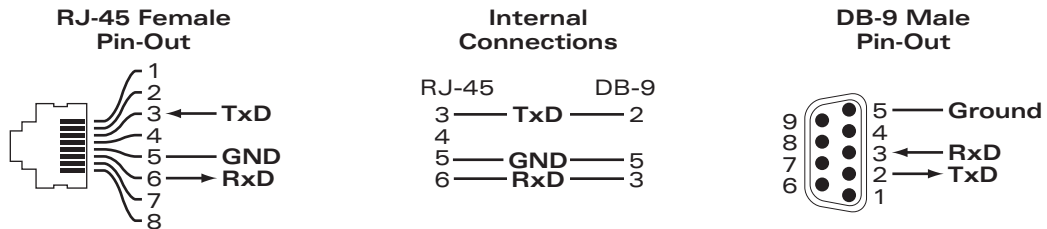

USB Port

The Aruba 9004 gateway is equipped with a USB 3.0 interface. A USB storage device can be used to save and upload configurations to the gateway.

Kensington Lock Slot

The Aruba 9004 gateway is equipped with a Kensington security slot for additional security.



Installation of the device should be performed by a trained installation professional.

Installation Recommendations

- For proper air circulation, leave at least 10 cm (4 inches) clearance on the left, right, front, and rear side of the gateway.
- Leave additional space in front and rear side of the gateway to access power cords, network cables, and indicator LEDs.
- Avoid placing anything on top of the gateway because it can lead to overheating of the gateway.
- Avoid placing this gateway on any other device because the heat dissipated from the other device can over heat the gateway.

Installation Using the Integrated Wall-Mounting Slots

The keyhole-shaped slots on the bottom of the gateway can be used to attach the device upright (back port facing downwards) to an indoor wall or shelf.

Make sure to mount the gateway in such a way that there is a clear path to the Ethernet port, such as a predrilled hole in the mounting surface.

1. At the mounting location, install two screws on the wall or shelf, 145.35 mm apart. If you are attaching the device to drywall, it is recommended that you use appropriate wall anchors (not included). See [Figure 6](#).
 - Use 3/4 inch long #6 pan head wood screws for mounting 9004 unit on wood.
 - Use 3/4 inch long #6 pan head wood screws with plastic screw anchor #6-8 x 1 inch on dry wall or concrete wall.
 - Required quantity: 2 screws per unit

Figure 6 *Mounting Using the Integrated Wall-Mounting Slots*

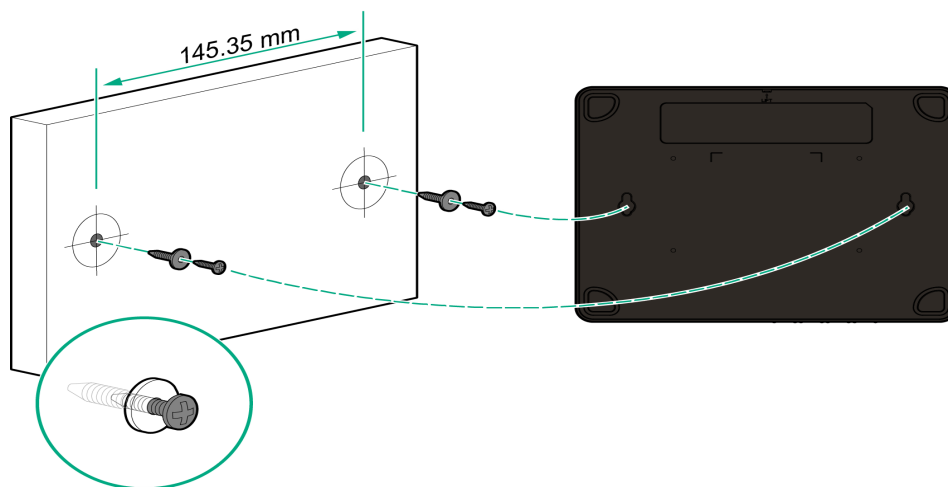

2. Align the mounting slots on the bottom of the gateway over the screws and slide the unit into place. See [Figure 7](#)

Figure 7 Wall Mounting Aruba 9004 Gateway

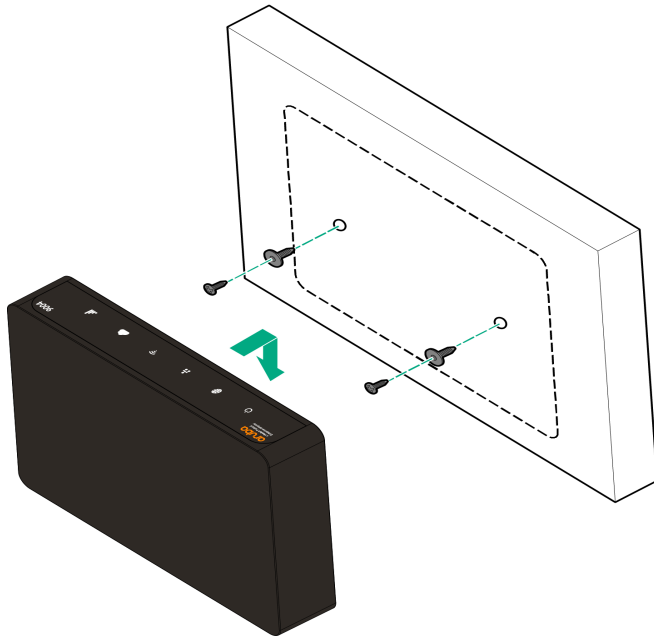

3. Align the cable saddle with the slot on the side of the gateway and push the cable saddle into the unit to secure it. See [Figure 8](#).

Figure 8 Attaching a cable saddle

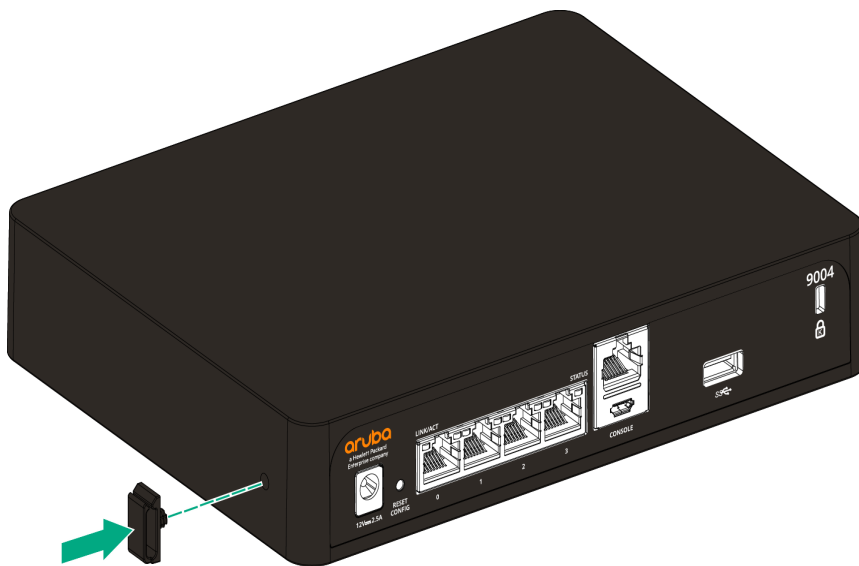

4. Insert the cable into the cable saddle and attach it to the power connector slot. This secures the cable and keeps it in place. See [Figure 9](#).

Figure 9 *Securing a cable*



Aruba 9004 Gateway Specifications

Physical

- Device Dimensions (without mounting brackets) (HxWxD): 3.82 cm x 19.85cm x 15.31 cm
- Device Weight: 2.723 lbs (1.235 kg)

Electrical

- Ethernet
 - 4 x 100/1000BASE-T auto-sensing Ethernet RJ-45 Interfaces
 - MDI/MDX
- Power
 - 12V DC power interface, supports powering through an 12V DC, 2.5A AC-to-DC power adapter.

Environmental

- Operating
 - Temperature Range: 0 °C to 40 °C (32 °F to 104 °F)
 - Humidity Range: 10% to 90% (RH), non-condensing
- Storage and Transportation
 - Temperature Range: -40 °C to 70 °C (-40 °F to 158 °F)
 - Humidity Range: 10% to 95% (RH), non-condensing

For additional specifications on this product, please refer to the data sheet. The data sheet can be found at www.arubanetworks.com

Safety and Regulatory Compliance

Aruba Networks, a Hewlett Packard Enterprise company provides a multi-language document that contains country-specific restrictions and additional safety and regulatory information for all Aruba products. This document can be viewed or downloaded from the following location:

www.arubanetworks.com/safety_addendum



Aruba gateways must be installed by a professional installer. The professional installer is responsible for ensuring that grounding is available and it meets applicable local and national electrical codes.



RF Radiation Exposure Statement: This equipment complies with RF radiation exposure limits. This equipment should be installed and operated with a minimum distance of 13.78 inches (35cm) between the radiator and your body for 2.4 GHz and 5 GHz operations. This transmitter must not be co-located or operating in conjunction with any other antenna or transmitter.



Déclaration sur les limites d'exposition aux radiofréquences : cet équipement est conforme aux limites d'exposition aux rayonnements radioélectriques spécifiées. Il doit être installé et utilisé à une distance minimale de 35 cm par rapport à votre corps pour les fréquences de 2,4 et 5 GHz. Cet émetteur-récepteur ne doit pas être utilisé ou situé à proximité d'autres antennes ou émetteurs-récepteurs.

FCC Class B Part 15

This device complies with Part 15 of the Federal Communications Commission (FCC) Rules. Operation is subject to the following two conditions:

- This device may not cause harmful interference.
- This device must accept any interference received, including interference that may cause undesired operation.



Changes or modifications to this unit not expressly approved by Aruba Networks, a Hewlett Packard Enterprise company could void the user's authority to operate this equipment.

This equipment has been tested and found to comply with the limits for a Class B digital device, pursuant to Part 15 of the FCC Rules. This equipment generates, uses and can radiate radio frequency energy and, if not installed and used in accordance with the manufacturer's instructions, may cause interference harmful to radio communications.

If this equipment does cause interference, which can be determined by turning the equipment off and on, the user is encouraged to try to correct the interference by one or more of the following measures:

- Reorient or relocate the receiving antenna.
- Increase the separation between the equipment and receiver.
- Connect the equipment to an outlet on a circuit different from that to which the receiver is connected.
- Consult the dealer or an experienced radio or TV technician for help.

Industry Canada

This Class B digital apparatus meets all of the requirements of the Canadian Interference-Causing Equipment Regulations.

This device complies with Industry Canada's license-exempt RSS regulations. Operation of this device is subject to the following two conditions: (1) this device may not cause interference, and (2) this device must accept any interference, including interference that may cause undesired operation.

Déclaration d'Industrie Canada

Conformément aux réglementations d'Industrie Canada, cet émetteur-récepteur radio doit être utilisé uniquement avec une antenne dont le type et le gain maximal doivent être approuvés par Industrie Canada.

Ce périphérique est conforme aux règlements RSS exempts de licence d'Industrie Canada. L'utilisation de ce périphérique est soumise aux deux conditions suivantes : (1) ce périphérique ne doit pas provoquer d'interférences, et (2) ce périphérique doit accepter toute interférence, y compris les interférences susceptibles de provoquer un dysfonctionnement.

EU Regulatory Conformance



The Declaration of Conformity made under RED Directive 2014/53/EU is available for viewing at <http://www.hpe.com/eu/certificates>. Select the document that corresponds to your device's model number as it is indicated on the product label.



Use of controls or adjustments of performance or procedures other than those specified in this manual may result in hazardous radiation exposure.



Although this gateway has been tested up to 1 kV per CE immunity requirements, it requires surge protection to be provided as part of the building installation to protect against unidirectional surges resulting from electrical switching and lightning strikes.

For protection against these surges in an outdoor installation, any exposed wiring must be shielded, and the shield for the wiring must be grounded at both ends.

Wireless Channel Restrictions

Table 7 *Frequency Range Table*

Frequency Range MHz	Max EIRP
2402-2480	-8 dbm

Battery Statements



Il y a danger d'explosion s'il y a remplacement incorrect de la batterie.
Remplacer uniquement avec une batterie due même type ou d'un équivalent recommandé par le constructeur.
Mettre au rebut les batteries usagées conformément aux unstruction du fabricant.



The battery supplied with this product may contain perchlorate material. Special handling may apply in California and certain other states. See www.dtsc.ca.gov/hazardouswaste/perchlorate for more information.



There is a risk of explosion if battery is replaced by an incorrect type, so dispose used batteries according to the instructions.

Japan VCCI

This product is a Class B product based on the standard of the VCCI Council. If this is used near a radio or television receiver in a domestic environment, it may cause radio interference. Install and use the equipment according to the instruction manual.

Regulatory Model Name

The regulatory model name for the Aruba 9004 Gateway is ARCN9004.

Proper Disposal of Aruba Equipment

Waste of Electrical and Electronic Equipment



Aruba Networks, a Hewlett Packard Enterprise company products at end of life are subject to separate collection and treatment in the EU Member States, Norway, and Switzerland and therefore are marked with the symbol shown at the left (crossed-out wheelie bin). The treatment applied at end of life of these products in these countries shall comply with the applicable national laws of countries implementing Directive 2012/19/EU on Waste of Electrical and Electronic Equipment (WEEE).

European Union RoHS



Aruba Networks, a Hewlett Packard Enterprise company products also comply with the EU Restriction of Hazardous Substances Directive 2011/65/EU (RoHS). EU RoHS restricts the use of specific hazardous materials in the manufacture of electrical and electronic equipment. Specifically, restricted materials under the RoHS Directive are Lead (including Solder used in printed circuit assemblies), Cadmium, Mercury, Hexavalent Chromium, and Bromine. Some Aruba products are subject to the exemptions listed in RoHS Directive Annex 7 (Lead in solder used in printed circuit assemblies). Products and packaging will be marked with the “RoHS” label shown at the left indicating conformance to this Directive.

India RoHS

This product complies with RoHS requirements as prescribed by E-Waste (Management & Handling) Rules, governed by the Ministry of Environment & Forests, Government of India.

China RoHS



Aruba Networks, a Hewlett Packard Enterprise company products also comply with China environmental declaration requirements and are labeled with the “EFUP 10” label shown at the left.

有毒有害物质声明 Hazardous Materials Declaration

部件名称 (Parts)	有毒有害物质或元素 (Hazardous Substance)					
	铅 (Pb)	汞 (Hg)	镉 (Cd)	六价铬 (Cr ⁶⁺)	多溴联苯 (PBB)	多溴二苯醚 (PBDE)
电路板 (PCA Boards)	×	○	○	○	○	○
机械组件 (Mechanical Sub-Assemblies)	×	○	○	○	○	○
<p>○：表示该有毒有害物质在该部件所有均质材料中的含量均在 SJ/T11363-2006 标准规定的限量要求以下。 Indicates that the concentration of the hazardous substance in all homogeneous materials in the parts is below the relevant threshold of the SJ/T11363-2006 standard.</p> <p>×：表示该有毒有害物质至少在该部件的某一均质材料中的含量超出SJ/T11363-2006标准规定的限量要求。 Indicates that the concentration of the hazardous substance of at least one of all homogeneous materials in the parts is above the relevant threshold of the SJ/T11363-2006 standard.</p> <p>对销售之日的所售产品, 本表显示, 供应链的电子息产品可能包含这些物质。 This table shows where these substances may be found in the supply chain of electronic information products, as of the date of sale of the enclosed product.</p>						
<p>此标志为针对所涉及产品的环保使用期标志。某些零部件会有一个不同的环保使用期 (例如, 电池单元模块) 贴在其产品上。 此环保使用期限只适用于产品是在产品手册中所规定的条件下工作。 The Environment- Friendly Use Period (EFUP) for all enclosed products and their parts are per the symbol shown here. The Environment- Friendly Use Period is valid only when the product is operated under the conditions defined in the product manual.</p>						

Korean

B급 기기 (가정용 방송통신기기)	이 기기는 가정용(B급)으로 전자파적합등록을 한 기기로서 주로 가정에서 사용하는 것을 목적으로 하며, 모든 지역에서 사용할 수 있습니다.
-----------------------	--

Taiwan

所有技術文件皆必須秀出廠牌 / 型號，而使用手冊必須再補上警語，其警語內容如下：依據低功電波射性電機管辦法第十二條

※ 經型式認證合格之低功射頻電機，非經許可，公司、商號或使用者均不得擅自變頻、加大功或變原設計之特性及功能。

第十四條

※ 低功射頻電機之使用不得影響飛航安全及干擾合法通信；經發現有干擾現象時，應即停用，並改善至無干擾時方得繼續使用。

- 前項合法通信，指依電信法規定作業之無線電通信。

- 低功射頻電機須忍受合法通信或工業、科學及醫療用電波射性電機設備之干擾。

支援 5G 功能則必須補上 “應避免影響附近雷達系統之操作”

不具備外接或替換天線時須加註：“高增益指向性天線只得應用於固定式點對點系統。

第十二條 經型式認證合格之低功率射頻電機，非經許可，公司、商號或使用者均不得擅自變更頻率、加大功率或變更原設計之特性及功能。

第十四條 低功率射頻電機之使用不得影響飛航安全及干擾合法通信；經發現有干擾現象時，應立即停用，並改善至無干擾時方得繼續使用。

前項合法通信，指依電信法規定作業之無線電通信。

低功率射頻電機須忍受合法通信或工業、科學及醫療用電波輻射性電機設備之干擾。

1. 應避免影響附近雷達系統之操作。
2. 高增益指向性天線只得應用於固定式點對點系統
3. 電磁波暴露量 MPE 標準值 1 mW/cm², 送測產品實測值為：0.46mW/cm²

Нормативные требования Евразийского Экономического Союза

Russia



'НРЕ Russia': ООО "Хьюлетт Паккард Энтерпрайз" Российская Федерация, 125171, г. Москва, Ленинградское шоссе, 16А, стр.3, Телефон: +7 499 403 4248 Факс: +7 499 403 4677

'НРЕ Belarus': ИООО «Хьюлетт-Паккард Бел», Республика Беларусь, 220030, г. Минск, ул. Интернациональная, 36-1, Телефон/факс: +375 17 392 28 20

'НРЕ Kazakhstan': ТОО «Хьюлетт-Паккард (К)», Республика Казахстан, 050040, г. Алматы, Бостандыкский район, проспект Аль-Фараби, 77/7, Телефон/факс: +7 727 355 35 50

Kazakhstan

ЖШС "Хьюлетт Паккард Энтерпрайз" Ресей Федерациясы, 125171, Мәскеу, Ленинград тас жолы, 16А блок 3, Телефон: +7 499 403 4248 Факс: +7 499 403 4677

«HEWLETT-PACKARD Bel» ЖШС, Беларусь Республикасы, 220030, Минск қ., Интернациональная көшесі, 36/1, Телефон/факс: +375 17 392 28 20

ЖШС «Хьюлетт-Паккард (К)», Қазақстан Республикасы, 050040, Алматы қ., Бостандық ауданы, Әл-Фараби даңғылы, 77/7, Телефон/факс: +7 (727) 355 35 50

Mexico

La operación de este equipo está sujeta a las siguientes dos condiciones: (1) es posible que este equipo o dispositivo no cause interferencia perjudicial y (2) este equipo o dispositivo debe aceptar cualquier interferencia,

incluyendo la que pueda causar su operación no deseada.