

605R Series Remote Access Points

Installation Guide

The Aruba 605R Series access points are dual-radio tri-band 802.11ax Wi-Fi 6E remote access points that provide connectivity for both wired and wireless client devices.

Package Contents

The following materials are included with this product:

- AP-605R Access Point x 1
- AC-to-DC Power Adapter (with power cord) x 1
- (For AP-605R bundle only) Aruba AP-605CM12 LTE CAT12 Cellular Module (pre-installed) x 1



To simplify the ordering, Aruba offers the AP-605R bundle that combines an AP-605R access point, a power adapter (with power cord) and a AP-605CM12 LTE CAT12 Cellular Module (pre-installed)

Hardware Overview

Figure 1 AP-605R Front View

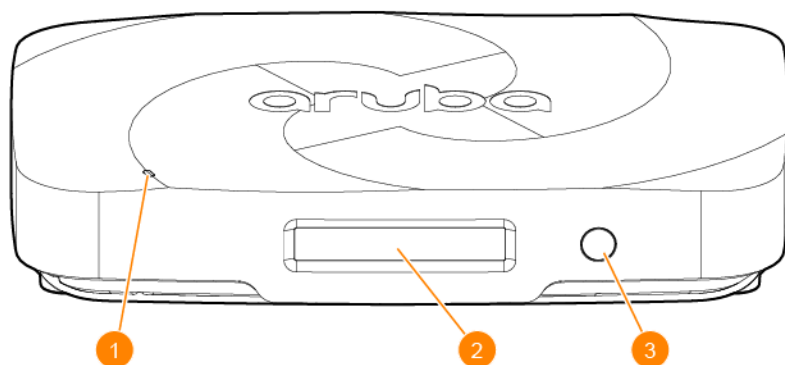

1	System Status LED
2	LCD Panel
3	LCD Button

Figure 2 AP-605R Bundle Front View

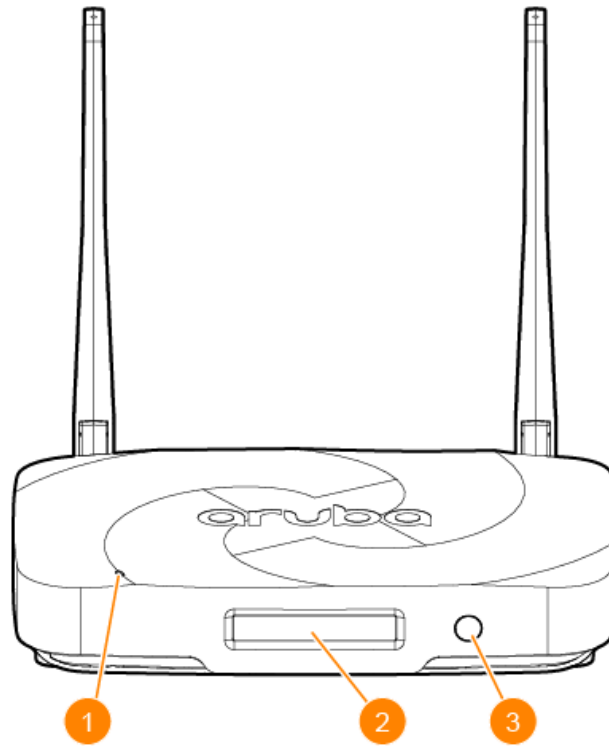

1	System Status LED
2	LCD Panel
3	LCD Button



The antennas of the LTE module are in a folded position when taken out of the package. To ensure the antennas function well, put the antennas in a vertical position as shown in .

System Status LED

The system status LED is located on the top panel of the access point indicates the system status of the access point.

Table 1: System Status LED

Color/State	Meaning
Off	Access point powered off
Green - blinking ¹	Access point booting, not ready
Green - solid	Access point ready, fully functional
Red	System error condition or thermal shutdown engaged - Immediate attention required

1. Blinking: one second on, one second off, 2 seconds cycle.

LED Display Settings

The LEDs have three operating modes that can be selected in the system management software:

- Normal mode: default after power on. Refer to [Table 1](#).
- Off mode: the LED is off
- Blink mode: the LED blinks green

Pressing the reset button for less than 10 seconds during normal operation will toggle the LED mode between "normal" (default after power on) and "off" mode.



Pressing the reset button for longer than 10 seconds may cause the access point to reset and return to the factory default state.

LCD Panel

The LCD panel is located on the front panel of the access point that displays the access point's bootup and system status information.

The LCD button is located on the right side of the LCD panel and used to operate the LCD panel:

- When booted up, the LCD will display the home page, which is Aruba logo by default, but it is configurable by the system management software. Short pressing the LCD button will scroll through the pages on the LCD screen. The LCD display will return to the home page after 10 seconds of inactivity.
- Long pressing the LCD button will adjust the LCD's backlight brightness.

Table 2: *LCD Panel Displays*

Access Point State	LCD Displays
During access point boot (system status LED blinking green)	Display bootup status information, such as "AP powering up...", "Connecting to network" and etc.
Access point is up and running (system status LED solid green)	Display logo (home page) and system status information. Short pressing the LCD button on the right of the LCD screen will scroll through pages.
Access point is in error condition or thermal shutdown mode (system status LED solid red)	Display relevant information about the error condition.

Figure 3 605R Series Rear and Side View

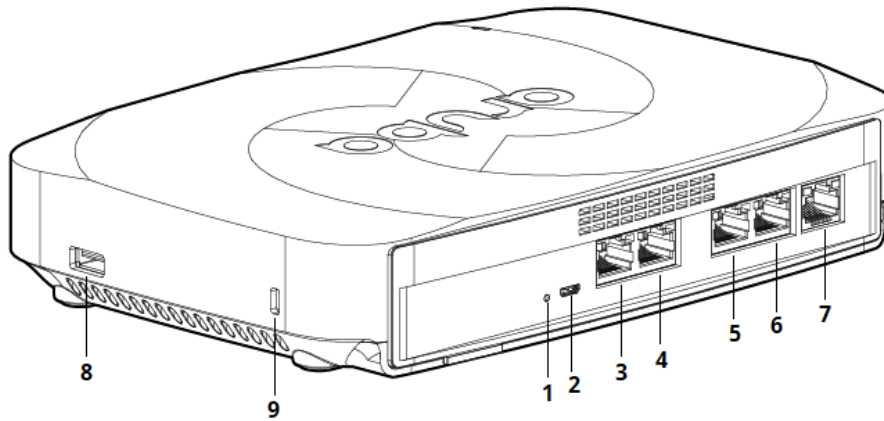

1	Reset Button
2	Micro-B Console Port
3	E0 Ethernet Port (Orange)
4	E1 Ethernet Port (Orange and Blue)
5	E2 Ethernet Port (Blue)
6	E3 Ethernet Port (Blue)
7	E4 Ethernet Port (Red)
8	USB Interface
9	Kensington Lock Slot

Reset Button

The reset button can be used to reset the access point to factory default settings or turn off/on the LED display.

Use one of the following methods to reset the access point to factory default settings:

- To reset during normal operation:
 - Hold the reset button for more than 10 seconds while the access point is running.
 - Release the reset button.
- To reset during power up, hold the reset button while the access point is powering up.

The system status LED will flash again within 15 seconds indicating that the reset is completed. The access point will now continue to boot with the factory default settings.

To toggle the system status LED between “normal” (default after power on) and “off” mode, during the normal operation of the access point, shortly press the reset button for less than 10 seconds.

Micro-B Console Port

To create a console connection to the access point, follow these steps:

1. Connect the console port on the access point to the serial port on the computer using the proprietary Aruba AP-CBL-SERU cable or AP-MOD-SERU module, which need to be purchased separately.
2. Start the terminal emulation software on the computer and configure a new serial session with the following settings:
 - Speed: 9600 bps
 - Data bits: 8
 - Stop bits: 1
 - Parity: None
 - Flow control: None
3. Start the terminal emulation session.
4. Press **Enter** once. If the connection is successful, you are prompted to login.

For this console port pin-out details, refer to [Figure 4](#).

Figure 4 *Micro-B Console Port Pin-out*

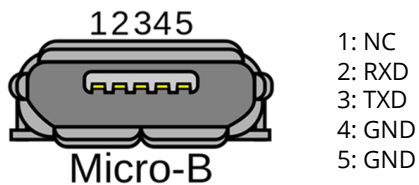

If needed, the AP console driver can be found at the [Aruba support portal](#).

Ethernet Ports

The 605R Series access point has five Ethernet ports (E0 - E4), shown in [Figure 3](#).

- The E0 port is a 100/1000Base-T auto-sensing MDI/MDIX uplink port .
- The E1 port is a 100/1000/2500Base-T auto-sensing MDI/MDIX port, which can be configured as a secondary uplink port or downlink port by system management software.
- The E2- E4 ports are 100/1000Base-T auto-sensing MDI/MDIX downlink ports. E4 port is the PoE out port and capable to supply PoE power to a 802.3af-compliant device that is physically connected to the E4 port by Ethernet cable.

Ethernet Port LEDs

Each of the E0-E3 ports has one LED located on the left side, indicating the network status or activity on the port.

The E4 port has two LEDs located on both sides, the left LED indicating the network status or activity on the port, while the right LED indicating the PoE powering status when the access point is operating as a Power Sourcing Equipment (PSE). See [Figure 3](#) and [Table 3](#)

Table 3: Ethernet Port LEDs

LED	Color/State	Meaning
Left	Off	Meet one of the following conditions: <ul style="list-style-type: none">■ access point is powered off■ port is disabled■ no link established
	Green - blinking	Activity detected on the port
	Green - solid	Link established at optimum speed (1Gbps or 2.5Gbps)
	Amber - solid	Link established at reduced speed (100Mbps)
Right (E4 only)	Off	Meet one of the following conditions: <ul style="list-style-type: none">■ access point is powered off■ access point is not supplying PoE power
	Green - blinking	Access point is negotiating PoE power with the device connected to this port.
	Green - solid	Access point is supplying PoE power to the device connected to this port.

USB interface

The USB 2.0 USB-A interface is compatible with selected cellular modems and other peripherals. When active, this USB interface can supply up to 5W/1A to a connected device.

Kensington Lock Slot

The AP-605R access point is equipped with a Kensington lock slot for additional physical security.

DC Power Port

The DC power port is designed for use with the Aruba AP-AC2-48C power adapter (included in the package).

After inserting the L-shape DC connector into the DC power port, users can rotate the DC connector by 90 degrees and route the power cord to the left of the DC power port. See [Figure 5](#) and [Figure 6](#).

Figure 5 Connecting Power Adapter to DC Power Port

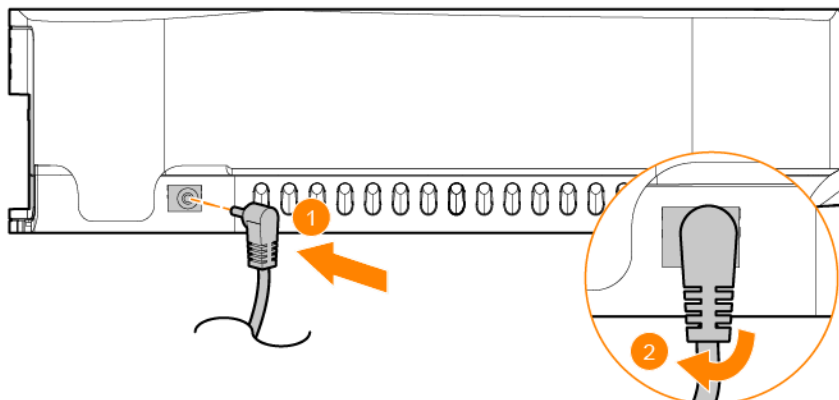
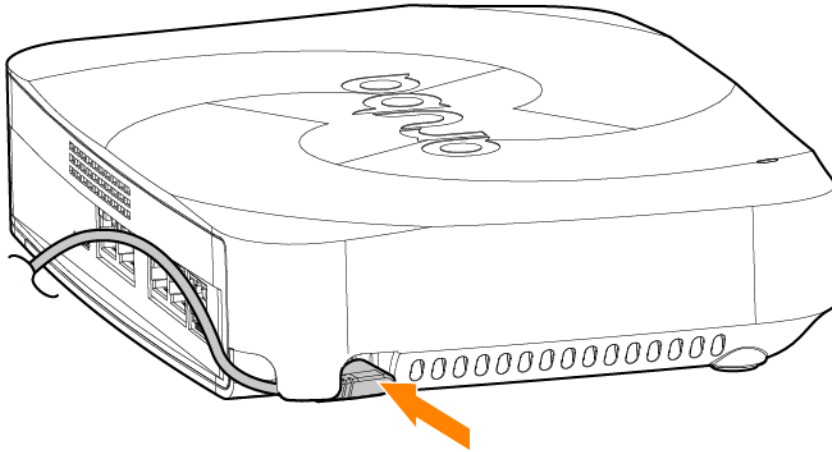

Figure 6 Routing Power Cord



Access Point Installation



All Aruba access points should be professionally installed by a professional installer. The installer is responsible for meeting applicable national and electrical codes. Failure to properly install this product may result in physical injury and/or damage to property.



Tous les points d'accès Aruba doivent impérativement être installés par un professionnel agréé. Ce dernier doit s'assurer que l'appareil est mis à la terre et que le circuit de mise à la terre est conforme aux codes électriques nationaux en vigueur. Le fait de ne pas installer correctement ce produit peut entraîner des blessures corporelles et / ou des dommages matériels.



For indoor use only. The access point, power adapter, and all connected cables are not to be installed outdoors. This stationary device is intended for stationary use in partly temperature controlled weather-protected environments (class 3.2 per ETSI 300 019).

You can put the 605R Series access point on any flat surface such as a desktop.

Installing the SIM Card (For AP-605R Bundle Only)

To use the AP-605CM12 cellular module, you need to install a SIM card to the SIM card tray on the AP-605CM12 cellular module. The SIM card tray has two SIM card slots - SIM slot 1 and SIM slot 2. At any given time, only one SIM card is active and functional, the SIM slot 1 and SIM slot 2 can not be used simultaneously. If you have only one SIM card, it is recommended to insert your SIM card to the SIM slot 1.

To install a SIM card into the SIM tray, perform the following steps:

1. Remove the AP-605CM12 cellular module from the AP-605R access point.
 - a. Unfasten the two M3 captive screws using a Phillips screwdriver
 - b. Press the mounting tab on the cellular module, and pull the cellular module out. See [Figure 7](#).

Figure 7 Removing Cellular Module from the Access Point

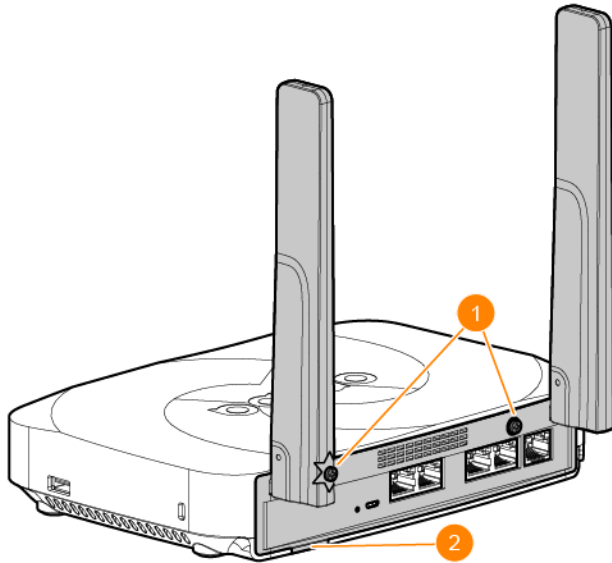

1	Captive screws
2	Mounting tab

2. Insert the SIM ejector needle (provided in package) into the small hole on the SIM card tray. The SIM card tray will pop open. See [Figure 8](#).

Figure 8 Opening the SIM Card Tray

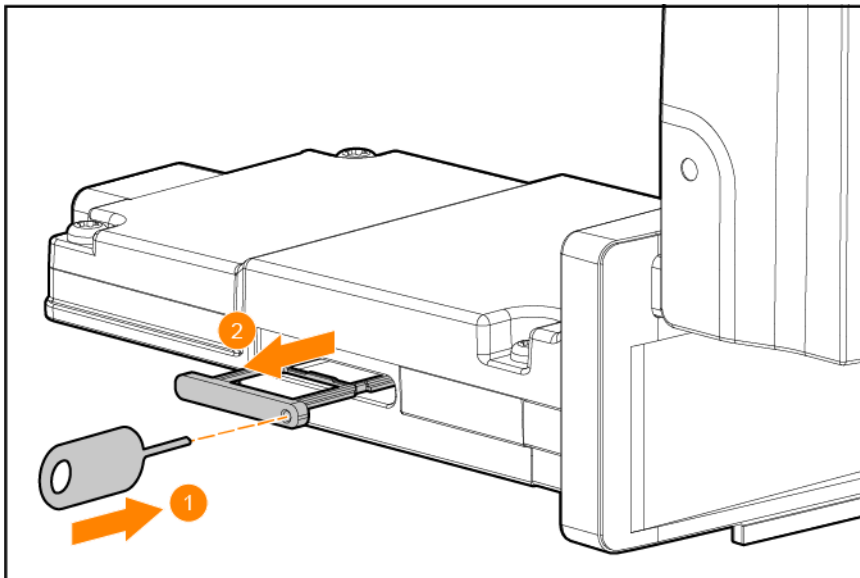

3. Pull out the SIM card tray and insert a SIM card into the SIM tray.
4. Push the SIM card tray back into the slot. See [Figure 9](#).

Figure 9 Inserting a SIM Card

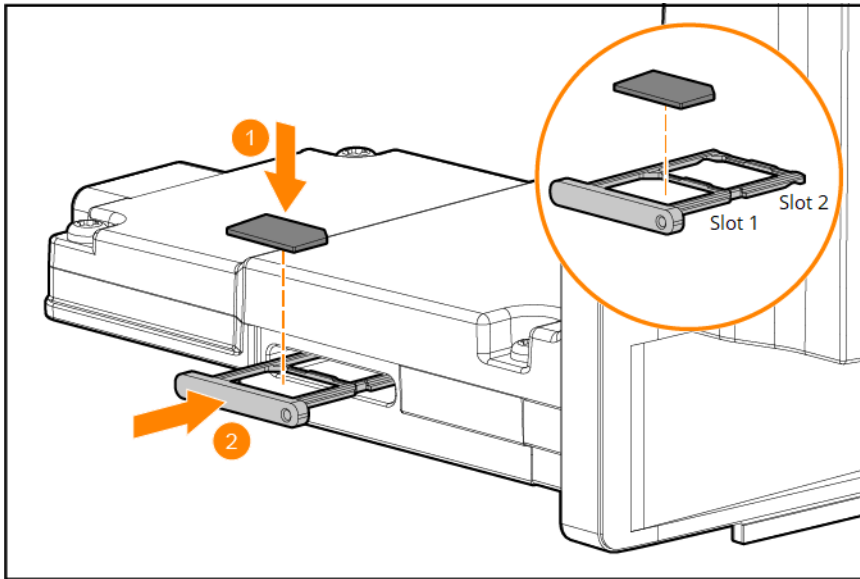

5. Align the AP-605CM12 cellular module with the opening in the access point.
6. Insert the AP-605CM12 cellular module into the access point and tighten the two M3 captive screws using a Phillips screwdriver. See [Figure 10](#).

Figure 10 Installing Cellular Module onto Access Point

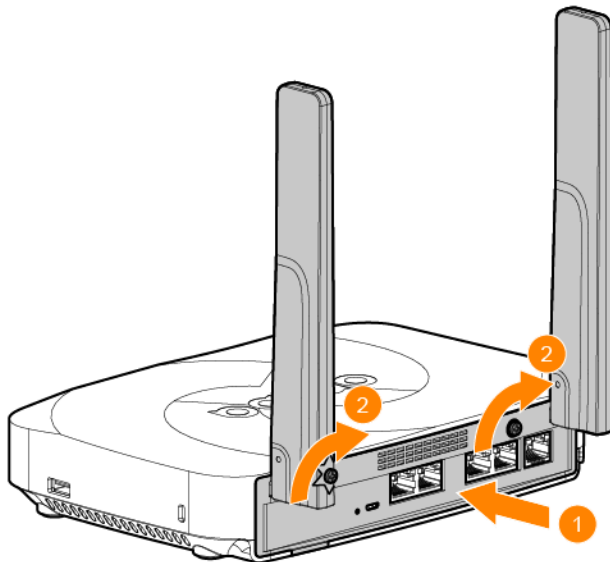

Software

For instructions on choosing operating modes and initial software configuration, refer to the [AP Software Quick Start Guide](#).



Aruba access points are classified as radio transmission devices, and are subject to government regulations of the host country. The network administrator(s) is/are responsible for ensuring that configuration and operation of this equipment is in compliance with their country's regulations. For a complete list of approved channels in your country, refer to the Aruba Downloadable Regulatory Table at <https://www.arubanetworks.com/techdocs/DRT/content/home.htm>.

Verifying Post-Installation Connectivity

The integrated LEDs on the access point can be used to verify that the access point is receiving power and initializing successfully. See [Table 1](#), [Table 1](#) and [Table 3](#).

- Ethernet:
 - E0 port: 100/1000Base-T auto-sensing MDI/MDX wired RJ45 network connectivity port
 - E1 port: 100/1000/2500Base-T auto-sensing MDI/MDX wired RJ45 network connectivity port
 - E2 port: 100/1000Base-T auto-sensing MDI/MDX wired RJ45 network connectivity port
 - E3 port: 100/1000Base-T auto-sensing MDI/MDX wired RJ45 network connectivity port
 - E4 port: 100/1000Base-T auto-sensing MDI/MDX wired RJ45 network connectivity port, supporting PoE-PSE to a 802.3af-compliant device.
- Power
 - 48V DC power interface, support powering through AC-to-DC power adapter
 - Maximum power consumption: Refer to datasheet

Environmental

- Operating
 - Temperature: 0°C to +40°C (+32°F to +104°F)
 - Humidity: 5% to 95% non-condensing
- Storage
 - Temperature: -25°C to 55°C (-13°F to 131°F)
 - Humidity: 10% to 100% non-condensing

Regulatory Information

For the purpose of regulatory compliance certifications and identification, this product has been assigned a unique regulatory model number (RMN). The regulatory model number can be found on the product nameplate label, along with all required approval markings and information. When requesting compliance information for this product, always refer to this regulatory model number. The regulatory model number RMN is not the marketing name or model number of the product.

The following regulatory model numbers apply to the 605R Series

- AP-605R RMN: APINR605
- AP-605CM12 RMN: APINCM12

Changes or modifications not expressly approved by the party responsible for compliance could void the user's authority to operate this equipment.

Toute modification effectuée sur cet équipement sans l'autorisation expresse de la partie responsable de la conformité est susceptible d'annuler son droit d'utilisation.



Safety and Regulatory Compliance

FCC Statement: Improper termination of access points installed in the United States configured to non-US model controllers will be in violation of the FCC grant of equipment authorization. Any such willful or intentional violation may result in a requirement by the FCC for immediate termination of operation and may be subject to forfeiture (47 CFR 1.80).





RF Radiation Exposure Statement: This equipment complies with RF radiation exposure limits. This equipment should be installed and operated with a minimum distance of 7.87 inches (20 cm) between the radiator and your body for 2.4 GHz, 5 GHz, and 6GHz operations. This transmitter must not be co-located or operating in conjunction with any other antenna or transmitter.



Déclaration e la concernant l'exposition aux rayonnements à fréquence radioélectrique: Cet appareil est conforme aux limites d'exposition aux rayonnements FR établies par la FCC. Il doit être installé et utilisé à une distance minimale de 20 cm (7.87 pouces) entre le radiateur et votre corps, qu'il opère sur la bande 2,4 GHz, 5 GHz, ou 6GHz. Cet émetteur ne doit pas être installé ou utilisé à proximité immédiate d'une autre antenne ni d'un autre transmetteur.



The device could automatically discontinue transmission in case of absence of information to transmit, or operational failure. Note that this is not intended to prohibit transmission of control or signaling information or the use of repetitive codes where required by the technology.

Brazil

Este equipamento não tem direito à proteção contra interferência prejudicial e não pode causar interferência em sistemas devidamente autorizados.

O uso deste equipamento é restrito a ambientes fechados e proibido em plataformas petrolíferas, carros, trens, embarcações e no interior de aeronaves abaixo de 3.048 m (10.000 pés).

Canada

This Class B digital apparatus meets all of the requirements of the Canadian Interference-Causing Equipment Regulations.

This device contains licence-exempt transmitter(s)/receiver(s) that comply with Innovation, Science and Economic Development Canada's licence-exempt RSS(s). Operation is subject to the following two conditions: (1) This device may not cause interference; and (2) This device must accept any interference, including interference that may cause undesired operation of the device.

When operated in 5.15 to 5.25 GHz frequency range, this device is restricted to indoor use to reduce the potential for harmful interference with co-channel Mobile Satellite Systems.

- a). Operation shall be limited to indoor use only;
- (b). Operation on oil platforms, cars, trains, boats and aircraft shall be prohibited except for on large aircraft flying above 10,000 ft.

Canada

Cet appareil numérique de classe B respecte toutes les exigences du Règlement sur le matériel brouilleur du Canada.

Cet appareil contient des émetteurs / récepteurs exemptés de licence qui sont conformes aux RSS exempts de licence d'Innovation, Sciences et Développement économique Canada. Son fonctionnement est soumis aux deux conditions suivantes: (1) ce périphérique ne doit pas provoquer d'interférences, et (2) ce périphérique doit accepter toute interférence, y compris les interférences susceptibles de provoquer un dysfonctionnement.

En cas d'utilisation dans la plage de fréquences de 5,15 à 5,25 GHz, cet appareil doit uniquement être utilisé à l'intérieur afin de réduire les risques d'interférence avec les systèmes satellites mobiles partageant le même canal.

- (1) Le fonctionnement doit être limité à une utilisation en intérieur uniquement ;

(2) L'exploitation sur les plates-formes pétrolières, les voitures, les trains, les bateaux et les aéronefs est interdite, sauf pour les gros aéronefs volant au-dessus de 10 000 pieds.

EU and UK Regulatory Conformity

The Declaration of Conformity made under Radio Equipment Directive 2014/53/EU as well as the United Kingdom's Radio Equipment Regulations 2017/UK is available for viewing below. Select the document that corresponds to your device's model number as it is indicated on the product label.

- [EU & UK Declaration of Conformity](#)

Compliance is only assured if the Aruba approved accessories as listed in the ordering guide are used.

https://www.arubanetworks.com/assets/og/OG_605RSeries.pdf.

Wireless Channel Restrictions

5150-5350MHz band is limited to indoor only in the following countries; Austria (AT), Belgium (BE), Bulgaria (BG), Croatia (HR), Cyprus (CY), Czech Republic (CZ), Denmark (DK), Estonia (EE), Finland (FI), France (FR), Germany (DE), Greece (GR), Hungary (HU), Iceland (IS), Ireland (IE), Italy (IT), Latvia (LV), Liechtenstein (LI), Lithuania (LT), Luxembourg (LU), Malta (MT), Netherlands (NL), Norway (NO), Poland (PL), Portugal (PT), Romania (RO), Slovakia (SK), Slovenia (SL), Spain (ES), Sweden (SE), Switzerland (CH), Turkey (TR), United Kingdom (UK (NI)).

Radio	Frequency Range MHz	Max EIRP
BLE/Zigbee	2402-2480	9 dBm
Wi-Fi	2412-2472	20 dBm
	5150-5250	23 dBm
	5250-5350	23 dBm
	5470-5725	30 dBm
	5725-5850	14 dBm
	5945-6425	23 dBm



Lower power radio LAN product operating in 2.4 GHz and 5 GHz bands. Please refer to the ArubaOS User Guide/Instant User Guide for details on restrictions.

European Union and United Kingdom

This device is limited for indoor use. Use in trains with metal-coated windows (or similar structures made of materials with comparable attenuation characteristic) and aircraft is permitted. Operations in the 6GHz band are blocked by firmware for some countries pending adoption of spectrum. Refer to Aruba DRT release notes for details.

Japan

ご使用になっている装置に VCCI マークが付いていましたら、次の説明文をお読み下さい。

この装置は、クラス B 情報技術装置です。この装置は、家庭環境で使用することを目的としていますが、この装置がラジオやテレビジョン受信機に近接して使用されると、受信障害を引き起こすことがあります。取扱説明書に従って正しい取り扱いをして下さい。

VCCI-B

Korean

8급 기기 (가정용 방송통신기기)	이 기기는 가정용(B급)으로 전자파적합성을 한 기기로서 주로 가정에서 사용하는 것을 목적으로 하며, 모든 지역에서 사용할 수 있습니다.
-----------------------	---

México

La operación de este equipo está sujeta a las siguientes dos condiciones: (1) es posible que este equipo o dispositivo no cause interferencia perjudicial y (2) este equipo o dispositivo debe aceptar cualquier interferencia, incluyendo la que pueda causar su operación no deseada.

Нормативные требования Евразийского Экономического Союза

Russia



НРЕ Russia: ООО "Хьюлетт Паккард Энтерпрайз" Российская Федерация, 125171, г. Москва, Ленинградское шоссе, 16А, стр.3, Телефон: +7 499 403 4248 Факс: +7 499 403 4677

'НРЕ Kazakhstan': ТОО «Хьюлетт-Паккард (К)», Республика Казахстан, 050040, г. Алматы, Бостандыкский район, проспект Аль-Фараби, 77/7, Телефон/факс: +7 727 355 35 50

Kazakhstan

ЖШС "Хьюлетт Паккард Энтерпрайз" Ресей Федерациясы, 125171, Мәскеу, Ленинград тас жолы, 16А блок 3, Телефон: +7 499 403 4248 Факс: +7 499 403 4677

ЖШС «Хьюлетт-Паккард (К)», Қазақстан Республикасы, 050040, Алматы қ., Бостандық ауданы, Әл-Фараби даңғылы, 77/7, Телефон/факс: +7 (727) 355 35 50

Ukraine

Hereby, Hewlett Packard Enterprise Company declares that the radio equipment type [The Regulatory Model Number [RMN] for this device can be found in the [Regulatory Information](#) section of this document] is in compliance with Ukrainian Technical Regulation on Radio Equipment, approved by resolution of the CABINET OF MINISTERS OF UKRAINE dated May 24, 2017, No. 355. The full text of the UA declaration of conformity is available at the following internet address:

<https://certificates.ext.hpe.com/public/certificates.html>.

Х'ЮЛЕТТ ПАКАРД ЕНТЕРПРАЗ, 6280 АМЕРИКА ЦЕНТР Д-Р, САН-ХОСЕ, КАЛИФОРНИЯ 95002, США

Taiwan

第十二條

經型式認證合格之低功率射頻電機，非經許可，公司，商號或使用者均不得擅自變更頻率、加大功率或變更原設計之特性及功能。

第十四條

低功率射頻電機之使用不得影響飛航安全及干擾合法通信；經發現有干擾現象時，應立即停用，並改善至無干擾時方得繼續使用。

前項合法通信，指依電信法規定作業之無線電通信。低功率射頻電機須忍受合法通信或工業、科學及醫療用電波輻射性電機設備之干擾。

1. 應避免影響附近雷達系統之操作。
2. 高增益指向性天線只得應用於固定式點對點系統
3. 電磁波暴露量 MPE 標準值 1 mW/cm^2 , 送測產品實測值為： 0.0829 mW/cm^2 (沒有LTE模組) 或 0.0997 mW/cm^2 (安裝LTE模組)

UKCA



EU & UK Regulatory Contact:

HPE, Postfach 0001, 1122 Wien, Austria

United States

This device complies with Part 15 of the FCC Rules. Operation is subject to the following two conditions: (1) this device may not cause harmful interference, and (2) this device must accept any interference received, including interference that may cause undesired operation.

This equipment has been tested and found to comply with the limits for a Class B digital device, pursuant to Part 15 of the FCC Rules. These limits are designed to provide reasonable protection against harmful interference in a residential installation. This equipment generates, uses and can radiate radio frequency energy and, if not installed and used in accordance with the manufacturer's instructions, may cause harmful interference to radio communications. However, there is no guarantee that interference will not occur in a particular installation. If this equipment does cause harmful interference to radio or television reception, which can be determined by turning the equipment off and on, the user is encouraged to try to correct the interference by one or more of the following measures

- Reorient or relocate the receiving antenna.
- Increase the separation between the equipment and receiver.
- Connect the equipment to an outlet on a circuit different from that to which the receiver is connected.
- Consult the dealer or an experienced radio or TV technician for help.

Improper termination of access points installed in the United States configured to a non-US model controller is a violation of the FCC grant of equipment authorization. Any such willful or intentional violation may result in a requirement by the FCC for immediate termination of operation and may be subject to forfeiture (47 CFR 1.80).

The network administrator(s) is/are responsible for ensuring that this device operates in accordance with local/regional laws of the host domain.



FCC regulations restrict the operation of this device to indoor use only.

The operation of this device is prohibited on oil platforms, cars, trains, boats, and aircraft, except that operation of this device is permitted in large aircraft while flying above 10,000 feet.

Operation in the 5.9725-7.125GHz band is prohibited for control of or communication with unnamed aircraft systems.

Medical

1. Equipment not suitable for use in the presence of flammable mixtures.
2. Connect to only IEC 60950-1 or IEC 60601-1 certified products and power sources. The end user is responsible for the resulting medical system complies with the requirements of IEC 60601-1.
3. Wipe with a dry cloth, no additional maintenance required.
4. No serviceable parts, the unit must be sent back to the manufacturer for repair.
5. No modifications are allowed without Aruba approval.

Contacting Support

Table 4: *Contact Information*

Main Site	https://www.arubanetworks.com
Support Site	https://asp.arubanetworks.com
Airheads Social Forums and Knowledge Base	https://community.arubanetworks.com
North American Telephone	1-800-943-4526 (Toll Free) 1-408-754-1200
International Telephone	https://arubanetworks.com/support-services/contact-support/
Software Licensing Site	https://hpe.com/networking/support
End-of-life Information	https://www.arubanetworks.com/support-services/end-of-life/
Security Incident Response Team	https://www.arubanetworks.com/support-services/security-bulletins/ Email: aruba-sirt@hpe.com

Copyright Information

© Copyright 2023 Hewlett Packard Enterprise Development LP.

This product includes code licensed under certain open source licenses which require source compliance. The corresponding source for these components is available upon request. This offer is valid to anyone in receipt of this information and shall expire three years following the date of the final distribution of this product version by Hewlett Packard Enterprise Company. To obtain such source code, please check if the code is available in the HPE Software Center at <https://myenterpriselicense.hpe.com/cwp-ui/software> but,

if not, send a written request for specific software version and product for which you want the open source code. Along with the request, please send a check or money order in the amount of US \$10.00 to:

Hewlett Packard Enterprise Company
Attn: General Counsel
WW Corporate Headquarters
1701 E Mossy Oaks Rd Spring, TX 77389
United States of America.