



RF MEASUREMENT REPORT

FCC ID: Q9DAPINR605
Applicant: Hewlett Packard Enterprise Company
Product: ACCESS POINT
Model No.: APINR605
Trademark:  
FCC Classification: Digital Transmission System (DTS)
FCC Rule Part(s): Part 15 Subpart C (Section 15.247)
Result: Complies
Received Date: 2022-09-30
Test Date: 2022-10-18 ~ 2023-03-22

Reviewed By:

Jame Yuan

Approved By:

Robin Wu



The test results relate only to the samples tested.

This equipment has been shown to be capable of compliance with the applicable technical standards as indicated in the measurement report and was tested in accordance with the measurement procedures specified in ANSI C63.10-2013. Test results reported herein relate only to the item(s) tested.

The test report shall not be reproduced except in full without the written approval of MRT Technology (Suzhou) Co., Ltd.

Revision History

Report No.	Version	Description	Issue Date	Note
2209RSU069-U3	Rev. 01	Initial Report	2023-03-23	Valid

CONTENTS

Description	Page
1. General Information	5
1.1. Applicant	5
1.2. Manufacturer	5
1.3. Testing Facility	5
1.4. Product Information.....	6
1.5. Radio Specification under Test	7
1.6. Working Frequencies	7
1.7. Antenna Details.....	8
1.8. Description of EUT Filter.....	9
2. Test Configuration	10
2.1. Test Mode.....	10
2.2. Test System Connection Diagram.....	11
2.3. Test Software	11
2.4. Applied Standards.....	11
2.5. Test Environment Condition	12
3. Antenna Requirements	13
4. Measuring Instrument	14
5. Decision Rules and Measurement Uncertainty	15
5.1. Decision Rules	15
5.2. Measurement Uncertainty.....	15
6. Test Result.....	16
6.1. Summary.....	16
6.2. 6dB Bandwidth Measurement.....	17
6.2.1. Test Limit	17
6.2.2. Test Procedure	17
6.2.3. Test Setting	17
6.2.4. Test Setup	17
6.2.5. Test Result	17
6.3. Output Power Measurement	18
6.3.1. Test Limit	18
6.3.2. Test Procedure	18
6.3.3. Test Setting	18
6.3.4. Test Setup	18
6.3.5. Test Result	18
6.4. Power Spectral Density Measurement	19

6.4.1.	Test Limit	19
6.4.2.	Test Procedure	19
6.4.3.	Test Setting	19
6.4.4.	Test Setup	19
6.4.5.	Test Result	20
6.5.	Conducted Band Edge and Out-of-Band Emissions Measurement	21
6.5.1.	Test Limit	21
6.5.2.	Test Procedure	21
6.5.3.	Test Settintg	21
6.5.4.	Test Setup	21
6.5.5.	Test Result	22
6.6.	Radiated Spurious Emission Measurement.....	23
6.6.1.	Test Limit	23
6.6.2.	Test Procedure	23
6.6.3.	Test Setting	23
6.6.4.	Test Setup	25
6.6.5.	Test Result	26
6.7.	Radiated Restricted Band Edge Measurement	27
6.7.1.	Test Limit	27
6.7.2.	Test Procedure	28
6.7.3.	Test Setting	28
6.7.4.	Test Setup	30
6.7.5.	Test Result	30
6.8.	AC Conducted Emissions Measurement	31
6.8.1.	Test Limit	31
6.8.2.	Test Setup	31
6.8.3.	Test Result	31
Appendix A – Test Result		32
A.1	Duty Cycle Test Result	32
A.2	6dB Bandwidth Test Result	36
A.3	Output Power Test Result	50
A.4	Power Spectral Density Test Result.....	56
A.5	Conducted Band Edge and Out-of-Band Emissions Test Result.....	82
A.6	Radiated Spurious Emission Test Result.....	176
A.7	Radiated Restricted Band Edge Test Result.....	218
A.8	AC Conducted Emissions Test Result	442
Appendix B – Test Setup Photograph		444
Appendix C – EUT Photograph		445

1.4. Product Information

Product Name	ACCESS POINT	
Model No.	APINR605	
Serial No.	CNP6L8M02S (Conducted Testing) CNP6L8M00G (Radiated Testing)	
Software Version	RAJB-AB05 V1.6.2	
Wi-Fi Specification	802.11a/b/g/n/ac/ax	
Bluetooth Specification	v5.0 single mode, BLE only	
Zigbee Specification	802.15.4	
Antenna Information	Refer to section 1.7	
Power Type	AC/DC Adapter input	
Operating Environment	<input checked="" type="checkbox"/> Indoor Use	<input type="checkbox"/> Outdoor Use
Accessories		
AC/DC Adapter	Model: ADP-50GR BD Input: 100 ~ 240V 1.3A 50 – 60Hz Output: 48V 1.042A 50.016W	
Optional Integrated Modular	Modular Name: LTE-A Cat 12 M.2 Module Mode No.: APINCM12 Contain FCC ID: XMR201901EM12G Supported UTRA Band: 2, 4, 5 Supported E-UTRA Band: FDD Band: 2, 4, 5, 7, 12, 13, 14, 17, 25, 26, 30, 66, TDD Band: 38, 41	
Note: The information of EUT was provided by the manufacturer, and the accuracy of the information shall be the responsibility of the manufacturer.		

1.5. Radio Specification under Test

Frequency Range	802.11b/g/n-HT20/ax-HE20: 2412 ~ 2462MHz 802.11n-HT40/ax-HE40: 2422 ~ 2452MHz	
Channel Number	802.11b/g/n-HT20/ax-HE20: 11 802.11n-HT40/ax-HE40: 7	
Type of Modulation	802.11b: DSSS 802.11g/n: OFDM 802.11ax: OFDMA	
Data Rate	802.11b: 1/2/5.5/11Mbps 802.11g: 6/9/12/18/24/36/48/54Mbps 802.11n: up to 300Mbps 802.11ax: up to 574Mbps	
Channel Puncturing Function	<input type="checkbox"/> Supported	<input checked="" type="checkbox"/> Unsupported
Support RU	<input checked="" type="checkbox"/> Full RU	<input type="checkbox"/> Partial RU

1.6. Working Frequencies

802.11b/g/n-HT20/ax-HE20

Channel	Frequency	Channel	Frequency	Channel	Frequency
01	2412 MHz	02	2417 MHz	03	2422 MHz
04	2427 MHz	05	2432 MHz	06	2437 MHz
07	2442 MHz	08	2447 MHz	09	2452 MHz
10	2457 MHz	11	2462 MHz	--	--

802.11n-HT40/ax-HE40

Channel	Frequency	Channel	Frequency	Channel	Frequency
03	2422 MHz	04	2427 MHz	05	2432 MHz
06	2437 MHz	07	2442 MHz	08	2447 MHz
09	2452 MHz	--	--	--	--

1.7. Antenna Details

Antenna Type	Frequency Band (GHz)	Tx Paths	CDD Dir Gain (dBi)		BF Dir Gain (dBi)
			For Power	For PSD	
Wi-Fi Antenna					
PIFA	2.4 ~ 2.5	2	4.4	7.4	7.4
	5.15 ~ 5.9	2	4.7	7.6	7.6
	5.9 ~ 7.2	2	4.7	7.7	7.7

Note:

- 1, The EUT supports Cyclic Delay Diversity (CDD) mode, and CDD signals are correlated.
- 2, The EUT also supports Beam Forming mode, and the Beam Forming support 802.11n/ac/ax, not include 802.11a/b/g.
3. For beamforming operation, Aruba OS automatically backs power down based on a $10\log(N)$ factor based on CDD power.
4. The detail calculation method of directional gain refer to antenna specification provided by the applicant.

1.8. Description of EUT Filter

Filter	Specification	Remark
Wi-Fi		
Filter 1#	Band Pass Filter (2412-2472)	Allowing any transmission on all channels
Filter 2#	Band Pass Filter (2402-2447)	Allowing any transmission on 20MHz channels 1 thru 6 and 40MHz channel 3.
Filter 3#	Band Pass Filter (2452-2472)	Allowing any transmission on 20MHz channel 11
Filter 4#	Band Pass Filter (5150-5895)	Allowing any transmission on all channels
Filter 5#	Band Pass Filter (5150-5835)	Allowing any transmission on UNII Band 1/2a/2c/3
Filter 6#	Band Pass Filter (5925-7125)	Allowing any transmission on UNII Band 5/6/7/8
Bluetooth / ZigBee		
Filter 7#	Band Pass Filter (2402-2480)	Allowing any transmission on all channels
Filter 8#	Band Pass Filter (2402-2430)	Allowing transmission on BLE channels 37 (2402MHz) and 38 (2426MHz) and Zigbee channel 11 (2405MHz)
Filter 9#	Band Pass Filter (2478-2482)	Allowing transmission on BLE channel 39 (2480MHz) and Zigbee channel 26(2480MHz)
Note: ZigBee and BLE can't work simultaneously.		

Working Mode

	Radio 0	Radio 1	BLE/ZigBee
1	2.4G_Full Band (Filter 1#)	6G_Full Band (Filter 6#)	---
2	---	6G_Full Band (Filter 6#)	2.4G_Full Band (Filter 7#)
3	2.4G_Low Band (Filter 2#)	6G_Full Band (Filter 6#)	2.4G_High Band (Filter 9#)
4	2.4G_High Band (Filter 3#)	6G_Full Band (Filter 6#)	2.4G_Low Band (Filter 8#)
5	5G_Full Band (Filter 4#)	2.4G_Full Band (Filter 1#)	---
6	5G_Full Band (Filter 4#)	---	2.4G_Full Band (Filter 7#)
7	5G_Full Band (Filter 4#)	2.4G_Low Band (Filter 2#)	2.4G_High Band (Filter 9#)
8	5G_Full Band (Filter 4#)	2.4G_High Band (Filter 3#)	2.4G_Low Band (Filter 8#)
9	5G_Full Band (Filter 5#)	6G_Full Band (Filter 6#)	2.4G_Full Band (Filter 1#)
10	5G_Full Band (Filter 5#)	6G_Full Band (Filter 6#)	2.4G_Full Band (Filter 1#)
11	5G_Full Band (Filter 5#)	6G_Full Band (Filter 6#)	2.4G_Full Band (Filter 1#)
12	5G_Full Band (Filter 5#)	6G_Full Band (Filter 6#)	2.4G_Full Band (Filter 1#)

2. Test Configuration

2.1. Test Mode

Mode 1: Transmit by 802.11b_Nss=1 (1Mbps) _ Radio 0
Mode 2: Transmit by 802.11g_Nss=1 (6Mbps) _ Radio 0
Mode 3: Transmit by 802.11n-HT20_Nss=1 (MCS0) _ Radio 0
Mode 4: Transmit by 802.11n-HT40_Nss=1 (MCS0) _ Radio 0
Mode 5: Transmit by 802.11ax-HE20_Nss=1 (MCS0) _ Radio 0
Mode 6: Transmit by 802.11ax-HE40_Nss=1 (MCS0) _ Radio 0
Mode 7: Transmit by 802.11b_Nss=1 (1Mbps) _ Radio 1
Mode 8: Transmit by 802.11g_Nss=1 (6Mbps) _ Radio 1
Mode 9: Transmit by 802.11n-HT20_Nss=1 (MCS0) _ Radio 1
Mode 10: Transmit by 802.11n-HT40_Nss=1 (MCS0) _ Radio 1
Mode 11: Transmit by 802.11ax-HE20_Nss=1 (MCS0) _ Radio 1
Mode 12: Transmit by 802.11ax-HE40_Nss=1 (MCS0) _ Radio 1
Note 1: All modes of operation and data rates were investigated, so all RF test requirements shall be executed at the worst data rate.
Note 2: For beamforming operation, manufacturer automatically backs power down based on a $10\log(N_{ANT})$ factor based on CDD power. Therefore, only the CDD mode was evaluated in this report

2.2. Test System Connection Diagram

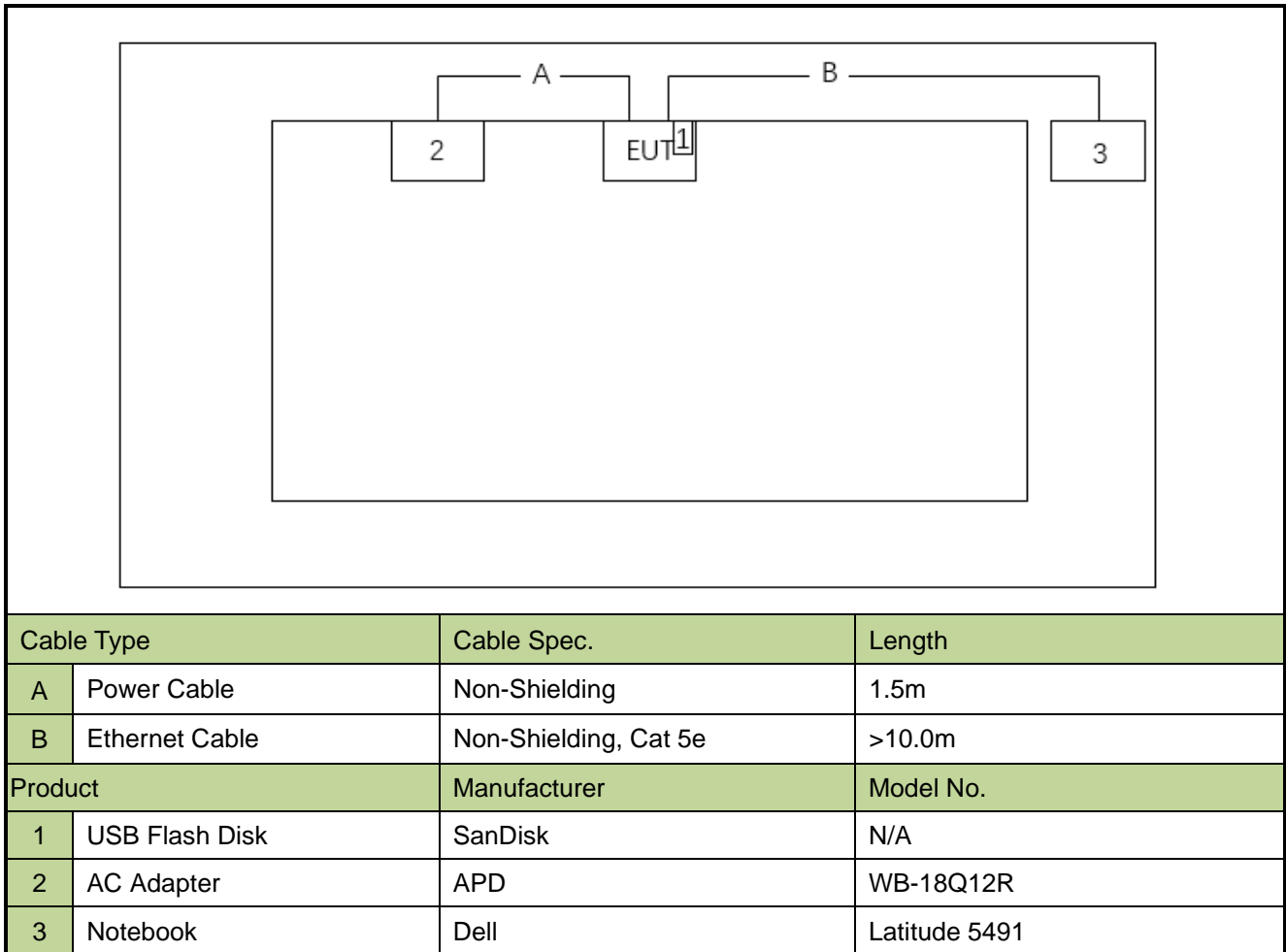

2.3. Test Software

The test utility software used during testing was “accessMTool”, and the version was 3.2.1.5.

Note: Final power setting please refer to operational description.

2.4. Applied Standards

According to the specifications of the manufacturer, the EUT must comply with the requirements of the following standards:

- FCC Part 15.247
- KDB 558074 D01v05r02
- ANSI C63.10-2013

2.5. Test Environment Condition

Ambient Temperature	15 ~ 35°C
Relative Humidity	20 ~ 75%RH

3. Antenna Requirements

Excerpt from §15.203 of the FCC Rules/Regulations:

“An intentional radiator antenna shall be designed to ensure that no antenna other than that furnished by the responsible party can be used with the device. The use of a permanently attached antenna or of an antenna that uses a unique coupling to the intentional radiator shall be considered sufficient to comply with the provisions of this section.”

- The antenna of the device is **permanently attached**.
- There are no provisions for connection to an external antenna.

Conclusion:

The unit complies with the requirement of §15.203.

4. Measuring Instrument

Instrument	Manufacturer	Model No.	Asset No.	Cali. Interval	Cali. Due Date	Test Site
TRILOG Antenna	Schwarzbeck	VULB 9162	MRTSUE06022	1 year	2023-05-20	WZ-AC2
EMI Test Receiver	Agilent	N9038A	MRTSUE06125	1 year	2023-06-04	WZ-AC2
Thermohygrometer	Mingle	ETH529	MRTSUE06170	1 year	2023-11-27	WZ-AC2
Horn Antenna	Schwarzbeck	BBHA 9120D	MRTSUE06171	1 year	2023-10-13	WZ-AC2
Preamplifier	Schwarzbeck	BBV 9718	MRTSUE06176	1 year	2023-05-08	WZ-AC2
Anechoic Chamber	RIKEN	WZ-AC2	MRTSUE06213	1 year	2023-04-21	WZ-AC2
Thermohygrometer	testo	608-H1	MRTSUE11038	1 year	2023-11-01	WZ-AC2
Loop Antenna	Schwarzbeck	FMZB 1519	MRTSUE06025	1 year	2023-09-29	WZ-AC2
Horn Antenna	Schwarzbeck	BBHA 9170	MRTSUE06597	1 year	2023-11-05	WZ-AC2
Preamplifier	EMCI	EMC184045SE	MRTSUE06640	1 year	2024-01-12	WZ-AC2
EMI Test Receiver	R&S	ESR7	MRTSUE06001	1 year	2023-12-28	WZ-AC1
Horn Antenna	Schwarzbeck	BBHA 9120D	MRTSUE06023	1 year	2023-08-22	WZ-AC1
Preamplifier	Agilent	83017A	MRTSUE06076	1 year	2023-05-08	WZ-AC1
TRILOG Antenna	Schwarzbeck	VULB 9168	MRTSUE06172	1 year	2023-06-21	WZ-AC1
Anechoic Chamber	TDK	WZ-AC1	MRTSUE06212	1 year	2023-04-21	WZ-AC1
Thermohygrometer	testo	608-H1	MRTSUE06403	1 year	2023-06-06	WZ-AC1
Signal Analyzer	Keysight	N9010B	MRTSUE06607	1 year	2023-12-28	WZ-AC1
Thermohygrometer	testo	608-H1	MRTSUE11039	1 year	2023-11-01	WZ-AC1
Signal Generator	Agilent	E4438C	MRTSUE06081	1 year	2024-02-29	WZ-SR5
Thermohygrometer	testo	608-H1	MRTSUE06402	1 year	2023-06-06	WZ-SR5
Shielding Room	HUAMING	WZ-SR5	MRTSUE06442	N/A	N/A	WZ-SR5
Signal Analyzer	Keysight	N9010B	MRTSUE06457	1 year	2023-06-04	WZ-SR5
Attenuator	MVE	MVE2213	MRTSUE11073	1 year	2023-06-09	WZ
Attenuator	MVE	MVE2213	MRTSUE11074	1 year	2023-06-09	WZ
Attenuator	MVE	MVE2213	MRTSUE11086	1 year	2023-06-09	WZ
Attenuator	MVE	MVE2213	MRTSUE11087	1 year	2023-06-09	WZ

Software	Version	Function
EMI Software	V3.0.0	EMI Test Software
BenchVue Power Meter	2018.1	Power
Controller_MF 7802	1.02	RE Antenna & Turntable

5. Decision Rules and Measurement Uncertainty

5.1. Decision Rules

The Decision Rule is based on Simple Acceptance in accordance with ISO Guide 98-4: 2012 Clause 8.2. (Measurement uncertainty is not taken into account when stating conformity with a specified requirement.)

5.2. Measurement Uncertainty

Where relevant, the following test uncertainty levels have been estimated for tests performed on the EUT as specified in CISPR 16-4-2. This uncertainty represents an expanded uncertainty expressed at approximately the 95% confidence level using a coverage factor of $k = 2$.

AC Conducted Emission Measurement
The maximum measurement uncertainty is evaluated as: 9kHz~150kHz: 3.58dB 150kHz~30MHz: 3.20dB
Radiated Emission Measurement
The maximum measurement uncertainty is evaluated as: Coaxial: 9kHz~30MHz: 2.59dB Coplanar: 9kHz~30MHz: 2.60dB Horizontal: 30MHz~200MHz: 3.85dB 200MHz~1GHz: 4.36dB 1GHz~40GHz: 4.98dB Vertical: 30MHz~200MHz: 4.06dB 200MHz~1GHz: 5.28dB 1GHz~40GHz: 4.91dB
Spurious Emissions, Conducted
Measuring Uncertainty for a Level of Confidence of 95% ($U=2Uc(y)$): 2.3dB
Output Power
Measuring Uncertainty for a Level of Confidence of 95% ($U=2Uc(y)$): 1.5dB
Power Spectrum Density
Measuring Uncertainty for a Level of Confidence of 95% ($U=2Uc(y)$): 2.3dB
Occupied Bandwidth
Measuring Uncertainty for a Level of Confidence of 95% ($U=2Uc(y)$): 3.2%

6. Test Result

6.1. Summary

FCC Section(s)	Test Description	Test Condition	Verdict
15.247(a)(2)	6dB Bandwidth	Conducted	Pass
15.247(b)(3)	Output Power		Pass
15.247(e)	Power Spectral Density		Pass
15.247(d)	Band Edge / Out-of-Band Emissions		Pass
15.205 15.209	General Field Strength (Restricted Bands and Radiated Emission)	Radiated	Pass
15.207	AC Conducted Emissions 150kHz - 30MHz	Line Conducted	Pass

Notes:

- The analyzer plots shown in this section were all taken with a correction table loaded into the analyzer. The correction table was used to account for the losses of the cables and attenuators used as part of the system to connect the EUT to the analyzer at all frequencies of interest.
- For radiated emission tests, every axis (X, Y, Z) was also verified. The test results shown in the following sections represent the worst-case emissions.

Test Items	Filter 1#	Filter 2#	Filter 3#
6dB Bandwidth	•		
Output Power	•	•	•
Power Spectral Density	•		
Band Edge / Out-of-Band Emissions	•	•	•
Radiated Spurious Emission	•	•	•
Radiated Band Edge	•	•	•
AC Conducted Emissions 150kHz - 30MHz	•		

6.2. 6dB Bandwidth Measurement

6.2.1. Test Limit

The minimum 6dB bandwidth shall be at least 500 kHz.

6.2.2. Test Procedure

ANSI C63.10 - 2013 - Section 11.8

6.2.3. Test Setting

1. The Spectrum's automatic bandwidth measurement capability was used to perform the 6dB bandwidth measurement. The "X" dB bandwidth parameter was set to $X = 6$. The bandwidth measurement was not influenced by any intermediate power nulls in the fundamental emission.
2. Set RBW = 100 kHz
3. VBW $\geq 3 \times$ RBW
4. Detector = Peak
5. Trace mode = Max hold
6. Sweep = Auto couple
7. Allow the trace to stabilize

6.2.4. Test Setup

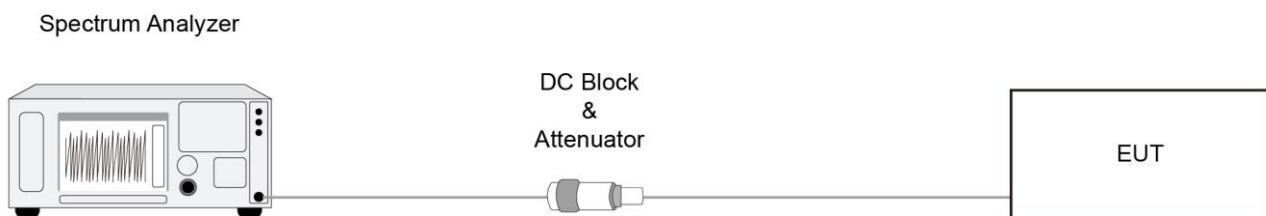

6.2.5. Test Result

Refer to Appendix A.2.

6.3. Output Power Measurement

6.3.1. Test Limit

The maximum output power shall be less 1 Watt (30dBm).

The conducted output power limit specified in paragraph FCC Part 15.247(b) of this section is based on the use of antennas with directional gains that do not exceed 6 dBi. If transmitting antennas of directional gain greater than 6 dBi are used, the conducted output power from the intentional radiator shall be reduced below the stated values in paragraphs FCC Part 15.247(b)(3) of this section, as appropriate, by the amount in dB that the directional gain of the antenna exceeds 6 dBi.

6.3.2. Test Procedure

ANSI C63.10 - 2013 - Section 11.9.2.3.2

6.3.3. Test Setting

Average Power Measurement

Average power measurements were performed only when the EUT was transmitting at its maximum power control level using a broadband power meter with a pulse sensor. The power meter implemented triggering and gating capabilities which were set up such that power measurements were recorded only during the ON time of the transmitter.

6.3.4. Test Setup

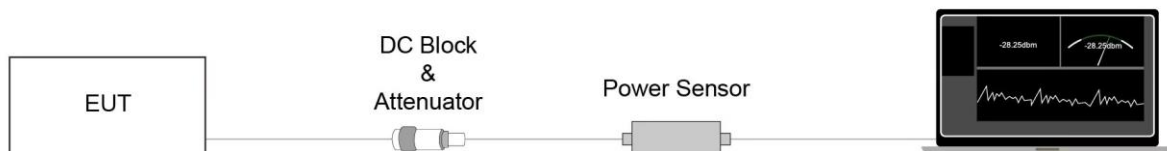

6.3.5. Test Result

Refer to Appendix A.3.

6.4. Power Spectral Density Measurement

6.4.1. Test Limit

The maximum permissible power spectral density is 8dBm in any 3 kHz band.

The same method of determining the conducted output power shall be used to determine the power spectral density.

6.4.2. Test Procedure

ANSI C63.10 - 2013 - Section 11.10.5

6.4.3. Test Setting

1. Measure the duty cycle (x) of the transmitter output signal.
2. Set instrument center frequency to DTS channel center frequency.
3. Set span to at least 1.5 times the OBW.
4. RBW = 10 kHz.
5. VBW = 30 kHz.
6. Detector = RMS.
7. Ensure that the number of measurement points in the sweep $\geq 2 \times \text{span}/\text{RBW}$.
8. Sweep time = auto couple.
9. Don't use sweep triggering. Allow sweep to "free run".
10. Employ trace averaging (RMS) mode over a minimum of 100 traces.
11. Use the peak marker function to determine the maximum amplitude level.
12. Add $10 \log (1/x)$, where x is the duty cycle measured in step (a), to the measured PSD to compute the average PSD during the actual transmission time. If measured value exceeds requirement specified by regulatory agency, then reduce RBW (but no less than 3 kHz) and repeat (note that this may require zooming in on the emission of interest and reducing the span to meet the minimum measurement point requirement as the RBW is reduced).

6.4.4. Test Setup

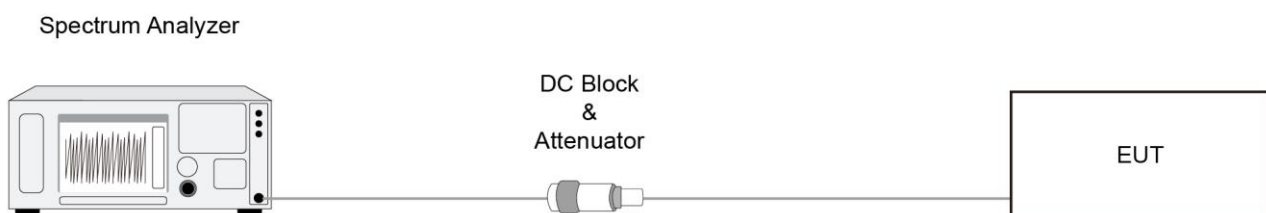

6.4.5. Test Result

Refer to Appendix A.4.

6.5. Conducted Band Edge and Out-of-Band Emissions Measurement

6.5.1. Test Limit

The limit for out-of-band spurious emissions at the band edge is 20dB below the fundamental emission level, as determined from the in-band power measurement of the DTS channel performed in a 100 kHz bandwidth per the PSD procedure.

6.5.2. Test Procedure

ANSI C63.10-2013 - Section 11.11

6.5.3. Test Setting

Reference level measurement

1. Set instrument center frequency to DTS channel center frequency
2. Set the span to ≥ 1.5 times the DTS bandwidth
3. Set the RBW = 100 kHz
4. Set the VBW $\geq 3 \times$ RBW
5. Detector = peak
6. Sweep time = auto couple
7. Trace mode = max hold
8. Allow trace to fully stabilize

Emission level measurement

1. Set the center frequency and span to encompass frequency range to be measured
2. RBW = 100kHz
3. VBW = 300kHz
4. Detector = Peak
5. Trace mode = max hold
6. Sweep time = auto couple
7. The trace was allowed to stabilize

6.5.4. Test Setup

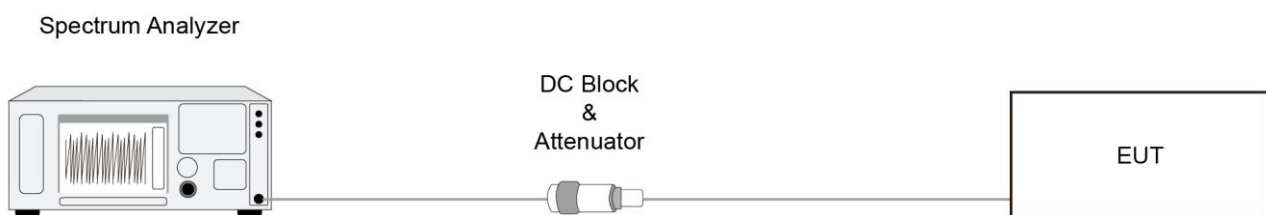

6.5.5. Test Result

Refer to Appendix A.5.

6.6. Radiated Spurious Emission Measurement

6.6.1. Test Limit

All out of band emissions appearing in a restricted band as specified in Section 15.205 of the Title 47 CFR must not exceed the limits shown in Table per Section 15.209.

FCC Part 15 Subpart C Paragraph 15.209		
Frequency [MHz]	Field Strength [uV/m]	Measured Distance [Meters]
0.009 - 0.490	2400/F (kHz)	300
0.490 - 1.705	24000/F (kHz)	30
1.705 - 30	30	30
30 - 88	100	3
88 - 216	150	3
216 - 960	200	3
Above 960	500	3

6.6.2. Test Procedure

ANSI C63.10 - 2013 - Section 11.11 & 11.12

ANSI C63.10 - 2013 - Section 6.3 (General Requirements)

ANSI C63.10 - 2013 - Section 6.4 (Standard test method below 30MHz)

ANSI C63.10 - 2013 - Section 6.5 (Standard test method above 30MHz to 1GHz)

ANSI C63.10 - 2013 - Section 6.6 (Standard test method above 1GHz)

6.6.3. Test Setting

Table 1 - RBW as a function of frequency

Frequency	RBW
9 ~ 150 kHz	200 ~ 300 Hz
0.15 ~ 30 MHz	9 ~ 10 kHz
30 ~ 1000 MHz	100 ~ 120 kHz
> 1000MHz	1MHz

Quasi-Peak Measurements below 1GHz

1. Analyzer center frequency was set to the frequency of the radiated spurious emission of interest

2. Span was set greater than 1MHz
3. RBW = as specified in Table 1
4. Detector = CISPR quasi-peak
5. Sweep time = auto couple
6. Trace was allowed to stabilize

Peak Measurements above 1GHz

1. Analyzer center frequency was set to the frequency of the radiated spurious emission of interest
2. RBW = 1MHz
3. VBW = 3MHz
4. Detector = peak
5. Sweep time = auto couple
6. Trace mode = max hold
7. Trace was allowed to stabilize

Average Measurements above 1GHz (Method VB)

1. Analyzer center frequency was set to the frequency of the radiated spurious emission of interest
2. RBW = 1MHz
3. VBW; If the EUT is configured to transmit with duty cycle $\geq 98\%$, set VBW = 10 Hz.
If the EUT duty cycle is $< 98\%$, set VBW $\geq 1/T$. T is the minimum transmission duration.

Radio 0			
802.11b	VBW = 82Hz	802.11g	VBW = 510Hz
802.11n-HT20	VBW = 560Hz	802.11n-HT40	VBW = 1100Hz
802.11ax-HE20	VBW = 680Hz	802.11ax-HE40	VBW = 1500Hz
Radio 1			
802.11b	VBW = 82Hz	802.11g	VBW = 510Hz
802.11n-HT20	VBW = 560Hz	802.11n-HT40	VBW = 1100Hz
802.11ax-HE20	VBW = 680Hz	802.11ax-HE40	VBW = 1300Hz

4. Detector = Peak
5. Sweep time = auto
6. Trace mode = max hold
7. Trace was allowed to stabilize

6.6.4. Test Setup

Below 30MHz Test Setup:

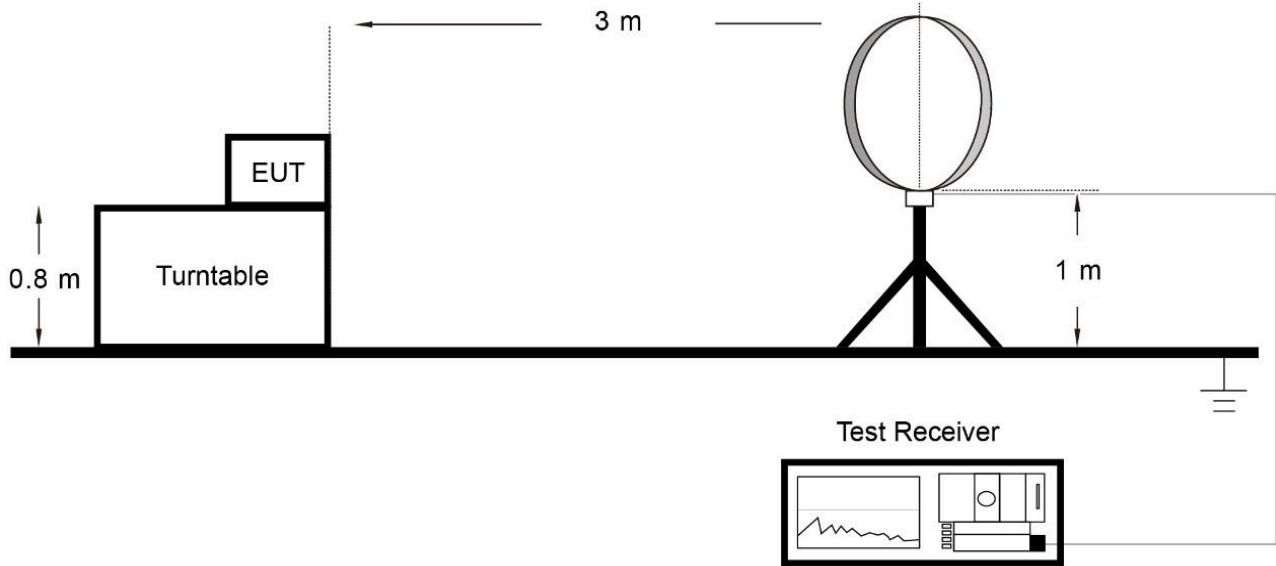

Below 1GHz Test Setup:

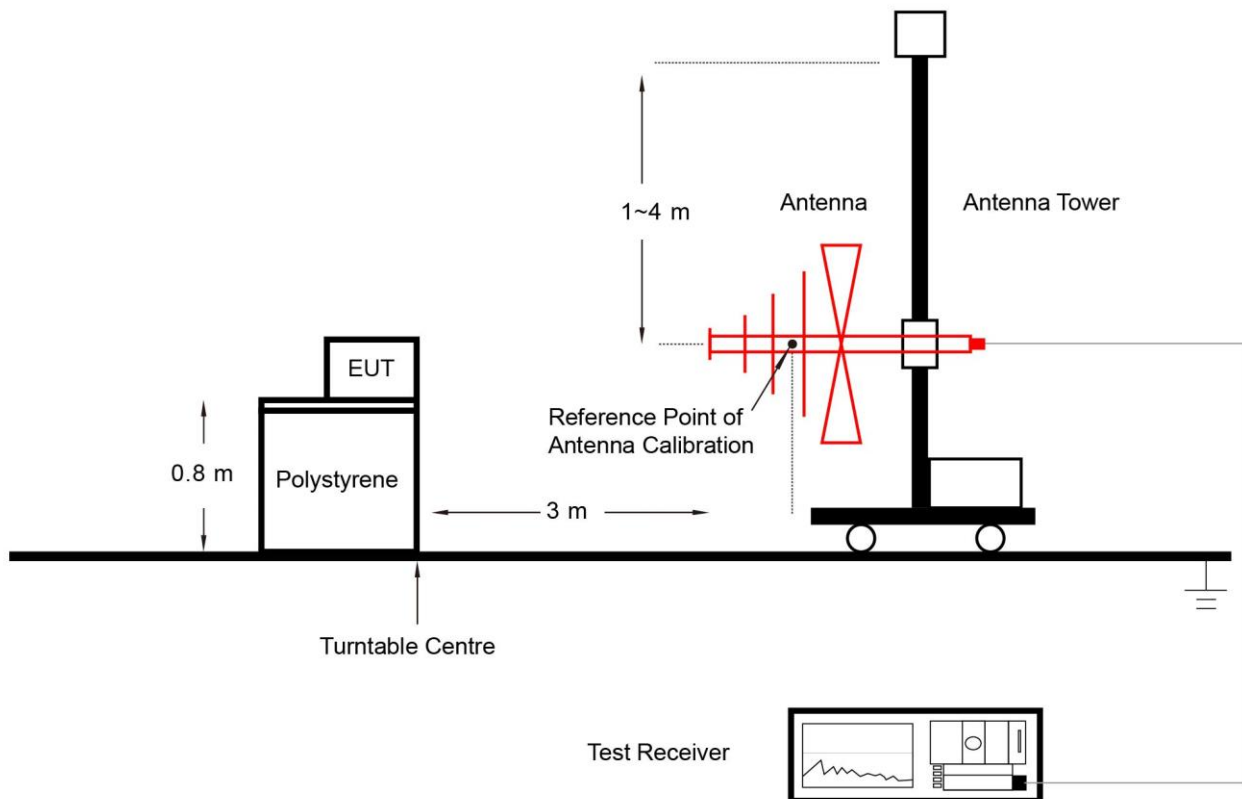

Above 1GHz Test Setup:

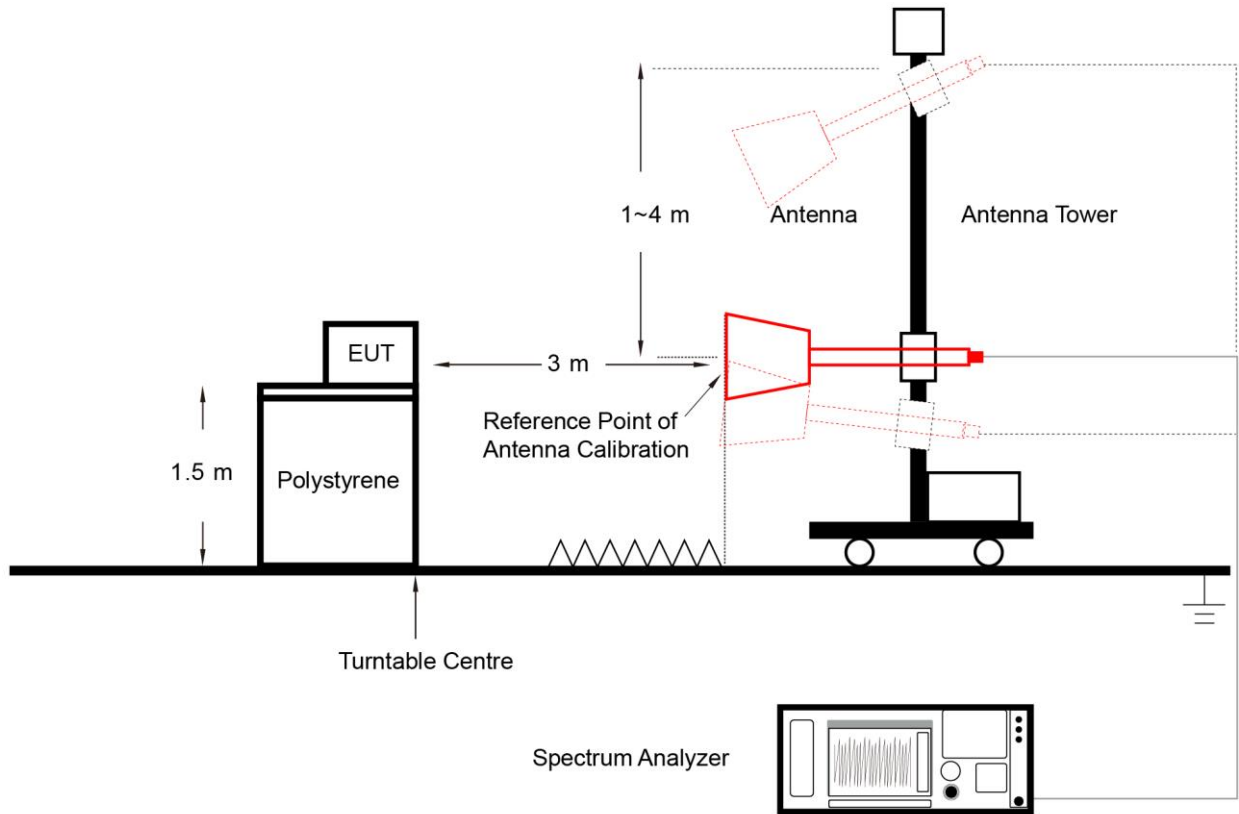

6.6.5. Test Result

Refer to Appendix A.6.

6.7. Radiated Restricted Band Edge Measurement

6.7.1. Test Limit

For 15.205 requirement:

Radiated emissions which fall in the restricted bands, as defined in Section 15.205(a) of FCC part 15, must also comply with the radiated emission limits specified in Section 15.209(a).

Frequency (MHz)	Frequency (MHz)	Frequency (MHz)	Frequency (GHz)
0.090 - 0.110	16.42 - 16.423	399.9 - 410	4.5 - 5.15
¹ 0.495 - 0.505	16.69475 - 16.69525	608 - 614	5.35 - 5.46
2.1735 - 2.1905	16.80425 - 16.80475	960 - 1240	7.25 - 7.75
4.125 - 4.128	25.5 - 25.67	1300 - 1427	8.025 - 8.5
4.17725 - 4.17775	37.5 - 38.25	1435 - 1626.5	9.0 - 9.2
4.20725 - 4.20775	73 - 74.6	1645.5 - 1646.5	9.3 - 9.5
6.215 - 6.218	74.8 - 75.2	1660 - 1710	10.6 - 12.7
6.26775 - 6.26825	108 - 121.94	1718.8 - 1722.2	13.25 - 13.4
6.31175 - 6.31225	123 - 138	2200 - 2300	14.47 - 14.5
8.291 - 8.294	149.9 - 150.05	2310 - 2390	15.35 - 16.2
8.362 - 8.366	156.52475 - 156.52525	2483.5 - 2500	17.7 - 21.4
8.37625 - 8.38675	156.7 - 156.9	2690 - 2900	22.01 - 23.12
8.41425 - 8.41475	162.0125 - 167.17	3260 - 3267	23.6 - 24.0
12.29 - 12.293	167.72 - 173.2	3332 - 3339	31.2 - 31.8
12.51975 - 12.52025	240 - 285	3345.8 - 3358	36.43 - 36.5
12.57675 - 12.57725	322 - 335.4	3600 - 4400	(²)
13.36 - 13.41	--	--	--

All out of band emissions appearing in a restricted band as specified in Section 15.205 of the Title 47CFR must not exceed the limits shown in Table per Section 15.209.

FCC Part 15 Subpart C Paragraph 15.209		
Frequency [MHz]	Field Strength [uV/m]	Measured Distance [Meters]
0.009 - 0.490	2400/F (kHz)	300
0.490 - 1.705	24000/F (kHz)	30
1.705 - 30	30	30
30 - 88	100	3
88 - 216	150	3
216 - 960	200	3
Above 960	500	3

6.7.2. Test Procedure

ANSI C63.10-2013 Section 6.3 & 6.6 & 11.13

6.7.3. Test Setting

Peak Field Strength Measurements

1. Analyzer center frequency was set to the frequency of the radiated spurious emission of interest
2. RBW = 1MHz
3. VBW = 3MHz
4. Detector = peak
5. Sweep time = auto couple
6. Trace mode = max hold
7. Trace was allowed to stabilize

Average Field Strength Measurements

1. Analyzer center frequency was set to the frequency of the radiated spurious emission of interest
2. RBW = 1MHz
3. $VBW \geq 1/T$; If the EUT is configured to transmit with duty cycle $\geq 98\%$, set $VBW = 10$ Hz.

If the EUT duty cycle is $< 98\%$, set $VBW \geq 1/T$. T is the minimum transmission duration.

Radio 0			
802.11b	VBW = 82Hz	802.11g	VBW = 510Hz
802.11n-HT20	VBW = 560Hz	802.11n-HT40	VBW = 1100Hz
802.11ax-HE20	VBW = 680Hz	802.11ax-HE40	VBW = 1500Hz
Radio 1			
802.11b	VBW = 82Hz	802.11g	VBW = 510Hz
802.11n-HT20	VBW = 560Hz	802.11n-HT40	VBW = 1100Hz
802.11ax-HE20	VBW = 680Hz	802.11ax-HE40	VBW = 1300Hz

4. Average Type = Voltage
5. Detector = Peak
6. Sweep time = auto
7. Trace mode = max hold
8. Allow max hold to run for at least 50 times (1/duty cycle) traces

6.7.4. Test Setup

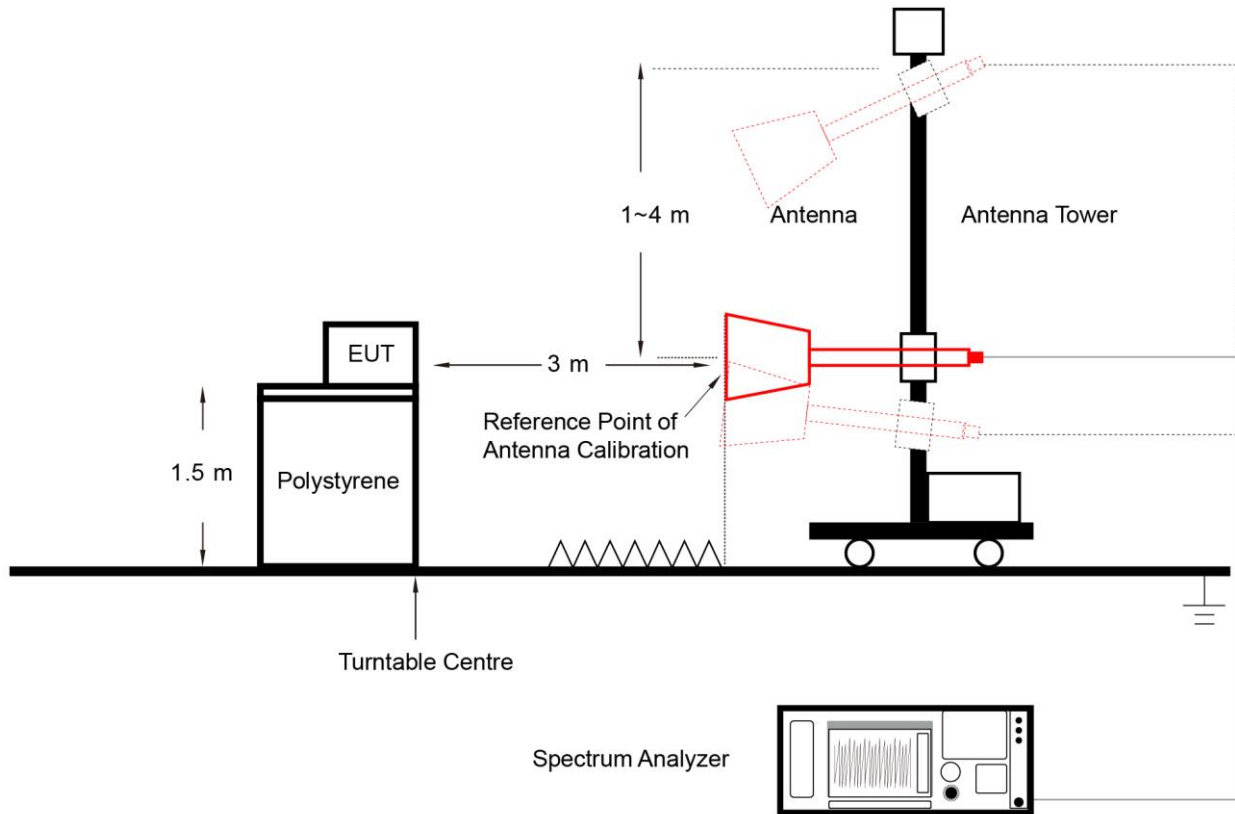

6.7.5. Test Result

Refer to Appendix A.7.

6.8. AC Conducted Emissions Measurement

6.8.1. Test Limit

FCC Part 15 Subpart C Paragraph 15.207 Limits		
Frequency (MHz)	QP (dBuV)	AV (dBuV)
0.15 - 0.50	66 - 56	56 - 46
0.50 - 5.0	56	46
5.0 - 30	60	50

Note 1: The lower limit shall apply at the transition frequencies.

Note 2: The limit decreases linearly with the logarithm of the frequency in the range 0.15MHz to 0.5MHz.

6.8.2. Test Setup

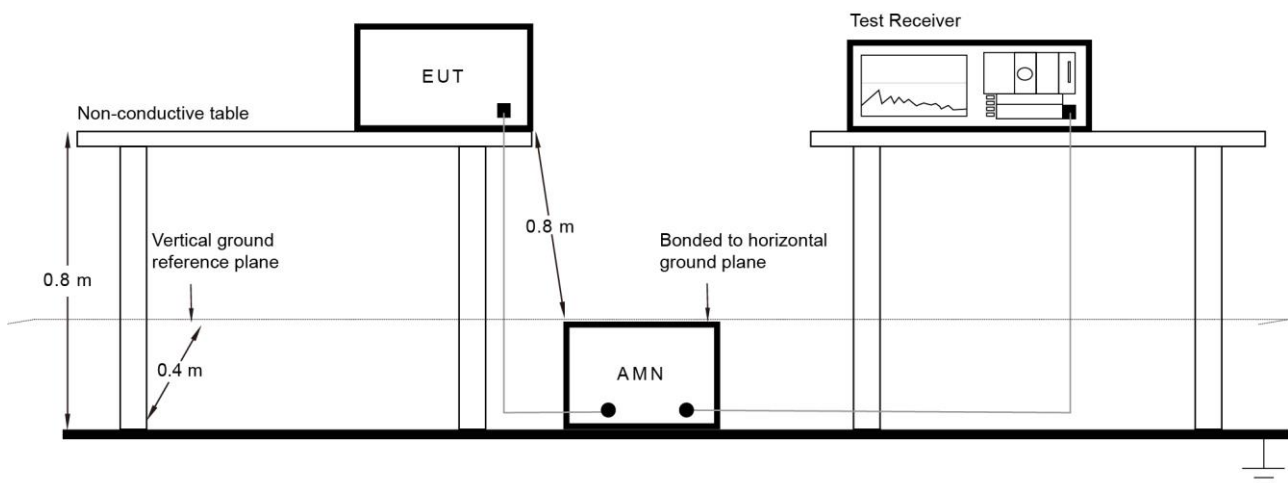

6.8.3. Test Result

Refer to Appendix A.8.

Appendix A – Test Result

A.1 Duty Cycle Test Result

Test Site	WZ-SR5	Test Engineer	Lynn Yang
Test Date	2022-10-19	Test Mode	Radio 0

Test Mode	Duty Cycle
802.11b	94.25%
802.11g	94.12%
802.11n-HT20	94.75%
802.11n-HT40	89.80%
802.11ax-HE20	97.76%
802.11ax-HE40	94.99%

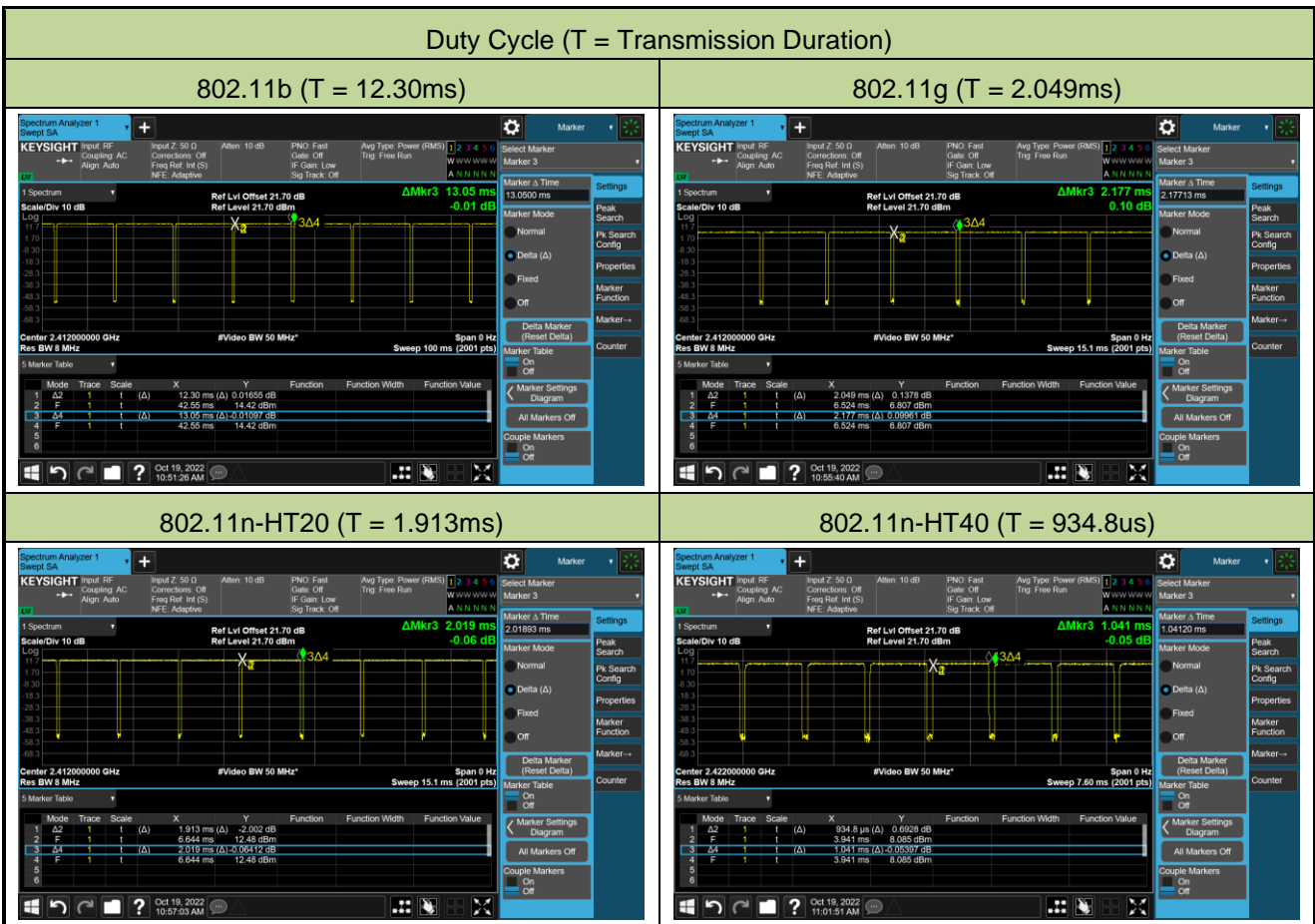

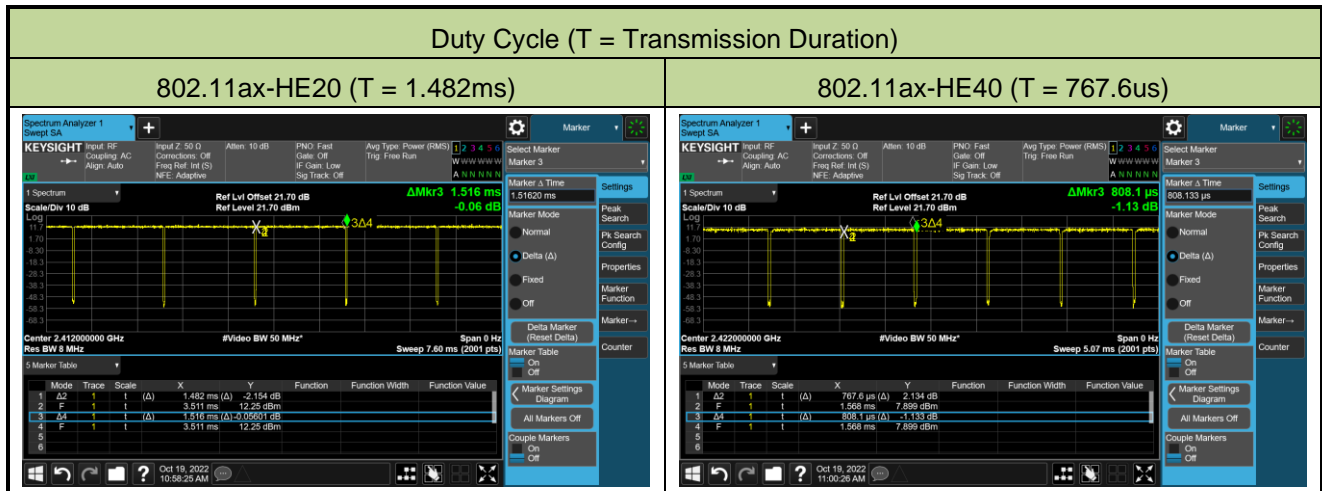

Test Site	WZ-SR5	Test Engineer	Lynn Yang
Test Date	2022-10-19	Test Mode	Radio 1

Test Mode	Duty Cycle
802.11b	94.55%
802.11g	94.70%
802.11n-HT20	94.80%
802.11n-HT40	90.03%
802.11ax-HE20	96.99%
802.11ax-HE40	94.70%

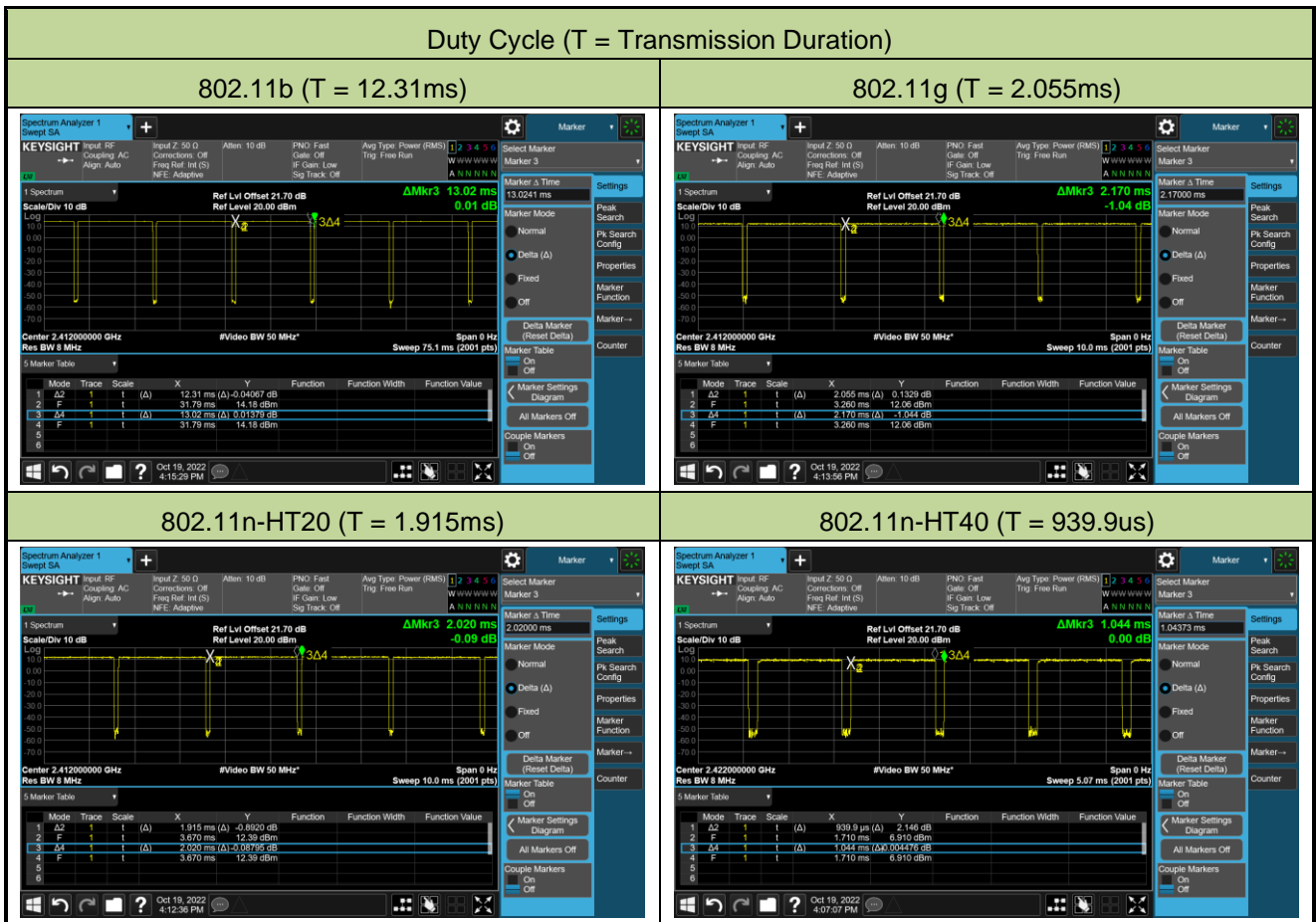

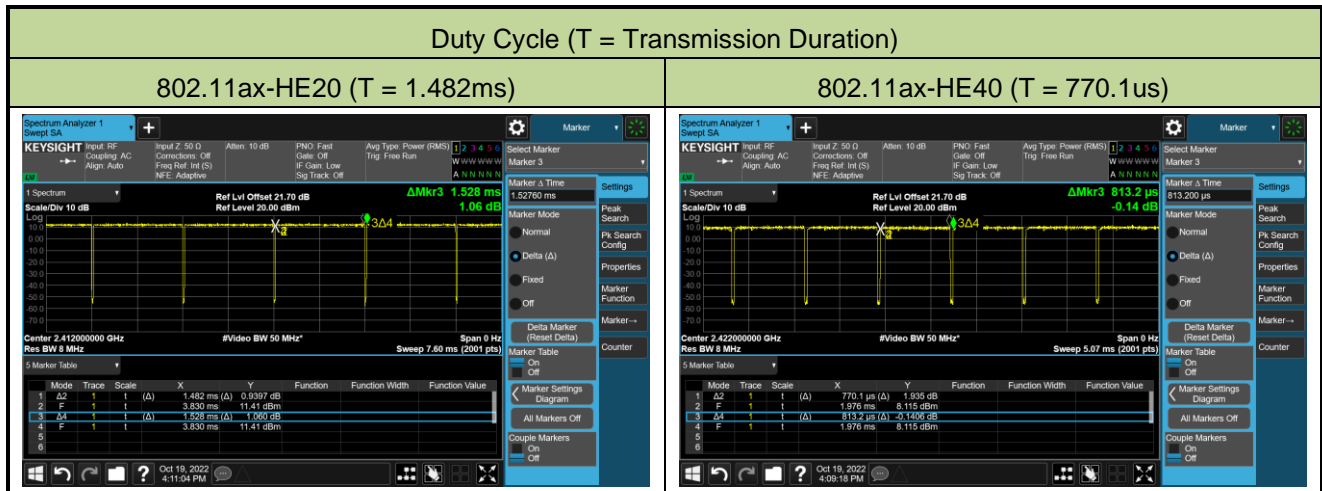

A.2 6dB Bandwidth Test Result

Test Site	WZ-SR5	Test Engineer	Lynn Yang
Test Date	2022-10-21	Test Mode	Radio 0

Test Mode	Data Rate / MCS	Channel No.	Frequency (MHz)	6dB Bandwidth (MHz)	Limit (MHz)
11b	1Mbps	01	2412	7.524	≥ 0.5
11b	1Mbps	06	2437	7.078	≥ 0.5
11b	1Mbps	11	2462	7.073	≥ 0.5
11g	6Mbps	01	2412	16.08	≥ 0.5
11g	6Mbps	06	2437	16.36	≥ 0.5
11g	6Mbps	11	2462	16.36	≥ 0.5
11n-HT20	MCS0	01	2412	17.19	≥ 0.5
11n-HT20	MCS0	06	2437	17.60	≥ 0.5
11n-HT20	MCS0	11	2462	17.60	≥ 0.5
11n-HT40	MCS0	03	2422	35.57	≥ 0.5
11n-HT40	MCS0	06	2437	36.36	≥ 0.5
11n-HT40	MCS0	09	2452	35.76	≥ 0.5
11ax-HE20	MCS0	01	2412	18.66	≥ 0.5
11ax-HE20	MCS0	06	2437	19.05	≥ 0.5
11ax-HE20	MCS0	11	2462	19.00	≥ 0.5
11ax-HE40	MCS0	03	2422	36.02	≥ 0.5
11ax-HE40	MCS0	06	2437	37.35	≥ 0.5
11ax-HE40	MCS0	09	2452	36.85	≥ 0.5

802.11b 6dB Bandwidth

Channel 01 (2412MHz)

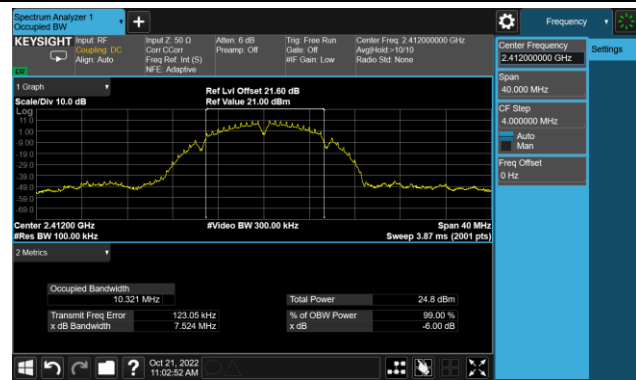

Channel 06 (2437MHz)

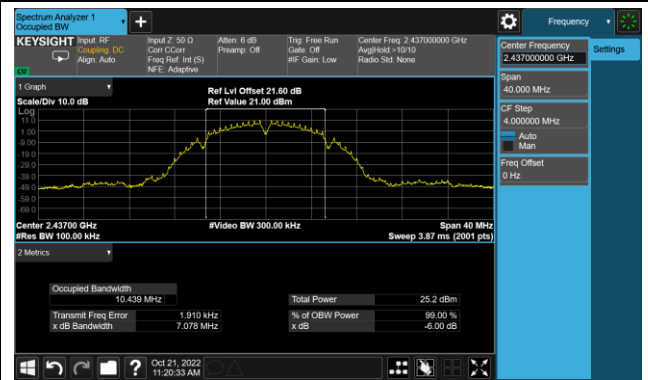

Channel 11 (2462MHz)

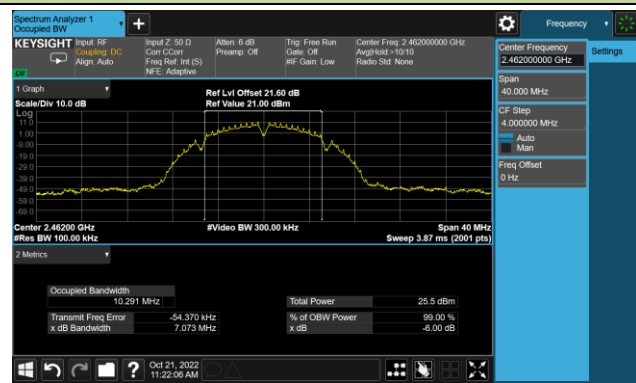

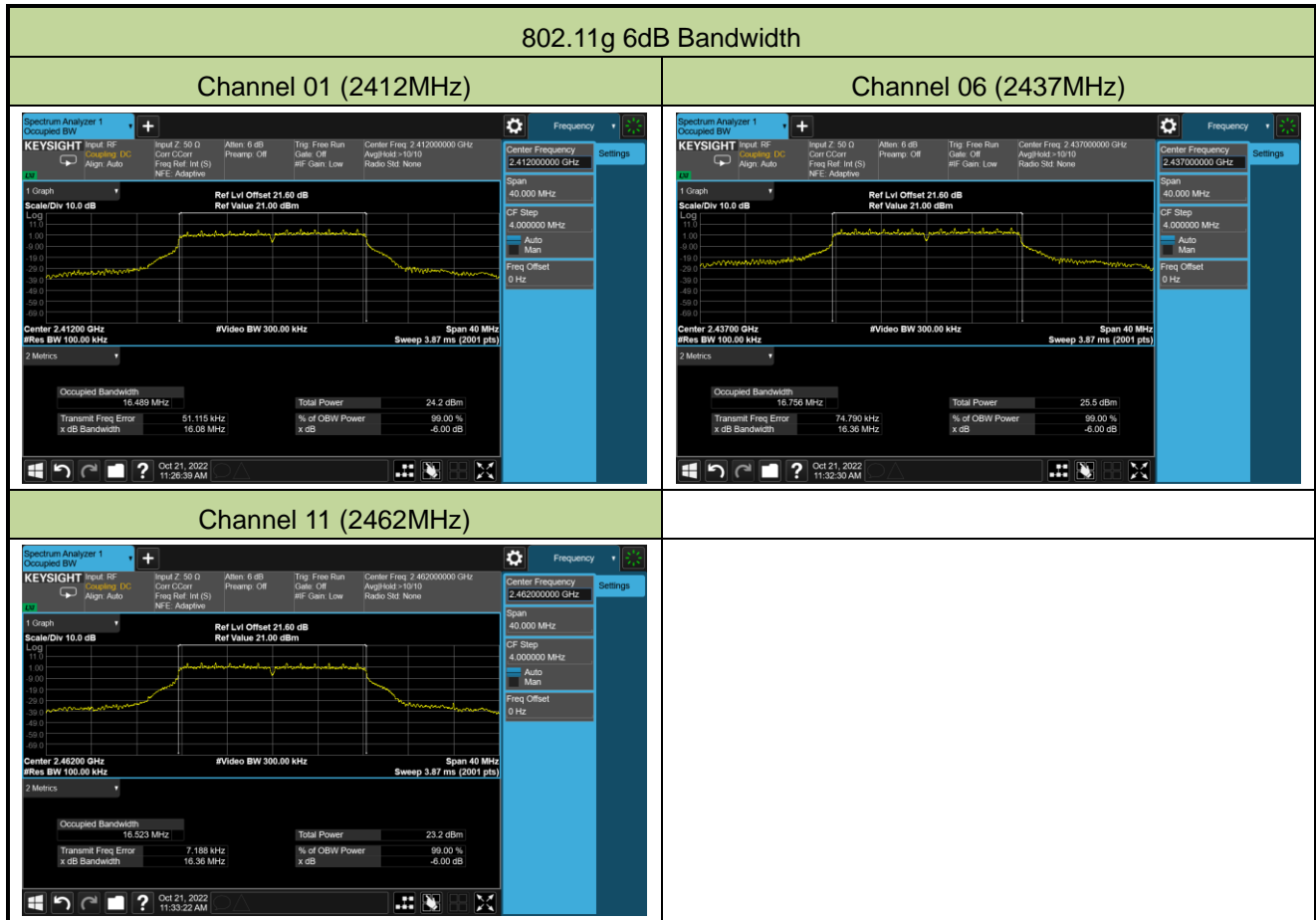

802.11n-HT20 6dB Bandwidth

Channel 01 (2412MHz)

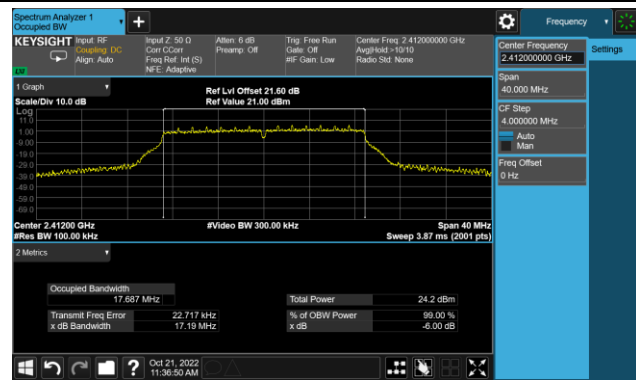

Channel 06 (2437MHz)

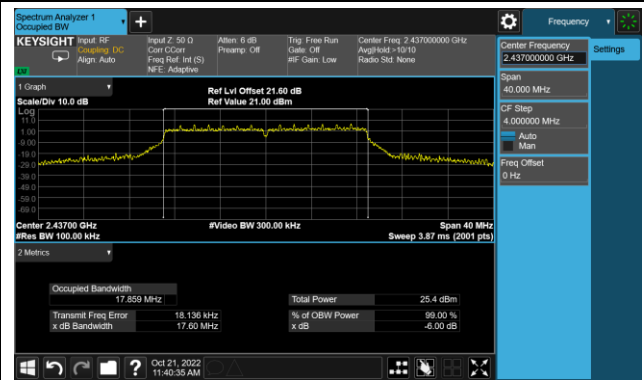

Channel 11 (2462MHz)

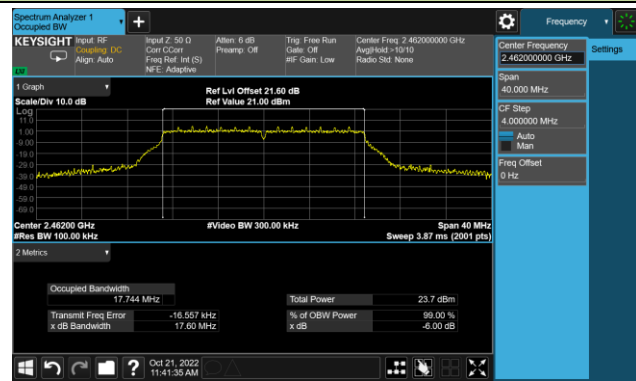

802.11n-HT40 6dB Bandwidth

Channel 03 (2422MHz)

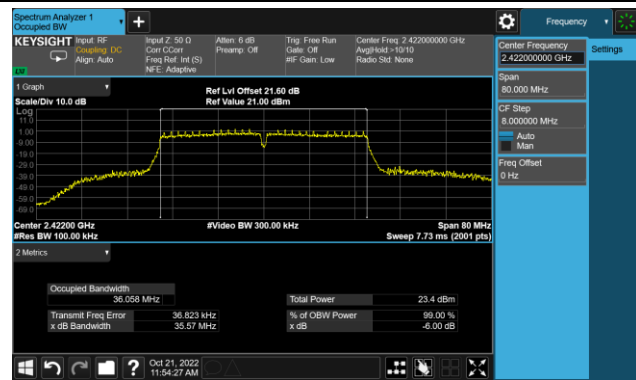

Channel 06 (2437MHz)

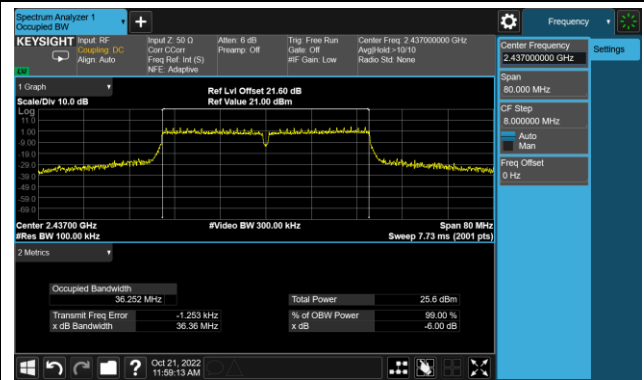

Channel 09 (2452MHz)

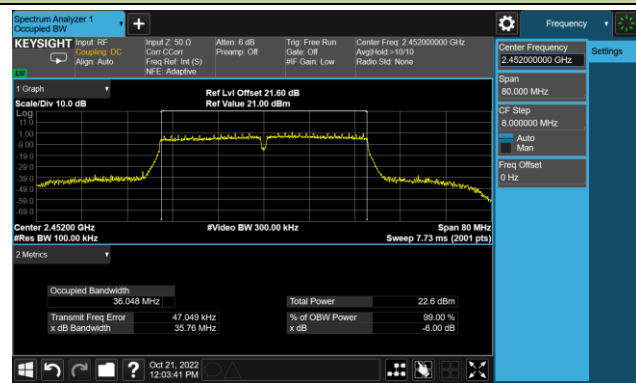

802.11ax-HE20 6dB Bandwidth

Channel 01 (2412MHz)

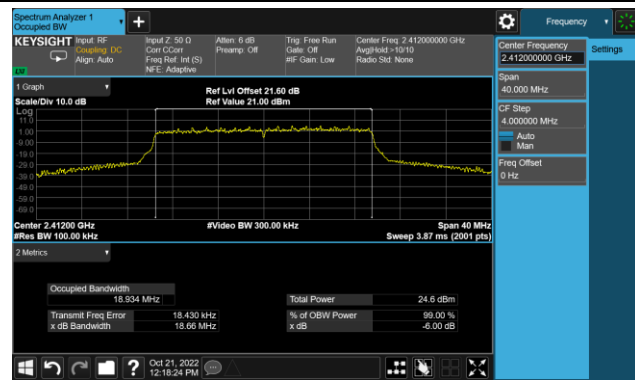

Channel 06 (2437MHz)

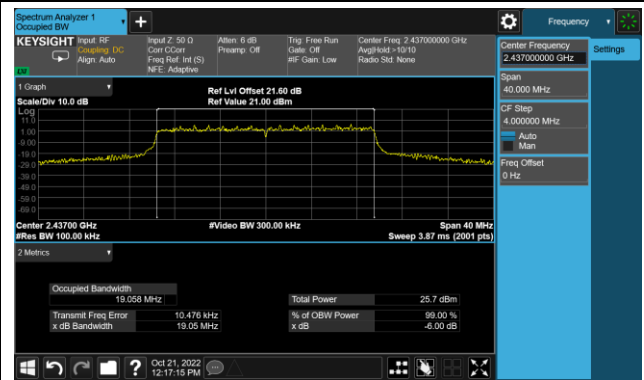

Channel 11 (2462MHz)

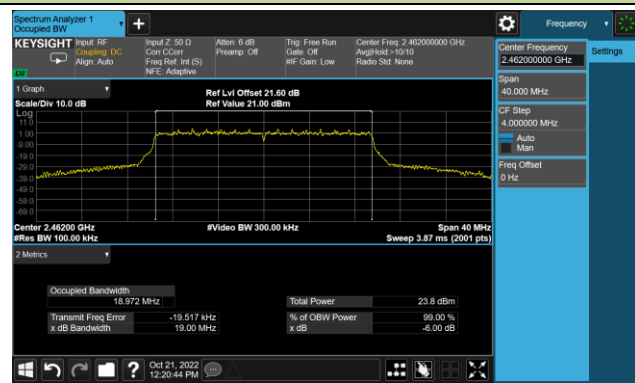

802.11ax-HE40 6dB Bandwidth

Channel 03 (2422MHz)

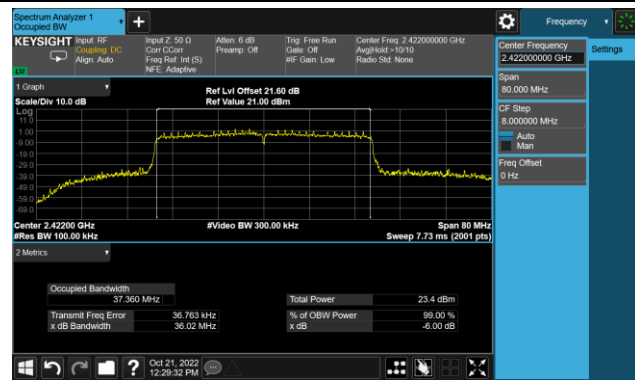

Channel 06 (2437MHz)

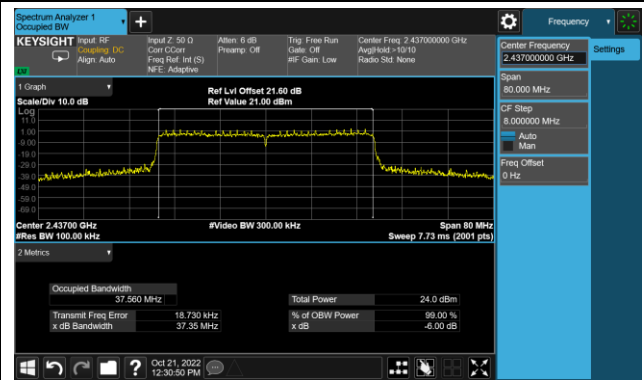

Channel 09 (2452MHz)

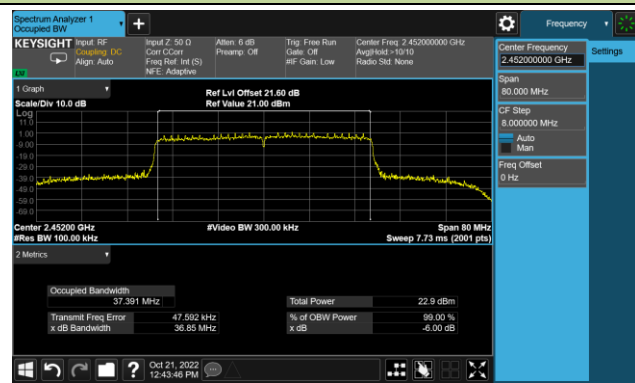

Test Site	WZ-SR5	Test Engineer	Lynn Yang
Test Date	2022-10-28	Test Mode	Radio 1

Test Mode	Data Rate / MCS	Channel No.	Frequency (MHz)	6dB Bandwidth (MHz)	Limit (MHz)
11b	1Mbps	01	2412	7.061	≥ 0.5
11b	1Mbps	06	2437	7.097	≥ 0.5
11b	1Mbps	11	2462	7.086	≥ 0.5
11g	6Mbps	01	2412	16.12	≥ 0.5
11g	6Mbps	06	2437	16.45	≥ 0.5
11g	6Mbps	11	2462	16.41	≥ 0.5
11n-HT20	MCS0	01	2412	17.37	≥ 0.5
11n-HT20	MCS0	06	2437	17.68	≥ 0.5
11n-HT20	MCS0	11	2462	17.64	≥ 0.5
11n-HT40	MCS0	03	2422	35.73	≥ 0.5
11n-HT40	MCS0	06	2437	36.32	≥ 0.5
11n-HT40	MCS0	09	2452	35.74	≥ 0.5
11ax-HE20	MCS0	01	2412	18.30	≥ 0.5
11ax-HE20	MCS0	06	2437	19.03	≥ 0.5
11ax-HE20	MCS0	11	2462	19.00	≥ 0.5
11ax-HE40	MCS0	03	2422	36.21	≥ 0.5
11ax-HE40	MCS0	06	2437	37.66	≥ 0.5
11ax-HE40	MCS0	09	2452	36.20	≥ 0.5

802.11b 6dB Bandwidth

Channel 01 (2412MHz)

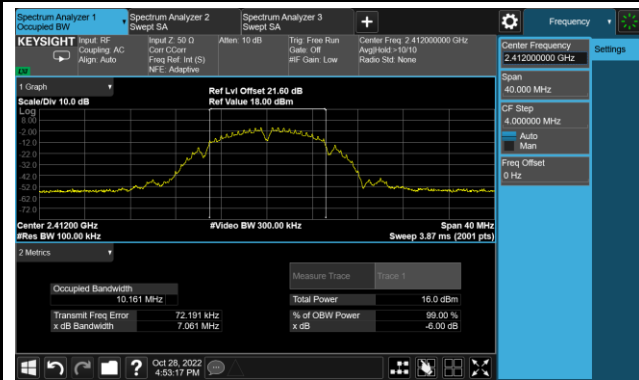

Channel 06 (2437MHz)

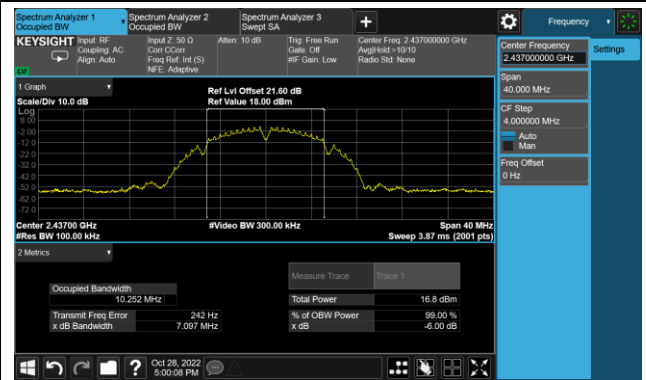

Channel 11 (2462MHz)

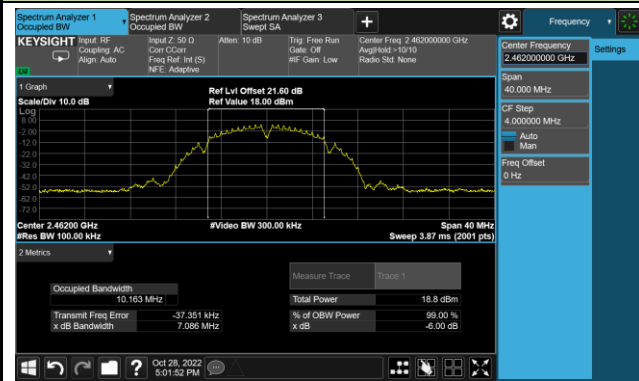

802.11g 6dB Bandwidth

Channel 01 (2412MHz)

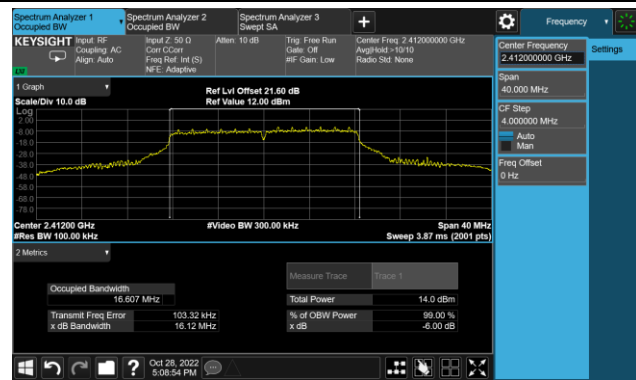

Channel 06 (2437MHz)

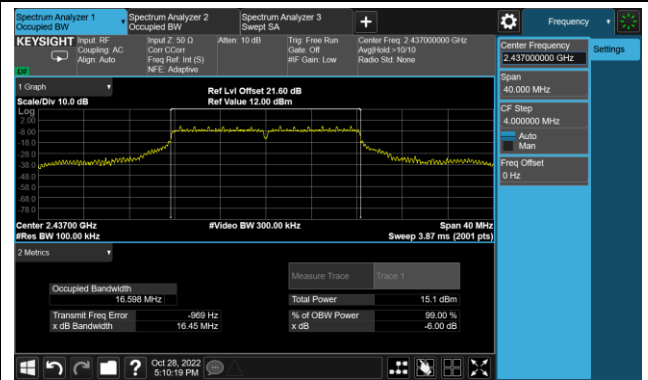

Channel 11 (2462MHz)

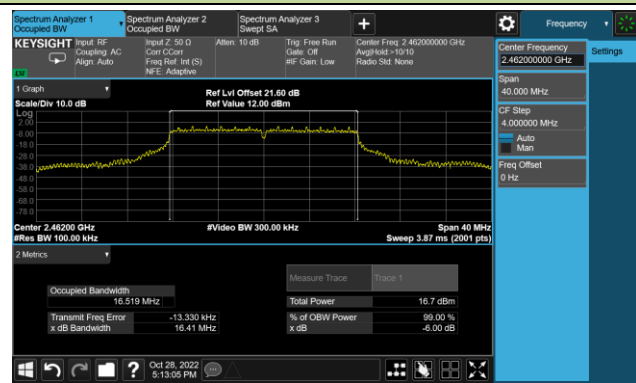

802.11n-HT20 6dB Bandwidth

Channel 01 (2412MHz)

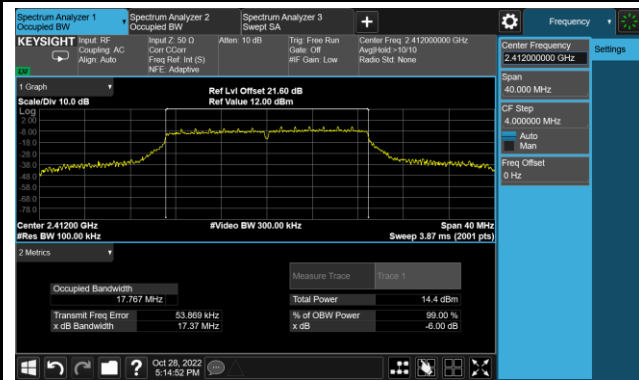

Channel 06 (2437MHz)

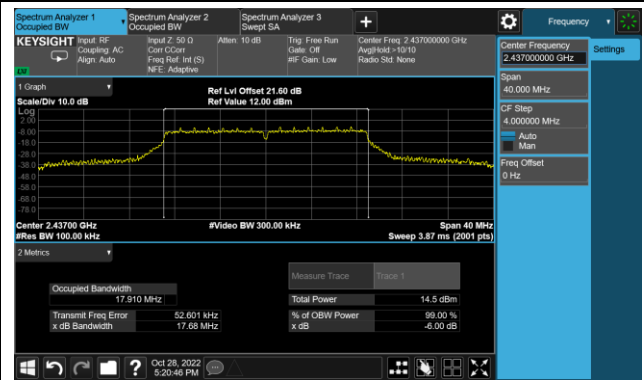

Channel 11 (2462MHz)

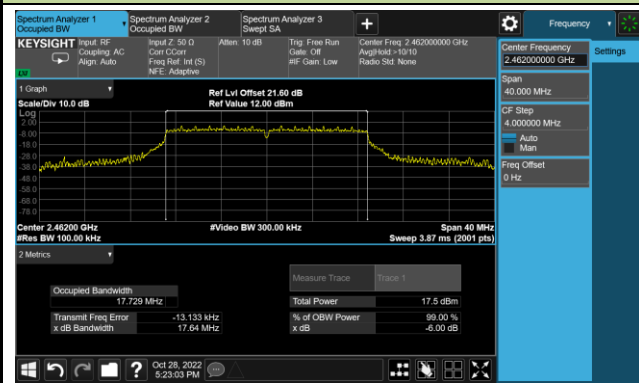

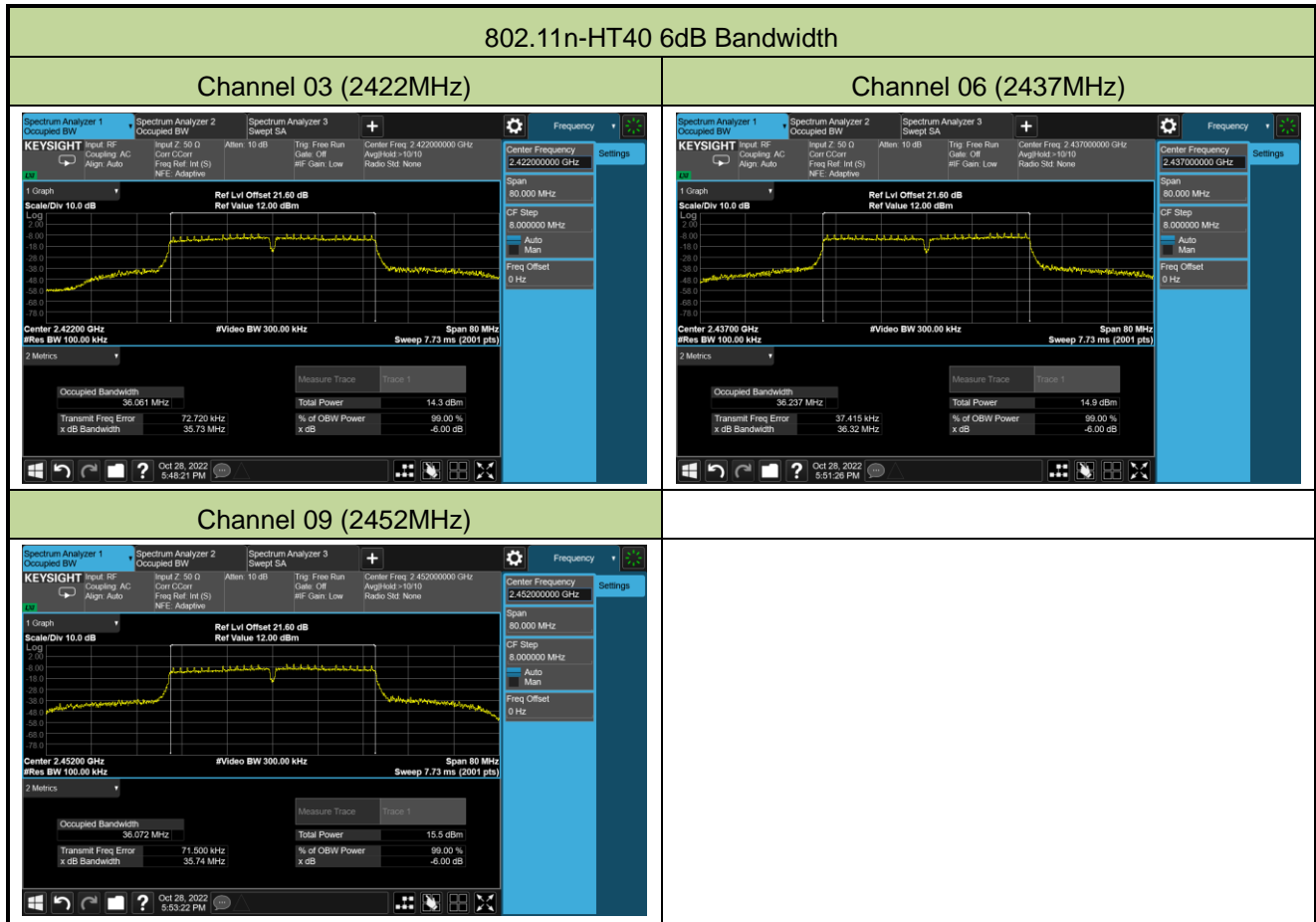

802.11ax-HE20 6dB Bandwidth

Channel 01 (2412MHz)

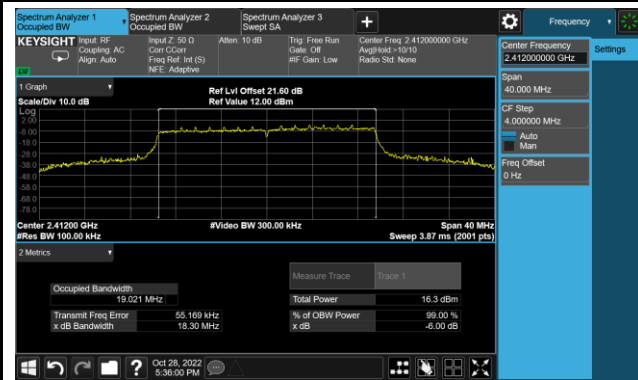

Channel 06 (2437MHz)

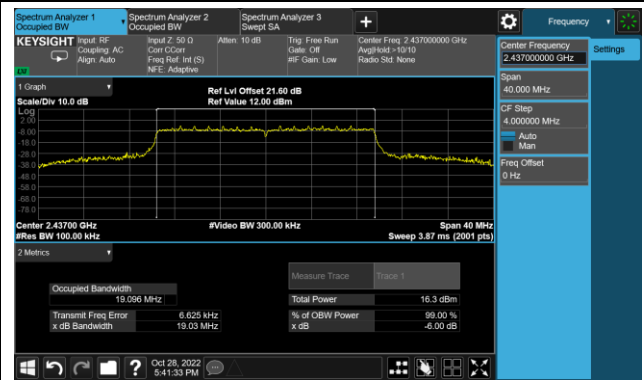

Channel 11 (2462MHz)

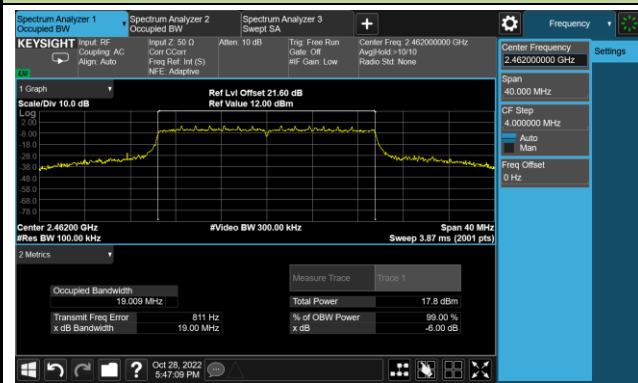

802.11ax-HE40 6dB Bandwidth

Channel 03 (2422MHz)

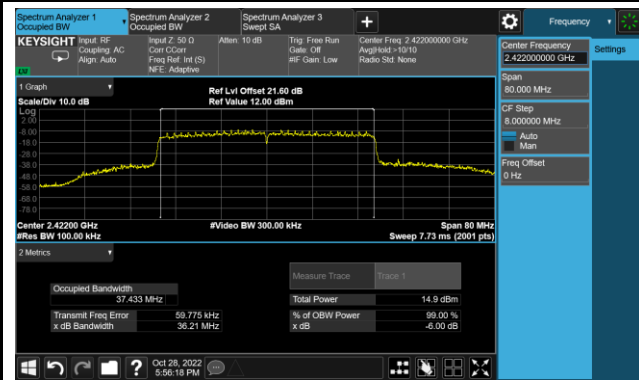

Channel 06 (2437MHz)

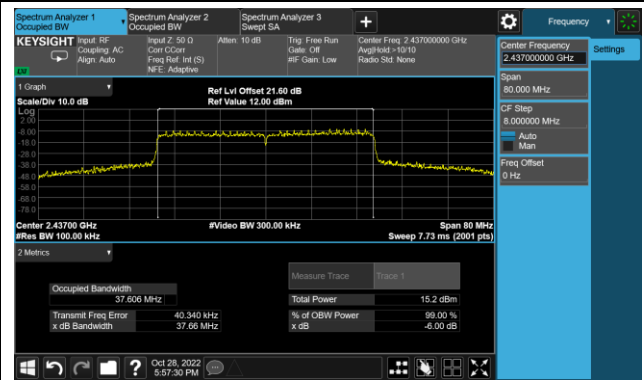

Channel 09 (2452MHz)

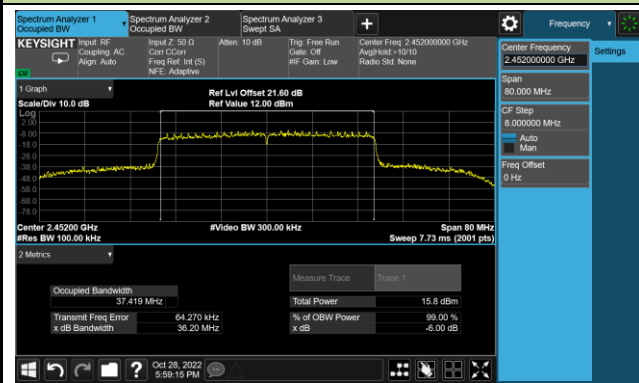

A.3 Output Power Test Result

Test Site	WZ-SR5	Test Engineer	Lynn Yang
Test Date	2022-12-01	Test Mode	Radio 0 – Filter 1#

Test Mode	Data Rate/ MCS	Channel No.	Freq. (MHz)	Average Power(dBm)		Total Power (dBm)	Limit (dBm)
				Ant 0	Ant 1		
11b	1Mbps	01	2412	17.98	17.75	20.88	≤ 30.00
11b	1Mbps	06	2437	18.25	18.06	21.17	≤ 30.00
11b	1Mbps	11	2462	18.35	18.45	21.41	≤ 30.00
11g	6Mbps	01	2412	17.40	16.92	20.18	≤ 30.00
11g	6Mbps	06	2437	18.40	18.24	21.33	≤ 30.00
11g	6Mbps	11	2462	16.47	16.41	19.45	≤ 30.00
11n-HT20	MCS0	01	2412	17.16	16.77	19.98	≤ 30.00
11n-HT20	MCS0	06	2437	18.42	18.07	21.26	≤ 30.00
11n-HT20	MCS0	11	2462	16.63	16.45	19.55	≤ 30.00
11n-HT40	MCS0	03	2422	16.59	16.62	19.62	≤ 30.00
11n-HT40	MCS0	06	2437	17.96	18.12	21.05	≤ 30.00
11n-HT40	MCS0	09	2452	15.27	15.34	18.32	≤ 30.00
11ax-HT20	MCS0	01	2412	17.19	16.83	20.02	≤ 30.00
11ax-HT20	MCS0	06	2437	18.46	18.18	21.33	≤ 30.00
11ax-HT20	MCS0	11	2462	16.51	16.34	19.44	≤ 30.00
11ax-HT40	MCS0	03	2422	16.20	16.29	19.26	≤ 30.00
11ax-HT40	MCS0	06	2437	17.03	16.91	19.98	≤ 30.00
11ax-HT40	MCS0	09	2452	15.57	15.70	18.65	≤ 30.00

Test Site	WZ-SR5	Test Engineer	Lynn Yang
Test Date	2022-12-01	Test Mode	Radio 0 – Filter 2#

Test Mode	Data Rate/ MCS	Channel No.	Freq. (MHz)	Average Power(dBm)		Total Power (dBm)	Limit (dBm)
				Ant 0	Ant 1		
11b	1Mbps	01	2412	17.93	17.71	20.83	≤ 30.00
11b	1Mbps	06	2437	18.20	17.84	21.03	≤ 30.00
11g	6Mbps	01	2412	17.39	16.87	20.15	≤ 30.00
11g	6Mbps	06	2437	18.33	17.86	21.11	≤ 30.00
11n-HT20	MCS0	01	2412	16.87	16.66	19.78	≤ 30.00
11n-HT20	MCS0	06	2437	18.33	17.96	21.16	≤ 30.00
11n-HT40	MCS0	03	2422	16.56	16.58	19.58	≤ 30.00
11ax-HT20	MCS0	01	2412	16.88	16.72	19.81	≤ 30.00
11ax-HT20	MCS0	06	2437	18.43	18.09	21.27	≤ 30.00
11ax-HT40	MCS0	03	2422	15.82	16.16	19.00	≤ 30.00

Test Site	WZ-SR5	Test Engineer	Lynn Yang
Test Date	2022-12-01	Test Mode	Radio 0 – Filter 3#

Test Mode	Data Rate/ MCS	Channel No.	Freq. (MHz)	Average Power(dBm)		Total Power (dBm)	Limit (dBm)
				Ant 0	Ant 1		
11b	1Mbps	11	2462	18.27	18.41	21.35	≤ 30.00
11g	6Mbps	11	2462	16.44	16.38	19.42	≤ 30.00
11n-HT20	MCS0	11	2462	16.48	16.36	19.43	≤ 30.00
11ax-HT20	MCS0	11	2462	16.31	16.24	19.29	≤ 30.00

Test Site	WZ-SR5	Test Engineer	Lynn Yang
Test Date	2022-12-01	Test Mode	Radio 1 – Filter 1#

Test Mode	Data Rate/ MCS	Channel No.	Freq. (MHz)	Average Power(dBm)		Total Power (dBm)	Limit (dBm)
				Ant 0	Ant 1		
11b	1Mbps	01	2412	17.88	17.71	20.81	≤ 30.00
11b	1Mbps	06	2437	17.88	18.31	21.11	≤ 30.00
11b	1Mbps	11	2462	17.75	18.31	21.05	≤ 30.00
11g	6Mbps	01	2412	17.36	17.07	20.23	≤ 30.00
11g	6Mbps	06	2437	18.19	18.25	21.23	≤ 30.00
11g	6Mbps	11	2462	16.57	16.39	19.49	≤ 30.00
11n-HT20	MCS0	01	2412	16.86	16.82	19.85	≤ 30.00
11n-HT20	MCS0	06	2437	18.43	18.36	21.41	≤ 30.00
11n-HT20	MCS0	11	2462	16.22	16.44	19.34	≤ 30.00
11n-HT40	MCS0	03	2422	16.27	15.89	19.09	≤ 30.00
11n-HT40	MCS0	06	2437	17.28	17.10	20.20	≤ 30.00
11n-HT40	MCS0	09	2452	16.32	15.78	19.07	≤ 30.00
11ax-HT20	MCS0	01	2412	16.45	16.40	19.44	≤ 30.00
11ax-HT20	MCS0	06	2437	18.44	18.45	21.46	≤ 30.00
11ax-HT20	MCS0	11	2462	16.28	16.30	19.30	≤ 30.00
11ax-HT40	MCS0	03	2422	16.43	15.96	19.21	≤ 30.00
11ax-HT40	MCS0	06	2437	17.35	16.96	20.17	≤ 30.00
11ax-HT40	MCS0	09	2452	15.90	15.55	18.74	≤ 30.00

Test Site	WZ-SR5	Test Engineer	Lynn Yang
Test Date	2022-12-01	Test Mode	Radio 1 – Filter 2#

Test Mode	Data Rate/ MCS	Channel No.	Freq. (MHz)	Average Power(dBm)		Total Power (dBm)	Limit (dBm)
				Ant 0	Ant 1		
11b	1Mbps	01	2412	17.27	17.70	20.50	≤ 30.00
11b	1Mbps	06	2437	17.87	18.29	21.10	≤ 30.00
11g	6Mbps	01	2412	17.05	16.97	20.02	≤ 30.00
11g	6Mbps	06	2437	18.17	18.00	21.10	≤ 30.00
11n-HT20	MCS0	01	2412	16.40	16.37	19.40	≤ 30.00
11n-HT20	MCS0	06	2437	18.34	18.16	21.26	≤ 30.00
11n-HT40	MCS0	03	2422	15.81	15.49	18.66	≤ 30.00
11ax-HT20	MCS0	01	2412	16.32	15.99	19.17	≤ 30.00
11ax-HT20	MCS0	06	2437	18.43	18.25	21.35	≤ 30.00
11ax-HT40	MCS0	03	2422	15.29	15.13	18.22	≤ 30.00

Test Site	WZ-SR5	Test Engineer	Lynn Yang
Test Date	2022-12-01	Test Mode	Radio 1 – Filter 3#

Test Mode	Data Rate/ MCS	Channel No.	Freq. (MHz)	Average Power(dBm)		Total Power (dBm)	Limit (dBm)
				Ant 0	Ant 1		
11b	1Mbps	11	2462	17.67	18.28	21.00	≤ 30.00
11g	6Mbps	11	2462	16.31	16.35	19.34	≤ 30.00
11n-HT20	MCS0	11	2462	16.16	16.23	19.21	≤ 30.00
11ax-HT20	MCS0	11	2462	16.16	16.17	19.18	≤ 30.00

A.4 Power Spectral Density Test Result

Test Site	WZ-SR5	Test Engineer	Lynn Yang
Test Date	2022-10-27~2022-10-28	Test Mode	Radio 0

Test Mode	Data Rate/ MCS	Channel No.	Freq. (MHz)	PSD (dBm/10kHz)		Total PSD (dBm/10kHz)	Limit (dBm/3kHz)	Result
				Ant 0	Ant 1			
11b	1Mbps	01	2412	-7.298	-7.488	-4.12	≤ 8.00	Pass
11b	1Mbps	06	2437	-7.289	-7.633	-4.19	≤ 8.00	Pass
11b	1Mbps	11	2462	-6.988	-7.235	-3.84	≤ 8.00	Pass
11g	6Mbps	01	2412	-10.676	-11.016	-7.57	≤ 8.00	Pass
11g	6Mbps	06	2437	-9.676	-9.882	-6.50	≤ 8.00	Pass
11g	6Mbps	11	2462	-11.627	-11.806	-8.44	≤ 8.00	Pass
11n-HT20	MCS0	01	2412	-10.235	-10.937	-7.33	≤ 8.00	Pass
11n-HT20	MCS0	06	2437	-9.660	-10.194	-6.67	≤ 8.00	Pass
11n-HT20	MCS0	11	2462	-11.567	-12.051	-8.56	≤ 8.00	Pass
11n-HT40	MCS0	03	2422	-13.804	-13.659	-10.25	≤ 8.00	Pass
11n-HT40	MCS0	06	2437	-12.324	-12.036	-8.70	≤ 8.00	Pass
11n-HT40	MCS0	09	2452	-15.186	-14.845	-11.53	≤ 8.00	Pass
11ax-HT20	MCS0	01	2412	-12.001	-12.388	-9.08	≤ 8.00	Pass
11ax-HT20	MCS0	06	2437	-10.732	-10.988	-7.75	≤ 8.00	Pass
11ax-HT20	MCS0	11	2462	-12.687	-12.775	-9.62	≤ 8.00	Pass
11ax-HT40	MCS0	03	2422	-14.783	-14.737	-11.53	≤ 8.00	Pass
11ax-HT40	MCS0	06	2437	-14.603	-14.713	-11.42	≤ 8.00	Pass
11ax-HT40	MCS0	09	2452	-15.936	-14.911	-12.16	≤ 8.00	Pass

802.11b - PSD – Ant 0

Channel 01 (2412MHz)



Channel 06 (2437MHz)

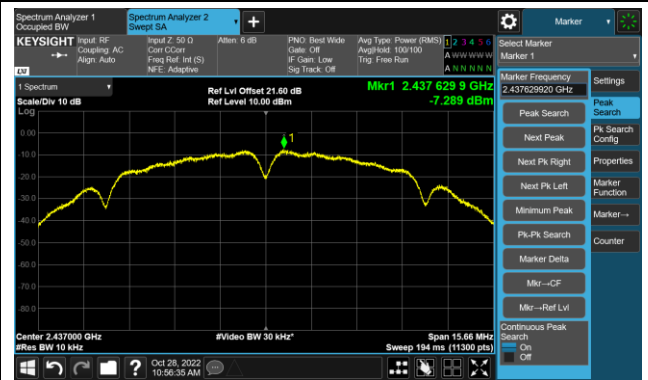

Channel 11 (2462MHz)



802.11g - PSD – Ant 0

Channel 01 (2412MHz)

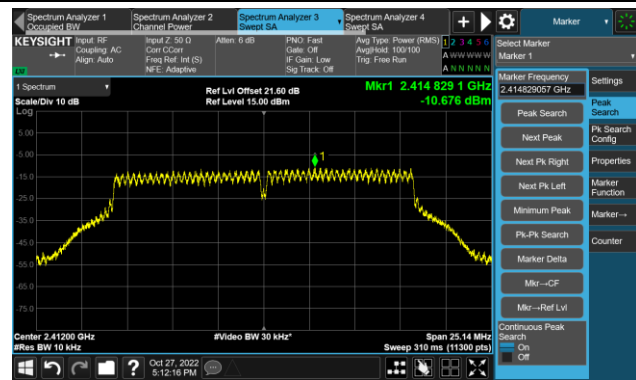

Channel 06 (2437MHz)



Channel 11 (2462MHz)

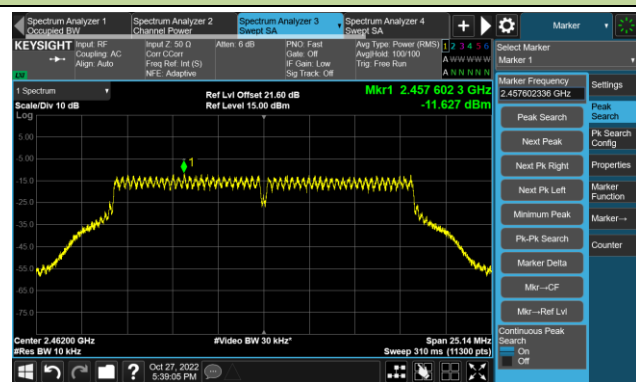

802.11n-HT20 - PSD – Ant 0

Channel 01 (2412MHz)

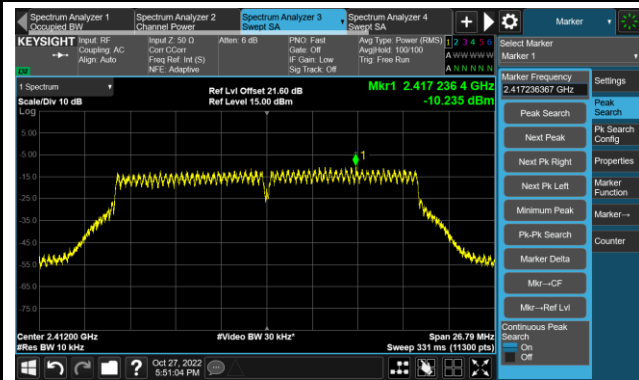

Channel 06 (2437MHz)

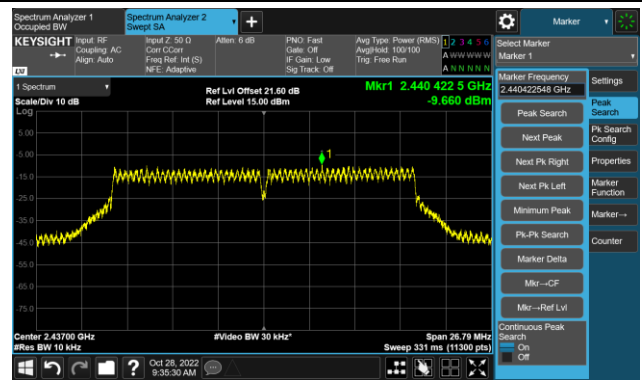

Channel 11 (2462MHz)

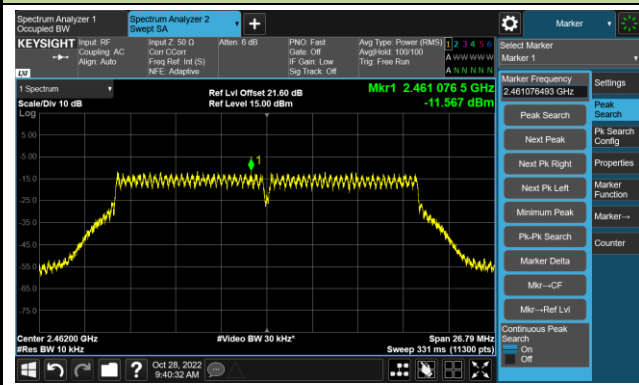

802.11n-HT40 - PSD – Ant 0

Channel 03 (2422MHz)

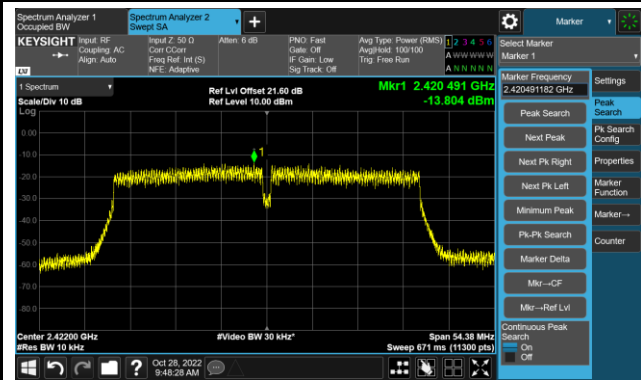

Channel 06 (2437MHz)

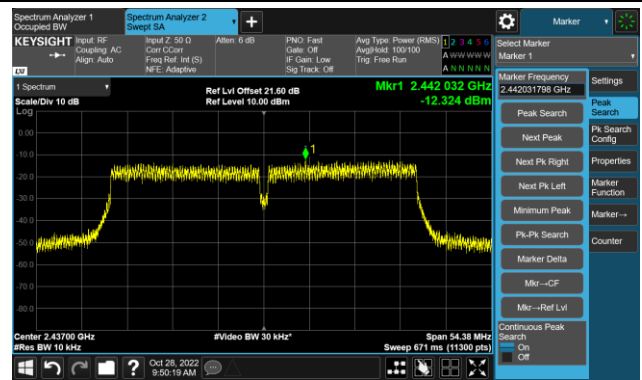

Channel 09 (2452MHz)

