



RF MEASUREMENT REPORT

FCC ID: Q9DAPIN0655
Applicant: Hewlett Packard Enterprise Company
Product: ACCESS POINT
Model No.: APIN0655
Brand Name:  
FCC Classification: Unlicensed National Information Infrastructure (NII)
FCC Rule Part(s): Part 15 Subpart E (Section 15.407)
Test Date: October 15, 2021 ~ March 15, 2022

Reviewed By:

Jame Yuan

Approved By:

Robin Wu



The test results relate only to the samples tested.

This equipment has been shown to be capable of compliance with the applicable technical standards as indicated in the measurement report and was tested in accordance with the measurement procedures specified in KDB789033 and KDB 291074. Test results reported herein relate only to the item(s) tested.

The test report shall not be reproduced except in full without the written approval of MRT Technology (Suzhou) Co., Ltd.

Revision History

Report No.	Version	Description	Issue Date	Note
2109RSU026-U1	Rev. 01	Initial Report	03-16-2022	Valid

CONTENTS

Description	Page
1. General Information	6
1.1. Applicant	6
1.2. Manufacturer	6
1.3. Testing Facility	6
1.4. Product Information.....	7
1.5. Radio Specification	7
1.6. Working Frequencies	8
1.7. Antenna Details.....	9
2. Test Configuration	10
2.1. Test Mode.....	10
2.2. Test System Connection Diagram.....	11
2.3. Applied Standards.....	11
2.4. Test Environment Condition	11
3. Antenna Requirements	12
4. Measuring Instrument	13
5. Measurement Uncertainty.....	14
6. Test Result.....	15
6.1. Summary.....	15
6.2. 26dB & 99% Bandwidth Measurement	16
6.2.1. Test Limit	16
6.2.2. Test Procedure.....	16
6.2.3. Test Setting	16
6.2.4. Test Setup	17
6.2.5. Test Result	17
6.3. 6dB Bandwidth Measurement.....	18
6.3.1. Test Limit	18
6.3.2. Test Procedure.....	18
6.3.3. Test Setting	18
6.3.4. Test Setup	18
6.3.5. Test Result	18
6.4. Output Power Measurement	19
6.4.1. Test Limit	19
6.4.2. Test Procedure.....	19
6.4.3. Test Setting	19
6.4.4. Test Setup	19

6.4.5.	Test Result	19
6.5.	Power Spectral Density Measurement	20
6.5.1.	Test Limit	20
6.5.2.	Test Procedure	20
6.5.3.	Test Setting	20
6.5.4.	Test Setup	21
6.5.5.	Test Result	21
6.6.	Frequency Stability Measurement	22
6.6.1.	Test Limit	22
6.6.2.	Test Procedure	22
6.6.3.	Test Setup	23
6.6.4.	Test Result	23
6.7.	Radiated Spurious Emission Measurement.....	24
6.7.1.	Test Limit	24
6.7.2.	Test Procedure	24
6.7.3.	Test Setting	24
6.7.4.	Test Setup	26
6.7.5.	Test Result	26
6.8.	Radiated Restricted Band Edge Measurement	27
6.8.1.	Test Limit	27
6.8.2.	Test Procedure	28
6.8.3.	Test Setting	28
6.8.4.	Test Setup	29
6.8.5.	Test Result	29
6.9.	AC Conducted Emissions Measurement	30
6.9.1.	Test Limit	30
6.9.2.	Test Setup	30
6.9.3.	Test Result	30
Appendix A – Test Result		31
A.1	Duty Cycle Test Result	31
A.2	26dB & 99% Bandwidth Test Result	33
A.3	6dB Bandwidth Test Result	39
A.4	Output Power Test Result	45
A.5	Power Spectral Density Test Result	47
A.6	Frequency Stability Test Result.....	69
A.7	Radiated Spurious Emission Test Result.....	70
A.8	Radiated Restricted Band Edge Test Result.....	120
A.9	AC Conducted Emissions Test Result	154

Appendix B – Test Setup Photograph156
Appendix C – EUT Photograph157

1.4. Product Information

Product Name	ACCESS POINT
Model No.	APIN0655
Serial No.	CNMJKZ201Z
Software Version	Spf11.4cs
Wi-Fi Specification	802.11a/b/g/n/ac/ax
Bluetooth Specification	v5.0 single mode, BLE only
Zigbee Specification	802.15.4
GNSS Specification	GPS, GLONASS, Galileo
Operating Temperature	0 ~ 50 °C
Antenna Information	Refer to Section 1.7
Power Type	AC Adapter or PoE input
Operating Environment	Indoor Use
Remark: The information of EUT was provided by the manufacturer, and the accuracy of the information shall be the responsibility of the manufacturer.	

1.5. Radio Specification

Frequency Range	For 802.11a/n-HT20/ac-VHT20/ax-HE20: 5845MHz, 5865MHz, 5885MHz For 802.11n-HT40/ac-VHT40/ax-HE40: 5835MHz, 5875MHz For 802.11ac-VHT80/ax-HE80: 5855MHz For 802.11ac-VHT80+80/ax-HE80+80: 5775 + 5855MHz
Type of Modulation	802.11a/n/ac: OFDM 802.11ax: OFDMA
Data Rate	802.11a: 6/9/12/18/24/36/48/54Mbps 802.11n: up to 600Mbps 802.11ac: up to 1733.3Mbps 802.11ax: up to 2402Mbps

Note: For other features of this EUT, test report will be issued separately.

1.6. Working Frequencies

802.11a/n-HT20/ac-VHT20/ax-HE20

Channel	Frequency	Channel	Frequency	Channel	Frequency
169	5845 MHz	173	5865 MHz	177	5885 MHz

802.11n-HT40/ac-VHT40/ax-HE40

Channel	Frequency	Channel	Frequency	Channel	Frequency
167	5835 MHz	175	5875 MHz	--	--

802.11ac-VHT80/ax-HE80

Channel	Frequency	Channel	Frequency	Channel	Frequency
171	5855 MHz	--	--	--	--

802.11ac-VHT80+80/ax-HE80+80

Channel	Frequency	Channel	Frequency	Channel	Frequency
155 + 171	5775 + 5855 MHz	--	--	--	--

1.7. Antenna Details

Antenna Type	Frequency Band (GHz)	Max Peak Gain (dBi)	CDD Directional Gain (dBi)		BF Directional Gain (dBi)
			For Power	For PSD	
Wi-Fi Internal Antenna (4*4 MIMO)					
PIFA	2.4 ~ 2.5	3.26	3.26	6.23	6.23
	5.15 ~ 5.9	2.88	2.88	5.60	5.60
	5.9 ~ 7.2	3.97	3.97	6.97	6.97
Bluetooth / ZigBee Internal Antenna					
PIFA	2.4 ~ 2.5	3.60			

Note:

- The EUT supports Cyclic Delay Diversity (CDD) mode, and CDD signals are correlated.
- The EUT also supports Beam Forming mode, and the Beam Forming support 802.11n/ac/ax, not include 802.11a/b/g.
- For beamforming operation, Aruba OS automatically backs power down based on a $10\log(N)$ factor based on CDD power.
- All Wi-Fi antennas have cross polarized design, the detail information and calculation method refer to antenna specification.
- 5GHz sample calculations:
 - Maximum uncorrelated gain: $2.88\text{dBi} = 10\log(((10^{(G0/10)}) + (10^{(G1/10)}) + (10^{(G2/10)}) + (10^{(G3/10)}))/4) = 10\log(((10^{(5.34/10)}) + (10^{(0.59/10)}) + (10^{(-0.7/10)}) + (10^{(3.96/10)}))/4)$
 - 5900MHz: phi 25/theta 45
 - Maximum correlated gain: $5.60\text{dBi} = 10\log((((10^{(5G_V/10)}) + (10^{(5G_H/10)}))/2) = 10\log((((10^{(4.77/10)}) + (10^{(6.29/10)}))/2)$
 - 5900MHz: phi 25/theta 45
 - $5G_V = \text{correlated gain of vertical antenna pairs} = 4.77\text{dBi} = 10\log(((10^{(G2/20)}) + (10^{(G3/20)}))^2/2) = 10\log(((10^{(-0.7/20)}) + (10^{(3.69/20)}))^2/2)$
 - $5G_H = \text{correlated gain of vertical antenna pairs} = 6.29\text{dBi} = 10\log(((10^{(G0/20)}) + (10^{(G1/20)}))^2/2) = 10\log(((10^{(5.34/20)}) + (10^{(0.59/20)}))^2/2)$

2. Test Configuration

2.1. Test Mode

Mode 1: Transmit by 802.11a (6Mbps)
Mode 2: Transmit by 802.11ac-VHT20 (MCS0)
Mode 3: Transmit by 802.11ac-VHT40 (MCS0)
Mode 4: Transmit by 802.11ac-VHT80 (MCS0)
Mode 5: Transmit by 802.11ac-VHT80+80 (MCS0)
Mode 6: Transmit by 802.11ax-HE20 (MCS0)
Mode 7: Transmit by 802.11ax-HE40 (MCS0)
Mode 8: Transmit by 802.11ax-HE80 (MCS0)
Mode 9: Transmit by 802.11ax-HE80+80 (MCS0)

Note: 802.11n and 802.11ac have same modulation type and same power parameter, so we only show 802.11ac test data in report.

2.2. Test System Connection Diagram

The device was tested per the guidance ANSI C63.10: 2013 was used to reference the appropriate EUT setup for radiated emissions testing and AC line conducted testing.

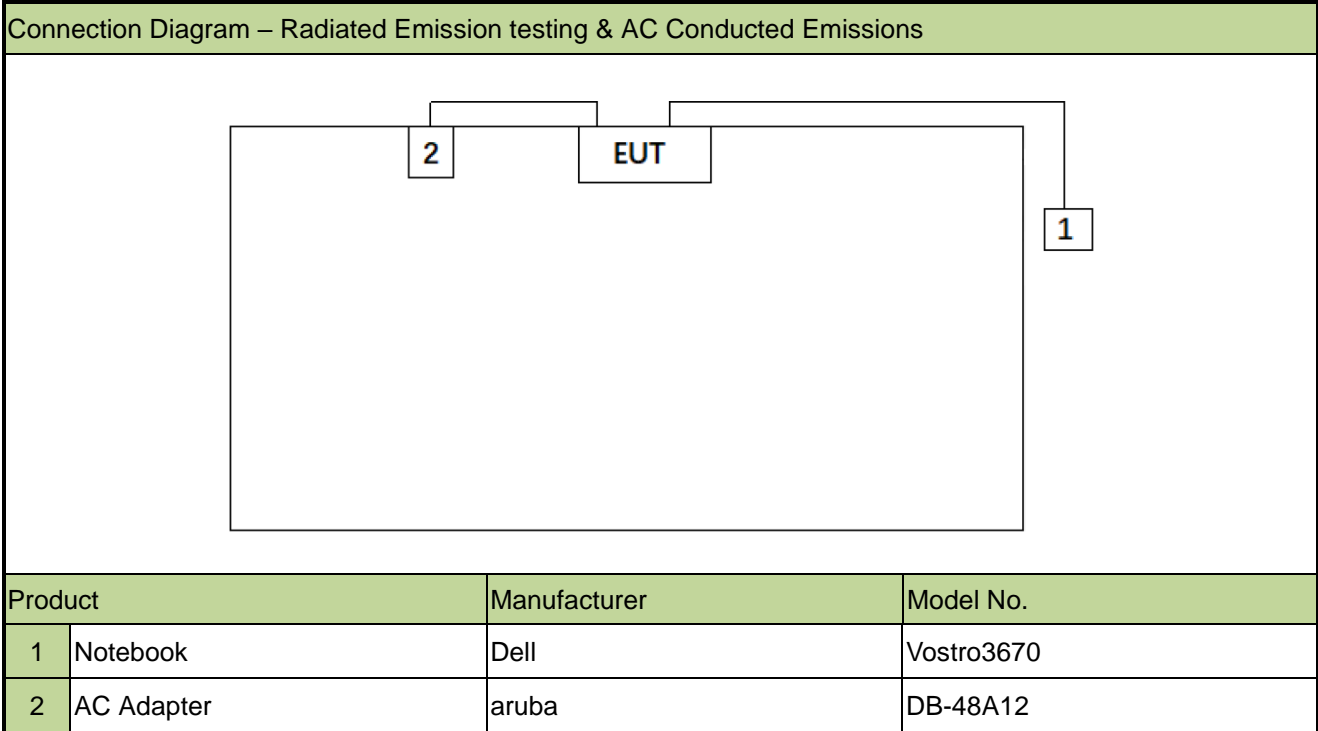

Note 1: The test utility software used during testing was “QRCT”, and the version was “4.0”.

Note 2: Detail power setting refer to operation description.

2.3. Applied Standards

According to the specifications of the manufacturer, the EUT must comply with the requirements of the following standards:

- FCC Part 15.407
- KDB 789033 D02v02r01
- KDB 291074 D02v01
- KDB 662911 D01v02r01
- ANSI C63.10-2013

2.4. Test Environment Condition

Ambient Temperature	15 ~ 35°C
Relative Humidity	20 ~ 75%RH

3. Antenna Requirements

KDB 291074 DR01: An Indoor Access point in the U-NII-4 band (5.850-5.895 GHz) and U-NII -3 & -4 span channels must use an integrated antenna

- The antenna of the device is built in and locked inside the enclosure.

4. Measuring Instrument

Instrument	Manufacturer	Model No.	Asset No.	Last Cali. Date	Cali. Due Date	Test Site
EMI Test Receiver	R&S	ESR7	MRTSUE06001	1 year	2022/12/29	WZ-AC1
Horn Antenna	Schwarzbeck	BBHA 9120D	MRTSUE06023	1 year	2022/9/16	WZ-AC1
Preamplifier	Agilent	83017A	MRTSUE06076	1 year	2022/11/12	WZ-AC1
TRILOG Antenna	Schwarzbeck	VULB 9168	MRTSUE06172	1 year	2022/8/5	WZ-AC1
Anechoic Chamber	TDK	WZ-AC1	MRTSUE06212	1 year	2022/4/29	WZ-AC1
Thermohygrometer	testo	608-H1	MRTSUE06403	1 year	2022/6/28	WZ-AC1
Signal Analyzer	Keysight	N9010B	MRTSUE06607	1 year	2022/12/29	WZ-AC1
Thermohygrometer	testo	Testo 608-H1	MRTSUE11039	1 year	2022/11/11	WZ-AC1
Horn Antenna	Schwarzbeck	BBHA 9170	MRTSUE06597	1 year	2021/12/14	WZ-AC1
				1 year	2022/12/1	WZ-AC1
Preamplifier	EMCI	EMC184045SE	MRTSUE06640	1 year	2022/1/14	WZ-AC1
				1 year	2023/1/13	WZ-AC1
Preamplifier	EMCI	EMC184045SE	MRTSUE06640	1 year	2023/1/13	WZ-AC1
Loop Antenna	Schwarzbeck	FMZB 1519	MRTSUE06025	1 year	2022/10/28	WZ-AC1
Two-Line V-Network	R&S	ENV216	MRTSUE06002	1 year	2022/6/8	WZ-SR2
CDN	Teseq	ISN PLT-A	MRTSUE06007	1 year	2022/3/1	WZ-SR2
Symmetrical Attenuator	Schwarzbeck	SYMAT 40	MRTSUE06117	1 year	2022/4/11	WZ-SR2
Shielding Room	MIX-BEP	WZ-SR2	MRTSUE06215	/	/	WZ-SR2
Thermohygrometer	testo	608-H1	MRTSUE06404	1 year	2022/6/28	WZ-SR2
Four-Line V-Network	R&S	ENV432	MRTSUE06615	1 year	2022/10/10	WZ-SR2
EMI Test Receiver	R&S	ESR3	MRTSUE06909	1 year	2022/11/1	WZ-SR2
Signal Generator	Agilent	E4438C	MRTSUE06081	1 year	2022/6/8	WZ-SR5
Signal Analyzer	Agilent	N9020A	MRTSUE06106	1 year	2022/4/13	WZ-SR5
Thermohygrometer	testo	608-H1	MRTSUE06402	1 year	2022/6/28	WZ-SR5
Shielding Room	HUAMING	WZ-SR5	MRTSUE06442	/	/	WZ-SR5
Signal Analyzer	Keysight	N9010B	MRTSUE06457	1 year	2022/6/24	WZ-SR5
USB Power Sensor	Keysight	U2021XA	MRTSUE06446	1 year	2022/6/8	WZ-SR5
Temperature Chamber	BAOYT	BYH-150CL	MRTSUE06051	1 year	2022/10/10	WZ-TR3
Thermohygrometer	testo	608-H1	MRTSUE06401	1 year	2022/6/28	WZ-TR3
Signal Analyzer	Keysight	N9010B	MRTSUE06457	1 year	2022/6/24	WZ-TR3

Software	Version	Function
EMI Software	e3	EMI Test Software

5. Measurement Uncertainty

Where relevant, the following test uncertainty levels have been estimated for tests performed on the EUT as specified in CISPR 16-4-2. This uncertainty represents an expanded uncertainty expressed at approximately the 95% confidence level using a coverage factor of $k = 2$.

AC Conducted Emission Measurement
Measurement Uncertainty for a Level of Confidence of 95% ($U=2Uc(y)$): 9kHz~150kHz: 3.74dB 150kHz~30MHz: 3.44dB
Radiated Disturbance
Measurement Uncertainty for a Level of Confidence of 95% ($U=2Uc(y)$): Horizontal: 30MHz~300MHz: 5.04dB 300MHz~1GHz: 4.95dB 1GHz~40GHz: 6.40dB Vertical: 30MHz~300MHz: 5.24dB 300MHz~1GHz: 6.03dB 1GHz~40GHz: 6.40dB
Spurious Emissions, Conducted
Measuring Uncertainty for a Level of Confidence of 95% ($U=2Uc(y)$): 0.78dB
Output Power
Measuring Uncertainty for a Level of Confidence of 95% ($U=2Uc(y)$): 1.13dB
Power Spectrum Density
Measuring Uncertainty for a Level of Confidence of 95% ($U=2Uc(y)$): 1.15dB
Occupied Bandwidth
Measuring Uncertainty for a Level of Confidence of 95% ($U=2Uc(y)$): 0.28%

6. Test Result

6.1. Summary

FCC Section(s)	Test Description	Test Condition	Verdict
15.407(a)	26dB Bandwidth	Conducted	Pass
15.407(e)	6dB Bandwidth		Pass
15.407(a)(3)(ii)	Maximum Conducted Output Power		Pass
15.407(a)(3)(ii)(12)	Peak Power Spectral Density		Pass
15.407(b)(5)	Undesirable Emissions	Radiated	Pass
15.205, 15.209 15.407(b)(5)(i), (8), (9)	General Field Strength Limits (Restricted Bands and Radiated Emission Limits)		Pass
15.207	AC Conducted Emissions 150kHz - 30MHz	Line Conducted	Pass

Remark:

- The analyzer plots shown in this section were all taken with a correction table loaded into the analyzer. The correction table was used to account for the losses of the cables and attenuators used as part of the system to connect the EUT to the analyzer at all frequencies of interest.
- Output power test was verified over all data rates of each mode (data refers to operational description), and then choose the maximum power output (low data rate) for final test of each channel.
- For radiated emission test, every axis (X, Y, Z) was also verified. The test results shown in the following sections represent the worst-case emissions.
- EUT supports one configuration only in 802.11ax full RU mode.

6.2. 26dB & 99% Bandwidth Measurement

6.2.1. Test Limit

N/A

6.2.2. Test Procedure

KDB 789033 D02v02r01- Section C.1 (26dB Bandwidth)

KDB 789033 D02v02r01- Section D (99% Bandwidth)

6.2.3. Test Setting

26dB Bandwidth

1. The analyzers' automatic bandwidth measurement capability was used to perform the 26dB bandwidth measurement. The "X" dB bandwidth parameter was set to $X = 26$. The automatic bandwidth measurement function also has the capability of simultaneously measuring the 99% occupied bandwidth. The bandwidth measurement was not influenced by any intermediated power nulls in the fundamental emission.
2. RBW = approximately 1% of the emission bandwidth.
3. VBW > RBW.
4. Detector = Peak.
5. Trace mode = max hold.

99% Bandwidth

1. Set center frequency to the nominal EUT channel center frequency.
2. Set span = 1.5 times to 5.0 times the OBW.
3. Set RBW = 1% to 5% of the OBW
4. Set VBW $\geq 3 \times$ RBW
5. Detector = Peak.
6. Use the 99% power bandwidth function of the instrument.

6.2.4. Test Setup

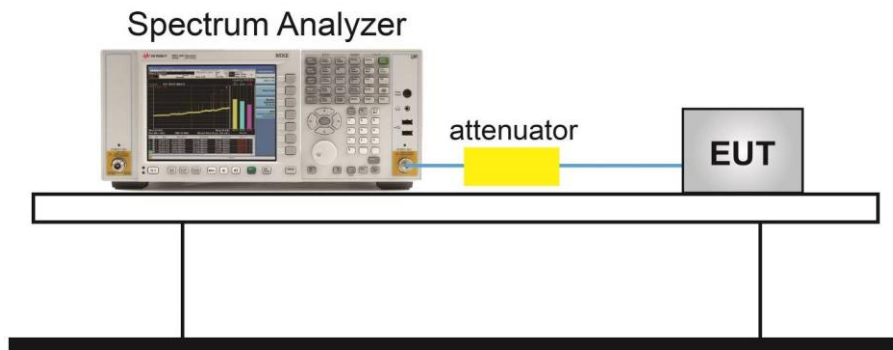

6.2.5. Test Result

Refer to Appendix A.2.

6.3. 6dB Bandwidth Measurement

6.3.1. Test Limit

The minimum 6dB bandwidth shall be at least 500 kHz.

6.3.2. Test Procedure

KDB 789033 D02v02r01- Section C.2

6.3.3. Test Setting

1. Set center frequency to the nominal EUT channel center frequency.
2. RBW = 100 kHz.
3. VBW $\geq 3 \times$ RBW.
4. Detector = Peak.
5. Trace mode = max hold.
6. Sweep = auto couple.
7. Allow the trace to stabilize.
8. Measure the maximum width of the emission that is constrained by the frequencies associated with the two outermost amplitude points (upper and lower frequencies) that are attenuated by 6 dB relative to the maximum level measured in the fundamental emission.

6.3.4. Test Setup

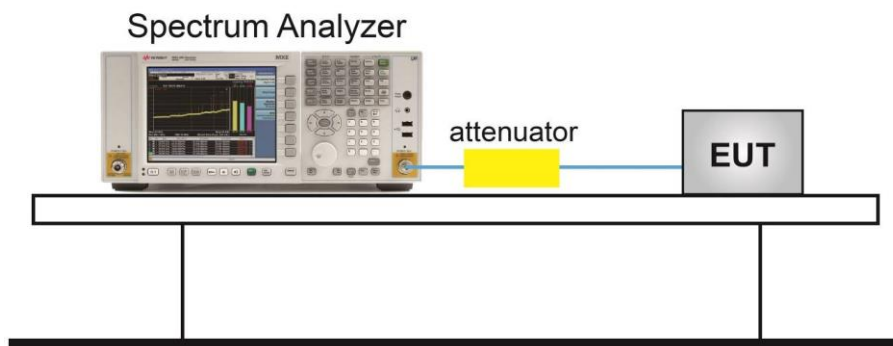

6.3.5. Test Result

Refer to Appendix A.3.

6.4. Output Power Measurement

6.4.1. Test Limit

For an indoor access point operating in the 5.850-5.895 GHz band, the maximum e.i.r.p. over the frequency band of operation must not exceed 36 dBm. Indoor access points operating on a channel that spans the 5.725-5.850 GHz and 5.850-5.895 GHz bands must not exceed an e.i.r.p. of 36 dBm.

6.4.2. Test Procedure

KDB 789033D02v02r01- Section E)3)b) Method PM-G

6.4.3. Test Setting

Average Power Measurement

Average power measurements were performed only when the EUT was transmitting at its maximum power control level using a broadband power meter with a pulse sensor. The power meter implemented triggering and gating capabilities which were set up such that power measurements were recorded only during the ON time of the transmitter.

6.4.4. Test Setup

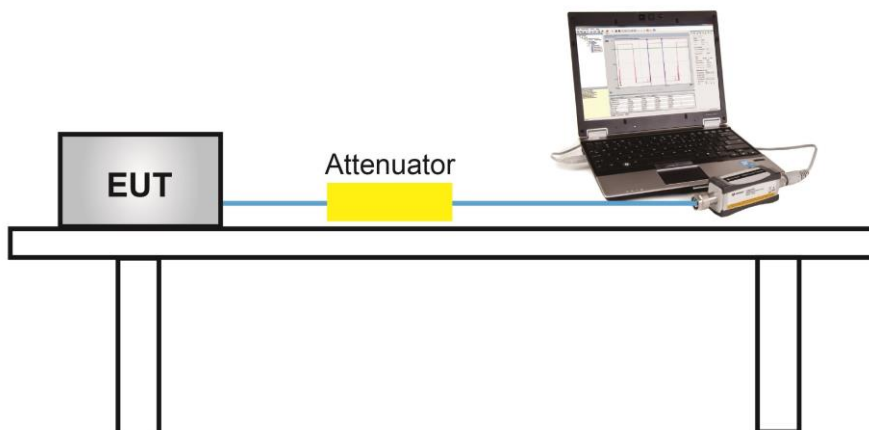

6.4.5. Test Result

Refer to Appendix A.4.

6.5. Power Spectral Density Measurement

6.5.1. Test Limit

For an indoor access point operating in the 5.850-5.895 GHz band, the maximum power spectral density must not exceed 20 dBm e.i.r.p. in any 1-megahertz band.

6.5.2. Test Procedure

KDB 789033 D02v02r01-SectionF

6.5.3. Test Setting

1. Analyzer was set to the center frequency of the UNII channel under investigation
2. Span was set to encompass the entire 26dB EBW of the signal.
3. RBW = 1MHz
4. VBW = 3 x RBW
5. Number of sweep points $\geq 2 \times (\text{span} / \text{RBW})$
6. Detector = power averaging (Average)
7. Sweep time = auto
8. Trigger = free run
9. Use the peak search function on the instrument to find the peak of the spectrum and record its value.
10. Add $10 \cdot \log(1/x)$, where x is the duty cycle, to the measured power in order to compute the average power during the actual transmission times (because the measurement represents an average over both the on and off times of the transmission). For example, add $10 \cdot \log(1/0.25) = 6$ dB if the duty cycle is 25 percent.

6.5.4. Test Setup

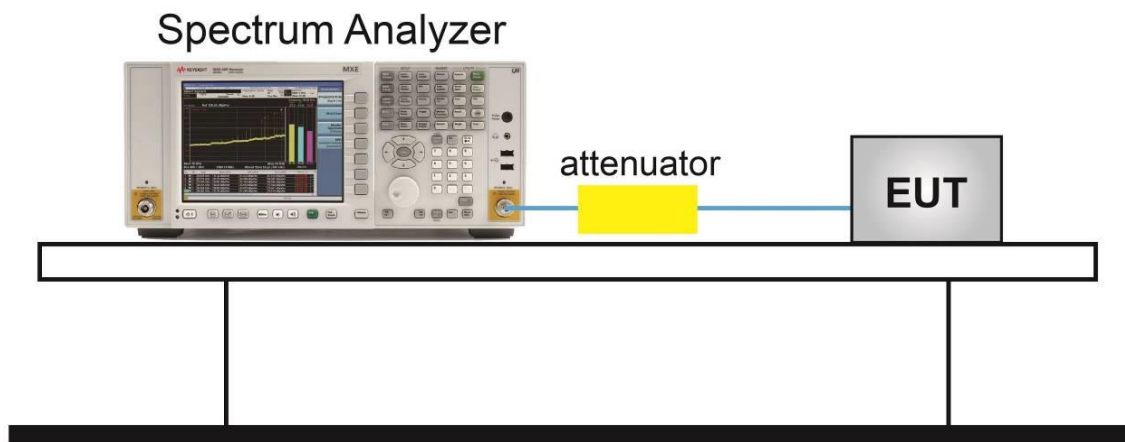

6.5.5. Test Result

Refer to Appendix A.5.

6.6. Frequency Stability Measurement

6.6.1. Test Limit

Manufactures of U-NII devices are responsible for ensuring frequency stability such that an emission is maintained within the band of operation under all conditions of normal operation as specified in the user's manual.

6.6.2. Test Procedure

Frequency Stability Under Temperature Variations:

The equipment under test was connected to an external AC or DC power supply and input rated voltage. RF output was connected to a frequency counter or spectrum analyzer via feed through attenuators. The EUT was placed inside the temperature chamber. Set the spectrum analyzer RBW low enough to obtain the desired frequency resolution and measure EUT 20°C operating frequency as reference frequency. Turn EUT off and set the chamber temperature to highest. After the temperature stabilized for approximately 30 minutes recorded the frequency. Repeat step measure with 10°C decreased per stage until the lowest temperature reached.

Frequency Stability Under Voltage Variations:

Set chamber temperature to 20°C. Use a variable AC power supply / DC power source to power the EUT and set the voltage to rated voltage. Set the spectrum analyzer RBW low enough to obtain the desired frequency resolution and recorded the frequency.

Reduce the input voltage to specify extreme voltage variation ($\pm 15\%$) and endpoint, record the maximum frequency change.

6.6.3. Test Setup

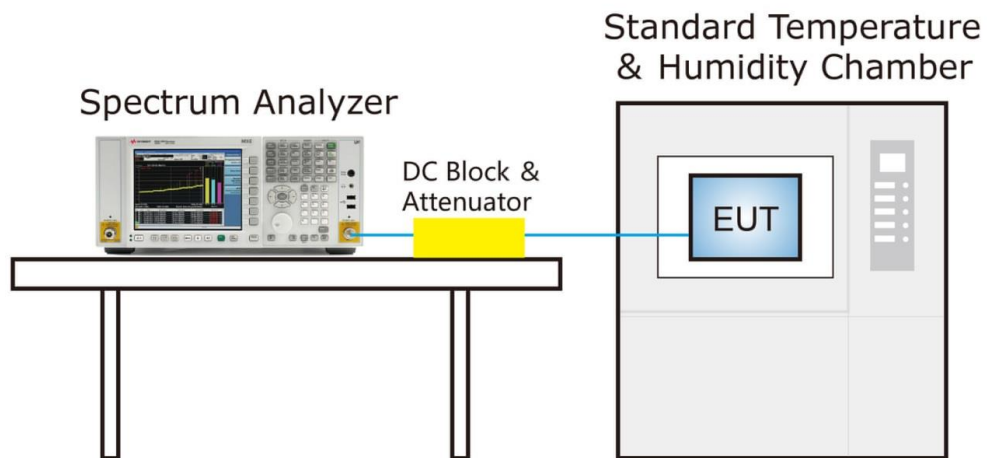

6.6.4. Test Result

Refer to Appendix A.6.

6.7. Radiated Spurious Emission Measurement

6.7.1. Test Limit

All out of band emissions appearing in a restricted band as specified in Section 15.205 of the Title 47 CFR must not exceed the limits shown in Table per Section 15.209.

FCC Part 15 Subpart C Paragraph 15.209		
Frequency	Field Strength	Measured Distance
0.009 - 0.490	2400/F (kHz)	300
0.490 - 1.705	24000/F (kHz)	30
1.705 - 30	30	30
30 - 88	100	3
88 - 216	150	3
216 - 960	200	3
Above 960	500	3

6.7.2. Test Procedure

KDB 789033 D02v02r01- Section G

6.7.3. Test Setting

Table 1 - RBW as a function of frequency

Frequency	RBW
9 ~ 150 kHz	200 ~ 300 Hz
0.15 ~ 30 MHz	9 ~ 10 kHz
30 ~ 1000 MHz	100 ~ 120 kHz
> 1000MHz	1MHz

Quasi-Peak Measurements below 1GHz

1. Analyzer center frequency was set to the frequency of the radiated spurious emission of interest
2. Span was set greater than 1MHz

3. RBW = as specified in Table 1
4. Detector = CISPR quasi-peak
5. Sweep time = auto couple
6. Trace was allowed to stabilize

Peak Measurements above 1GHz

1. Analyzer center frequency was set to the frequency of the radiated spurious emission of interest
2. RBW = 1MHz
3. VBW = 3MHz
4. Detector = peak
5. Sweep time = auto couple
6. Trace mode = max hold
7. Trace was allowed to stabilize

Average Measurements above 1GHz (Method VB)

1. Analyzer center frequency was set to the frequency of the radiated spurious emission of interest
2. RBW = 1MHz
3. VBW; If the EUT is configured to transmit with duty cycle $\geq 98\%$, set VBW = 10 Hz.

If the EUT duty cycle is $< 98\%$, set $VBW \geq 1/T$. T is the minimum transmission duration.

802.11a	VBW = 510Hz	802.11ax-HE20	VBW = 180Hz
802.11ac-VHT20	VBW = 180Hz	802.11ax-HE40	VBW = 180Hz
802.11ac-VHT40	VBW = 180Hz	802.11ax-HE80	VBW = 180Hz
802.11ac-VHT80	VBW = 180Hz		

4. Detector = Peak
5. Sweep time = auto
6. Trace mode = max hold
7. Trace was allowed to stabilize

6.7.4. Test Setup

Below 1GHz Test Setup:

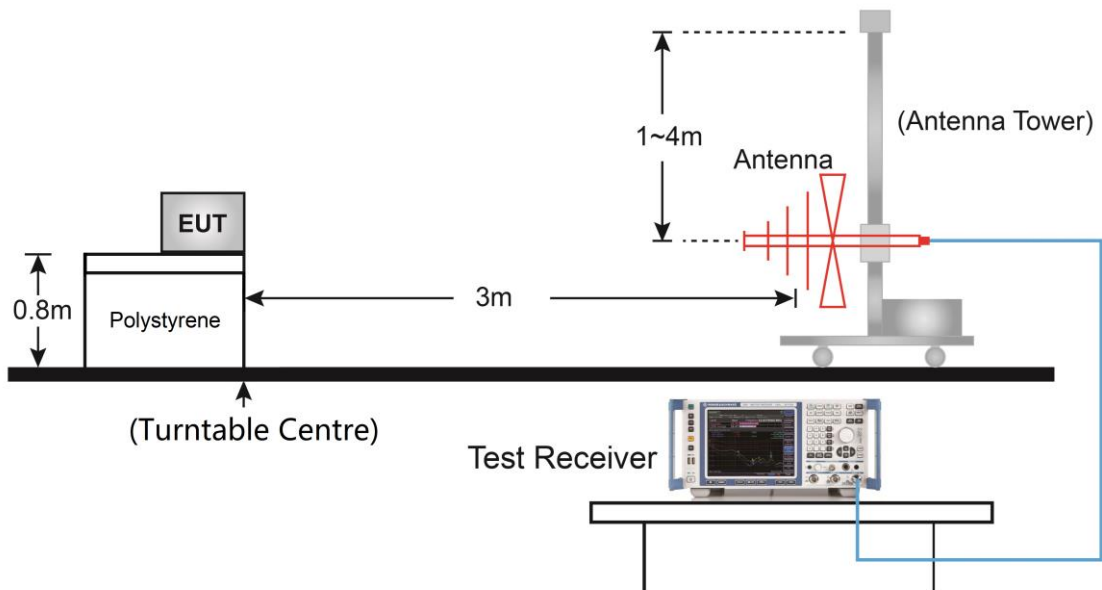

Above 1GHz Test Setup:

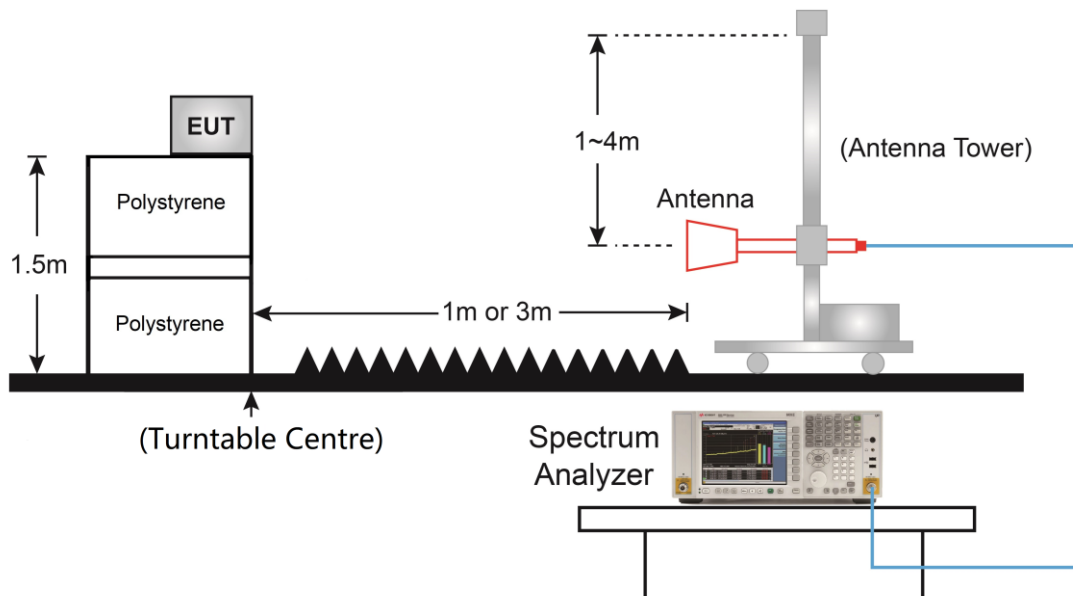

6.7.5. Test Result

Refer to Appendix A.7.

6.8. Radiated Restricted Band Edge Measurement

6.8.1. Test Limit

For 15.205 requirement:

Radiated emissions which fall in the restricted bands, as defined in Section 15.205(a) of FCC part 15, must also comply with the radiated emission limits specified in Section 15.209(a).

Frequency (MHz)	Frequency (MHz)	Frequency (MHz)	Frequency (GHz)
0.090 - 0.110	16.42 - 16.423	399.9 - 410	4.5 - 5.15
¹ 0.495 - 0.505	16.69475 - 16.69525	608 - 614	5.35 - 5.46
2.1735 - 2.1905	16.80425 - 16.80475	960 - 1240	7.25 - 7.75
4.125 - 4.128	25.5 - 25.67	1300 - 1427	8.025 - 8.5
4.17725 - 4.17775	37.5 - 38.25	1435 - 1626.5	9.0 - 9.2
4.20725 - 4.20775	73 - 74.6	1645.5 - 1646.5	9.3 - 9.5
6.215 - 6.218	74.8 - 75.2	1660 - 1710	10.6 - 12.7
6.26775 - 6.26825	108 - 121.94	1718.8 - 1722.2	13.25 - 13.4
6.31175 - 6.31225	123 - 138	2200 - 2300	14.47 - 14.5
8.291 - 8.294	149.9 - 150.05	2310 - 2390	15.35 - 16.2
8.362 - 8.366	156.52475 - 156.52525	2483.5 - 2500	17.7 - 21.4
8.37625 - 8.38675	156.7 - 156.9	2690 - 2900	22.01 - 23.12
8.41425 - 8.41475	162.0125 - 167.17	3260 - 3267	23.6 - 24.0
12.29 - 12.293	167.72 - 173.2	3332 - 3339	31.2 - 31.8
12.51975 - 12.52025	240 - 285	3345.8 - 3358	36.43 - 36.5
12.57675 - 12.57725	322 - 335.4	3600 - 4400	(²)
13.36 - 13.41	--	--	--

For 15.407(b) requirement:

For transmitters operating in the 5.725-5.85 GHz band: All emissions shall be limited to a level of -27 dBm/MHz at 75 MHz or more above or below the band edge increasing linearly to 10 dBm/MHz at 25 MHz above or below the band edge, and from 25 MHz above or below the band edge increasing linearly to a level of 15.6 dBm/MHz at 5 MHz above or below the band edge, and from 5 MHz above or below the band edge increasing linearly to a level of 27 dBm/MHz at the band edge.

For an indoor access point, all emissions at or above 5.895GHz shall not exceed an e.i.r.p. of 15 dBm/MHz and shall decrease linearly to an e.i.r.p. of -7 dBm/MHz at or above 5.925GHz.

For indoor access point or subordinate device, all emissions below 5.725 GHz shall not exceed an e.i.r.p. of -27 dBm/MHz at 5.65 GHz increasing linearly to 10 dBm/MHz at 5.7 GHz, and from 5.7 GHz increasing linearly to a level of 15.6 dBm/MHz at 5.72 GHz, and from 5.72 GHz increasing linearly to a level of 27 dBm/MHz at 5.725 GHz.

$E \text{ [dB}\mu\text{V/m]} = \text{EIRP [dBm]} + 95.2$, for example, $-27 \text{ dBm/MHz} = 68.2 \text{ dB}\mu\text{V/m}$

All out of band emissions appearing in a restricted band as specified in Section 15.205 of the Title 47CFR must not exceed the limits shown in Table per Section 15.209.

FCC Part 15 Subpart C Paragraph 15.209		
Frequency [MHz]	Field Strength [uV/m]	Measured Distance [Meters]
0.009 - 0.490	2400/F (kHz)	300
0.490 - 1.705	24000/F (kHz)	30
1.705 - 30	30	30
30 - 88	100	3
88 - 216	150	3
216 - 960	200	3
Above 960	500	3

6.8.2. Test Procedure

KDB 789033 D02v02r01- Section G

6.8.3. Test Setting

Peak Measurements above 1GHz

1. Analyzer center frequency was set to the frequency of the radiated spurious emission of interest
2. RBW = 1MHz
3. VBW = 3MHz
4. Detector = Peak
5. Sweep time = Auto couple
6. Trace mode = Max hold
7. Trace was allowed to stabilize

Average Measurements above 1GHz (Method VB)

1. Analyzer center frequency was set to the frequency of the radiated spurious emission of interest
2. RBW = 1MHz
3. VBW; if the EUT is configured to transmit with duty cycle $\geq 98\%$, set VBW = 10Hz
4. If the EUT duty cycle is $< 98\%$, set VBW $\geq 1/T$. T is the minimum transmission duration

802.11a	VBW = 510Hz	802.11ax-HE20	VBW = 180Hz
802.11ac-VHT20	VBW = 180Hz	802.11ax-HE40	VBW = 180Hz
802.11ac-VHT40	VBW = 180Hz	802.11ax-HE80	VBW = 180Hz
802.11ac-VHT80	VBW = 180Hz		

5. Detector = Peak
6. Sweep time = Auto
7. Trace mode = Max hold
8. Trace was allowed to stabilize

6.8.4. Test Setup

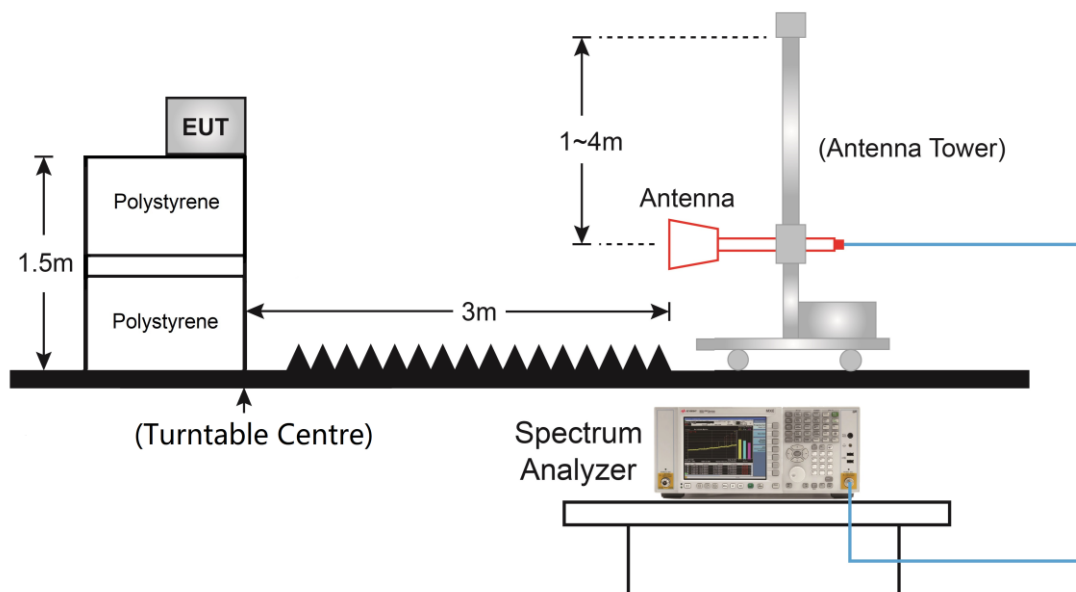

6.8.5. Test Result

Refer to Appendix A.8.

6.9. AC Conducted Emissions Measurement

6.9.1. Test Limit

FCC Part 15.207 Limits		
Frequency (MHz)	QP (dBuV)	AV (dBuV)
0.15 - 0.50	66 - 56	56 - 46
0.50 - 5.0	56	46
5.0 - 30	60	50

Note 1: The lower limit shall apply at the transition frequencies.

Note 2: The limit decreases linearly with the logarithm of the frequency in the range 0.15MHz to 0.5MHz.

6.9.2. Test Setup

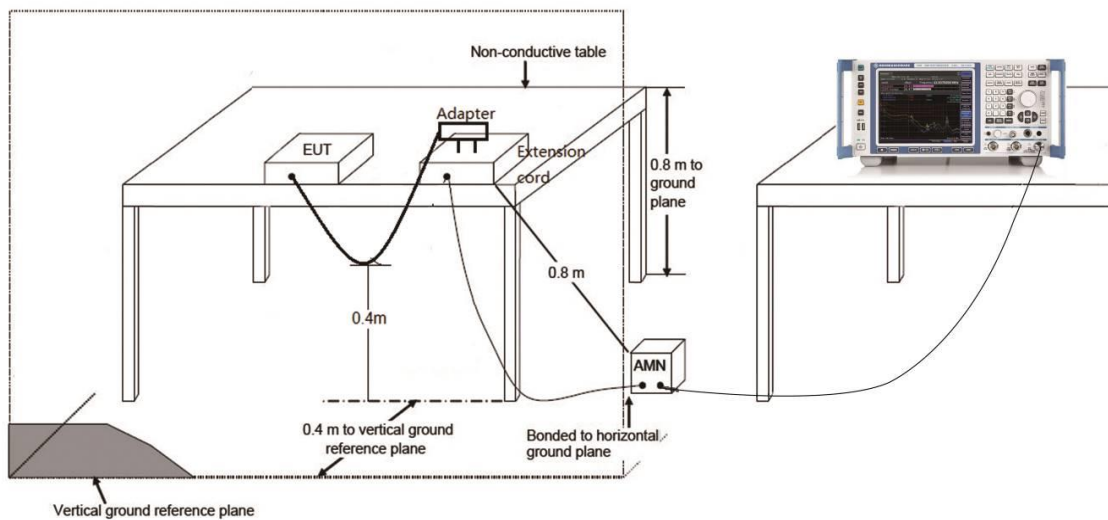

6.9.3. Test Result

Refer to Appendix A.9.

Appendix A – Test Result

A.1 Duty Cycle Test Result

Test Mode	Duty Cycle
802.11a	97.01%
802.11ac-VHT20	95.50%
802.11ac-VHT40	94.76%
802.11ac-VHT80	94.49%
802.11ac-VHT80+80	87.15%
802.11ax-HE20	95.53%
802.11ax-HE40	94.78%
802.11ax-HE80	95.03%
802.11ax-HE80+80	94.78%

Duty Cycle (T = Transmission Duration)

802.11a (T = 1.976ms)

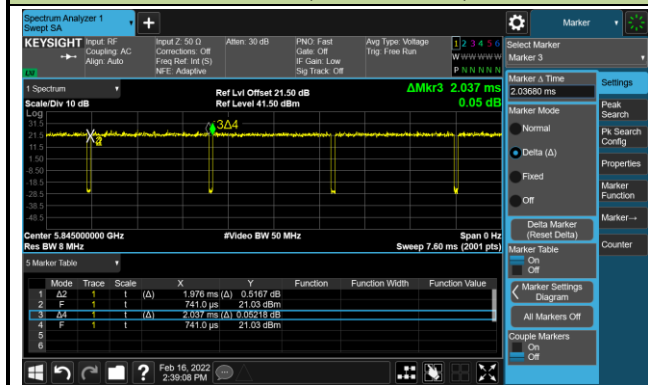

802.11ac-VHT20 (T = 5.415ms)

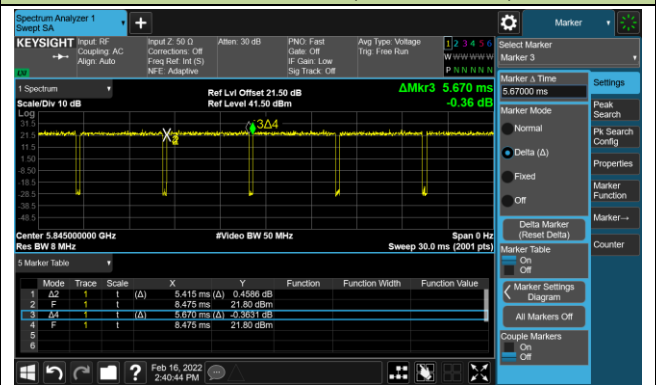

802.11ac-VHT40 (T = 5.430ms)

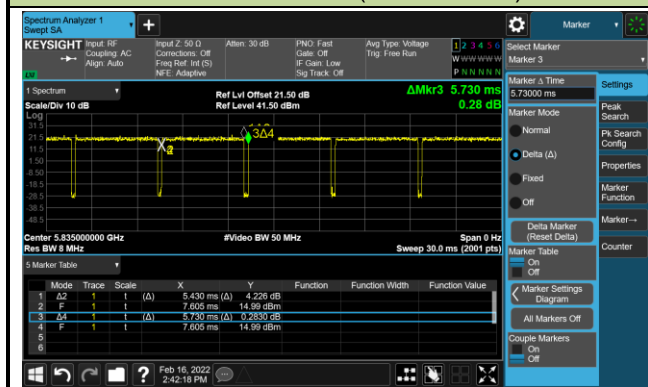

802.11ac-VHT80 (T = 5.400ms)

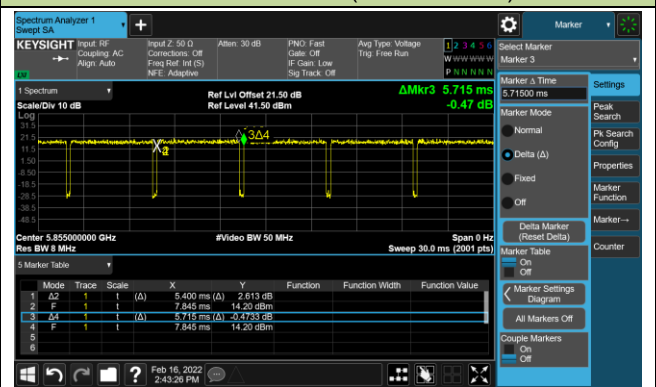

Duty Cycle (T = Transmission Duration)

802.11ac-VHT80+80 (T = 10.85ms)

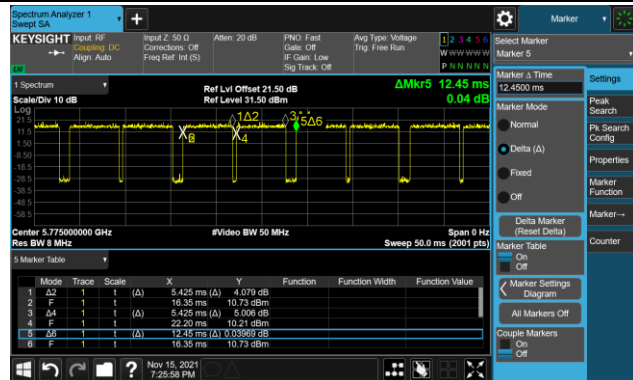

802.11ax-HE20 (T = 5.445ms)

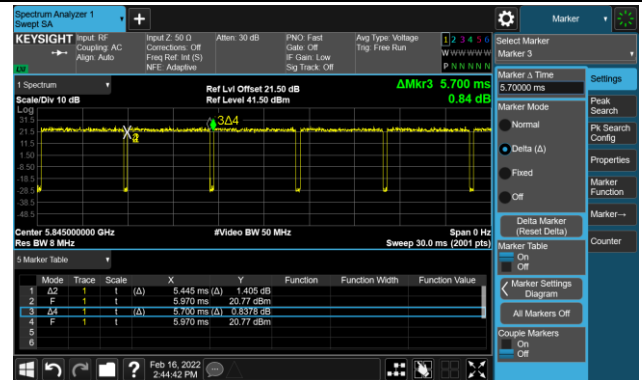

802.11ax-HE40 (T = 5.445ms)

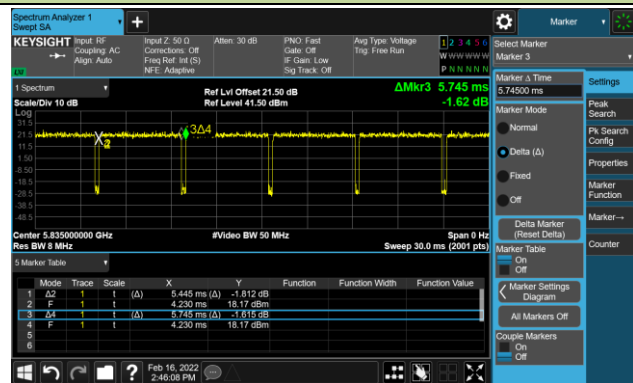

802.11ax-HE80 (T = 5.445ms)

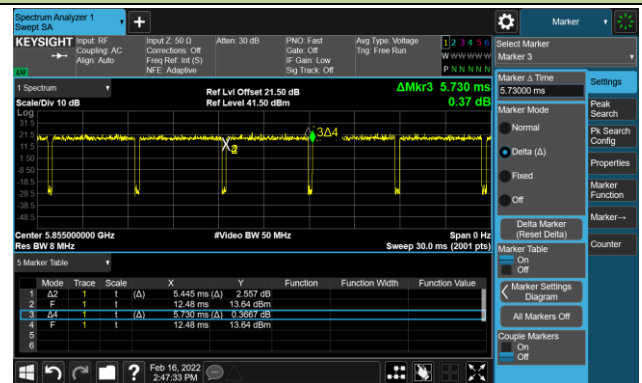

802.11ax-HE80+80 (T = 5.445ms)

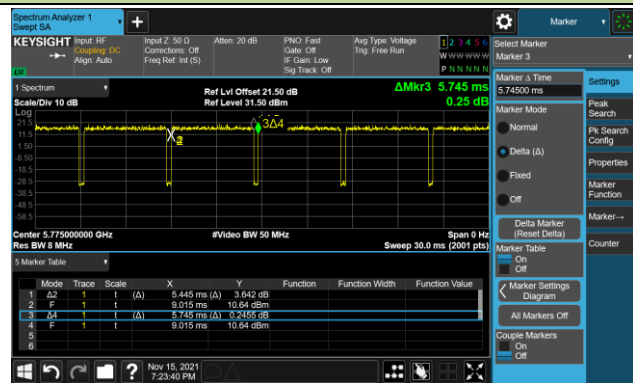

A.2 26dB & 99% Bandwidth Test Result

Test Site	WZ-SR5	Test Engineer	Luis Yang
Test Date	2021/10/15 ~ 2022/02/16		

Test Mode	Data Rate/ MCS	Channel No.	Frequency (MHz)	99% Bandwidth (MHz)	26dB Bandwidth (MHz)
11a	6Mbps	169	5845	16.37	19.53
11a	6Mbps	173	5865	16.40	19.49
11a	6Mbps	177	5885	16.67	26.55
11ac-VHT20	MCS0	169	5845	17.64	20.84
11ac-VHT20	MCS0	173	5865	17.62	20.54
11ac-VHT20	MCS0	177	5885	17.96	27.74
11ac-VHT40	MCS0	167	5835	36.09	40.71
11ac-VHT40	MCS0	175	5875	36.39	42.35
11ac-VHT80	MCS0	171	5855	75.43	81.49
11ac-VHT80+80	MCS0	155 + 171	5775 + 5855	153.96	163.20
11ax-HE20	MCS0	169	5845	18.91	20.37
11ax-HE20	MCS0	173	5865	18.97	21.27
11ax-HE20	MCS0	177	5885	19.03	23.98
11ax-HE40	MCS0	167	5835	37.67	40.65
11ax-HE40	MCS0	175	5875	37.83	42.96
11ax-HE80	MCS0	171	5855	77.09	81.47
11ax-HE80+80	MCS0	155 + 171	5775 + 5855	155.95	163.50

802.11a 26dB Bandwidth

Channel 169 (5845MHz)

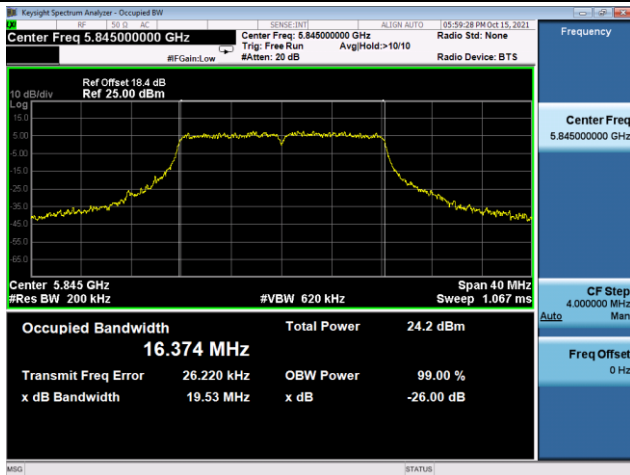

Channel 173 (5865MHz)

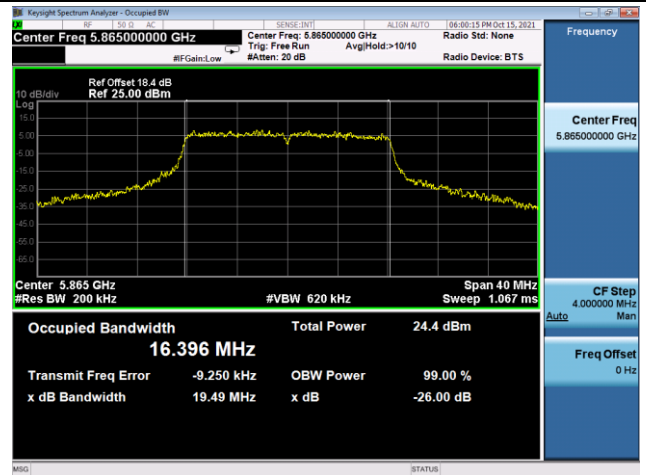

Channel 177 (5885MHz)

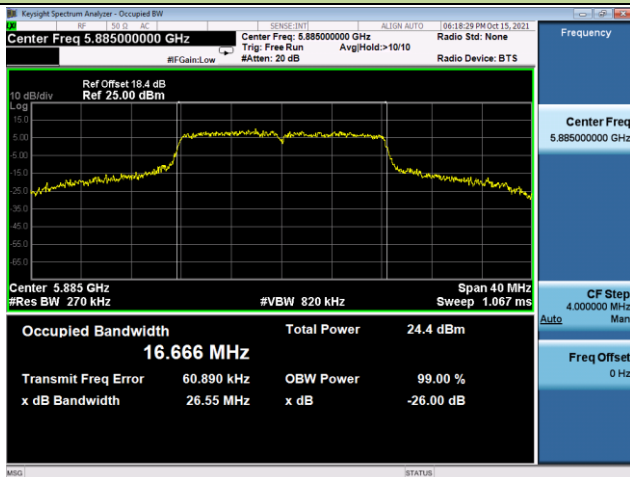

802.11ac-VHT20 26dB Bandwidth

Channel 169 (5845MHz)

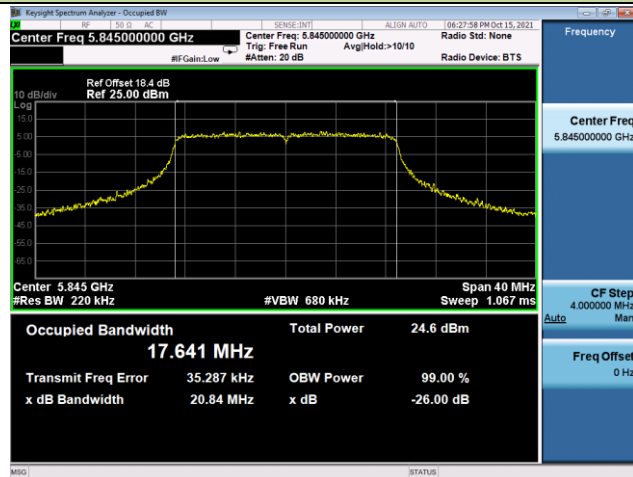

Channel 173 (5865MHz)

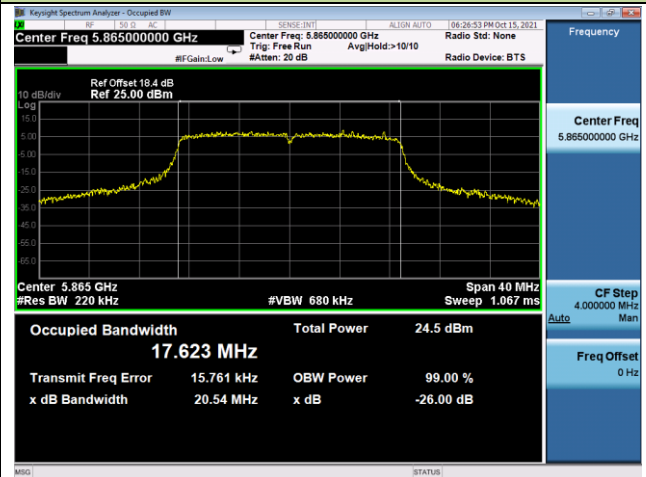

Channel 177 (5885MHz)

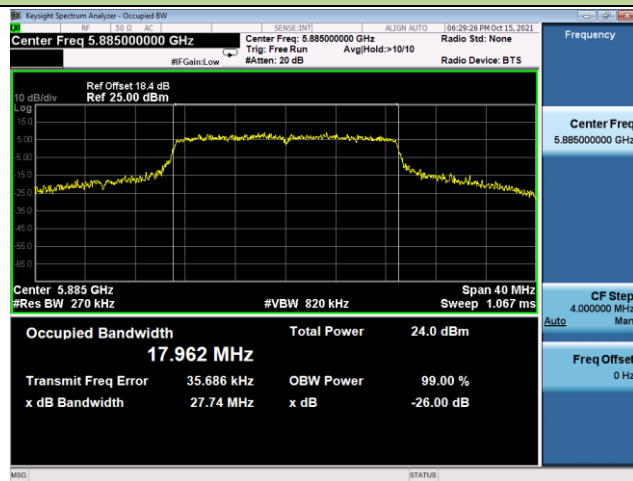

802.11ac-VHT40 26dB Bandwidth

Channel 167 (5835MHz)

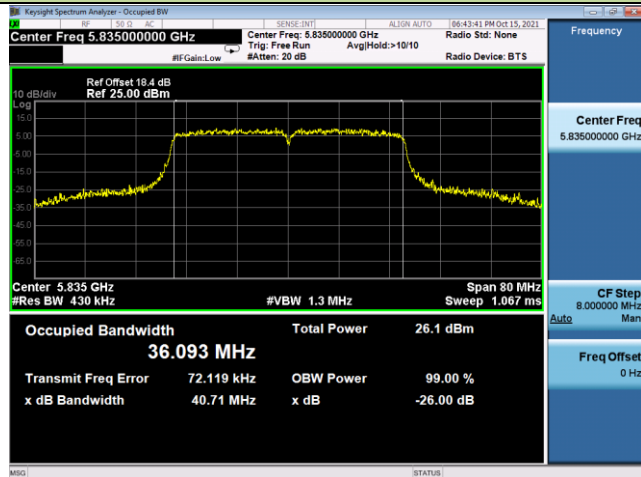

Channel 175(5875MHz)

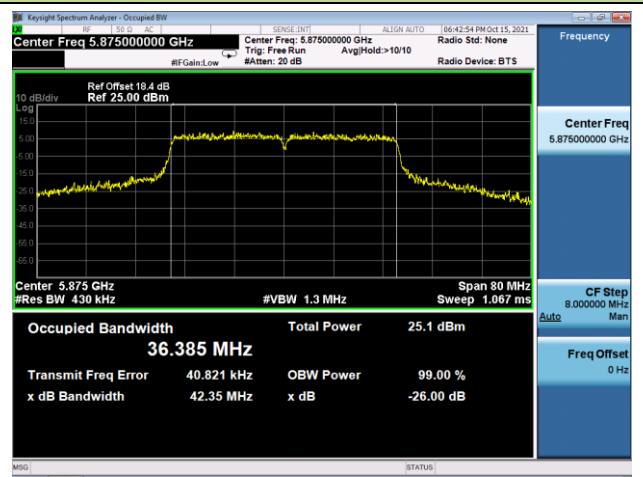

802.11ac-VHT80 26dB Bandwidth

Channel 171 (5855MHz)

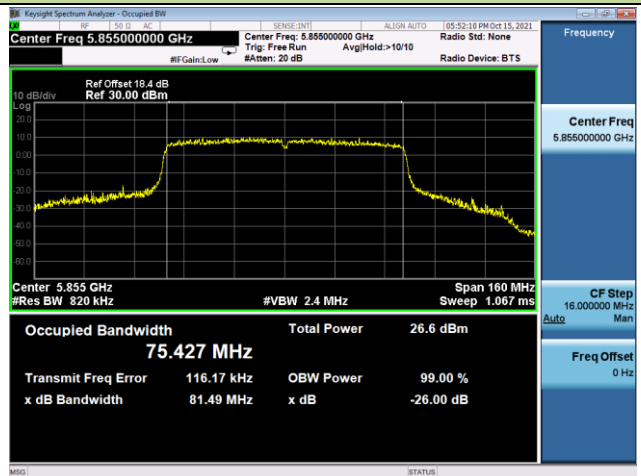

802.11ac-VHT80+80 26dB Bandwidth

Channel 155 + 171 (5775 + 5855MHz)

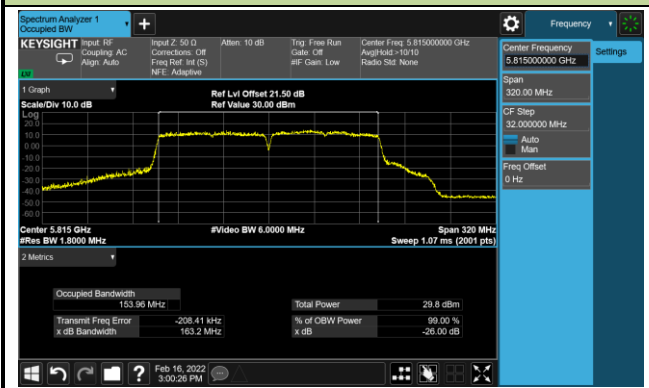

802.11ax-HE20 26dB Bandwidth

Channel 169 (5845MHz)

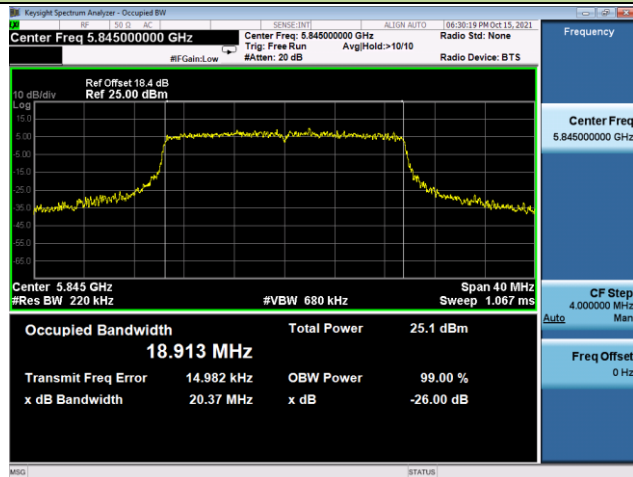

Channel 173 (5865MHz)

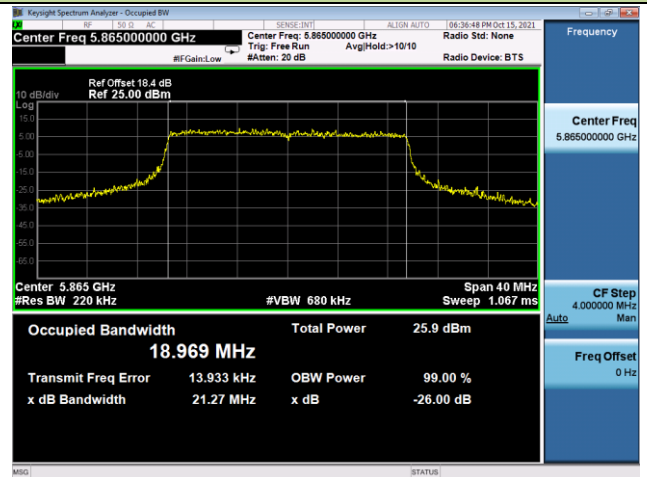

Channel 177 (5885MHz)

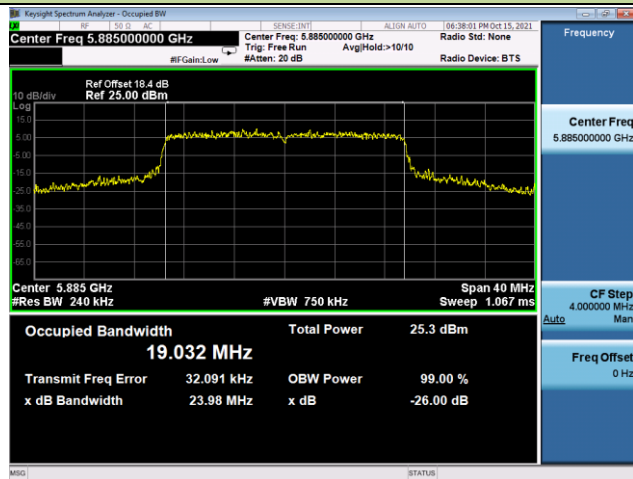

802.11ax-HE40 26dB Bandwidth

Channel 167 (5835MHz)

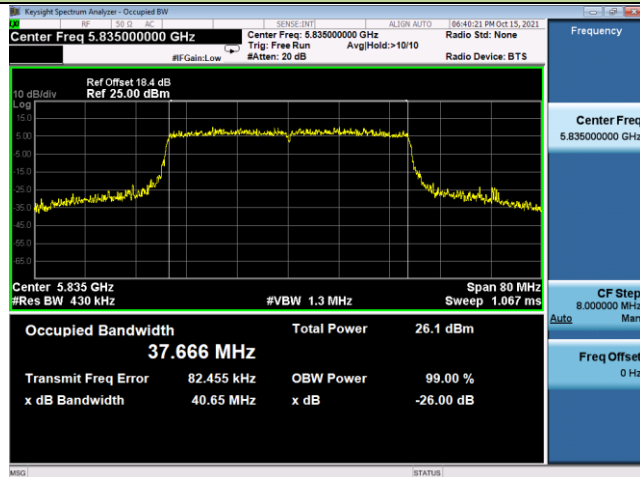

Channel 175(5875MHz)

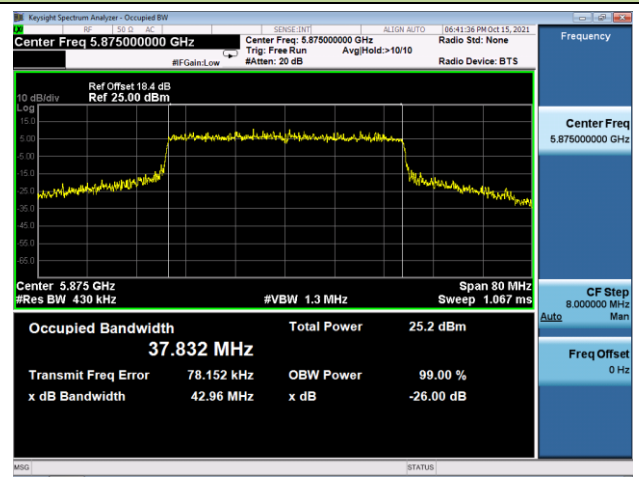

802.11ax-HE80 26dB Bandwidth

Channel 171 (5855MHz)



802.11ax-HE80+80 26dB Bandwidth

Channel 155 + 171 (5775 + 5855MHz)

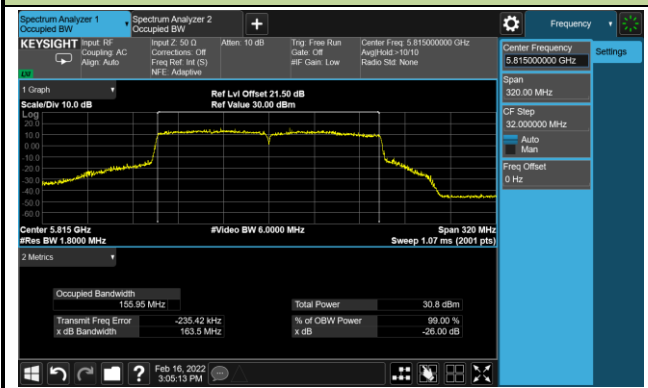

A.3 6dB Bandwidth Test Result

Test Site	WZ-SR5	Test Engineer	Luis Yang
Test Date	2021/10/15 ~ 2022/02/16		

Test Mode	Data Rate/ MCS	Channel No.	Frequency (MHz)	6dB Bandwidth (MHz)	Limit (MHz)
11a	6Mbps	169	5845	16.04	≥ 0.5
11a	6Mbps	173	5865	16.14	≥ 0.5
11a	6Mbps	177	5885	16.31	≥ 0.5
11ac-VHT20	MCS0	169	5845	17.53	≥ 0.5
11ac-VHT20	MCS0	173	5865	16.84	≥ 0.5
11ac-VHT20	MCS0	177	5885	17.60	≥ 0.5
11ac-VHT40	MCS0	167	5835	35.28	≥ 0.5
11ac-VHT40	MCS0	175	5875	36.44	≥ 0.5
11ac-VHT80	MCS0	171	5855	73.89	≥ 0.5
11ac-VHT80+80	MCS0	155 + 171	5775 + 5855	152.60	≥ 0.5
11ax-HE20	MCS0	169	5845	18.53	≥ 0.5
11ax-HE20	MCS0	173	5865	18.61	≥ 0.5
11ax-HE20	MCS0	177	5885	18.94	≥ 0.5
11ax-HE40	MCS0	167	5835	37.71	≥ 0.5
11ax-HE40	MCS0	175	5875	38.07	≥ 0.5
11ax-HE80	MCS0	171	5855	75.42	≥ 0.5
11ax-HE80+80	MCS0	155 + 171	5775 + 5855	155.10	≥ 0.5

802.11a 6dB Bandwidth

Channel 169 (5845MHz)

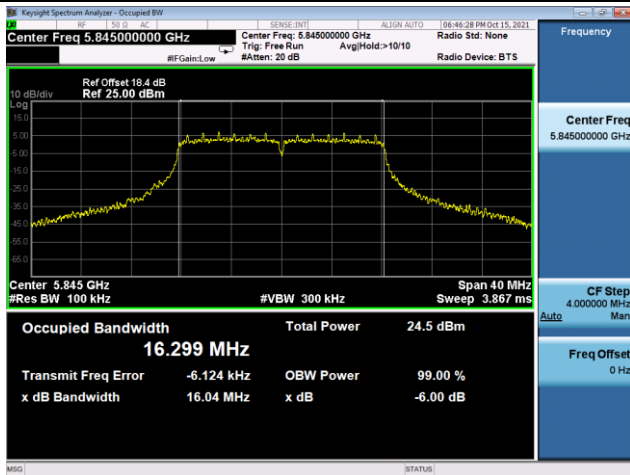

Channel 173 (5865MHz)

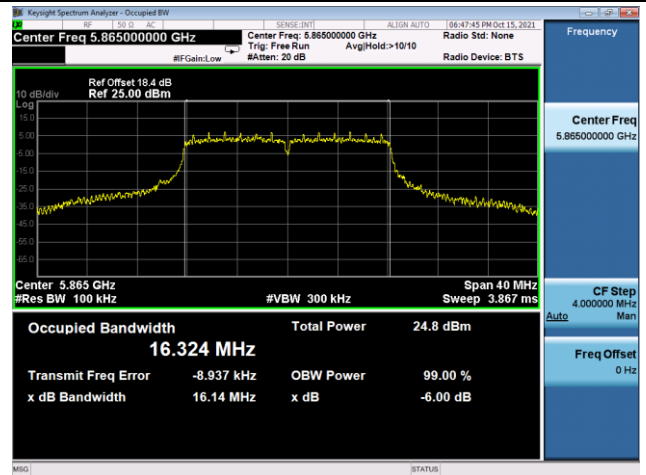

Channel 177 (5885MHz)

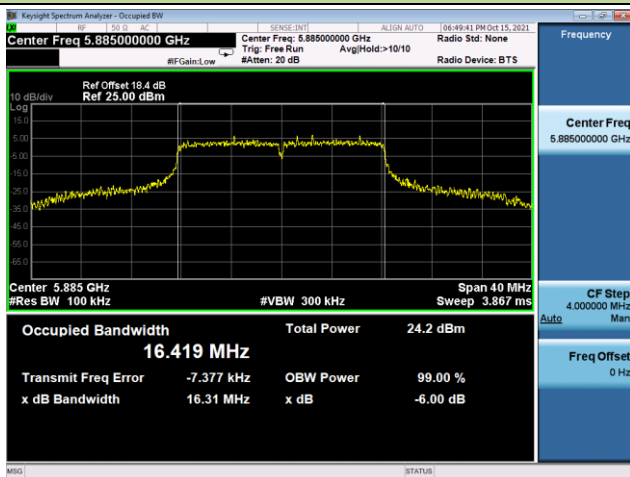

802.11ac-VHT20 6dB Bandwidth

Channel 169 (5845MHz)



Channel 173 (5865MHz)

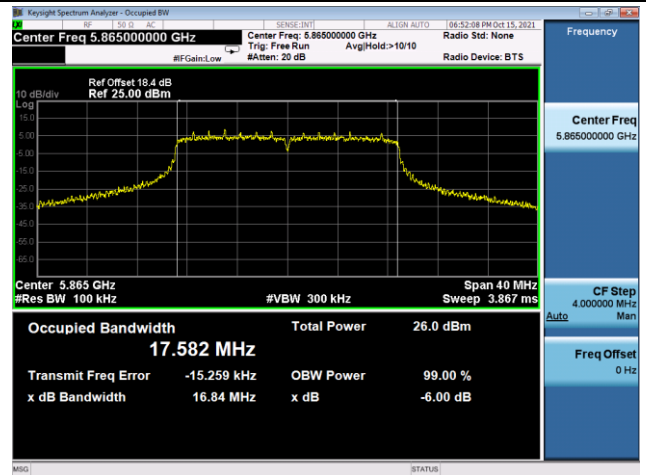

Channel 177 (5885MHz)

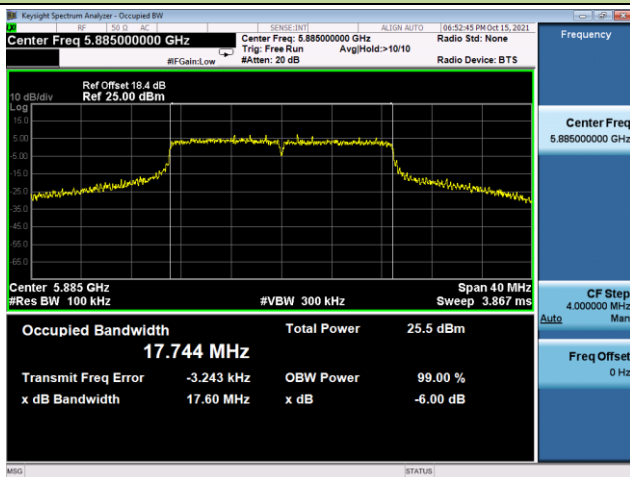

802.11ac-VHT40 6dB Bandwidth

Channel 167 (5835MHz)

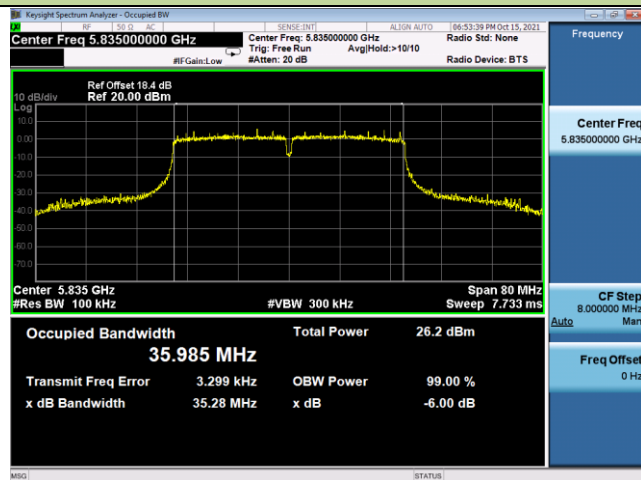

Channel 175(5875MHz)

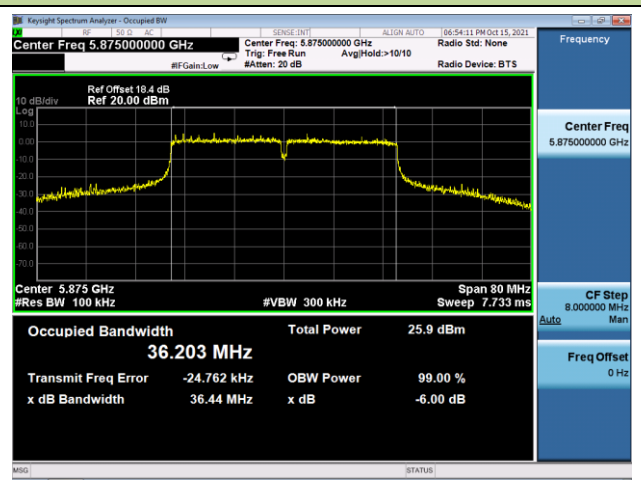

802.11ac-VHT80 6dB Bandwidth

Channel 171 (5855MHz)

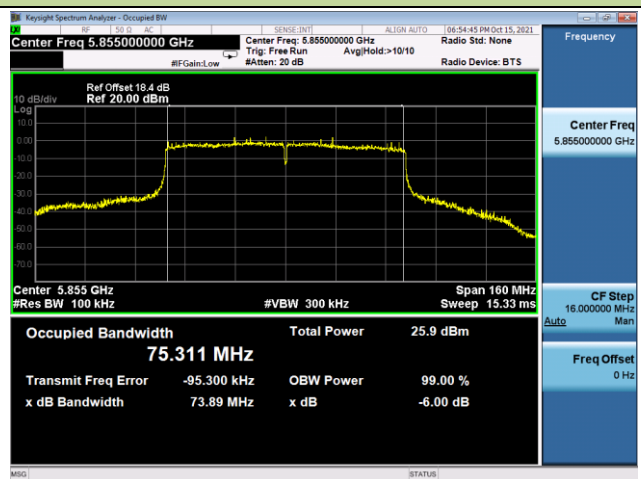

802.11ac-VHT80+80 6dB Bandwidth

Channel 155 + 171 (5775 + 5855MHz)

