

# MEASUREMENT REPORT

## FCC PART 15.247 / Bluetooth-LE

---



**FCC ID:** Q9DAPIN0635

**Applicant:** Hewlett Packard Enterprise Company

**Application Type:** Certification

**Product:** ACCESS POINT

**Model No.:** APIN0635

**Trademark:**  

**FCC Classification:** Digital Transmission System (DTS)

**FCC Rule Part(s):** Part15 Subpart C (Section 15.247)

**Test Procedure(s):** ANSI C63.10-2013

**Test Date:** January 22 ~ May 08, 2021

Reviewed By:   
( Paddy Chen )

Approved By:   
( Chenz Ker )



The test results relate only to the samples tested.

This equipment has been shown to be capable of compliance with the applicable technical standards as indicated in the measurement report and was tested in accordance with the measurement procedures specified in ANSI C63.10-2013. Test results reported herein relate only to the item(s) tested.

The test report shall not be reproduced except in full without the written approval of MRT Technology (Taiwan) Co., Ltd.

---

## Revision History

Report No.	Version	Description	Issue Date	Note
2101TW0003-U1	V1.0	Initial report	05-09-2021	Valid

---

## CONTENTS

Description	Page
<b>1. INTRODUCTION .....</b>	<b>6</b>
1.1. Scope .....	6
1.2. MRT Test Location .....	6
<b>2. PRODUCT INFORMATION .....</b>	<b>7</b>
2.1. Equipment Description.....	7
2.2. Product Specification Subjective to this Report.....	7
2.3. Working Frequencies for this Report.....	8
2.4. Description of EUT Filter.....	9
2.5. Description of Available Antennas.....	10
2.6. Description of Antenna RF Port .....	11
2.7. Duty Cycle .....	11
2.8. Description of Test Configuration and Software .....	12
2.9. EMI Suppression Device(s)/Modifications.....	12
2.10. Labeling Requirements.....	12
<b>3. DESCRIPTION OF TEST .....</b>	<b>13</b>
3.1. Measurement Procedure .....	13
3.2. AC Line Conducted Emissions .....	13
3.3. Radiated Emissions .....	14
<b>4. ANTENNA REQUIREMENTS.....</b>	<b>15</b>
<b>5. TEST EQUIPMENT CALIBRATION DATE.....</b>	<b>16</b>
<b>6. MEASUREMENT UNCERTAINTY.....</b>	<b>17</b>
<b>7. TEST RESULT .....</b>	<b>18</b>
7.1. Summary .....	18
7.2. 6dB Bandwidth Measurement.....	19
7.2.1. Test Limit .....	19
7.2.2. Test Procedure used.....	19
7.2.3. Test Setting.....	19
7.2.4. Test Setup.....	19
7.2.5. Test Result.....	20
7.3. Output Power Measurement.....	22
7.3.1. Test Limit .....	22
7.3.2. Test Procedure Used .....	22
7.3.3. Test Setting.....	22

---

7.3.4.	Test Setup.....	23
7.3.5.	Test Result.....	24
7.4.	Power Spectral Density Measurement.....	26
7.4.1.	Test Limit.....	26
7.4.2.	Test Procedure Used.....	26
7.4.3.	Test Setting.....	26
7.4.4.	Test Setup.....	26
7.4.5.	Test Result.....	27
7.5.	Conducted Band Edge and Out-of-Band Emissions.....	29
7.5.1.	Test Limit.....	29
7.5.2.	Test Procedure Used.....	29
7.5.3.	Test Setting.....	29
7.5.4.	Test Setup.....	30
7.5.5.	Test Result.....	31
7.6.	Radiated Spurious Emission Measurement.....	37
7.6.1.	Test Limit.....	37
7.6.2.	Test Procedure Used.....	37
7.6.3.	Test Setting.....	37
7.6.4.	Test Setup.....	39
7.6.5.	Test Result.....	40
7.7.	Radiated Restricted Band Edge Measurement.....	60
7.7.1.	Test Limit.....	60
7.7.2.	Test Procedure Used.....	61
7.7.3.	Test Setting.....	61
7.7.4.	Test Setup.....	62
7.7.5.	Test Result.....	63
7.8.	AC Conducted Emissions Measurement.....	87
7.8.1.	Test Limit.....	87
7.8.2.	Test Setup.....	87
7.8.3.	Test Result.....	88
<b>8.</b>	<b>CONCLUSION.....</b>	<b>90</b>
	<b>Appendix A - Test Setup Photograph.....</b>	<b>91</b>
	<b>Appendix B - EUT Photograph.....</b>	<b>92</b>

## General Information

<b>Applicant</b>	Hewlett Packard Enterprise Company
<b>Applicant Address</b>	3333 Scott Blvd, Santa Clara, CA 95054, USA
<b>Manufacturer</b>	Hewlett Packard Enterprise Company
<b>Manufacturer Address</b>	3333 Scott Blvd, Santa Clara, CA 95054, USA
<b>Test Site</b>	MRT Technology (Taiwan) Co., Ltd
<b>Test Site Address</b>	No. 38, Fuxing Second Rd., Guishan Dist., Taoyuan City 333, Taiwan (R.O.C)
<b>MRT FCC Registration No.</b>	291082
<b>FCC Rule Part(s)</b>	Part 15.247
<b>Test Device Serial No.</b>	DKS0BS0027 <input type="checkbox"/> Production <input checked="" type="checkbox"/> Pre-Production <input type="checkbox"/> Engineering

## Test Facility / Accreditations

1. MRT facility is a FCC registered (Reg. No. 291082) test facility with the site description report on file and is designated by the FCC as an Accredited Test Firm.
2. MRT facility is an IC registered (MRT Reg. No. 21723) test laboratory with the site description on file at Industry Canada.
3. MRT Lab is accredited to ISO 17025 by the Taiwan Accreditation Foundation (TAF Cert. No. 3261) in EMC, Telecommunications and Radio testing for FCC (Designation Number: TW3261), Industry Taiwan, EU and TELEC Rules.

## 1. INTRODUCTION

### 1.1. Scope

Measurement and determination of electromagnetic emissions (EMC) of radio frequency devices including intentional and/or unintentional radiators for compliance with the technical rules and regulations of the Federal Communications Commission and the Innovation, Science and Economic Development Canada and Certification and Engineering Bureau.

### 1.2. MRT Test Location

The map below shows the location of the MRT LABORATORY, its proximity to the Taoyuan City. These measurement tests were conducted at the MRT Technology (Taiwan) Co., Ltd. Facility located at No.38, Fuxing 2nd Rd., Guishan Dist., Taoyuan City 33377, Taiwan (R.O.C).

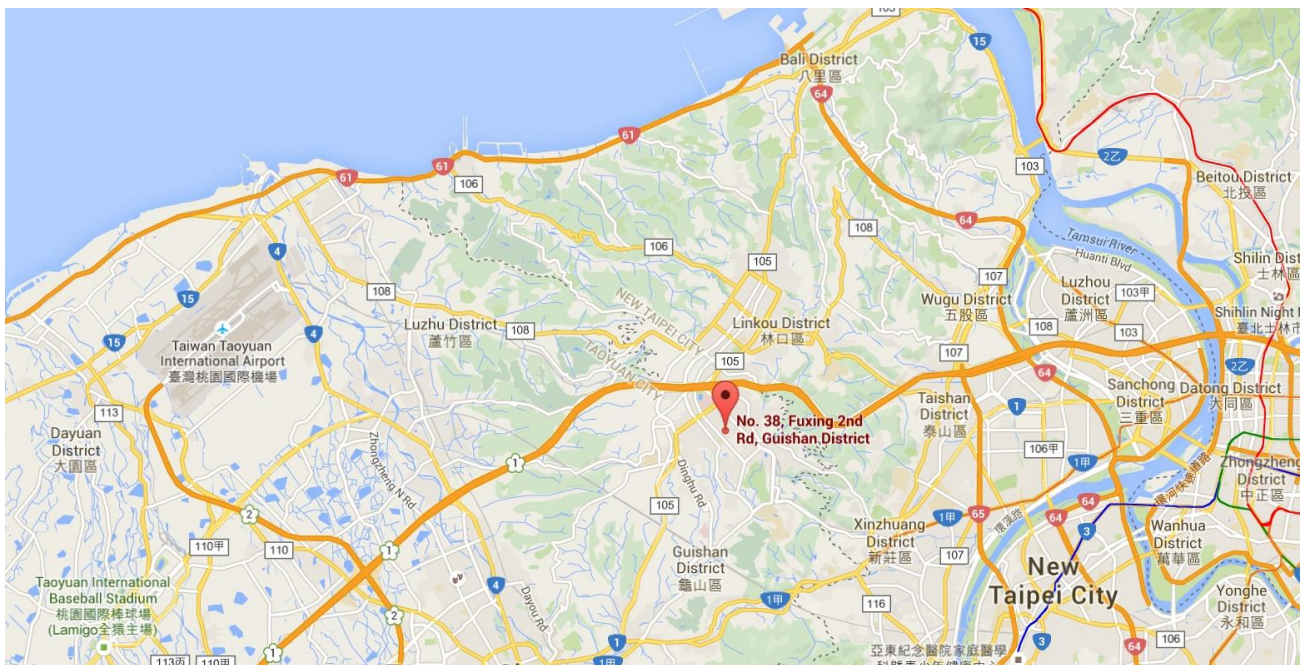

## 2. PRODUCT INFORMATION

### 2.1. Equipment Description

Product Name	ACCESS POINT
Model No.	APIN0635
Software Version	20210105 spf.11.3.cs
Wi-Fi Specification	802.11a/b/g/n/ac/ax
Bluetooth Specification	v5.0 single mode, BLE only
Zigbee Specification	802.15.4
Operating Temperature	0 ~ 50 °C
Power Type	AC Adapter or PoE input
Operating Environment	Indoor Use

### 2.2. Product Specification Subjective to this Report

Bluetooth Frequency	2402 ~ 2480MHz
Bluetooth Version	v5.0 single mode, BLE only
Type of modulation	GFSK
Data Rate	1Mbps & 2Mbps

Note: For other features of this EUT, test report will be issued separately.

### 2.3. Working Frequencies for this Report

Channel	Frequency	Channel	Frequency	Channel	Frequency
00	2402 MHz	01	2404 MHz	02	2406 MHz
03	2408 MHz	04	2410 MHz	05	2412 MHz
06	2414 MHz	07	2416 MHz	08	2418 MHz
09	2420 MHz	10	2422 MHz	11	2424 MHz
12	2426 MHz	13	2428 MHz	14	2430 MHz
15	2432 MHz	16	2434 MHz	17	2436 MHz
18	2438 MHz	19	2440 MHz	20	2442 MHz
21	2444 MHz	22	2446 MHz	23	2448 MHz
24	2450 MHz	25	2452 MHz	26	2454 MHz
27	2456 MHz	28	2458 MHz	29	2460 MHz
30	2462 MHz	31	2464 MHz	32	2466 MHz
33	2468 MHz	34	2470 MHz	35	2472 MHz
36	2474 MHz	37	2476 MHz	38	2478 MHz
39	2480 MHz	--	--	--	--



## 2.4. Description of EUT Filter

Filter	Specification	Remark
<b>Wi-Fi</b>		
Filter 1#	Band Pass Filter (2412-2472)	Allowing any transmission on all channels
Filter 2#	Band Pass Filter (2402-2447)	Allowing any transmission on 20MHz channels 1 thru 6.
Filter 3#	Band Pass Filter (2452-2472)	Allowing any transmission on 20MHz channel 11
<b>Bluetooth &amp; Zigbee</b>		
Filter 4#	Band Pass Filter (2402-2480)	Allowing any transmission on all channels
Filter 5#	Band Pass Filter (2402-2430)	Allowing transmission on BLE channels 37 (2402MHz) and 38 (2426MHz) and Zigbee channel 11 (2405MHz)
Filter 6#	Band Pass Filter (2478-2482)	Allowing transmission on BLE channel 39 (2480MHz) and Zigbee channel 26 (2480MHz)

### Working Mode

Wi-Fi	Bluetooth	Remark
Filter 1#	Filter 4#	Filter 1# or Filter 4# work alone
Filter 2#	Filter 6#	Transmission simultaneously
Filter 3#	Filter 5#	Transmission simultaneously
Note: Filter groups on the 2.4GHz Wi-Fi and BLE/Zigbee outputs to prevent reverse IMD when both 2.4GHz Wi-Fi and BLE/Zigbee are transmitting simultaneously		

## 2.5. Description of Available Antennas

Antenna Type	Frequency Band (GHz)	Max Peak Gain (dBi)	CDD Directional Gain (dBi)		BF Directional Gain (dBi)
			For Power	For PSD	
Wi-Fi Internal Antenna (2*2 MIMO)					
PIFA	2.4 ~ 2.5	2.90	2.90	5.91	5.91
	5.15 ~ 5.9	4.90	4.90	7.91	7.91
	5.9 ~ 7.2	4.30	4.30	4.30	4.30
Bluetooth / ZigBee Internal Antenna					
PIFA	2.4 ~ 2.5		3.0		

Note:

- The EUT supports Cyclic Delay Diversity (CDD) mode, and CDD signals are correlated. For CDD transmissions, directional gain is calculated as follows,  $N_{ANT} = 2$ ,  $N_{SS} = 1$ . If all antennas have the same gain,  $G_{ANT}$ , Directional gain =  $G_{ANT} + \text{Array Gain}$ , where Array Gain is as follows.
  - For power spectral density (PSD) measurements on all devices,
 
$$\text{Array Gain} = 10 \log (N_{ANT} / N_{SS}) \text{ dB} = 3.01;$$
  - For power measurements on IEEE 802.11 devices,
 
$$\text{Array Gain} = 0 \text{ dB for } N_{ANT} \leq 4;$$
- The EUT also supports Beam Forming mode, and the Beam Forming support 802.11n/ac/ax, not include 802.11a/b/g. Directional gain =  $G_{ANT} + \text{BF Gain}$ . BF mode power setting will be less than or equal to CDD power setting.
- Wi-Fi 6E band antennas are cross polarized, the detail refer to antenna specification.
- All antenna information is provided by the manufacturer, test laboratory will not be responsible if any error.

## 2.6. Description of Antenna RF Port

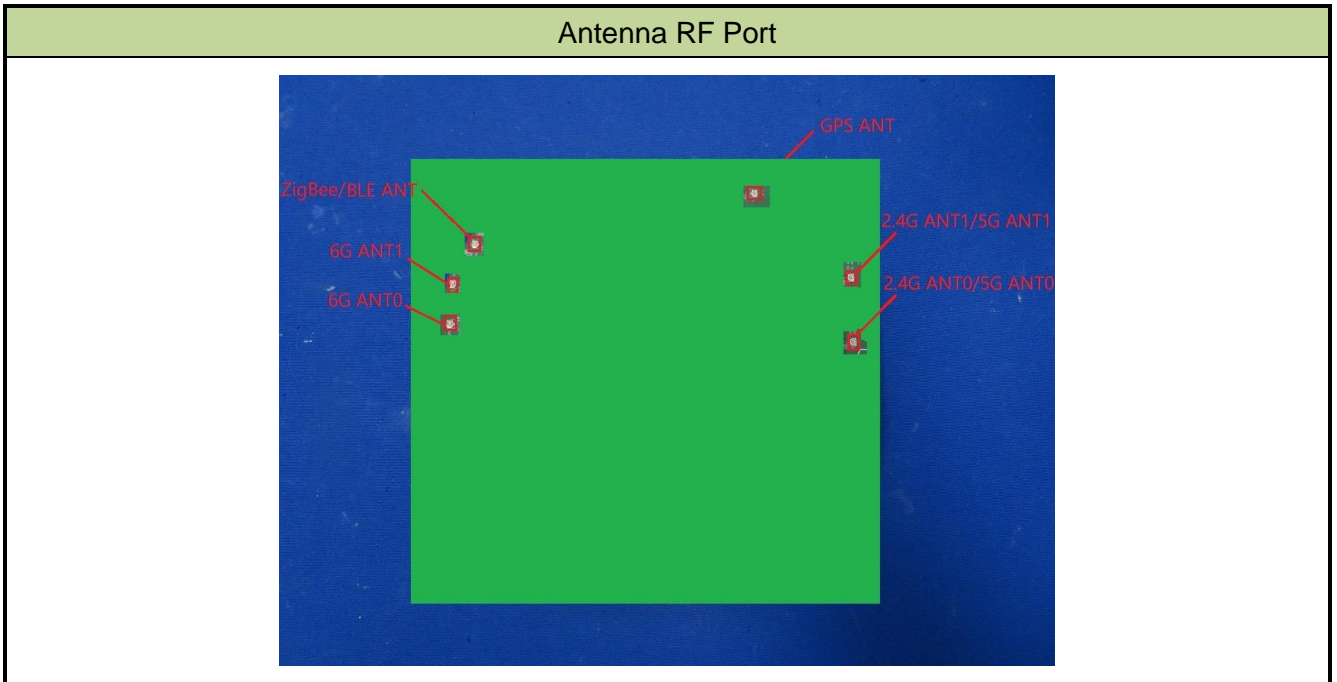

## 2.7. Duty Cycle

The maximum achievable duty cycles were determined based on measurements performed on a spectrum analyzer in zero-span mode with RBW = 8MHz, VBW = 50MHz. The RBW and VBW were both greater than 50/T, where T is the minimum transmission duration, and the number of sweep points across T was greater than 100. The duty cycles are as follows:

Test Mode	Duty Cycle
BLE - 1Mbps	16.42%
BLE - 2Mbps	9.56%

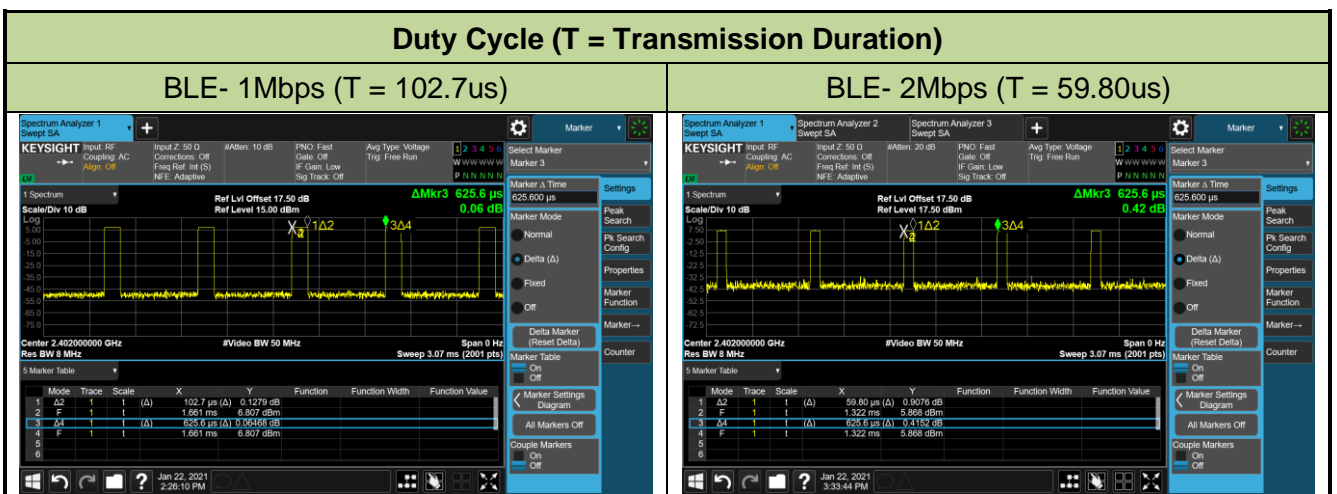

### 2.8. Description of Test Configuration and Software

The device was tested per the guidance ANSI C63.10-2013 was used to reference the appropriate EUT setup for radiated emissions testing and AC line conducted testing.

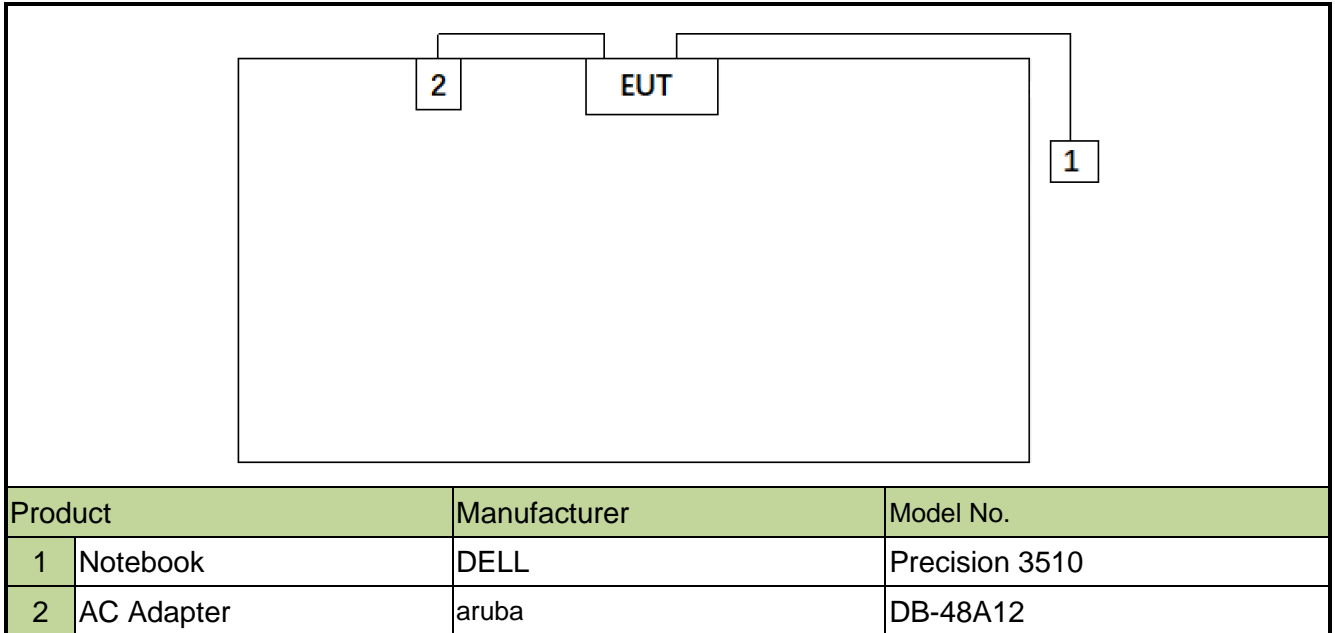

Note 1: The test utility software used during testing was “telnet.exe” and command was provided by the manufacturer.

Note 2: Detail power setting refer to operation description.

### 2.9. EMI Suppression Device(s)/Modifications

No EMI suppression device(s) were added and/or no modifications were made during testing.

### 2.10. Labeling Requirements

Per 2.1074 & 15.19; Docket 95-19

The label shall be permanently affixed at a conspicuous location on the device; instruction manual or pamphlet supplied to the user and be readily visible to the purchaser at the time of purchase. However, when the device is so small wherein placement of the label with specified statement is not practical, only the FCC ID must be displayed on the device per Section 15.19(a)(5). Please see attachment for FCC ID label and label location.

### **3. DESCRIPTION OF TEST**

#### **3.1. Measurement Procedure**

The measurement procedure described in the document titled “American National Standard of Procedures for Compliance Testing of Unlicensed Wireless Devices” (ANSI C63.10-2013) was used in the measurement.

#### **3.2. AC Line Conducted Emissions**

The line-conducted facility is located inside an 8'x4'x4' shielded enclosure. A 1m x 2m wooden table 80cm high is placed 40cm away from the vertical wall and 80cm away from the sidewall of the shielded room. Two 10kHz-30MHz, 50Ω/50uH Line-Impedance Stabilization Networks (LISNs) are bonded to the shielded room floor. Power to the LISNs is filtered by external high-current high-insertion loss power line filters. These filters attenuate ambient signal noise from entering the measurement lines. These filters are also bonded to the shielded enclosure.

The EUT is powered from one LISN and the support equipment is powered from the second LISN. All interconnecting cables more than 1 meter were shortened to a 1 meter length by non-inductive bundling (serpentine fashion) and draped over the back edge of the test table. All cables were at least 40cm above the horizontal reference ground-plane. Power cables for support equipment were routed down to the second LISN while ensuring that that cables were not draped over the second LISN.

Sufficient time for the EUT, support equipment, and test equipment was allowed in order for them to warm up to their normal operating condition. The RF output of the LISN was connected to the receiver and exploratory measurements were made to determine the frequencies producing the maximum emission from the EUT. The receiver was scanned from 150kHz to 30MHz. The detector function was set to peak mode for exploratory measurements while the bandwidth of the analyzer was set to 9kHz. The EUT, support equipment, and interconnecting cables were arranged and manipulated to maximize each emission. Each emission was also maximized by varying: power lines, the mode of operation or data exchange speed, or support equipment whichever determined the worst-case emission. Once the worst case emissions have been identified, the one EUT cable configuration/arrangement and mode of operation that produced these emissions were used for final measurements on the same test site. The analyzer is set to CISPR quasi-peak and average detectors with a 9kHz resolution bandwidth for final measurements.

An extension cord was used to connect to a single LISN which powered by EUT. The extension cord was calibrated with LISN, the impedance and insertion loss are compliance with the requirements as stated in ANSI C63.10-2013.

### 3.3. Radiated Emissions

The radiated test facilities consisted of an indoor 3 meter semi-anechoic chamber used for final measurements and exploratory measurements, when necessary. The measurement area is contained within the semi-anechoic chamber which is shielded from any ambient interference. For measurements above 1GHz absorbers are arranged on the floor between the turn table and the Antenna mast in such a way so as to maximize the reduction of reflections. For measurements below 1GHz, the absorbers are removed. A MF Model 210SS turntable is used for radiated measurement. It is a continuously rotatable, remote controlled, metallic turntable and 2 meters (6.56 ft.) in diameter. The turn table is flush with the raised floor of the chamber in order to maintain its function as a ground plane. An 80cm high PVC support structure is placed on top of the turntable. For all measurements, the spectrum was scanned through all EUT azimuths and from 1 to 4 meter receive Antenna height using a broadband Antenna from 30MHz up to the upper frequency shown in 15.33(b)(1) depending on the highest frequency generated or used in the device or on which the device operates or tunes. For frequencies above 1GHz, linearly polarized double ridge horn Antennas were used. For frequencies below 30MHz, a calibrated loop Antenna was used. When exploratory measurements were necessary, they were performed at 1 meter test distance inside the semi-anechoic chamber using broadband Antennas, broadband amplifiers, and spectrum analyzers to determine the frequencies and modes producing the maximum emissions. Sufficient time for the EUT, support equipment, and test equipment was allowed in order for them to warm up to their normal operating condition. The test set-up for frequencies below 1GHz was placed on top of the 0.8 meter high, 1 x 1.5 meter table; and test set-up for frequencies 1-40GHz was placed on top of the 1.5 meter high, 1 x 1.5 meter table. The EUT, support equipment, and interconnecting cables were arranged and manipulated to maximize each emission. Appropriate precaution was taken to ensure that all emissions from the EUT were maximized and investigated. The system configuration, clock speed, mode of operation or video resolution, if applicable, turntable azimuth, and receive Antenna height was noted for each frequency found.

Final measurements were made in the semi-anechoic chamber using calibrated, linearly polarized broadband and horn Antennas. The test setup was configured to the setup that produced the worst case emissions. The spectrum analyzer was set to investigate all frequencies required for testing to compare the highest radiated disturbances with respect to the specified limits. The turntable containing the EUT was rotated through 360 degrees and the height of the receive Antenna was varied 1 to 4 meters and stopped at the azimuth and height producing the maximum emission. Each emission was maximized by changing the orientation of the EUT through three orthogonal planes and changing the polarity of the receive Antenna, whichever produced the worst-case emissions. According to 3dB Beam-Width of horn Antenna, the horn Antenna should be always directed to the EUT when rising height.

## 4. ANTENNA REQUIREMENTS

### **Excerpt from §15.203 of the FCC Rules/Regulations:**

“An intentional radiator antenna shall be designed to ensure that no antenna other than that furnished by the responsible party can be used with the device. The use of a permanently attached antenna or of an antenna that uses a unique coupling to the intentional radiator shall be considered sufficient to comply with the provisions of this section.”

- The antenna of the device is **permanently attached**.
- There are no provisions for connection to an external antenna.

### **Conclusion:**

The unit complies with the requirement of §15.203.

## 5. TEST EQUIPMENT CALIBRATION DATE

### Conducted Emissions

Instrument	Manufacturer	Type No.	Asset No.	Cali. Interval	Cali. Due Date
Two-Line V-Network	R&S	ENV 216	MRTTWA00019	1 year	2022/3/23
Two-Line V-Network	R&S	ENV 216	MRTTWA00020	1 year	2022/4/24
8-Wire ISN (T8)	R&S	ENY81	MRTTWA00018	1 year	2021/5/25
EMI Test Receiver	R&S	ESR3	MRTTWA00045	1 year	2021/5/26
Temperature/Humidity Meter	TFA	35.1078.10.IT	MRTTWA00033	1 year	2021/5/28

### Radiated Emissions

Instrument	Manufacturer	Type No.	Asset No.	Cali. Interval	Cali. Due Date
Active Loop Antenna	SCHWARZBECK	FMZB 1519B	MRTTWA00002	1 year	2022/4/27
Broadband TRILOG Antenna	SCHWARZBECK	VULB 9162	MRTTWA00001	1 year	2021/10/5
Broadband Horn antenna	SCHWARZBECK	BBHA 9120D	MRTTWA00003	1 year	2022/4/24
Breitband Horn antenna	SCHWARZBECK	BBHA 9170	MRTTWA00004	1 year	2022/4/24
Broadband Preamplifier	SCHWARZBECK	BBV 9718	MRTTWA00005	1 year	2022/4/24
Broadband Amplifier	SCHWARZBECK	BBV 9721	MRTTWA00006	1 year	2022/4/24
Signal Analyzer	R&S	FSV40	MRTTWA00007	1 year	2022/3/23
EMI Test Receiver	R&S	ESR3	MRTTWA00009	1 year	2022/3/24
EXA Signal Analyzer	KEYSIGHT	N9010A	MRTTWA00012	1 year	2021/10/14
Antenna Cable	HUBERSUHNER	SF106	MRTTWE00010	1 year	2021/6/16
Temperature/Humidity Meter	TFA	35.1078.10.IT	MRTTWA00032	1 year	2021/5/29

### Conducted Test Equipment

Instrument	Manufacturer	Type No.	Asset No.	Cali. Interval	Cali. Due Date
X-Series USB Peak and Average Power Sensor	KEYSIGHT	U2021XA	MRTTWA00014	1 year	2022/4/24
EXA Signal Analyzer	KEYSIGHT	N9010A	MRTTWA00012	1 year	2021/10/14
EXA Signal Analyzer	KEYSIGHT	N9010B	MRTTWA00074	1 year	2021/7/11
Attenuator	WTI	218FS-20	MRTTWE00026	1 year	2021/5/30
Attenuator	WTI	218FS-10	MRTTWE00027	1 year	2021/5/30
Attenuator	WTI	218FS-06	MRTTWE00028	1 year	2021/5/30
Temperature/Humidity Meter	TFA	35.1078.10.IT	MRTTWA00033	1 year	2021/5/28

Software	Version	Function
v3	9.160520a	EMI Test Software



## 6. MEASUREMENT UNCERTAINTY

Where relevant, the following test uncertainty levels have been estimated for tests performed on the EUT as specified in CISPR 16-4-2. This uncertainty represents an expanded uncertainty expressed at approximately the 95% confidence level using a coverage factor of  $k = 2$ .

<b>AC Conducted Emission Measurement</b>
Measuring Uncertainty for a Level of Confidence of 95% ( $U=2Uc(y)$ ): 150kHz~30MHz: 2.53dB
<b>Radiated Emission Measurement</b>
Measuring Uncertainty for a Level of Confidence of 95% ( $U=2Uc(y)$ ): 9kHz ~ 1GHz: 4.25dB 1GHz ~ 40GHz: 4.45dB
<b>Conducted Power</b>
Measuring Uncertainty for a Level of Confidence of 95% ( $U=2Uc(y)$ ): $\pm 0.84$ dB
<b>Conducted Spurious Emission</b>
Measuring Uncertainty for a Level of Confidence of 95% ( $U=2Uc(y)$ ): $\pm 2.65$ dB
<b>Occupied Bandwidth</b>
Measuring Uncertainty for a Level of Confidence of 95% ( $U=2Uc(y)$ ): 3.3%
<b>Temp. / Humidity</b>
Measuring Uncertainty for a Level of Confidence of 95% ( $U=2Uc(y)$ ): $\pm 0.82^{\circ}\text{C} / \pm 3\%$

## 7. TEST RESULT

### 7.1. Summary

FCC Part Section(s)	Test Description	Test Limit	Test Condition	Test Result	Reference
15.247(a)(2)	6dB Bandwidth	$\geq 500\text{kHz}$	Conducted	Pass	Section 7.2
15.247(b)(3)	Output Power	$\leq 1\text{Watt}$		Pass	Section 7.3
15.247(e)	Power Spectral Density	$\leq 8\text{dBm} / 3\text{kHz}$		Pass	Section 7.4
15.247(d)	Band Edge / Out-of-Band Emissions	$\geq 20\text{dBc (Peak)}$		Pass	Section 7.5
15.205 15.209	General Field Strength (Restricted Bands and Radiated Emission)	Emissions in restricted bands must meet the radiated limits detailed in 15.209	Radiated	Pass	Section 7.6 & 7.7
15.207	AC Conducted Emissions 150kHz - 30MHz	< FCC 15.207 limits	Line Conducted	Pass	Section 7.8

Notes:

- The analyzer plots shown in this section were all taken with a correction table loaded into the analyzer. The correction table was used to account for the losses of the cables and attenuators used as part of the system to connect the EUT to the analyzer at all frequencies of interest.
- All modes of operation and data rates were investigated. For radiated emission test, every axis (X, Y, Z) was also verified. The test results shown in the following sections represent the worst case emissions.
- Determining compliance is based on the test results met the regulation limits or requirements declared by clients, and the test results don't take into account the value of measurement uncertainty.

Test Items	Filter 4#	Filter 5#	Filter 6#
6dB Bandwidth	•		
Output Power	•	•	•
Power Spectral Density	•		
Band Edge / Out-of-Band Emissions	•	•	•
Radiated Spurious Emission	•	•	•
Radiated Band Edge	•	•	•
AC Conducted Emissions 150kHz - 30MHz	•		

## 7.2. 6dB Bandwidth Measurement

### 7.2.1. Test Limit

The minimum 6dB bandwidth shall be at least 500 kHz.

### 7.2.2. Test Procedure used

ANSI C63.10-2013 Section 11.8

### 7.2.3. Test Setting

1. The Spectrum's automatic bandwidth measurement capability was used to perform the 6dB bandwidth measurement. The "X" dB bandwidth parameter was set to  $X = 6$ . The bandwidth measurement was not influenced by any intermediate power nulls in the fundamental emission.
2. Set RBW = 100 kHz
3. VBW  $\geq 3 \times$  RBW
4. Detector = Peak
5. Trace mode = max hold
6. Sweep = auto couple
7. Allow the trace was allowed to stabilize

### 7.2.4. Test Setup

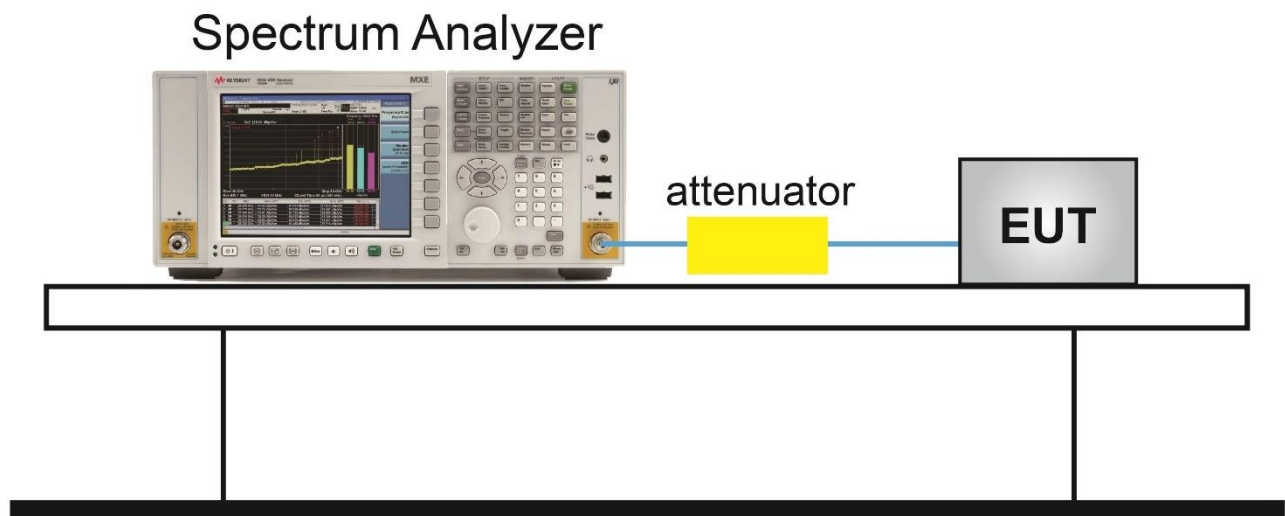

### 7.2.5. Test Result

Product	ACCESS POINT	Test Engineer	Eric Lin
Test Site	SR2	Test Date	2021/01/22

Test Mode	Data Rate (Mbps)	Channel No.	Frequency (MHz)	6dB Bandwidth (MHz)	Limit (MHz)	Result
BLE	1	00	2402	0.692	≥ 0.5	Pass
BLE	1	20	2442	0.690	≥ 0.5	Pass
BLE	1	39	2480	0.689	≥ 0.5	Pass
BLE	2	00	2402	1.184	≥ 0.5	Pass
BLE	2	20	2442	1.187	≥ 0.5	Pass
BLE	2	39	2480	1.183	≥ 0.5	Pass

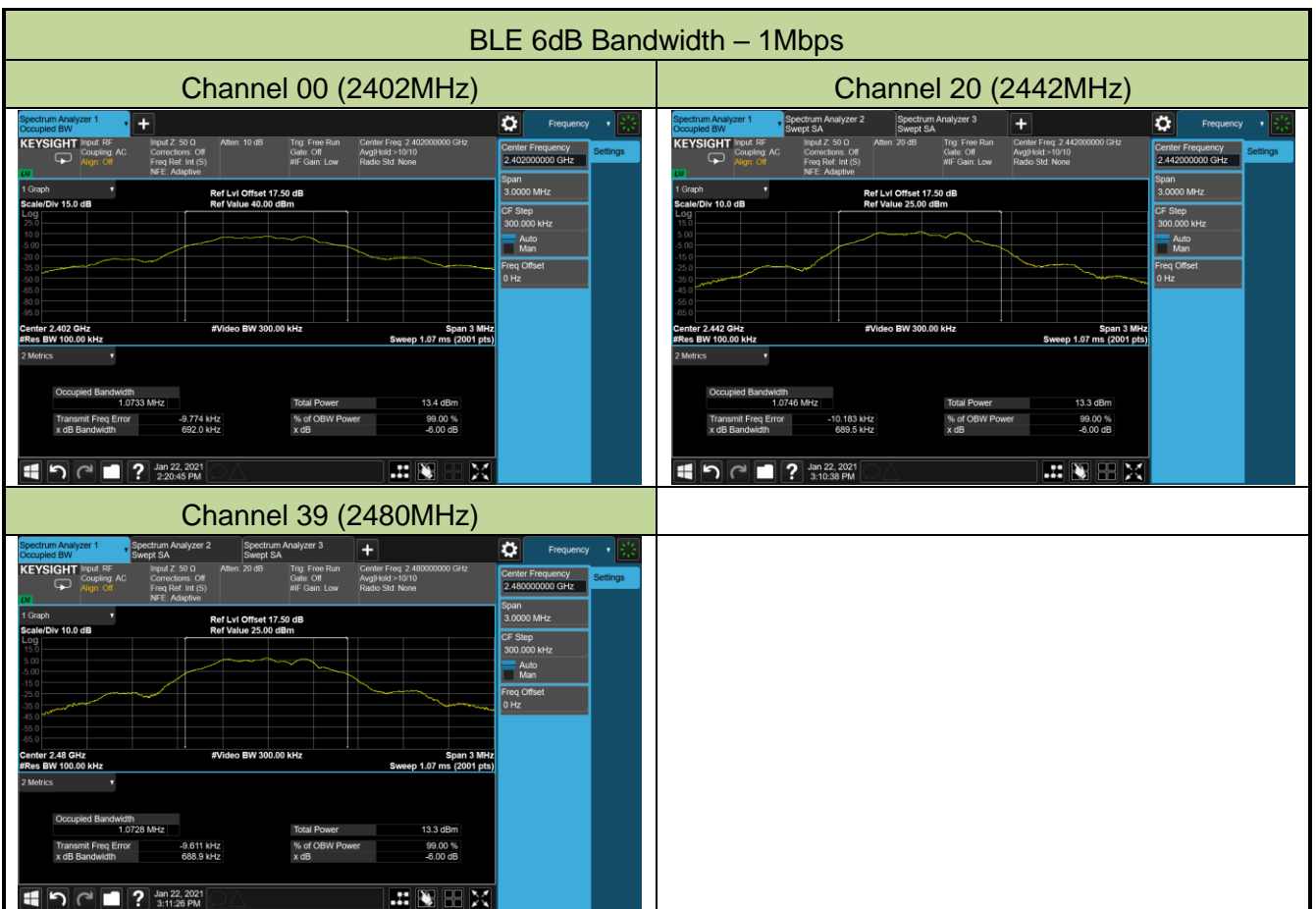

BLE 6dB Bandwidth – 2Mbps

Channel 00 (2402MHz)



Channel 20 (2442MHz)

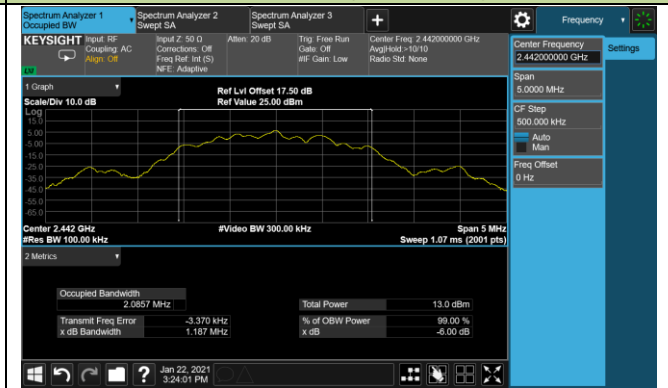

Channel 39 (2480MHz)

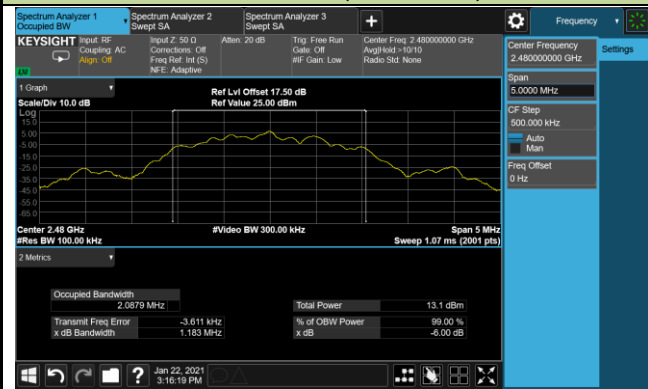

### **7.3. Output Power Measurement**

#### **7.3.1. Test Limit**

The maximum out power shall be less 1 Watt (30dBm).

The conducted output power limit specified in paragraph FCC Part 15.247(b) of this section is based on the use of antennas with directional gains that do not exceed 6 dBi. If transmitting antennas of directional gain greater than 6 dBi are used, the conducted output power from the intentional radiator shall be reduced below the stated values in paragraphs FCC Part 15.247(b)(3) of this section, as appropriate, by the amount in dB that the directional gain of the antenna exceeds 6 dBi.

#### **7.3.2. Test Procedure Used**

ANSI C63.10-2013 Section 11.9.1.3

ANSI C63.10-2013 Section 11.9.2.3

#### **7.3.3. Test Setting**

##### **Method PKPM1 (Peak Power Measurement of Signals with DTS BW $\leq$ 50MHz)**

Peak power measurements were performed only when the EUT was transmitting at its maximum power control level using a broadband power meter with a pulse sensor. The pulse sensor employs a VBW = 50MHz so this method was only used for signals whose DTS bandwidth was less than or equal to 50MHz.

##### **Average Power Measurement**

Average power measurements were performed only when the EUT was transmitting at its maximum power control level using a broadband power meter with a pulse sensor. The power meter implemented triggering and gating capabilities which were set up such that power measurements were recorded only during the ON time of the transmitter.

### 7.3.4. Test Setup

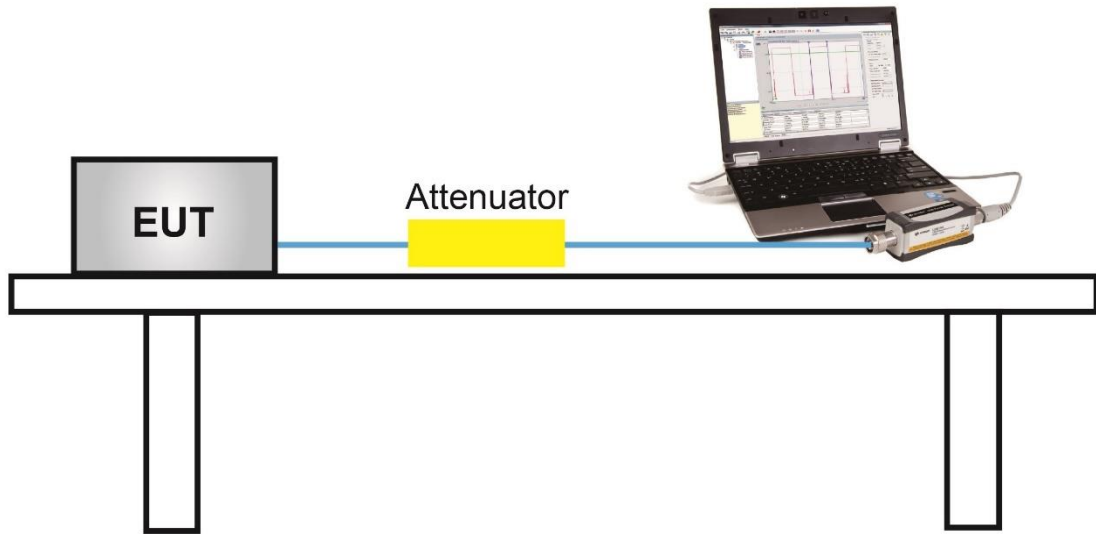

### 7.3.5. Test Result

Product	ACCESS POINT	Test Engineer	Eric Lin
Test Site	SR2	Test Date	2021/01/22
Filter Configuration	Filter 4#		

#### Test Result of Peak Output Power

Test Mode	Data Rate (Mbps)	Channel No.	Frequency (MHz)	Peak Power (dBm)	Limit (dBm)	Result
BLE	1	00	2402	6.60	≤ 30.00	Pass
BLE	1	20	2442	6.59	≤ 30.00	Pass
BLE	1	39	2480	6.51	≤ 30.00	Pass
BLE	2	00	2402	6.61	≤ 30.00	Pass
BLE	2	20	2442	6.59	≤ 30.00	Pass
BLE	2	39	2480	6.50	≤ 30.00	Pass

#### Test Result of Average Output Power (Reporting Only)

Test Mode	Data Rate (Mbps)	Channel No.	Frequency (MHz)	Average Power (dBm)	Limit (dBm)	Result
BLE	1	00	2402	6.52	≤ 30.00	Pass
BLE	1	20	2442	6.50	≤ 30.00	Pass
BLE	1	39	2480	6.42	≤ 30.00	Pass
BLE	2	00	2402	4.44	≤ 30.00	Pass
BLE	2	20	2442	4.47	≤ 30.00	Pass
BLE	2	39	2480	4.38	≤ 30.00	Pass



Product	ACCESS POINT	Test Engineer	Eric Lin
Test Site	SR2	Test Date	2021/01/22
Filter Configuration	Filter 5#		

**Test Result of Peak Output Power**

Test Mode	Data Rate (Mbps)	Channel No.	Frequency (MHz)	Peak Power (dBm)	Limit (dBm)	Result
BLE	1	00	2402	5.91	≤ 30.00	Pass
BLE	2	00	2402	5.93	≤ 30.00	Pass

**Test Result of Average Output Power (Reporting Only)**

Test Mode	Data Rate (Mbps)	Channel No.	Frequency (MHz)	Average Power (dBm)	Limit (dBm)	Result
BLE	1	00	2402	5.82	≤ 30.00	Pass
BLE	2	00	2402	3.79	≤ 30.00	Pass

Product	ACCESS POINT	Test Engineer	Eric Lin
Test Site	SR2	Test Date	2021/01/22
Filter Configuration	Filter 6#		

**Test Result of Peak Output Power**

Test Mode	Data Rate (Mbps)	Channel No.	Frequency (MHz)	Peak Power (dBm)	Limit (dBm)	Result
BLE	1	39	2480	4.46	≤ 30.00	Pass
BLE	2	39	2480	4.47	≤ 30.00	Pass

**Test Result of Average Output Power (Reporting Only)**

Test Mode	Data Rate (Mbps)	Channel No.	Frequency (MHz)	Average Power (dBm)	Limit (dBm)	Result
BLE	1	39	2480	4.33	≤ 30.00	Pass
BLE	2	39	2480	2.30	≤ 30.00	Pass

## 7.4. Power Spectral Density Measurement

### 7.4.1. Test Limit

The maximum permissible power spectral density is 8dBm in any 3 kHz band.

The same method of determining the conducted output power shall be used to determine the power spectral density.

### 7.4.2. Test Procedure Used

ANSI C63.10-2013 Section 11.10.2

### 7.4.3. Test Setting

1. Analyzer was set to the center frequency of the DTS channel under investigation
2. Span = 1.5 times the DTS channel bandwidth
3. RBW = 3kHz
4. VBW = 10kHz
5. Detector = peak
6. Sweep time = auto couple
7. Trace mode = max hold
8. Trace was allowed to stabilize

### 7.4.4. Test Setup

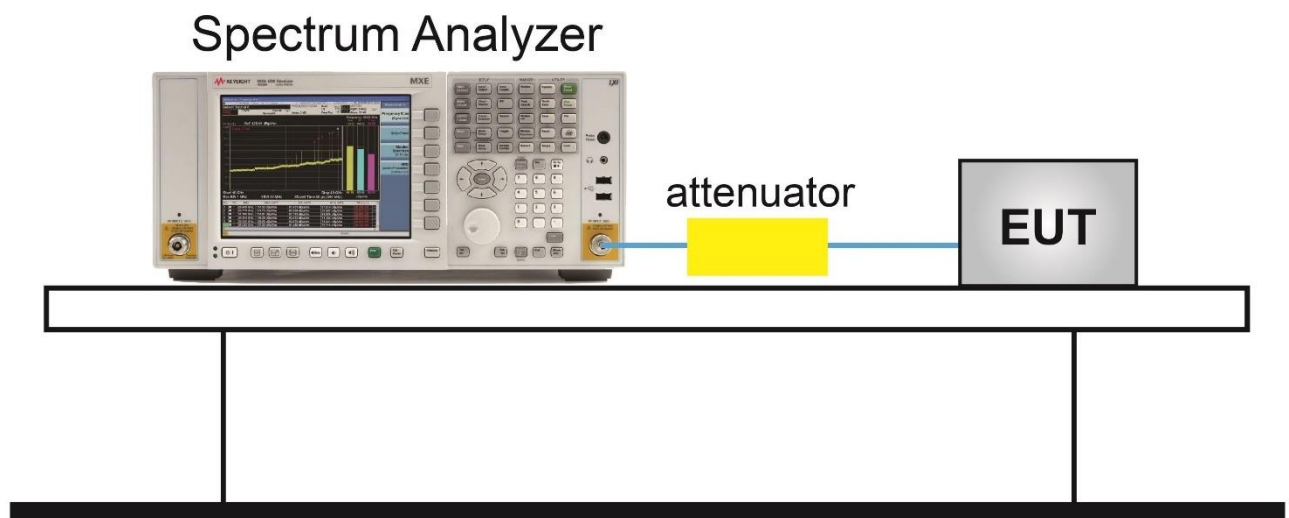

### 7.4.5. Test Result

Product	ACCESS POINT	Test Engineer	Eric Lin
Test Site	SR2	Test Date	2021/01/22

Test Mode	Data Rate (Mbps)	Channel No.	Frequency (MHz)	PSD Result (dBm / 3kHz)	Limit (dBm / 3kHz)	Result
BLE	1	00	2402	-10.37	≤ 8.00	Pass
BLE	1	20	2442	-10.46	≤ 8.00	Pass
BLE	1	39	2480	-10.57	≤ 8.00	Pass
BLE	2	00	2402	-13.48	≤ 8.00	Pass
BLE	2	20	2442	-13.32	≤ 8.00	Pass
BLE	2	39	2480	-13.26	≤ 8.00	Pass

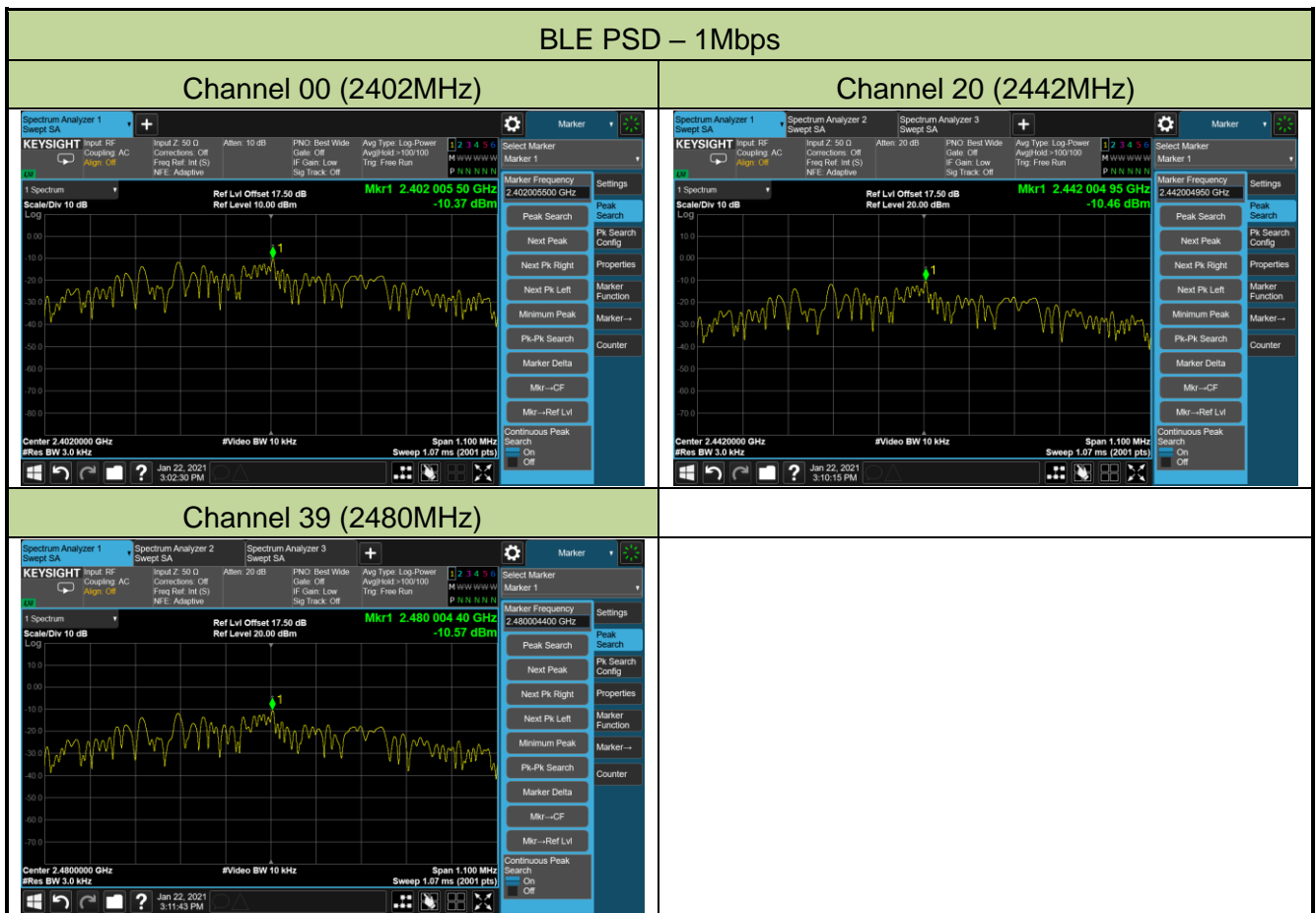

### BLE PSD – 2Mbps

#### Channel 00 (2402MHz)



#### Channel 20 (2442MHz)

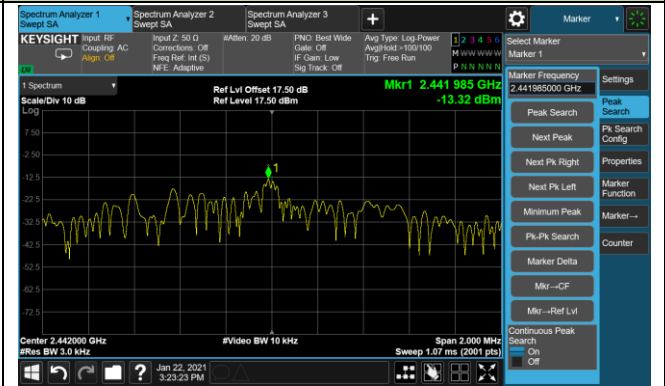

#### Channel 39 (2480MHz)



## **7.5. Conducted Band Edge and Out-of-Band Emissions**

### **7.5.1. Test Limit**

The limit for out-of-band spurious emissions at the band edge is 20dB below the fundamental emission level, as determined from the in-band power measurement of the DTS channel performed in a 100kHz bandwidth per the PSD procedure.

### **7.5.2. Test Procedure Used**

ANSI C63.10-2013 Section 11.11

### **7.5.3. Test Setting**

#### **1. Reference level measurement**

- a) Set instrument center frequency to DTS channel center frequency
- b) Set the span to  $\geq 1.5$  times the DTS bandwidth
- c) Set the RBW = 100 kHz
- d) Set the VBW  $\geq 3 \times$  RBW
- e) Detector = peak
- f) Sweep time = auto couple
- g) Trace mode = max hold
- h) Allow trace to fully stabilize

#### **2. Emission level measurement**

- a) Start frequency was set to 30MHz and stop frequency was set to 25GHz (separated into two plots per channel)
- b) RBW = 100kHz
- c) VBW = 300kHz
- d) Detector = Peak
- e) Trace mode = max hold
- f) Sweep time = auto couple
- g) The trace was allowed to stabilize

### 7.5.4. Test Setup

## Spectrum Analyzer

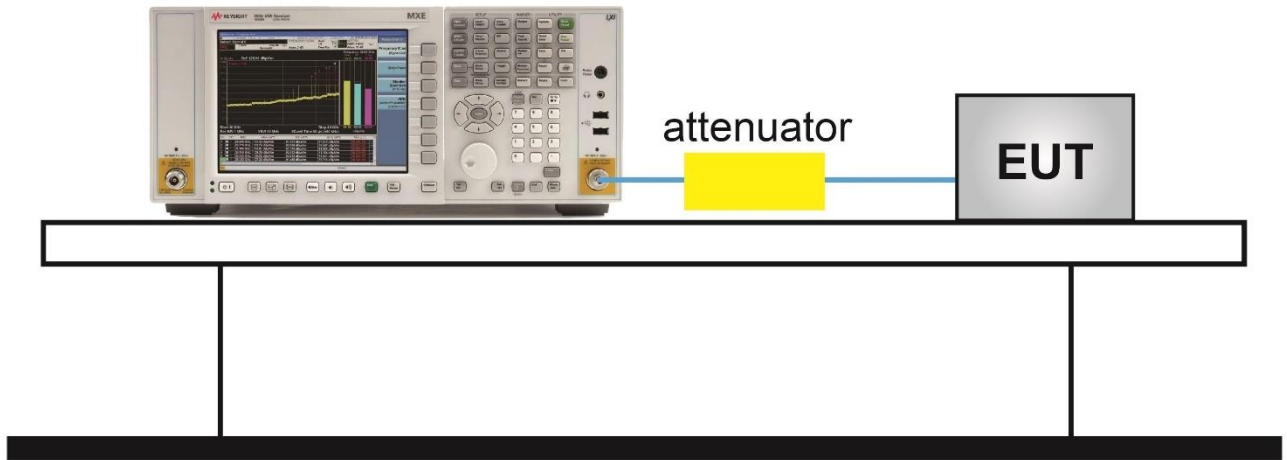

### 7.5.5. Test Result

Product	ACCESS POINT	Test Engineer	Eric Lin
Test Site	SR2	Test Date	2021/01/22
Filter Configuration	Filter 4#		

Test Mode	Data Rate (Mbps)	Channel No.	Frequency (MHz)	Limit	Result
BLE	1	00	2402	20dBc	Pass
BLE	1	20	2442	20dBc	Pass
BLE	1	39	2480	20dBc	Pass
BLE	2	00	2402	20dBc	Pass
BLE	2	20	2442	20dBc	Pass
BLE	2	39	2480	20dBc	Pass

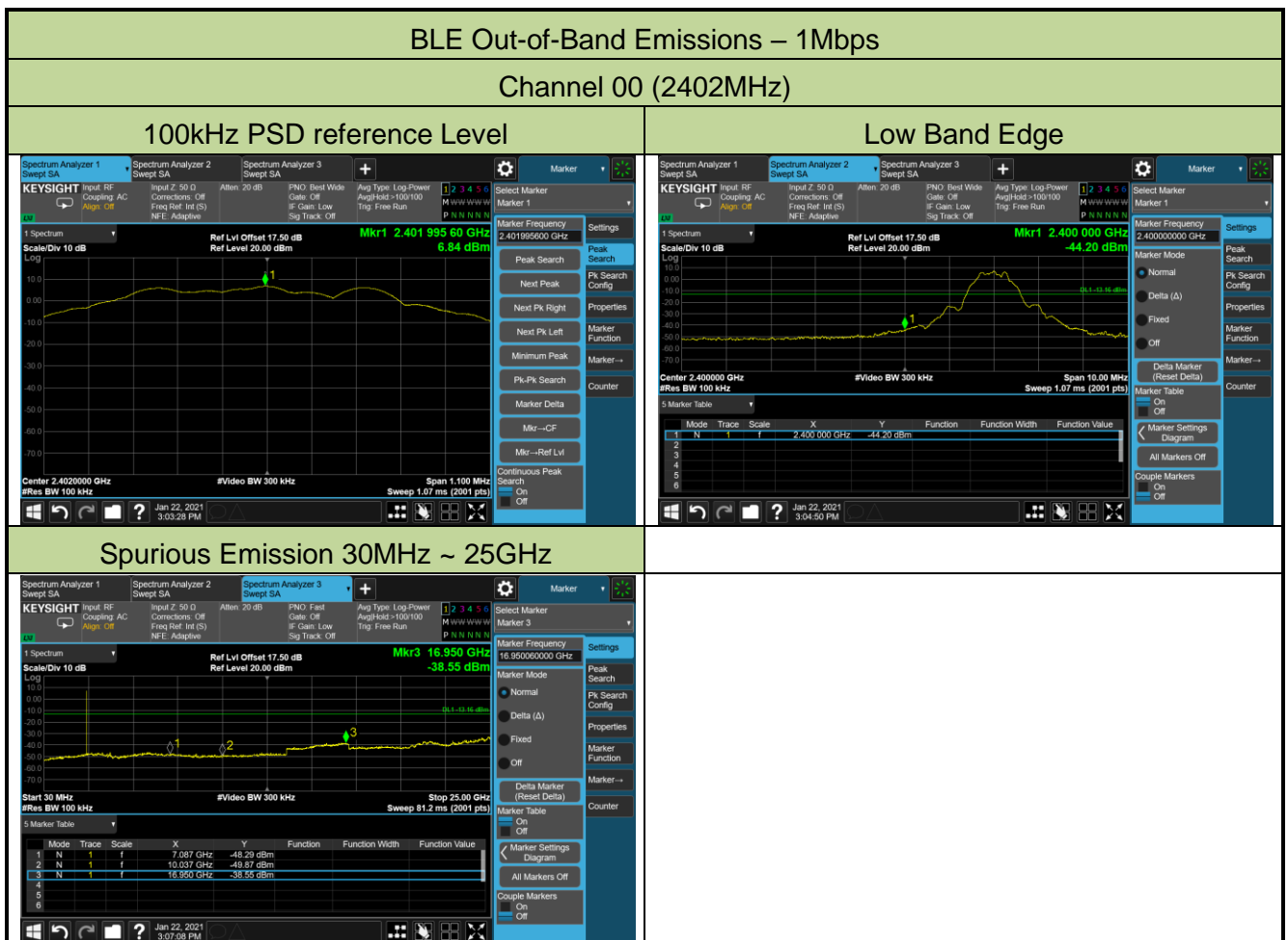

**Channel 20 (2442MHz)**

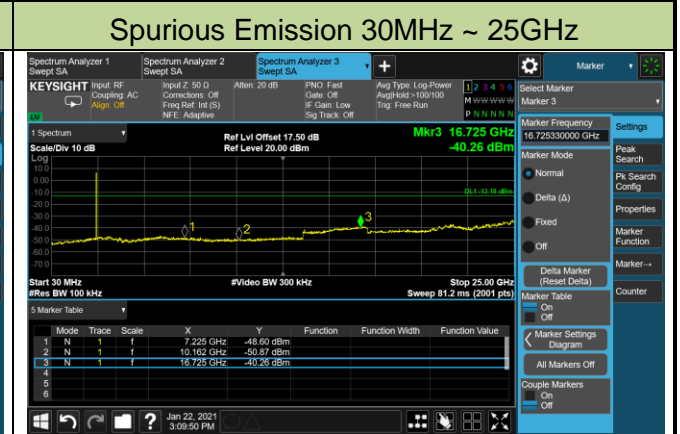
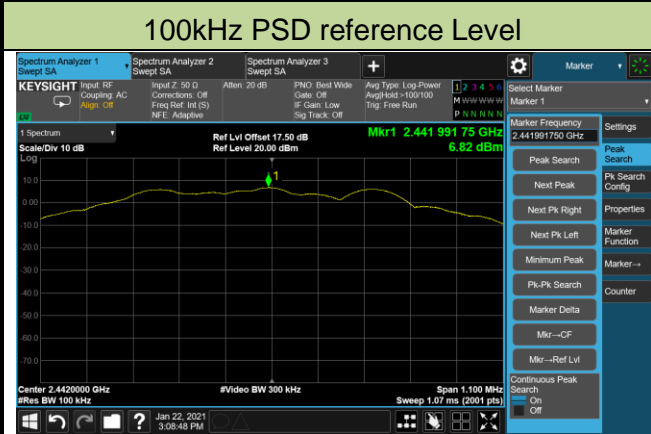

**Channel 39 (2480MHz)**

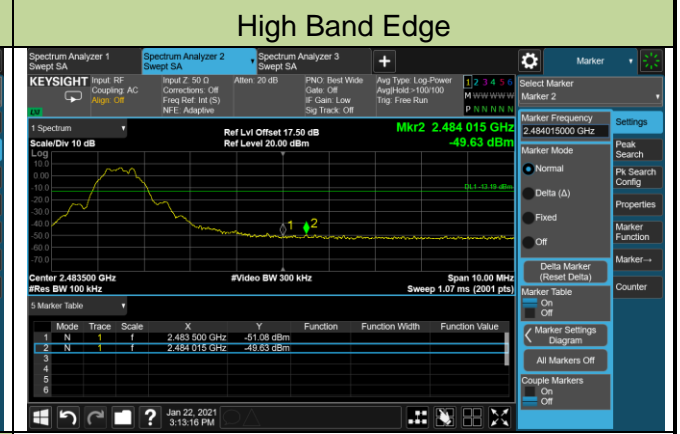
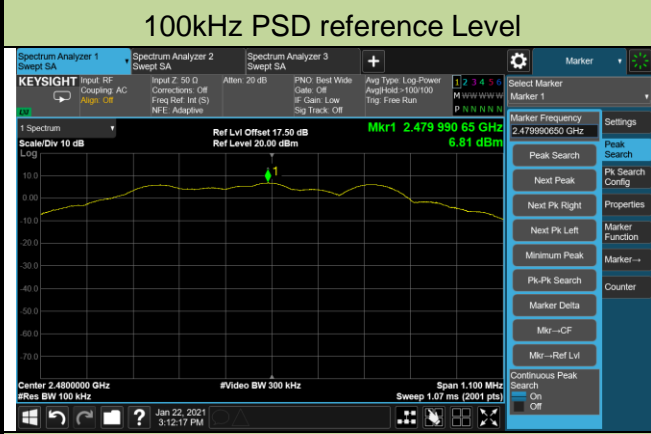

**Spurious Emission 30MHz ~ 25GHz**

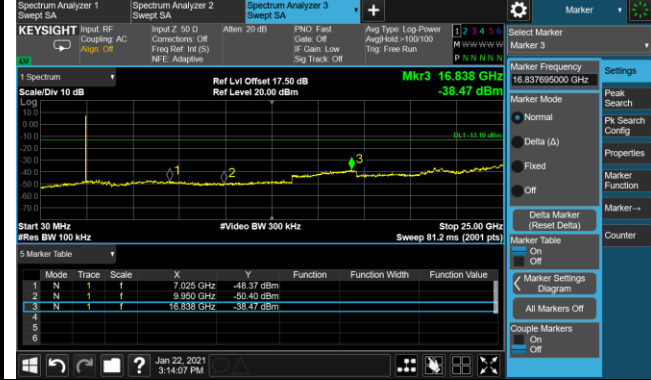



### BLE Out-of-Band Emissions – 2Mbps

#### Channel 00 (2402MHz)

##### 100kHz PSD reference Level

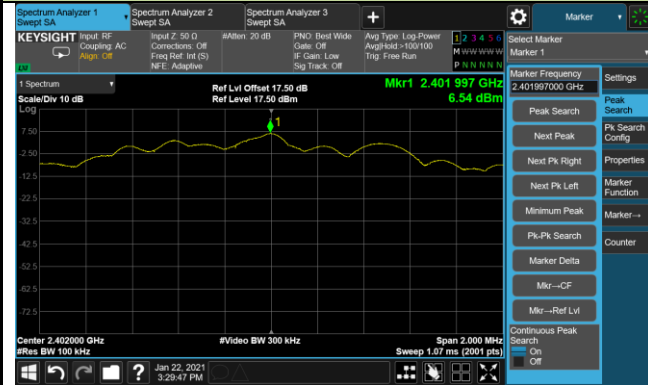

##### Low Band Edge

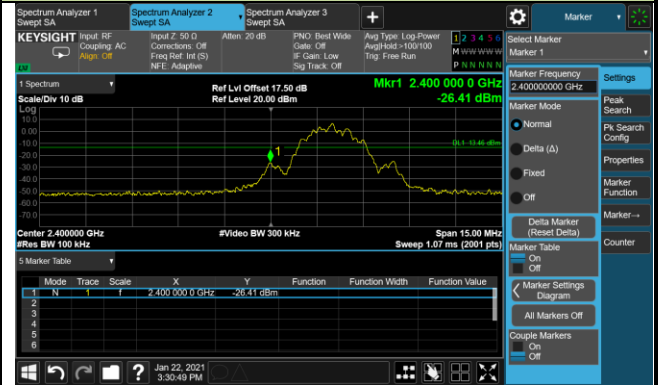

##### Spurious Emission 30MHz ~ 25GHz

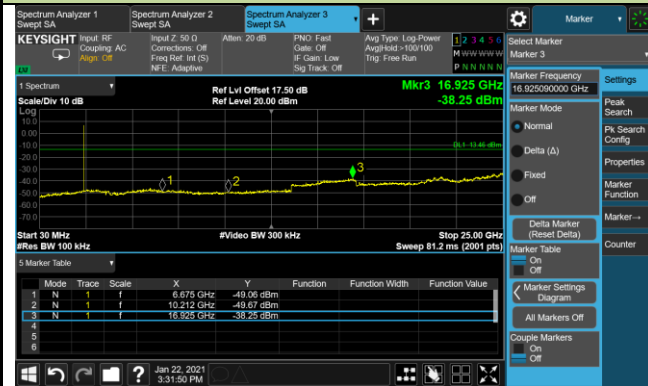

#### Channel 20 (2442MHz)

##### 100kHz PSD reference Level

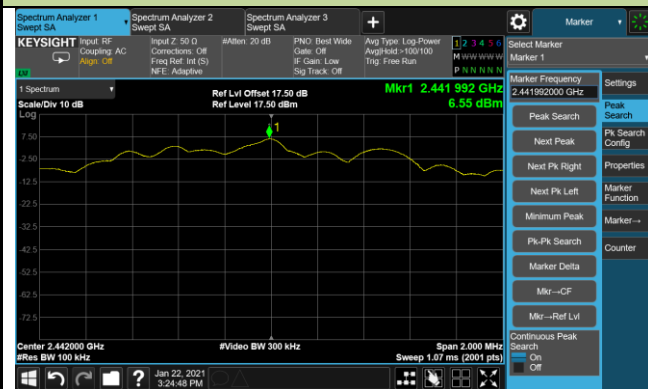

##### Spurious Emission 30MHz ~ 25GHz

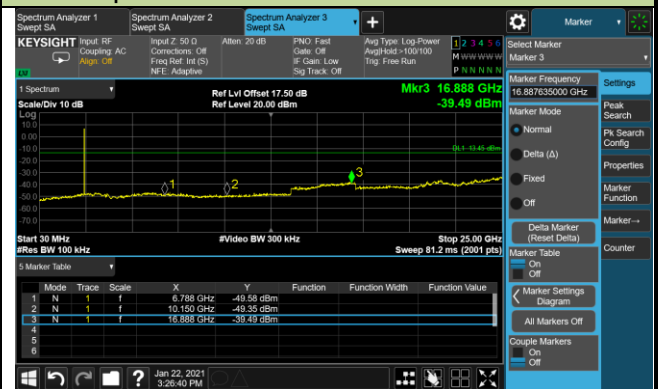

### Channel 39 (2480MHz)

#### 100kHz PSD reference Level

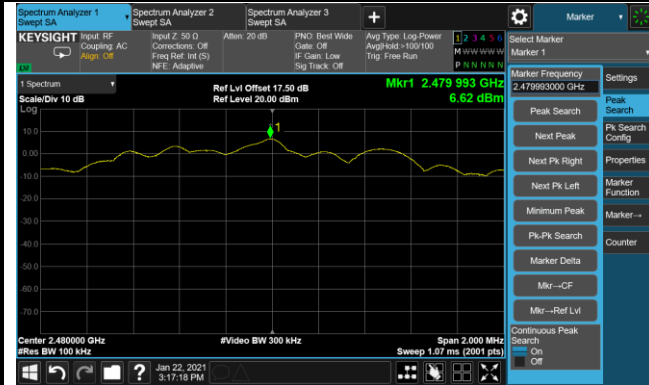

#### High Band Edge

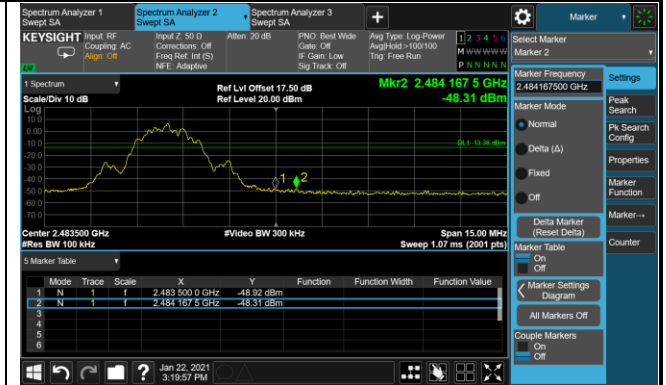

#### Spurious Emission 30MHz ~ 25GHz

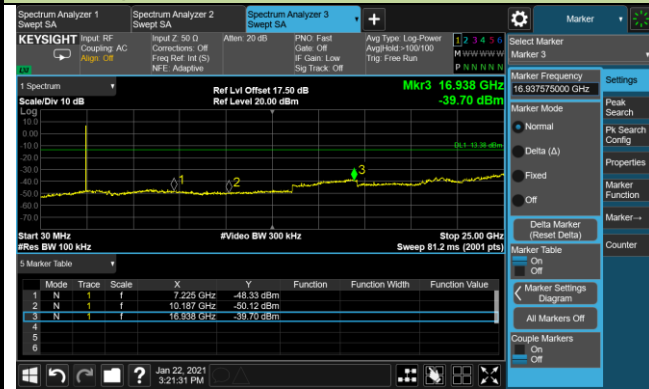

Product	ACCESS POINT	Test Engineer	Eric Lin
Test Site	SR2	Test Date	2021/05/08
Filter Configuration	Filter 5#		

Test Mode	Data Rate (Mbps)	Channel No.	Frequency (MHz)	Limit	Result
BLE	2	00	2402	20dBc	Pass



Product	ACCESS POINT	Test Engineer	Eric Lin
Test Site	SR2	Test Date	2021/05/08
Filter Configuration	Filter 6#		

Test Mode	Data Rate (Mbps)	Channel No.	Frequency (MHz)	Limit	Result
BLE	2	39	2480	20dBc	Pass

**Out-of-Band Emissions Worst Case - 2Mbps**  
Channel 39 (2480MHz)

**100kHz PSD reference Level**



**Low Band Edge**



**Spurious Emission 30MHz ~ 25GHz**

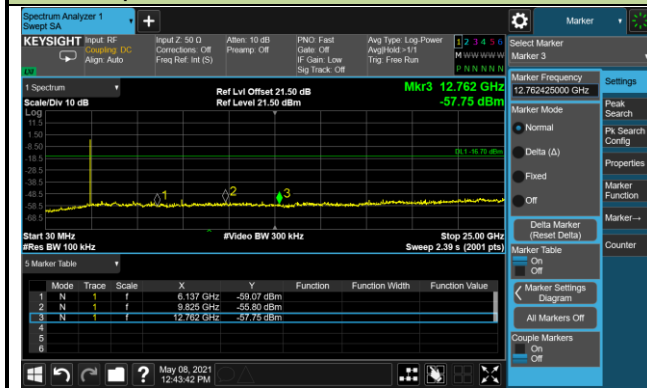

## 7.6. Radiated Spurious Emission Measurement

### 7.6.1. Test Limit

All out of band emissions appearing in a restricted band as specified in Section 15.205 of the Title 47 CFR must not exceed the limits shown in Table per Section 15.209.

FCC Part 15 Subpart C Paragraph 15.209		
Frequency [MHz]	Field Strength [uV/m]	Measured Distance [Meters]
0.009 - 0.490	2400/F (kHz)	300
0.490 - 1.705	24000/F (kHz)	30
1.705 - 30	30	30
30 - 88	100	3
88 - 216	150	3
216 - 960	200	3
Above 960	500	3

### 7.6.2. Test Procedure Used

ANSI C63.10-2013 Section 6.3 (General Requirements)

ANSI C63.10-2013 Section 6.4 (Standard test method below 30MHz)

ANSI C63.10-2013 Section 6.5 (Standard test method above 30MHz to 1GHz)

ANSI C63.10-2013 Section 6.6 (Standard test method above 1GHz)

ANSI C63.10-2013 Section 11.11 & 11.12

### 7.6.3. Test Setting

**Table 1 - RBW as a function of frequency**

Frequency	RBW
9 ~ 150 kHz	200 ~ 300 Hz
0.15 ~ 30 MHz	9 ~ 10 kHz
30 ~ 1000 MHz	100 ~ 120 kHz

**Quasi-Peak Measurements below 1GHz**

1. Analyzer center frequency was set to the frequency of the radiated spurious emission of interest
2. Span was set greater than 1MHz
3. RBW = as specified in Table 1
4. Detector = CISPR quasi-peak
5. Sweep time = auto couple
6. Trace was allowed to stabilize

**Peak Measurements above 1GHz**

1. Analyzer center frequency was set to the frequency of the radiated spurious emission of interest
2. RBW = 1MHz
3. VBW = 3MHz
4. Detector = peak
5. Sweep time = auto couple
6. Trace mode = max hold
7. Trace was allowed to stabilize

**Average Measurements above 1GHz**

1. Analyzer center frequency was set to the frequency of the radiated spurious emission of interest
2. RBW = 1MHz
3. VBW =  $1 / T$ , (For 1Mbps, VBW = 10kHz; For 2Mbps, VBW = 20kHz)
4. Average Type = Voltage
5. Detector = Peak
6. Sweep time = auto
7. Trace mode = max hold
8. Trace was allowed to stabilize

### 7.6.4. Test Setup

#### Below 1GHz Test Setup:

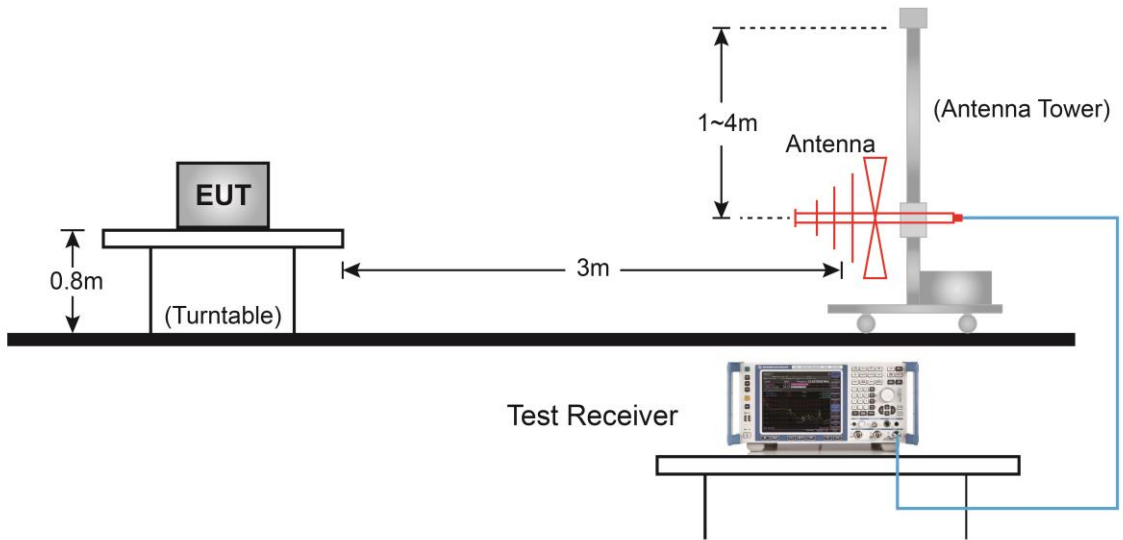

#### Above 1GHz Test Setup:

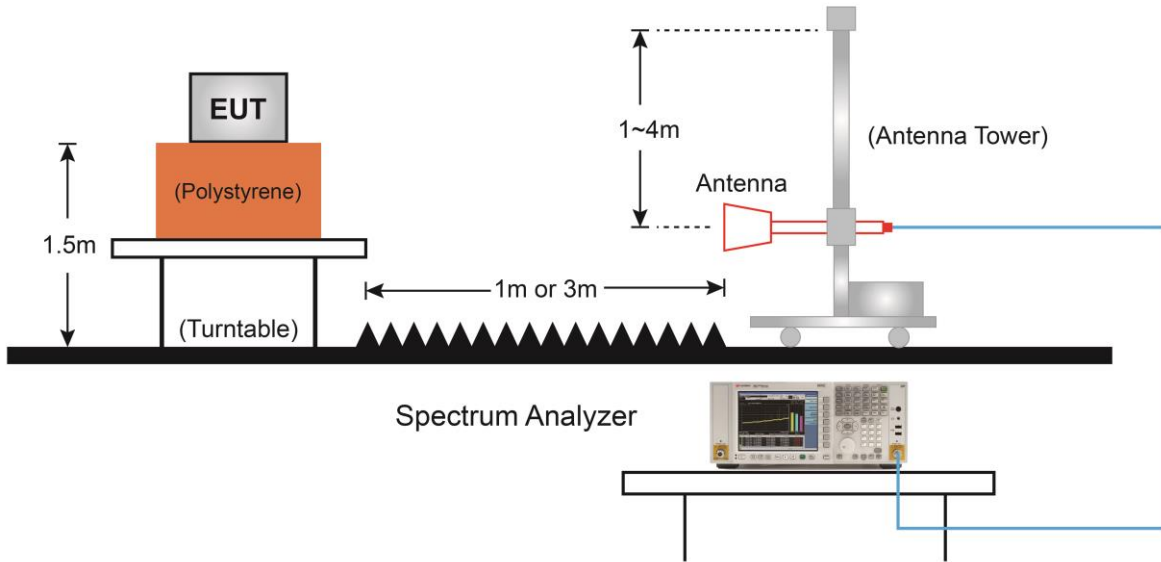

### 7.6.5. Test Result

#### Filter Configuration 4#

EUT	ACCESS POINT	Date of Test	2021-03-10
Factor	BBHA 9120D	Temp. / Humidity	20.8°C/35%
Polarity	Horizontal	Site / Test Engineer	AC1 / Jay Chu
Test Mode	Transmit by BLE at Channel 2402MHz - 1Mbps	Test Voltage	120V/60Hz

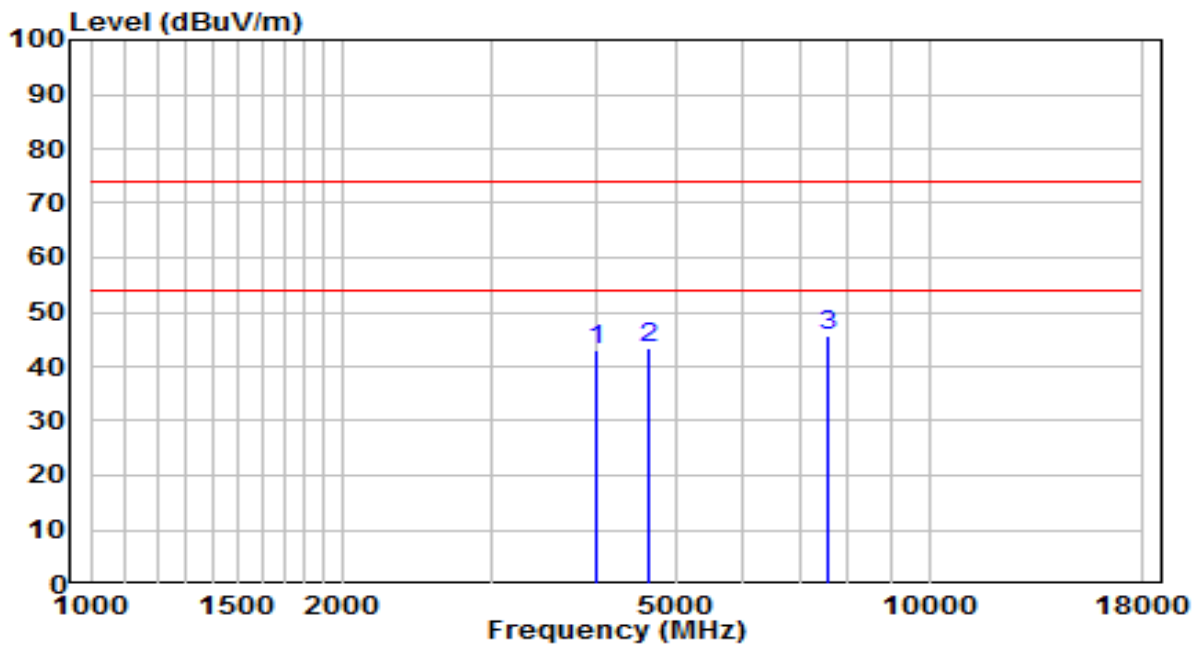

No	Frequency (MHz)	Reading (dBuV)	C.F (dB)	Measurement (dBuV/m)	Margin (dB)	Limit (dBuV/m)	Remark (QP/PK/AV)
1	4009.000	42.27	0.91	43.18	-30.82	74.00	Peak
2	4638.000	40.40	2.88	43.28	-30.72	74.00	Peak
3	* 7562.000	33.87	11.82	45.69	-28.31	74.00	Peak

Note:

1. " \*", means this data is the worst emission level.
2. C.F (Correction Factor) = Antenna Factor (dB) + Cable Loss (dB)– Preamplifier(dB).
3. Measurement(dBuV/m) = Reading(dBuV) + C.F (Correction Factor).
4. The emission levels of other frequencies are very lower than the limit and not show in test report.



EUT	ACCESS POINT	Date of Test	2021-03-10
Factor	BBHA 9120D	Temp. / Humidity	20.8°C/35%
Polarity	Vertical	Site / Test Engineer	AC1 / Jay Chu
Test Mode	Transmit by BLE at Channel 2402MHz - 1Mbps	Test Voltage	120V/60Hz

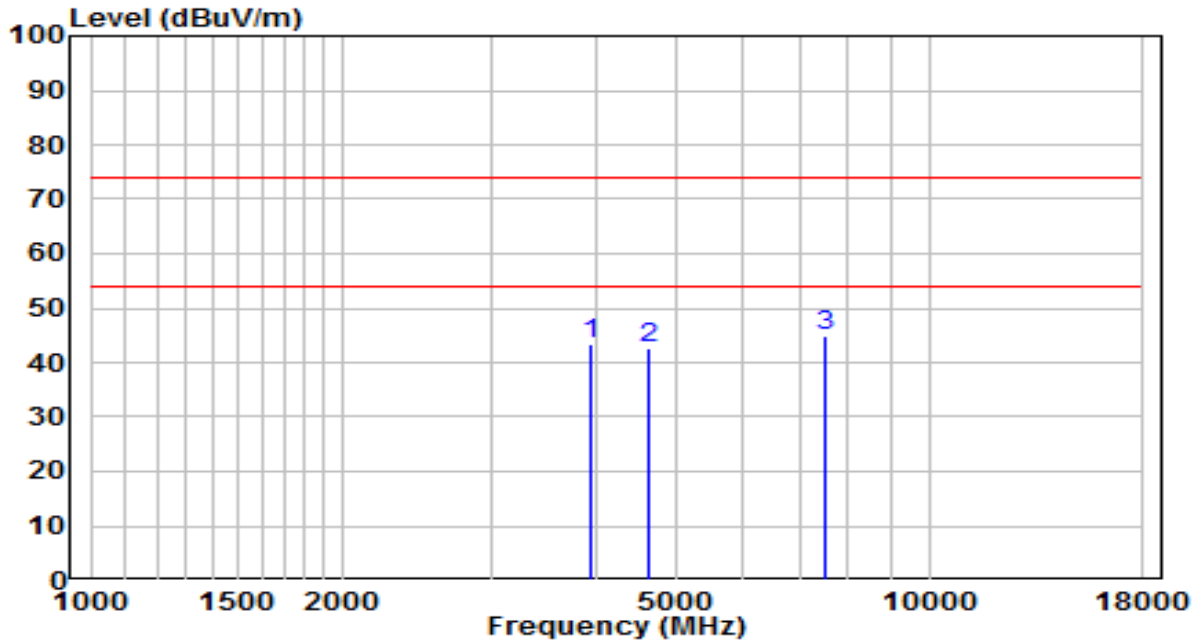

No	Frequency (MHz)	Reading (dBuV)	C.F (dB)	Measurement (dBuV/m)	Margin (dB)	Limit (dBuV/m)	Remark (QP/PK/AV)
1	3958.000	42.71	0.74	43.44	-30.56	74.00	Peak
2	4638.000	39.86	2.88	42.74	-31.26	74.00	Peak
3	* 7528.000	33.22	11.76	44.98	-29.02	74.00	Peak

Note:

- "\*", means this data is the worst emission level.
- C.F (Correction Factor) = Antenna Factor (dB) + Cable Loss (dB) – Pre-amplifier(dB).
- Measurement(dBuV/m) = Reading(dBuV) + C.F (Correction Factor).
- The emission levels of other frequencies are very lower than the limit and not show in test report.

EUT	ACCESS POINT	Date of Test	2021-03-10
Factor	BBHA 9120D	Temp. / Humidity	20.8°C/35%
Polarity	Horizontal	Site / Test Engineer	AC1 / Jay Chu
Test Mode	Transmit by BLE at Channel 2442MHz - 1Mbps	Test Voltage	120V/60Hz

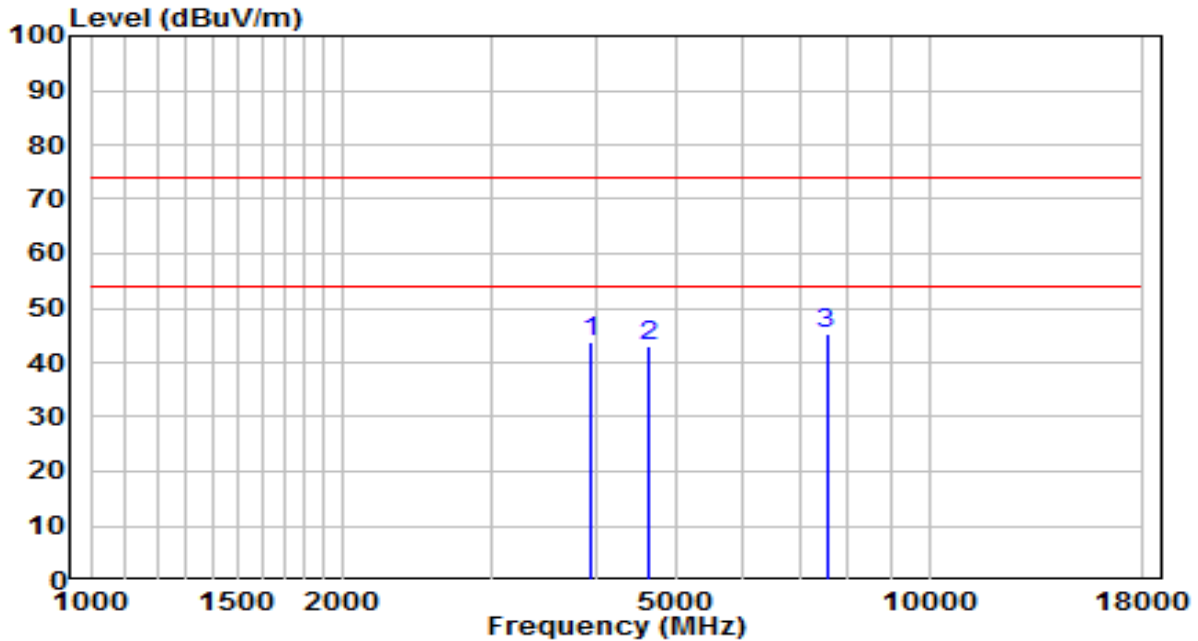

No	Frequency (MHz)	Reading (dBuV)	C.F (dB)	Measurement (dBuV/m)	Margin (dB)	Limit (dBuV/m)	Remark (QP/PK/AV)
1	3958.000	43.09	0.74	43.83	-30.17	74.00	Peak
2	4621.000	40.18	2.84	43.02	-30.98	74.00	Peak
3	* 7545.000	33.58	11.79	45.37	-28.63	74.00	Peak

Note:

- "\*", means this data is the worst emission level.
- C.F (Correction Factor) = Antenna Factor (dB) + Cable Loss (dB) – Pre-amplifier(dB).
- Measurement(dBuV/m) = Reading(dBuV) + C.F (Correction Factor).
- The emission levels of other frequencies are very lower than the limit and not show in test report.

EUT	ACCESS POINT	Date of Test	2021-03-10
Factor	BBHA 9120D	Temp. / Humidity	20.8°C/35%
Polarity	Vertical	Site / Test Engineer	AC1 / Jay Chu
Test Mode	Transmit by BLE at Channel 2442MHz - 1Mbps	Test Voltage	120V/60Hz

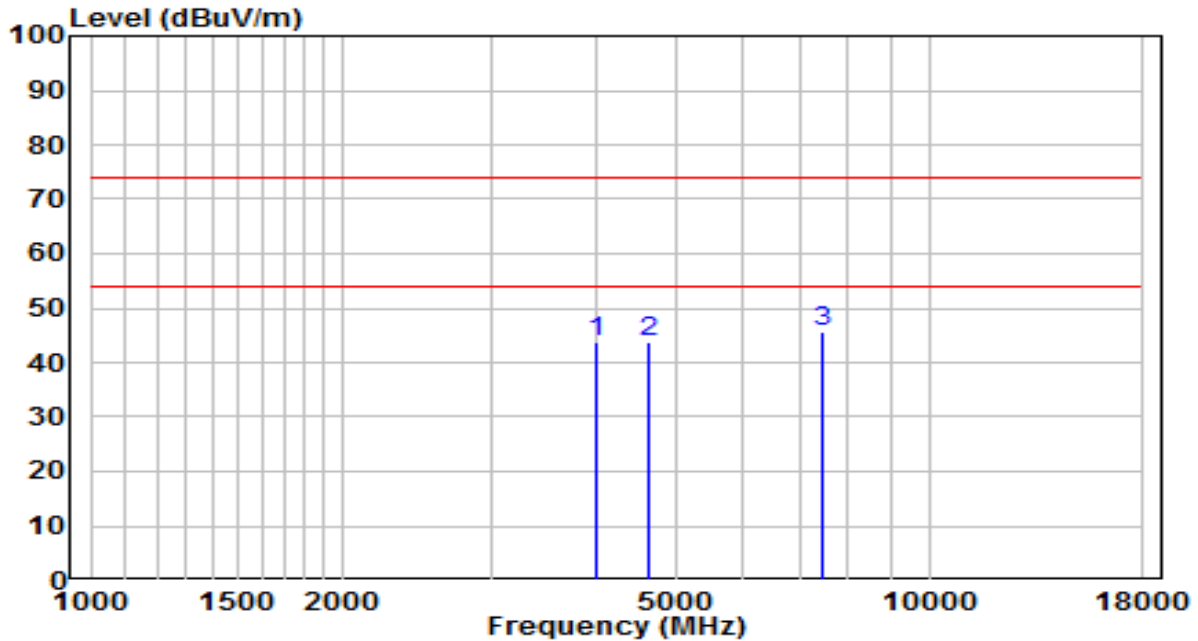

No	Frequency (MHz)	Reading (dBuV)	C.F (dB)	Measurement (dBuV/m)	Margin (dB)	Limit (dBuV/m)	Remark (QP/PK/AV)
1	4009.000	42.75	0.91	43.66	-30.34	74.00	Peak
2	4621.000	40.94	2.84	43.78	-30.22	74.00	Peak
3	* 7477.000	33.83	11.65	45.48	-28.52	74.00	Peak

Note:

1. " \*", means this data is the worst emission level.
2. C.F (Correction Factor) = Antenna Factor (dB) + Cable Loss (dB)– Pre-amplifier(dB).
3. Measurement(dBuV/m) = Reading(dBuV) + C.F (Correction Factor).
4. The emission levels of other frequencies are very lower than the limit and not show in test report.

EUT	ACCESS POINT	Date of Test	2021-03-10
Factor	BBHA 9120D	Temp. / Humidity	20.8°C/35%
Polarity	Horizontal	Site / Test Engineer	AC1 / Jay Chu
Test Mode	Transmit by BLE at Channel 2480MHz – 1Mbps	Test Voltage	120V/60Hz

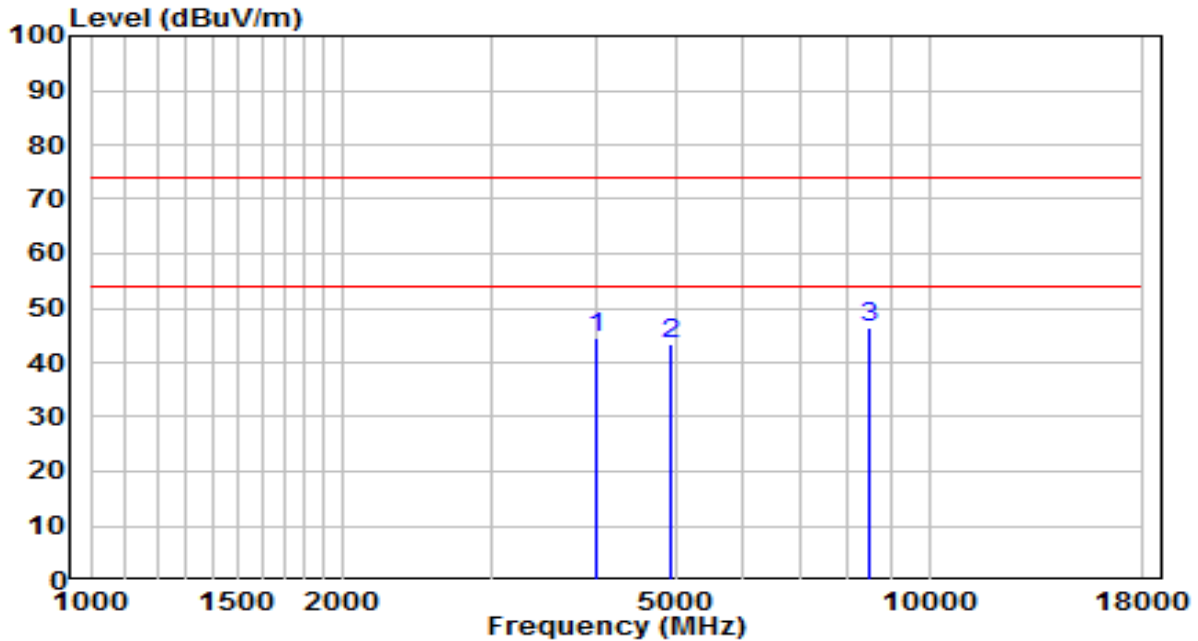

No	Frequency (MHz)	Reading (dBuV)	C.F (dB)	Measurement (dBuV/m)	Margin (dB)	Limit (dBuV/m)	Remark (QP/PK/AV)
1	4009.000	43.51	0.91	44.42	-29.58	74.00	Peak
2	4910.000	39.75	3.53	43.28	-30.72	74.00	Peak
3	* 8480.000	34.12	12.46	46.58	-27.42	74.00	Peak

Note:

1. " \*", means this data is the worst emission level.
2. C.F (Correction Factor) = Antenna Factor (dB) + Cable Loss (dB)– Pre-amplifier(dB).
3. Measurement(dBuV/m) = Reading(dBuV) + C.F (Correction Factor).
4. The emission levels of other frequencies are very lower than the limit and not show in test report.

EUT	ACCESS POINT	Date of Test	2021-03-10
Factor	BBHA 9120D	Temp. / Humidity	20.8°C/35%
Polarity	Vertical	Site / Test Engineer	AC1 / Jay Chu
Test Mode	Transmit by BLE at Channel 2480MHz – 1Mbps	Test Voltage	120V/60Hz

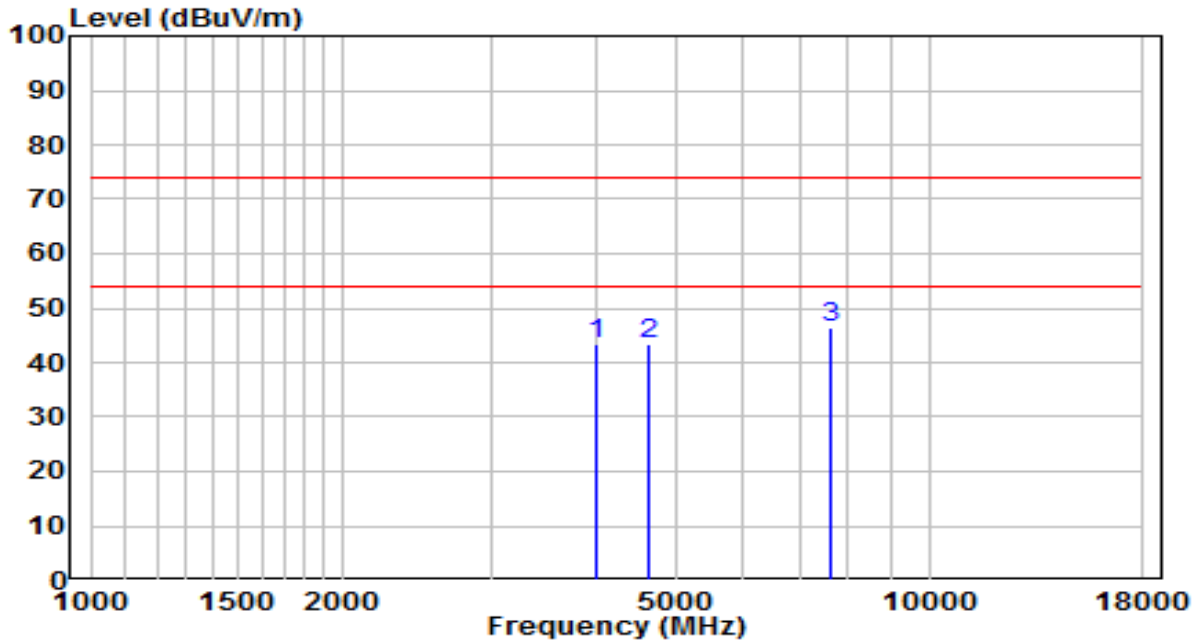

No	Frequency (MHz)	Reading (dBuV)	C.F (dB)	Measurement (dBuV/m)	Margin (dB)	Limit (dBuV/m)	Remark (QP/PK/AV)
1	4009.000	42.53	0.91	43.44	-30.56	74.00	Peak
2	4638.000	40.58	2.88	43.46	-30.54	74.00	Peak
3	* 7613.000	34.45	11.90	46.35	-27.65	74.00	Peak

Note:

1. " \*", means this data is the worst emission level.
2. C.F (Correction Factor) = Antenna Factor (dB) + Cable Loss (dB)– Pre-amplifier(dB).
3. Measurement(dBuV/m) = Reading(dBuV) + C.F (Correction Factor).
4. The emission levels of other frequencies are very lower than the limit and not show in test report.

EUT	ACCESS POINT	Date of Test	2021-03-10
Factor	BBHA 9120D	Temp. / Humidity	20.8°C/35%
Polarity	Horizontal	Site / Test Engineer	AC1 / Jay Chu
Test Mode	Transmit by BLE at Channel 2402MHz – 2Mbps	Test Voltage	120V/60Hz

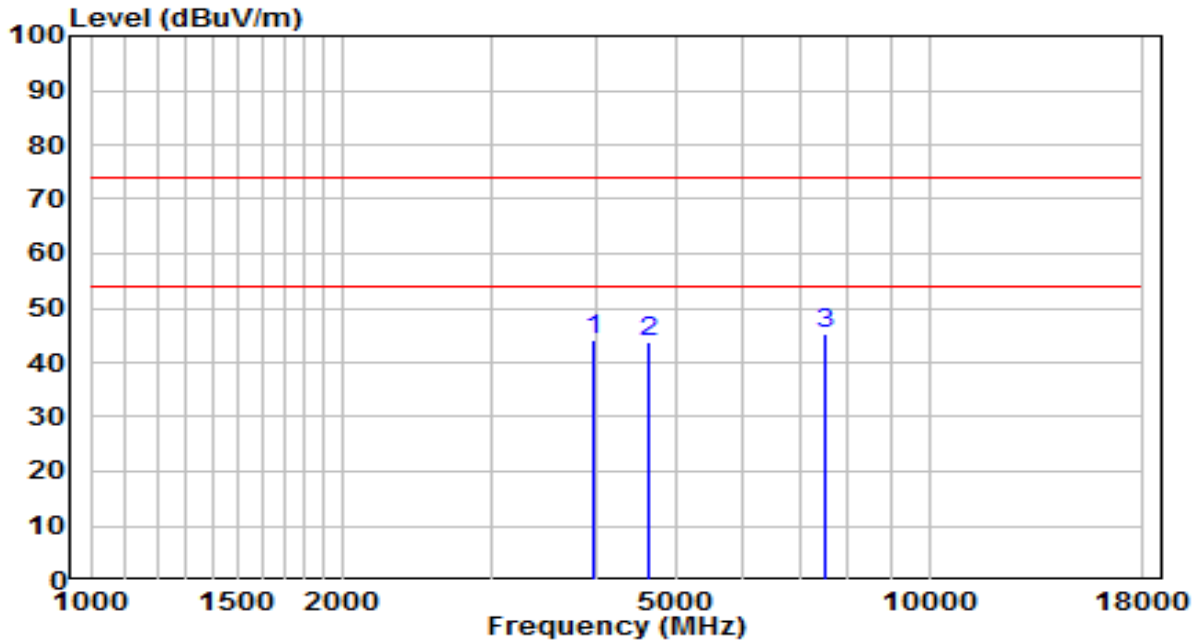

No	Frequency (MHz)	Reading (dBuV)	C.F (dB)	Measurement (dBuV/m)	Margin (dB)	Limit (dBuV/m)	Remark (QP/PK/AV)
1	3975.000	43.49	0.79	44.29	-29.71	74.00	Peak
2	4638.000	40.84	2.88	43.72	-30.28	74.00	Peak
3	* 7511.000	33.68	11.73	45.41	-28.59	74.00	Peak

Note:

1. " \*", means this data is the worst emission level.
2. C.F (Correction Factor) = Antenna Factor (dB) + Cable Loss (dB)– Pre-amplifier(dB).
3. Measurement(dBuV/m) = Reading(dBuV) + C.F (Correction Factor).
4. The emission levels of other frequencies are very lower than the limit and not show in test report.

EUT	ACCESS POINT	Date of Test	2021-03-10
Factor	BBHA 9120D	Temp. / Humidity	20.8°C/35%
Polarity	Vertical	Site / Test Engineer	AC1 / Jay Chu
Test Mode	Transmit by BLE at Channel 2402MHz – 2Mbps	Test Voltage	120V/60Hz

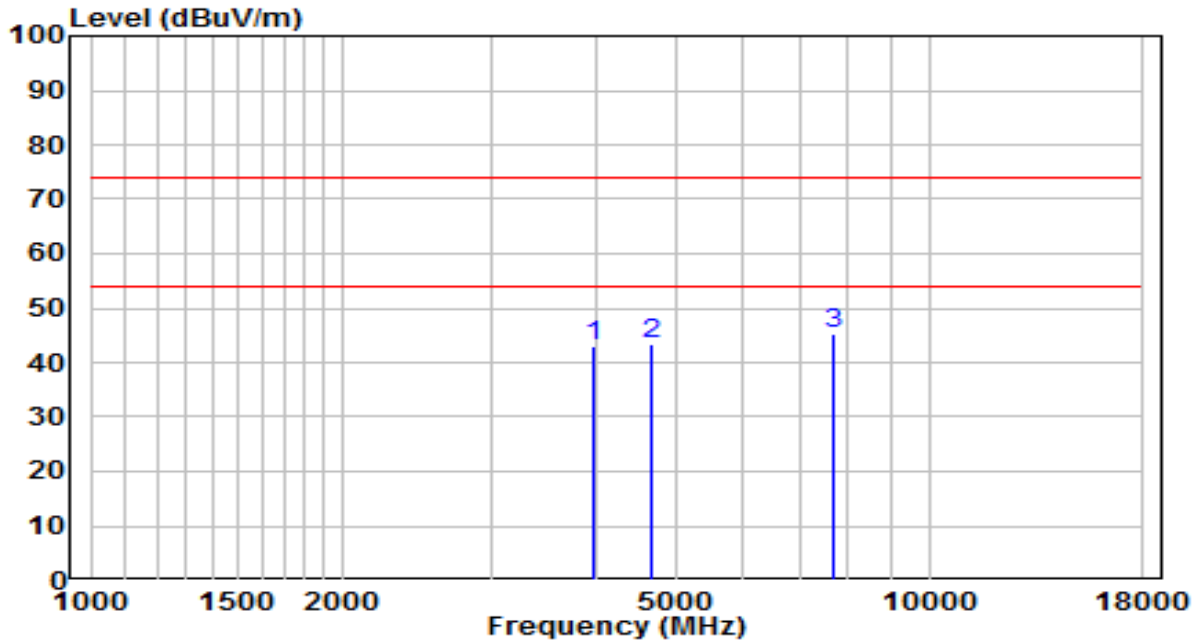

No	Frequency (MHz)	Reading (dBuV)	C.F (dB)	Measurement (dBuV/m)	Margin (dB)	Limit (dBuV/m)	Remark (QP/PK/AV)
1	3992.000	42.18	0.85	43.03	-30.97	74.00	Peak
2	4655.000	40.48	2.92	43.40	-30.60	74.00	Peak
3	* 7664.000	33.43	11.98	45.41	-28.59	74.00	Peak

Note:

- "\*", means this data is the worst emission level.
- C.F (Correction Factor) = Antenna Factor (dB) + Cable Loss (dB) – Pre-amplifier(dB).
- Measurement(dBuV/m) = Reading(dBuV) + C.F (Correction Factor).
- The emission levels of other frequencies are very lower than the limit and not show in test report.

EUT	ACCESS POINT	Date of Test	2021-03-10
Factor	BBHA 9120D	Temp. / Humidity	20.8°C/35%
Polarity	Horizontal	Site / Test Engineer	AC1 / Jay Chu
Test Mode	Transmit by BLE at Channel 2442MHz – 2Mbps	Test Voltage	120V/60Hz

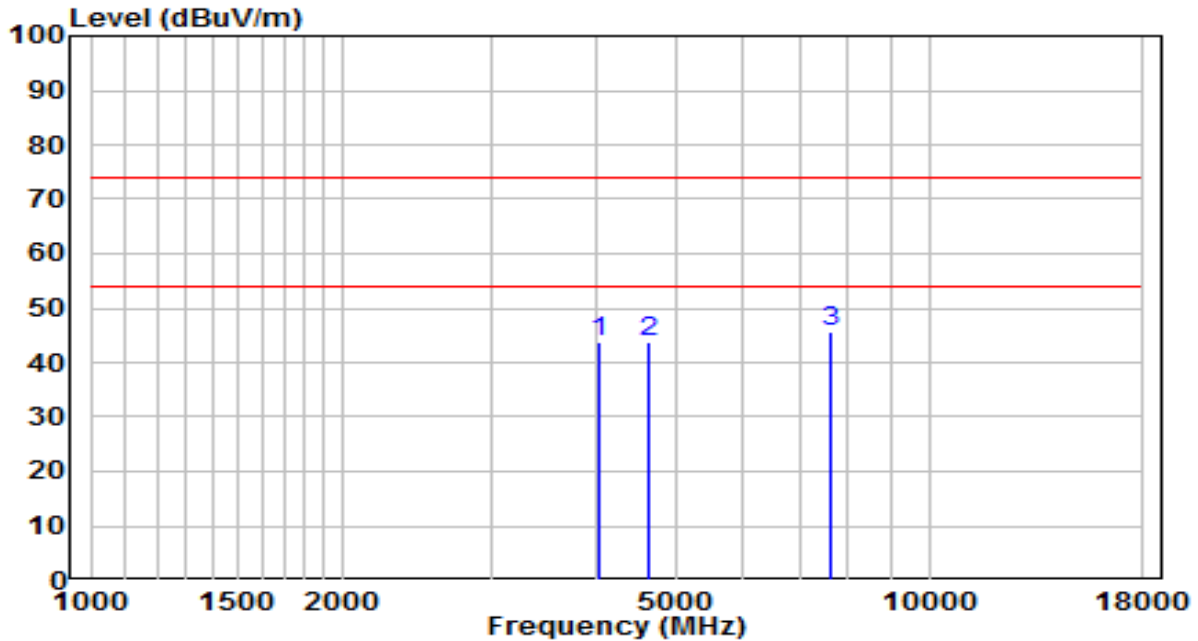

No	Frequency (MHz)	Reading (dBuV)	C.F (dB)	Measurement (dBuV/m)	Margin (dB)	Limit (dBuV/m)	Remark (QP/PK/AV)
1	4026.000	42.87	0.97	43.84	-30.16	74.00	Peak
2	4638.000	40.89	2.88	43.78	-30.22	74.00	Peak
3	* 7630.000	33.60	11.93	45.53	-28.47	74.00	Peak

Note:

1. " \*", means this data is the worst emission level.
2. C.F (Correction Factor) = Antenna Factor (dB) + Cable Loss (dB)– Pre-amplifier(dB).
3. Measurement(dBuV/m) = Reading(dBuV) + C.F (Correction Factor).
4. The emission levels of other frequencies are very lower than the limit and not show in test report.



EUT	ACCESS POINT	Date of Test	2021-03-10
Factor	BBHA 9120D	Temp. / Humidity	20.8°C/35%
Polarity	Vertical	Site / Test Engineer	AC1 / Jay Chu
Test Mode	Transmit by BLE at Channel 2442MHz – 2Mbps	Test Voltage	120V/60Hz

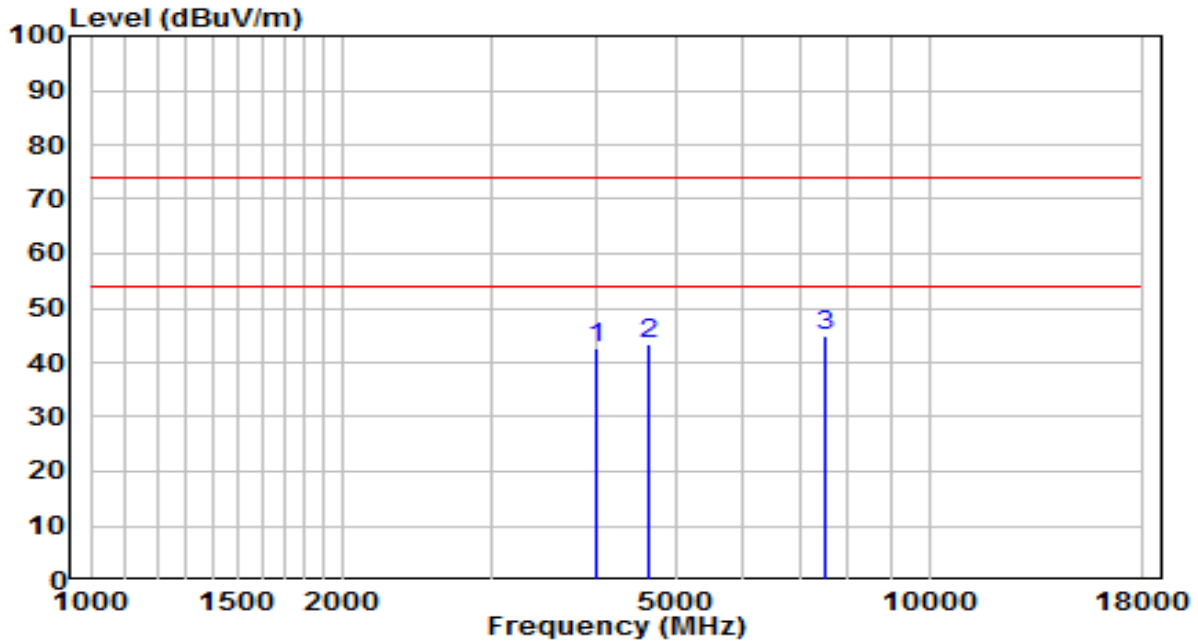

No	Frequency (MHz)	Reading (dBuV)	C.F (dB)	Measurement (dBuV/m)	Margin (dB)	Limit (dBuV/m)	Remark (QP/PK/AV)
1	4009.000	41.84	0.91	42.75	-31.25	74.00	Peak
2	4638.000	40.41	2.88	43.29	-30.71	74.00	Peak
3	* 7511.000	33.35	11.73	45.08	-28.92	74.00	Peak

Note:

1. " \*", means this data is the worst emission level.
2. C.F (Correction Factor) = Antenna Factor (dB) + Cable Loss (dB) – Pre-amplifier(dB).
3. Measurement(dBuV/m) = Reading(dBuV) + C.F (Correction Factor).
4. The emission levels of other frequencies are very lower than the limit and not show in test report.

EUT	ACCESS POINT	Date of Test	2021-03-10
Factor	BBHA 9120D	Temp. / Humidity	20.8°C/35%
Polarity	Horizontal	Site / Test Engineer	AC1 / Jay Chu
Test Mode	Transmit by BLE at Channel 2480MHz – 2Mbps	Test Voltage	120V/60Hz

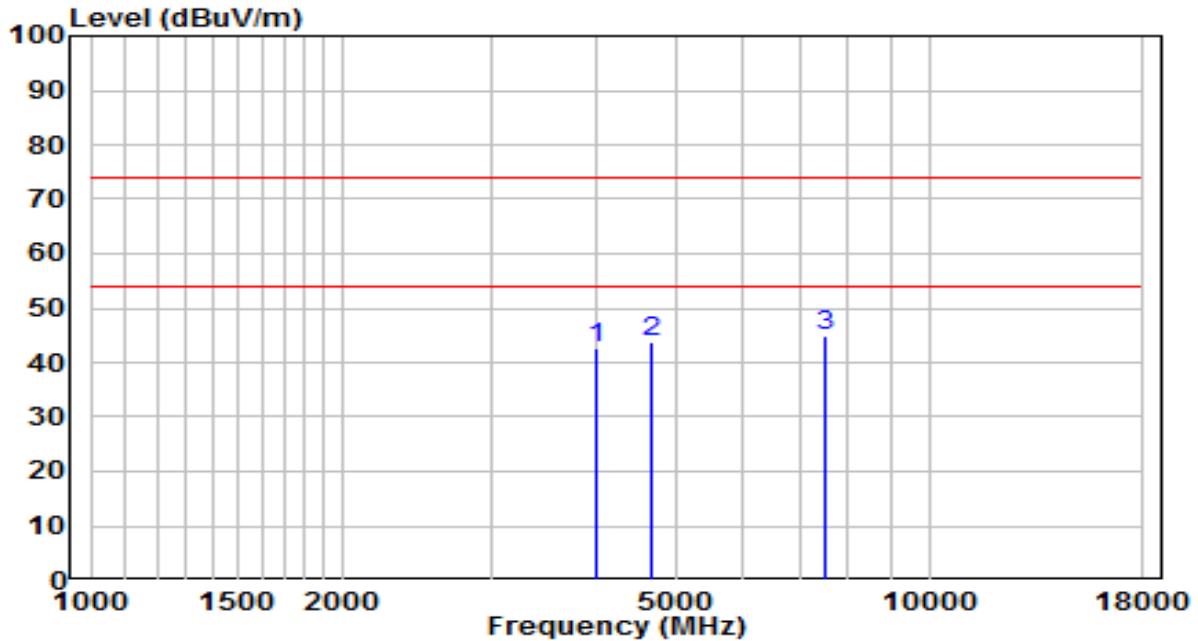

No	Frequency (MHz)	Reading (dBUV)	C.F (dB)	Measurement (dBUV/m)	Margin (dB)	Limit (dBUV/m)	Remark (QP/PK/AV)
1	4009.000	41.68	0.91	42.59	-31.41	74.00	Peak
2	4655.000	40.90	2.92	43.83	-30.17	74.00	Peak
3	* 7528.000	33.26	11.76	45.02	-28.98	74.00	Peak

Note:

1. " \*", means this data is the worst emission level.
2. C.F (Correction Factor) = Antenna Factor (dB) + Cable Loss (dB)– Preamplifier(dB).
3. Measurement(dBUV/m) = Reading(dBUV) + C.F (Correction Factor).
4. The emission levels of other frequencies are very lower than the limit and not show in test report.

EUT	ACCESS POINT	Date of Test	2021-03-10
Factor	BBHA 9120D	Temp. / Humidity	20.8°C/35%
Polarity	Vertical	Site / Test Engineer	AC1 / Jay Chu
Test Mode	Transmit by BLE at Channel 2480MHz – 2Mbps	Test Voltage	120V/60Hz

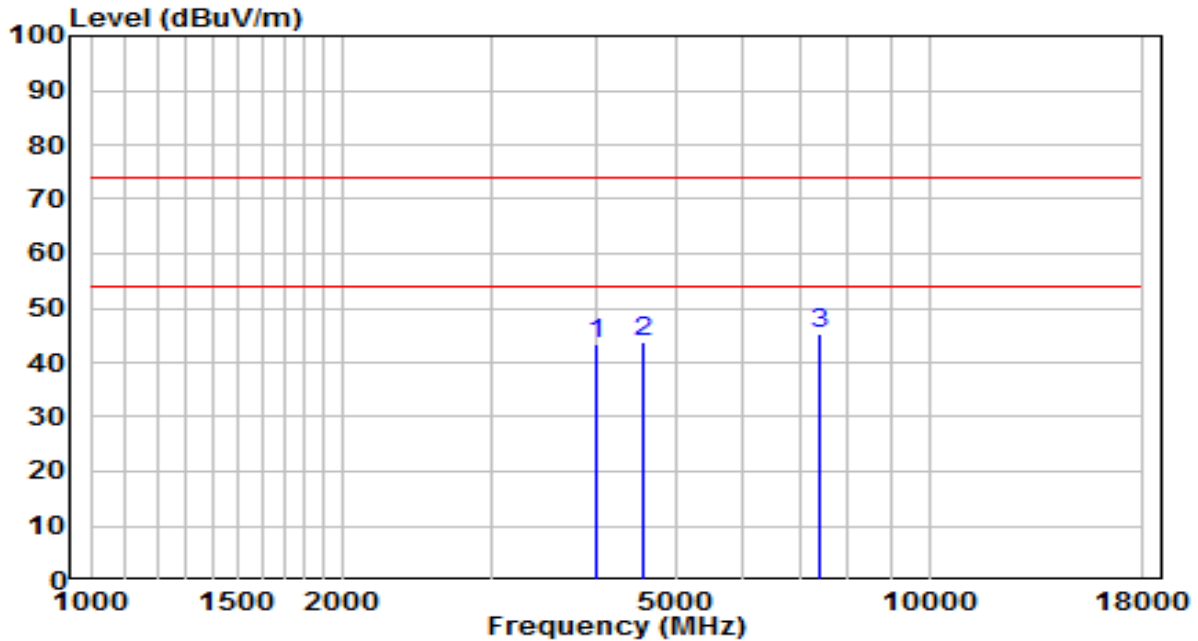

No	Frequency (MHz)	Reading (dBuV)	C.F (dB)	Measurement (dBuV/m)	Margin (dB)	Limit (dBuV/m)	Remark (QP/PK/AV)
1	4009.000	42.50	0.91	43.41	-30.59	74.00	Peak
2	4570.000	41.02	2.72	43.74	-30.26	74.00	Peak
3	* 7392.000	33.86	11.41	45.27	-28.73	74.00	Peak

Note:

1. " \*", means this data is the worst emission level.
2. C.F (Correction Factor) = Antenna Factor (dB) + Cable Loss (dB)– Pre-amplifier(dB).
3. Measurement(dBuV/m) = Reading(dBuV) + C.F (Correction Factor).
4. The emission levels of other frequencies are very lower than the limit and not show in test report.

**Filter Configuration 5#**

EUT	ACCESS POINT	Date of Test	2021-05-08
Factor	BBHA 9120D	Temp. / Humidity	24.2°C/38%
Polarity	Horizontal	Site / Test Engineer	AC1 / Jay Chu
Test Mode	Transmit by BLE at Channel 2402MHz – 2Mbps	Test Voltage	120V/60Hz

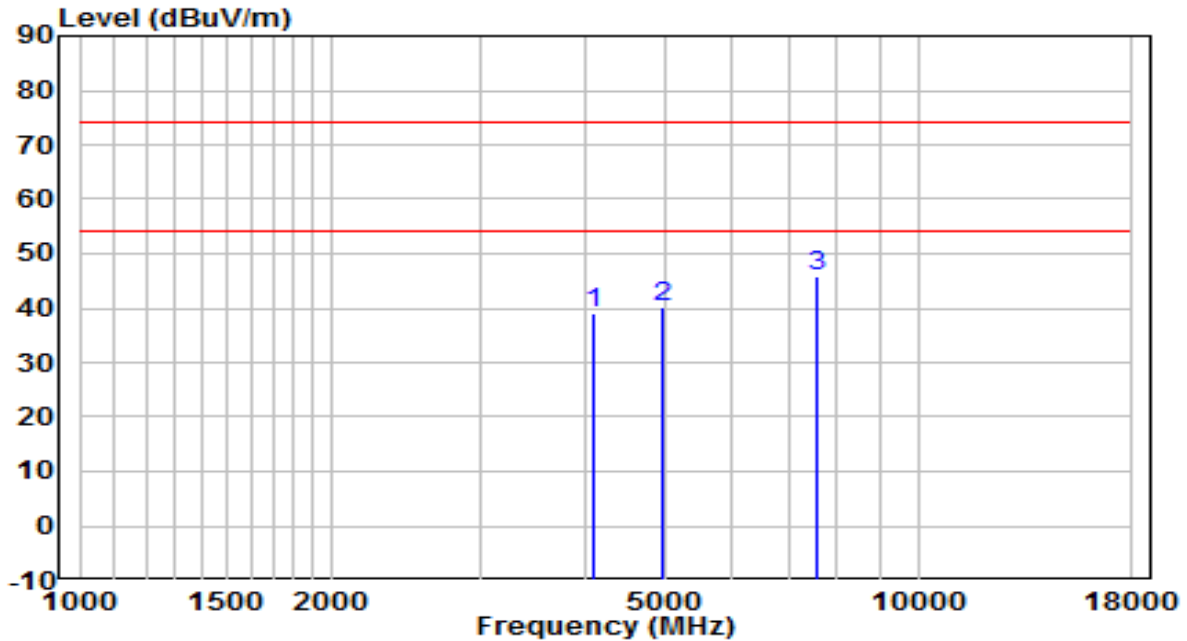

No	Frequency (MHz)	Reading (dBuV)	C.F (dB)	Measurement (dBuV/m)	Margin (dB)	Limit (dBuV/m)	Remark (QP/PK/AV)
1	4094.000	38.01	1.19	39.20	-34.80	74.00	Peak
2	4944.000	36.44	3.62	40.05	-33.95	74.00	Peak
3	* 7570.500	33.88	11.83	45.71	-28.29	74.00	Peak

**Note:**

- "\*", means this data is the worst emission level.
- C.F (Correction Factor) = Antenna Factor (dB)+ Cable Loss (dB)– Preamplifier(dB).
- Measurement(dBuV/m) = Reading(dBuV) + C.F (Correction Factor).
- The emission levels of other frequencies are very lower than the limit and not show in test report.
- For filter 5#, the worst case was performed in the report.

EUT	ACCESS POINT	Date of Test	2021-05-08
Factor	BBHA 9120D	Temp. / Humidity	24.2°C/38%
Polarity	Vertical	Site / Test Engineer	AC1 / Jay Chu
Test Mode	Transmit by BLE at Channel 2402MHz – 2Mbps	Test Voltage	120V/60Hz

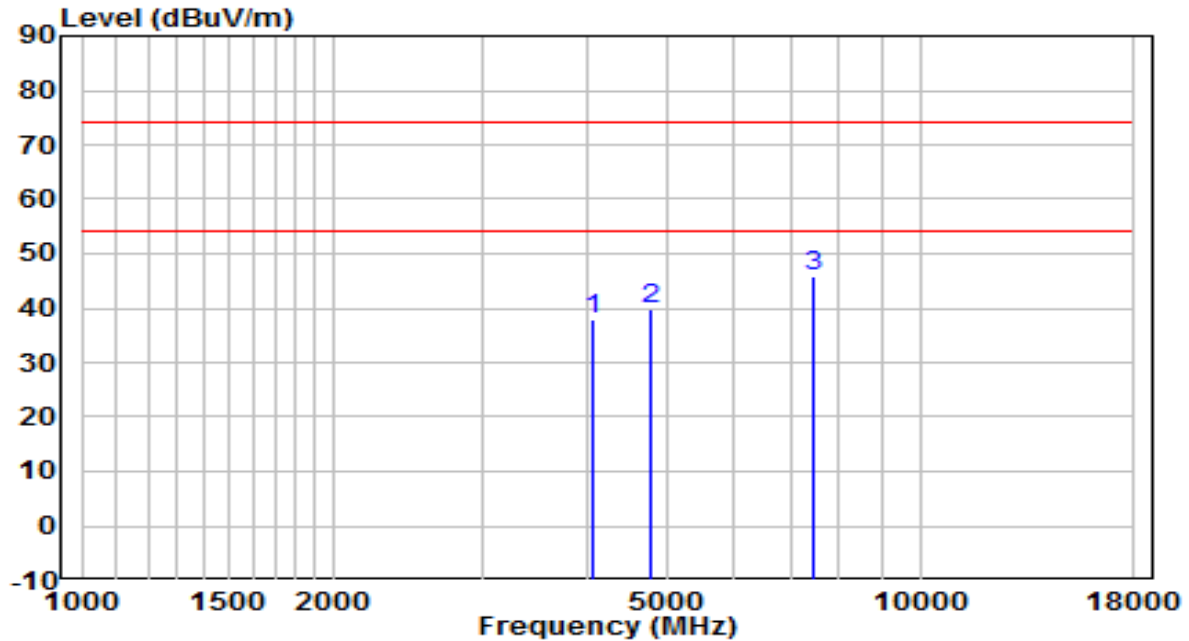

No	Frequency (MHz)	Reading (dBuV)	C.F (dB)	Measurement (dBuV/m)	Margin (dB)	Limit (dBuV/m)	Remark (QP/PK/AV)
1	4068.500	36.93	1.11	38.04	-35.96	74.00	Peak
2	4757.000	36.61	3.17	39.77	-34.23	74.00	Peak
3	* 7443.000	34.22	11.55	45.77	-28.23	74.00	Peak

Note:

1. " \*", means this data is the worst emission level.
2. C.F (Correction Factor) = Antenna Factor (dB)+ Cable Loss (dB)– Preamplifier(dB).
3. Measurement(dBuV/m) = Reading(dBuV) + C.F (Correction Factor).
- 4.The emission levels of other frequencies are very lower than the limit and not show in test report.
5. For filter 5#, the worst case was performed in the report.

**Filter Configuration 6#**

EUT	ACCESS POINT	Date of Test	2021-05-08
Factor	BBHA 9120D	Temp. / Humidity	24.2°C/38%
Polarity	Horizontal	Site / Test Engineer	AC1 / Jay Chu
Test Mode	Transmit by BLE at Channel 2480MHz – 2Mbps	Test Voltage	120V/60Hz

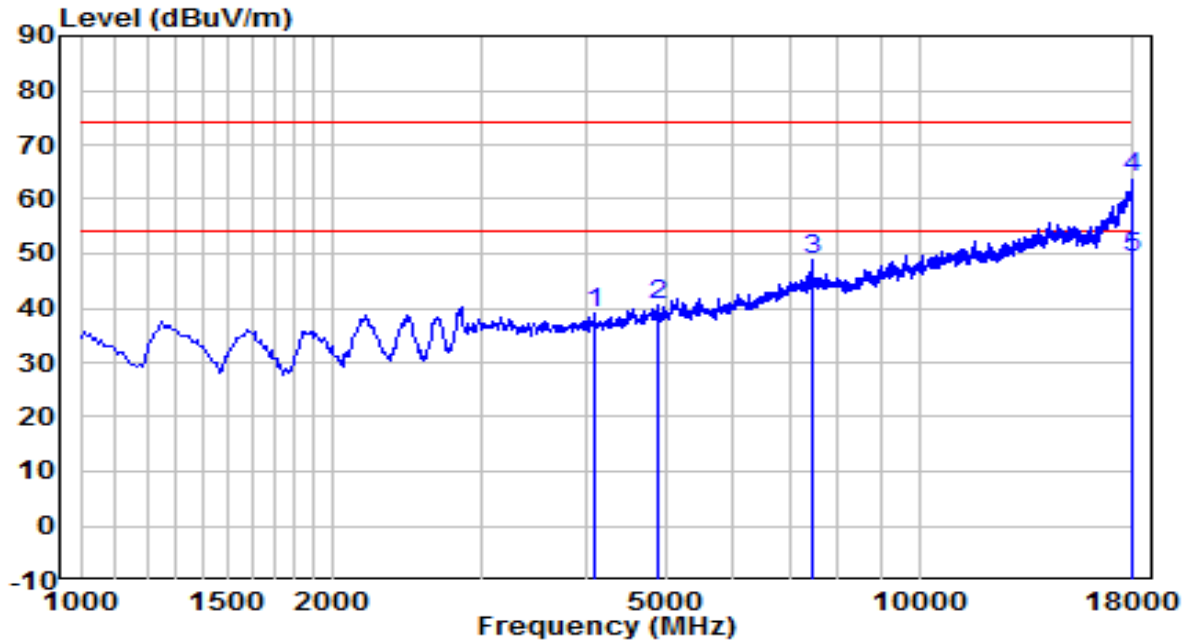

No	Frequency (MHz)	Reading (dBUV)	C.F (dB)	Measurement (dBUV/m)	Margin (dB)	Limit (dBUV/m)	Remark (QP/PK/AV)
1	4094.000	37.76	1.19	38.95	-35.05	74.00	Peak
2	4867.500	37.10	3.43	40.53	-33.47	74.00	Peak
3	7434.500	37.21	11.53	48.74	-25.26	74.00	Peak
4	18000.000	31.96	32.07	64.03	-9.97	74.00	Peak
5	* 18000.000	17.05	32.07	49.12	-4.88	54.00	Average

Note:

1. " \*", means this data is the worst emission level.
2. C.F (Correction Factor) = Antenna Factor (dB)+ Cable Loss (dB)– Preamplifier(dB).
3. Measurement(dBUV/m) = Reading(dBUV) + C.F (Correction Factor).
- 4.The emission levels of other frequencies are very lower than the limit and not show in test report.
5. For filter 6#, the worst case was performed in the report.
6. We only show the worst case test trace for this mode.

EUT	ACCESS POINT	Date of Test	2021-05-08
Factor	BBHA 9120D	Temp. / Humidity	24.2°C/38%
Polarity	Vertical	Site / Test Engineer	AC1 / Jay Chu
Test Mode	Transmit by BLE at Channel 2480MHz – 2Mbps	Test Voltage	120V/60Hz

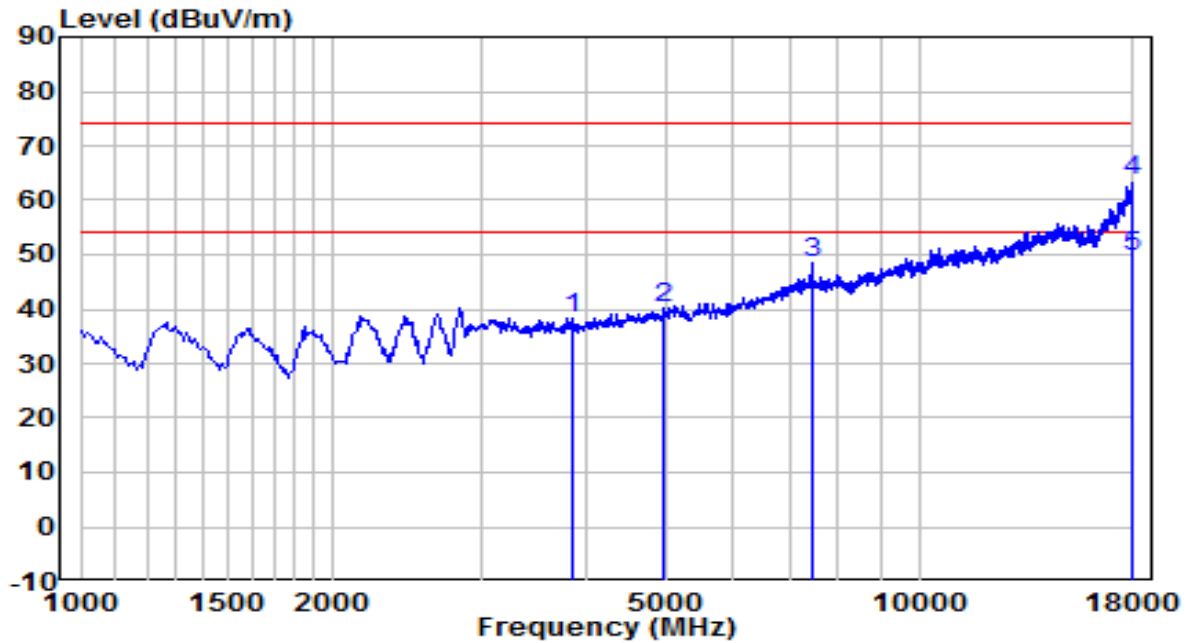

No	Frequency (MHz)	Reading (dBuV)	C.F (dB)	Measurement (dBuV/m)	Margin (dB)	Limit (dBuV/m)	Remark (QP/PK/AV)
1	3856.000	38.03	0.38	38.42	-35.58	74.00	Peak
2	4952.500	36.42	3.64	40.05	-33.95	74.00	Peak
3	7434.500	37.10	11.53	48.63	-25.37	74.00	Peak
4	17991.500	31.63	32.05	63.68	-10.32	74.00	Peak
5	* 17991.500	17.55	32.05	49.60	-4.40	54.00	Average

Note:

1. " \*", means this data is the worst emission level.
2. C.F (Correction Factor) = Antenna Factor (dB)+ Cable Loss (dB)– Preamplifier(dB).
3. Measurement(dBuV/m) = Reading(dBuV) + C.F (Correction Factor).
- 4.The emission levels of other frequencies are very lower than the limit and not show in test report.
5. For filter 6#, the worst case was performed in the report.
6. We only show the worst case test trace for this mode.

**The Result of Radiated Spurious Emission below 1GHz:**

EUT	ACCESS POINT	Date of Test	2021-04-28
Factor	VULB 9162	Temp. / Humidity	23.0°C/50.5%
Polarity	Horizontal	Site / Test Engineer	AC1 / Jay Chu
Test Mode	Transmit by BLE at channel 2442MHz – 1Mbps	Test Voltage	120V/60Hz

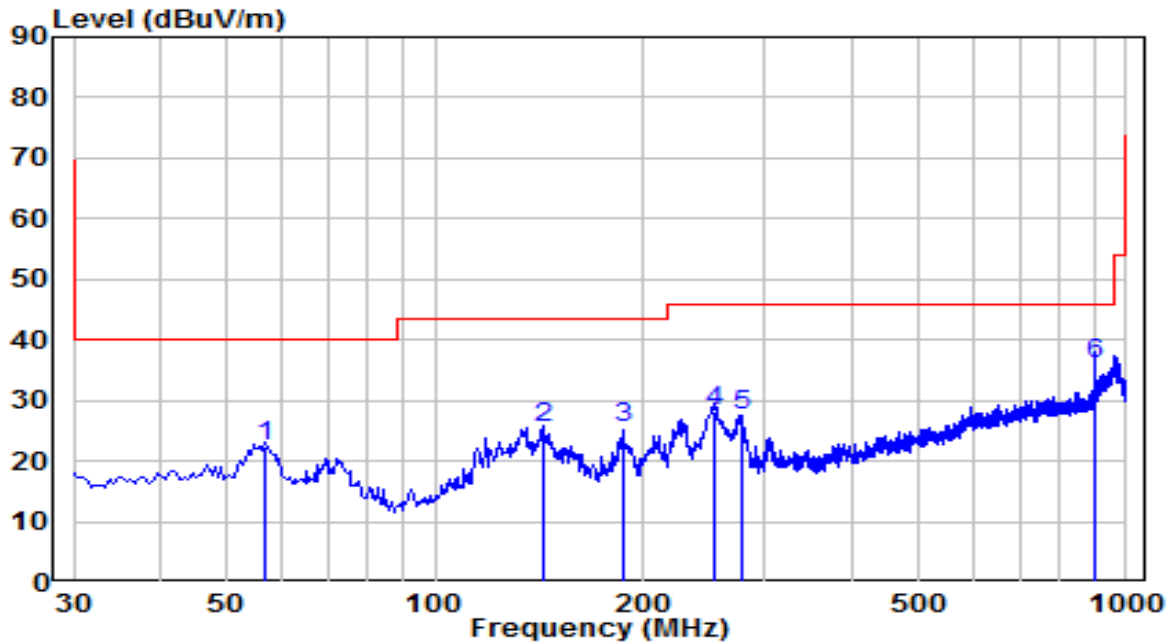

No	Frequency (MHz)	Reading (dBuV)	C.F (dB)	Measurement (dBuV/m)	Margin (dB)	Limit (dBuV/m)	Remark (QP/PK/AV)
1	56.675	1.57	20.82	22.39	-17.61	40.00	QP
2	143.490	9.54	16.01	25.55	-17.95	43.50	QP
3	186.655	6.91	18.40	25.31	-18.19	43.50	QP
4	252.615	7.68	20.55	28.23	-17.77	46.00	QP
5	276.865	6.74	20.93	27.67	-18.33	46.00	QP
6	* 900.090	4.16	31.77	35.93	-10.07	46.00	QP

Note:

1. " \*", means this data is the worst emission level.
2. C.F (Correction Factor) = Antenna Factor (dB) + Cable Loss (dB).
3. Measurement(dBuV/m) = Reading(dBuV) + C.F (Correction Factor).
4. The emission levels of other frequencies are very lower than the limit and not show in test report.
5. The amplitude of Radiated emissions (the test frequency range: 9kHz ~ 30MHz, 18GHz ~ 25GHz), is that proximity to ambient noise, which also are attenuated more than 20 dB below the permissible value. Therefore, the data is not presented in the report.



EUT	ACCESS POINT	Date of Test	2021-04-28
Factor	VULB 9162	Temp. / Humidity	23.0°C/50.5%
Polarity	Vertical	Site / Test Engineer	AC1 / Jay Chu
Test Mode	Transmit by BLE at channel 2442MHz – 1Mbps	Test Voltage	120V/60Hz

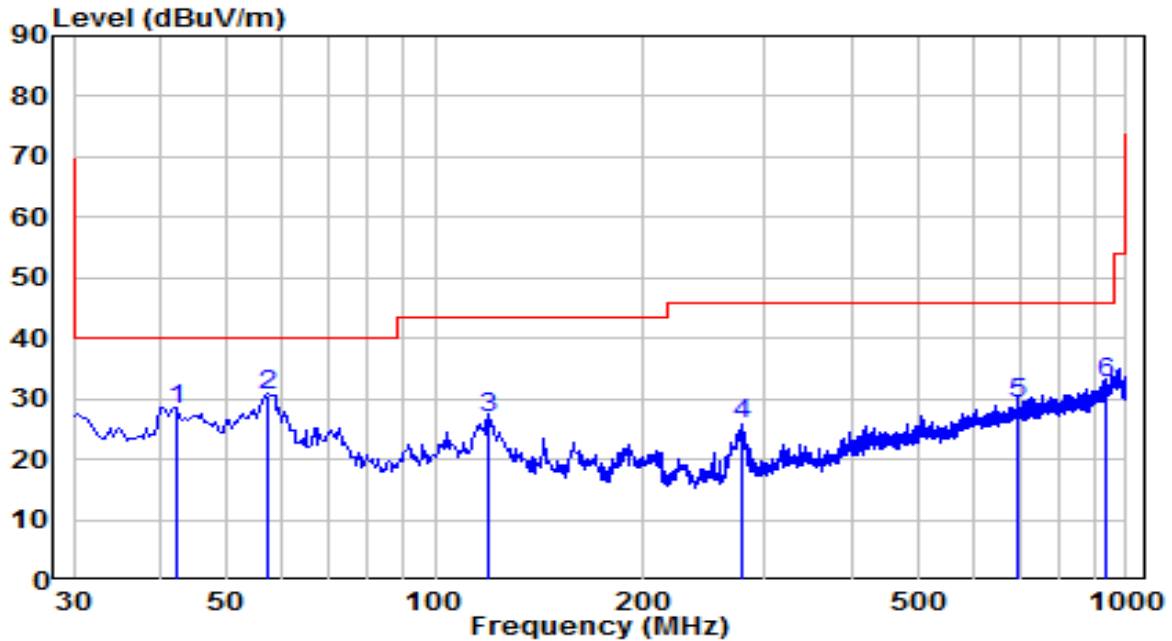

No	Frequency (MHz)	Reading (dBUV)	C.F (dB)	Measurement (dBUV/m)	Margin (dB)	Limit (dBUV/m)	Remark (QP/PK/AV)
1	42.125	6.72	21.38	28.10	-11.90	40.00	QP
2	57.160	9.74	20.73	30.47	-9.53	40.00	QP
3	119.240	9.37	17.35	26.72	-16.78	43.50	QP
4	276.865	4.76	20.93	25.69	-20.31	46.00	QP
5	697.360	-0.11	29.28	29.17	-16.83	46.00	QP
6	932.100	0.57	32.02	32.59	-13.41	46.00	QP

Note:

1. " \*\*", means this data is the worst emission level.
2. C.F (Correction Factor) = Antenna Factor (dB) + Cable Loss (dB).
3. Measurement(dBUV/m) = Reading(dBUV) + C.F (Correction Factor).
4. The emission levels of other frequencies are very lower than the limit and not show in test report.
5. The amplitude of Radiated emissions (the test frequency range: 9kHz ~ 30MHz, 18GHz ~ 25GHz), is that proximity to ambient noise, which also are attenuated more than 20 dB below the permissible value. Therefore, the data is not presented in the report.

**The Worst Result of Radiated Spurious Emission above 18GHz:**

EUT	ACCESS POINT	Date of Test	2021-05-08
Factor	BBHA 9170	Temp. / Humidity	20.8°C / 42%
Polarity	Horizontal	Site / Test Engineer	AC1 / Jay Chu
Test Mode	Transmit by BLE at channel 2442MHz – 1Mbps	Test Voltage	120V/60Hz

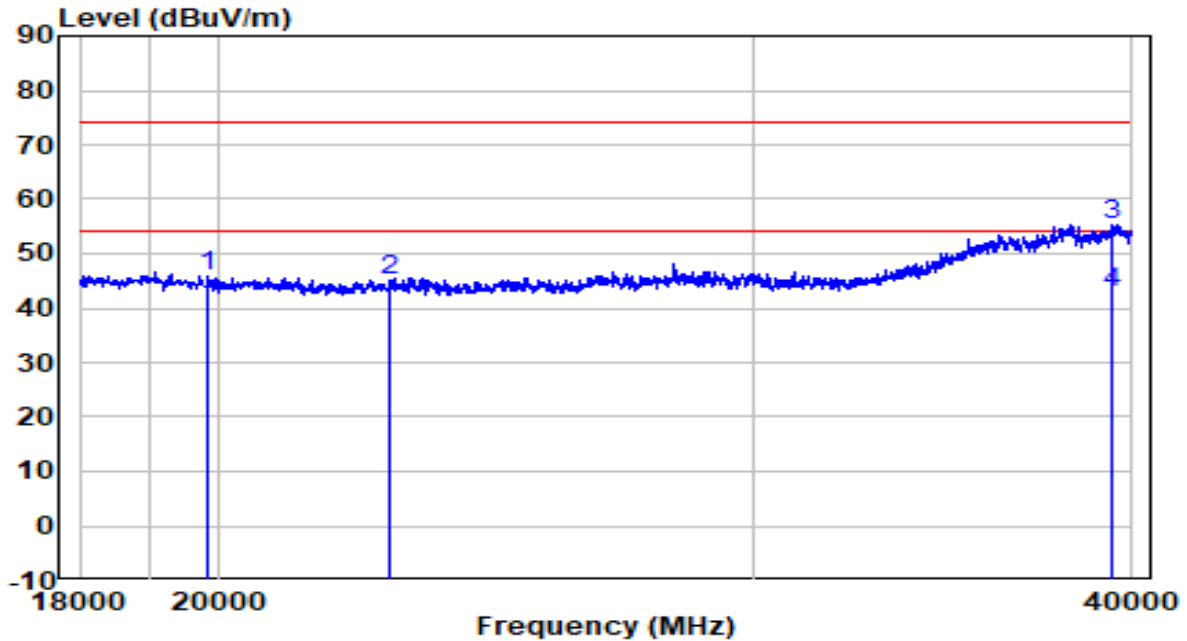

No	Frequency (MHz)	Reading (dBuV)	C.F (dB)	Measurement (dBuV/m)	Margin (dB)	Limit (dBuV/m)	Remark (QP/PK/AV)
1	19826.000	579.14	-533.20	45.94	-28.06	74.00	Peak
2	22774.000	579.41	-534.25	45.16	-28.84	74.00	Peak
3	39395.000	586.94	-531.48	55.46	-18.54	74.00	Peak
4	* 39395.000	574.40	-531.48	42.93	-11.07	54.00	Average

Note:

- "\*" means this data is the worst emission level.
- C.F (Correction Factor) = Antenna Factor (dB)+ Cable Loss (dB)– Preamplifier(dB).
- Measurement(dBuV/m) = Reading(dBuV) + C.F (Correction Factor).
- The emission levels of other frequencies are very lower than the limit and not show in test report.

EUT	ACCESS POINT	Date of Test	2021-05-08
Factor	BBHA 9170	Temp. / Humidity	20.8°C / 42%
Polarity	Vertical	Site / Test Engineer	AC1 / Jay Chu
Test Mode	Transmit by BLE at channel 2442MHz – 1Mbps	Test Voltage	120V/60Hz

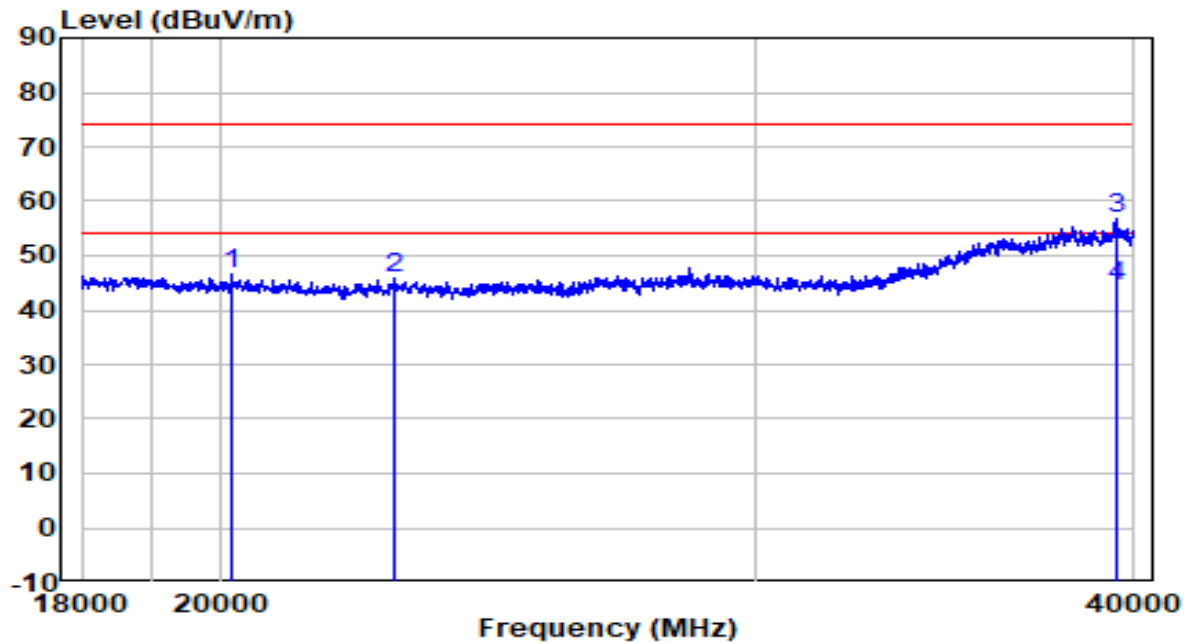

No	Frequency (MHz)	Reading (dBuV)	C.F (dB)	Measurement (dBuV/m)	Margin (dB)	Limit (dBuV/m)	Remark (QP/PK/AV)
1	20178.000	579.83	-533.24	46.59	-27.41	74.00	Peak
2	22796.000	580.12	-534.24	45.88	-28.12	74.00	Peak
3	39439.000	588.45	-531.49	56.96	-17.04	74.00	Peak
4	* 39439.000	575.87	-531.49	44.38	-9.62	54.00	Average

Note:

- "\*" means this data is the worst emission level.
- C.F (Correction Factor) = Antenna Factor (dB)+ Cable Loss (dB)– Preamplifier(dB).
- Measurement(dBuV/m) = Reading(dBuV) + C.F (Correction Factor).
- The emission levels of other frequencies are very lower than the limit and not show in test report.

## 7.7. Radiated Restricted Band Edge Measurement

### 7.7.1. Test Limit

#### For 15.205 requirement:

Radiated emissions which fall in the restricted bands, as defined in Section 15.205(a) of FCC part 15, must also comply with the radiated emission limits specified in Section 15.209(a).

Frequency (MHz)	Frequency (MHz)	Frequency (MHz)	Frequency (GHz)
0.090 - 0.110	16.42 - 16.423	399.9 - 410	4.5 - 5.15
<sup>1</sup> 0.495 - 0.505	16.69475 - 16.69525	608 - 614	5.35 - 5.46
2.1735 - 2.1905	16.80425 - 16.80475	960 - 1240	7.25 - 7.75
4.125 - 4.128	25.5 - 25.67	1300 - 1427	8.025 - 8.5
4.17725 - 4.17775	37.5 - 38.25	1435 - 1626.5	9.0 - 9.2
4.20725 - 4.20775	73 - 74.6	1645.5 - 1646.5	9.3 - 9.5
6.215 - 6.218	74.8 - 75.2	1660 - 1710	10.6 - 12.7
6.26775 - 6.26825	108 - 121.94	1718.8 - 1722.2	13.25 - 13.4
6.31175 - 6.31225	123 - 138	2200 - 2300	14.47 - 14.5
8.291 - 8.294	149.9 - 150.05	2310 - 2390	15.35 - 16.2
8.362 - 8.366	156.52475 - 156.525	2483.5 - 2500	17.7 - 21.4
8.37625 - 8.38675	156.7 - 156.9	2690 - 2900	22.01 - 23.12
8.41425 - 8.41475	162.0125 - 167.17	3260 - 3267	23.6 - 24.0
12.29 - 12.293	167.72 - 173.2	3332 - 3339	31.2 - 31.8
12.51975 - 12.52025	240 - 285	3345.8 - 3358	36.43 - 36.5
12.57675 - 12.57725	322 - 335.4	3600 - 4400	( <sup>2</sup> )
13.36 - 13.41	--	--	--

All out of band emissions appearing in a restricted band as specified in Section 15.205 of the Title 47CFR must not exceed the limits shown in Table per Section 15.209.

FCC Part 15 Subpart C Paragraph 15.209		
Frequency [MHz]	Field Strength [uV/m]	Measured Distance [Meters]
0.009 - 0.490	2400/F (kHz)	300
0.490 - 1.705	24000/F (kHz)	30
1.705 - 30	30	30
30 - 88	100	3
88 - 216	150	3
216 - 960	200	3
Above 960	500	3

### 7.7.2. Test Procedure Used

ANSI C63.10-2013 Section 6.3 (General Requirements)

ANSI C63.10-2013 Section 6.6 (Standard test method above 1GHz)

ANSI C63.10-2013 Section 11.13

### 7.7.3. Test Setting

#### Peak Field Strength Measurements

1. Analyzer center frequency was set to the frequency of the radiated spurious emission of interest
2. RBW = 1MHz
3. VBW = 3MHz
4. Detector = peak
5. Sweep time = auto couple
6. Trace mode = max hold
7. Trace was allowed to stabilize

### Average Field Strength Measurements

1. Analyzer center frequency was set to the frequency of the radiated spurious emission of interest
2. RBW = 1MHz
3. VBW  $\geq 1/T$ , (For 1Mbps, VBW = 10kHz; For 2Mbps, VBW = 20kHz)
4. Average Type = Voltage
5. Detector = Peak
6. Sweep time = auto
7. Trace mode = max hold
8. Trace was allowed to stabilize

#### 7.7.4. Test Setup

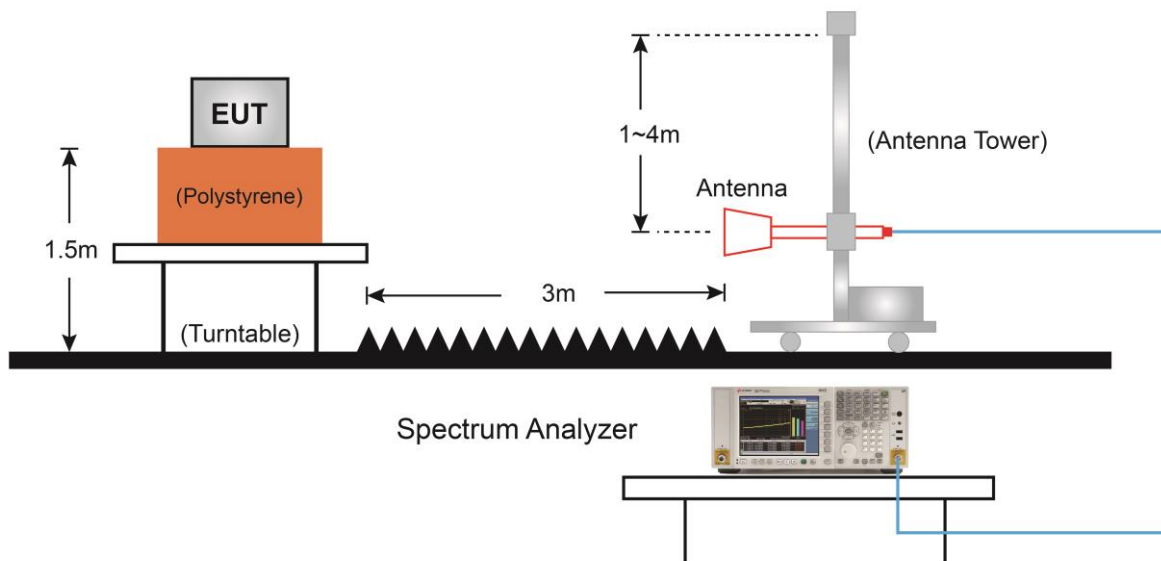

### 7.7.5. Test Result

#### Filter Configuration 4#

EUT	ACCESS POINT	Date of Test	2021-03-10
Factor	BBHA 9120D	Temp. / Humidity	21.8°C/35%
Polarity	Horizontal	Site / Test Engineer	AC1 / Jay Chu
Test Mode	Transmit by BLE at Channel 2402MHz -1Mbps	Test Voltage	120V/60Hz

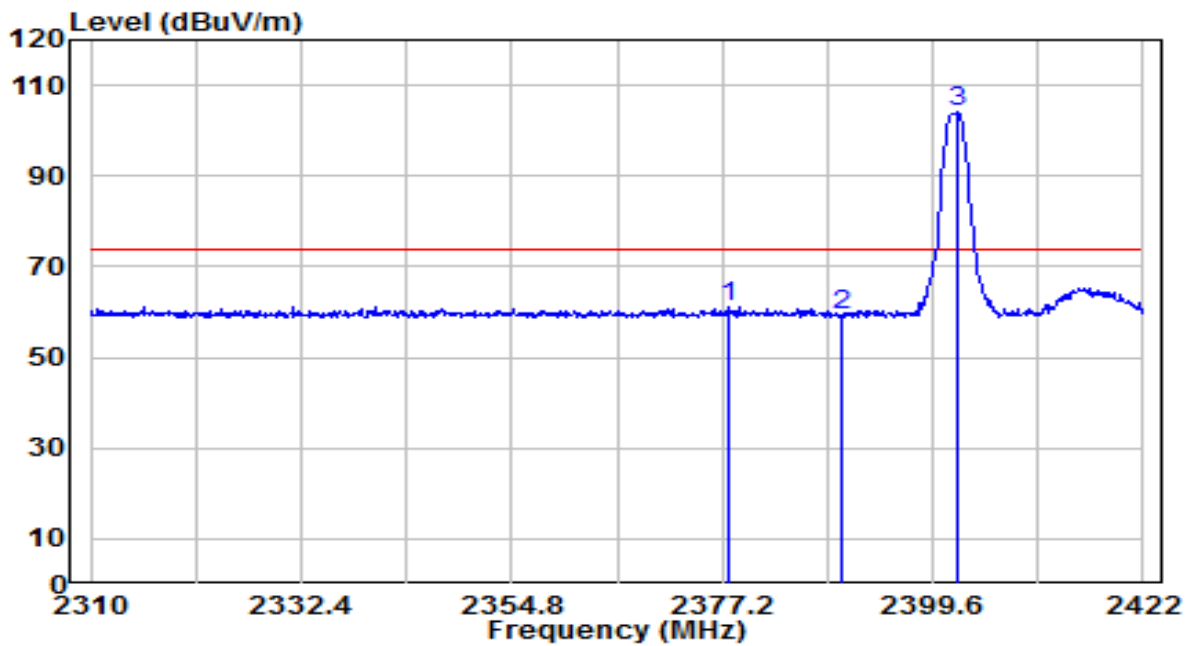

No	Frequency (MHz)	Reading (dBuV)	C.F (dB)	Measurement (dBuV/m)	Margin (dB)	Limit (dBuV/m)	Remark (QP/PK/AV)
1	* 2377.760	28.77	32.24	61.01	-12.99	74.00	Peak
2	2390.000	27.06	32.30	59.36	-14.64	74.00	Peak
3	2402.176	71.59	32.35	103.94	N/A	N/A	Peak

Note:

1. " \*", means this data is the worst emission level.
2. C.F (Correction Factor) = Antenna Factor (dB) + Cable Loss (dB).
3. Measurement(dBuV/m) = Reading(dBuV) + C.F (Correction Factor).
4. The emission levels of other frequencies are very lower than the limit and not show in test report.

EUT	ACCESS POINT	Date of Test	2021-03-10
Factor	BBHA 9120D	Temp. / Humidity	21.8°C/35%
Polarity	Horizontal	Site / Test Engineer	AC1 / Jay Chu
Test Mode	Transmit by BLE at Channel 2402MHz -1Mbps	Test Voltage	120V/60Hz

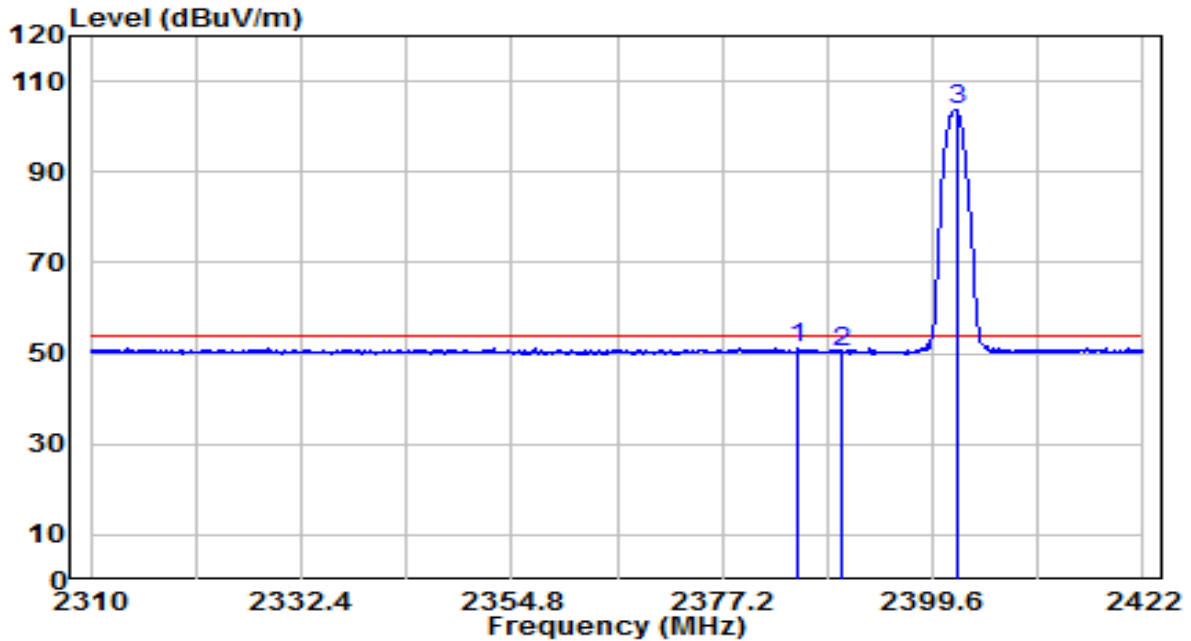

No	Frequency (MHz)	Reading (dBuV)	C.F (dB)	Measurement (dBuV/m)	Margin (dB)	Limit (dBuV/m)	Remark (QP/PK/AV)
1	*	18.94	32.28	51.22	-2.78	54.00	AV
2		18.12	32.30	50.41	-3.59	54.00	AV
3		71.57	32.35	103.92	N/A	N/A	AV

Note:

1. " \*", means this data is the worst emission level.
2. C.F (Correction Factor) = Antenna Factor (dB) + Cable Loss (dB).
3. Measurement(dBuV/m) = Reading(dBuV) + C.F (Correction Factor).
4. The emission levels of other frequencies are very lower than the limit and not show in test report.



EUT	ACCESS POINT	Date of Test	2021-03-10
Factor	BBHA 9120D	Temp. / Humidity	21.8°C/35%
Polarity	Vertical	Site / Test Engineer	AC1 / Jay Chu
Test Mode	Transmit by BLE at Channel 2402MHz -1Mbps	Test Voltage	120V/60Hz

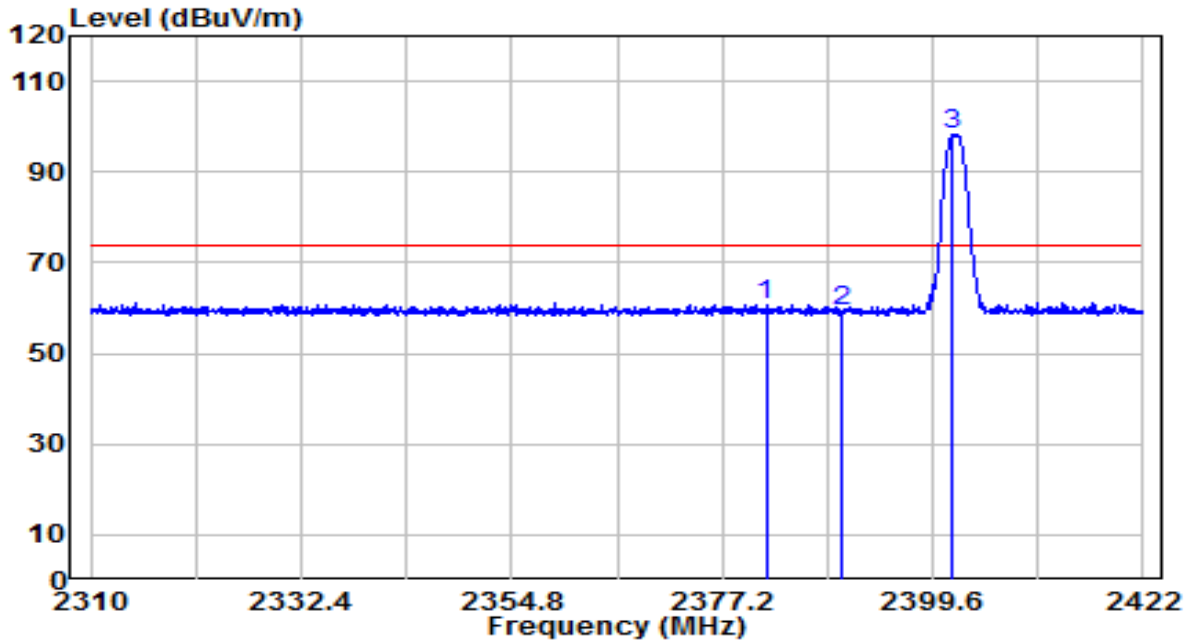

No	Frequency (MHz)	Reading (dBuV)	C.F (dB)	Measurement (dBuV/m)	Margin (dB)	Limit (dBuV/m)	Remark (QP/PK/AV)
1	*	28.48	32.26	60.74	-13.26	74.00	Peak
2		26.95	32.30	59.25	-14.75	74.00	Peak
3		65.90	32.35	98.25	N/A	N/A	Peak

Note:

1. " \*", means this data is the worst emission level.
2. C.F (Correction Factor) = Antenna Factor (dB) + Cable Loss (dB).
3. Measurement(dBuV/m) = Reading(dBuV) + C.F (Correction Factor).
4. The emission levels of other frequencies are very lower than the limit and not show in test report.

EUT	ACCESS POINT	Date of Test	2021-03-10
Factor	BBHA 9120D	Temp. / Humidity	21.8°C/35%
Polarity	Vertical	Site / Test Engineer	AC1 / Jay Chu
Test Mode	Transmit by BLE at Channel 2402MHz -1Mbps	Test Voltage	120V/60Hz

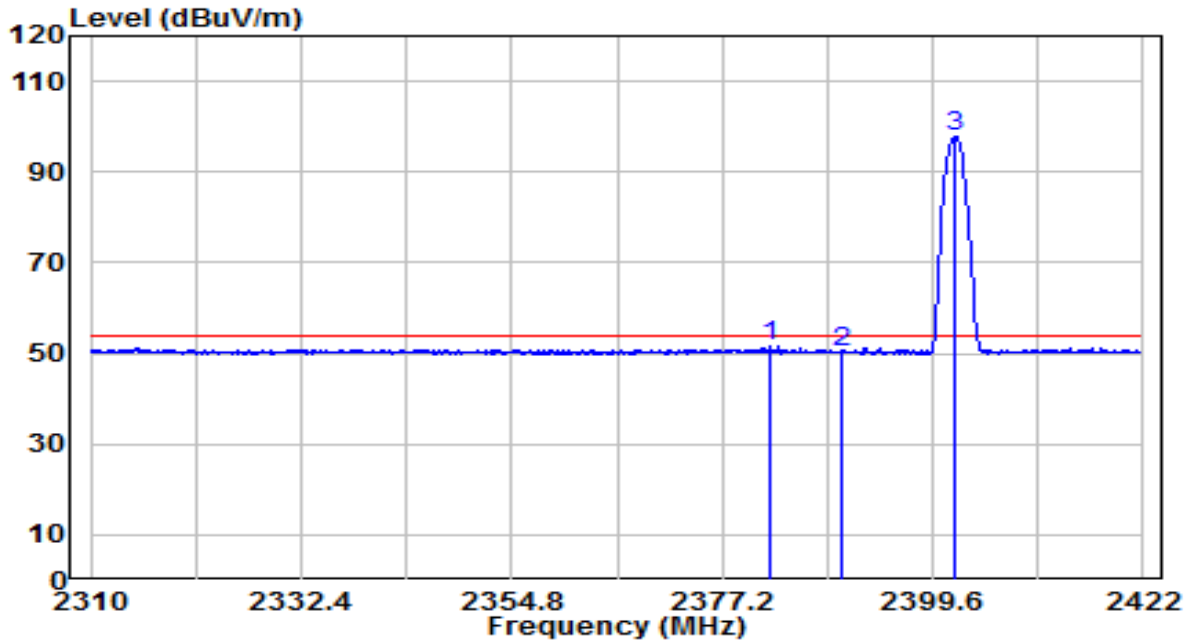

No	Frequency (MHz)	Reading (dBuV)	C.F (dB)	Measurement (dBuV/m)	Margin (dB)	Limit (dBuV/m)	Remark (QP/PK/AV)	
1	*	2382.408	19.15	32.26	51.42	-2.58	54.00	AV
2		2390.000	17.97	32.30	50.26	-3.74	54.00	AV
3		2402.008	65.64	32.35	97.99	N/A	N/A	AV

Note:

1. " \*", means this data is the worst emission level.
2. C.F (Correction Factor) = Antenna Factor (dB) + Cable Loss (dB).
3. Measurement(dBuV/m) = Reading(dBuV) + C.F (Correction Factor).
4. The emission levels of other frequencies are very lower than the limit and not show in test report.

EUT	ACCESS POINT	Date of Test	2021-03-10
Factor	BBHA 9120D	Temp. / Humidity	21.8°C/35%
Polarity	Horizontal	Site / Test Engineer	AC1 / Jay Chu
Test Mode	Transmit by BLE at Channel 2480MHz -1Mbps	Test Voltage	120V/60Hz

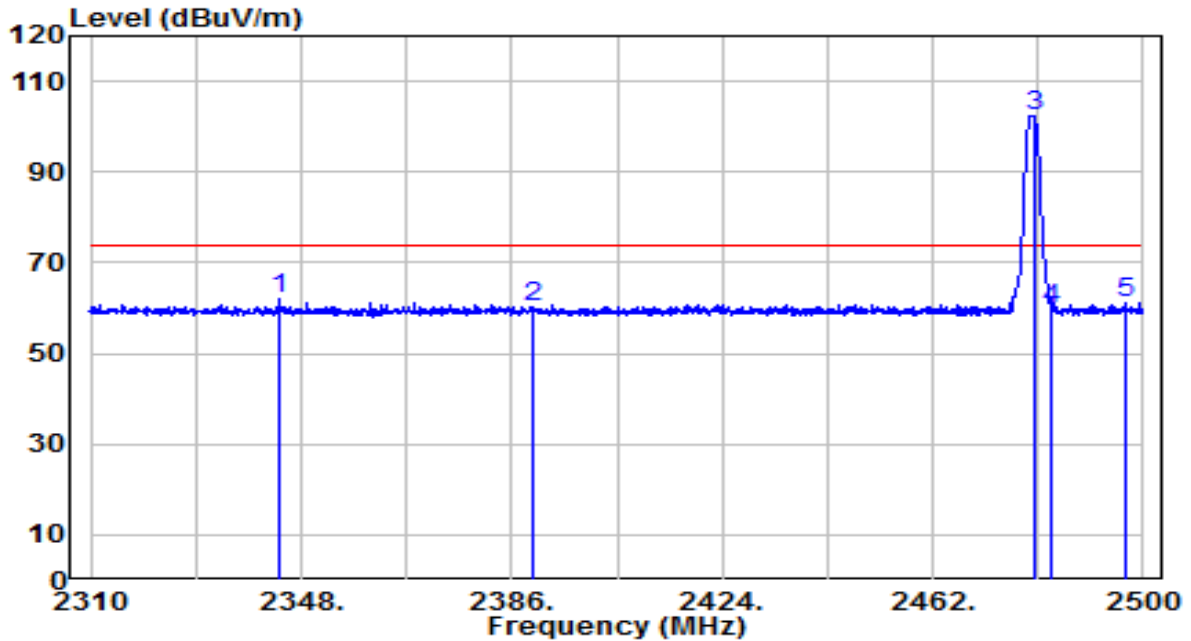

No	Frequency (MHz)	Reading (dBUV)	C.F (dB)	Measurement (dBUV/m)	Margin (dB)	Limit (dBUV/m)	Remark (QP/PK/AV)
1	* 2343.900	29.82	32.09	61.91	-12.09	74.00	Peak
2	2390.000	27.90	32.30	60.20	-13.80	74.00	Peak
3	2480.300	69.86	32.69	102.55	N/A	N/A	Peak
4	2483.500	27.17	32.71	59.88	-14.12	74.00	Peak
5	2496.900	28.24	32.77	61.01	-12.99	74.00	Peak

Note:

1. " \*", means this data is the worst emission level.
2. C.F (Correction Factor) = Antenna Factor (dB) + Cable Loss (dB).
3. Measurement(dBUV/m) = Reading(dBUV) + C.F (Correction Factor).
4. The emission levels of other frequencies are very lower than the limit and not show in test report.

EUT	ACCESS POINT	Date of Test	2021-03-10
Factor	BBHA 9120D	Temp. / Humidity	21.8°C/35%
Polarity	Horizontal	Site / Test Engineer	AC1 / Jay Chu
Test Mode	Transmit by BLE at Channel 2480MHz -1Mbps	Test Voltage	120V/60Hz

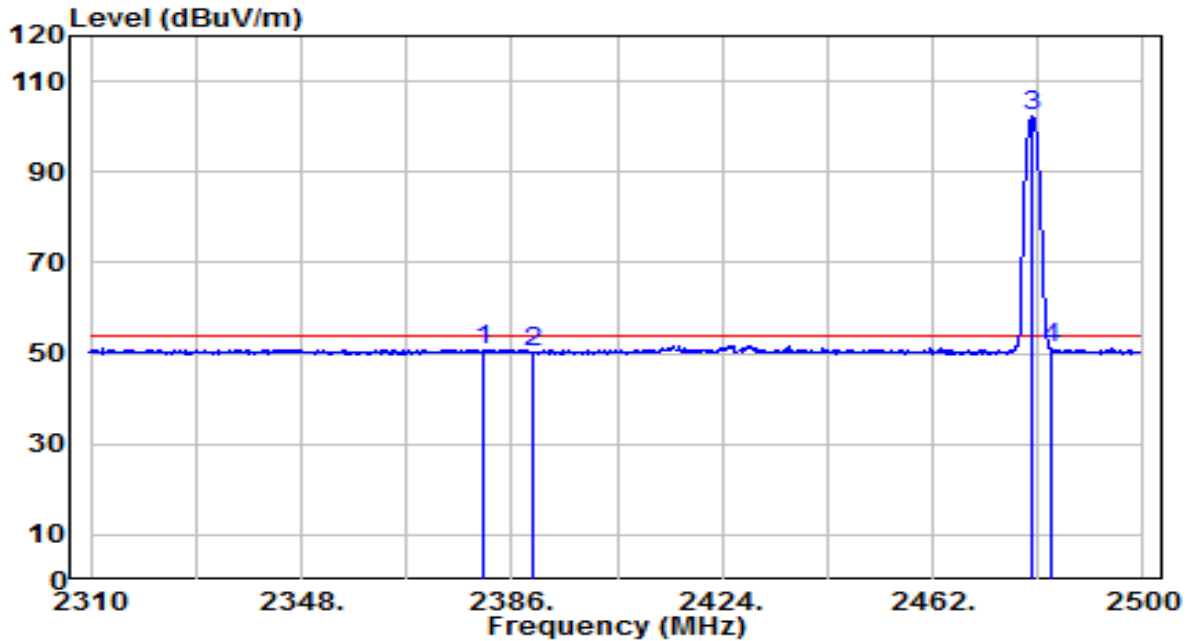

No	Frequency (MHz)	Reading (dBuV)	C.F (dB)	Measurement (dBuV/m)	Margin (dB)	Limit (dBuV/m)	Remark (QP/PK/AV)
1	2380.800	18.62	32.26	50.88	-3.12	54.00	AV
2	2390.000	17.77	32.30	50.06	-3.94	54.00	AV
3	2480.100	69.67	32.69	102.37	N/A	N/A	AV
4	* 2483.500	18.39	32.71	51.10	-2.90	54.00	AV

Note:

1. " \*", means this data is the worst emission level.
2. C.F (Correction Factor) = Antenna Factor (dB) + Cable Loss (dB).
3. Measurement(dBuV/m) = Reading(dBuV) + C.F (Correction Factor).
4. The emission levels of other frequencies are very lower than the limit and not show in test report.

EUT	ACCESS POINT	Date of Test	2021-03-10
Factor	BBHA 9120D	Temp. / Humidity	21.8°C/35%
Polarity	Vertical	Site / Test Engineer	AC1 / Jay Chu
Test Mode	Transmit by BLE at Channel 2480MHz -1Mbps	Test Voltage	120V/60Hz

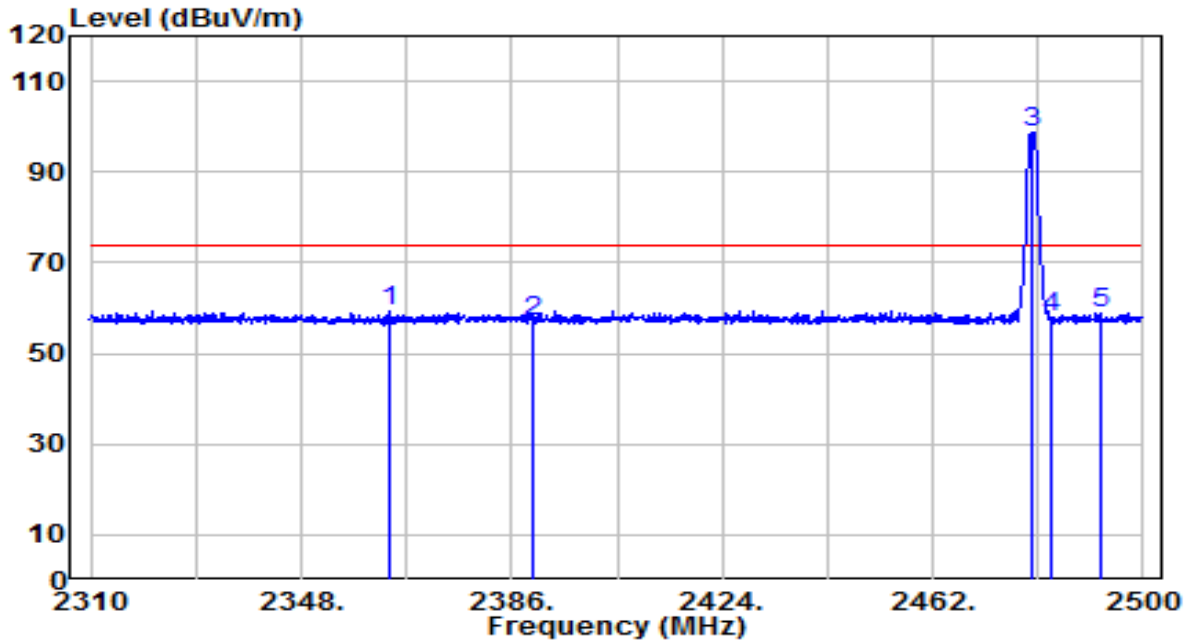

No	Frequency (MHz)	Reading (dBuV)	C.F (dB)	Measurement (dBuV/m)	Margin (dB)	Limit (dBuV/m)	Remark (QP/PK/AV)
1	* 2363.800	26.99	32.18	59.17	-14.83	74.00	Peak
2	2390.000	24.81	32.30	57.10	-16.90	74.00	Peak
3	2479.700	66.11	32.69	98.80	N/A	N/A	Peak
4	2483.500	25.26	32.71	57.97	-16.03	74.00	Peak
5	2492.200	26.25	32.75	59.00	-15.00	74.00	Peak

Note:

1. " \*", means this data is the worst emission level.
2. C.F (Correction Factor) = Antenna Factor (dB) + Cable Loss (dB).
3. Measurement(dBuV/m) = Reading(dBuV) + C.F (Correction Factor).
4. The emission levels of other frequencies are very lower than the limit and not show in test report.

EUT	ACCESS POINT	Date of Test	2021-03-10
Factor	BBHA 9120D	Temp. / Humidity	21.8°C/35%
Polarity	Vertical	Site / Test Engineer	AC1 / Jay Chu
Test Mode	Transmit by BLE at Channel 2480MHz -1Mbps	Test Voltage	120V/60Hz

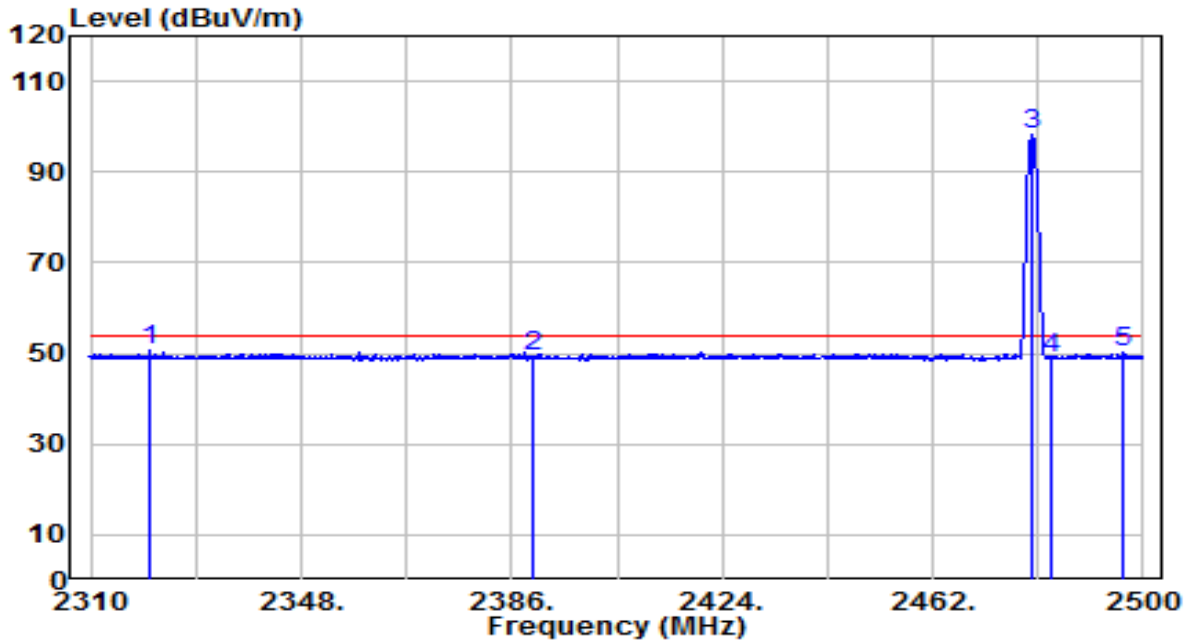

No	Frequency (MHz)	Reading (dBUV)	C.F (dB)	Measurement (dBUV/m)	Margin (dB)	Limit (dBUV/m)	Remark (QP/PK/AV)
1	* 2320.700	18.71	31.99	50.70	-3.30	54.00	AV
2	2390.000	16.89	32.30	49.19	-4.81	54.00	AV
3	2480.000	65.49	32.69	98.18	N/A	N/A	AV
4	2483.500	16.35	32.71	49.06	-4.94	54.00	AV
5	2496.500	17.41	32.76	50.17	-3.83	54.00	AV

Note:

1. " \*", means this data is the worst emission level.
2. C.F (Correction Factor) = Antenna Factor (dB) + Cable Loss (dB).
3. Measurement(dBUV/m) = Reading(dBUV) + C.F (Correction Factor).
4. The emission levels of other frequencies are very lower than the limit and not show in test report.

EUT	ACCESS POINT	Date of Test	2021-03-10
Factor	BBHA 9120D	Temp. / Humidity	21.8°C/35%
Polarity	Horizontal	Site / Test Engineer	AC1 / Jay Chu
Test Mode	Transmit by BLE at Channel 2402MHz -2Mbps	Test Voltage	120V/60Hz

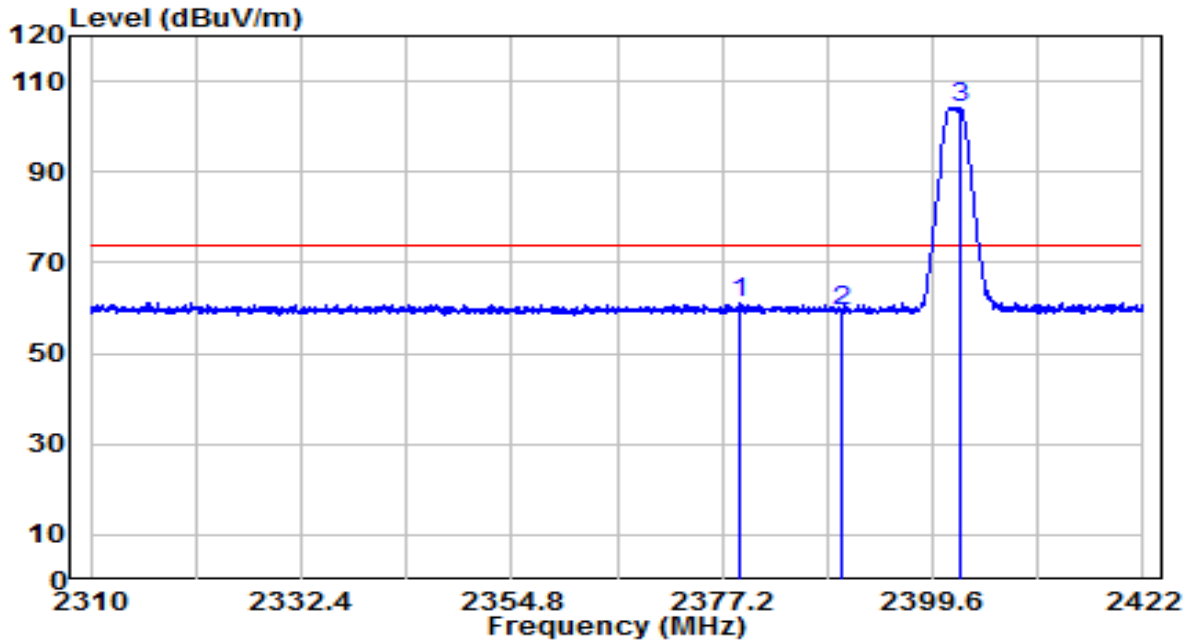

No	Frequency (MHz)	Reading (dBuV)	C.F (dB)	Measurement (dBuV/m)	Margin (dB)	Limit (dBuV/m)	Remark (QP/PK/AV)
1	*	28.79	32.25	61.04	-12.96	74.00	Peak
2		26.88	32.30	59.18	-14.82	74.00	Peak
3		71.90	32.35	104.25	N/A	N/A	Peak

Note:

1. " \*", means this data is the worst emission level.
2. C.F (Correction Factor) = Antenna Factor (dB) + Cable Loss (dB).
3. Measurement(dBuV/m) = Reading(dBuV) + C.F (Correction Factor).
4. The emission levels of other frequencies are very lower than the limit and not show in test report.

EUT	ACCESS POINT	Date of Test	2021-03-10
Factor	BBHA 9120D	Temp. / Humidity	21.8°C/35%
Polarity	Horizontal	Site / Test Engineer	AC1 / Jay Chu
Test Mode	Transmit by BLE at Channel 2402MHz -2Mbps	Test Voltage	120V/60Hz

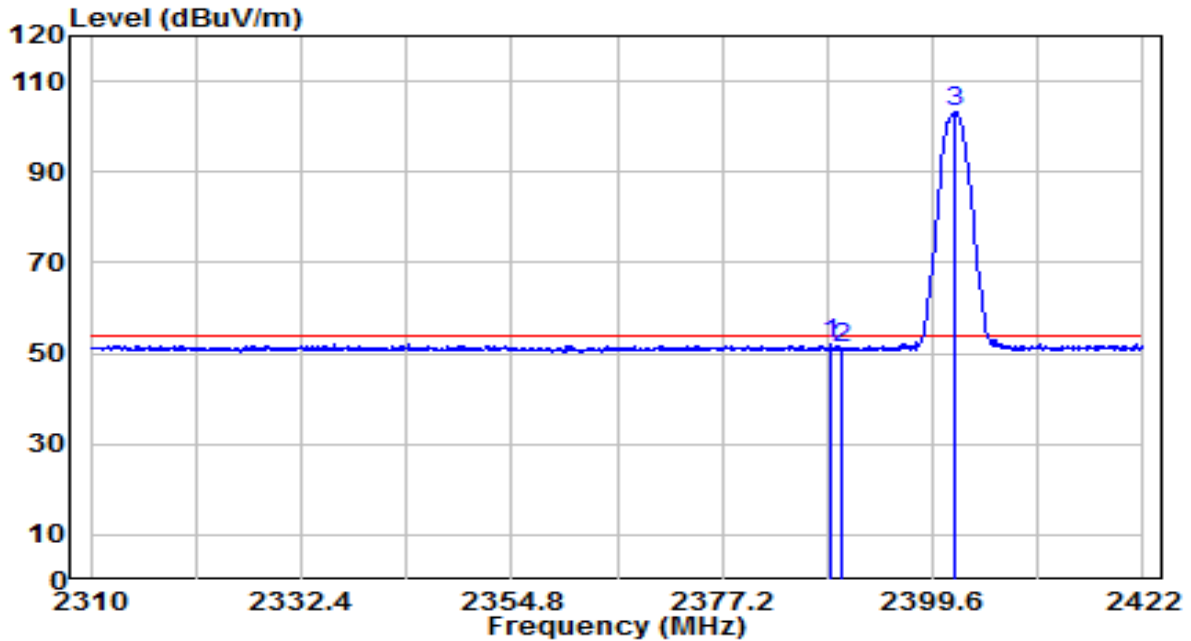

No	Frequency (MHz)	Reading (dBuV)	C.F (dB)	Measurement (dBuV/m)	Margin (dB)	Limit (dBuV/m)	Remark (QP/PK/AV)
1	*	19.63	32.29	51.92	-2.08	54.00	AV
2		18.94	32.30	51.23	-2.77	54.00	AV
3		70.93	32.35	103.28	N/A	N/A	AV

Note:

1. " \*", means this data is the worst emission level.
2. C.F (Correction Factor) = Antenna Factor (dB) + Cable Loss (dB).
3. Measurement(dBuV/m) = Reading(dBuV) + C.F (Correction Factor).
4. The emission levels of other frequencies are very lower than the limit and not show in test report.



EUT	ACCESS POINT	Date of Test	2021-03-10
Factor	BBHA 9120D	Temp. / Humidity	21.8°C/35%
Polarity	Vertical	Site / Test Engineer	AC1 / Jay Chu
Test Mode	Transmit by BLE at Channel 2402MHz -2Mbps	Test Voltage	120V/60Hz

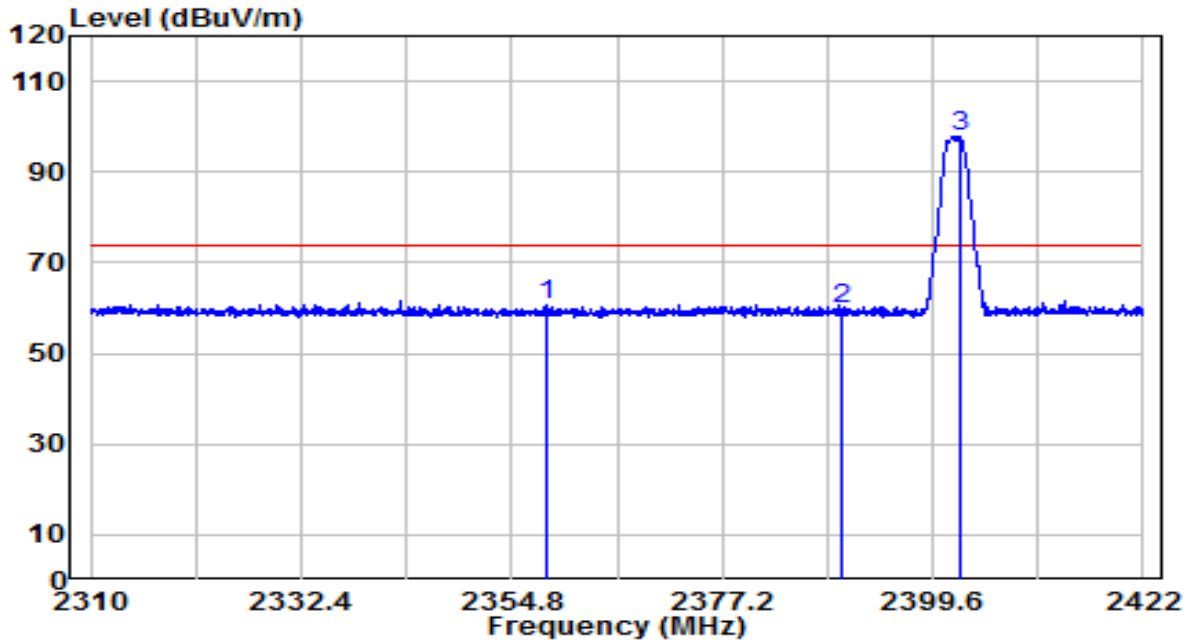

No	Frequency (MHz)	Reading (dBuV)	C.F (dB)	Measurement (dBuV/m)	Margin (dB)	Limit (dBuV/m)	Remark (QP/PK/AV)
1	*	28.48	32.16	60.64	-13.36	74.00	Peak
2		27.57	32.30	59.86	-14.14	74.00	Peak
3		65.56	32.35	97.91	N/A	N/A	Peak

Note:

1. " \*", means this data is the worst emission level.
2. C.F (Correction Factor) = Antenna Factor (dB) + Cable Loss (dB).
3. Measurement(dBuV/m) = Reading(dBuV) + C.F (Correction Factor).
4. The emission levels of other frequencies are very lower than the limit and not show in test report.

EUT	ACCESS POINT	Date of Test	2021-03-10
Factor	BBHA 9120D	Temp. / Humidity	21.8°C/35%
Polarity	Vertical	Site / Test Engineer	AC1 / Jay Chu
Test Mode	Transmit by BLE at Channel 2402MHz -2Mbps	Test Voltage	120V/60Hz

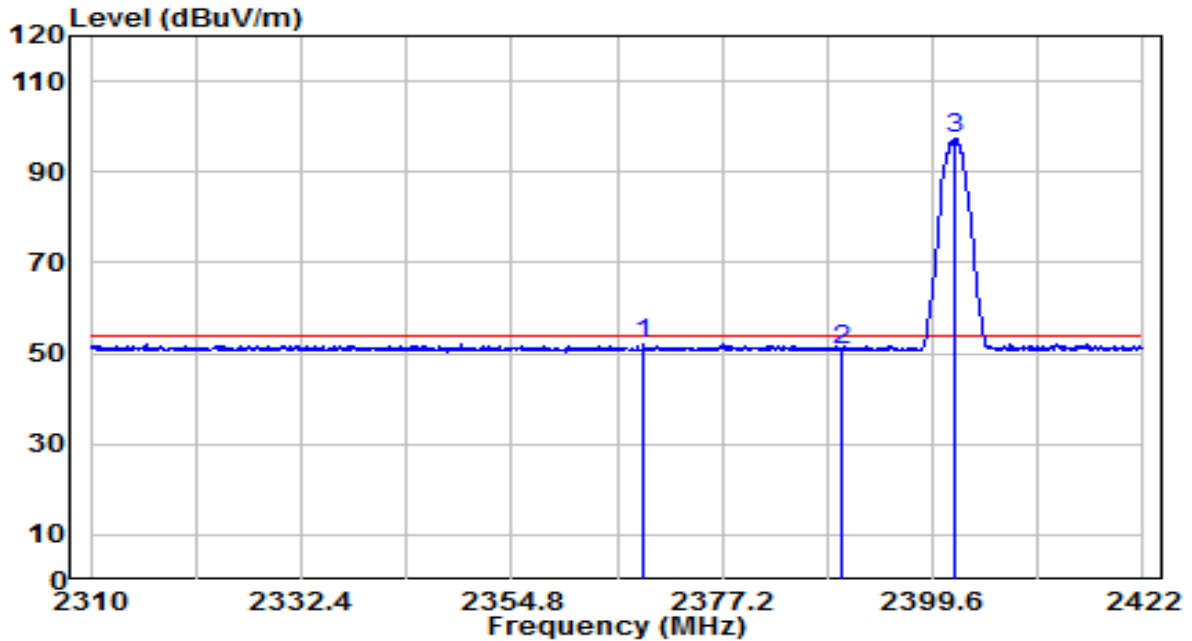

No	Frequency (MHz)	Reading (dBuV)	C.F (dB)	Measurement (dBuV/m)	Margin (dB)	Limit (dBuV/m)	Remark (QP/PK/AV)	
1	*	2368.800	19.82	32.20	52.02	-1.98	54.00	AV
2		2390.000	18.52	32.30	50.81	-3.19	54.00	AV
3		2401.952	64.95	32.35	97.30	N/A	N/A	AV

Note:

1. " \*", means this data is the worst emission level.
2. C.F (Correction Factor) = Antenna Factor (dB) + Cable Loss (dB).
3. Measurement(dBuV/m) = Reading(dBuV) + C.F (Correction Factor).
4. The emission levels of other frequencies are very lower than the limit and not show in test report.

EUT	ACCESS POINT	Date of Test	2021-03-10
Factor	BBHA 9120D	Temp. / Humidity	21.8°C/35%
Polarity	Horizontal	Site / Test Engineer	AC1 / Jay Chu
Test Mode	Transmit by BLE at Channel 2480MHz -2Mbps	Test Voltage	120V/60Hz

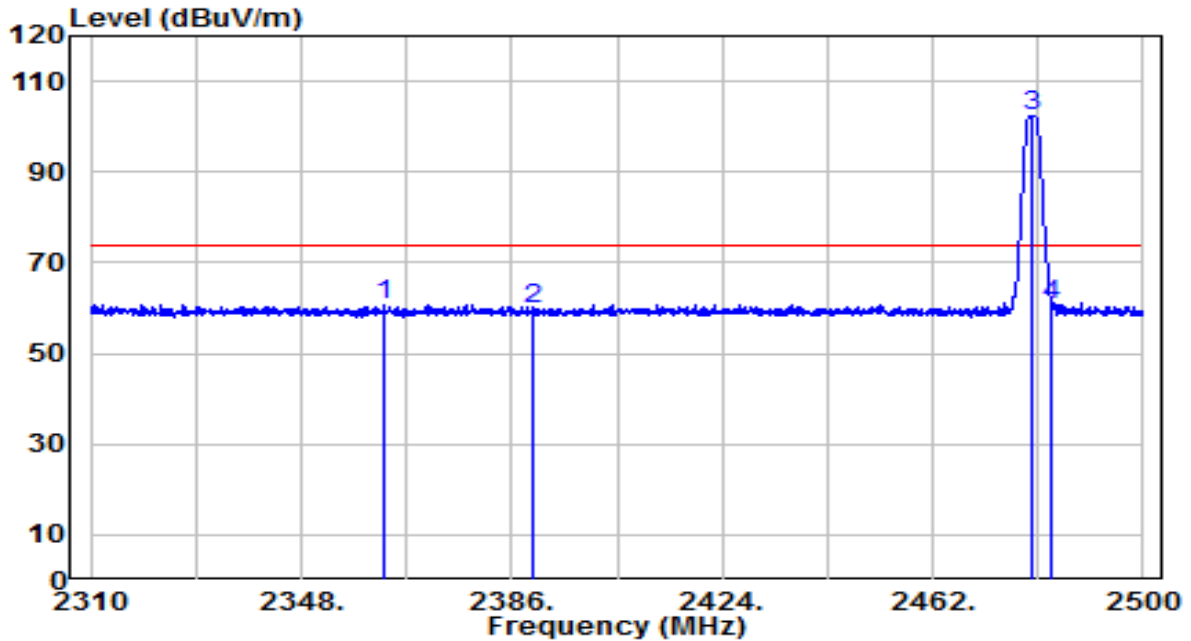

No	Frequency (MHz)	Reading (dBuV)	C.F (dB)	Measurement (dBuV/m)	Margin (dB)	Limit (dBuV/m)	Remark (QP/PK/AV)
1	*	28.63	32.18	60.81	-13.19	74.00	Peak
2		27.69	32.30	59.99	-14.01	74.00	Peak
3		69.81	32.69	102.50	N/A	N/A	Peak
4		27.92	32.71	60.63	-13.37	74.00	Peak

Note:

- "\*" means this data is the worst emission level.
- C.F (Correction Factor) = Antenna Factor (dB) + Cable Loss (dB).
- Measurement(dBuV/m) = Reading(dBuV) + C.F (Correction Factor).
- The emission levels of other frequencies are very lower than the limit and not show in test report.

EUT	ACCESS POINT	Date of Test	2021-03-10
Factor	BBHA 9120D	Temp. / Humidity	21.8°C/35%
Polarity	Horizontal	Site / Test Engineer	AC1 / Jay Chu
Test Mode	Transmit by BLE at Channel 2480MHz -2Mbps	Test Voltage	120V/60Hz

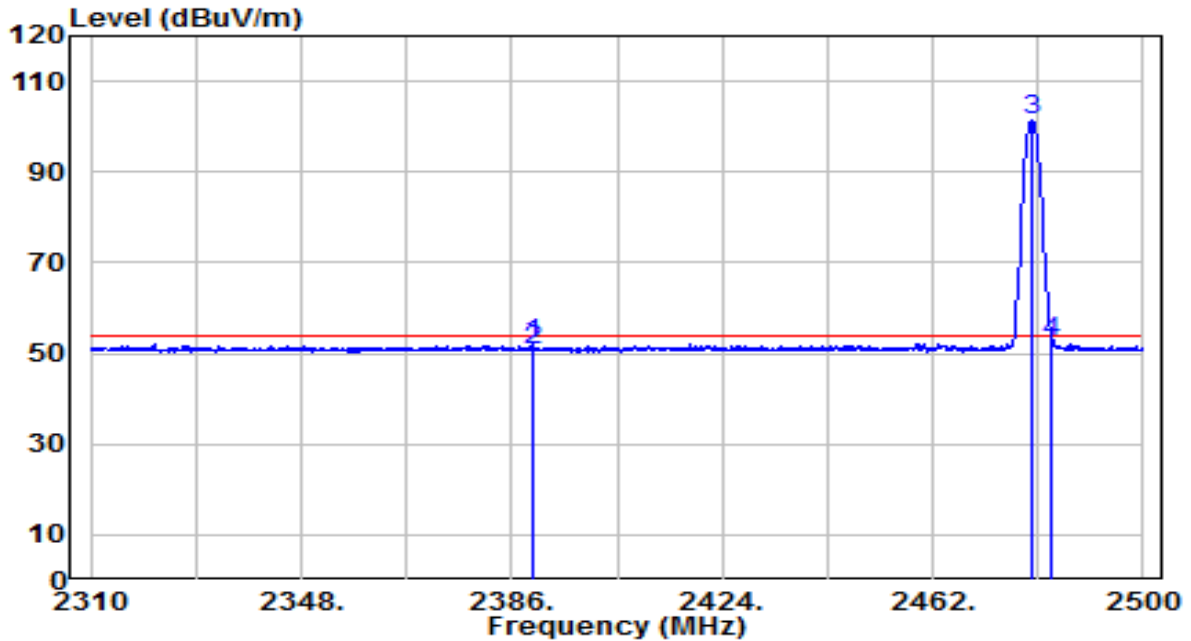

No	Frequency (MHz)	Reading (dBuV)	C.F (dB)	Measurement (dBuV/m)	Margin (dB)	Limit (dBuV/m)	Remark (QP/PK/AV)
1	2389.610	19.59	32.29	51.89	-2.11	54.00	AV
2	2390.000	18.40	32.30	50.70	-3.30	54.00	AV
3	2479.955	68.94	32.69	101.63	N/A	N/A	AV
4	* 2483.500	19.92	32.71	52.63	-1.37	54.00	AV

Note:

1. " \*", means this data is the worst emission level.
2. C.F (Correction Factor) = Antenna Factor (dB) + Cable Loss (dB).
3. Measurement(dBuV/m) = Reading(dBuV) + C.F (Correction Factor).
4. The emission levels of other frequencies are very lower than the limit and not show in test report.

EUT	ACCESS POINT	Date of Test	2021-03-10
Factor	BBHA 9120D	Temp. / Humidity	21.8°C/35%
Polarity	Vertical	Site / Test Engineer	AC1 / Jay Chu
Test Mode	Transmit by BLE at Channel 2480MHz -2Mbps	Test Voltage	120V/60Hz

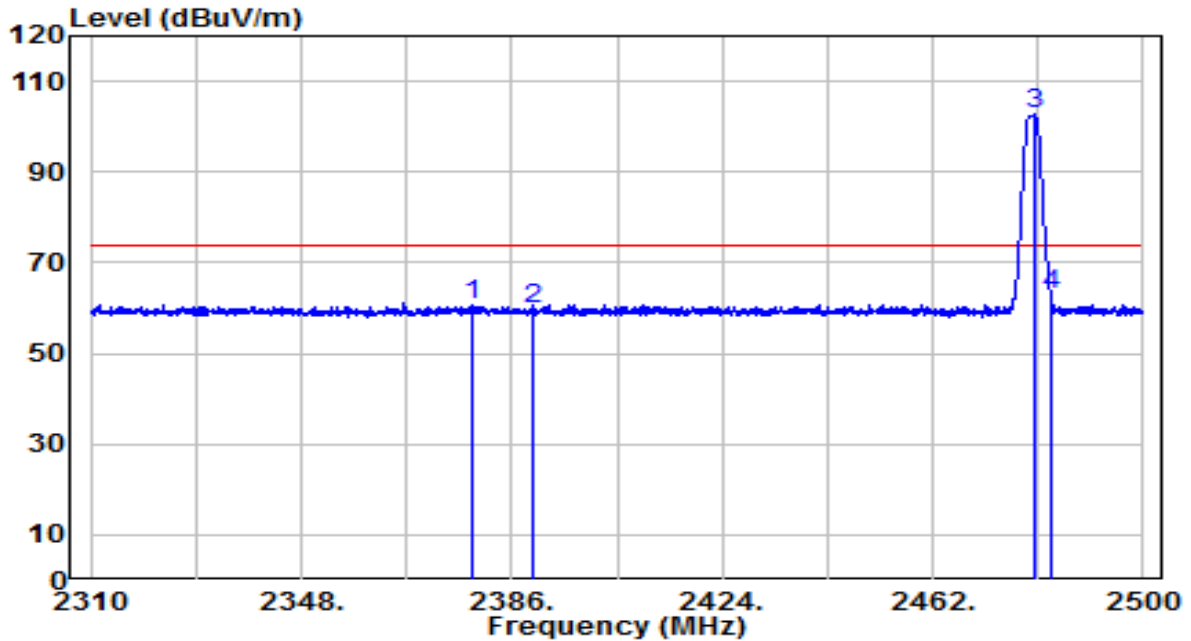

No	Frequency (MHz)	Reading (dBuV)	C.F (dB)	Measurement (dBuV/m)	Margin (dB)	Limit (dBuV/m)	Remark (QP/PK/AV)
1	2378.780	28.47	32.25	60.72	-13.28	74.00	Peak
2	2390.000	27.35	32.30	59.64	-14.36	74.00	Peak
3	2480.525	69.93	32.69	102.63	N/A	N/A	Peak
4	* 2483.500	30.15	32.71	62.86	-11.14	74.00	Peak

Note:

- "\*" means this data is the worst emission level.
- C.F (Correction Factor) = Antenna Factor (dB) + Cable Loss (dB).
- Measurement(dBuV/m) = Reading(dBuV) + C.F (Correction Factor).
- The emission levels of other frequencies are very lower than the limit and not show in test report.

EUT	ACCESS POINT	Date of Test	2021-03-10
Factor	BBHA 9120D	Temp. / Humidity	21.8°C/35%
Polarity	Vertical	Site / Test Engineer	AC1 / Jay Chu
Test Mode	Transmit by BLE at Channel 2480MHz -2Mbps	Test Voltage	120V/60Hz

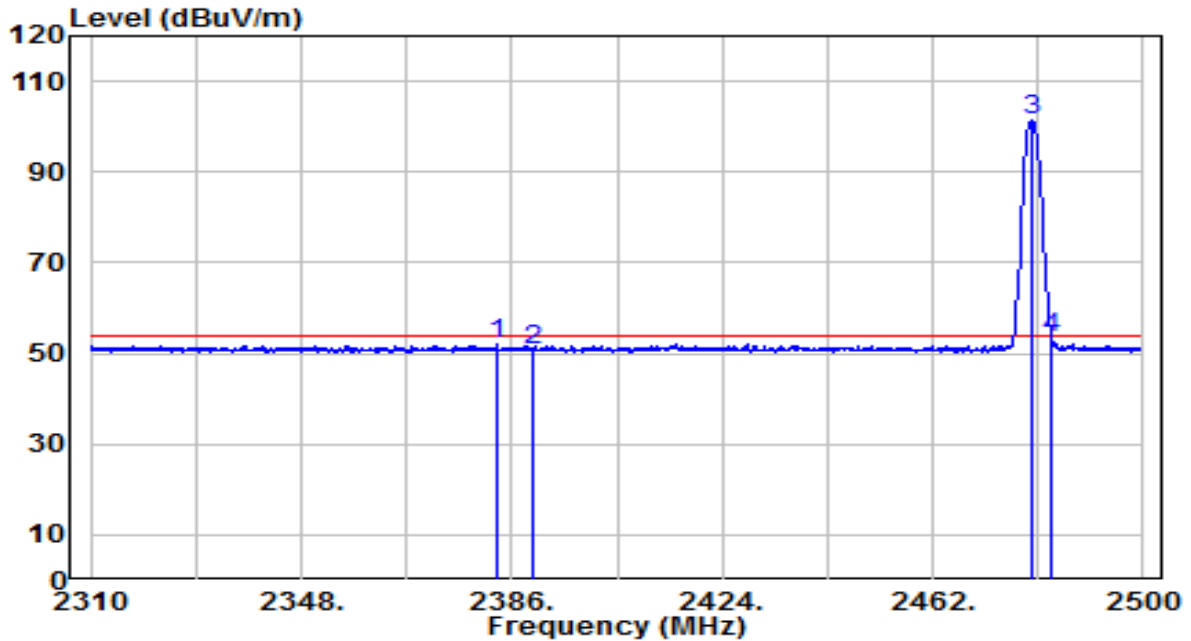

No	Frequency (MHz)	Reading (dBuV)	C.F (dB)	Measurement (dBuV/m)	Margin (dB)	Limit (dBuV/m)	Remark (QP/PK/AV)
1	2383.340	19.70	32.27	51.97	-2.03	54.00	AV
2	2390.000	18.49	32.30	50.79	-3.21	54.00	AV
3	2479.955	68.95	32.69	101.64	N/A	N/A	AV
4	* 2483.500	20.52	32.71	53.23	-0.77	54.00	AV

Note:

1. " \*", means this data is the worst emission level.
2. C.F (Correction Factor) = Antenna Factor (dB) + Cable Loss (dB).
3. Measurement(dBuV/m) = Reading(dBuV) + C.F (Correction Factor).
4. The emission levels of other frequencies are very lower than the limit and not show in test report.

**Filter Configuration 5#**

EUT	ACCESS POINT	Date of Test	2021-05-06
Factor	BBHA 9120D	Temp. / Humidity	23.2°C/33%
Polarity	Horizontal	Site / Test Engineer	AC1 / Jay Chu
Test Mode	Transmit by BLE at Channel 2402MHz -2Mbps	Test Voltage	120V/60Hz

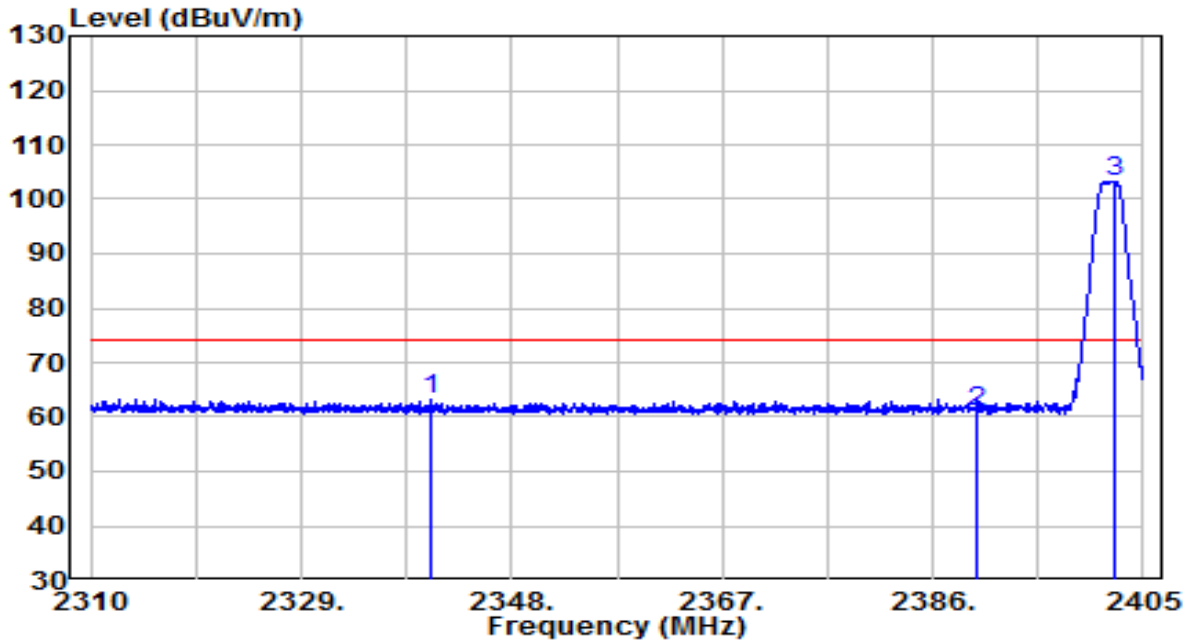

No	Frequency (MHz)	Reading (dBuV)	C.F (dB)	Measurement (dBuV/m)	Margin (dB)	Limit (dBuV/m)	Remark (QP/PK/AV)	
1	*	2340.685	31.08	32.08	63.16	-10.84	74.00	Peak
2		2390.000	28.77	32.30	61.07	-12.93	74.00	Peak
3		2402.482	71.03	32.35	103.38	N/A	N/A	Peak

Note:

1. " \*", means this data is the worst emission level.
2. C.F (Correction Factor) = Antenna Factor (dB)+ Cable Loss (dB)
3. Measurement(dBuV/m) = Reading(dBuV) + C.F (Correction Factor).
4. The emission levels of other frequencies are very lower than the limit and not show in test report.
5. For filter 5#, the worst case was performed in the report.

EUT	ACCESS POINT	Date of Test	2021-05-06
Factor	BBHA 9120D	Temp. / Humidity	23.2°C/33%
Polarity	Horizontal	Site / Test Engineer	AC1 / Jay Chu
Test Mode	Transmit by BLE at Channel 2402MHz -2Mbps	Test Voltage	120V/60Hz

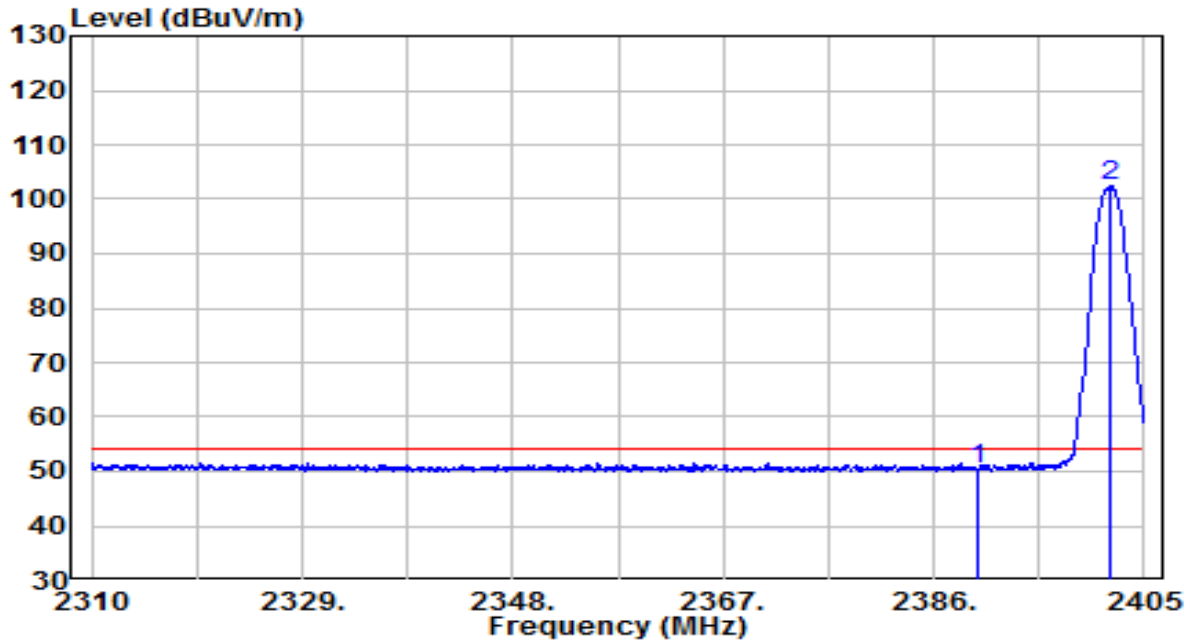

No	Frequency (MHz)	Reading (dBuV)	C.F (dB)	Measurement (dBuV/m)	Margin (dB)	Limit (dBuV/m)	Remark (QP/PK/AV)	
1	*	2390.000	18.02	32.30	50.32	-3.68	54.00	AV
2		2402.008	70.13	32.35	102.48	N/A	N/A	AV

Note:

1. " \*", means this data is the worst emission level.
2. C.F (Correction Factor) = Antenna Factor (dB)+ Cable Loss (dB)
3. Measurement(dBuV/m) = Reading(dBuV) + C.F (Correction Factor).
4. The emission levels of other frequencies are very lower than the limit and not show in test report.
5. For filter 5#, the worst case was performed in the report.



EUT	ACCESS POINT	Date of Test	2021-05-06
Factor	BBHA 9120D	Temp. / Humidity	23.2°C/33%
Polarity	Vertical	Site / Test Engineer	AC1 / Jay Chu
Test Mode	Transmit by BLE at Channel 2402MHz -2Mbps	Test Voltage	120V/60Hz

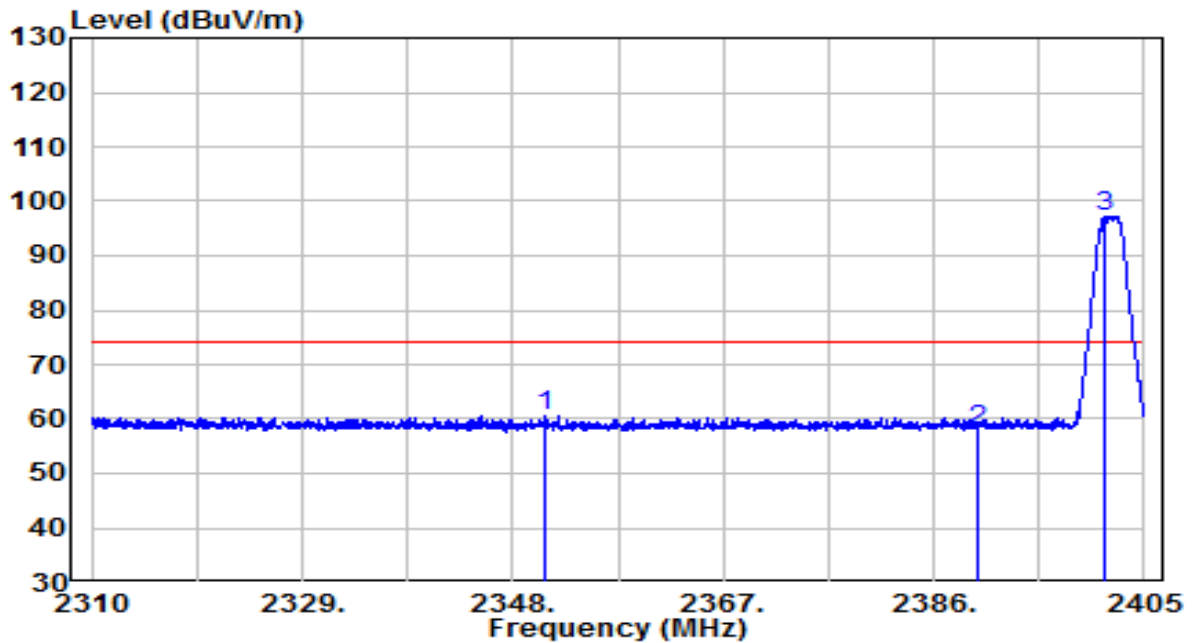

No	Frequency (MHz)	Reading (dBuV)	C.F (dB)	Measurement (dBuV/m)	Margin (dB)	Limit (dBuV/m)	Remark (QP/PK/AV)
1	*	28.39	32.12	60.52	-13.48	74.00	Peak
2		25.79	32.30	58.09	-15.91	74.00	Peak
3		64.87	32.35	97.22	N/A	N/A	Peak

Note:

1. " \*", means this data is the worst emission level.
2. C.F (Correction Factor) = Antenna Factor (dB)+ Cable Loss (dB)
3. Measurement(dBuV/m) = Reading(dBuV) + C.F (Correction Factor).
4. The emission levels of other frequencies are very lower than the limit and not show in test report.
5. For filter 5#, the worst case was performed in the report.

EUT	ACCESS POINT	Date of Test	2021-05-06
Factor	BBHA 9120D	Temp. / Humidity	23.2°C/33%
Polarity	Vertical	Site / Test Engineer	AC1 / Jay Chu
Test Mode	Transmit by BLE at Channel 2402MHz -2Mbps	Test Voltage	120V/60Hz

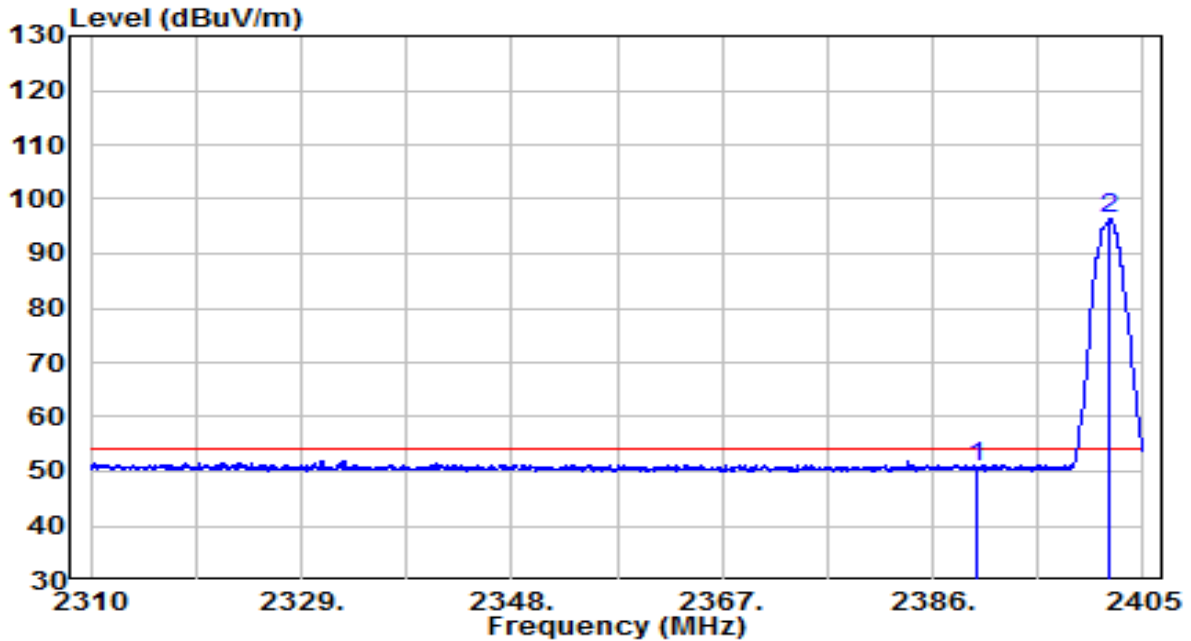

No	Frequency (MHz)	Reading (dBUV)	C.F (dB)	Measurement (dBUV/m)	Margin (dB)	Limit (dBUV/m)	Remark (QP/PK/AV)
1	* 2390.000	18.35	32.30	50.65	-3.35	54.00	AV
2	2402.008	63.89	32.35	96.24	N/A	N/A	AV

Note:

1. " \*", means this data is the worst emission level.
2. C.F (Correction Factor) = Antenna Factor (dB)+ Cable Loss (dB)
3. Measurement(dBUV/m) = Reading(dBUV) + C.F (Correction Factor).
4. The emission levels of other frequencies are very lower than the limit and not show in test report.
5. For filter 5#, the worst case was performed in the report.

**Filter Configuration 6#**

EUT	ACCESS POINT	Date of Test	2021-05-06
Factor	BBHA 9120D	Temp. / Humidity	23.2°C/33%
Polarity	Horizontal	Site / Test Engineer	AC1 / Jay Chu
Test Mode	Transmit by BLE at Channel 2480MHz -2Mbps	Test Voltage	120V/60Hz

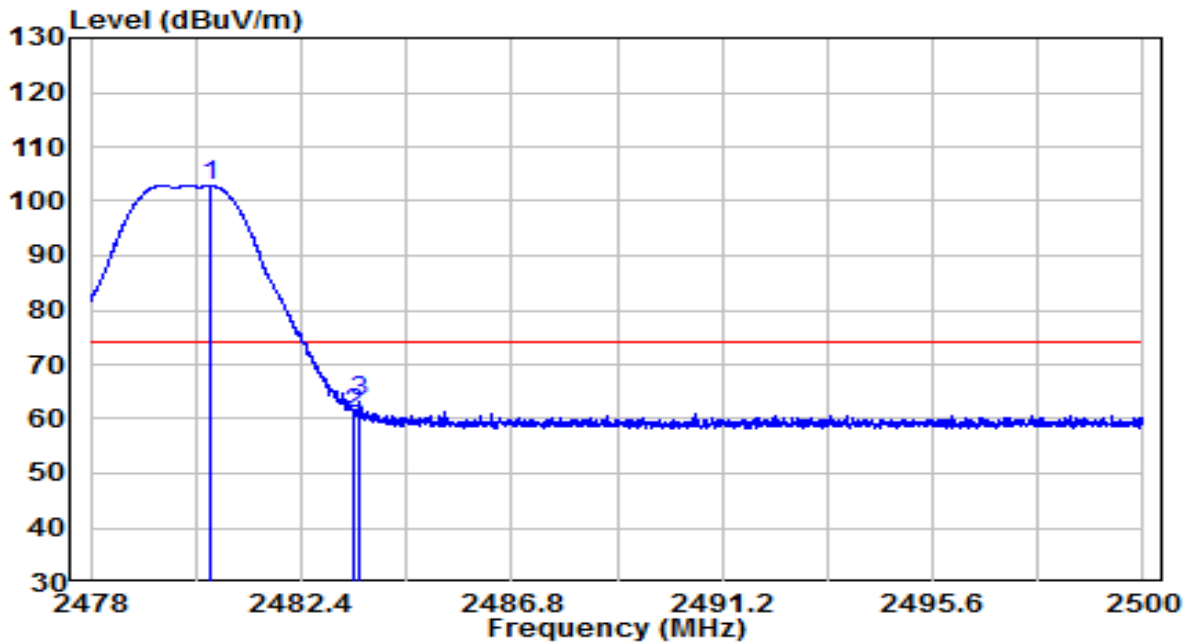

No	Frequency (MHz)	Reading (dBUV)	C.F (dB)	Measurement (dBUV/m)	Margin (dB)	Limit (dBUV/m)	Remark (QP/PK/AV)
1	2480.486	70.20	32.69	102.90	N/A	N/A	Peak
2	2483.500	28.17	32.71	60.87	-13.13	74.00	Peak
3	* 2483.610	30.46	32.71	63.17	-10.83	74.00	Peak

**Note:**

- "\*", means this data is the worst emission level.
- C.F (Correction Factor) = Antenna Factor (dB)+ Cable Loss (dB)
- Measurement(dBUV/m) = Reading(dBUV) + C.F (Correction Factor).
- The emission levels of other frequencies are very lower than the limit and not show in test report.
- For filter 6#, the worst case was performed in the report.

EUT	ACCESS POINT	Date of Test	2021-05-06
Factor	BBHA 9120D	Temp. / Humidity	23.2°C/33%
Polarity	Horizontal	Site / Test Engineer	AC1 / Jay Chu
Test Mode	Transmit by BLE at Channel 2480MHz -2Mbps	Test Voltage	120V/60Hz

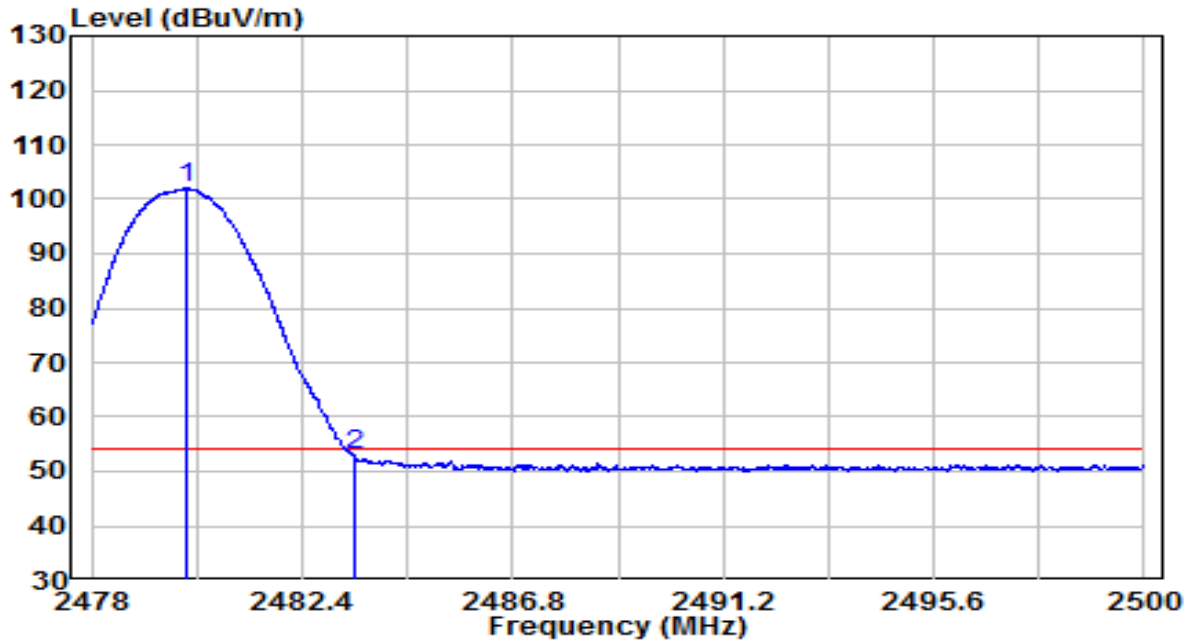

No	Frequency (MHz)	Reading (dBuV)	C.F (dB)	Measurement (dBuV/m)	Margin (dB)	Limit (dBuV/m)	Remark (QP/PK/AV)
1	2479.958	69.22	32.69	101.92	N/A	N/A	AV
2	* 2483.500	20.24	32.71	52.94	-1.06	54.00	AV

Note:

1. " \*", means this data is the worst emission level.
2. C.F (Correction Factor) = Antenna Factor (dB)+ Cable Loss (dB)
3. Measurement(dBuV/m) = Reading(dBuV) + C.F (Correction Factor).
4. The emission levels of other frequencies are very lower than the limit and not show in test report.
5. For filter 6#, the worst case was performed in the report.

EUT	ACCESS POINT	Date of Test	2021-05-06
Factor	BBHA 9120D	Temp. / Humidity	23.2°C/33%
Polarity	Vertical	Site / Test Engineer	AC1 / Jay Chu
Test Mode	Transmit by BLE at Channel 2480MHz -2Mbps	Test Voltage	120V/60Hz

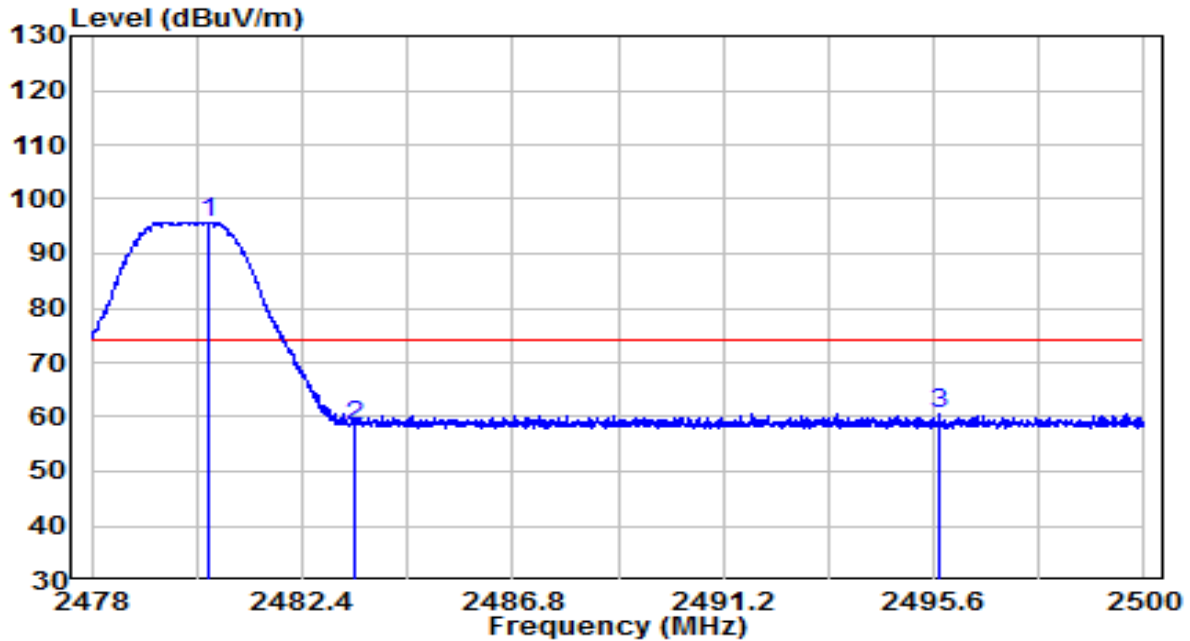

No	Frequency (MHz)	Reading (dBUV)	C.F (dB)	Measurement (dBUV/m)	Margin (dB)	Limit (dBUV/m)	Remark (QP/PK/AV)
1	2480.431	63.15	32.69	95.84	N/A	N/A	Peak
2	2483.500	25.76	32.71	58.47	-15.53	74.00	Peak
3	* 2495.699	27.79	32.76	60.55	-13.45	74.00	Peak

Note:

1. " \*", means this data is the worst emission level.
2. C.F (Correction Factor) = Antenna Factor (dB)+ Cable Loss (dB)
3. Measurement(dBUV/m) = Reading(dBUV) + C.F (Correction Factor).
- 4.The emission levels of other frequencies are very lower than the limit and not show in test report.
5. For filter 6#, the worst case was performed in the report.

EUT	ACCESS POINT	Date of Test	2021-05-06
Factor	BBHA 9120D	Temp. / Humidity	23.2°C/33%
Polarity	Vertical	Site / Test Engineer	AC1 / Jay Chu
Test Mode	Transmit by BLE at Channel 2480MHz -2Mbps	Test Voltage	120V/60Hz

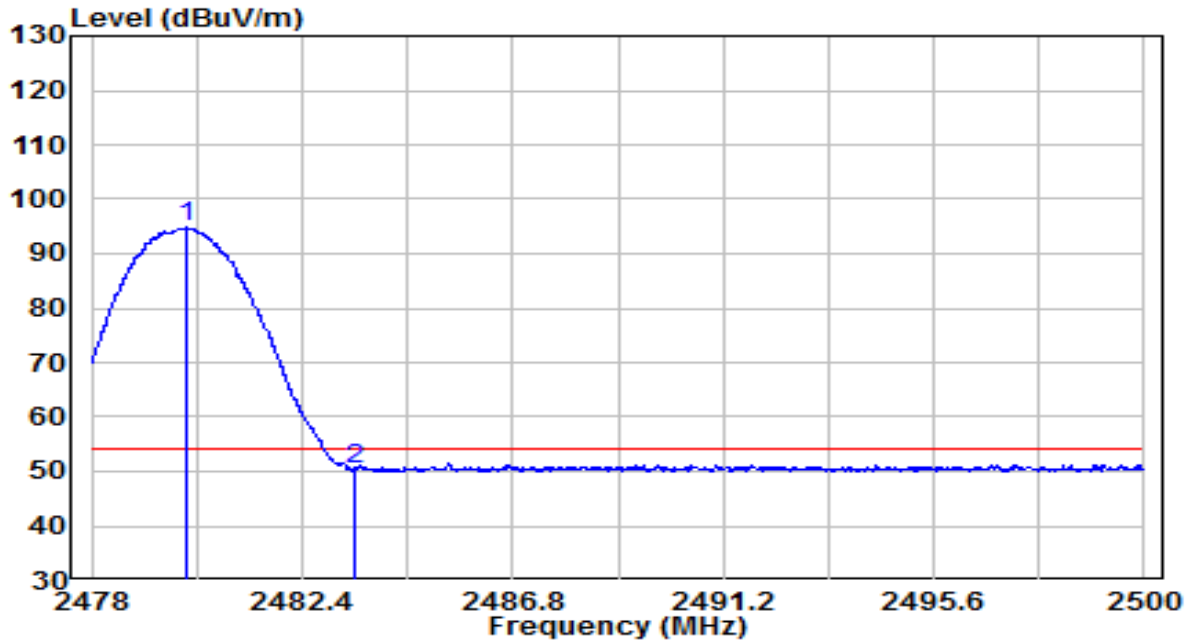

No	Frequency (MHz)	Reading (dBuV)	C.F (dB)	Measurement (dBuV/m)	Margin (dB)	Limit (dBuV/m)	Remark (QP/PK/AV)
1	2479.980	62.07	32.69	94.76	N/A	N/A	AV
2	* 2483.500	17.78	32.71	50.49	-3.51	54.00	AV

Note:

1. " \*", means this data is the worst emission level.
2. C.F (Correction Factor) = Antenna Factor (dB)+ Cable Loss (dB)
3. Measurement(dBuV/m) = Reading(dBuV) + C.F (Correction Factor).
4. The emission levels of other frequencies are very lower than the limit and not show in test report.
5. For filter 6#, the worst case was performed in the report.

## 7.8. AC Conducted Emissions Measurement

### 7.8.1. Test Limit

FCC Part 15 Subpart C Paragraph 15.207 Limits		
Frequency (MHz)	QP (dBuV)	AV (dBuV)
0.15 - 0.50	66 - 56	56 - 46
0.50 - 5.0	56	46
5.0 - 30	60	50

Note 1: The lower limit shall apply at the transition frequencies.

Note 2: The limit decreases linearly with the logarithm of the frequency in the range 0.15MHz to 0.5MHz.

### 7.8.2. Test Setup

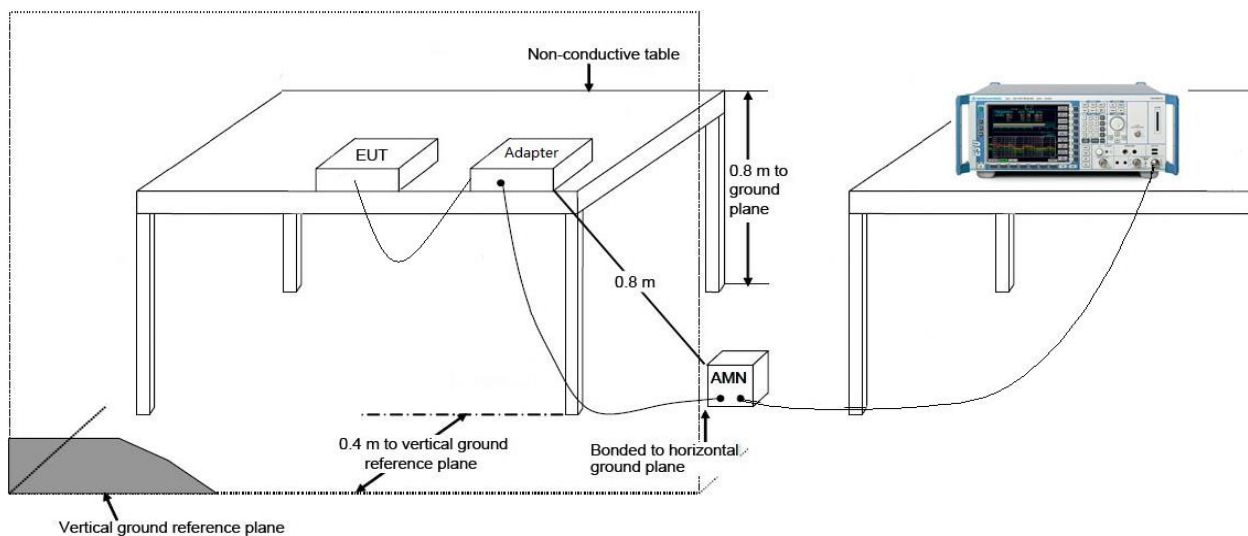

### 7.8.3. Test Result

EUT	ACCESS POINT	Date of Test	2021-04-27
Factor	CE_ENV216-L1 (Filter ON)	Temp. / Humidity	23.6°C/60.9%
Polarity	Line1	Site / Test Engineer	SR2 / Eric Lin
Test Mode	Transmit by BLE at channel 2442MHz -1Mbps	Test Voltage	120V/60Hz

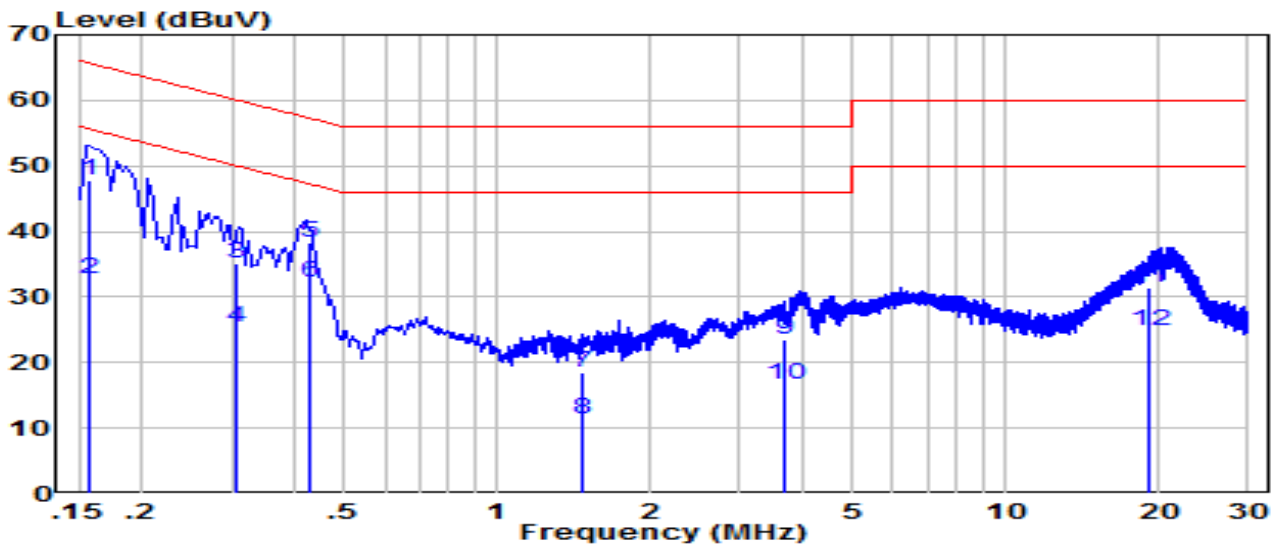

No	Frequency (MHz)	Reading (dBUV)	C.F (dB)	Measurement (dBUV/m)	Margin (dB)	Limit (dBUV/m)	Remark (QP/PK/AV)
1	0.158	38.33	9.61	47.94	-17.63	65.57	QP
2	0.158	23.23	9.61	32.84	-22.73	55.57	Average
3	0.306	25.45	9.62	35.07	-25.00	60.08	QP
4	0.306	15.75	9.62	25.37	-24.70	50.08	Average
5	0.426	28.56	9.63	38.19	-19.14	57.33	QP
6	* 0.426	22.66	9.63	32.29	-15.04	47.33	Average
7	1.460	8.79	9.67	18.46	-37.54	56.00	QP
8	1.460	1.59	9.67	11.26	-34.74	46.00	Average
9	3.650	13.82	9.71	23.53	-32.47	56.00	QP
10	3.650	6.92	9.71	16.63	-29.37	46.00	Average
11	19.180	21.43	9.98	31.41	-28.59	60.00	QP
12	19.180	14.93	9.98	24.91	-25.09	50.00	Average

Note:

1. " \*", means this data is the worst emission level.
2. C.F (Correction Factor) = LISN Factor (dB)+ Cable Loss (dB).
3. Measurement(dBUV/m) = Reading(dBUV) + C.F (Correction Factor).



EUT	ACCESS POINT	Date of Test	2021-04-27
Factor	CE_ENV216-N (Filter ON)	Temp. / Humidity	23.6°C/60.9%
Polarity	Neutral	Site / Test Engineer	SR2 / Eric Lin
Test Mode	Transmit by BLE at channel 2442MHz -1Mbps	Test Voltage	120V/60Hz

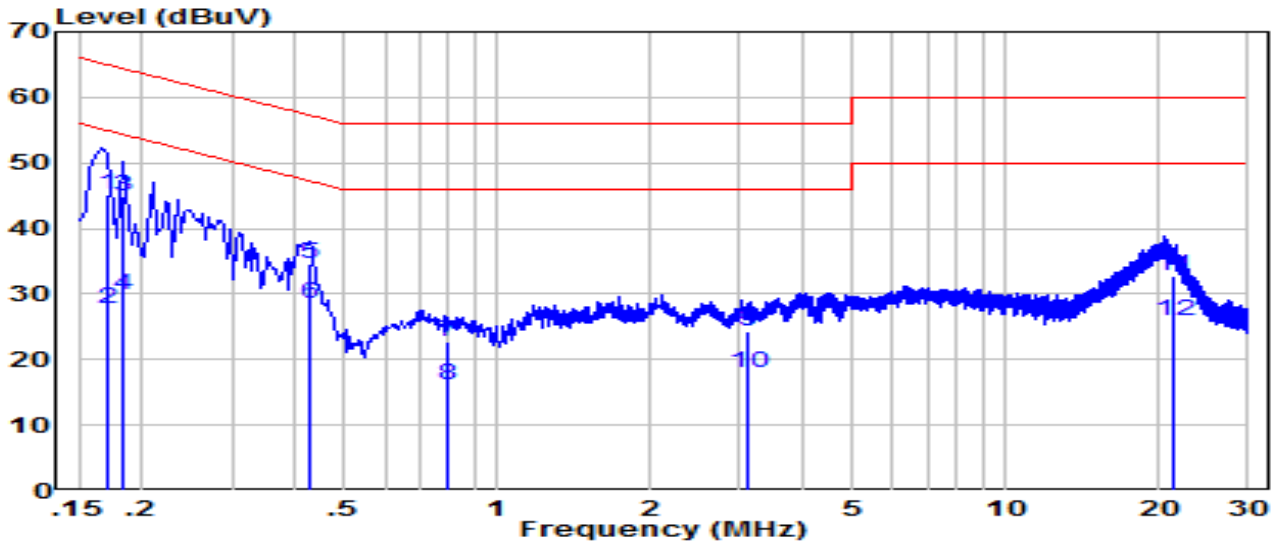

No	Frequency (MHz)	Reading (dBuV)	C.F (dB)	Measurement (dBuV/m)	Margin (dB)	Limit (dBuV/m)	Remark (QP/PK/AV)
1	0.170	35.43	9.62	45.05	-19.91	64.96	QP
2	0.170	18.23	9.62	27.85	-27.11	54.96	Average
3	0.182	35.23	9.62	44.85	-19.54	64.39	QP
4	0.182	20.13	9.62	29.75	-24.64	54.39	Average
5	0.425	25.05	9.64	34.69	-22.66	57.35	QP
6	* 0.425	18.85	9.64	28.49	-18.86	47.35	Average
7	0.797	12.98	9.66	22.64	-33.36	56.00	QP
8	0.797	6.38	9.66	16.04	-29.96	46.00	Average
9	3.120	14.70	9.71	24.41	-31.59	56.00	QP
10	3.120	8.20	9.71	17.91	-28.09	46.00	Average
11	21.340	22.63	10.09	32.72	-27.28	60.00	QP
12	21.340	15.93	10.09	26.02	-23.98	50.00	Average

Note:

1. " \*", means this data is the worst emission level.
2. C.F (Correction Factor) = LISN Factor (dB)+ Cable Loss (dB).
3. Measurement(dBuV/m) = Reading(dBuV) + C.F (Correction Factor).

## 8. CONCLUSION

The data collected relate only the item(s) tested and show that the unit is compliance with Part 15C of the FCC Rules.

\_\_\_\_\_ The End \_\_\_\_\_

## **Appendix A - Test Setup Photograph**

Refer to “2101TW0003-Test setup photo” file.

## **Appendix B - EUT Photograph**

Refer to "2101TW0003-EUT photo" file.