

Aruba 518 Series Ruggedized Access Point

Installation Guide

The Aruba 518 Series access points are high-performance, multi-radio wireless devices that can be deployed in either controller-based (ArubaOS) or controllerless (Aruba Instant) network environment.

The Aruba 518 Series access points support IEEE 802.11ax standard, delivering high performance with the MU-MIMO (Multi-User Multiple-Input, Multiple-Output) technology, while also supporting 802.11a/b/g/n/ac wireless services.

Package Contents

- 518 Series access point
- Cable gland x 2
- USB Type-C console cable x 1
- Grounding lug and M4x6 screw x 1

Tools Required

- Phillips screwdriver (#2 for M4x6 screw)
- Flat blade screwdriver (Ethernet cable gland covers)
- 8mm allen or hex key (USB console cover)



The weatherproof caps for Ethernet and Console interfaces are connected to the access point, not loose in the package.



Mounting kits for use with the 518 Series access points are sold separately. Contact your Aruba sales representative for details.



Inform your supplier if there are any incorrect, missing, or damaged parts. If possible, retain the carton, including the original packing materials. Use these materials to repack and return the unit to the supplier if needed.

Hardware Overview

Figure 1 518 Series Front View

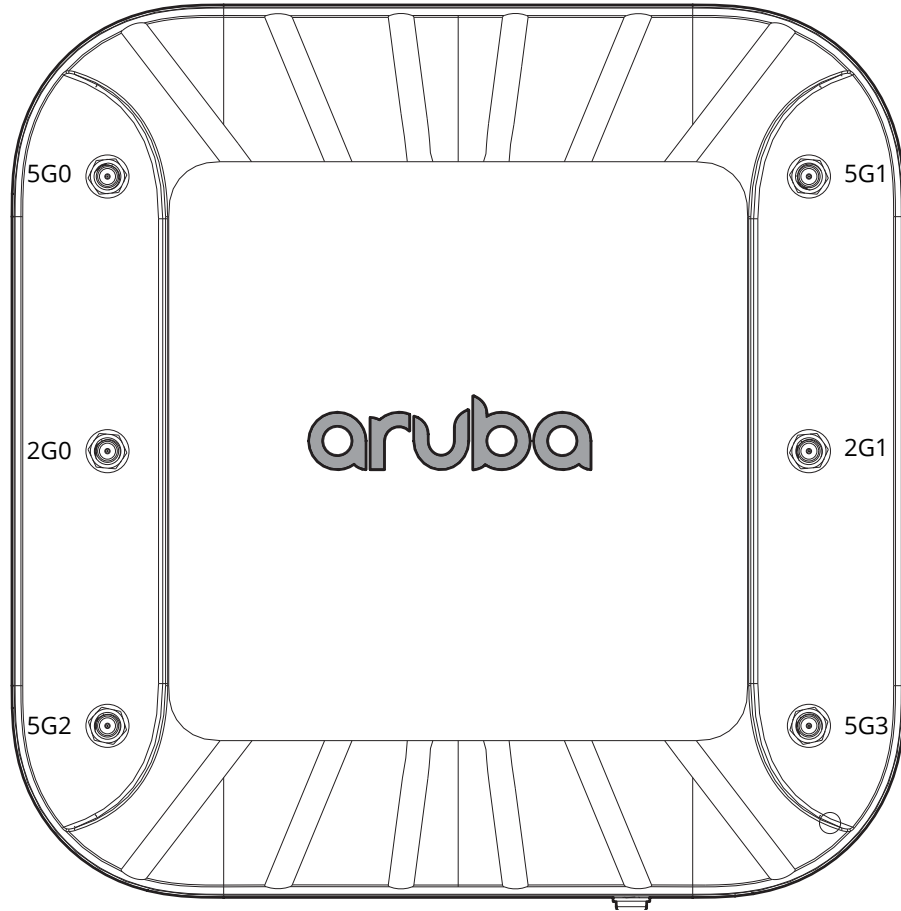
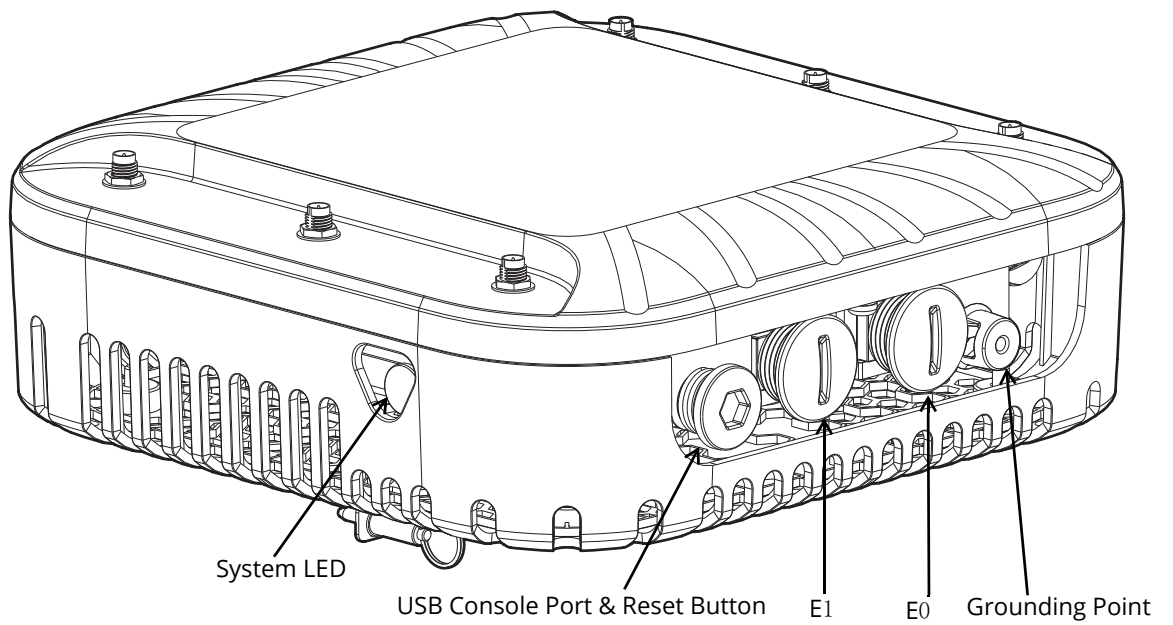

Figure 2 518 Series Bottom View



External Antenna Connectors

The AP-518 access point is equipped with six external antenna connectors. The connectors are labeled 2G0, 2G1, 5G0, 5G1, 5G2, and 5G3.

External antennas for this device must be installed by an Aruba Certified Mobility Professional (ACMP) or other Aruba-certified technician, using manufacturer-approved antennas only.

The Equivalent Isotropically Radiated Power (EIRP) levels for all external antenna devices must not exceed the regulatory limit set by the host country/domain.

Installers are required to record the antenna gain for this device in the system management software. A list of approved antennas can be found at: http://www.arubanetworks.com/assets/og/OG_AP-518Series.pdf.



Les antennes externes pour cet appareil doivent être installées par un professionnel de la mobilité certifié Aruba (ACMP) ou un autre technicien certifié Aruba, en utilisant uniquement des antennes approuvées par le fabricant. Les niveaux équivalents de puissance à rayonnement isotrope (EIRP) pour tous les périphériques d'antenne externe ne doivent pas dépasser la limite réglementaire définie par le pays hôte / domaine.

Les installateurs doivent enregistrer le gain d'antenne pour cet appareil dans le logiciel de gestion du système. Une liste d'antennes approuvées peut être trouvée à http://www.arubanetworks.com/assets/og/OG_AP-518Series.pdf.

LED

The 518 Series access point is equipped with one LED that indicates the system status of the access point.

Table 1 518 Series LED Meanings during Boot Up

LED	Color/State	Meaning
System LED	Off	No power to AP
	Red	Initial power-up
	Green - Flashing	AP booting, not ready
	Green - Steady	AP ready and Gigabit Ethernet connected. The LED turns off after 1200 seconds
	Green - Yellow, 6 seconds period	AP ready and 10/100Mbps Ethernet link established. The LED turns off after 1200 seconds

Table 2 518 Series LED Meanings during Operation

LED	Color/State	Meaning
System LED	Solid Red	General fault-Immediate attention required
	One blink off every 3 seconds	Radio 0 fault (5 GHz)
	Two quick blink off 0.5 seconds apart cycled every 3 seconds	Radio 1 fault (2.4GHz)

Ethernet Ports

The Aruba 518 Series access points are equipped with two Ethernet ports (E0 and E1):

- E0 port: 100/1000/2500Base-T auto-sensing MDI/MDX wired RJ45 network connectivity port
- E1 port: 100/1000Base-T auto-sensing MDI/MDX wired RJ45 network connectivity port

Power

Both E0 and E1 ports support PoE-in, allowing the AP to draw power from an 802.3at/802.3bt PoE power source. When the AP is powered by both E0 and E1 ports simultaneously, the AP can be configured by management software to source PoE power from either port, or to combine power from both ports.

The 518 Series access points support the Intelligent Power Monitoring (IPM) feature, to report AP power consumption and enable intelligent management of power-save capabilities.

Table 3 lists operational restrictions when the AP is powered by different power options.

Table 3 Power Options and Operational Restrictions

Power Source	IPM	Restrictions
1 x 802.3bt PoE	n/a	No restrictions, all capabilities available.
2 x 802.3at PoE	n/a	No restrictions, all capabilities available.
1 x 802.3at PoE	enabled	AP starts up in unrestricted mode, but may dynamically apply restrictions depending on the PoE budget and actual power.
1 x 802.3at PoE	disabled	Second (other) Ethernet port disabled.
1 x 802.3af PoE	n/a	AP does not start up, red system LED.

Grounding Point

Always remember to protect the access point by installing grounding lines. The ground connection must be complete before connecting power to the access point enclosure.

USB Type-C Console Port

Use the included USB Type-C console cable to connect the access point to a laptop or a serial terminal for direct management.



You need a proper 8mm allen or hex key to open the cover of the USB Console port.

Reset Button

The reset button can be used to reset the access point to factory default settings or turn off/on the LED display.

There are two ways to reset the access point to factory default settings:

Reset the AP during normal operation

Press and hold down the reset button using a small, narrow object such as a paper clip for more than 10 seconds during normal operation.

Reset the AP while powering up

1. Press and hold down the reset button using a small, narrow object such as a paper clip while the access point is not powered on via PoE.
2. Connect the power supply (PoE) to the access point while the reset button is being held down.
3. Release the reset button on the access point after 15 seconds.

To turn off/on the LED display, press and release the reset button using a small, narrow object, such as a paperclip for less than 10 seconds during normal operation of the access point.

Before You Begin

Refer to the sections below before beginning the installation process.



FCC Statement: Improper termination of access points installed in the United States configured to non-US model controllers will be in violation of the FCC grant of equipment authorization. Any such willful or intentional violation may result in a requirement by the FCC for immediate termination of operation and may be subject to forfeiture (47 CFR 1.80).

Pre-Installation Checklist

Before installing your 518 Series access point, be sure that you have the following:

- Cat5E or better UTP cable with network access
- A compatible PoE injector with power cord

One of the following network services:

- Aruba Discovery Protocol (ADP)
- DNS server with an "A" record
- DHCP Server with vendor specific options



Aruba, in compliance with governmental requirements, has designed the AP-518 access points so that only authorized network administrators can change configuration settings. For more information about AP configuration, refer to the *AP Software Quick Start Guide*.



Access points are radio transmission devices and as such are subject to governmental regulation. Network administrators responsible for the configuration and operation of access points must comply with local broadcast regulations. Specifically, access points must use channel assignments appropriate to the location in which the access point will be used.

Identifying Specific Installation Locations

Use the access point placement map generated by Aruba RF Plan software application to determine the proper installation location(s). Each location should be as close as possible to the center of the intended coverage area and should be free from obstructions or obvious sources of interference. These RF absorbers/reflectors/interference sources will impact RF propagation and should be accounted for during the planning phase and adjusted for in RF plan.

Identifying Known RF Absorbers/Reflectors/Interference Sources

Identifying known RF absorbers, reflectors, and interference sources while in the field during the installation phase is critical. Make sure that these sources are taken into consideration when you attach an access point to its fixed location.

RF absorbers include:

- Cement/concrete—Old concrete has high levels of water dissipation, which dries out the concrete, allowing for potential RF propagation. New concrete has high levels of water concentration in the concrete, blocking RF signals.
- Natural Items—Fish tanks, water fountains, ponds, and trees
- Brick

RF reflectors include:

- Metal Objects—Metal pans between floors, rebar, fire doors, air conditioning/heating ducts, mesh windows, blinds, chain link fences (depending on aperture size), refrigerators, racks, shelves, and filing cabinets.
- Do not place an access point between two air conditioning/heating ducts. Make sure that access points are placed below ducts to avoid RF disturbances.

RF interference sources include:

- Microwave ovens and other 2.4 or 5 GHz objects (such as cordless phones)
- Cordless headset such as those used in call centers or lunch rooms

Access Point Installation



Service to all Aruba products should be performed by trained service personnel only.

Using the Pre-assembled Bracket

A bracket has been pre-assembled on the back of the 518 Series access point. This bracket is used to work with the mount kits (sold separately) in [Table 4](#) to mount the AP-518 on a ceiling rail, a solid surface, or a wall-box..

Table 4 *Compatible Mount Kits for Pre-assembled Bracket*

Part Number	Description
R3J15A	AP-MNT-A Campus AP mount bracket kit (individual) type A: suspended ceiling rail, flat 9/16
R3J16A	AP-MNT-B Campus AP mount bracket kit (individual) type B: suspended ceiling rail, flat 15/16
R3J17A	AP-MNT-C Campus AP mount bracket kit (individual) type C: suspended ceiling rail, profile 9/16
R3J18A	AP-MNT-D Campus AP mount bracket kit (individual) type D: solid surface
R3J19A	AP-MNT-E Campus AP mount bracket kit (individual) type E: wall-box
R3T20A	AP-MNT-MP10-X Campus AP mount adapter kit (10-pack) for existing W2/W3 mounts



The 518 Series access point does not ship with any mount kit. These mount kits are available as accessories and must be ordered separately.



For installation instructions on AP-MNT-MP10-A, AP-MNT-MP10-B, AP-MNT-MP10-C, AP-MNT-MP10-D and AP-MNT-MP10-E mount kits, please refer to their installation guides shipped with the mount kits.

Using the AP-270-MNT-ADP Mount Adapter

You will need to remove the pre-assembled bracket to mount the AP-270-MNT-ADP adapter (sold separately) on the back of the AP-518. The AP-270-MNT-ADP adapter can work with the AP-270-MNT-XX mount kits in [Table 5](#) to mount the AP-518 to a pole or a wall.

Table 5 *Compatible Mount Kits for AP-270-MNT-ADP Adapter*

Part Number	Description
JW056A	AP-270-MNT-ADP AP-228 to AP-270-MNT-XX outdoor mount adapter
JW052A	AP-270-MNT-V1 AP-270 series outdoor pole/wall long mount kit

Table 5 *Compatible Mount Kits for AP-270-MNT-ADP Adapter*

Part Number	Description
JW053A	AP-270-MNT-V2 AP-270 series outdoor pole/wall short mount kit
JW054A	AP-270-MNT-H1 AP-270 series outdoor hanging or tilt install mount kit
JW055A	AP-270-MNT-H2 AP-270 series flush wall or ceiling mount kit

To remove the pre-assembled bracket and mount the AP-270-MNT-ADP adapter (sold separately), follow these steps:

1. Unscrew the two screws (see [Figure 3](#)) using a Phillips screwdriver.

Figure 3 *Removing the Pre-assembled Bracket*

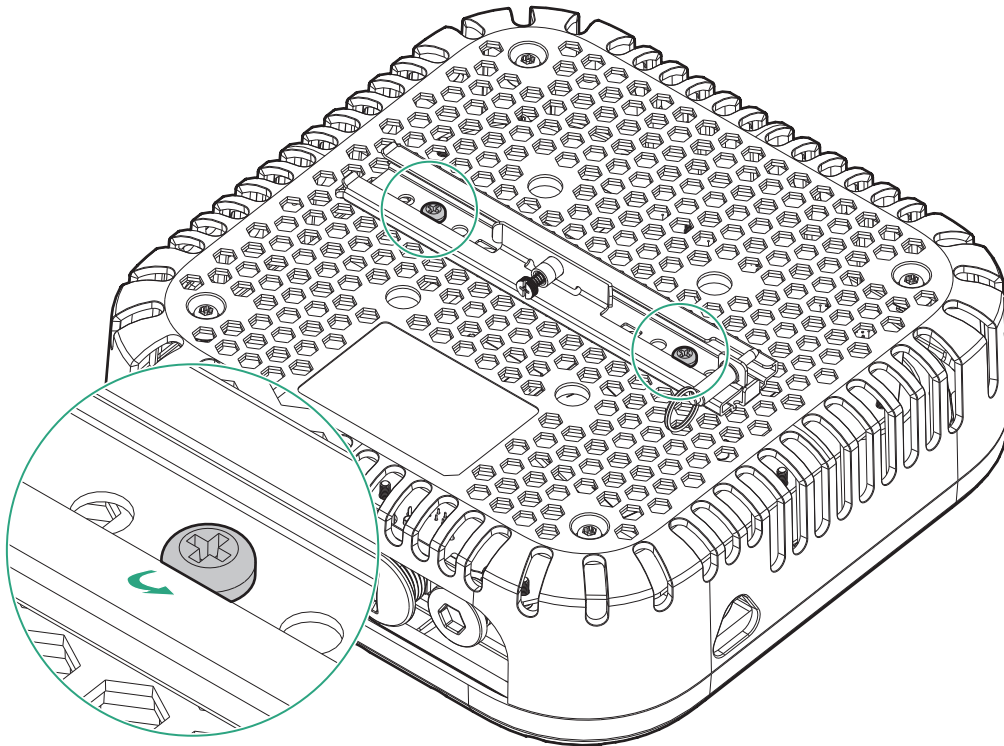
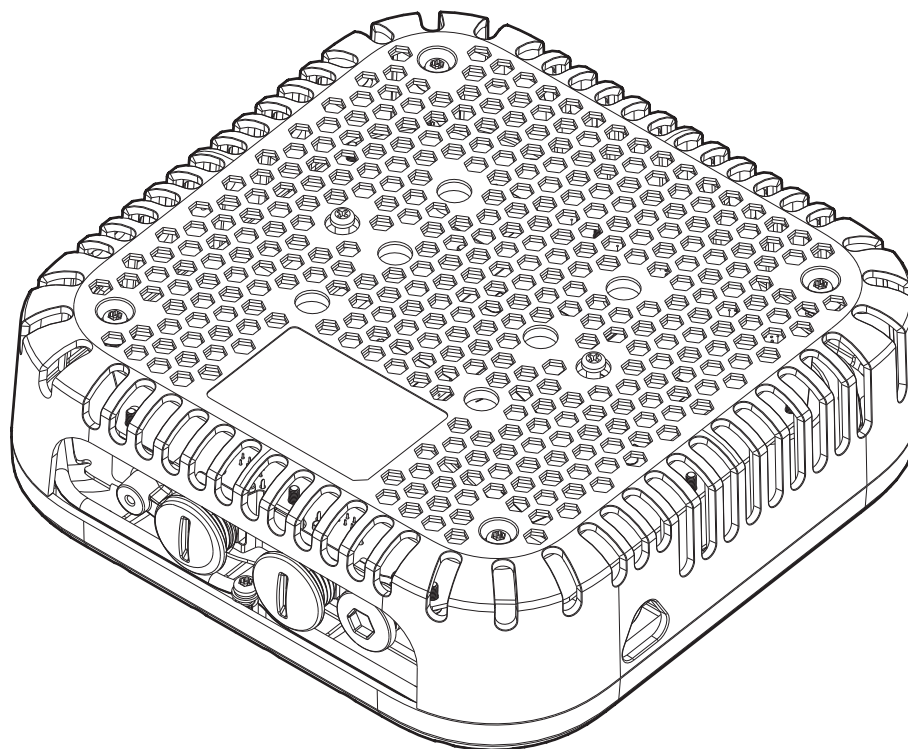

Figure 4 Removing the Pre-assembled Bracket (Completed)



2. Use the M5x12 screws provided with the AP-270-MNT-ADP adapter to attach the AP-270-MNT-ADP adapter to the AP.

Figure 5 Attaching the AP-270-MNT-ADP Adapter to the AP

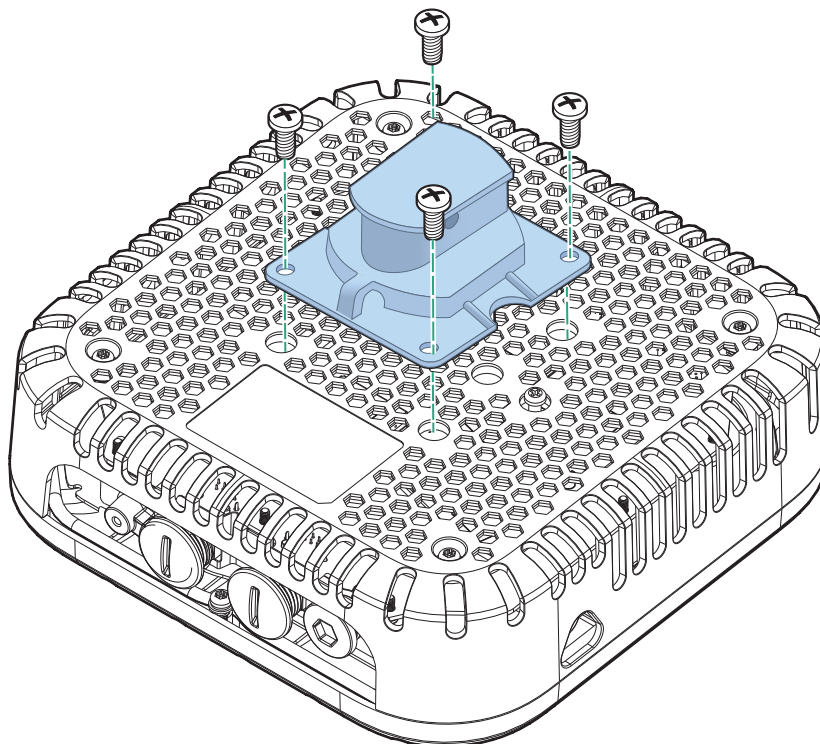
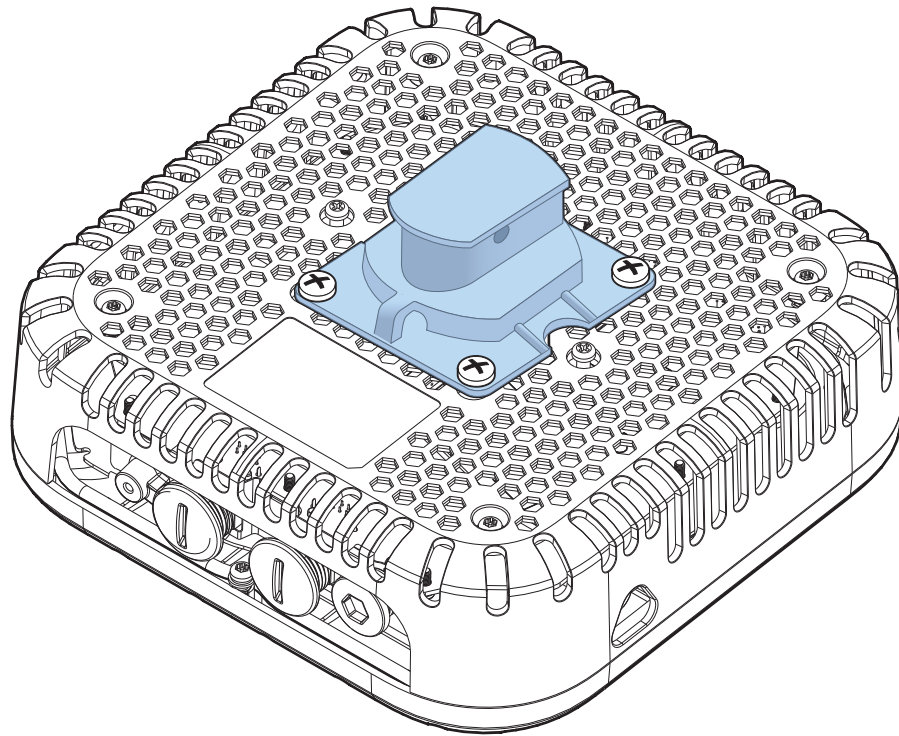

Figure 6 Attaching the AP-270-MNT-ADP Adapter to the AP (Completed)



3. Once the AP-270-MNT-ADP adapter is attached to the AP, the AP can be installed on a wall or attached to a pole using the AP-270-MNT-XX mount kits in [Table 5](#).

Grounding the Access Point

The grounding must be completed before powering up the access point. The grounding wire should be #8 AWG.

1. Peel the cover of one end of the grounding wire and place the bare grounding wire into the included grounding lug, and press firmly with the crimping pliers.
2. Fasten the grounding lug to the grounding hole on the access point with the included M4 x6 screw.

Connecting the Ethernet Cable

To connect the Ethernet cable to the access point, perform the following steps using the Ethernet cable glands that ship with your access point.



CAUTION

Failure to use the included Ethernet cable gland can lead to connectivity and POE issues.



NOTE

The cable is not included and must be purchased separately. Purchase a suitable UV-resistant, outdoor rated, CAT 5E or better RJ45 cable for use with the access point.

Figure 7 *Installing the Ethernet Cable Gland*

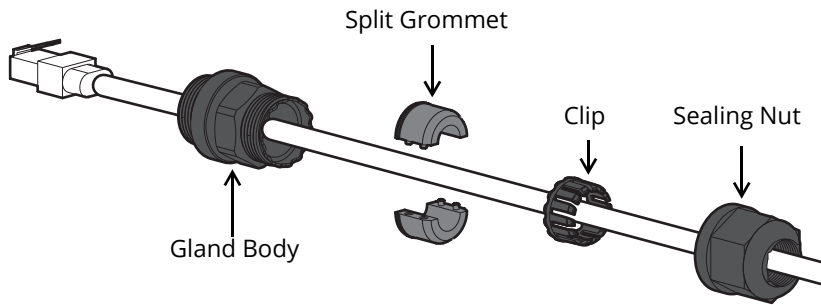

1. Remove the dust cap from the Ethernet port
2. Slide the sealing nut, clip, split grommet and gland body over the cable.
3. Insert the RJ45 connector to the Ethernet port.
4. Screw the gland body onto the Ethernet port.
5. Combine the two split parts of the grommet over the cable, and move it towards the gland body until it locates at the recess of the gland body.
6. Move the clip towards the gland body, passing over the grommet, until the wavy end of the clip properly fits into the wavy end of the gland body.
7. Screw the sealing nut onto the gland body



Two grommets are provided in the package for use with the Ethernet cables. One is applicable for cables with 4-6 mm diameter, and another is applicable for cables with 6-10 mm diameter.

Software

For instructions on choosing operating modes and initial software configuration, refer to the AP Software Quick Start Guide.



Aruba access points are classified as radio transmission devices, and are subject to government regulations of the host country. The network administrator(s) is/are responsible for ensuring that configuration and operation of this equipment is in compliance with their country's regulations. For a complete list of approved channels in your country, refer to the *Aruba Downloadable Regulatory Table* at <https://www.arubanetworks.com/techdocs/DRT/Default.htm>.

Verifying Post-Installation Connectivity

The integrated LEDs on the access point can be used to verify that the access point is receiving power and initializing successfully (see [Table 1](#) and [Table 2](#)). Refer to the **AP Software Quick Start Guide** for further details on verifying post-installation network connectivity.

Electrical and Environmental Specifications

Electrical

- Ethernet
 - E0: 100/1000/2500Base-T auto-sensing Ethernet RJ-45 Interfaces
 - E1: 100/1000Base-T auto-sensing Ethernet RJ-45 Interfaces
 - Power over Ethernet (IEEE 802.3at and 802.3bt compliant)

Environmental

- Operating
 - Temperature: -40°C to 55°C (-40°F to 140°F)

- Storage
 - Temperature: -40°C to 70°C (-40°F to 158°F)
 - Humidity: 5% to 93% non-condensing

For additional specifications on this product, please refer to the data sheet at www.arubanetworks.com.

Regulatory Model Number

For the purpose of regulatory compliance certifications and identification, this product has been assigned a unique regulatory model number (RMN). The regulatory model number can be found on the product nameplate label, along with all required approval markings and information. When requesting compliance information for this product, always refer to this regulatory model number. The regulatory model number RMN is not the marketing name or model number of the product.

The following regulatory model number (RMN) applies to the 518 Series:

- AP-518 RMN: APIN0518

Safety and Regulatory Compliance



RF Radiation Exposure Statement: This equipment complies with RF radiation exposure limits. This equipment should be installed and operated with a minimum distance of 7.87 inches (20 cm) between the radiator and your body for 2.4 GHz and 5 GHz operations. This transmitter must not be co-located or operating in conjunction with any other antenna or transmitter.



Déclaration de la concernant l'exposition aux rayonnements à fréquence radioélectrique (FR): Cet appareil est conforme aux limites d'exposition aux rayonnements FR établies par la FCC. Il doit être installé et utilisé à une distance minimale de 20 cm (7.87 pouces) entre le radiateur et votre corps, qu'il opère sur la bande 2,4 GHz ou 5 GHz. Cet émetteur ne doit pas être installé ou utilisé à proximité immédiate d'une autre antenne ni d'un autre transmetteur.



The device could automatically discontinue transmission in case of absence of information to transmit, or operational failure. Note that this is not intended to prohibit transmission of control or signaling information or the use of repetitive codes where required by the technology.



Changes or modifications to this unit not expressly approved by the party responsible for compliance could void the user's authority to operate this equipment.



Toute modification effectuée sur cet équipement sans l'autorisation expresse de la partie responsable de la conformité est susceptible d'annuler son droit d'utilisation.



Aruba access points must be installed by a professional installer. The professional installer is responsible for ensuring that grounding is available and it meets applicable local and national electrical codes.

United States

This equipment has been tested and found to comply with the limits for a Class B digital device, pursuant to Part 15 of the FCC Rules. These limits are designed to provide reasonable protection against harmful interference in a residential installation. This equipment generates, uses and can radiate radio frequency energy and, if not installed and used in accordance with the manufacturer's instructions, may cause harmful interference to radio communications. However, there is no guarantee that interference will not occur in a particular installation. If this equipment does cause harmful interference to radio or television reception, which can be determined by

turning the equipment off and on, the user is encouraged to try to correct the interference by one or more of the following measures:

- Reorient or relocate the receiving antenna.
- Increase the separation between the equipment and receiver.
- Connect the equipment to an outlet on a circuit different from that to which the receiver is connected.
- Consult the dealer or an experienced radio or TV technician for help.

Improper termination of access points installed in the United States configured to a non-US model controller is a violation of the FCC grant of equipment authorization. Any such willful or intentional violation may result in a requirement by the FCC for immediate termination of operation and may be subject to forfeiture (47 CFR 1.80).

Industry Canada

This Class B digital apparatus meets all of the requirements of the Canadian Interference-Causing Equipment Regulations.

In accordance with Industry Canada regulations, this radio transmitter and receiver may only be used with an antenna, the maximum type and gain of which must be approved by Industry Canada. To reduce potential radio interference, the type of antenna and its gain shall be chosen so that the equivalent isotropic radiated power (EIRP) does not exceed the values necessary for effective communication.

This device complies with Industry Canada's license-exempt RSS regulations. Operation of this device is subject to the following two conditions: (1) this device may not cause interference, and (2) this device must accept any interference, including interference that may cause undesired operation.

When operated in 5.15 to 5.25 GHz frequency range, this device is restricted to indoor use to reduce the potential for harmful interference with co-channel Mobile Satellite Systems.

This radio transmitter model APIN0518 has been approved by Industry Canada to operate with the antenna types listed in the online ordering guide (link provided below) with the maximum permissible gain indicated. Antenna types not included in this list, having a greater gain than the maximum gain indicated for that type, are strictly prohibited for use with this device.

http://www.arubanetworks.com/assets/og/OG_AP-518Series.pdf

Déclaration d'Industrie Canada

Ce périphérique est conforme aux règlements RSS exempts de licence d'Industrie Canada. L'utilisation de ce périphérique est soumise aux deux conditions suivantes : (1) ce périphérique ne doit pas provoquer d'interférences, et (2) ce périphérique doit accepter toute interférence, y compris les interférences susceptibles de provoquer un dysfonctionnement.

En cas d'utilisation dans la plage de fréquences de 5,15 à 5,25 GHz, cet appareil doit uniquement être utilisé en intérieur afin de réduire les risques d'interférence avec les systèmes satellites mobiles partageant le même canal.

Ce modèle d'émetteur radio APIN0518 a été approuvé par Industrie Canada pour fonctionner avec les types d'antenne énumérés dans le guide de commande en ligne (lien ci-dessous) avec le gain maximal admissible indiqué. Les types d'antennes non inclus dans cette liste, ayant un gain supérieur au gain maximal indiqué pour ce type, sont strictement interdits pour une utilisation avec cet appareil.

http://www.arubanetworks.com/assets/og/OG_AP-518Series.pdf

European Union Regulatory Conformance

The Declaration of Conformity made under Radio Equipment Directive 2014/53/EU is available for viewing at: www.hpe.com/eu/certificates. Select the document that corresponds to your device's model number as it is indicated on the product label.

This radio transmitter model has been approved to operate with the antenna types listed in the online ordering guide (link provided below) with the maximum permissible gain indicated. Antenna types not included in this list, having a greater gain than the maximum gain indicated for the type, are strictly prohibited for use with this device. Compliance is only assured if the Aruba approved accessories as listed in the ordering guide are used.

http://www.arubanetworks.com/assets/og/OG_AP-518Series.pdf

Wireless Channel Restrictions

5150-5350MHz band is limited to indoor only in the following countries; Austria (AT), Belgium (BE), Bulgaria (BG), Croatia (HR), Cyprus (CY), Czech Republic (CZ), Denmark (DK), Estonia (EE), Finland (FI), France (FR), Germany (DE), Greece (GR), Hungary (HU), Iceland (IS), Ireland (IE), Italy (IT), Latvia (LV), Liechtenstein (LI), Lithuania (LT), Luxembourg (LU), Malta (MT), Netherlands (NL), Norway (NO), Poland (PL), Portugal (PT), Romania (RO), Slovakia (SK), Slovenia (SL), Spain (ES), Sweden (SE), Switzerland (CH), Turkey (TR), United Kingdom (UK).

Radio	Frequency Range MHz	Max EIRP
BLE/Zigbee	2402-2480	9 dBm
Wi-Fi	2412-2472	20 dBm
	5150-5250	23 dBm
	5250-5350	23 dBm
	5470-5725	30 dBm
	5725-5850	N/A for EU



Lower power radio LAN product operating in 2.4 GHz and 5 GHz bands. Please refer to the ArubaOS User Guide/ Instant User Guide for details on restrictions.

Medical

1. Equipment not suitable for use in the presence of flammable mixtures.
2. Connect to only IEC 60950-1 or IEC 60601-1 certified products and power sources. The end user is responsible for the resulting medical system complies with the requirements of IEC 60601-1.
3. Wipe with a dry cloth, no additional maintenance required.
4. No serviceable parts, the unit must be sent back to the manufacturer for repair.
5. No modifications are allowed without Aruba approval.

Taiwan

第十二條

經型式認證合格之低功率射頻電機，非經許可，公司，商號或使用者均不得擅自變更頻率、加大功率或變更原設計之特性及功能。

第十四條

低功率射頻電機之使用不得影響飛航安全及干擾合法通信；經發現有干擾現象時，應立即停用，並改善至無干擾時方得繼續使用。前項合法通信，指依電信法規定作業之無線電通信。低功率射頻電機須忍受合法通信或工業、科學及醫療用電波輻射性電機設備之干擾。

1. 應避免影響附近雷達系統之操作。
2. 高增益指向性天線只得應用於固定式點對點系統
3. 電磁波暴露量 MPE 標準值 1 mW/cm²，送測產品實測值為：0.997mW/cm²

Brazil

Este equipamento não tem direito à proteção contra interferência prejudicial e não pode causar interferência em sistemas devidamente autorizados.

Japan

ご使用になっている装置に VCCI マークが付いていましたら、次の説明文をお読み下さい。

この装置は、クラス B 情報技術装置です。この装置は、家庭環境で使用することを目的としていますが、この装置がラジオやテレビジョン受信機に近接して使用されると、受信障害を引き起こすことがあります。取扱説明書に従って正しい取り扱いをして下さい。

VCCI-B

México

La operación de este equipo está sujeta a las siguientes dos condiciones: (1) es posible que este equipo o dispositivo no cause interferencia perjudicial y (2) este equipo o dispositivo debe aceptar cualquier interferencia, incluyendo la que pueda causar su operación no deseada.

Нормативные требования Евразийского Экономического Союза



HPE Russia: ООО "Хьюлетт Паккард Энтерпрайз" Российская Федерация, 125171, г. Москва, Ленинградское шоссе, 16А, стр.3, Телефон: +7 499 403 4248 Факс: +7 499 403 4677

'HPE Kazakhstan': ТОО «Хьюлетт-Паккард (К)», Республика Казахстан, 050040, г. Алматы, Бостандыкский район, проспект Аль-Фараби, 77/7, Телефон/факс: + 7 727 355 35 50

Kazakhstan

ЖШС "Хьюлетт Паккард Энтерпрайз" Ресей Федерациясы, 125171, Мәскеу, Ленинград тас жолы, 16А блок 3, Телефон: +7 499 403 4248 Факс: +7 499 403 4677

ЖШС «Хьюлетт-Паккард (К)», Қазақстан Республикасы, 050040, Алматы қ., Бостандық ауданы, Әл-Фараби даңғылы, 77/7, Телефон/факс: +7 (727) 355 35 50

Ukraine

Hereby, Hewlett Packard Enterprise Company declares that the radio equipment type [The Regulatory Model Number [RMN] for this device can be found in the [Regulatory Model Number](#) section of this document] is in compliance with Ukrainian Technical Regulation on Radio Equipment, approved by resolution of the CABINET OF MINISTERS OF UKRAINE dated May 24, 2017, No. 355. The full text of the UA declaration of conformity is available at the following internet address: <https://certificates.ext.hpe.com/public/certificates.html>

Х'ЮЛЕТТ ПАКАРД ЭНТЕРПРАЗ, 6280 АМЕРИКА ЦЕНТР Д-Р, САН-ХОСЕ, КАЛИФОРНИЯ 95002, США

Contact Aruba

Main Site	https://www.arubanetworks.com
Support Site	https://asp.arubanetworks.com
Airheads Social Forums and Knowledge Base	https://community.arubanetworks.com/
North America Telephone	1-800-943-4526 1-408-754-1200
International Telephone	https://www.arubanetworks.com/support-services/contact-support/
Software Licensing Site	https://www.hpe.com/networking/support
End-of-Life Information	https://www.arubanetworks.com/support-services/end-of-life/
Security Incident Response Team (SIRT)	https://www.arubanetworks.com/support-service/security-bulletins/ Email: aruba-sirt@hpe.com

Copyright

© Copyright 2020 Hewlett Packard Enterprise Development LP

Open Source Code

This product includes code licensed under the GNU General Public License, the GNU Lesser General Public License, and/or certain other open source licenses.

A complete machine-readable copy of the source code corresponding to such code is available upon request. This offer is valid to anyone in receipt of this information and shall expire three years following the date of the final distribution of this product version by Hewlett Packard Enterprise Company.

To obtain such source code, send a check or money order in the amount of US \$10.00 to:

Hewlett Packard Enterprise Company

Attn: General Counsel

6280 America Center Drive

San Jose, CA 94089

USA

Warranty

This hardware product is protected by an Aruba warranty. For more details, visit www.hpe.com/us/en/support.html