

# Aruba 500 Series Campus Access Points

## Installation Guide

The Aruba 500 Series campus access points (AP-504 and AP-505) are high-performance, dual-radio wireless devices that can be deployed in either controller-based (ArubaOS) or controllerless (Aruba Instant) network environments. These access points deliver high performance concurrent 2.4 GHz and 5 GHz 802.11ax Wi-Fi functionality with MIMO radios (2x2 in 2.4 GHz, 4x4 in 5 GHz), while also supporting legacy 802.11a/b/g/n/ac wireless services.

In addition to both Wi-Fi radios, these APs also incorporate a Bluetooth Low Energy (BLE) and Zigbee radio, supporting a variety of use-cases and services, such as locationing and IoT.

A mount kit (sold separately) is needed to mount the AP. Make sure to purchase the correct mount kit for the intended deployment of the AP.

## Package Contents

- Aruba 500 Series access point (with a pre-installed mount bracket)



---

The AP mount bracket attaches to a variety of mount kits (sold separately).

---



---

Inform your supplier if there are any incorrect, missing, or damaged parts. If possible, retain the carton, including the original packing materials. Use these materials to repack and return the unit to the supplier if needed.

---

## Hardware Overview

The following sections outline the hardware components of the 500 Series access points.

**Figure 1** AP-505 Front View

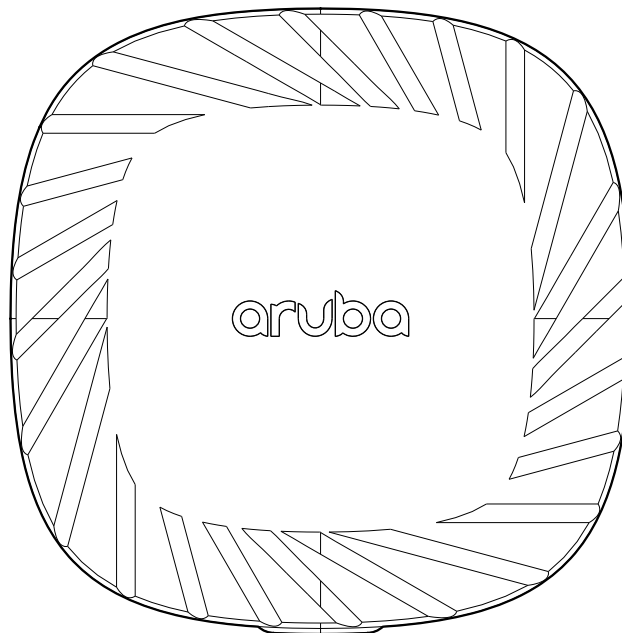

**Figure 2** AP-504 Front View

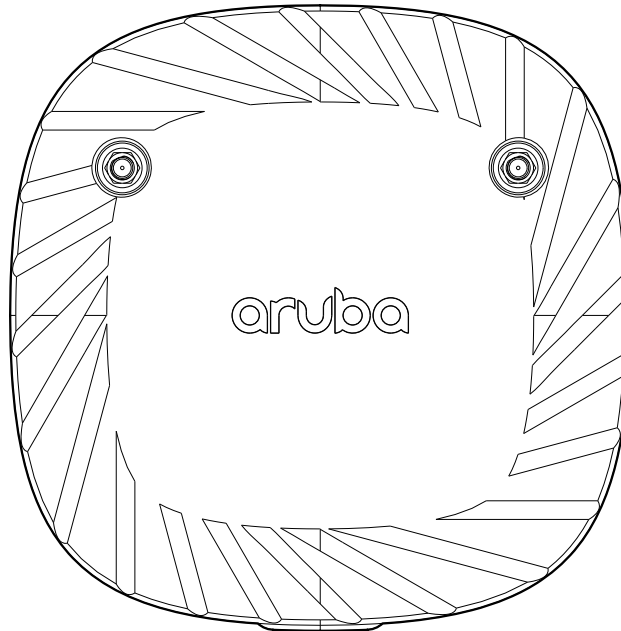

## External Antenna Connectors

The AP-504 access points are equipped with two external antenna connectors located on the front corners of the access point (see [Figure 2](#)). Antenna ports A0 and A1 (corresponding with radio chain 0 and 1), are used for both radios and bands (RF signals are diplexed).

---

External antennas for this device must be installed by an Aruba Certified Mobility Professional (ACMP) or other Aruba-certified technician, using manufacturer-approved antennas only.

The Equivalent Isotropically Radiated Power (EIRP) levels for all external antenna devices must not exceed the regulatory limit set by the host country/domain.

Installers are required to record the antenna gain for this device in the system management software. A list of approved antennas can be found at: [http://www.arubanetworks.com/assets/og/OG\\_AP-500Series.pdf](http://www.arubanetworks.com/assets/og/OG_AP-500Series.pdf).

---



**CAUTION**

---

Les antennes externes pour cet appareil doivent être installées par un professionnel de la mobilité certifié Aruba (ACMP) ou un autre technicien certifié Aruba, en utilisant uniquement des antennes approuvées par le fabricant. Les niveaux équivalents de puissance à rayonnement isotrope (EIRP) pour tous les périphériques d'antenne externe ne doivent pas dépasser la limite réglementaire définie par le pays hôte / domaine.

Les installateurs doivent enregistrer le gain d'antenne pour cet appareil dans le logiciel de gestion du système. Une liste d'antennes approuvées peut être trouvée à [http://www.arubanetworks.com/assets/og/OG\\_AP-500Series.pdf](http://www.arubanetworks.com/assets/og/OG_AP-500Series.pdf).

---

**Figure 3** LEDs (AP-505 shown)

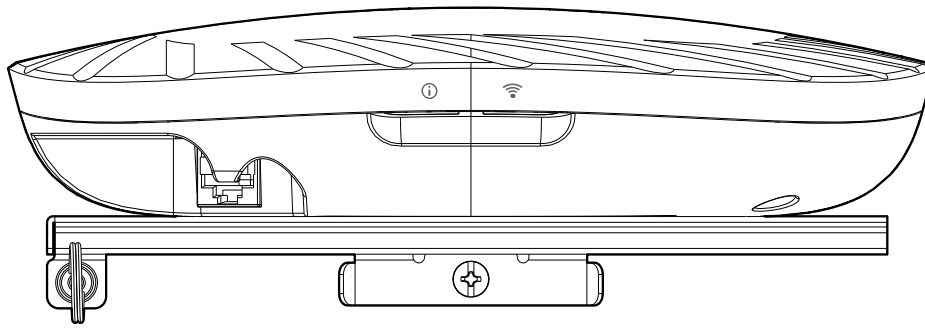

## LEDs

### System Status

The System Status LED indicates the operating condition of the access point.

**Table 1** System Status LED ⓘ

Color/State	Meaning
Off	Device Powered off
Green- solid	Device ready, fully functional, no network restrictions
Green- blinking <sup>1</sup>	Device booting, not ready
Green- flashing off <sup>2</sup>	Device ready, fully functional, uplink negotiated in sub-optimal speed (<1Gbps)
Green- flashing on <sup>3</sup>	Device in deep-sleep mode
Amber- solid	Device ready, restricted power mode (IPM restrictions applied), no network restrictions
Amber- flashing off	Device ready, restricted power mode (IPM restrictions applied), uplink negotiated in sub-optimal speed (<1Gbps)
Red	System error condition - Immediate action required

1. Blinking: one second on, one second off, 2 seconds cycle.

2. Flashing off: mostly on, fraction of a second off, 2 seconds cycle.

3. Flashing on: mostly off, fraction of a second on, 2 seconds cycle.

### Radio Status

The Radio Status LED indicates the operating mode of the access point's radios.

**Table 2** Radio Status LEDs ⓘ

Color/State	Meaning
Off	Device powered off, or both radios disabled
Green- solid	Both radios enabled in access mode
Green- blinking	One radio enabled in access mode, other disabled
Amber- solid	Both radios enabled in monitor mode

Color/State	Meaning
Amber- blinking	One radio enabled in monitor mode, other disabled
Green/Amber- alternating <sup>1</sup>	Green: one radio in access mode Amber: one radio in monitor mode

1. Alternating: one second each color, 2 seconds cycle.

## LED Display Settings

The LEDs have three operating modes that can be selected in the system management software:

- Normal mode: Refer to [Table 1](#) and [Table 2](#)
- Off mode: LEDs are off
- Blink mode: LEDs blink green (synchronized)

**Figure 4** AP-505 Rear View

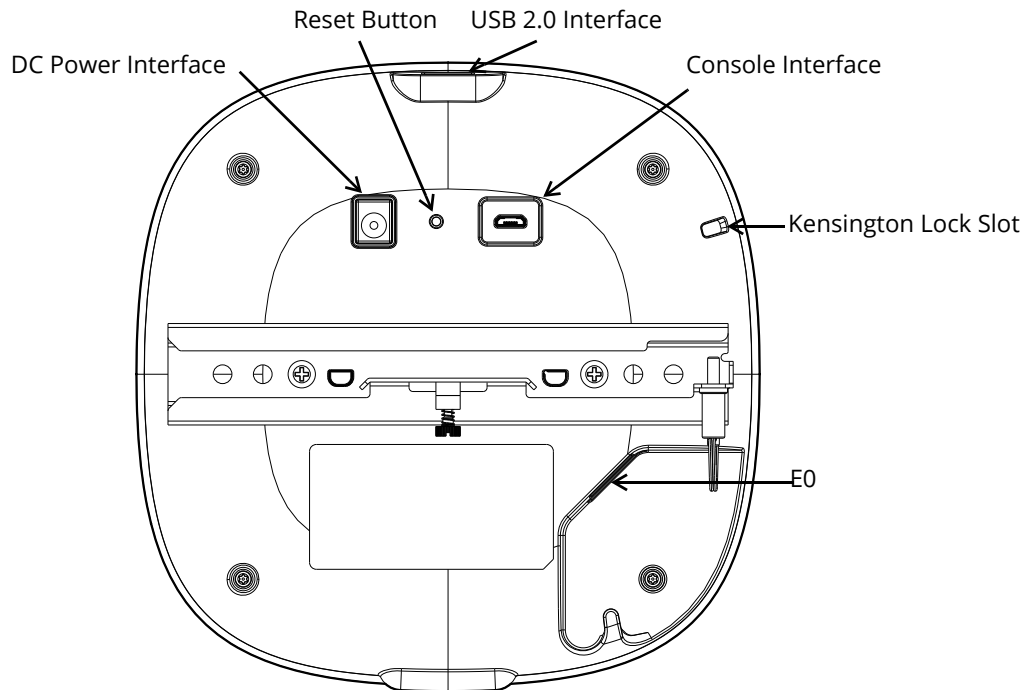

## Cable Guide

The cable guide on the rear of the access point is used to organize cables, as shown in [Figure 5](#). The use of the cable guide is optional and does not support all types of cables and plugs.

**Figure 5** Cable Guide

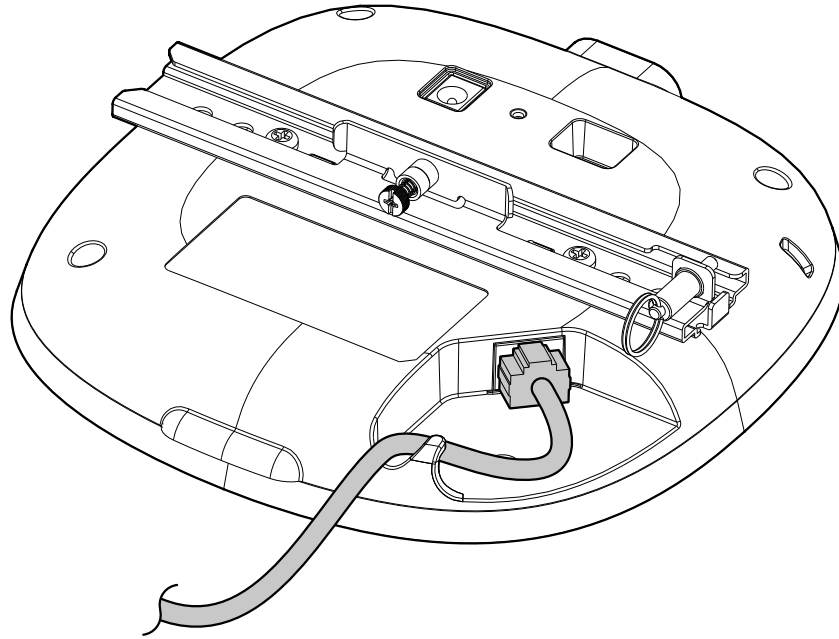

## Bluetooth Low Energy and Zigbee Radio

500 Series access points are equipped with an integrated BLE and Zigbee radio that provide the following capabilities:

- location beacon applications
- wireless console access
- IOT gateway applications

## Console Port

The console port is a Micro-B connector located on the back of this device. A proprietary serial adapter cable (AP-CBL-SERU) is needed to use this interface. It is sold separately to connect the AP to a serial terminal or a laptop for direct local management (a standard USB cable cannot be used for this interface).

## Ethernet Port

The Aruba 500 Series is equipped with a 10/100/1000Base-T auto-sensing MDI/MDX Ethernet port (E0). This E0 port supports IEEE 802.3af and 802.3at Power over Ethernet compliance, accepting power from a Power Sourcing Equipment (PSE) such as a PoE midspan injector, or network infrastructure that support PoE.

## Kensington Lock Slot

The 500 Series is equipped with a Kensington lock slot for additional physical security.

## USB 2.0 Interface

The top of this access point is equipped with a USB-A port that is compatible with selected cellular modems and other peripherals. When active, this port can supply up to 5W/1A to a connected device.

## Reset Button

The reset button located on the back of the device can be used to reset the access point to factory default settings or turn off/on the LED display.

There are two ways to reset the access point to factory default settings:

### Reset the AP during normal operation

press and hold down the reset button using a small, narrow object such as a paper clip for more than 10

seconds during normal operation.

## Reset the AP while powering up

1. Press and hold down the reset button using a small, narrow object such as a paper clip while the access point is not powered on (either via DC power or PoE).
2. Connect the power supply (DC or PoE) to the access point while the reset button is being held down.
3. Release the reset button on the access point after 15 seconds.

To turn off/on the LED display, press and release the reset button using a small, narrow object, such as a paperclip for less than 10 seconds during normal operation of the access point.

## Power

E0 port supports PoE-in (AP is a PoE-PD device), allowing the device to draw power from compliant PoE power sources. If PoE is not available, a proprietary AP-AC-12V30B power adapter (sold separately) can be used to power the access point. When both PoE and DC power sources are available, the DC power source takes precedence. In that case, the access point simultaneously draws a minimal current from the PoE source. In the event that the DC source fails, the access point switches to the PoE sources.

The Intelligent Power Monitoring (IPM) feature may also be used to manage the power consumption preferences for this device. When enabled, the user may enable/disable power restrictions for the access point using Aruba's AP management software.

Table 3 lists operational restrictions when the access point is powered by different power options.

**Table 3** Power Options and Operational Restrictions

Power Source	IPM	Restrictions
DC power	n/a	No restrictions, all capabilities available
PoE 802.3at	n/a	No restrictions, all capabilities available
PoE 802.3af	enabled	All capabilities available (features may be disabled per IPM configuration)
PoE 802.3af	disabled	USB disabled

The 500 Series access points support a deep-sleep mode to deliver significant power and cost savings.

## Before You Begin

Refer to the sections below before beginning the installation process.



**FCC Statement:** Improper termination of access points installed in the United States configured to non-US model controllers will be in violation of the FCC grant of equipment authorization. Any such willful or intentional violation may result in a requirement by the FCC for immediate termination of operation and may be subject to forfeiture (47 CFR 1.80).

## Pre-Installation Checklist

Before installing your Aruba 500 Series access point, be sure that you have the following (not included with the AP):

- A mount kit compatible with the AP and mount surface
- Cat5E or better UTP cable with network access
- One or more external antennas (when using the AP-504)
- (Optional) a compatible 12V AC-to-DC power adapter with power cord
- (Optional) a compatible PoE midspan injector with power cord
- (Optional) a compatible snap-on front cover (for easy aesthetic customization)
- (Optional) an AP-CBL-SERU console cable

Also make sure that (at least) one of the following network services is supported:

- Aruba Discovery Protocol (ADP)
- DNS server with an "A" record
- DHCP Server with vendor-specific options



---

The Aruba 500 Series access point is designed in compliance with governmental requirements so that only authorized network administrators can change the settings. For more information about access point configuration, refer to the *AP Software Quick Start Guide*.

---

## Identifying Specific Installation Locations

Use the access point placement map generated by Aruba RF Plan software application to determine the proper installation location(s). Each location should be as close as possible to the center of the intended coverage area and should be free from obstructions or obvious sources of interference. These RF absorbers/reflectors/interference sources will impact RF propagation and should be accounted for during the planning phase and adjusted for in RF plan.



---

Use of this equipment adjacent to or stacked with other equipment should be avoided because it could result in improper operation. If such use is necessary, this equipment and the other equipment should be observed to verify that they are operating normally.

---

## Identifying Known RF Absorbers/Reflectors/Interference Sources

Identifying known RF absorbers, reflectors, and interference sources while in the field during the installation phase is critical. Make sure that these sources are taken into consideration when you attach an access point to its fixed location.

RF absorbers include:

- Cement/concrete—Old concrete has high levels of water dissipation, which dries out the concrete, allowing for potential RF propagation. New concrete has high levels of water concentration in the concrete, blocking RF signals.
- Natural Items—Fish tanks, water fountains, ponds, and trees
- Brick

RF reflectors include:

- Metal Objects—Metal pans between floors, rebar, fire doors, air conditioning/heating ducts, mesh windows, blinds, chain link fences (depending on aperture size), refrigerators, racks, shelves, and filing cabinets.
- Do not place an access point between two air conditioning/heating ducts. Make sure that access points are placed below ducts to avoid RF disturbances.

RF interference sources include:

- Microwave ovens and other 2.4 or 5 GHz objects (such as cordless phones)
- Cordless headset such as those used in call centers or lunch rooms



---

Portable RF communications equipment (including peripherals such as antenna cables and external antennas) should be used no closer than 30 cm (12 inches) to any part of the access point. Otherwise, degradation of the performance of this equipment could result.

---

---

RF Radiation Exposure Statement: This equipment complies with FCC RF radiation exposure limits. This equipment should be installed and operated with a minimum distance of 20 cm between the radiator and your body for 2.4 GHz and 5 GHz operations. This transmitter must not be co-located or operating in conjunction with any other antenna or transmitter.

---



---

Déclaration sur les limites d'exposition aux radiofréquences : cet équipement est conforme aux limites d'exposition aux rayonnements radioélectriques spécifiées par la FCC. Il doit être installé et utilisé à une distance minimale de 20 cm par rapport à votre corps pour les fréquences de 2,4 et 5 GHz. Cet émetteur-récepteur ne doit pas être utilisé ou situé à proximité d'autres antennes ou émetteurs-récepteurs.

---

## Access Point Installation

the Aruba 500 Series access points are designed for ceiling or wall mounted deployments. Several optional

mount kits are available to attach the Aruba 500 Series access point to a variety of surfaces. These mount kits are available as accessories and must be ordered separately. Refer to the online ordering guide at [http://www.arubanetworks.com/assets/og/OG\\_AP-500Series.pdf](http://www.arubanetworks.com/assets/og/OG_AP-500Series.pdf)

All Aruba access points should be professionally installed by an Aruba-Certified Mobility Professional (ACMP). The installer is responsible for ensuring that grounding is available and meets applicable national and electrical codes. Failure to properly install this product may result in physical injury and/or damage to property.



Tous les points d'accès Aruba doivent impérativement être installés par un professionnel agréé. Ce dernier doit s'assurer que l'appareil est mis à la terre et que le circuit de mise à la terre est conforme aux codes électriques nationaux en vigueur. Le fait de ne pas installer correctement ce produit peut entraîner des blessures corporelles et / ou des dommages matériels.



The installer is responsible for securing the access point onto the ceiling tile rail. Failure to properly install this product may result in physical injury and/or damage to property.



Use of accessories, transducers and cables other than those specified or provided by the manufacturer of this equipment could result in increased electromagnetic emissions or decreased electromagnetic immunity of this equipment and result in improper operation.

## Software

For instructions on choosing operating modes and initial software configuration, refer to the AP Software Quick Start Guide.



Aruba access points are classified as radio transmission devices, and are subject to government regulations of the host country. The network administrator(s) is/are responsible for ensuring that configuration and operation of this equipment is in compliance with their country's regulations. For a complete list of approved channels in your country, refer to the *Aruba Downloadable Regulatory Table* at [support.arubanetworks.com](http://support.arubanetworks.com).

## Verifying Post-Installation Connectivity

The integrated LED on the access point can be used to verify that the access point access point is receiving power and initializing successfully (see [Table 1-Table 2](#)). Refer to the **AP Software Quick Start Guide** for further details on verifying post-installation network connectivity.

## Electrical and Environmental Specifications

For additional specifications on this product, please refer to the product data sheet at [www.arubanetworks.com](http://www.arubanetworks.com)

### Electrical

- Ethernet:
  - E0 port: 10/100/1000BaseT auto-sensing MDI/MDX wired RJ45 network connectivity port
- Power:
  - 12V DC power interface, support powering through AC-to-DC power adapter (AP-AC-12V30B)
  - Power over Ethernet (PoE): 802.3af or 802.3at compliant source



If a power adapter other than the Aruba-approved adapter is used in the US or Canada, it should be NRTL listed, with an output rated 12V DC, minimum 0.75A, marked "LPS" and "Class 2," and suitable for plugging into a standard power receptacle in the US and Canada.

### Environmental

- Operating:



- Temperature: 0°C to +50°C (+32°F to +122°F)
- Humidity: 5% to 93% non-condensing
- Storage and transport:
  - Temperature: -40°C to +70°C (-40°F to +158°F)
  - Humidity: 5% to 93% non-condensing



---

The Aruba 500 Series access points are for indoor use only. The access point, AC adapter, and all connected cables are not designed for outdoor use.

---



---

This device is intended for stationary use in partly temperature controlled weather-protected environments.

---

## Regulatory Model Name

The following regulatory model numbers (RMN) apply to the 500 Series:

- AP-504 RMN: APIN0504
- AP-505 RMN: APIN0505

## Safety and Regulatory Compliance



---

**RF Radiation Exposure Statement:** This equipment complies with RF radiation exposure limits. This equipment should be installed and operated with a minimum distance of 20 cm between the radiator and your body for 2.4 GHz and 5 GHz operations. This transmitter must not be co-located or operating in conjunction with any other antenna or transmitter.

---



---

**Déclaration de la concernant l'exposition aux rayonnements à fréquence radioélectrique (FR):** Cet appareil est conforme aux limites d'exposition aux rayonnements FR établies. Il doit être installé et utilisé à une distance minimale de 20 cm entre le radiateur et votre corps, qu'il opère sur la bande 2,4 GHz ou 5 GHz. Cet émetteur ne doit pas être installé ou utilisé à proximité immédiate d'une autre antenne ni d'un autre transmetteur.

---



---

Changes or modifications to this unit not expressly approved by the party responsible for compliance could void the user's authority to operate this equipment.

---



---

Toute modification effectuée sur cet équipement sans l'autorisation expresse de la partie responsable de la conformité est susceptible d'annuler son droit d'utilisation.

---

## Federal Communication Commission

This device complies with Part 15 of the FCC Rules. Operation is subject to the following two conditions: (1) this device may not cause harmful interference, and (2) this device must accept any interference received, including interference that may cause undesired operation.

This equipment has been tested and found to comply with the limits for a Class B digital device, pursuant to Part 15 of the FCC Rules. These limits are designed to provide reasonable protection against harmful interference in a residential installation. This equipment generates, uses and can radiate radio frequency energy and, if not installed and used in accordance with the manufacturer's instructions, may cause harmful interference to radio communications. However, there is no guarantee that interference will not occur in a particular installation. If this equipment does cause harmful interference to radio or television reception, which can be determined by turning the equipment off and on, the user is encouraged to try to correct the interference by one or more of the following measures:

- Reorient or relocate the receiving antenna.
- Increase the separation between the equipment and receiver.

- Connect the equipment to an outlet on a circuit different from that to which the receiver is connected.
- Consult the dealer or an experienced radio or TV technician for help.

## Industry Canada

This Class B digital apparatus meets all of the requirements of the Canadian Interference-Causing Equipment Regulations.

In accordance with Industry Canada regulations, this radio transmitter and receiver may only be used with an antenna, the maximum type and gain of which must be approved by Industry Canada. To reduce potential radio interference, the type of antenna and its gain shall be chosen so that the equivalent isotropic radiated power (EIRP) does not exceed the values necessary for effective communication.

This device complies with Industry Canada's license-exempt RSS regulations. Operation of this device is subject to the following two conditions: (1) this device may not cause interference, and (2) this device must accept any interference, including interference that may cause undesired operation.

When operated in the 5.15 to 5.25 GHz frequency range, this device is restricted to indoor use to reduce the potential for harmful interference with co-channel Mobile Satellite Systems.

## Déclaration d'Industrie Canada

Conformément aux réglementations d'Industrie Canada, cet émetteur-récepteur radio doit être utilisé uniquement avec une antenne dont le type et le gain maximal doivent être approuvés par Industrie Canada. Pour réduire les interférences radio potentielles, le type d'antenne et son gain doivent être choisis de façon à ce que la puissance isotrope rayonnée équivalente (PIRE) ne dépasse pas les valeurs nécessaires à une communication efficace.

Ce périphérique est conforme aux règlements RSS exempts de licence d'Industrie Canada. L'utilisation de ce périphérique est soumise aux deux conditions suivantes : (1) ce périphérique ne doit pas provoquer d'interférences, et (2) ce périphérique doit accepter toute interférence, y compris les interférences susceptibles de provoquer un dysfonctionnement.

En cas d'utilisation dans la plage de fréquences de 5,15 à 5,25 GHz, cet appareil doit uniquement être utilisé en intérieur afin de réduire les risques d'interférence avec les systèmes satellites mobiles partageant le même canal.

## Canadian Caution

This radio transmitter model APIN0504/APIN0505 has been approved by Industry Canada to operate with the antenna types listed in the table in the online ordering guide (link provided below) with the maximum permissible gain indicated. Antenna types not included in this list, having a gain greater than the maximum gain indicated for that type, are strictly prohibited for use with this device.

[http://www.arubanetworks.com/assets/og/OG\\_AP-500Series.pdf](http://www.arubanetworks.com/assets/og/OG_AP-500Series.pdf)

Le présent transmetteur radio modèle APIN0504/APIN0505 a été approuvé par Industrie Canada pour fonctionner avec les types d'antennes indiqués dans le tableau du guide de commande en ligne (lien fourni ci-dessous) avec le gain permissible maximum indiqué. Il est strictement défendu d'utiliser avec cet appareil les types d'antennes non inclus dans cette liste, ayant un gain supérieur au gain maximum indiqué pour ce type.

[http://www.arubanetworks.com/assets/og/OG\\_AP-500Series.pdf](http://www.arubanetworks.com/assets/og/OG_AP-500Series.pdf)

## European Union Regulatory Conformance

The Declaration of Conformity made under Radio Equipment Directive 2014/53/EU is available for viewing at: [www.hpe.com/eu/certificates](http://www.hpe.com/eu/certificates). Select the document that corresponds to your device's model number as it is indicated on the product label

This radio transmitter model has been approved to operate with the antenna types listed in the online ordering guide (link provided below) with the maximum permissible gain indicated. Antenna types not included in this list, having a greater gain than the maximum gain indicated for the type, are strictly prohibited for use with this device. Compliance is only assured if the Aruba approved accessories as listed in the ordering guide are used.

[http://www.arubanetworks.com/assets/og/OG\\_AP-500Series.pdf](http://www.arubanetworks.com/assets/og/OG_AP-500Series.pdf)

## Wireless Channel Restrictions

5150-5350MHz band is limited to indoor only in the following countries; Austria (AT), Belgium (BE), Bulgaria (BG), Croatia (HR), Cyprus (CY), Czech Republic (CZ), Denmark (DK), Estonia (EE), Finland (FI), France (FR), Germany (DE), Greece (GR), Hungary (HU), Iceland (IS), Ireland (IE), Italy (IT), Latvia (LV), Liechtenstein (LI), Lithuania (LT), Luxembourg (LU), Malta (MT), Netherlands (NL), Norway (NO), Poland (PL), Portugal (PT), Romania (RO), Slovakia

(SK), Slovenia (SL), Spain (ES), Sweden (SE), Switzerland (CH), Turkey (TR), United Kingdom (UK).

Radio	Frequency Range MHz	Max EIRP
BLE/Zigbee	2402-2480	9 dBm
Wi-Fi	2412-2472	20 dBm
	5150-5250	23 dBm
	5250-5350	23 dBm
	5470-5725	30 dBm
	5725-5850	14 dBm



CAUTION

Lower power radio LAN product operating in 2.4 GHz and 5 GHz bands. Please refer to the ArubaOS User Guide/ Instant User Guide for details on restrictions.

## Medical

1. Equipment not suitable for use in the presence of flammable mixtures.
2. Connect to only IEC 60950-1 or IEC 60601-1 certified products and power sources. The end user is responsible for the resulting medical system complies with the requirements of IEC 60601-1.
3. Wipe with a dry cloth, no additional maintenance required.
4. No serviceable parts, the unit must be sent back to the manufacturer for repair.
5. No modifications are allowed without Aruba approval.



NOTE

This device is intended for indoor use in professional healthcare facilities.



NOTE

This device has no IEC/EN60601-1-2 essential performance.



CAUTION

Use of this equipment adjacent to or stacked with other equipment should be avoided because it could result in improper operation. If such use is necessary, this equipment and the other equipment should be observed to verify that they are operating normally.



NOTE

Compliance is based on the use of Aruba approved accessories. Refer to the ordering guide for this access point at [http://www.arubanetworks.com/assets/og/OG\\_AP-500Series.pdf](http://www.arubanetworks.com/assets/og/OG_AP-500Series.pdf).



CAUTION

Use of accessories, transducers and cables other than those specified or provided by the manufacturer of this equipment could result in increased electromagnetic emissions or decreased electromagnetic immunity of this equipment and result in improper operation.



CAUTION

Portable RF communications equipment (including peripherals such as antenna cables and external antennas) should be used no closer than 30 cm (12 inches) to any part of the access point. Otherwise, degradation of the performance of this equipment could result.

## Brazil

Este equipamento não tem direito à proteção contra interferência prejudicial e não pode causar interferência em sistemas devidamente autorizados.

## Japan

ご使用になっている装置に VCCI マークが付いていましたら、次の説明文をお読み下さい。

この装置は、クラス B 情報技術装置です。この装置は、家庭環境で使用することを目的としていますが、この装置がラジオやテレビジョン受信機に近接して使用されると、受信障害を引き起こすことがあります。取扱説明書に従って正しい取り扱いをして下さい。

VCCI-B

## México

La operación de este equipo está sujeta a las siguientes dos condiciones: (1) es posible que este equipo o dispositivo no cause interferencia perjudicial y (2) este equipo o dispositivo debe aceptar cualquier interferencia, incluyendo la que pueda causar su operación no deseada.

Este equipo ha sido diseñado para operar con las antenas que enseguida se enlistan, en los puntos 3 de: [https://www.arubanetworks.com/assets/og/OG\\_AP-500Series.pdf](https://www.arubanetworks.com/assets/og/OG_AP-500Series.pdf) y para una ganancia máxima de antena de 8.5 dBi.

El uso con este equipo de antenas no incluidas en esta lista o que tengan una ganancia mayor que 8.5 dBi quedan prohibidas. La impedancia requerida de la antena es de 50 ohms.

## Morocco



## Нормативные требования Евразийского Экономического Союза

### Russia



НРЕ Russia: ООО "Хьюлетт Паккард Энтерпрайз" Российская Федерация, 125171, г. Москва, Ленинградское шоссе, 16А, стр.3, Телефон: +7 499 403 4248 Факс: +7 499 403 4677

'НРЕ Kazakhstan': ТОО «Хьюлетт-Паккард (К)», Республика Казахстан, 050040, г. Алматы, Бостандыкский район, проспект Аль-Фараби, 77/7, Телефон/факс: +7 727 355 35 50

### Kazakhstan

ЖШС "Хьюлетт Паккард Энтерпрайз" Ресей Федерациясы, 125171, Мәскеу, Ленинград тас жолы, 16А блок 3, Телефон: +7 499 403 4248 Факс: +7 499 403 4677

ЖШС «Хьюлетт-Паккард (К)», Қазақстан Республикасы, 050040, Алматы к., Бостандық ауданы, Әл-Фараби даңғылы, 77/7, Телефон/факс: +7 (727) 355 35 50

## Taiwan

### 第十二條

經型式認證合格之低功率射頻電機，非經許可，公司、商號或使用者均不得擅自變更頻率、加大功率或變更原設計之特性及功能。

### 第十四條

低功率射頻電機之使用不得影響飛航安全及干擾合法通信；經發現有干擾現象時，應立即停用，並改善至無干擾時方得繼續使用。

前項合法通信，指依電信法規定作業之無線電通信。

低功率射頻電機須忍受合法通信或工業、科學及醫療用電波輻射性電機設備之干擾。

## Contact Aruba

Main Site	<a href="https://www.arubanetworks.com">https://www.arubanetworks.com</a>
Support Site	<a href="https://support.arubanetworks.com">https://support.arubanetworks.com</a>
Airheads Social Forums and Knowledge Base	<a href="https://community.arubanetworks.com/">https://community.arubanetworks.com/</a>
North America Telephone	1-800-943-4526 1-408-754-1200
International Telephone	<a href="https://www.arubanetworks.com/support-services/contact-support/">https://www.arubanetworks.com/support-services/contact-support/</a>
Software Licensing Site	<a href="https://www.hpe.com/networking/support">https://www.hpe.com/networking/support</a>
End-of-Life Information	<a href="https://www.arubanetworks.com/support-services/end-of-life/">https://www.arubanetworks.com/support-services/end-of-life/</a>
Security Incident Response Team (SIRT)	<a href="https://www.arubanetworks.com/support-service/security-bulletins/">https://www.arubanetworks.com/support-service/security-bulletins/</a> Email: <a href="mailto:aruba-sirt@hpe.com">aruba-sirt@hpe.com</a>

### Copyright

© Copyright 2019 Hewlett Packard Enterprise Development LP

### Open Source Code

This product includes code licensed under the GNU General Public License, the GNU Lesser General Public License, and/or certain other open source licenses.

A complete machine-readable copy of the source code corresponding to such code is available upon request. This offer is valid to anyone in receipt of this information and shall expire three years following the date of the final distribution of this product version by Hewlett Packard Enterprise Company.

To obtain such source code, send a check or money order in the amount of US \$10.00 to:

Hewlett Packard Enterprise Company

Attn: General Counsel

6280 America Center Drive

San Jose, CA 94089

USA

### Warranty

This hardware product is protected by an Aruba warranty. For more details, visit [www.hpe.com/us/en/support.html](http://www.hpe.com/us/en/support.html)