



DFS MEASUREMENT REPORT

FCC ID: Q9DAPIN0503

Applicant: Hewlett Packard Enterprise Company

Product: ACCESS POINT

Model No.: APIN0503

Trademark:  

FCC Classification: Unlicensed National Information Infrastructure (NII)

FCC Rule Part(s): Part 15 Subpart E - 15.407 Section (h)(2)

Result: Complies

Received Date: 2022-12-19

Test Date: 2023-03-20 ~ 2023-03-28

Reviewed By:

Jame Yuan

Approved By:

Robin Wu



The test results relate only to the samples tested.

This equipment has been shown to be capable of compliance with the applicable technical standards as indicated in the measurement report and was tested in accordance with the measurement procedures specified in KDB 905462. Test results reported herein relate only to the item(s) tested.

The test report shall not be reproduced except in full without the written approval of MRT Technology (Suzhou) Co., Ltd.

Revision History

Report No.	Version	Description	Issue Date	Note
2212RSU034-U4	V01	Initial Report	2023-03-28	Valid

CONTENTS

Description	Page
1. General Information	5
1.1. Applicant	5
1.2. Manufacturer	5
1.3. Testing Facility	5
1.4. Product Information.....	6
1.5. Radio Specification under Test	6
1.6. Working Frequencies	7
1.7. Antenna Details.....	7
2. Test Configuration	8
2.1. Test Mode.....	8
2.2. Test Channel	8
2.3. Applied Standards.....	8
2.4. Test Environment Condition	8
3. DFS Detection Thresholds and Radar Test Waveforms	9
3.1. Applicability	9
3.2. DFS Devices Requirements.....	10
3.3. DFS Detection Threshold Values.....	12
3.4. Parameters of DFS Test Signals.....	13
3.5. Conducted Test Setup.....	16
4. Measuring Instrument	17
5. Test Result.....	18
5.1. Summary.....	18
5.2. Radar Waveform Calibration Measurement.....	19
5.2.1. Calibration Setup	19
5.2.2. Calibration Procedure	19
5.2.3. Calibration & Channel Loading Result.....	19
5.3. NII Detection Bandwidth Measurement	20
5.3.1. Test Limit	20
5.3.2. Test Procedure.....	20
5.3.3. Test Result	21
5.4. Initial Channel Availability Check Time Measurement	22
5.4.1. Test Limit	22
5.4.2. Test Procedure.....	22
5.4.3. Test Result	22
5.5. Radar Burst at the Beginning of the Channel Availability Check Time Measurement	23

5.5.1.	Test Limit	23
5.5.2.	Test Procedure	23
5.5.3.	Test Result	23
5.6.	Radar Burst at the End of the Channel Availability Check Time Measurement	24
5.6.1.	Test Limit	24
5.6.2.	Test Procedure	24
5.6.3.	Test Result	24
5.7.	In-Service Monitoring for Channel Move Time, Channel Closing Transmission Time and Non-Occupancy Period Measurement	25
5.7.1.	Test Limit	25
5.7.2.	Test Procedure	25
5.7.3.	Test Result	25
5.8.	Statistical Performance Check Measurement	26
5.8.1.	Test Limit	26
5.8.2.	Test Procedure	26
5.8.3.	Test Result	26
Appendix A – Test Result		27
A.1	Calibration Test Result	27
A.2	Channel Loading Test Result	29
A.3	NII Detection Bandwidth Test Result	31
A.4	Initial Channel Availability Check Time Test Result	34
A.5	Radar Burst at the Beginning of the Channel Availability Check Time Test Result	35
A.6	Radar Burst at the End of the Channel Availability Check Time Test Result	36
A.7	In-Service Monitoring for Channel Move Time, Channel Closing Transmission Time and Non-Occupancy Period Test Result	37
A.8	Statistical Performance Check	39
Appendix B – Test Setup Photograph		126
Appendix C – EUT Photograph		127

1.4. Product Information

Product Name	ACCESS POINT
Model No.	APIN0503
Serial No.	CNPMLGQ001 (AP), CNPMLGQ052 (client)
Software Version	ArubaOS_8.11.1.0_86351
Wi-Fi Specification	802.11a/b/g/n/ac/ax
Antenna Information	Refer to Clause 1.7
Operating Temp.	0 ~ 40 °C
Operating Environment	Indoor Use
Accessory	
PoE Injector	Model: ADH-15CR Input: 100-240V ~ 0.6A 50/60Hz Output: 55.0V=0.28A 15.4W
Note 1: The information of EUT was provided by the manufacturer, and the accuracy of the information shall be the responsibility of the manufacturer. Note 2: PoE Injector are not sold with the product.	

1.5. Radio Specification under Test

Frequency Range	For 802.11a/n-HT20/ac-VHT20/ax-HE20: 5260~5320MHz, 5500~5720MHz For 802.11n-HT40/ac-VHT40/ax-HE40: 5270~5310MHz, 5510~5710MHz For 802.11ac-VHT80/ax-HE80: 5290MHz, 5530MHz, 5610 MHz, 5690MHz	
Type of Modulation	802.11a/n/ac: OFDM 802.11ax: OFDMA	
Power-on cycle	Requires 102.3 seconds to complete its power-on cycle	
Uniform Spreading	For the 5250-5350MHz, 5470-5725 MHz bands, the Master device provides, on aggregate, uniform loading of the spectrum across all devices by selecting an operating channel among the available channels using a random algorithm.	
Channel Puncturing Function	<input type="checkbox"/> Supported	<input checked="" type="checkbox"/> Unsupported
Support RU	<input checked="" type="checkbox"/> Full RU	<input type="checkbox"/> Partial RU

1.6. Working Frequencies

802.11a/n-HT20/ac-VHT20/ax-HE20

Channel	Frequency	Channel	Frequency	Channel	Frequency
52	5260 MHz	56	5280 MHz	60	5300 MHz
64	5320 MHz	100	5500 MHz	104	5520 MHz
108	5540 MHz	112	5560 MHz	116	5580 MHz
120	5600 MHz	124	5620 MHz	128	5640 MHz
132	5660 MHz	136	5680 MHz	140	5700 MHz
144	5720 MHz	--	--	--	--

802.11n-HT40/ac-VHT40/ax-HE40

Channel	Frequency	Channel	Frequency	Channel	Frequency
54	5270 MHz	62	5310 MHz	102	5510 MHz
110	5550 MHz	118	5590 MHz	126	5630 MHz
134	5670 MHz	142	5710 MHz	--	--

802.11ac-VHT80/ax-HE80

Channel	Frequency	Channel	Frequency	Channel	Frequency
58	5290 MHz	106	5530 MHz	122	5610 MHz
138	5690 MHz	--	--	--	--

1.7. Antenna Details

Antenna Type	Frequency Band (GHz)	Max Peak Gain (dBi)	CDD Dir Gain (dBi)		BF Dir Gain (dBi)
			For Power	For PSD	
Wi-Fi Antenna (2*2 MIMO)					
PIFA	5.15 ~ 5.85	3.9	3.9	6.9	6.9

Note:

- 1, The EUT supports Cyclic Delay Diversity (CDD) mode, and CDD signals are correlated.
- 2, The EUT also supports Beam Forming mode, and the Beam Forming support 802.11n/ac/ax, not include 802.11a/b/g.
3. For beamforming operation, Aruba OS automatically backs power down based on a $10\log(N)$ factor based on CDD power.
4. The detail calculation method of directional gain refer to antenna specification.

2. Test Configuration

2.1. Test Mode

Mode 1: Working on AP mode
Mode 2: Working on mesh mode

2.2. Test Channel

Test Mode	Test Channel	Test Frequency
802.11ax-HE20	100	5500 MHz
802.11ax-HE40	102	5510 MHz
802.11ax-HE80	106	5530 MHz

2.3. Applied Standards

According to the specifications of the manufacturer, the EUT must comply with the requirements of the following standards:

- FCC Part 15.407 Section (h)(2)
- KDB 905462 D02v02
- KDB 905462 D04v01

2.4. Test Environment Condition

Ambient Temperature	15 ~ 35°C
Relative Humidity	20 ~ 75%RH

3. DFS Detection Thresholds and Radar Test Waveforms

3.1. Applicability

The following table from FCC KDB 905462 D02 NII DFS Compliance Procedures New Rules v02 lists the applicable requirements for the DFS testing.

Requirement	Operational Mode		
	Master	Client Without Radar Detection	Client With Radar Detection
Non-Occupancy Period	Yes	Not required	Yes
DFS Detection Threshold	Yes	Not required	Yes
Channel Availability Check Time	Yes	Not required	Not required
U-NII Detection Bandwidth	Yes	Not required	Yes

Table 3-1: Applicability of DFS Requirements Prior to Use of a Channel

Requirement	Operational Mode	
	Master Device or Client With Radar Detection	Client Without Radar Detection
DFS Detection Threshold	Yes	Not required
Channel Closing Transmission Time	Yes	Yes
Channel Move Time	Yes	Yes
U-NII Detection Bandwidth	Yes	Not required

Additional requirements for devices with multiple bandwidth modes	Master Device or Client with Radar Detection	Client Without Radar Detection
U-NII Detection Bandwidth and Statistical Performance Check	All BW modes must be tested	Not required
Channel Move Time and Channel Closing Transmission Time	Test using widest BW mode available	Test using the widest BW mode available for the link
All other tests	Any single BW mode	Not required

Note: Frequencies selected for statistical performance check should include several frequencies within the radar detection bandwidth and frequencies near the edge of the radar detection bandwidth. For 802.11 devices it is suggested to select frequencies in each of the bonded 20 MHz channels and the channel center frequency.

Table 3-2: Applicability of DFS Requirements during normal operation

3.2. DFS Devices Requirements

Per FCC KDB 905462 D02 NII DFS Compliance Procedures New Rules v02 the following are the requirements for Master Devices:

- (a) The Master Device will use DFS in order to detect Radar Waveforms with received signal strength above the DFS Detection Threshold in the 5250 ~ 5350 MHz and 5470 ~ 5725 MHz bands. DFS is not required in the 5150 ~ 5250 MHz or 5725 ~ 5825 MHz bands.
- (b) Before initiating a network on a Channel, the Master Device will perform a Channel Availability Check for a specified time duration (Channel Availability Check Time) to ensure that there is no radar system operating on the Channel, using DFS described under subsection a) above.
- (c) The Master Device initiates a U-NII network by transmitting control signals that will enable other U-NII devices to Associate with the Master Device.
- (d) During normal operation, the Master Device will monitor the Channel (In-Service Monitoring) to ensure that there is no radar system operating on the Channel, using DFS described under a).
- (e) If the Master Device has detected a Radar Waveform during In-Service Monitoring as described under d), the Operating Channel of the U-NII network is no longer an Available Channel. The Master Device will instruct all associated Client Device(s) to stop transmitting on this Channel within the Channel Move Time. The transmissions during the Channel Move Time will be limited to the Channel Closing Transmission Time.
- (f) Once the Master Device has detected a Radar Waveform it will not utilize the Channel for the duration of the Non-Occupancy Period.
- (g) If the Master Device delegates the In-Service Monitoring to a Client Device, then the combination will be tested to the requirements described under d) through f) above.

Channel Move Time and Channel Closing Transmission Time requirements are listed in the following table.

Parameter	Value
Non-occupancy period	Minimum 30 minutes
Channel Availability Check Time	60 seconds
Channel Move Time	10 seconds See Note 1.
Channel Closing Transmission Time	200 milliseconds + an aggregate of 60 milliseconds over remaining 10 second period. See Notes 1 and 2.
U-NII Detection Bandwidth	Minimum 100% of the U-NII 99% transmission power bandwidth. See Note 3.
<p>Note 1: Channel Move Time and the Channel Closing Transmission Time should be performed with Radar Type 0. The measurement timing begins at the end of the Radar Type 0 burst.</p> <p>Note 2: The Channel Closing Transmission Time is comprised of 200 milliseconds starting at the beginning of the Channel Move Time plus any additional intermittent control signals required to facilitate a Channel move (an aggregate of 60 milliseconds) during the remainder of the 10 second period. The aggregate duration of control signals will not count quiet periods in between transmissions.</p> <p>Note 3: During the U-NII Detection Bandwidth detection test, radar type 0 should be used. For each frequency step the minimum percentage of detection is 90 percent. Measurements are performed with no data traffic.</p>	

Table 3-3: DFS Response Requirements

3.3. DFS Detection Threshold Values

The DFS detection thresholds are defined for Master devices and Client Devices with In-service monitoring.

These detection thresholds are listed in the following table.

Maximum Transmit Power	Value (See Notes 1, 2, and 3)
EIRP \geq 200 milliwatt	-64 dBm
EIRP < 200 milliwatt and power spectral density < 10 dBm/MHz	-62 dBm
EIRP < 200 milliwatt that do not meet the power spectral density requirement	-64 dBm

Note 1: This is the level at the input of the receiver assuming a 0 dBi receive antenna.

Note 2: Throughout these test procedures an additional 1 dB has been added to the amplitude of the test transmission waveforms to account for variations in measurement equipment. This will ensure that the test signal is at or above the detection threshold level to trigger a DFS response.

Note3: EIRP is based on the highest antenna gain. For MIMO devices refer to KDB Publication 662911 D01.

Table 3-4: Detection Thresholds for Master Devices and Client Devices with Radar Detection

3.4. Parameters of DFS Test Signals

This section provides the parameters for required test waveforms, minimum percentage of successful detections, and the minimum number of trials that must be used for determining DFS conformance. Step intervals of 0.1 microsecond for Pulse Width, 1 microsecond for PRI, 1 MHz for chirp width and 1 for the number of pulses will be utilized for the random determination of specific test waveforms.

Short Pulse Radar Test Waveforms

Radar Type	Pulse Width (μsec)	PRI (μsec)	Number of Pulses	Minimum Percentage of Successful Detection	Minimum Number of Trials
0	1	1428	18	See Note 1	See Note 1
1	1	Test A: 15 unique PRI values randomly selected from the list of 23 PRI values in Table 3-6	$\text{Roundup} \left\{ \left(\frac{1}{360} \right) \cdot \left(\frac{19 \cdot 10^6}{\text{PRI}_{\mu\text{sec}}} \right) \right\}$	60%	30
		Test B: 15 unique PRI values randomly selected within the range of 518-3066 μsec, with a minimum increment of 1 μsec, excluding PRI values selected in Test A			
2	1-5	150-230	23-29	60%	30
3	6-10	200-500	16-18	60%	30
4	11-20	200-500	12-16	60%	30
Aggregate (Radar Types 1-4)				80%	120
Note: Short Pulse Radar Type 0 should be used for the detection bandwidth test, channel move time, and channel closing time tests.					

Table 3-5: Parameters for Short Pulse Radar Waveforms

A minimum of 30 unique waveforms are required for each of the Short Pulse Radar Types 2 through 4. If more than 30 waveforms are used for Short Pulse Radar Types 2 through 4, then each additional waveform must also be unique and not repeated from the previous waveforms.

Pulse Repetition Frequency Number	Pulse Repetition Frequency (Pulses Per Second)	Pulse Repetition Interval (Microseconds)
1	1930.5	518
2	1858.7	538
3	1792.1	558
4	1730.1	578
5	1672.2	598
6	1618.1	618
7	1567.4	638
8	1519.8	658
9	1474.9	678
10	1432.7	698
11	1392.8	718
12	1355	738
13	1319.3	758
14	1285.3	778
15	1253.1	798
16	1222.5	818
17	1193.3	838
18	1165.6	858
19	1139	878
20	1113.6	898
21	1089.3	918
22	1066.1	938
23	326.2	3066

Table 3-6: Pulse Repetition Intervals Values for Test A

Long Pulse Radar Test Waveform

Radar Type	Pulse Width (μsec)	Chirp Width (MHz)	PRI (μsec)	Number of Pulses per Burst	Number of Bursts	Minimum Percentage of Successful Detection	Minimum Number of Trials
5	50 - 100	5 - 20	1000 - 2000	1 - 3	8 - 20	80%	30

Table 3-7: Parameters for Long Pulse Radar Waveforms

The parameters for this waveform are randomly chosen. Thirty unique waveforms are required for the Long Pulse Radar Type waveforms. If more than 30 waveforms are used for the Long Pulse Radar Type waveforms, then each additional waveform must also be unique and not repeated from the previous waveforms.

Frequency Hopping Radar Test Waveform

Radar Type	Pulse Width (μsec)	PRI (μsec)	Pulses Per Hop	Hopping Rate (kHz)	Hopping Sequence Length (msec)	Minimum Percentage of Successful Detection	Minimum Number of Trials
6	1	333	9	0.333	300	70%	30

Table 3-8: Parameters for Frequency Hopping Radar Waveforms

For the Frequency Hopping Radar Type, the same Burst parameters are used for each waveform. The hopping sequence is different for each waveform and a 100-length segment is selected from the hopping sequence defined by the following algorithm:

The first frequency in a hopping sequence is selected randomly from the group of 475 integer frequencies from 5250 – 5724MHz. Next, the frequency that was just chosen is removed from the group and a frequency is randomly selected from the remaining 474 frequencies in the group. This process continues until all 475 frequencies are chosen for the set. For selection of a random frequency, the frequencies remaining within the group are always treated as equally likely.

3.5. Conducted Test Setup

The FCC KDB 905462 D02 NII DFS Compliance Procedures New Rules v02 describes a radiated test setup and a conducted test setup. The conducted test setup was used for this testing. Figure 3-1 shows the typical test setup.

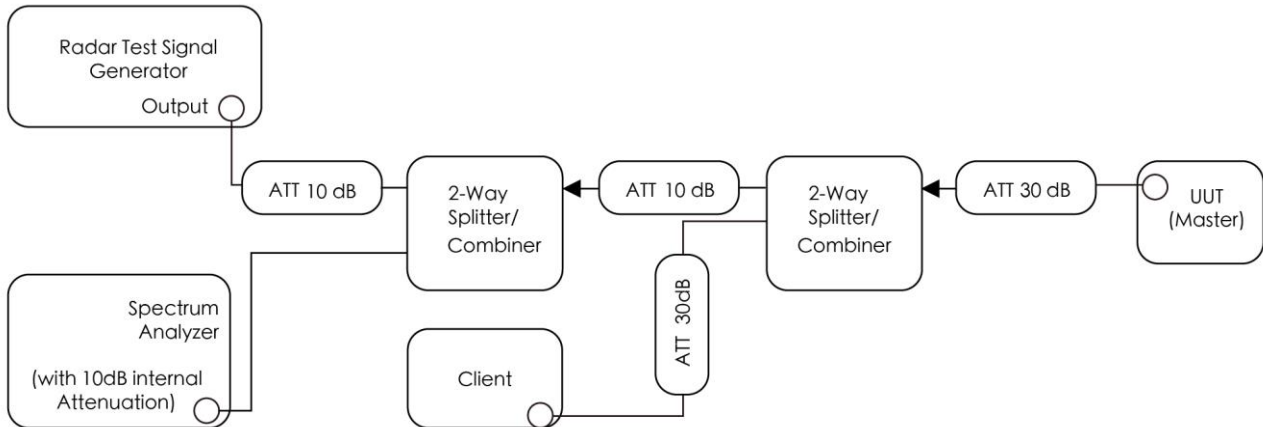

Figure 3-1: Conducted Test Setup where UUT is a Master and Radar Test Waveforms are injected into the Master

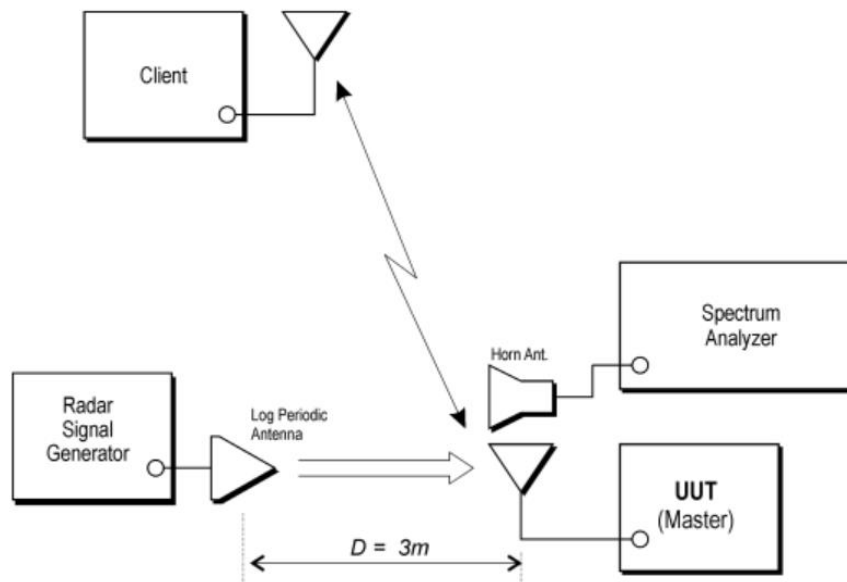

Figure 3-2: Radiated Test Setup where UUT is a master mode and Radar Test Waveforms are injected into the UUT

4. Measuring Instrument

Instrument Name	Manufacturer	Model No.	Asset No.	Cali. Interval	Cal. Due Date	Test Site
Signal Generator	Keysight	N5182B	MRTSUE06605	1 year	2023-10-25	SIP-TR2/SIP-AC3
Signal Analyzer	Keysight	N9010B	MRTSUE07028	1 year	2023-11-25	SIP-TR2/SIP-AC3
Thermohygrometer	testo	608-H1	MRTSUE11109	1 year	2024-03-03	SIP-TR2
Horn Antenna	Schwarzbeck	BBHA 9120D	MRTSUE06648	1 year	2023-10-22	SIP-AC3
Anechoic Chamber	RIKEN	SIP-AC3	MRTSUE06782	1 year	2023-12-22	SIP-AC3
Thermohygrometer	testo	608-H1	MRTSUE06619	1 year	2023-11-01	SIP-AC3

Client Information

Instrument	Manufacturer	Type No.	Certification Number
Wi-Fi Module	Intel	AX200NGW	FCC ID: PD9AX200NG

Software	Version	Manufacturer	Function
Signal Studio	V2.2.0.0	Keysight	DFS Test Software

5. Test Result

5.1. Summary

Parameter	Verdict	Reference
NII Detection Bandwidth Measurement	Pass	Section 5.3
Initial Channel Availability Check Time	Pass	Section 5.4
Radar Burst at the Beginning of the Channel Availability Check Time	Pass	Section 5.5
Radar Burst at the End of the Channel Availability Check Time	Pass	Section 5.6
In-Service Monitoring for Channel Move Time, Channel Closing Transmission Time	Pass	Section 5.7
Non-Occupancy Period	Pass	Section 5.7
Statistical Performance Check	Pass	Section 5.8

Note 1: For mesh mode, we just test the In-service monitoring item declared by the applicant.

Note 2: We used the worst-case level -64dBm as DFS detection thresholds for all DFS testing.

Note 3: Radiated test method was used in Statistical Performance Check item, conducted test method was used in any other items.

5.2. Radar Waveform Calibration Measurement

5.2.1. Calibration Setup

The conducted test setup was used for this calibration testing. Figure 3-2 shows the typical test setup.

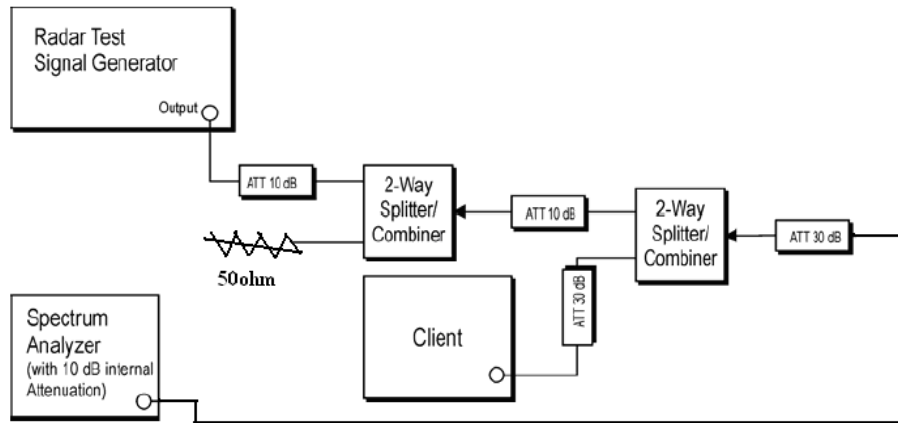

Figure 3-2: Conducted Test Setup

5.2.2. Calibration Procedure

The Interference Radar Detection Threshold Level is $(-64\text{dBm}) + (0) [\text{dBi}] + 1 \text{ dB} = -63 \text{ dBm}$ that had been taken into account the output power range and antenna gain. The above equipment setup was used to calibrate the conducted Radar Waveform. A vector signal generator was utilized to establish the test signal level for each radar type. During this process there were replace 50ohm terminal form Master and Client device and no transmissions by either the Master or Client Device. The spectrum analyzer was switched to the zero span (Time Domain) at the frequency of the Radar Waveform generator. Peak detection was used. The spectrum analyzer resolution bandwidth (RBW) and video bandwidth (VBW) were set to at least 3MHz. The vector signal generator amplitude was set so that the power level measured at the spectrum analyzer was $(-64\text{dBm}) + (0) [\text{dBi}] + 1 \text{ dB} = -63\text{dBm}$. Capture the spectrum analyzer plots on short pulse radar types, long pulse radar type and hopping radar waveform.

5.2.3. Calibration & Channel Loading Result

Refer to Appendix A.1 & A.2.

5.3. NII Detection Bandwidth Measurement

5.3.1. Test Limit

Minimum 100% of the NII 99% transmission power bandwidth. During the U-NII Detection Bandwidth detection test, each frequency step the minimum percentage of detection is 90 percent. Measurements are performed with no data traffic.

5.3.2. Test Procedure

1. Adjust the equipment to produce a single Burst of any one of the Short Pulse Radar Types 0-4 in Table 3-5 at the center frequency of the EUT Operating Channel at the specified DFS Detection Threshold level.
2. The generating equipment is configured as shown in the Conducted Test Setup above section 3.5.
3. The EUT is set up as a stand-alone device (no associated Client or Master, as appropriate) and no traffic. Frame based systems will be set to a talk/listen ratio reflecting the worst case (maximum) that is user configurable during this test.
4. Generate a single radar Burst, and note the response of the EUT. Repeat for a minimum of 10 trials. The EUT must detect the Radar Waveform using the specified U-NII Detection Bandwidth criterion shown in Table 3-5. In cases where the channel bandwidth may exceed past the DFS band edge on specific channels (i.e., 802.11ac or wideband frame based systems) select a channel that has the entire emission bandwidth within the DFS band. If this is not possible, test the detection BW to the DFS band edge.
5. Starting at the center frequency of the UUT operating Channel, increase the radar frequency in 5 MHz steps, repeating the above test sequence, until the detection rate falls below the U-NII Detection Bandwidth criterion specified in Table 3-3. Repeat this measurement in 1MHz steps at frequencies 5 MHz below where the detection rate begins to fall. Record the highest frequency (denote as FH) at which detection is greater than or equal to the U-NII Detection Bandwidth criterion. Recording the detection rate at frequencies above FH is not required to demonstrate compliance.
6. Starting at the center frequency of the EUT operating Channel, decrease the radar frequency in 1 MHz steps, repeating the above item 4 test sequence, until the detection rate falls below the U-NII Detection Bandwidth criterion. Record the lowest frequency (denote as FL) at which detection is greater than or equal to the U-NII Detection Bandwidth criterion. Recording the detection rate at frequencies below FL is not required to demonstrate compliance.
7. The U-NII Detection Bandwidth is calculated as follows: $U\text{-NII Detection Bandwidth} = FH - FL$
8. The U-NII Detection Bandwidth must be at least 100% of the EUT transmitter 99% power, otherwise, the

EUT does not comply with DFS requirements.

5.3.3. Test Result

Refer to Appendix A.3.

5.4. Initial Channel Availability Check Time Measurement

5.4.1. Test Limit

The EUT shall perform a Channel Availability Check to ensure that there is no radar operating on the channel. After power-up sequence, receive at least 1 minute on the intended operating frequency.

5.4.2. Test Procedure

1. The U-NII devices will be powered on and be instructed to operate on the appropriate U-NII Channel that must incorporate DFS functions. At the same time the EUT is powered on, the spectrum analyzer will be set to zero span mode with a 3 MHz RBW and 3 MHz VBW on the Channel occupied by the radar (Chr) with a 2.5 minute sweep time. The spectrum analyzer's sweep will be started at the same time power is applied to the U-NII device.
2. The EUT should not transmit any beacon or data transmissions until at least 1 minute after the completion of the power-on cycle.
3. Confirm that the EUT initiates transmission on the channel. Measurement system showing its nominal noise floor is marker1.

5.4.3. Test Result

Refer to Appendix A.4.

5.5. Radar Burst at the Beginning of the Channel Availability Check Time Measurement

5.5.1. Test Limit

In beginning of the Channel Availability Check (CAC) Time, radar is detected on this channel, select another intended channel and perform a CAC on that channel.

5.5.2. Test Procedure

1. The steps below define the procedure to verify successful radar detection on the selected Channel during a period equal to the Channel Availability Check Time and avoidance of operation on that Channel when a radar Burst with a level equal to the DFS Detection Threshold + 1 dB occurs at the beginning of the Channel Availability Check Time.
2. The EUT is in completion power-up cycle (from T0 to T1). T1 denotes the instant when the EUT has completed its power-up sequence. The Channel Availability Check Time commences at instant T1 and will end no sooner than T1 + 60 seconds. A single Burst of one of Short Pulse Radar Types 0-4 at DFS Detection Threshold + 1 dB will commence within a 6 second window starting at T1.
3. Visual indication on the EUT of successful detection of the radar Burst will be recorded and reported. Observation of emissions will continue for 2.5 minutes after the radar Burst has been generated. Verify that during the 2.5 minutes measurement window no EUT transmissions occurred.

5.5.3. Test Result

Refer to Appendix A.5.

5.6. Radar Burst at the End of the Channel Availability Check Time Measurement

5.6.1. Test Limit

In the end of Channel Availability Check (CAC) Time, radar is detected on this channel, select another intended channel and perform a CAC on that channel.

5.6.2. Test Procedure

1. The steps below define the procedure to verify successful radar detection on the selected Channel during a period equal to the Channel Availability Check Time and avoidance of operation on that Channel when a radar Burst with a level equal to the DFS Detection Threshold + 1 dB occurs at the beginning of the Channel Availability Check Time.
2. The EUT is powered on at T0. T1 denotes the instant when the EUT has completed its power-up sequence. The Channel Availability Check Time commences at instant T1 and will end no sooner than T1 + 60 seconds. A single Burst of one of Short Pulse Radar Types 0-4 at DFS Detection Threshold + 1 dB will commence within a 6 second window starting at T1+ 54 seconds.
3. Visual indication on the EUT of successful detection of the radar Burst will be recorded and reported. Observation of emissions will continue for 2.5 minutes after the radar Burst has been generated. Verify that during the 2.5 minutes measurement window no EUT transmissions occurred.

5.6.3. Test Result

Refer to Appendix A.6.

5.7. In-Service Monitoring for Channel Move Time, Channel Closing Transmission Time and Non-Occupancy Period Measurement

5.7.1. Test Limit

The EUT has In-Service Monitoring function to continuously monitor the radar signals. If the radar is detected, must leave the channel (Shutdown). The Channel Move Time to cease all transmissions on the current channel upon detection of a Radar Waveform above the DFS Detection Threshold within 10 sec. The total duration of Channel Closing Transmission Time is 260ms, consisting of data signals and the aggregate of control signals, by a U-NII device during the Channel Move Time. The Non-Occupancy Period time is 30 minute during which a Channel will not be utilized after a Radar Waveform is detected on that Channel.

5.7.2. Test Procedure

1. The test should be performed with Radar Type 0. The measurement timing begins at the end of the Radar Type 0.
2. When the radar burst with a level equal to the DFS Detection Threshold + 1dB is generated on the Operating Channel of the U-NII device. A U-NII device operating as a Master Device will associate with the Client Device at Channel. Stream the MPEG test file from the Master Device to the Client Device on the selected Channel for the entire period of the test. At time T0 the Radar Waveform generator sends a Burst of pulses for each of the radar types at Detection Threshold + 1dB.
3. Observe the transmissions of the EUT at the end of the radar Burst on the Operating Channel. Measure and record the transmissions from the EUT during the observation time (Channel Move Time).
4. Measurement of the aggregate duration of the Channel Closing Transmission Time method. With the spectrum analyzer set to zero span tuned to the center frequency of the EUT operating channel at the radar simulated frequency, peak detection, and max hold, the dwell time per bin is given by: $Dwell (1.5ms) = S (12 \text{ sec}) / B (8000)$; where Dwell is the dwell time per spectrum analyzer sampling bin, S is the sweep time and B is the number of spectrum analyzer sampling bins. An upper bound of the aggregate duration of the intermittent control signals of Channel Closing Transmission Time is calculated by: $C = N \times Dwell$; where C is the Closing Time, N is the number of spectrum analyzer sampling bins showing a U-NII transmission and Dwell is the dwell time per bin.
5. Measure the EUT for more than 30 minutes following the channel close/move time to verify that the EUT does not resume any transmissions on this Channel.

5.7.3. Test Result

Refer to Appendix A.7.

5.8. Statistical Performance Check Measurement

5.8.1. Test Limit

The minimum percentage of successful detection requirements found in below table when a radar burst with a level equal to the DFS Detection Threshold + 1dB is generated on the Operating Channel of the U-NII device (In- Service Monitoring).

Radar Type	Minimum Number of Trails	Detection Probability
0	30	$P_d \geq 60\%$
1	30(15 of test A and 15 of test B)	$P_d \geq 60\%$
2	30	$P_d \geq 60\%$
3	30	$P_d \geq 60\%$
4	30	$P_d \geq 60\%$
Aggregate (Radar Types 1-4)	120	$P_d \geq 80\%$
5	30	$P_d \geq 80\%$
6	30	$P_d \geq 70\%$

Note: The percentage of successful detection is calculated by:
 $(\text{Total Waveform Detections} / \text{Total Waveform Trails}) * 100 = \text{Probability of Detection Radar Waveform}$
 In addition an aggregate minimum percentage of successful detection across all Short Pulse Radar Types 1-4 is required and is calculated as follows: $(P_{d1} + P_{d2} + P_{d3} + P_{d4}) / 4$.

5.8.2. Test Procedure

1. Stream the MPEG test file from the Master Device to the Client Device on the test Channel for the entire period of the test.
2. At time T0 the Radar Waveform generator sends the individual waveform for each of the Radar Types 1-6, at levels equal to the DFS Detection Threshold + 1dB, on the Operating Channel.
3. Observe the transmissions of the EUT at the end of the Burst on the Operating Channel for duration greater than 10 seconds for Short Pulse Radar Types 0 to ensure detection occurs.
4. Observe the transmissions of the EUT at the end of the Burst on the Operating Channel for duration greater than 22 seconds for Long Pulse Radar Type 5 to ensure detection occurs.
5. The device can utilize a test mode to demonstrate when detection occurs to prevent the need to reset the device between trial runs.
6. The Minimum number of trails, minimum percentage of successful detection and the average minimum percentage of successful detection are found in below table

5.8.3. Test Result

Refer to Appendix A.8.

Appendix A – Test Result

A.1 Calibration Test Result

Test Site	SIP-TR2	Test Engineer	Alisa Deng
Test Date	2023-03-22		

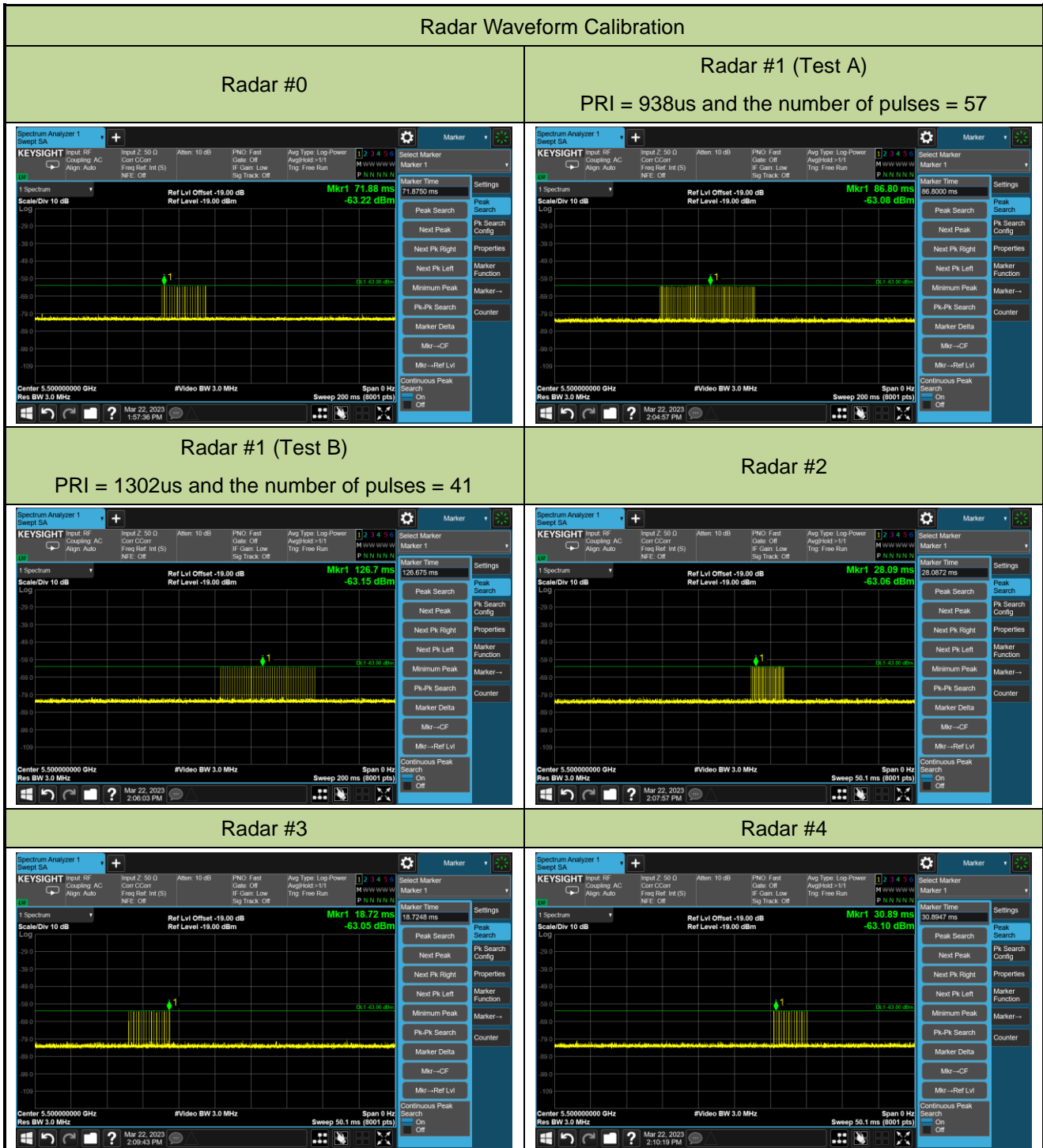



A.2 Channel Loading Test Result

Test Site	SIP-TR2	Test Engineer	Alisa Deng
Test Date	2023-03-22~2023-03-28	Test Mode	Mode 1

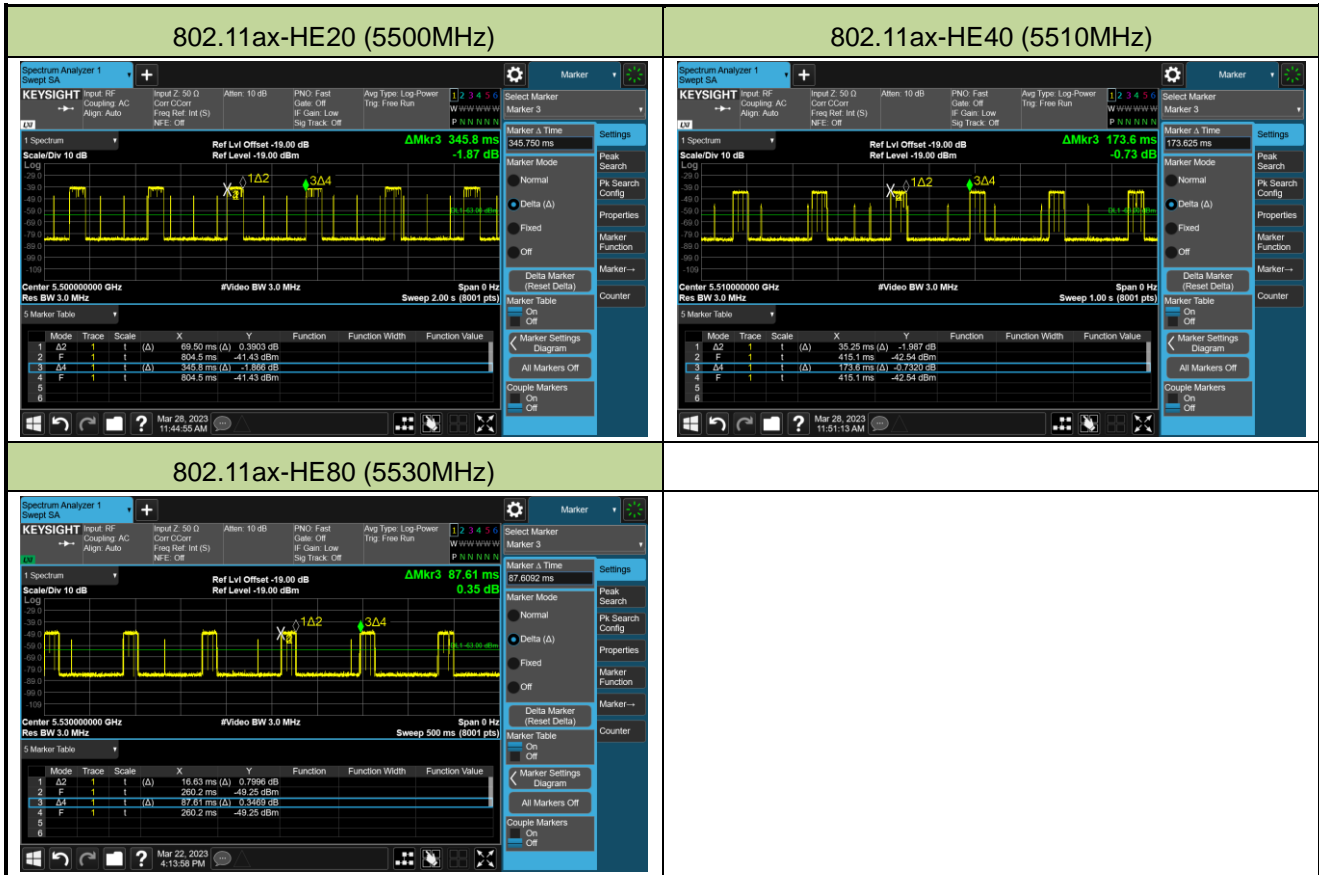

Test Mode	Test Frequency	Packet ratio	Requirement ratio	Test Result
802.11ax-HE20	5500 MHz	20.10%	≥ 17%	Pass
802.11ax-HE40	5510 MHz	20.31%	≥ 17%	Pass
802.11ax-HE80	5530 MHz	18.98%	≥ 17%	Pass

Note: System testing was performed with the designated iperf test file. This file is used by IP and Frame based systems for loading the test channel during the In-service compliance testing of the U-NII device.

Packet ratio = Time On / (Time On + Off Time).

Test Site	SIP-TR2	Test Engineer	Alisa Deng
Test Date	2023-03-20	Test Mode	Mode 2

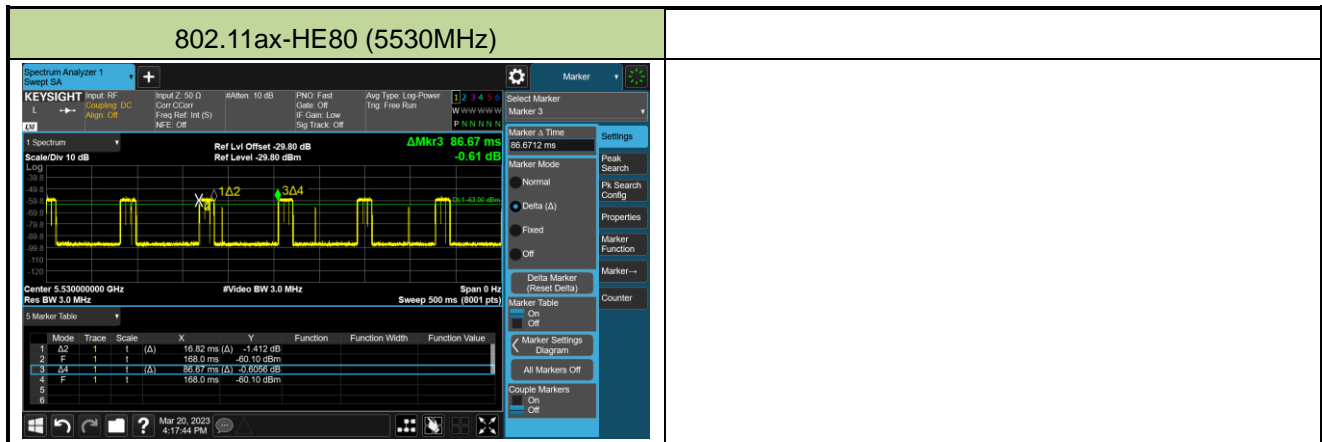

Test Mode	Test Frequency	Packet ratio	Requirement ratio	Test Result
802.11ax-HE80	5530 MHz	19.41%	≥ 17%	Pass

Note: System testing was performed with the designated iperf test file. This file is used by IP and Frame based systems for loading the test channel during the In-service compliance testing of the U-NII device.
 Packet ratio = Time On / (Time On + Off Time).

A.3 NII Detection Bandwidth Test Result

Test Site	SIP-TR2	Test Engineer	Alisa Deng
Test Date	2023-03-22		
Test Item	Detection Bandwidth (802.11ax-HE20 mode - 5500MHz)		

Radar Frequency (MHz)	DFS Detection Trials (1=Detection, 0= No Detection)										Detection Rate (%)
	1	2	3	4	5	6	7	8	9	10	
5489	0	0	0	0	0	0	0	0	0	0	0
5490 F _L	1	1	1	1	1	1	1	1	1	1	1
5495	1	1	1	1	1	1	1	1	1	1	1
5500	1	1	1	1	1	1	1	1	1	1	1
5505	1	1	1	1	1	1	1	1	1	1	1
5510 F _H	1	1	1	1	1	1	1	1	1	1	1
5511	0	0	0	0	0	0	0	0	0	0	0

Note 1: All NII channels for this device have identical Channel bandwidths. Therefore, all DFS testing was done at 5500MHz. The 99% channel bandwidth is 19.048MHz. (See the 99% BW section of the RF report for further measurement details).

Note 2: Detection Bandwidth = $F_H - F_L = 5510\text{MHz} - 5490\text{MHz} = 20\text{MHz}$

Note 3: NII Detection Bandwidth Min. Limit (MHz): $19.048\text{MHz} \times 100\% = 19.048\text{MHz}$.

Test Site	SIP-TR2	Test Engineer	Alisa Deng
Test Date	2023-03-22		
Test Item	Detection Bandwidth (802.11ax-HE40 mode - 5510MHz)		

Radar Frequency (MHz)	DFS Detection Trials (1=Detection, 0= No Detection)										Detection Rate (%)
	1	2	3	4	5	6	7	8	9	10	
5490	0	0	0	0	0	0	0	0	0	0	0
5491 F _L	1	1	1	1	1	1	1	1	1	1	100
5492	1	1	1	1	1	1	1	1	1	1	100
5493	1	1	1	1	1	1	1	1	1	1	100
5494	1	1	1	1	1	1	1	1	1	1	100
5495	1	1	1	1	1	1	1	1	1	1	100
5500	1	1	1	1	1	1	1	1	1	1	100
5505	1	1	1	1	1	1	1	1	1	1	100
5510	1	1	1	1	1	1	1	1	1	1	100
5515	1	1	1	1	1	1	1	1	1	1	100
5520	1	1	1	1	1	1	1	1	1	1	100
5525	1	1	1	1	1	1	1	1	1	1	100
5526	1	1	1	1	1	1	1	1	1	1	100
5527	1	1	1	1	1	1	1	1	1	1	100
5528	1	1	1	1	1	1	1	1	1	1	100
5529 F _H	1	1	1	1	1	1	1	1	1	1	100
5530	0	0	0	0	0	0	0	0	0	0	0

Note 1: All NII channels for this device have identical Channel bandwidths. Therefore, all DFS testing was done at 5510MHz. The 99% channel bandwidth is 37.505MHz. (See the 99% BW section of the RF report for further measurement details).

Note 2: Detection Bandwidth = F_H - F_L = 5529MHz - 5491MHz = 38MHz.

Note 3: NII Detection Bandwidth Min. Limit (MHz): 37.505MHz x 100% = 37.505MHz.

Test Site	SIP-TR2	Test Engineer	Alisa Deng
Test Date	2023-03-22		
Test Item	Detection Bandwidth (802.11ax-HE80 mode - 5530MHz)		

Radar Frequency (MHz)	DFS Detection Trials (1=Detection, 0= No Detection)										Detection Rate (%)
	1	2	3	4	5	6	7	8	9	10	
5490	0	0	0	0	0	0	0	0	0	0	0
5491 F _L	1	1	1	1	1	1	1	1	1	1	1
5492	1	1	1	1	1	1	1	1	1	1	1
5493	1	1	1	1	1	1	1	1	1	1	1
5494	1	1	1	1	1	1	1	1	1	1	1
5495	1	1	1	1	1	1	1	1	1	1	1
5500	1	1	1	1	1	1	1	1	1	1	1
5505	1	1	1	1	1	1	1	1	1	1	1
5510	1	1	1	1	1	1	1	1	1	1	1
5515	1	1	1	1	1	1	1	1	1	1	1
5520	1	1	1	1	1	1	1	1	1	1	1
5525	1	1	1	1	1	1	1	1	1	1	1
5530	1	1	1	1	1	1	1	1	1	1	1
5535	1	1	1	1	1	1	1	1	1	1	1
5540	1	1	1	1	1	1	1	1	1	1	1
5545	1	1	1	1	1	1	1	1	1	1	1
5550	1	1	1	1	1	1	1	1	1	1	1
5555	1	1	1	1	1	1	1	1	1	1	1
5560	1	1	1	1	1	1	1	1	1	1	1
5565	1	1	1	1	1	1	1	1	1	1	1
5566	1	1	1	1	1	1	1	1	1	1	1
5567	1	1	1	1	1	1	1	1	1	1	1
5568	1	1	1	1	1	1	1	1	1	1	1
5569 F _H	1	1	1	1	1	1	1	1	1	1	1
5570	0	0	0	0	0	0	0	0	0	0	0

Note 1: All NII channels for this device have identical Channel bandwidths. Therefore, all DFS testing was done at 5530MHz. The 99% channel bandwidth is 76.887MHz. (See the 99% BW section of the RF report for further measurement details).

Note 2: Detection Bandwidth = F_H - F_L = 5569MHz - 5491MHz = 78MHz.

Note 3: NII Detection Bandwidth Min. Limit (MHz): 76.887MHz x 100% = 76.887MHz.

A.4 Initial Channel Availability Check Time Test Result

Test Site	SIP-TR2	Test Engineer	Alisa Deng
Test Date	2023-03-22		
Test Item	Initial Channel Availability Check Time (802.11ax-HE20 mode - 5500MHz)		

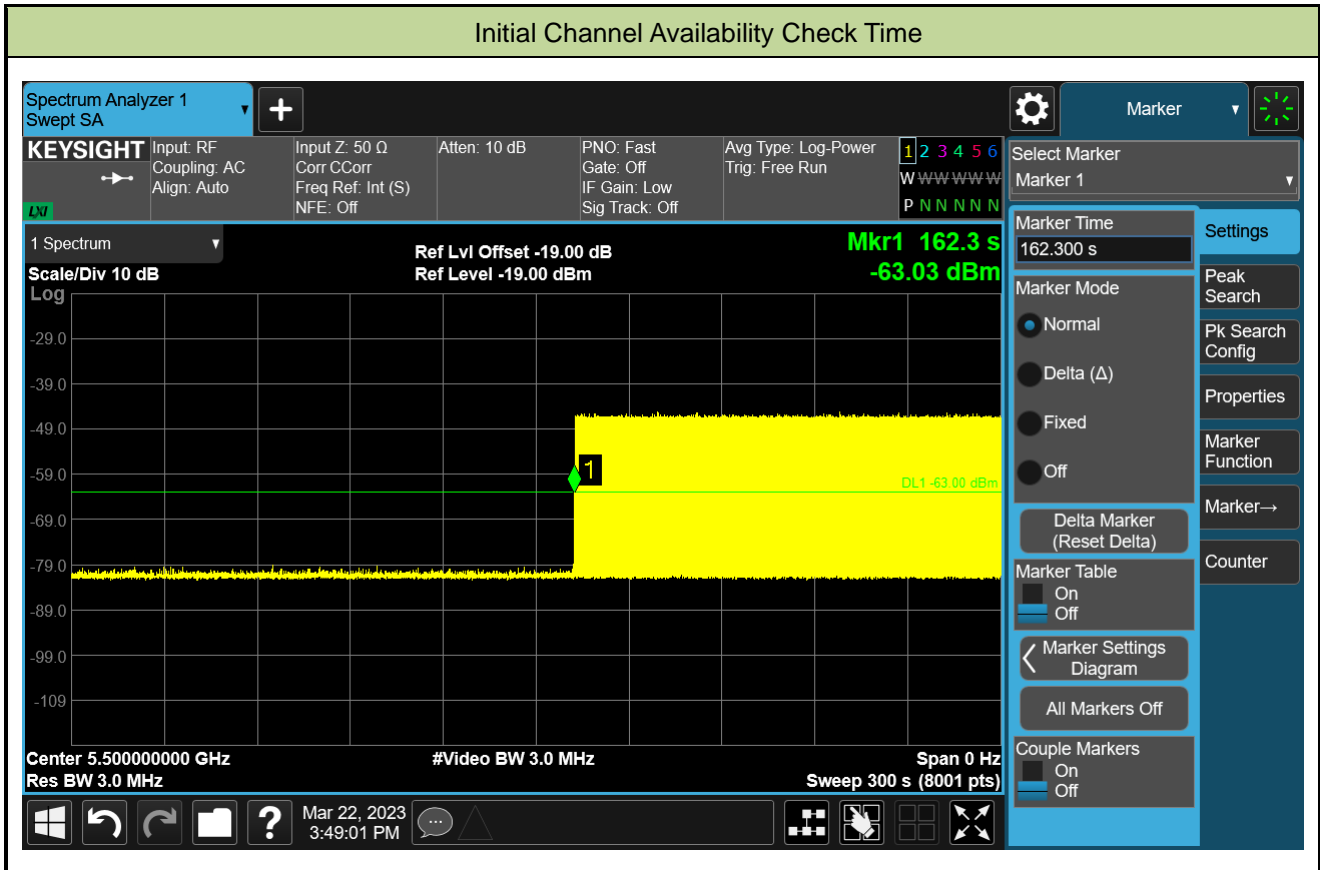

Note: The EUT does not transmit any beacon or data transmissions until at least 1 minute after the completion of the power-on cycle (102.3 sec). Initial beacons/data transmissions are indicated by marker 1 (162.3 sec).

A.5 Radar Burst at the Beginning of the Channel Availability Check Time Test Result

Test Site	SIP-TR2	Test Engineer	Alisa Deng
Test Date	2023-03-22		
Test Item	Beginning of the Channel Availability Check Time (802.11ax-HE20 mode - 5500MHz)		

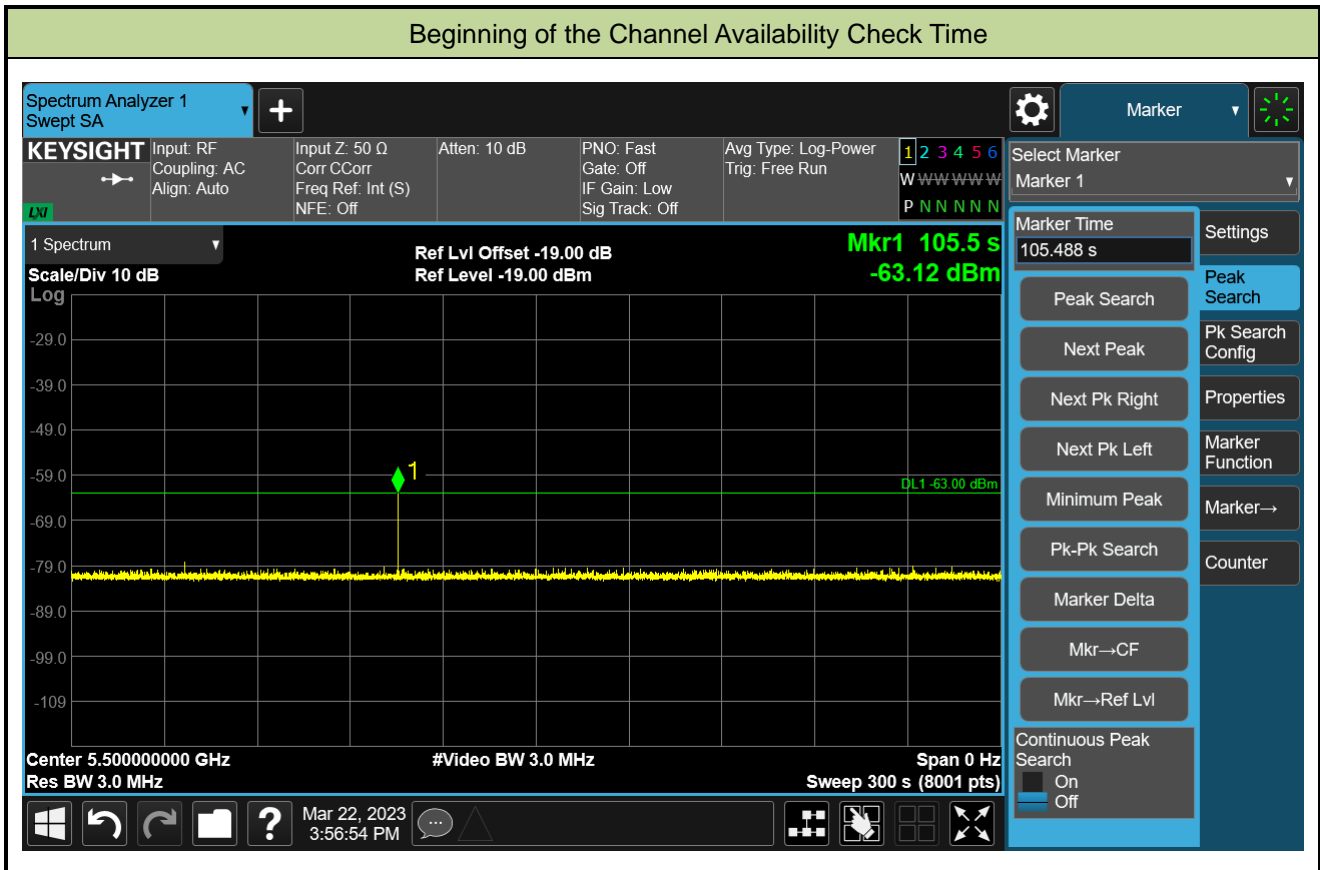

A.6 Radar Burst at the End of the Channel Availability Check Time Test Result

Test Site	SIP-TR2	Test Engineer	Alisa Deng
Test Date	2023-03-22		
Test Item	End of the Channel Availability Check Time (802.11ax-HE20 mode - 5500MHz)		

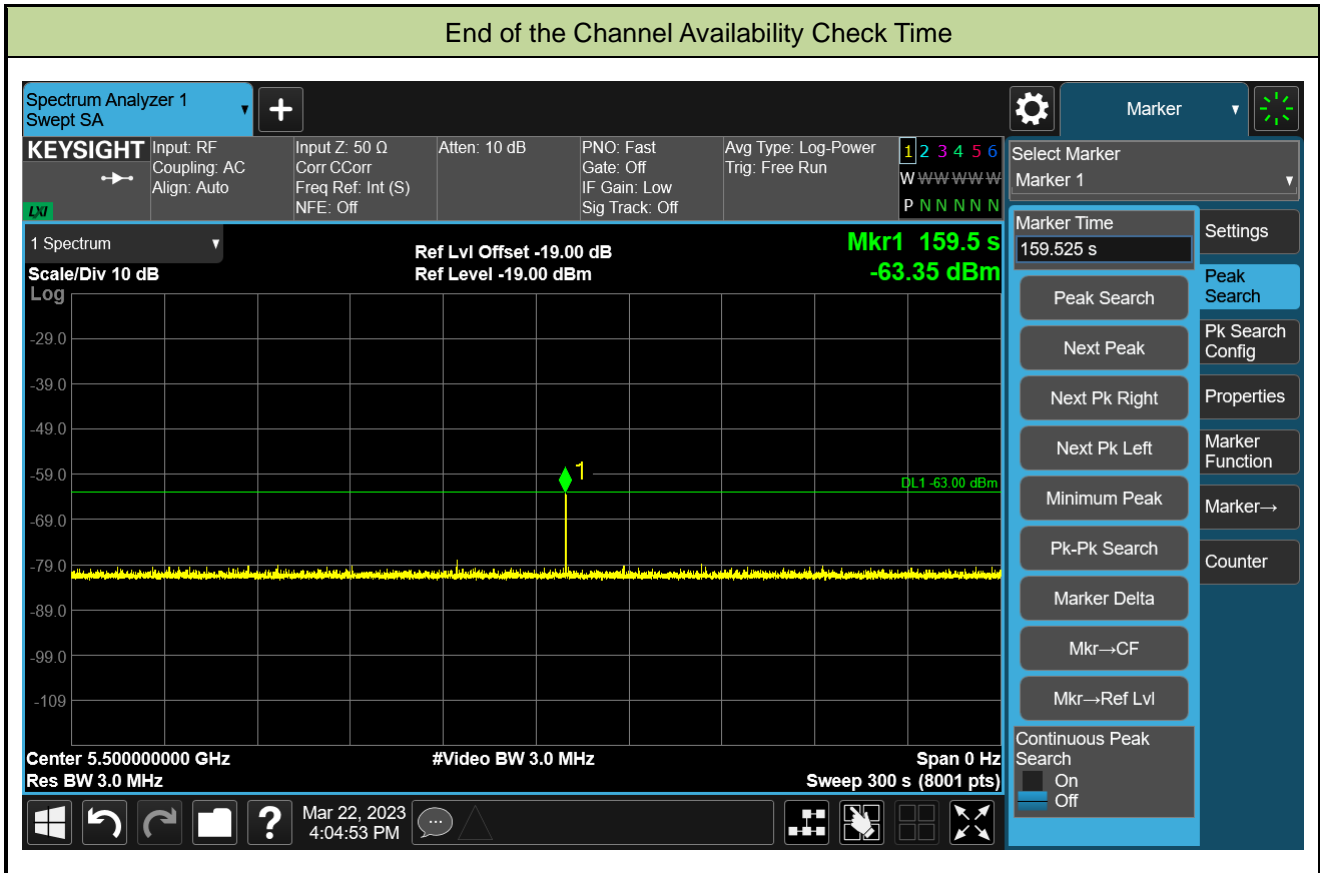

A.7 In-Service Monitoring for Channel Move Time, Channel Closing Transmission Time and Non-Occupancy Period Test Result

Test Site	SIP-TR2	Test Engineer	Alisa Deng
Test Date	2023-03-22		
Test Item	Channel Move Time and Channel Closing Transmission Time (802.11ax-HE80 mode - 5530MHz)		
Test Mode	Mode 1		

Channel Move Time and Channel Closing Transmission Time

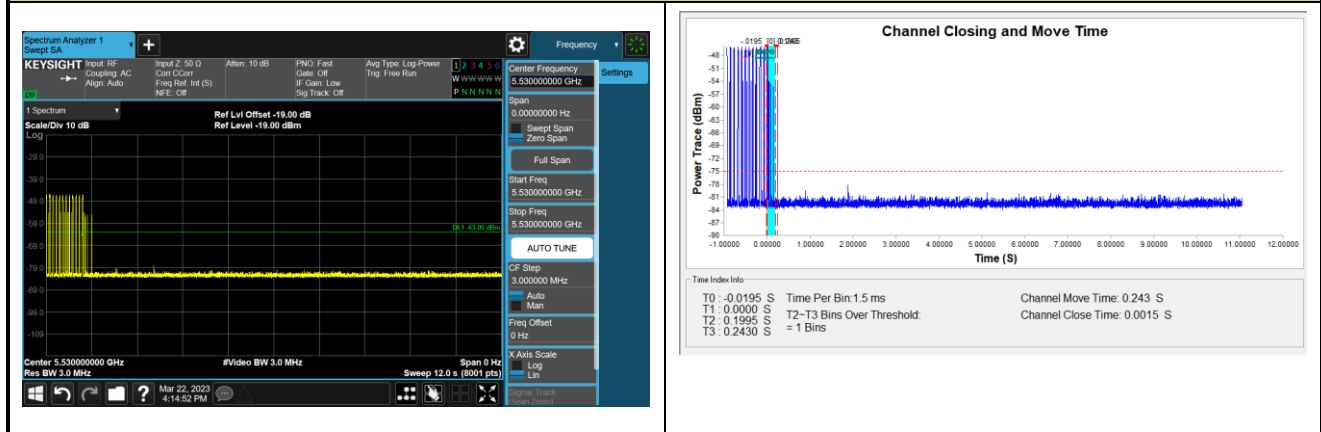

Non-Occupancy Period

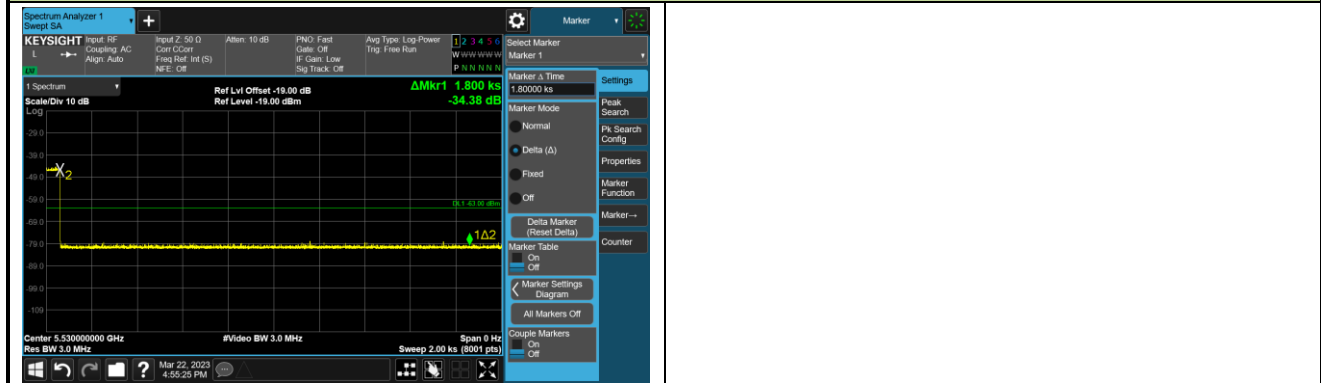

Parameter	Test Result	Limit
Channel Move Time (s)	0.243s	<10s
Channel Closing Transmission Time (ms) (Note)	1.5ms	< 60ms
Non-Occupancy Period (min)	≥ 30min	≥ 30 min

Note: The Channel Closing Transmission Time is comprised of 200 milliseconds starting at the beginning of the Channel Move Time plus any additional intermittent control signals required to facilitate a Channel move (an aggregate of 60 milliseconds) during the remainder of the 10 seconds period. The aggregate duration of control signals will not count quiet periods in between transmissions.

Test Site	SIP-TR2	Test Engineer	Alisa Deng
Test Date	2023-03-20		
Test Item	Channel Move Time and Channel Closing Transmission Time (802.11ax-HE80 mode - 5530MHz)		
Test Mode	Mode 2		

Channel Move Time and Channel Closing Transmission Time

Parameter	Test Result	Limit
Channel Move Time (s)	0.2595s	<10s
Channel Closing Transmission Time (ms) (Note)	7.5ms	< 60ms

Note: The Channel Closing Transmission Time is comprised of 200 milliseconds starting at the beginning of the Channel Move Time plus any additional intermittent control signals required to facilitate a Channel move (an aggregate of 60 milliseconds) during the remainder of the 10 seconds period. The aggregate duration of control signals will not count quiet periods in between transmissions.

A.8 Statistical Performance Check

Test Site	SIP-TR2	Test Engineer	Alisa Deng
Test Date	2023-03-26		
Test Item	Radar Statistical Performance Check (802.11ax-HE20 – 5500MHz)		

Radar Type 1-4 - Radar Statistical Performance								
Trial	Radar Type 1		Radar Type 2		Radar Type 3		Radar Type 4	
	Frequency (MHz)	1=detect 0=no detect	Frequency (MHz)	1=detect 0=no detect	Frequency (MHz)	1=detect 0=no detect	Frequency (MHz)	1=detect 0=no detect
0	5510	1	5507	1	5494	1	5500	1
1	5499	1	5508	1	5490	0	5497	1
2	5492	1	5497	1	5507	1	5505	1
3	5503	1	5503	1	5493	1	5506	1
4	5494	1	5507	1	5497	1	5494	1
5	5499	1	5503	1	5508	0	5492	1
6	5505	1	5498	1	5507	1	5501	1
7	5496	1	5491	1	5493	1	5493	1
8	5491	1	5510	1	5510	1	5500	1
9	5506	1	5509	1	5503	1	5506	1
10	5510	1	5491	1	5494	1	5490	0
11	5494	1	5492	1	5503	1	5500	1
12	5496	1	5496	1	5494	1	5490	0
13	5496	1	5497	1	5490	0	5505	1
14	5501	1	5504	0	5498	1	5508	1
15	5503	1	5503	1	5500	1	5499	1
16	5492	1	5506	1	5503	0	5501	1
17	5508	1	5510	1	5497	1	5505	1
18	5505	1	5509	1	5492	1	5496	1
19	5496	1	5495	1	5505	1	5503	1
20	5501	1	5490	0	5506	1	5510	0
21	5496	1	5492	1	5502	1	5507	1
22	5492	1	5503	1	5490	0	5496	1
23	5501	1	5495	1	5495	1	5510	0
24	5490	1	5490	0	5500	1	5507	1
25	5508	1	5510	1	5496	1	5490	0
26	5492	1	5493	1	5494	1	5510	0

Radar Type 1-4 - Radar Statistical Performance								
Trial	Radar Type 1		Radar Type 2		Radar Type 3		Radar Type 4	
	Frequency (MHz)	1=detect 0=no detect	Frequency (MHz)	1=detect 0=no detect	Frequency (MHz)	1=detect 0=no detect	Frequency (MHz)	1=detect 0=no detect
27	5505	1	5500	1	5500	1	5508	1
28	5491	1	5496	1	5501	1	5495	1
29	5500	0	5505	0	5497	1	5492	0
Probability:	96.7%		86.7%		83.3%		76.7%	
Aggregate:	85.85% (>80%)							

Radar Type 1 - Radar Waveform							Radar Type 2 - Radar Waveform						
Trial List							Trial List						
	Trial Id	Radar Type	Pulse Width (us)	PRI (us)	Number of Pulses	Waveform Length (us)		Trial Id	Radar Type	Pulse Width (us)	PRI (us)	Number of Pulses	Waveform Length (us)
Download	0	Type 1	1.0	658.0	81	53298.0	Download	0	Type 2	1.2	182.0	23	4186.0
Download	1	Type 1	1.0	738.0	72	53136.0	Download	1	Type 2	2.7	201.0	25	5025.0
Download	2	Type 1	1.0	518.0	102	52636.0	Download	2	Type 2	2.5	173.0	25	4325.0
Download	3	Type 1	1.0	858.0	62	53196.0	Download	3	Type 2	4.8	215.0	29	6235.0
Download	4	Type 1	1.0	938.0	57	53466.0	Download	4	Type 2	2.9	202.0	26	5252.0
Download	5	Type 1	1.0	698.0	76	53048.0	Download	5	Type 2	4.8	161.0	29	4669.0
Download	6	Type 1	1.0	538.0	99	53262.0	Download	6	Type 2	4.9	157.0	29	4553.0
Download	7	Type 1	1.0	678.0	78	52884.0	Download	7	Type 2	4.0	203.0	28	5684.0
Download	8	Type 1	1.0	578.0	92	53176.0	Download	8	Type 2	4.2	225.0	28	6300.0
Download	9	Type 1	1.0	798.0	67	53466.0	Download	9	Type 2	4.1	191.0	28	5348.0
Download	10	Type 1	1.0	898.0	59	52982.0	Download	10	Type 2	3.4	155.0	27	4185.0
Download	11	Type 1	1.0	598.0	89	53222.0	Download	11	Type 2	4.1	168.0	28	4704.0
Download	12	Type 1	1.0	638.0	83	52954.0	Download	12	Type 2	1.3	171.0	23	3933.0
Download	13	Type 1	1.0	778.0	68	52904.0	Download	13	Type 2	1.5	185.0	23	4255.0
Download	14	Type 1	1.0	838.0	63	52794.0	Download	14	Type 2	2.6	167.0	25	4175.0
Download	15	Type 1	1.0	2455.0	22	54010.0	Download	15	Type 2	2.5	163.0	25	4075.0
Download	16	Type 1	1.0	715.0	74	52910.0	Download	16	Type 2	2.9	184.0	26	4784.0
Download	17	Type 1	1.0	2035.0	26	52910.0	Download	17	Type 2	1.8	179.0	24	4296.0
Download	18	Type 1	1.0	1567.0	34	53278.0	Download	18	Type 2	4.5	223.0	29	6467.0
Download	19	Type 1	1.0	971.0	55	53405.0	Download	19	Type 2	1.0	170.0	23	3910.0
Download	20	Type 1	1.0	2354.0	23	54142.0	Download	20	Type 2	5.0	199.0	29	5771.0
Download	21	Type 1	1.0	522.0	102	53244.0	Download	21	Type 2	3.2	224.0	26	5824.0
Download	22	Type 1	1.0	623.0	85	52955.0	Download	22	Type 2	4.4	150.0	28	4200.0
Download	23	Type 1	1.0	1429.0	37	52873.0	Download	23	Type 2	4.5	190.0	28	5320.0
Download	24	Type 1	1.0	1862.0	29	53998.0	Download	24	Type 2	4.6	180.0	29	5220.0
Download	25	Type 1	1.0	1894.0	28	53032.0	Download	25	Type 2	1.5	187.0	23	4301.0
Download	26	Type 1	1.0	2756.0	20	55120.0	Download	26	Type 2	2.0	154.0	24	3696.0
Download	27	Type 1	1.0	2345.0	23	53935.0	Download	27	Type 2	5.0	193.0	29	5597.0
Download	28	Type 1	1.0	1569.0	34	53346.0	Download	28	Type 2	2.7	188.0	26	4888.0
Download	29	Type 1	1.0	2592.0	21	54432.0	Download	29	Type 2	2.5	152.0	25	3800.0



Radar Type 3 - Radar Waveform							Radar Type 4 - Radar Waveform						
Trial List							Trial List						
	Trial Id	Radar Type	Pulse Width (us)	PRI (us)	Number of Pulses	Waveform Length (us)		Trial Id	Radar Type	Pulse Width (us)	PRI (us)	Number of Pulses	Waveform Length (us)
Download	0	Type 3	6.2	302.0	16	4832.0	Download	0	Type 4	11.4	302.0	12	3624.0
Download	1	Type 3	7.7	210.0	17	3570.0	Download	1	Type 4	14.8	210.0	14	2940.0
Download	2	Type 3	7.5	252.0	17	4284.0	Download	2	Type 4	14.3	252.0	13	3276.0
Download	3	Type 3	9.8	468.0	18	8424.0	Download	3	Type 4	19.4	468.0	16	7488.0
Download	4	Type 3	7.9	214.0	17	3638.0	Download	4	Type 4	15.4	214.0	14	2996.0
Download	5	Type 3	9.8	422.0	18	7596.0	Download	5	Type 4	19.4	422.0	16	6752.0
Download	6	Type 3	9.9	417.0	18	7506.0	Download	6	Type 4	19.7	417.0	16	6672.0
Download	7	Type 3	9.0	280.0	18	5040.0	Download	7	Type 4	17.8	280.0	15	4200.0
Download	8	Type 3	9.2	271.0	18	4878.0	Download	8	Type 4	18.2	271.0	15	4065.0
Download	9	Type 3	9.1	451.0	18	8118.0	Download	9	Type 4	18.0	451.0	15	6765.0
Download	10	Type 3	8.4	351.0	17	5967.0	Download	10	Type 4	16.4	351.0	14	4914.0
Download	11	Type 3	9.1	429.0	18	7722.0	Download	11	Type 4	18.0	429.0	15	6435.0
Download	12	Type 3	8.3	270.0	16	4320.0	Download	12	Type 4	11.7	270.0	12	3240.0
Download	13	Type 3	6.5	315.0	16	5040.0	Download	13	Type 4	12.2	315.0	12	3780.0
Download	14	Type 3	7.6	303.0	17	5151.0	Download	14	Type 4	14.6	303.0	14	4242.0
Download	15	Type 3	7.5	471.0	17	8007.0	Download	15	Type 4	14.3	471.0	13	6123.0
Download	16	Type 3	7.9	262.0	17	4454.0	Download	16	Type 4	15.2	262.0	14	3668.0
Download	17	Type 3	6.8	305.0	16	4880.0	Download	17	Type 4	12.8	305.0	13	3965.0
Download	18	Type 3	9.5	336.0	18	6048.0	Download	18	Type 4	18.8	336.0	16	5376.0
Download	19	Type 3	6.0	401.0	16	6416.0	Download	19	Type 4	11.0	401.0	12	4812.0
Download	20	Type 3	10.0	457.0	18	8226.0	Download	20	Type 4	20.0	457.0	16	7312.0
Download	21	Type 3	8.2	475.0	17	8075.0	Download	21	Type 4	16.0	475.0	14	6650.0
Download	22	Type 3	9.4	290.0	18	5220.0	Download	22	Type 4	18.5	290.0	16	4640.0
Download	23	Type 3	9.5	215.0	18	3870.0	Download	23	Type 4	18.7	215.0	16	3440.0
Download	24	Type 3	9.6	207.0	18	3726.0	Download	24	Type 4	19.1	207.0	16	3312.0
Download	25	Type 3	6.5	412.0	16	6592.0	Download	25	Type 4	12.2	412.0	12	4944.0
Download	26	Type 3	7.0	419.0	16	6704.0	Download	26	Type 4	13.2	419.0	13	5447.0
Download	27	Type 3	10.0	208.0	18	3744.0	Download	27	Type 4	20.0	208.0	16	3328.0
Download	28	Type 3	7.7	354.0	17	6018.0	Download	28	Type 4	14.9	354.0	14	4956.0
Download	29	Type 3	7.5	330.0	17	5610.0	Download	29	Type 4	14.4	330.0	13	4290.0

Radar Type 5 - Radar Statistical Performance					
Trail #	Test Freq. (MHz)	1=Detection 0=No Detection	Trail #	Test Freq. (MHz)	1=Detection 0=No Detection
0	5500	1	15	5494	1
1	5500	1	16	5495	1
2	5500	1	17	5494	1
3	5500	1	18	5498	1
4	5500	1	19	5492	0
5	5500	1	20	5502	1
6	5500	1	21	5504	1
7	5500	1	22	5502	1
8	5500	1	23	5502	1
9	5500	1	24	5502	1
10	5496	1	25	5507	1
11	5497	1	26	5506	1
12	5493	1	27	5502	1
13	5493	1	28	5505	1
14	5495	1	29	5505	1
Detection Percentage (%)			96.7%		

Type 5 Radar Waveform_0

Download	0	Type 5	8	1.5000000	12.0000000	5.500000000				
		Burst ID	Burst Offset (us)	Pulse Width (us)	Chirp Width (MHz)	Number of Pulses per Burst	PRI-1 (us)	PRI-2 (us)	PRI-3 (us)	
		0	443341.0	52.6	5	1	1398.0	-	-	
		1	805475.0	71.4	5	2	1882.0	1974.0	-	
		2	1169013.0	68.3	5	2	1926.0	1064.0	-	
		3	35054.0	96.6	5	3	1344.0	1115.0	1446.0	
		4	398161.0	74.3	5	2	1711.0	1227.0	-	
		5	760570.0	96.7	5	3	1263.0	1039.0	1966.0	
		6	1123440.0	98.0	5	3	1479.0	1287.0	1357.0	
		7	1486449.0	87.7	5	3	1112.0	1121.0	1678.0	

Type 5 Radar Waveform_1

Download	1	Type 5	13	0.9230769	12.0000000	5.500000000				
		Burst ID	Burst Offset (us)	Pulse Width (us)	Chirp Width (MHz)	Number of Pulses per Burst	PRI-1 (us)	PRI-2 (us)	PRI-3 (us)	
		0	216878.0	89.7	11	3	1209.0	1853.0	1383.0	
		1	440111.0	88.9	11	3	1178.0	1017.0	1339.0	
		2	663347.0	80.0	11	2	1337.0	1894.0	-	
		3	885410.0	88.9	11	3	1475.0	1778.0	1046.0	
		4	190033.0	54.0	11	1	1542.0	-	-	
		5	413576.0	56.8	11	1	1449.0	-	-	
		6	636017.0	70.1	11	2	1443.0	1571.0	-	
		7	859322.0	68.7	11	2	1514.0	1328.0	-	
		8	162086.0	73.3	11	2	1969.0	1937.0	-	
		9	386140.0	60.4	11	1	1217.0	-	-	
		10	608410.0	93.4	11	3	1113.0	1021.0	1063.0	
		11	833352.0	50.3	11	1	1159.0	-	-	
		12	134460.0	99.9	11	3	1709.0	1426.0	1905.0	

Type 5 Radar Waveform_2

Download	2	Type 5	12	1.0000000	12.0000000	5.500000000				
		Burst ID	Burst Offset (us)	Pulse Width (us)	Chirp Width (MHz)	Number of Pulses per Burst	PRI-1 (us)	PRI-2 (us)	PRI-3 (us)	
		0	388070.0	77.7	10	2	1220.0	1161.0	-	
		1	628497.0	91.6	10	3	1818.0	1609.0	1372.0	
		2	870705.0	92.7	10	3	1160.0	1102.0	1575.0	
		3	116073.0	94.8	10	3	1268.0	1957.0	1208.0	
		4	358552.0	56.8	10	1	1587.0	-	-	
		5	600613.0	62.4	10	1	1729.0	-	-	
		6	839949.0	99.8	10	3	1452.0	1895.0	1670.0	
		7	96403.0	71.4	10	2	1665.0	1940.0	-	
		8	328040.0	68.7	10	2	1816.0	1851.0	-	
		9	569019.0	97.6	10	3	1648.0	1218.0	1961.0	
		10	812281.0	75.8	10	2	1347.0	1145.0	-	
		11	56600.0	94.9	10	3	1439.0	1461.0	1349.0	

Type 5 Radar Waveform_3

Download	3	Type 5	20	0.6000000	12.0000000	5.500000000				
		Burst ID	Burst Offset (us)	Pulse Width (us)	Chirp Width (MHz)	Number of Pulses per Burst	PRI-1 (us)	PRI-2 (us)	PRI-3 (us)	
		0	179076.0	60.9	19	1	1832.0	-	-	
		1	323028.0	89.8	19	3	1573.0	1019.0	1310.0	
		2	469159.0	66.0	19	1	1915.0	-	-	
		3	16054.0	89.3	19	3	1434.0	1927.0	1314.0	
		4	160715.0	71.0	19	2	1962.0	1692.0	-	
		5	305959.0	80.4	19	2	1170.0	1289.0	-	
		6	451725.0	60.0	19	1	1341.0	-	-	
		7	594147.0	94.0	19	3	1249.0	1246.0	1626.0	
		8	142947.0	83.8	19	3	1055.0	1382.0	1018.0	
		9	287256.0	85.8	19	3	1473.0	1353.0	1400.0	
		10	431324.0	88.2	19	3	1474.0	1830.0	1510.0	
		11	579362.0	62.4	19	1	1002.0	-	-	
		12	125236.0	73.1	19	2	1202.0	1724.0	-	
		13	270707.0	54.3	19	1	1464.0	-	-	
		14	413487.0	91.0	19	3	1186.0	1954.0	1755.0	
		15	560771.0	61.4	19	1	1745.0	-	-	
		16	107226.0	70.2	19	2	1950.0	1938.0	-	
		17	251766.0	99.9	19	3	1151.0	1295.0	1527.0	
		18	397912.0	58.0	19	1	1581.0	-	-	
		19	541138.0	69.3	19	2	1710.0	1975.0	-	

Type 5 Radar Waveform_4

Download	4	Type 5	14	0.8571429	12.0000000	5.500000000				
		Burst ID	Burst Offset (us)	Pulse Width (us)	Chirp Width (MHz)	Number of Pulses per Burst	PRI-1 (us)	PRI-2 (us)	PRI-3 (us)	
		0	127830.0	94.4	12	3	1770.0	1780.0	1399.0	
		1	334927.0	94.4	12	3	1588.0	1292.0	1016.0	
		2	542842.0	75.0	12	2	1231.0	1129.0	-	
		3	749676.0	79.9	12	2	1732.0	1173.0	-	
		4	102580.0	75.7	12	2	1800.0	1417.0	-	
		5	310365.0	51.8	12	1	1338.0	-	-	
		6	517310.0	67.4	12	2	1177.0	1176.0	-	
		7	722415.0	84.3	12	3	1491.0	1481.0	1986.0	
		8	76914.0	98.3	12	3	1590.0	1841.0	1606.0	
		9	284727.0	66.3	12	1	1551.0	-	-	
		10	491490.0	70.9	12	2	1690.0	1157.0	-	
		11	697492.0	91.4	12	3	1166.0	1493.0	1645.0	
		12	51667.0	54.1	12	1	1427.0	-	-	
		13	258293.0	94.1	12	3	1706.0	1368.0	1364.0	

Type 5 Radar Waveform_5

Download	5	Type 5	20	0.6000000	12.0000000	5.500000000				
		Burst ID	Burst Offset (us)	Pulse Width (us)	Chirp Width (MHz)	Number of Pulses per Burst	PRI-1 (us)	PRI-2 (us)	PRI-3 (us)	
		0	324903.0	93.2	19	3	1030.0	1869.0	1432.0	
		1	470452.0	67.1	19	2	1448.0	1511.0	-	
		2	18264.0	54.0	19	1	1266.0	-	-	
		3	163026.0	79.4	19	2	1777.0	1138.0	-	
		4	308445.0	52.2	19	1	1736.0	-	-	
		5	452423.0	80.0	19	2	1842.0	1371.0	-	
		6	375.0	83.4	19	3	1604.0	1722.0	1219.0	
		7	145472.0	56.4	19	1	1747.0	-	-	
		8	290912.0	66.1	19	1	1037.0	-	-	
		9	433631.0	92.0	19	3	1190.0	1671.0	1676.0	
		10	580609.0	53.3	19	1	1900.0	-	-	
		11	127343.0	80.2	19	2	1388.0	1561.0	-	
		12	272342.0	71.6	19	2	1318.0	1203.0	-	
		13	417969.0	52.4	19	1	1490.0	-	-	
		14	561861.0	71.5	19	2	1087.0	1748.0	-	
		15	109336.0	88.4	19	3	1049.0	1767.0	1066.0	
		16	255078.0	51.2	19	1	1146.0	-	-	
		17	399207.0	68.9	19	2	1498.0	1312.0	-	
		18	543512.0	89.5	19	3	1033.0	1029.0	1332.0	
		19	91898.0	56.5	19	1	1468.0	-	-	

Type 5 Radar Waveform_6

Download	6	Type 5	20	0.6000000	12.0000000	5.500000000				
		Burst ID	Burst Offset (us)	Pulse Width (us)	Chirp Width (MHz)	Number of Pulses per Burst	PRI-1 (us)	PRI-2 (us)	PRI-3 (us)	
		0	236939.0	50.5	20	1	1776.0	-	-	
		1	380814.0	76.6	20	2	1805.0	1870.0	-	
		2	527096.0	64.7	20	1	1797.0	-	-	
		3	73705.0	86.1	20	3	1142.0	1172.0	1679.0	
		4	219009.0	63.6	20	1	1935.0	-	-	
		5	363349.0	69.2	20	2	1669.0	1431.0	-	
		6	509134.0	62.9	20	1	1904.0	-	-	
		7	56009.0	75.8	20	2	1471.0	1356.0	-	
		8	200310.0	95.7	20	3	1971.0	1297.0	1140.0	
		9	345559.0	67.5	20	2	1892.0	1136.0	-	
		10	491777.0	64.8	20	1	1282.0	-	-	
		11	38058.0	96.8	20	3	1793.0	1687.0	1075.0	
		12	163391.0	58.3	20	1	1558.0	-	-	
		13	327635.0	79.0	20	2	1477.0	1714.0	-	
		14	474108.0	61.1	20	1	1008.0	-	-	
		15	20337.0	73.8	20	2	1111.0	1456.0	-	
		16	165486.0	57.3	20	1	1655.0	-	-	
		17	309285.0	90.8	20	3	1153.0	1348.0	1693.0	
		18	453009.0	97.6	20	3	1863.0	1880.0	1873.0	
		19	2486.0	78.0	20	2	1865.0	1597.0	-	

Type 5 Radar Waveform_7

Download	7	Type 5	17	0.7058824	12.0000000	5.500000000				
		Burst ID	Burst Offset (us)	Pulse Width (us)	Chirp Width (MHz)	Number of Pulses per Burst	PRI-1 (us)	PRI-2 (us)	PRI-3 (us)	
		0	173070.0	86.0	17	3	1792.0	1529.0	1015.0	
		1	343271.0	87.9	17	3	1392.0	1773.0	1061.0	
		2	514340.0	68.2	17	2	1012.0	1991.0	-	
		3	684887.0	83.1	17	2	1492.0	1433.0	-	
		4	152458.0	76.5	17	2	1519.0	1221.0	-	
		5	321845.0	95.5	17	3	1914.0	1701.0	1623.0	
		6	493143.0	80.2	17	2	1585.0	1702.0	-	
		7	665356.0	65.0	17	1	1369.0	-	-	
		8	131684.0	62.7	17	1	1500.0	-	-	
		9	302703.0	59.9	17	1	1071.0	-	-	
		10	473675.0	65.0	17	1	1022.0	-	-	
		11	644449.0	51.9	17	1	1216.0	-	-	
		12	110709.0	51.9	17	1	1067.0	-	-	
		13	280039.0	97.7	17	3	1212.0	1963.0	1921.0	
		14	450206.0	93.6	17	3	1821.0	1618.0	1340.0	
		15	623479.0	66.6	17	1	1124.0	-	-	
		16	89586.0	52.4	17	1	1594.0	-	-	

Type 5 Radar Waveform_8

Download	8	Type 5	18	0.6666667	12.0000000	5.500000000				
		Burst ID	Burst Offset (us)	Pulse Width (us)	Chirp Width (MHz)	Number of Pulses per Burst	PRI-1 (us)	PRI-2 (us)	PRI-3 (us)	
		0	245380.0	68.0	17	2	1408.0	1589.0	-	
		1	406965.0	65.8	17	1	1978.0	-	-	
		2	567142.0	83.1	17	2	1647.0	1537.0	-	
		3	64590.0	67.0	17	2	1883.0	1144.0	-	
		4	225944.0	57.5	17	1	1847.0	-	-	
		5	387355.0	60.7	17	1	1553.0	-	-	
		6	546604.0	98.6	17	3	1032.0	1336.0	1685.0	
		7	44779.0	77.1	17	2	1276.0	1526.0	-	
		8	206181.0	56.6	17	1	1531.0	-	-	
		9	366644.0	71.9	17	2	1901.0	1175.0	-	
		10	526711.0	92.7	17	3	1253.0	1374.0	1549.0	
		11	24911.0	91.4	17	3	1233.0	1224.0	1301.0	
		12	185434.0	97.7	17	3	1085.0	1872.0	1703.0	
		13	346596.0	81.1	17	2	1880.0	1624.0	-	
		14	508955.0	60.5	17	1	1516.0	-	-	
		15	5119.0	71.4	17	2	1048.0	1182.0	-	
		16	166363.0	61.5	17	1	1838.0	-	-	
		17	327153.0	70.5	17	2	1042.0	1715.0	-	

Type 5 Radar Waveform_9

Download	9	Type 5	18	0.6666667	12.0000000	5.500000000				
		Burst ID	Burst Offset (us)	Pulse Width (us)	Chirp Width (MHz)	Number of Pulses per Burst	PRI-1 (us)	PRI-2 (us)	PRI-3 (us)	
		0	489188.0	62.6	17	1	1375.0	-	-	
		1	850574.0	58.3	17	1	1342.0	-	-	
		2	146316.0	81.7	17	2	1555.0	1130.0	-	
		3	308107.0	59.6	17	1	1054.0	-	-	
		4	468294.0	68.1	17	2	1813.0	1006.0	-	
		5	627862.0	89.0	17	3	1370.0	1772.0	1192.0	
		6	126114.0	98.0	17	3	1472.0	1320.0	1610.0	
		7	288121.0	63.0	17	1	1288.0	-	-	
		8	447434.0	85.8	17	3	1874.0	1076.0	1391.0	
		9	610728.0	52.4	17	1	1444.0	-	-	
		10	106768.0	62.8	17	1	1909.0	-	-	
		11	266896.0	94.9	17	3	1414.0	1554.0	1661.0	
		12	429203.0	60.7	17	1	1931.0	-	-	
		13	588629.0	85.5	17	3	1211.0	1533.0	1207.0	
		14	86464.0	94.6	17	3	1419.0	1967.0	1924.0	
		15	247812.0	71.4	17	2	1171.0	1599.0	-	
		16	407834.0	89.4	17	3	1808.0	1497.0	1079.0	
		17	569787.0	74.9	17	2	1503.0	1333.0	-	

Type 5 Radar Waveform_10

Download	10	Type 5	15	0.8000000	12.0000000	5.496000000				
		Burst ID	Burst Offset (us)	Pulse Width (us)	Chirp Width (MHz)	Number of Pulses per Burst	PRI-1 (us)	PRI-2 (us)	PRI-3 (us)	
		0	80579.0	64.4	14	1	1108.0	--	--	
		1	274328.0	60.9	14	1	1128.0	--	--	
		2	466880.0	78.4	14	2	1627.0	1550.0	--	
		3	660530.0	77.2	14	2	1305.0	1394.0	--	
		4	56606.0	69.7	14	2	1223.0	1389.0	--	
		5	250260.0	55.9	14	1	1774.0	--	--	
		6	443119.0	69.9	14	2	1659.0	1440.0	--	
		7	636528.0	73.6	14	2	1412.0	1518.0	--	
		8	32720.0	87.6	14	3	1154.0	1877.0	1139.0	
		9	226239.0	73.7	14	2	1117.0	1275.0	--	
		10	420274.0	65.0	14	1	1270.0	--	--	
		11	613005.0	78.9	14	2	1147.0	1406.0	--	
		12	8973.0	54.5	14	1	1733.0	--	--	
		13	202247.0	80.6	14	2	1306.0	1730.0	--	
		14	394425.0	90.4	14	3	1465.0	1833.0	1977.0	

Type 5 Radar Waveform_11

Download	11	Type 5	18	0.6666667	12.0000000	5.497000000				
		Burst ID	Burst Offset (us)	Pulse Width (us)	Chirp Width (MHz)	Number of Pulses per Burst	PRI-1 (us)	PRI-2 (us)	PRI-3 (us)	
		0	490580.0	77.1	17	2	1634.0	1041.0	--	
		1	651476.0	81.0	17	2	1309.0	1512.0	--	
		2	148923.0	58.3	17	1	1530.0	--	--	
		3	309710.0	70.7	17	2	1201.0	1463.0	--	
		4	471639.0	58.3	17	1	1413.0	--	--	
		5	630082.0	97.8	17	3	1725.0	1422.0	1316.0	
		6	126584.0	94.2	17	3	1174.0	1250.0	1520.0	
		7	289640.0	69.1	17	2	1612.0	1586.0	--	
		8	449324.0	94.6	17	3	1408.0	1897.0	1622.0	
		9	611993.0	75.0	17	2	1090.0	1535.0	--	
		10	108707.0	96.2	17	3	1756.0	1574.0	1088.0	
		11	270512.0	64.3	17	1	1495.0	--	--	
		12	431697.0	61.7	17	1	1712.0	--	--	
		13	593215.0	61.1	17	1	1436.0	--	--	
		14	89356.0	57.2	17	1	1194.0	--	--	
		15	249716.0	96.8	17	3	1089.0	1644.0	1215.0	
		16	410706.0	76.3	17	2	1611.0	1918.0	--	
		17	571478.0	91.7	17	3	1065.0	1110.0	1424.0	

Type 5 Radar Waveform_12

Download	12	Type 5	9	1.3333333	12.0000000	5.493000000				
		Burst ID	Burst Offset (us)	Pulse Width (us)	Chirp Width (MHz)	Number of Pulses per Burst	PRI-1 (us)	PRI-2 (us)	PRI-3 (us)	
		0	138746.0	85.6	6	3	1196.0	1343.0	1812.0	
		1	462059.0	56.9	6	1	1489.0	--	--	
		2	785345.0	50.5	6	1	1027.0	--	--	
		3	1105205.0	92.1	6	3	1758.0	1442.0	1753.0	
		4	98957.0	85.5	6	3	1979.0	1784.0	1740.0	
		5	421247.0	88.7	6	3	1155.0	1656.0	1906.0	
		6	744579.0	75.7	6	2	1083.0	1668.0	--	
		7	1065071.0	89.7	6	3	1666.0	1898.0	1949.0	
		8	59312.0	94.6	6	3	1860.0	1225.0	1908.0	

Type 5 Radar Waveform_13

Download	13	Type 5	9	1.3333333	12.0000000	5.493000000				
		Burst ID	Burst Offset (us)	Pulse Width (us)	Chirp Width (MHz)	Number of Pulses per Burst	PRI-1 (us)	PRI-2 (us)	PRI-3 (us)	
		0	382368.0	51.4	7	1	1888.0	--	--	
		1	704673.0	74.3	7	2	1876.0	1169.0	--	
		2	1026446.0	98.0	7	3	1210.0	1567.0	1386.0	
		3	19678.0	56.8	7	1	1642.0	--	--	
		4	341986.0	98.0	7	3	1835.0	1007.0	1401.0	
		5	664672.0	82.2	7	2	1878.0	1686.0	--	
		6	988792.0	54.4	7	1	1396.0	--	--	
		7	1309162.0	83.6	7	3	1345.0	1579.0	1180.0	
		8	302856.0	54.4	7	1	1713.0	--	--	

Type 5 Radar Waveform_14

Download	14	Type 5	13	0.9230769	12.0000000	5.495000000				
		Burst ID	Burst Offset (us)	Pulse Width (us)	Chirp Width (MHz)	Number of Pulses per Burst	PRI-1 (us)	PRI-2 (us)	PRI-3 (us)	
		0	431447.0	86.3	11	3	1727.0	1750.0	1560.0	
		1	656428.0	50.6	11	1	1771.0	--	--	
		2	679268.0	81.0	11	2	1379.0	1026.0	--	
		3	181792.0	77.2	11	2	1630.0	1261.0	--	
		4	404648.0	70.3	11	2	1886.0	1726.0	--	
		5	627624.0	91.9	11	3	1485.0	1000.0	1162.0	
		6	849686.0	83.9	11	3	1293.0	1864.0	1494.0	
		7	154485.0	52.1	11	1	1796.0	--	--	
		8	377413.0	73.6	11	2	1761.0	1263.0	--	
		9	599312.0	91.7	11	3	1459.0	1675.0	1807.0	
		10	825353.0	58.1	11	1	1183.0	--	--	
		11	127013.0	62.4	11	1	1429.0	--	--	
		12	349893.0	80.4	11	2	1754.0	1381.0	--	

Type 5 Radar Waveform_15

Download	15	Type 5	12	1.0000000	12.0000000	5.494000000				
		Burst ID	Burst Offset (us)	Pulse Width (us)	Chirp Width (MHz)	Number of Pulses per Burst	PRI-1 (us)	PRI-2 (us)	PRI-3 (us)	
		0	621381.0	76.9	10	2	1126.0	1271.0	--	
		1	861450.0	88.8	10	3	1313.0	1779.0	1478.0	
		2	107419.0	87.2	10	3	1640.0	1200.0	1959.0	
		3	349159.0	68.9	10	2	1903.0	1834.0	--	
		4	591193.0	73.6	10	2	1546.0	1501.0	--	
		5	832333.0	89.8	10	3	1187.0	1617.0	1023.0	
		6	77687.0	85.1	10	3	1593.0	1232.0	1984.0	
		7	318789.0	95.6	10	3	1829.0	1836.0	1965.0	
		8	561173.0	69.6	10	2	1707.0	1760.0	--	
		9	802107.0	95.0	10	3	1242.0	1598.0	1566.0	
		10	48060.0	68.6	10	2	1050.0	1613.0	--	
		11	290288.0	53.1	10	1	1486.0	--	--	

Type 5 Radar Waveform_16

Download	16	Type 5	14	0.8571429	12.0000000	5.495000000				
		Burst ID	Burst Offset (us)	Pulse Width (us)	Chirp Width (MHz)	Number of Pulses per Burst	PRI-1 (us)	PRI-2 (us)	PRI-3 (us)	
		0	454727.0	92.7	12	3	1569.0	1522.0	1307.0	
		1	661456.0	94.8	12	3	1864.0	1047.0	1801.0	
		2	15590.0	96.7	12	3	1944.0	1970.0	1956.0	
		3	222750.0	68.1	12	2	1248.0	1939.0	--	
		4	428928.0	98.2	12	3	1327.0	1742.0	1973.0	
		5	636739.0	82.1	12	2	1958.0	1543.0	--	
		6	845835.0	57.3	12	1	1415.0	--	--	
		7	197388.0	77.5	12	2	1038.0	1504.0	--	
		8	405056.0	52.7	12	1	1696.0	--	--	
		9	612467.0	60.5	12	1	1783.0	--	--	
		10	818720.0	75.6	12	2	1453.0	1580.0	--	
		11	172074.0	60.7	12	1	1466.0	--	--	
		12	379595.0	58.4	12	1	1482.0	--	--	
		13	584827.0	86.7	12	3	1366.0	1856.0	1601.0	

Type 5 Radar Waveform_17

Download	17	Type 5	10	1.2000000	12.0000000	5.494000000				
		Burst ID	Burst Offset (us)	Pulse Width (us)	Chirp Width (MHz)	Number of Pulses per Burst	PRI-1 (us)	PRI-2 (us)	PRI-3 (us)	
		0	1113221.0	58.7	8	1	1302.0	--	--	
		1	205124.0	58.2	8	1	2000.0	--	--	
		2	495459.0	83.3	8	2	1322.0	1205.0	--	
		3	786388.0	65.1	8	1	1759.0	--	--	
		4	1075244.0	84.1	8	3	1469.0	1020.0	1222.0	
		5	169058.0	81.6	8	2	1976.0	1982.0	--	
		6	459692.0	82.2	8	2	1127.0	1643.0	--	
		7	750012.0	71.0	8	2	1385.0	1298.0	--	
		8	1039423.0	97.5	8	3	1258.0	1119.0	1430.0	
		9	133600.0	59.2	8	1	1507.0	--	--	

Type 5 Radar Waveform_18

Download	18	Type 5	19	0.6315789	12.0000000	5.498000000				
		Burst ID	Burst Offset (us)	Pulse Width (us)	Chirp Width (MHz)	Number of Pulses per Burst	PRI-1 (us)	PRI-2 (us)	PRI-3 (us)	
		0	222298.0	69.7	18	2	1738.0	1890.0	-	
		1	375133.0	79.0	18	2	1165.0	1562.0	-	
		2	528572.0	58.6	18	1	1628.0	-	-	
		3	51439.0	64.7	18	1	1197.0	-	-	
		4	203125.0	98.6	18	3	1244.0	1677.0	1981.0	
		5	357021.0	58.9	18	1	1538.0	-	-	
		6	509592.0	66.6	18	1	1826.0	-	-	
		7	32598.0	55.6	18	1	1362.0	-	-	
		8	185471.0	62.3	18	1	1277.0	-	-	
		9	337471.0	74.0	18	2	1565.0	1329.0	-	
		10	489271.0	77.6	18	2	1768.0	1993.0	-	
		11	13720.0	97.1	18	3	1470.0	1106.0	1105.0	
		12	165707.0	87.2	18	3	1996.0	1230.0	1583.0	
		13	317848.0	84.0	18	3	1827.0	1044.0	1682.0	
		14	471229.0	75.4	18	2	1505.0	1304.0	-	
		15	625411.0	59.6	18	1	1109.0	-	-	
		16	147726.0	50.8	18	1	1641.0	-	-	
		17	299778.0	84.9	18	3	1068.0	1045.0	1053.0	
		18	452221.0	77.6	18	2	1548.0	1572.0	-	

Type 5 Radar Waveform_19

Download	19	Type 5	8	1.5000000	12.0000000	5.492000000				
		Burst ID	Burst Offset (us)	Pulse Width (us)	Chirp Width (MHz)	Number of Pulses per Burst	PRI-1 (us)	PRI-2 (us)	PRI-3 (us)	
		0	1441554.0	66.4	5	1	1662.0	-	-	
		1	306572.0	63.1	5	1	1849.0	-	-	
		2	669102.0	76.4	5	2	1945.0	1735.0	-	
		3	1033690.0	60.5	5	1	1239.0	-	-	
		4	1394681.0	87.0	5	3	1285.0	1058.0	1584.0	
		5	261627.0	81.1	5	2	1135.0	1790.0	-	
		6	624583.0	76.8	5	2	1987.0	1254.0	-	
		7	988734.0	62.2	5	1	1513.0	-	-	

Type 5 Radar Waveform_20

Download	20	Type 5	20	0.6000000	12.0000000	5.502000000				
		Burst ID	Burst Offset (us)	Pulse Width (us)	Chirp Width (MHz)	Number of Pulses per Burst	PRI-1 (us)	PRI-2 (us)	PRI-3 (us)	
		0	539880.0	54.5	20	1	1698.0	-	-	
		1	86656.0	60.9	20	1	1899.0	-	-	
		2	230987.0	87.1	20	3	1264.0	1508.0	1003.0	
		3	376161.0	71.0	20	2	1273.0	1596.0	-	
		4	521332.0	71.7	20	2	1390.0	1081.0	-	
		5	68403.0	97.4	20	3	1831.0	1762.0	1854.0	
		6	213053.0	87.5	20	3	1284.0	1299.0	1534.0	
		7	357444.0	98.5	20	3	1787.0	1451.0	1095.0	
		8	503075.0	69.2	20	2	1867.0	1086.0	-	
		9	50812.0	73.4	20	2	1863.0	1311.0	-	
		10	195215.0	92.7	20	3	1652.0	1098.0	1480.0	
		11	340391.0	79.0	20	2	1582.0	1450.0	-	
		12	464346.0	93.8	20	3	1103.0	1131.0	1817.0	
		13	32889.0	93.9	20	3	1204.0	1907.0	1744.0	
		14	177783.0	69.9	20	2	1811.0	1188.0	-	
		15	322238.0	98.5	20	3	1206.0	1163.0	1252.0	
		16	466217.0	84.4	20	3	1091.0	1861.0	1515.0	
		17	15195.0	59.0	20	1	1499.0	-	-	
		18	160391.0	61.6	20	1	1346.0	-	-	
		19	304808.0	71.0	20	2	1764.0	1101.0	-	

Type 5 Radar Waveform_21

Download	21	Type 5	15	0.8000000	12.0000000	5.504000000				
		Burst ID	Burst Offset (us)	Pulse Width (us)	Chirp Width (MHz)	Number of Pulses per Burst	PRI-1 (us)	PRI-2 (us)	PRI-3 (us)	
		0	598757.0	99.4	13	3	1972.0	1788.0	1059.0	
		1	791479.0	89.7	13	3	1559.0	1749.0	1646.0	
		2	189789.0	74.4	13	2	1691.0	1024.0	--	
		3	383351.0	80.8	13	2	1214.0	1097.0	--	
		4	574593.0	97.3	13	3	1859.0	1910.0	1616.0	
		5	767853.0	93.4	13	3	1884.0	1365.0	1576.0	
		6	165939.0	81.1	13	2	1447.0	1423.0	--	
		7	358449.0	96.1	13	3	1502.0	1255.0	1930.0	
		8	550938.0	93.3	13	3	1854.0	1600.0	1809.0	
		9	745867.0	68.4	13	2	1402.0	1532.0	--	
		10	142088.0	71.6	13	2	1080.0	1997.0	--	
		11	334437.0	83.6	13	3	1397.0	1942.0	1947.0	
		12	528378.0	71.8	13	2	1541.0	1941.0	--	
		13	721140.0	96.8	13	3	1191.0	1317.0	1435.0	
		14	118447.0	62.0	13	1	1955.0	--	--	

Type 5 Radar Waveform_22

Download	22	Type 5	16	0.6666667	12.0000000	5.502000000				
		Burst ID	Burst Offset (us)	Pulse Width (us)	Chirp Width (MHz)	Number of Pulses per Burst	PRI-1 (us)	PRI-2 (us)	PRI-3 (us)	
		0	258753.0	94.8	18	3	1705.0	1123.0	1988.0	
		1	420553.0	75.2	18	2	1114.0	1681.0	--	
		2	582899.0	53.0	18	1	1269.0	--	--	
		3	78802.0	55.9	18	1	1936.0	--	--	
		4	238840.0	99.8	18	3	1697.0	1650.0	1857.0	
		5	399263.0	99.8	18	3	1467.0	1752.0	1990.0	
		6	560233.0	85.6	18	3	1943.0	1380.0	1241.0	
		7	58947.0	56.2	18	1	1902.0	--	--	
		8	219152.0	86.2	18	3	1335.0	2000.0	1651.0	
		9	381701.0	58.2	18	1	1376.0	--	--	
		10	542922.0	55.9	18	1	1540.0	--	--	
		11	38889.0	83.9	18	3	1614.0	1946.0	1720.0	
		12	200080.0	72.5	18	2	1674.0	1004.0	--	
		13	360029.0	93.2	18	3	1062.0	1843.0	1775.0	
		14	521475.0	77.9	18	2	1721.0	1823.0	--	
		15	19203.0	76.2	18	2	1496.0	1279.0	--	
		16	180131.0	78.0	18	2	1741.0	1354.0	--	
		17	341077.0	69.4	18	2	1404.0	1673.0	--	

Type 5 Radar Waveform_23

Download	23	Type 5	19	0.6315789	12.0000000	5.502000000				
		Burst ID	Burst Offset (us)	Pulse Width (us)	Chirp Width (MHz)	Number of Pulses per Burst	PRI-1 (us)	PRI-2 (us)	PRI-3 (us)	
		0	476409.0	55.8	18	1	1840.0	--	--	
		1	629378.0	62.9	18	1	1603.0	--	--	
		2	152116.0	64.9	18	1	1913.0	--	--	
		3	303561.0	66.5	18	3	1051.0	1717.0	1766.0	
		4	457727.0	56.2	18	1	1660.0	--	--	
		5	609064.0	73.7	18	2	1319.0	1825.0	--	
		6	133216.0	78.3	18	2	1082.0	1251.0	--	
		7	286357.0	66.2	18	1	1168.0	--	--	
		8	437113.0	91.4	18	3	1116.0	1798.0	1324.0	
		9	591677.0	55.1	18	1	1867.0	--	--	
		10	114535.0	50.7	18	1	1689.0	--	--	
		11	267424.0	51.8	18	1	1403.0	--	--	
		12	420186.0	59.0	18	1	1517.0	--	--	
		13	573165.0	57.2	18	1	1331.0	--	--	
		14	95190.0	97.1	18	3	1743.0	1802.0	1615.0	
		15	247979.0	81.9	18	2	1257.0	1716.0	--	
		16	400171.0	75.2	18	2	1509.0	1879.0	--	
		17	552671.0	73.2	18	2	1934.0	1291.0	--	
		18	76751.0	81.4	18	2	1547.0	1361.0	--	

Type 5 Radar Waveform_24

Download	24	Type 5	19	0.6315789	12.0000000	5.502000000				
		Burst ID	Burst Offset (us)	Pulse Width (us)	Chirp Width (MHz)	Number of Pulses per Burst	PRI-1 (us)	PRI-2 (us)	PRI-3 (us)	
		0	229833.0	53.0	19	1	1235.0	-	-	
		1	382658.0	61.8	19	1	1323.0	-	-	
		2	534461.0	71.2	19	2	1325.0	1238.0	-	
		3	58111.0	63.8	19	1	1373.0	-	-	
		4	209845.0	83.5	19	3	1620.0	1226.0	1846.0	
		5	362190.0	88.2	19	3	1164.0	1998.0	1001.0	
		6	515723.0	72.6	19	2	1148.0	1350.0	-	
		7	39053.0	91.4	19	3	1631.0	1595.0	1855.0	
		8	192095.0	59.5	19	1	1484.0	-	-	
		9	345012.0	58.6	19	1	1303.0	-	-	
		10	497657.0	52.9	19	1	1578.0	-	-	
		11	20457.0	65.4	19	1	1378.0	-	-	
		12	172285.0	92.3	19	3	1719.0	1896.0	1457.0	
		13	324865.0	93.7	19	3	1073.0	1141.0	1636.0	
		14	479256.0	64.1	19	1	1025.0	-	-	
		15	1631.0	66.0	19	1	1260.0	-	-	
		16	153780.0	83.9	19	3	1118.0	1789.0	1300.0	
		17	305818.0	97.2	19	3	1096.0	1728.0	1629.0	
		18	460387.0	58.2	19	1	1069.0	-	-	

Type 5 Radar Waveform_25

Download	25	Type 5	9	1.3333333	12.0000000	5.507000000				
		Burst ID	Burst Offset (us)	Pulse Width (us)	Chirp Width (MHz)	Number of Pulses per Burst	PRI-1 (us)	PRI-2 (us)	PRI-3 (us)	
		0	1294598.0	69.0	7	2	1122.0	1296.0	-	
		1	286364.0	79.3	7	2	1234.0	1684.0	-	
		2	608921.0	77.7	7	2	1920.0	1240.0	-	
		3	930649.0	83.5	7	3	1099.0	1992.0	1326.0	
		4	1255942.0	58.4	7	1	1247.0	-	-	
		5	246475.0	80.4	7	2	1694.0	1999.0	-	
		6	569767.0	55.4	7	1	1795.0	-	-	
		7	890292.0	84.4	7	3	1989.0	1428.0	1960.0	
		8	1212587.0	99.2	7	3	1952.0	1355.0	1839.0	

Type 5 Radar Waveform_26

Download	26	Type 5	11	1.0909091	12.0000000	5.506000000				
		Burst ID	Burst Offset (us)	Pulse Width (us)	Chirp Width (MHz)	Number of Pulses per Burst	PRI-1 (us)	PRI-2 (us)	PRI-3 (us)	
		0	168981.0	98.8	8	3	1699.0	1334.0	1150.0	
		1	432692.0	86.8	8	3	1625.0	1011.0	1181.0	
		2	895333.0	90.6	8	3	1951.0	1923.0	1524.0	
		3	960855.0	67.9	8	2	1462.0	1387.0	-	
		4	136836.0	54.6	8	1	1633.0	-	-	
		5	400226.0	94.9	8	3	1639.0	1077.0	1074.0	
		6	664308.0	74.9	8	2	1564.0	1536.0	-	
		7	929540.0	57.6	8	1	1454.0	-	-	
		8	103956.0	84.6	8	3	1919.0	1700.0	1545.0	
		9	367467.0	99.1	8	3	1718.0	1198.0	1708.0	
		10	631797.0	81.4	8	2	1359.0	1763.0	-	

Type 5 Radar Waveform_27

Download	27	Type 5	20	0.6000000	12.0000000	5.502000000				
		Burst ID	Burst Offset (us)	Pulse Width (us)	Chirp Width (MHz)	Number of Pulses per Burst	PRI-1 (us)	PRI-2 (us)	PRI-3 (us)	
		0	491171.0	96.3	20	3	1143.0	1256.0	1043.0	
		1	39204.0	83.7	20	3	1893.0	1828.0	1132.0	
		2	184003.0	82.4	20	2	1437.0	1933.0	--	
		3	328922.0	68.7	20	2	1281.0	1695.0	--	
		4	474765.0	57.6	20	1	1658.0	--	--	
		5	21435.0	88.5	20	3	1421.0	1278.0	1845.0	
		6	165755.0	89.8	20	3	1544.0	1932.0	1418.0	
		7	312097.0	58.5	20	1	1035.0	--	--	
		8	456967.0	58.2	20	1	1557.0	--	--	
		9	3649.0	94.9	20	3	1539.0	1455.0	1158.0	
		10	148040.0	91.2	20	3	1034.0	1637.0	1968.0	
		11	293875.0	63.2	20	1	1704.0	--	--	
		12	437295.0	84.7	20	3	1060.0	1521.0	1420.0	
		13	583061.0	67.0	20	2	1525.0	1229.0	--	
		14	131017.0	54.2	20	1	1149.0	--	--	
		15	276228.0	52.0	20	1	1213.0	--	--	
		16	420375.0	75.4	20	2	1592.0	1152.0	--	
		17	564887.0	78.3	20	2	1862.0	1243.0	--	
		18	113071.0	62.8	20	1	1445.0	--	--	
		19	256895.0	83.4	20	3	1476.0	1195.0	1891.0	

Type 5 Radar Waveform_28

Download	28	Type 5	13	0.9230769	12.0000000	5.505000000				
		Burst ID	Burst Offset (us)	Pulse Width (us)	Chirp Width (MHz)	Number of Pulses per Burst	PRI-1 (us)	PRI-2 (us)	PRI-3 (us)	
		0	620146.0	78.0	11	2	1657.0	1280.0	--	
		1	844638.0	53.8	11	1	1487.0	--	--	
		2	146299.0	73.4	11	2	1734.0	1409.0	--	
		3	368917.0	92.7	11	3	1100.0	1358.0	1917.0	
		4	592501.0	72.7	11	2	1610.0	1570.0	--	
		5	816046.0	68.0	11	2	1605.0	1078.0	--	
		6	118746.0	85.0	11	3	1014.0	1084.0	1591.0	
		7	342627.0	60.7	11	1	1267.0	--	--	
		8	564586.0	97.4	11	3	1367.0	1352.0	1167.0	
		9	788704.0	68.7	11	2	1125.0	1377.0	--	
		10	91451.0	56.5	11	1	1964.0	--	--	
		11	314335.0	81.4	11	2	1837.0	1635.0	--	
		12	537145.0	84.8	11	3	1259.0	1563.0	1031.0	

Type 5 Radar Waveform_29

Download	29	Type 5	12	1.0000000	12.0000000	5.505000000				
		Burst ID	Burst Offset (us)	Pulse Width (us)	Chirp Width (MHz)	Number of Pulses per Burst	PRI-1 (us)	PRI-2 (us)	PRI-3 (us)	
		0	825707.0	65.8	11	1	1416.0	--	--	
		1	69281.0	59.9	11	1	1852.0	--	--	
		2	310454.0	85.4	11	3	1274.0	1688.0	1804.0	
		3	551862.0	97.0	11	3	1803.0	1272.0	1632.0	
		4	795509.0	59.0	11	1	1875.0	--	--	
		5	39421.0	75.9	11	2	1822.0	1057.0	--	
		6	281380.0	69.9	11	2	1294.0	1137.0	--	
		7	522565.0	90.7	11	3	1411.0	1156.0	1308.0	
		8	763870.0	97.0	11	3	1052.0	1286.0	1911.0	
		9	9627.0	76.1	11	2	1985.0	1523.0	--	
		10	251937.0	54.3	11	1	1009.0	--	--	
		11	493823.0	57.5	11	1	1820.0	--	--	

Radar Type 6 - Radar Statistical Performance			
Trail #	1=Detection 0=No Detection	Trail #	1=Detection 0=No Detection
0	1	15	1
1	1	16	1
2	1	17	1
3	1	18	1
4	1	19	1
5	0	20	1
6	1	21	1
7	1	22	1
8	1	23	1
9	1	24	1
10	1	25	1
11	1	26	1
12	1	27	1
13	1	28	1
14	1	29	1
Detection Percentage (%)		96.7%	

Type 6 Radar Waveform_0

Download	0	Type 6	1.0	333.3	9	0.3333	300.0000000	3
		Frequency List (MHz)	0	1	2	3	4	
		0	5355	5329	5421	5339	5705	
		5	5517	5510	5554	5610	5674	
		10	5648	5427	5441	5508	5326	
		15	5687	5415	5668	5451	5669	
		20	5476	5484	5563	5591	5450	
		25	5607	5317	5330	5411	5268	
		30	5637	5513	5552	5622	5545	
		35	5582	5556	5496	5296	5619	
		40	5369	5657	5547	5393	5633	
		45	5540	5331	5631	5444	5379	
		50	5297	5608	5609	5693	5588	
		55	5652	5614	5348	5527	5353	
		60	5449	5278	5261	5711	5708	
		65	5506	5452	5584	5519	5405	
		70	5397	5357	5649	5266	5448	
		75	5542	5333	5424	5257	5696	
		80	5279	5629	5700	5654	5304	
		85	5655	5667	5398	5439	5458	
		90	5616	5382	5719	5651	5375	
		95	5520	5600	5550	5462	5567	

Type 6 Radar Waveform_1

Download	1	Type 6	1.0	333.3	9	0.3333	300.0000000	7
		Frequency List (MHz)	0	1	2	3	4	
		0	5610	5568	5357	5403	5450	
		5	5559	5435	5629	5676	5406	
		10	5579	5691	5703	5347	5300	
		15	5542	5296	5399	5483	5387	
		20	5553	5504	5583	5423	5495	
		25	5266	5436	5555	5445	5310	
		30	5526	5470	5292	5299	5365	
		35	5624	5647	5546	5533	5683	
		40	5265	5485	5633	5630	5469	
		45	5311	5714	5502	5335	5659	
		50	5484	5250	5307	5411	5499	
		55	5327	5302	5640	5724	5324	
		60	5578	5443	5303	5537	5654	
		65	5329	5401	5620	5254	5675	
		70	5635	5366	5297	5518	5276	
		75	5544	5400	5360	5473	5389	
		80	5507	5717	5301	5375	5570	
		85	5337	5631	5534	5706	5509	
		90	5677	5409	5657	5382	5257	
		95	5351	5655	5494	5295	5549	

Type 6 Radar Waveform_2

Download	2	Type 6	1.0	333.3	9	0.3333	300.0000000	3
		Frequency List (MHz)	0	1	2	3	4	
		0	5390	5332	5293	5564	5292	
		5	5601	5457	5704	5364	5613	
		10	5413	5480	5620	5423	5368	
		15	5388	5669	5399	5444	5675	
		20	5395	5719	5445	5672	5396	
		25	5383	5593	5639	5281	5479	
		30	5352	5512	5427	5507	5548	
		35	5563	5288	5263	5699	5447	
		40	5522	5348	5326	5398	5627	
		45	5322	5463	5449	5360	5486	
		50	5301	5612	5443	5515	5256	
		55	5355	5543	5295	5707	5608	
		60	5723	5400	5363	5697	5530	
		65	5350	5656	5561	5567	5478	
		70	5598	5621	5369	5524	5494	
		75	5710	5649	5341	5628	5499	
		80	5456	5402	5676	5667	5570	
		85	5654	5691	5251	5574	5540	
		90	5285	5319	5614	5460	5554	
		95	5518	5258	5428	5597	5590	

Type 6 Radar Waveform_3

Download	3	Type 6	1.0	333.3	9	0.3333	300.0000000	2
		Frequency List (MHz)	0	1	2	3	4	
		0	5645	5571	5704	5250	5512	
		5	5643	5382	5304	5527	5442	
		10	5344	5269	5661	5618	5389	
		15	5379	5699	5502	5489	5392	
		20	5403	5410	5483	5664	5369	
		25	5649	5445	5367	5385	5513	
		30	5394	5401	5384	5722	5700	
		35	5383	5427	5451	5456	5377	
		40	5458	5361	5528	5264	5541	
		45	5721	5705	5405	5521	5441	
		50	5336	5614	5662	5352	5582	
		55	5435	5290	5703	5685	5448	
		60	5362	5644	5298	5668	5707	
		65	5286	5353	5299	5595	5296	
		70	5281	5292	5607	5469	5373	
		75	5470	5669	5687	5589	5322	
		80	5544	5620	5465	5673	5387	
		85	5473	5496	5654	5346	5539	
		90	5514	5313	5695	5291	5399	
		95	5569	5599	5631	5407	5580	

Type 6 Radar Waveform_4

Download	4	Type 6	1. 0	333. 3	9	0. 3333	300. 0000000	2
		Frequency List (MHz)	0	1	2	3	4	
		0	5425	5335	5640	5411	5354	
		5	5307	5404	5379	5690	5649	
		10	5653	5533	5702	5338	5410	
		15	5467	5351	5508	5534	5584	
		20	5314	5479	5424	5278	5342	
		25	5537	5394	5570	5489	5547	
		30	5290	5341	5365	5474	5581	
		35	5566	5542	5252	5627	5372	
		40	5297	5611	5677	5306	5718	
		45	5634	5629	5488	5579	5494	
		50	5601	5490	5266	5403	5671	
		55	5258	5709	5416	5639	5636	
		60	5559	5615	5393	5463	5613	
		65	5539	5587	5589	5554	5723	
		70	5631	5603	5632	5364	5472	
		75	5697	5349	5628	5332	5257	
		80	5400	5657	5622	5325	5309	
		85	5528	5670	5582	5376	5435	
		90	5714	5538	5407	5468	5561	
		95	5418	5429	5281	5588	5345	

Type 6 Radar Waveform_5

Download	5	Type 6	1. 0	333. 3	9	0. 3333	300. 0000000	0
		Frequency List (MHz)	0	1	2	3	4	
		0	5583	5574	5576	5572	5349	
		5	5329	5454	5378	5381	5584	
		10	5419	5268	5436	5431	5555	
		15	5478	5611	5482	5301	5322	
		20	5645	5365	5270	5315	5328	
		25	5721	5298	5593	5581	5575	
		30	5276	5676	5580	5626	5401	
		35	5608	5633	5523	5305	5286	
		40	5694	5615	5546	5715	5466	
		45	5609	5571	5540	5547	5488	
		50	5366	5442	5285	5556	5653	
		55	5604	5353	5586	5522	5628	
		60	5655	5468	5510	5632	5377	
		65	5672	5667	5338	5524	5285	
		70	5325	5587	5459	5452	5303	
		75	5434	5257	5473	5688	5302	
		80	5376	5277	5677	5255	5372	
		85	5519	5334	5713	5594	5324	
		90	5541	5690	5702	5400	5567	
		95	5331	5357	5529	5256	5716	

Type 6 Radar Waveform_6

Download	6	Type 6	1.0	333.3	9	0.3333	300.0000000	3
		Frequency List (MHz)	0	1	2	3	4	
		0	5363	5338	5512	5258	5416	
		5	5391	5351	5529	5444	5685	
		10	5515	5683	5309	5631	5452	
		15	5643	5605	5714	5527	5493	
		20	5330	5403	5359	5288	5691	
		25	5670	5404	5697	5615	5617	
		30	5640	5633	5320	5400	5696	
		35	5272	5724	5458	5297	5450	
		40	5302	5553	5311	5712	5395	
		45	5589	5654	5598	5600	5278	
		50	5717	5618	5505	5374	5282	
		55	5500	5317	5547	5543	5672	
		60	5557	5651	5318	5300	5336	
		65	5578	5621	5606	5645	5319	
		70	5662	5575	5301	5546	5331	
		75	5475	5446	5362	5686	5270	
		80	5540	5276	5664	5594	5279	
		85	5262	5350	5715	5473	5582	
		90	5436	5284	5406	5261	5423	
		95	5324	5719	5455	5648	5422	

Type 6 Radar Waveform_7

Download	7	Type 6	1.0	333.3	9	0.3333	300.0000000	5
		Frequency List (MHz)	0	1	2	3	4	
		0	5618	5674	5448	5419	5636	
		5	5433	5276	5604	5607	5417	
		10	5349	5472	5350	5351	5473	
		15	5634	5257	5342	5572	5685	
		20	5716	5405	5344	5261	5482	
		25	5522	5423	5649	5281	5626	
		30	5590	5535	5552	5411	5340	
		35	5687	5708	5686	5289	5491	
		40	5454	5709	5324	5569	5262	
		45	5656	5556	5640	5496	5319	
		50	5560	5580	5444	5408	5501	
		55	5258	5431	5305	5483	5545	
		60	5637	5524	5304	5570	5642	
		65	5380	5346	5677	5270	5675	
		70	5622	5277	5505	5300	5595	
		75	5492	5343	5366	5704	5339	
		80	5564	5314	5657	5533	5700	
		85	5542	5583	5427	5355	5256	
		90	5449	5412	5295	5683	5336	
		95	5510	5632	5320	5252	5547	

Type 6 Radar Waveform_8

Download	8	Type 6	1. 0	333. 3	9	0. 3333	300. 0000000	5
		Frequency List (MHz)	0	1	2	3	4	
		0	5398	5438	5384	5483	5478	
		5	5572	5298	5679	5295	5624	
		10	5280	5261	5391	5546	5494	
		15	5722	5287	5445	5520	5499	
		20	5724	5474	5285	5440	5709	
		25	5370	5374	5335	5527	5683	
		30	5323	5515	5547	5653	5326	
		35	5714	5453	5528	5386	5600	
		40	5700	5565	5429	5694	5328	
		45	5631	5452	5345	5609	5430	
		50	5372	5495	5607	5649	5403	
		55	5291	5596	5358	5448	5688	
		60	5402	5434	5648	5587	5439	
		65	5560	5470	5602	5519	5581	
		70	5687	5481	5371	5256	5678	
		75	5471	5253	5464	5289	5715	
		80	5635	5324	5618	5393	5399	
		85	5561	5509	5657	5375	5637	
		90	5548	5506	5454	5614	5418	
		95	5707	5278	5616	5693	5583	

Type 6 Radar Waveform_9

Download	9	Type 6	1. 0	333. 3	9	0. 3333	300. 0000000	3
		Frequency List (MHz)	0	1	2	3	4	
		0	5556	5677	5320	5644	5698	
		5	5614	5279	5458	5453	5686	
		10	5525	5529	5266	5515	5335	
		15	5414	5451	5565	5691	5257	
		20	5640	5701	5432	5682	5636	
		25	5323	5538	5631	5717	5365	
		30	5404	5504	5393	5478	5437	
		35	5592	5619	5539	5611	5648	
		40	5367	5459	5325	5560	5428	
		45	5675	5662	5317	5723	5671	
		50	5658	5263	5710	5309	5312	
		55	5638	5507	5373	5466	5338	
		60	5532	5368	5386	5513	5328	
		65	5468	5617	5519	5276	5427	
		70	5443	5681	5704	5423	5616	
		75	5360	5303	5305	5395	5503	
		80	5655	5557	5562	5558	5314	
		85	5354	5416	5652	5304	5424	
		90	5447	5457	5392	5620	5697	
		95	5591	5465	5271	5270	5711	

Type 6 Radar Waveform_10

Download	10	Type 6	1.0	333.3	9	0.3333	300.0000000	4
		Frequency List (MHz)	0	1	2	3	4	
		0	5336	5441	5256	5330	5540	
		5	5656	5720	5354	5524	5660	
		10	5520	5411	5570	5364	5536	
		15	5423	5541	5554	5610	5408	
		20	5643	5709	5264	5521	5655	
		25	5650	5266	5260	5276	5504	
		30	5390	5461	5608	5252	5257	
		35	5710	5647	5314	5525	5378	
		40	5353	5683	5699	5322	5392	
		45	5412	5258	5715	5582	5502	
		50	5372	5352	5427	5557	5497	
		55	5326	5344	5595	5503	5477	
		60	5675	5687	5459	5626	5417	
		65	5653	5254	5612	5703	5306	
		70	5644	5583	5382	5585	5480	
		75	5349	5286	5613	5436	5624	
		80	5625	5555	5424	5560	5631	
		85	5308	5546	5381	5483	5527	
		90	5472	5469	5430	5300	5707	
		95	5566	5409	5681	5489	5444	

Type 6 Radar Waveform_11

Download	11	Type 6	1.0	333.3	9	0.3333	300.0000000	5
		Frequency List (MHz)	0	1	2	3	4	
		0	5591	5680	5667	5491	5285	
		5	5698	5645	5429	5687	5392	
		10	5451	5675	5611	5559	5557	
		15	5414	5668	5657	5655	5600	
		20	5651	5400	5513	5628	5412	
		25	5599	5372	5461	5310	5546	
		30	5279	5418	5348	5404	5455	
		35	5395	5326	5443	5467	5439	
		40	5692	5436	5621	5367	5319	
		45	5321	5691	5316	5293	5469	
		50	5378	5548	5538	5250	5501	
		55	5685	5695	5446	5523	5693	
		60	5724	5422	5507	5610	5405	
		65	5352	5366	5592	5561	5438	
		70	5411	5684	5311	5309	5396	
		75	5341	5457	5503	5492	5267	
		80	5424	5626	5313	5688	5552	
		85	5716	5463	5473	5271	5641	
		90	5437	5300	5670	5634	5533	
		95	5712	5589	5426	5255	5665	

Type 6 Radar Waveform_12

Download	12	Type 6	1.0	333.3	9	0.3333	300.0000000	2
		Frequency List (MHz)	0	1	2	3	4	
		0	5371	5444	5603	5652	5602	
		5	5362	5667	5504	5375	5599	
		10	5285	5464	5279	5578	5502	
		15	5320	5317	5659	5566	5621	
		20	5601	5678	5451	5575	5565	
		25	5722	5588	5643	5466	5653	
		30	5275	5437	5417	5714	5620	
		35	5353	5531	5519	5559	5607	
		40	5316	5250	5372	5299	5277	
		45	5346	5259	5254	5724	5336	
		50	5627	5548	5348	5398	5649	
		55	5636	5342	5664	5378	5358	
		60	5339	5436	5448	5650	5315	
		65	5628	5296	5330	5689	5297	
		70	5409	5720	5535	5300	5426	
		75	5623	5538	5723	5579	5261	
		80	5473	5477	5373	5549	5366	
		85	5412	5331	5488	5490	5324	
		90	5539	5271	5374	5687	5443	
		95	5310	5382	5305	5580	5486	

Type 6 Radar Waveform_13

Download	13	Type 6	1.0	333.3	9	0.3333	300.0000000	5
		Frequency List (MHz)	0	1	2	3	4	
		0	5626	5683	5539	5336	5347	
		5	5404	5592	5579	5538	5428	
		10	5691	5253	5693	5474	5599	
		15	5590	5350	5388	5648	5509	
		20	5570	5635	5659	5594	5574	
		25	5566	5303	5669	5281	5252	
		30	5629	5332	5681	5330	5576	
		35	5508	5607	5298	5364	5467	
		40	5602	5497	5372	5410	5557	
		45	5352	5382	5335	5302	5621	
		50	5605	5425	5387	5716	5371	
		55	5292	5489	5603	5351	5636	
		60	5507	5523	5409	5646	5359	
		65	5394	5376	5264	5567	5600	
		70	5492	5450	5283	5412	5569	
		75	5511	5259	5268	5326	5356	
		80	5254	5641	5436	5449	5631	
		85	5366	5294	5453	5442	5321	
		90	5688	5545	5256	5460	5365	
		95	5255	5280	5662	5684	5446	

Type 6 Radar Waveform_14

Download	14	Type 6	1.0	333.3	9	0.3333	300.0000000	5
		Frequency List (MHz)	0	1	2	3	4	
		0	5309	5447	5475	5499	5664	
		5	5446	5614	5654	5604	5635	
		10	5622	5517	5259	5669	5620	
		15	5678	5477	5394	5693	5701	
		20	5578	5326	5600	5683	5547	
		25	5357	5252	5506	5298	5315	
		30	5294	5518	5289	5421	5579	
		35	5293	5715	5696	5403	5548	
		40	5278	5306	5307	5435	5515	
		45	5407	5486	5710	5465	5393	
		50	5355	5411	5384	5601	5438	
		55	5330	5572	5677	5557	5541	
		60	5455	5606	5636	5688	5354	
		65	5575	5660	5340	5577	5603	
		70	5338	5492	5295	5522	5269	
		75	5512	5418	5487	5267	5388	
		80	5608	5510	5708	5351	5571	
		85	5257	5645	5493	5569	5508	
		90	5551	5717	5613	5430	5574	
		95	5420	5714	5653	5641	5311	

Type 6 Radar Waveform_15

Download	15	Type 6	1.0	333.3	9	0.3333	300.0000000	3
		Frequency List (MHz)	0	1	2	3	4	
		0	5564	5686	5411	5660	5409	
		5	5488	5539	5632	5292	5367	
		10	5456	5403	5300	5641	5669	
		15	5604	5497	5263	5418	5586	
		20	5395	5541	5675	5520	5720	
		25	5579	5709	5499	5349	5336	
		30	5407	5721	5636	5256	5588	
		35	5282	5312	5674	5701	5667	
		40	5620	5390	5373	5280	5404	
		45	5318	5690	5548	5354	5408	
		50	5298	5260	5302	5489	5419	
		55	5558	5511	5652	5480	5668	
		60	5378	5299	5486	5286	5400	
		65	5637	5639	5645	5287	5476	
		70	5691	5352	5515	5267	5366	
		75	5614	5288	5385	5494	5291	
		80	5397	5562	5443	5546	5647	
		85	5510	5317	5362	5447	5342	
		90	5706	5344	5654	5398	5442	
		95	5591	5475	5320	5551	5523	

Type 6 Radar Waveform_16

Download	16	Type 6	1. 0	333. 3	9	0. 3333	300. 0000000	7
		Frequency List (MHz)	0	1	2	3	4	
		0	5344	5450	5347	5724	5251	
		5	5627	5561	5707	5455	5671	
		10	5387	5667	5341	5487	5662	
		15	5282	5256	5600	5686	5497	
		20	5579	5289	5493	5511	5528	
		25	5340	5603	5383	5378	5393	
		30	5678	5279	5505	5311	5421	
		35	5403	5470	5379	5459	5473	
		40	5520	5401	5722	5670	5631	
		45	5412	5461	5563	5611	5478	
		50	5540	5605	5693	5405	5578	
		55	5465	5446	5471	5451	5322	
		60	5543	5714	5409	5329	5601	
		65	5683	5380	5557	5288	5338	
		70	5518	5494	5342	5583	5531	
		75	5441	5269	5637	5604	5547	
		80	5440	5363	5647	5352	5280	
		85	5457	5355	5498	5526	5509	
		90	5660	5688	5551	5608	5530	
		95	5304	5449	5502	5517	5425	

Type 6 Radar Waveform_17

Download	17	Type 6	1. 0	333. 3	9	0. 3333	300. 0000000	2
		Frequency List (MHz)	0	1	2	3	4	
		0	5599	5689	5283	5410	5471	
		5	5669	5486	5307	5618	5403	
		10	5318	5456	5479	5682	5683	
		15	5370	5383	5703	5256	5424	
		20	5505	5630	5520	5281	5466	
		25	5399	5380	5543	5707	5417	
		30	5517	5282	5635	5494	5657	
		35	5606	5560	5363	5629	5592	
		40	5395	5653	5627	5285	5398	
		45	5651	5650	5714	5470	5514	
		50	5450	5487	5654	5591	5694	
		55	5516	5349	5291	5419	5539	
		60	5290	5422	5451	5708	5286	
		65	5546	5710	5275	5632	5614	
		70	5687	5449	5557	5457	5324	
		75	5343	5570	5552	5584	5250	
		80	5414	5617	5328	5310	5437	
		85	5558	5550	5340	5649	5698	
		90	5452	5266	5724	5674	5666	
		95	5625	5540	5660	5585	5288	

Type 6 Radar Waveform_18

Download	18	Type 6	1.0	333.3	9	0.3333	300.0000000	4
		Frequency List (MHz)	0	1	2	3	4	
		0	5282	5453	5694	5571	5313	
		5	5711	5508	5382	5684	5610	
		10	5627	5720	5520	5402	5704	
		15	5458	5413	5331	5301	5616	
		20	5513	5321	5461	5370	5439	
		25	5287	5707	5271	5336	5451	
		30	5559	5268	5592	5709	5431	
		35	5329	5699	5585	5634	5307	
		40	5506	5261	5565	5428	5492	
		45	5483	5630	5322	5567	5715	
		50	5266	5355	5642	5308	5339	
		55	5671	5479	5373	5254	5487	
		60	5393	5580	5398	5706	5378	
		65	5536	5696	5625	5581	5553	
		70	5422	5719	5360	5529	5310	
		75	5621	5667	5294	5424	5296	
		80	5252	5569	5584	5317	5337	
		85	5278	5608	5303	5366	5663	
		90	5503	5514	5544	5364	5672	
		95	5659	5264	5640	5369	5342	

Type 6 Radar Waveform_19

Download	19	Type 6	1.0	333.3	9	0.3333	300.0000000	3
		Frequency List (MHz)	0	1	2	3	4	
		0	5537	5692	5630	5257	5533	
		5	5375	5433	5457	5372	5439	
		10	5558	5509	5561	5597	5250	
		15	5449	5540	5337	5724	5333	
		20	5424	5390	5499	5362	5412	
		25	5553	5656	5474	5485	5601	
		30	5632	5549	5583	5624	5266	
		35	5298	5430	5460	5517	5548	
		40	5344	5503	5668	5489	5610	
		45	5405	5523	5602	5617	5531	
		50	5693	5397	5615	5667	5327	
		55	5444	5306	5267	5709	5563	
		60	5651	5307	5459	5264	5448	
		65	5530	5589	5254	5611	5638	
		70	5698	5393	5721	5516	5270	
		75	5488	5416	5687	5346	5265	
		80	5365	5481	5334	5473	5453	
		85	5450	5363	5461	5287	5529	
		90	5678	5304	5281	5695	5353	
		95	5715	5342	5351	5641	5349	

Type 6 Radar Waveform_20

Download	20	Type 6	1.0	333.3	9	0.3333	300.0000000	4
		Frequency List (MHz)	0	1	2	3	4	
		0	5317	5456	5566	5418	5375	
		5	5417	5455	5532	5535	5646	
		10	5489	5395	5602	5695	5271	
		15	5537	5667	5440	5294	5625	
		20	5432	5556	5451	5385	5441	
		25	5508	5677	5641	5519	5265	
		30	5521	5506	5567	5357	5444	
		35	5405	5389	5323	5710	5431	
		40	5387	5427	5433	5486	5719	
		45	5590	5488	5547	5576	5392	
		50	5493	5707	5269	5583	5363	
		55	5462	5283	5659	5634	5600	
		60	5713	5266	5253	5693	5614	
		65	5285	5685	5649	5479	5625	
		70	5464	5406	5344	5295	5379	
		75	5724	5268	5721	5447	5439	
		80	5668	5598	5621	5645	5596	
		85	5331	5356	5326	5653	5496	
		90	5411	5562	5694	5306	5630	
		95	5564	5318	5298	5275	5337	

Type 6 Radar Waveform_21

Download	21	Type 6	1.0	333.3	9	0.3333	300.0000000	4
		Frequency List (MHz)	0	1	2	3	4	
		0	5572	5695	5502	5579	5595	
		5	5459	5380	5607	5698	5378	
		10	5323	5659	5643	5415	5292	
		15	5625	5319	5543	5339	5717	
		20	5440	5381	5443	5358	5707	
		25	5457	5308	5270	5553	5307	
		30	5507	5463	5509	5642	5544	
		35	5480	5594	5388	5345	5701	
		40	5379	5673	5483	5648	5473	
		45	5571	5508	5629	5279	5272	
		50	5408	5320	5672	5661	5406	
		55	5471	5613	5349	5419	5684	
		60	5395	5418	5638	5446	5683	
		65	5631	5472	5428	5564	5296	
		70	5676	5622	5464	5365	5592	
		75	5600	5709	5559	5487	5649	
		80	5375	5485	5402	5334	5328	
		85	5259	5706	5386	5273	5364	
		90	5462	5285	5287	5312	5664	
		95	5427	5315	5330	5511	5678	

Type 6 Radar Waveform_22

Download	22	Type 6	1. 0	333. 3	9	0. 3333	300. 0000000	4
		Frequency List (MHz)	0	1	2	3	4	
		0	5352	5556	5438	5265	5437	
		5	5501	5402	5682	5289	5254	
		10	5448	5684	5610	5313	5713	
		15	5446	5646	5384	5434	5351	
		20	5316	5322	5532	5331	5595	
		25	5309	5511	5374	5587	5349	
		30	5396	5420	5522	5283	5462	
		35	5586	5571	5390	5541	5356	
		40	5637	5690	5317	5341	5480	
		45	5577	5453	5654	5566	5544	
		50	5623	5584	5371	5286	5484	
		55	5253	5659	5567	5539	5616	
		60	5655	5524	5583	5278	5509	
		65	5674	5673	5377	5600	5506	
		70	5568	5425	5536	5441	5576	
		75	5365	5581	5679	5630	5252	
		80	5627	5498	5658	5722	5325	
		85	5680	5259	5548	5465	5329	
		90	5416	5483	5452	5318	5601	
		95	5706	5429	5385	5409	5560	

Type 6 Radar Waveform_23

Download	23	Type 6	1. 0	333. 3	9	0. 3333	300. 0000000	1
		Frequency List (MHz)	0	1	2	3	4	
		0	5510	5320	5374	5329	5657	
		5	5640	5327	5282	5452	5414	
		10	5563	5712	5250	5330	5334	
		15	5704	5476	5274	5332	5626	
		20	5359	5482	5360	5524	5304	
		25	5386	5258	5714	5575	5621	
		30	5488	5285	5377	5262	5435	
		35	5660	5662	5283	5316	5270	
		40	5298	5255	5581	5477	5409	
		45	5433	5624	5260	5431	5499	
		50	5422	5375	5685	5672	5372	
		55	5521	5254	5529	5653	5273	
		60	5625	5682	5335	5620	5399	
		65	5326	5636	5338	5363	5703	
		70	5705	5434	5290	5552	5324	
		75	5550	5676	5708	5307	5608	
		80	5439	5565	5407	5700	5400	
		85	5637	5487	5467	5707	5303	
		90	5617	5635	5588	5548	5446	
		95	5343	5539	5288	5580	5632	

Type 6 Radar Waveform_24

Download	24	Type 6	1.0	333.3	9	0.3333	300.0000000	6
		Frequency List (MHz)	0	1	2	3	4	
		0	5290	5559	5310	5490	5499	
		5	5682	5349	5357	5615	5621	
		10	5494	5501	5291	5525	5355	
		15	5317	5603	5280	5377	5440	
		20	5367	5551	5301	5613	5277	
		25	5274	5585	5442	5679	5655	
		30	5530	5271	5334	5380	5684	
		35	5480	5389	5375	5554	5469	
		40	5659	5315	5381	5668	5346	
		45	5571	5338	5413	5345	5313	
		50	5696	5461	5473	5464	5508	
		55	5519	5560	5475	5347	5254	
		60	5500	5307	5438	5570	5514	
		65	5258	5566	5697	5275	5575	
		70	5548	5255	5506	5302	5420	
		75	5455	5614	5528	5283	5422	
		80	5344	5689	5718	5695	5470	
		85	5595	5540	5329	5372	5637	
		90	5421	5427	5572	5373	5657	
		95	5463	5398	5467	5391	5400	

Type 6 Radar Waveform_25

Download	25	Type 6	1.0	333.3	9	0.3333	300.0000000	4
		Frequency List (MHz)	0	1	2	3	4	
		0	5545	5323	5721	5651	5719	
		5	5724	5371	5432	5303	5450	
		10	5425	5387	5429	5623	5376	
		15	5405	5255	5383	5422	5632	
		20	5278	5717	5605	5250	5637	
		25	5437	5645	5308	5689	5572	
		30	5635	5291	5595	5361	5678	
		35	5528	5466	5350	5622	5670	
		40	5629	5561	5509	5489	5568	
		45	5393	5428	5643	5269	5583	
		50	5524	5650	5331	5463	5273	
		55	5537	5451	5471	5339	5603	
		60	5515	5346	5559	5512	5423	
		65	5699	5611	5380	5525	5687	
		70	5374	5406	5458	5366	5504	
		75	5391	5467	5390	5336	5256	
		80	5476	5418	5533	5694	5412	
		85	5540	5268	5469	5505	5472	
		90	5253	5321	5433	5606	5480	
		95	5453	5675	5400	5494	5598	

Type 6 Radar Waveform_26

Download	26	Type 6	1.0	333.3	9	0.3333	300.0000000	7
		Frequency List (MHz)	0	1	2	3	4	
		0	5325	5562	5657	5337	5561	
		5	5291	5296	5507	5466	5259	
		10	5651	5470	5343	5397	5493	
		15	5382	5486	5467	5349	5286	
		20	5311	5280	5694	5698	5428	
		25	5386	5276	5412	5723	5711	
		30	5524	5335	5610	5498	5570	
		35	5557	5621	5584	5565	5644	
		40	5447	5254	5574	5373	5511	
		45	5701	5322	5505	5338	5575	
		50	5264	5629	5310	5364	5383	
		55	5252	5270	5442	5468	5293	
		60	5460	5653	5385	5555	5721	
		65	5648	5550	5590	5320	5490	
		70	5543	5489	5558	5690	5480	
		75	5676	5360	5587	5533	5588	
		80	5366	5257	5582	5596	5691	
		85	5607	5443	5585	5395	5564	
		90	5426	5501	5519	5637	5439	
		95	5612	5303	5497	5508	5435	

Type 6 Radar Waveform_27

Download	27	Type 6	1.0	333.3	9	0.3333	300.0000000	6
		Frequency List (MHz)	0	1	2	3	4	
		0	5483	5326	5593	5498	5306	
		5	5430	5318	5582	5532	5389	
		10	5665	5440	5511	5538	5418	
		15	5581	5509	5589	5415	5541	
		20	5294	5477	5696	5686	5671	
		25	5316	5713	5479	5516	5282	
		30	5278	5510	5680	5550	5287	
		35	5709	5648	5514	5404	5252	
		40	5385	5494	5562	5503	5256	
		45	5594	5662	5375	5260	5381	
		50	5626	5353	5355	5254	5552	
		55	5337	5442	5564	5597	5458	
		60	5502	5485	5308	5501	5447	
		65	5586	5422	5687	5293	5615	
		70	5475	5561	5539	5359	5635	
		75	5707	5676	5632	5365	5379	
		80	5513	5649	5281	5688	5327	
		85	5346	5427	5358	5338	5274	
		90	5339	5445	5577	5397	5412	
		95	5611	5563	5471	5261	5700	

Type 6 Radar Waveform_28

Download	28	Type 6	1.0	333.3	9	0.3333	300.0000000	3
		Frequency List (MHz)	0	1	2	3	4	
		0	5263	5565	5529	5659	5623	
		5	5472	5718	5657	5695	5596	
		10	5704	5552	5258	5439	5572	
		15	5539	5692	5460	5680	5546	
		20	5637	5300	5644	5582	5662	
		25	5682	5717	5316	5320	5399	
		30	5668	5536	5516	5373	5264	
		35	5310	5703	5509	5432	5323	
		40	5259	5559	5335	5711	5677	
		45	5720	5428	5525	5257	5690	
		50	5442	5653	5576	5265	5291	
		55	5632	5363	5287	5251	5447	
		60	5414	5609	5270	5622	5482	
		65	5571	5309	5461	5661	5388	
		70	5594	5676	5352	5722	5613	
		75	5617	5489	5294	5338	5344	
		80	5588	5522	5346	5366	5418	
		85	5473	5681	5431	5537	5492	
		90	5451	5611	5279	5521	5628	
		95	5618	5500	5369	5328	5339	

Type 6 Radar Waveform_29

Download	29	Type 6	1.0	333.3	9	0.3333	300.0000000	4
		Frequency List (MHz)	0	1	2	3	4	
		0	5518	5329	5465	5345	5368	
		5	5514	5265	5257	5383	5425	
		10	5430	5493	5593	5356	5460	
		15	5660	5666	5698	5505	5450	
		20	5688	5712	5675	5292	5617	
		25	5470	5410	5346	5350	5362	
		30	5385	5594	5408	5336	5415	
		35	5355	5581	5478	5423	5557	
		40	5515	5261	5402	5653	5264	
		45	5691	5285	5303	5481	5412	
		50	5511	5391	5253	5628	5476	
		55	5520	5453	5720	5347	5580	
		60	5258	5380	5313	5392	5721	
		65	5532	5490	5471	5495	5561	
		70	5464	5374	5381	5447	5664	
		75	5615	5311	5553	5548	5375	
		80	5390	5297	5599	5550	5502	
		85	5407	5585	5717	5724	5683	
		90	5568	5646	5482	5295	5357	
		95	5657	5554	5539	5533	5645	

Test Site	SIP-TR2	Test Engineer	Alisa Deng
Test Date	2023-03-26		
Test Item	Radar Statistical Performance Check (802.11ax-HE40 – 5510MHz)		

Radar Type 1-4 - Radar Statistical Performance								
Trial	Radar Type 1		Radar Type 2		Radar Type 3		Radar Type 4	
	Frequency (MHz)	1=detect 0=no detect	Frequency (MHz)	1=detect 0=no detect	Frequency (MHz)	1=detect 0=no detect	Frequency (MHz)	1=detect 0=no detect
0	5491	0	5500	1	5519	1	5516	0
1	5527	1	5528	1	5525	1	5494	1
2	5515	1	5529	1	5508	1	5497	1
3	5499	1	5512	1	5516	1	5505	1
4	5493	1	5492	1	5527	1	5515	1
5	5530	1	5523	1	5524	1	5502	1
6	5505	1	5499	1	5491	0	5526	1
7	5508	1	5519	1	5515	1	5507	1
8	5505	1	5491	0	5514	1	5491	0
9	5492	1	5510	0	5503	0	5503	1
10	5491	0	5498	1	5514	1	5499	1
11	5498	1	5499	1	5491	1	5519	1
12	5529	1	5496	1	5518	1	5529	0
13	5523	1	5491	1	5503	1	5510	1
14	5502	1	5526	1	5499	1	5503	1
15	5495	1	5522	1	5495	1	5519	1
16	5493	1	5491	0	5502	1	5522	0
17	5504	1	5520	1	5510	1	5510	1
18	5493	1	5499	1	5497	1	5524	1
19	5498	1	5519	1	5491	0	5493	1
20	5523	1	5514	1	5512	1	5508	1
21	5510	0	5492	1	5528	1	5491	1
22	5508	1	5496	1	5506	1	5500	1
23	5525	1	5506	1	5512	1	5492	1
24	5496	1	5506	1	5505	1	5494	0
25	5492	1	5526	1	5508	1	5502	1
26	5501	1	5495	1	5523	1	5512	0



Radar Type 1-4 - Radar Statistical Performance								
Trial	Radar Type 1		Radar Type 2		Radar Type 3		Radar Type 4	
	Frequency (MHz)	1=detect 0=no detect	Frequency (MHz)	1=detect 0=no detect	Frequency (MHz)	1=detect 0=no detect	Frequency (MHz)	1=detect 0=no detect
27	5505	1	5503	1	5529	0	5529	0
28	5520	1	5504	1	5516	1	5527	1
29	5509	1	5502	1	5506	1	5515	1
Probability:	90.0%		90.0%		86.7%		76.7%	
Aggregate:	85.85% (>80%)							

Radar Type 1 - Radar Waveform							Radar Type 2 - Radar Waveform						
Trial List							Trial List						
	Trial Id	Radar Type	Pulse Width (us)	PRI (us)	Number of Pulses	Waveform Length (us)		Trial Id	Radar Type	Pulse Width (us)	PRI (us)	Number of Pulses	Waveform Length (us)
Download	0	Type 1	1.0	658.0	81	53298.0	Download	0	Type 2	3.3	186.0	27	5022.0
Download	1	Type 1	1.0	798.0	67	53466.0	Download	1	Type 2	3.9	167.0	28	4676.0
Download	2	Type 1	1.0	778.0	68	52904.0	Download	2	Type 2	1.2	199.0	23	4577.0
Download	3	Type 1	1.0	818.0	65	53170.0	Download	3	Type 2	1.5	205.0	24	4920.0
Download	4	Type 1	1.0	3066.0	18	55188.0	Download	4	Type 2	4.8	190.0	29	5510.0
Download	5	Type 1	1.0	838.0	63	52794.0	Download	5	Type 2	4.3	203.0	28	5684.0
Download	6	Type 1	1.0	938.0	57	53466.0	Download	6	Type 2	2.6	222.0	25	5550.0
Download	7	Type 1	1.0	698.0	76	53048.0	Download	7	Type 2	2.0	221.0	24	5304.0
Download	8	Type 1	1.0	518.0	102	52836.0	Download	8	Type 2	4.7	218.0	29	6322.0
Download	9	Type 1	1.0	618.0	86	53148.0	Download	9	Type 2	1.6	228.0	24	5472.0
Download	10	Type 1	1.0	538.0	99	53262.0	Download	10	Type 2	2.3	155.0	25	3675.0
Download	11	Type 1	1.0	578.0	92	53176.0	Download	11	Type 2	3.2	197.0	26	5122.0
Download	12	Type 1	1.0	558.0	95	53010.0	Download	12	Type 2	4.1	226.0	28	6328.0
Download	13	Type 1	1.0	918.0	58	53244.0	Download	13	Type 2	3.6	164.0	27	4428.0
Download	14	Type 1	1.0	678.0	78	52884.0	Download	14	Type 2	1.4	185.0	23	4255.0
Download	15	Type 1	1.0	708.0	75	53100.0	Download	15	Type 2	5.0	172.0	29	4988.0
Download	16	Type 1	1.0	2147.0	25	53675.0	Download	16	Type 2	4.6	209.0	29	6061.0
Download	17	Type 1	1.0	2420.0	22	53240.0	Download	17	Type 2	4.3	166.0	28	4648.0
Download	18	Type 1	1.0	914.0	58	53012.0	Download	18	Type 2	4.6	225.0	29	6525.0
Download	19	Type 1	1.0	1182.0	45	53190.0	Download	19	Type 2	2.6	154.0	25	3850.0
Download	20	Type 1	1.0	618.0	86	53148.0	Download	20	Type 2	1.5	210.0	23	4830.0
Download	21	Type 1	1.0	1404.0	38	53352.0	Download	21	Type 2	4.2	175.0	28	4900.0
Download	22	Type 1	1.0	2305.0	23	53015.0	Download	22	Type 2	5.0	196.0	29	5684.0
Download	23	Type 1	1.0	1299.0	41	53259.0	Download	23	Type 2	1.8	227.0	24	5448.0
Download	24	Type 1	1.0	1602.0	33	52866.0	Download	24	Type 2	5.0	230.0	29	6670.0
Download	25	Type 1	1.0	659.0	81	53379.0	Download	25	Type 2	4.1	208.0	28	5624.0
Download	26	Type 1	1.0	520.0	102	53040.0	Download	26	Type 2	1.4	151.0	23	3473.0
Download	27	Type 1	1.0	667.0	80	53360.0	Download	27	Type 2	3.5	152.0	27	4104.0
Download	28	Type 1	1.0	1807.0	30	54210.0	Download	28	Type 2	3.8	158.0	27	4266.0
Download	29	Type 1	1.0	2712.0	20	54240.0	Download	29	Type 2	1.7	156.0	24	3744.0



Radar Type 3 - Radar Waveform							Radar Type 4 - Radar Waveform						
Trial List							Trial List						
	Trial Id	Radar Type	Pulse Width (us)	PRI (us)	Number of Pulses	Waveform Length (us)		Trial Id	Radar Type	Pulse Width (us)	PRI (us)	Number of Pulses	Waveform Length (us)
Download	0	Type 3	8.3	321.0	17	5457.0	Download	0	Type 4	16.2	321.0	14	4494.0
Download	1	Type 3	8.9	369.0	18	6642.0	Download	1	Type 4	17.5	369.0	15	5535.0
Download	2	Type 3	6.2	200.0	16	3200.0	Download	2	Type 4	11.6	200.0	12	2400.0
Download	3	Type 3	6.5	338.0	16	5408.0	Download	3	Type 4	12.3	338.0	12	4056.0
Download	4	Type 3	9.8	443.0	18	7974.0	Download	4	Type 4	19.5	443.0	16	7088.0
Download	5	Type 3	9.3	216.0	18	3888.0	Download	5	Type 4	18.3	216.0	16	3456.0
Download	6	Type 3	7.6	499.0	17	8483.0	Download	6	Type 4	14.7	499.0	14	6986.0
Download	7	Type 3	7.0	302.0	16	4832.0	Download	7	Type 4	13.3	302.0	13	3926.0
Download	8	Type 3	9.7	496.0	18	8928.0	Download	8	Type 4	19.3	496.0	16	7936.0
Download	9	Type 3	6.6	417.0	16	6672.0	Download	9	Type 4	12.3	417.0	12	5004.0
Download	10	Type 3	7.3	208.0	17	3536.0	Download	10	Type 4	14.0	208.0	13	2704.0
Download	11	Type 3	8.2	323.0	17	5491.0	Download	11	Type 4	16.0	323.0	14	4522.0
Download	12	Type 3	9.1	360.0	18	6480.0	Download	12	Type 4	17.9	360.0	15	5400.0
Download	13	Type 3	8.6	315.0	17	5355.0	Download	13	Type 4	16.9	315.0	15	4725.0
Download	14	Type 3	6.4	405.0	16	6480.0	Download	14	Type 4	11.9	405.0	12	4860.0
Download	15	Type 3	10.0	251.0	18	4518.0	Download	15	Type 4	20.0	251.0	16	4016.0
Download	16	Type 3	9.6	449.0	18	8082.0	Download	16	Type 4	19.0	449.0	16	7184.0
Download	17	Type 3	9.3	324.0	18	5832.0	Download	17	Type 4	18.5	324.0	16	5184.0
Download	18	Type 3	9.6	312.0	18	5616.0	Download	18	Type 4	19.1	312.0	16	4992.0
Download	19	Type 3	7.6	203.0	17	3451.0	Download	19	Type 4	14.5	203.0	13	2639.0
Download	20	Type 3	6.5	340.0	16	5440.0	Download	20	Type 4	12.1	340.0	12	4080.0
Download	21	Type 3	9.2	270.0	18	4860.0	Download	21	Type 4	18.2	270.0	15	4050.0
Download	22	Type 3	10.0	420.0	18	7560.0	Download	22	Type 4	20.0	420.0	16	6720.0
Download	23	Type 3	6.8	271.0	16	4336.0	Download	23	Type 4	12.8	271.0	13	3523.0
Download	24	Type 3	10.0	370.0	18	6660.0	Download	24	Type 4	20.0	370.0	16	5920.0
Download	25	Type 3	9.1	284.0	18	5112.0	Download	25	Type 4	18.0	284.0	15	4260.0
Download	26	Type 3	6.4	412.0	16	6592.0	Download	26	Type 4	11.9	412.0	12	4944.0
Download	27	Type 3	8.5	326.0	17	5542.0	Download	27	Type 4	16.5	326.0	15	4890.0
Download	28	Type 3	8.8	429.0	18	7722.0	Download	28	Type 4	17.4	429.0	15	6435.0
Download	29	Type 3	6.7	239.0	16	3824.0	Download	29	Type 4	12.6	239.0	12	2868.0

Radar Type 5 - Radar Statistical Performance					
Trail #	Test Freq. (MHz)	1=Detection 0=No Detection	Trail #	Test Freq. (MHz)	1=Detection 0=No Detection
0	5510	0	15	5499	1
1	5510	1	16	5499	1
2	5510	0	17	5498	1
3	5510	1	18	5499	1
4	5510	1	19	5496	1
5	5510	1	20	5526	1
6	5510	0	21	5522	1
7	5510	1	22	5521	1
8	5510	1	23	5526	1
9	5510	1	24	5521	1
10	5495	0	25	5522	1
11	5496	1	26	5526	1
12	5498	1	27	5523	1
13	5497	1	28	5522	1
14	5494	1	29	5526	1
Detection Percentage (%)			86.7%		

Type 5 Radar Waveform_0

Download	0	Type 5	15	0.8000000	12.0000000	5.510000000				
		Burst ID	Burst Offset (us)	Pulse Width (us)	Chirp Width (MHz)	Number of Pulses per Burst	PRI-1 (us)	PRI-2 (us)	PRI-3 (us)	
		0	651537.0	78.8	14	2	1897.0	1857.0	--	
		1	48337.0	86.1	14	3	1862.0	1976.0	1061.0	
		2	242214.0	53.3	14	1	1470.0	--	--	
		3	435731.0	57.2	14	1	1747.0	--	--	
		4	627443.0	96.9	14	3	1828.0	1002.0	1314.0	
		5	24584.0	90.4	14	3	1855.0	1842.0	1185.0	
		6	217952.0	70.4	14	2	1142.0	1815.0	--	
		7	411842.0	62.8	14	1	1827.0	--	--	
		8	602753.0	95.9	14	3	1517.0	1977.0	1856.0	
		9	834.0	57.3	14	1	1650.0	--	--	
		10	194205.0	66.8	14	2	1372.0	1319.0	--	
		11	367356.0	78.0	14	2	1252.0	1895.0	--	
		12	579368.0	88.5	14	3	1916.0	1398.0	1549.0	
		13	774013.0	82.9	14	2	1299.0	1712.0	--	
		14	170693.0	55.0	14	1	1256.0	--	--	

Type 5 Radar Waveform_1

Download	1	Type 5	17	0.7058824	12.0000000	5.510000000				
		Burst ID	Burst Offset (us)	Pulse Width (us)	Chirp Width (MHz)	Number of Pulses per Burst	PRI-1 (us)	PRI-2 (us)	PRI-3 (us)	
		0	320493.0	99.9	16	3	1010.0	1226.0	1170.0	
		1	469725.0	94.4	16	3	1863.0	1929.0	1246.0	
		2	660082.0	91.5	16	3	1969.0	1109.0	1557.0	
		3	128984.0	94.7	16	3	1215.0	1703.0	1307.0	
		4	299689.0	69.7	16	2	1043.0	1936.0	--	
		5	471217.0	56.5	16	1	1407.0	--	--	
		6	639783.0	90.0	16	3	1265.0	1333.0	1323.0	
		7	107971.0	100.0	16	3	1050.0	1851.0	1656.0	
		8	279337.0	60.1	16	1	1347.0	--	--	
		9	448071.0	99.7	16	3	1647.0	1809.0	1238.0	
		10	617942.0	89.0	16	3	1831.0	1858.0	1220.0	
		11	87422.0	55.4	16	1	1313.0	--	--	
		12	257468.0	80.7	16	2	1665.0	1923.0	--	
		13	427048.0	85.3	16	3	1701.0	1369.0	1748.0	
		14	599578.0	59.0	16	1	1882.0	--	--	
		15	66340.0	65.9	16	1	1672.0	--	--	
		16	236010.0	89.0	16	3	1324.0	1822.0	1860.0	

Type 5 Radar Waveform_2

Download	2	Type 5	8	1.5000000	12.0000000	5.510000000				
		Burst ID	Burst Offset (us)	Pulse Width (us)	Chirp Width (MHz)	Number of Pulses per Burst	PRI-1 (us)	PRI-2 (us)	PRI-3 (us)	
		0	868084.0	64.9	6	1	1408.0	--	--	
		1	1231531.0	62.1	6	1	1420.0	--	--	
		2	96389.0	57.2	6	1	1641.0	--	--	
		3	459519.0	68.1	6	2	1200.0	1318.0	--	
		4	822431.0	80.7	6	2	1276.0	1741.0	--	
		5	1186578.0	55.1	6	1	1651.0	--	--	
		6	51552.0	89.0	6	3	1065.0	1479.0	1249.0	
		7	414067.0	88.4	6	3	1602.0	1918.0	1581.0	

Type 5 Radar Waveform_3

Download	3	Type 5	9	1.3333333	12.0000000	5.510000000				
		Burst ID	Burst Offset (us)	Pulse Width (us)	Chirp Width (MHz)	Number of Pulses per Burst	PRI-1 (us)	PRI-2 (us)	PRI-3 (us)	
		0	691007.0	82.3	7	2	1363.0	1878.0	--	
		1	1013023.0	97.7	7	3	1351.0	1643.0	1000.0	
		2	6103.0	64.3	7	1	1049.0	--	--	
		3	328385.0	93.9	7	3	1894.0	1294.0	1255.0	
		4	650475.0	88.9	7	3	1940.0	1550.0	1379.0	
		5	973948.0	67.1	7	2	1527.0	1595.0	--	
		6	1297299.0	71.3	7	2	1262.0	1108.0	--	
		7	288570.0	91.7	7	3	1483.0	1993.0	1501.0	
		8	612447.0	66.3	7	1	1259.0	--	--	

Type 5 Radar Waveform_4

Download	4	Type 5	20	0.6000000	12.0000000	5.510000000				
		Burst ID	Burst Offset (us)	Pulse Width (us)	Chirp Width (MHz)	Number of Pulses per Burst	PRI-1 (us)	PRI-2 (us)	PRI-3 (us)	
		0	418939.0	76.8	19	2	1922.0	1555.0	-	
		1	565445.0	55.6	19	1	1540.0	-	-	
		2	111782.0	80.5	19	2	1481.0	1917.0	-	
		3	257141.0	55.6	19	1	1853.0	-	-	
		4	402485.0	54.5	19	1	1444.0	-	-	
		5	545218.0	94.4	19	3	1452.0	1508.0	1146.0	
		6	93815.0	88.9	19	3	1554.0	1309.0	1448.0	
		7	238350.0	86.1	19	3	1866.0	1179.0	1111.0	
		8	382582.0	93.2	19	3	1612.0	1781.0	1198.0	
		9	529605.0	57.6	19	1	1633.0	-	-	
		10	76316.0	57.8	19	1	1861.0	-	-	
		11	220529.0	85.0	19	3	1941.0	1214.0	1056.0	
		12	364841.0	89.7	19	3	1824.0	1019.0	1872.0	
		13	510265.0	77.6	19	2	1354.0	1991.0	-	
		14	58201.0	86.9	19	3	1575.0	1756.0	1209.0	
		15	202659.0	91.4	19	3	1798.0	1103.0	1521.0	
		16	347970.0	77.8	19	2	1134.0	1805.0	-	
		17	494019.0	63.0	19	1	1432.0	-	-	
		18	40520.0	76.3	19	2	1857.0	1286.0	-	
		19	185289.0	75.7	19	2	1816.0	1244.0	-	

Type 5 Radar Waveform_5

Download	5	Type 5	18	0.6666667	12.0000000	5.510000000				
		Burst ID	Burst Offset (us)	Pulse Width (us)	Chirp Width (MHz)	Number of Pulses per Burst	PRI-1 (us)	PRI-2 (us)	PRI-3 (us)	
		0	366638.0	86.9	17	3	1304.0	1133.0	1148.0	
		1	527558.0	69.2	17	2	1914.0	1542.0	-	
		2	25150.0	89.2	17	3	1829.0	1601.0	1267.0	
		3	186704.0	52.4	17	1	1112.0	-	-	
		4	347764.0	56.3	17	1	1797.0	-	-	
		5	507025.0	87.4	17	3	1073.0	1686.0	1638.0	
		6	5404.0	58.8	17	1	1045.0	-	-	
		7	166169.0	75.6	17	2	1905.0	1808.0	-	
		8	328052.0	56.1	17	1	1492.0	-	-	
		9	488898.0	71.3	17	2	1068.0	1076.0	-	
		10	649160.0	82.5	17	2	1592.0	1478.0	-	
		11	146469.0	67.6	17	2	1740.0	1497.0	-	
		12	308225.0	63.7	17	1	1395.0	-	-	
		13	469711.0	64.4	17	1	1201.0	-	-	
		14	631070.0	58.4	17	1	1241.0	-	-	
		15	126929.0	53.4	17	1	1772.0	-	-	
		16	288965.0	85.5	17	3	1495.0	1380.0	1717.0	
		17	447231.0	83.4	17	3	1992.0	1212.0	1843.0	

Type 5 Radar Waveform_6

Download	6	Type 5	13	0.9230769	12.0000000	5.510000000				
		Burst ID	Burst Offset (us)	Pulse Width (us)	Chirp Width (MHz)	Number of Pulses per Burst	PRI-1 (us)	PRI-2 (us)	PRI-3 (us)	
		0	846151.0	60.4	11	1	1841.0	-	-	
		1	148160.0	67.8	11	2	1222.0	1757.0	-	
		2	371494.0	68.3	11	2	1254.0	1275.0	-	
		3	594756.0	82.1	11	2	1499.0	1030.0	-	
		4	816486.0	87.5	11	3	1047.0	1865.0	1341.0	
		5	120518.0	97.5	11	3	1247.0	1733.0	1176.0	
		6	343903.0	81.1	11	2	1228.0	1543.0	-	
		7	567787.0	53.4	11	1	1666.0	-	-	
		8	788520.0	92.7	11	3	1663.0	1417.0	1775.0	
		9	93193.0	70.1	11	2	1505.0	1400.0	-	
		10	316461.0	77.5	11	2	1279.0	1342.0	-	
		11	540095.0	52.4	11	1	1948.0	-	-	
		12	763479.0	61.0	11	1	1971.0	-	-	

Type 5 Radar Waveform_7

Download	7	Type 5	11	1.0909091	12.0000000	5.510000000				
		Burst ID	Burst Offset (us)	Pulse Width (us)	Chirp Width (MHz)	Number of Pulses per Burst	PRI-1 (us)	PRI-2 (us)	PRI-3 (us)	
		0	77759.0	54.1	9	1	1901.0	-	-	
		1	340992.0	95.1	9	3	1835.0	1062.0	1825.0	
		2	606443.0	66.0	9	1	1099.0	-	-	
		3	869308.0	79.4	9	2	1574.0	1338.0	-	
		4	45244.0	57.5	9	1	1456.0	-	-	
		5	309468.0	66.4	9	1	1467.0	-	-	
		6	573318.0	78.1	9	2	1023.0	1154.0	-	
		7	835335.0	99.4	9	3	1714.0	1113.0	1996.0	
		8	12685.0	67.1	9	2	1292.0	1171.0	-	
		9	276177.0	85.5	9	3	1204.0	1742.0	1449.0	
		10	541105.0	63.2	9	1	1548.0	-	-	

Type 5 Radar Waveform_8

Download	8	Type 5	19	0.6315789	12.0000000	5.510000000				
		Burst ID	Burst Offset (us)	Pulse Width (us)	Chirp Width (MHz)	Number of Pulses per Burst	PRI-1 (us)	PRI-2 (us)	PRI-3 (us)	
		0	464564.0	79.9	19	2	1433.0	1719.0	-	
		1	616840.0	71.8	19	2	1357.0	1935.0	-	
		2	141102.0	75.1	19	2	1197.0	1337.0	-	
		3	292927.0	90.3	19	3	1401.0	1532.0	1182.0	
		4	445709.0	71.3	19	2	1513.0	1754.0	-	
		5	598121.0	75.2	19	2	1330.0	1909.0	-	
		6	122235.0	69.1	19	2	1458.0	1463.0	-	
		7	273741.0	83.5	19	3	1422.0	1952.0	1752.0	
		8	428352.0	55.9	19	1	1187.0	-	-	
		9	578078.0	94.5	19	3	1793.0	1287.0	1538.0	
		10	103720.0	52.5	19	1	1303.0	-	-	
		11	256549.0	58.4	19	1	1384.0	-	-	
		12	409157.0	57.3	19	1	1744.0	-	-	
		13	562146.0	54.8	19	1	1482.0	-	-	
		14	84602.0	81.7	19	2	1631.0	1821.0	-	
		15	236451.0	91.8	19	3	1903.0	1635.0	1217.0	
		16	389675.0	71.3	19	2	1523.0	1297.0	-	
		17	543408.0	52.8	19	1	1383.0	-	-	
		18	65720.0	94.8	19	3	1622.0	1006.0	1937.0	

Type 5 Radar Waveform_9

Download	9	Type 5	9	1.3333333	12.0000000	5.510000000				
		Burst ID	Burst Offset (us)	Pulse Width (us)	Chirp Width (MHz)	Number of Pulses per Burst	PRI-1 (us)	PRI-2 (us)	PRI-3 (us)	
		0	461367.0	88.8	7	3	1836.0	1814.0	1419.0	
		1	784602.0	98.1	7	3	1127.0	1086.0	1011.0	
		2	1108379.0	53.7	7	1	1802.0	-	-	
		3	99816.0	60.3	7	1	1394.0	-	-	
		4	422146.0	78.4	7	2	1928.0	1692.0	-	
		5	744958.0	72.6	7	2	1885.0	1174.0	-	
		6	1065665.0	97.7	7	3	1951.0	1998.0	1510.0	
		7	59908.0	85.1	7	3	1697.0	1095.0	1193.0	
		8	383139.0	50.8	7	1	1125.0	-	-	

Type 5 Radar Waveform_10

Download	10	Type 5	12	1.0000000	12.0000000	5.495000000				
		Burst ID	Burst Offset (us)	Pulse Width (us)	Chirp Width (MHz)	Number of Pulses per Burst	PRI-1 (us)	PRI-2 (us)	PRI-3 (us)	
		0	527999.0	87.0	10	3	1130.0	1434.0	1453.0	
		1	771326.0	57.3	10	1	1726.0	-	-	
		2	15110.0	84.0	10	3	1524.0	1967.0	1870.0	
		3	256677.0	93.3	10	3	1649.0	1208.0	1202.0	
		4	498808.0	82.3	10	2	1620.0	1272.0	-	
		5	741796.0	55.1	10	1	1334.0	-	-	
		6	983633.0	52.1	10	1	1709.0	-	-	
		7	227587.0	65.7	10	1	1147.0	-	-	
		8	468822.0	72.4	10	2	1673.0	1640.0	-	
		9	709643.0	90.9	10	3	1737.0	1790.0	1057.0	
		10	952683.0	82.2	10	2	1186.0	1704.0	-	
		11	197365.0	67.4	10	2	1169.0	1911.0	-	

Type 5 Radar Waveform_11

Download	11	Type 5	15	0.8000000	12.0000000	5.496000000				
		Burst ID	Burst Offset (us)	Pulse Width (us)	Chirp Width (MHz)	Number of Pulses per Burst	PRI-1 (us)	PRI-2 (us)	PRI-3 (us)	
		0	351790.0	51.0	13	1	1396.0	--	--	
		1	543401.0	94.1	13	3	1402.0	1145.0	1888.0	
		2	735697.0	96.5	13	3	1982.0	1945.0	1213.0	
		3	134174.0	86.6	13	1	1819.0	--	--	
		4	328005.0	51.5	13	1	1219.0	--	--	
		5	519305.0	86.6	13	3	1361.0	1850.0	1727.0	
		6	714961.0	58.6	13	1	1780.0	--	--	
		7	110092.0	74.5	13	2	1743.0	1796.0	--	
		8	303702.0	75.8	13	2	1283.0	1091.0	--	
		9	496642.0	74.7	13	2	1531.0	1660.0	--	
		10	690933.0	56.7	13	1	1990.0	--	--	
		11	86248.0	96.6	13	3	1545.0	1424.0	1032.0	
		12	279633.0	72.3	13	2	1684.0	1377.0	--	
		13	471872.0	96.8	13	3	1520.0	1608.0	1691.0	
		14	667710.0	65.2	13	1	1253.0	--	--	

Type 5 Radar Waveform_12

Download	12	Type 5	17	0.7058824	12.0000000	5.498000000				
		Burst ID	Burst Offset (us)	Pulse Width (us)	Chirp Width (MHz)	Number of Pulses per Burst	PRI-1 (us)	PRI-2 (us)	PRI-3 (us)	
		0	55177.0	76.2	17	2	1059.0	1734.0	--	
		1	228067.0	61.5	17	1	1644.0	--	--	
		2	395221.0	96.7	17	3	1892.0	1143.0	1530.0	
		3	566697.0	67.7	17	2	1707.0	1140.0	--	
		4	34192.0	73.6	17	2	1063.0	1316.0	--	
		5	204023.0	90.2	17	3	1613.0	1504.0	1980.0	
		6	374865.0	68.2	17	2	1498.0	1950.0	--	
		7	544834.0	96.5	17	3	1514.0	1089.0	1352.0	
		8	13130.0	98.7	17	3	1755.0	1794.0	1289.0	
		9	183948.0	60.5	17	1	1804.0	--	--	
		10	354710.0	59.2	17	1	1801.0	--	--	
		11	524676.0	76.2	17	2	1770.0	1098.0	--	
		12	696782.0	52.2	17	1	1268.0	--	--	
		13	162875.0	52.7	17	1	1972.0	--	--	
		14	333694.0	66.0	17	1	1763.0	--	--	
		15	503802.0	69.3	17	2	1025.0	1664.0	--	
		16	674024.0	80.5	17	2	1221.0	1807.0	--	

Type 5 Radar Waveform_13

Download	13	Type 5	16	0.7500000	12.0000000	5.497000000				
		Burst ID	Burst Offset (us)	Pulse Width (us)	Chirp Width (MHz)	Number of Pulses per Burst	PRI-1 (us)	PRI-2 (us)	PRI-3 (us)	
		0	150487.0	70.7	15	2	1720.0	1489.0	--	
		1	331855.0	77.4	15	2	1597.0	1054.0	--	
		2	511873.0	87.7	15	3	1496.0	1431.0	1526.0	
		3	695577.0	54.0	15	1	1348.0	--	--	
		4	128551.0	57.2	15	1	1027.0	--	--	
		5	308609.0	93.7	15	3	1634.0	1500.0	1736.0	
		6	490434.0	76.9	15	2	1346.0	1838.0	--	
		7	671016.0	86.0	15	3	1008.0	1753.0	1028.0	
		8	105569.0	89.0	15	3	1535.0	1787.0	1989.0	
		9	287820.0	60.6	15	1	1042.0	--	--	
		10	468251.0	75.1	15	2	1378.0	1603.0	--	
		11	650692.0	62.3	15	1	1525.0	--	--	
		12	83769.0	50.6	15	1	1315.0	--	--	
		13	264394.0	87.5	15	3	1457.0	1090.0	1462.0	
		14	446147.0	71.0	15	2	1195.0	1429.0	--	
		15	625338.0	85.5	15	3	1516.0	1852.0	1723.0	

Type 5 Radar Waveform_14

Download	14	Type 5	9	1.3333333	12.0000000	5.494000000				
		Burst ID	Burst Offset (us)	Pulse Width (us)	Chirp Width (MHz)	Number of Pulses per Burst	PRI-1 (us)	PRI-2 (us)	PRI-3 (us)	
		0	108974.0	89.9	6	3	1579.0	1404.0	1618.0	
		1	431589.0	75.9	6	2	1632.0	1874.0	-	
		2	755141.0	54.1	6	1	1696.0	-	-	
		3	1076557.0	75.7	6	2	1994.0	1614.0	-	
		4	69362.0	73.2	6	2	1987.0	1018.0	-	
		5	392591.0	58.6	6	1	1031.0	-	-	
		6	715102.0	77.2	6	2	1136.0	1039.0	-	
		7	1037595.0	82.8	6	2	1610.0	1020.0	-	
		8	29583.0	97.6	6	3	1491.0	1566.0	1589.0	

Type 5 Radar Waveform_15

Download	15	Type 5	20	0.6000000	12.0000000	5.499000000				
		Burst ID	Burst Offset (us)	Pulse Width (us)	Chirp Width (MHz)	Number of Pulses per Burst	PRI-1 (us)	PRI-2 (us)	PRI-3 (us)	
		0	157846.0	97.9	20	3	1037.0	1854.0	1005.0	
		1	303542.0	56.1	20	1	1685.0	-	-	
		2	447115.0	92.3	20	3	1317.0	1141.0	1277.0	
		3	594322.0	60.4	20	1	1121.0	-	-	
		4	140525.0	56.4	20	1	1823.0	-	-	
		5	284955.0	71.7	20	2	1943.0	1236.0	-	
		6	430921.0	59.8	20	1	1467.0	-	-	
		7	575845.0	55.3	20	1	1730.0	-	-	
		8	122557.0	76.3	20	2	1233.0	1071.0	-	
		9	267206.0	75.8	20	2	1840.0	1158.0	-	
		10	410352.0	95.0	20	3	1834.0	1680.0	1869.0	
		11	557974.0	59.1	20	1	1728.0	-	-	
		12	104811.0	61.1	20	1	1677.0	-	-	
		13	249556.0	68.9	20	2	1097.0	1459.0	-	
		14	394673.0	67.8	20	2	1007.0	1218.0	-	
		15	538860.0	69.8	20	2	1771.0	1332.0	-	
		16	86686.0	81.7	20	2	1605.0	1795.0	-	
		17	230965.0	84.6	20	3	1533.0	1493.0	1443.0	
		18	376566.0	79.6	20	2	1084.0	1536.0	-	
		19	519535.0	93.2	20	3	1260.0	1883.0	1670.0	

Type 5 Radar Waveform_16

Download	16	Type 5	19	0.6315789	12.0000000	5.499000000				
		Burst ID	Burst Offset (us)	Pulse Width (us)	Chirp Width (MHz)	Number of Pulses per Burst	PRI-1 (us)	PRI-2 (us)	PRI-3 (us)	
		0	72364.0	84.1	19	3	1944.0	1336.0	1366.0	
		1	224519.0	96.1	19	3	1721.0	1512.0	1123.0	
		2	377637.0	73.0	19	2	1410.0	1285.0	-	
		3	529100.0	86.3	19	3	1258.0	1472.0	1224.0	
		4	53696.0	90.7	19	3	1345.0	1235.0	1355.0	
		5	206687.0	62.3	19	1	1593.0	-	-	
		6	358555.0	76.8	19	2	1590.0	1621.0	-	
		7	512168.0	61.9	19	1	1718.0	-	-	
		8	34943.0	93.7	19	3	1764.0	1069.0	1139.0	
		9	187779.0	57.3	19	1	1886.0	-	-	
		10	340852.0	62.0	19	1	1234.0	-	-	
		11	493663.0	50.1	19	1	1321.0	-	-	
		12	16250.0	54.8	19	1	1782.0	-	-	
		13	169021.0	56.4	19	1	1688.0	-	-	
		14	321760.0	59.4	19	1	1745.0	-	-	
		15	471390.0	87.6	19	3	2000.0	1933.0	1959.0	
		16	624130.0	84.6	19	3	1964.0	1662.0	1271.0	
		17	149798.0	75.6	19	2	1786.0	1600.0	-	
		18	302593.0	82.6	19	2	1427.0	1048.0	-	

Type 5 Radar Waveform_17

Download	17	Type 5	18	0.6886867	12.0000000	5.498000000				
		Burst ID	Burst Offset (us)	Pulse Width (us)	Chirp Width (MHz)	Number of Pulses per Burst	PRI-1 (us)	PRI-2 (us)	PRI-3 (us)	
		0	479176.0	88.9	18	3	1588.0	1412.0	1385.0	
		1	642631.0	65.2	18	1	1454.0	-	-	
		2	138786.0	57.0	18	1	1300.0	-	-	
		3	299055.0	74.3	18	2	1983.0	1761.0	-	
		4	461210.0	61.6	18	1	1762.0	-	-	
		5	620750.0	76.0	18	2	1820.0	1779.0	-	
		6	118673.0	76.4	18	2	1115.0	1502.0	-	
		7	279391.0	78.8	18	2	1729.0	1683.0	-	
		8	441543.0	56.9	18	1	1465.0	-	-	
		9	600258.0	86.4	18	3	1206.0	1322.0	1826.0	
		10	98945.0	55.8	18	1	1875.0	-	-	
		11	259259.0	91.6	18	3	1207.0	1329.0	1687.0	
		12	420532.0	74.0	18	2	1562.0	1700.0	-	
		13	580873.0	97.7	18	3	1237.0	1153.0	1506.0	
		14	78785.0	89.7	18	3	1451.0	1409.0	1537.0	
		15	240385.0	63.4	18	1	1746.0	-	-	
		16	400002.0	99.9	18	3	1585.0	1382.0	1473.0	
		17	561316.0	83.1	18	2	1979.0	1630.0	-	

Type 5 Radar Waveform_18

Download	18	Type 5	19	0.6315789	12.0000000	5.499000000				
		Burst ID	Burst Offset (us)	Pulse Width (us)	Chirp Width (MHz)	Number of Pulses per Burst	PRI-1 (us)	PRI-2 (us)	PRI-3 (us)	
		0	56155.0	53.9	19	1	1250.0	-	-	
		1	208695.0	69.7	19	2	1205.0	1052.0	-	
		2	360416.0	94.1	19	3	1150.0	1075.0	1616.0	
		3	512311.0	95.0	19	3	1374.0	1818.0	1079.0	
		4	37117.0	98.0	19	3	1750.0	1114.0	1877.0	
		5	189988.0	61.6	19	1	1949.0	-	-	
		6	342235.0	68.9	19	2	1710.0	1080.0	-	
		7	495704.0	63.8	19	1	1560.0	-	-	
		8	18368.0	94.8	19	3	1837.0	1450.0	1565.0	
		9	171276.0	54.2	19	1	1587.0	-	-	
		10	323863.0	54.7	19	1	1988.0	-	-	
		11	477093.0	59.5	19	1	1282.0	-	-	
		12	627526.0	80.2	19	2	1722.0	1995.0	-	
		13	151582.0	85.2	19	3	1725.0	1900.0	1571.0	
		14	305382.0	56.0	19	1	1311.0	-	-	
		15	458286.0	51.9	19	1	1251.0	-	-	
		16	607965.0	90.8	19	3	1189.0	1360.0	1997.0	
		17	133312.0	77.9	19	2	1539.0	1570.0	-	
		18	285505.0	77.1	19	2	1939.0	1679.0	-	

Type 5 Radar Waveform_19

Download	19	Type 5	13	0.9230769	12.0000000	5.496000000				
		Burst ID	Burst Offset (us)	Pulse Width (us)	Chirp Width (MHz)	Number of Pulses per Burst	PRI-1 (us)	PRI-2 (us)	PRI-3 (us)	
		0	641552.0	73.7	11	2	1104.0	1769.0	-	
		1	866099.0	61.4	11	1	1416.0	-	-	
		2	167980.0	62.3	11	1	1364.0	-	-	
		3	391567.0	64.3	11	1	1263.0	-	-	
		4	613618.0	83.6	11	3	1310.0	1194.0	1034.0	
		5	836528.0	69.8	11	2	1669.0	1986.0	-	
		6	140215.0	75.5	11	2	1362.0	1503.0	-	
		7	362856.0	87.9	11	3	1553.0	1159.0	1519.0	
		8	587607.0	65.7	11	1	1248.0	-	-	
		9	807963.0	88.1	11	3	1766.0	1876.0	1261.0	
		10	112854.0	52.5	11	1	1810.0	-	-	
		11	336585.0	65.2	11	1	1003.0	-	-	
		12	558387.0	93.0	11	3	1486.0	1156.0	1373.0	

Type 5 Radar Waveform_20

Download	20	Type 5	9	1.3333333	12.0000000	5.526000000				
		Burst ID	Burst Offset (us)	Pulse Width (us)	Chirp Width (MHz)	Number of Pulses per Burst	PRI-1 (us)	PRI-2 (us)	PRI-3 (us)	
		0	1132242.0	59.5	7	1	1430.0	-	-	
		1	123401.0	54.5	7	1	1060.0	-	-	
		2	445692.0	80.7	7	2	1681.0	1848.0	-	
		3	769401.0	55.9	7	1	1469.0	-	-	
		4	1089256.0	88.5	7	3	1784.0	1767.0	1776.0	
		5	83349.0	94.0	7	3	1974.0	1777.0	1306.0	
		6	406292.0	67.3	7	2	1388.0	1067.0	-	
		7	727830.0	95.4	7	3	1144.0	1871.0	1708.0	
		8	1052676.0	55.3	7	1	1413.0	-	-	

Type 5 Radar Waveform_21

Download	21	Type 5	18	0.6666667	12.0000000	5.522000000				
		Burst ID	Burst Offset (us)	Pulse Width (us)	Chirp Width (MHz)	Number of Pulses per Burst	PRI-1 (us)	PRI-2 (us)	PRI-3 (us)	
		0	21762.0	97.9	17	3	1365.0	1844.0	1528.0	
		1	182649.0	81.2	17	2	1611.0	1859.0	-	
		2	343700.0	72.2	17	2	1676.0	1399.0	-	
		3	504724.0	74.0	17	2	1832.0	1135.0	-	
		4	1988.0	97.5	17	3	1879.0	1281.0	1196.0	
		5	163396.0	56.1	17	1	1191.0	-	-	
		6	323981.0	70.6	17	2	1035.0	1824.0	-	
		7	483107.0	85.5	17	3	1735.0	1898.0	1783.0	
		8	645998.0	72.0	17	2	1471.0	1359.0	-	
		9	143532.0	56.9	17	1	1117.0	-	-	
		10	304730.0	61.8	17	1	1594.0	-	-	
		11	464070.0	86.4	17	3	1257.0	1488.0	1648.0	
		12	626199.0	76.2	17	2	1172.0	1623.0	-	
		13	123311.0	71.6	17	2	1231.0	1705.0	-	
		14	283868.0	91.7	17	3	1393.0	1298.0	1223.0	
		15	446206.0	55.4	17	1	1529.0	-	-	
		16	607185.0	60.4	17	1	1899.0	-	-	
		17	103407.0	75.1	17	2	1639.0	1778.0	-	

Type 5 Radar Waveform_22

Download	22	Type 5	20	0.6000000	12.0000000	5.521000000				
		Burst ID	Burst Offset (us)	Pulse Width (us)	Chirp Width (MHz)	Number of Pulses per Burst	PRI-1 (us)	PRI-2 (us)	PRI-3 (us)	
		0	237938.0	72.4	20	2	1440.0	1389.0	-	
		1	382364.0	73.8	20	2	1789.0	1674.0	-	
		2	529205.0	53.1	20	1	1016.0	-	-	
		3	75226.0	75.7	20	2	1173.0	1961.0	-	
		4	219559.0	92.3	20	3	1232.0	1975.0	1083.0	
		5	363683.0	89.0	20	3	1439.0	1887.0	1544.0	
		6	510652.0	61.8	20	1	1788.0	-	-	
		7	57592.0	50.0	20	1	1092.0	-	-	
		8	202256.0	75.7	20	2	1609.0	1225.0	-	
		9	347592.0	54.5	20	1	1966.0	-	-	
		10	493000.0	50.0	20	1	1522.0	-	-	
		11	39699.0	63.4	20	1	1110.0	-	-	
		12	183920.0	96.9	20	3	1192.0	1328.0	1921.0	
		13	329752.0	60.5	20	1	1919.0	-	-	
		14	474008.0	81.7	20	2	1131.0	1792.0	-	
		15	21714.0	68.3	20	2	1912.0	1768.0	-	
		16	166934.0	63.6	20	1	1551.0	-	-	
		17	311362.0	81.1	20	2	1122.0	1799.0	-	
		18	454613.0	92.1	20	3	1475.0	1812.0	1675.0	
		19	3916.0	59.6	20	1	1128.0	-	-	

Type 5 Radar Waveform_23

Download	23	Type 5	10	1.2000000	12.0000000	5.528000000				
		Burst ID	Burst Offset (us)	Pulse Width (us)	Chirp Width (MHz)	Number of Pulses per Burst	PRI-1 (us)	PRI-2 (us)	PRI-3 (us)	
		0	298132.0	72.4	8	2	1455.0	1561.0	-	
		1	588557.0	69.4	8	2	1558.0	1216.0	-	
		2	878680.0	67.2	8	2	1927.0	1178.0	-	
		3	1169160.0	80.3	8	2	1811.0	1093.0	-	
		4	262775.0	66.0	8	1	1181.0	-	-	
		5	552237.0	95.7	8	3	1698.0	1149.0	1126.0	
		6	844367.0	53.4	8	1	1055.0	-	-	
		7	1135049.0	56.6	8	1	1161.0	-	-	
		8	226590.0	83.3	8	2	1839.0	1302.0	-	
		9	516846.0	83.0	8	2	1791.0	1397.0	-	

Type 5 Radar Waveform_24

Download	24	Type 5	20	0.6000000	12.0000000	5.521000000				
		Burst ID	Burst Offset (us)	Pulse Width (us)	Chirp Width (MHz)	Number of Pulses per Burst	PRI-1 (us)	PRI-2 (us)	PRI-3 (us)	
		0	401820.0	89.0	20	3	1654.0	1155.0	1358.0	
		1	548401.0	50.5	20	1	1907.0	-	-	
		2	95181.0	78.1	20	2	1058.0	2000.0	-	
		3	240301.0	68.8	20	2	1038.0	1167.0	-	
		4	384243.0	95.0	20	3	1017.0	1320.0	1455.0	
		5	529501.0	71.6	20	2	1668.0	1403.0	-	
		6	77525.0	52.1	20	1	1689.0	-	-	
		7	222238.0	72.1	20	2	1327.0	1425.0	-	
		8	365443.0	89.0	20	3	1552.0	1999.0	1881.0	
		9	512181.0	83.2	20	2	1391.0	1081.0	-	
		10	59632.0	62.2	20	1	1873.0	-	-	
		11	203660.0	97.5	20	3	1890.0	1051.0	1962.0	
		12	349489.0	80.4	20	2	1163.0	1175.0	-	
		13	495538.0	66.0	20	1	1012.0	-	-	
		14	41635.0	85.5	20	3	1368.0	1053.0	1293.0	
		15	187052.0	58.5	20	1	1157.0	-	-	
		16	331980.0	60.1	20	1	1716.0	-	-	
		17	476884.0	51.2	20	1	1965.0	-	-	
		18	23915.0	54.6	20	1	1371.0	-	-	
		19	169095.0	57.9	20	1	1392.0	-	-	

Type 5 Radar Waveform_25

Download	25	Type 5	18	0.6666667	12.0000000	5.522000000				
		Burst ID	Burst Offset (us)	Pulse Width (us)	Chirp Width (MHz)	Number of Pulses per Burst	PRI-1 (us)	PRI-2 (us)	PRI-3 (us)	
		0	349356.0	57.9	17	1	1243.0	-	-	
		1	510776.0	60.5	17	1	1199.0	-	-	
		2	6704.0	63.3	17	1	1278.0	-	-	
		3	168011.0	50.8	17	1	1559.0	-	-	
		4	329307.0	52.6	17	1	1586.0	-	-	
		5	490892.0	52.9	17	1	1203.0	-	-	
		6	651799.0	56.5	17	1	1702.0	-	-	
		7	147887.0	72.9	17	2	1188.0	1511.0	-	
		8	309316.0	59.6	17	1	1849.0	-	-	
		9	468355.0	96.7	17	3	1978.0	1541.0	1438.0	
		10	629706.0	85.6	17	3	1653.0	1119.0	1274.0	
		11	128246.0	55.2	17	1	1690.0	-	-	
		12	289150.0	66.7	17	2	1269.0	1280.0	-	
		13	449136.0	92.8	17	3	1242.0	1445.0	1460.0	
		14	612450.0	65.5	17	1	1288.0	-	-	
		15	107869.0	99.6	17	3	1515.0	1954.0	1356.0	
		16	268574.0	85.4	17	3	1447.0	1100.0	1817.0	
		17	430071.0	78.0	17	2	1040.0	1985.0	-	

Type 5 Radar Waveform_26

Download	26	Type 5	9	1.3333333	12.0000000	5.526000000				
		Burst ID	Burst Offset (us)	Pulse Width (us)	Chirp Width (MHz)	Number of Pulses per Burst	PRI-1 (us)	PRI-2 (us)	PRI-3 (us)	
		0	1186199.0	65.5	6	1	1390.0	-	-	
		1	177344.0	60.1	6	1	1013.0	-	-	
		2	500300.0	66.1	6	1	1476.0	-	-	
		3	821660.0	91.6	6	3	1001.0	1381.0	1774.0	
		4	1143652.0	92.1	6	3	1567.0	1120.0	1906.0	
		5	137508.0	58.9	6	1	1343.0	-	-	
		6	459407.0	97.4	6	3	1904.0	1418.0	1349.0	
		7	783119.0	75.0	6	2	1151.0	1021.0	-	
		8	1103375.0	89.1	6	3	1428.0	1908.0	1957.0	

Type 5 Radar Waveform_27

Download	27	Type 5	15	0.8000000	12.0000000	5.523000000				
		Burst ID	Burst Offset (us)	Pulse Width (us)	Chirp Width (MHz)	Number of Pulses per Burst	PRI-1 (us)	PRI-2 (us)	PRI-3 (us)	
		0	58593.0	51.1	14	1	1301.0	-	-	
		1	250925.0	94.9	14	3	1934.0	1785.0	1942.0	
		2	446169.0	57.4	14	1	1022.0	-	-	
		3	637717.0	65.5	14	3	1072.0	1655.0	1078.0	
		4	34733.0	52.2	14	1	1296.0	-	-	
		5	228395.0	51.9	14	1	1466.0	-	-	
		6	421096.0	75.4	14	2	1629.0	1671.0	-	
		7	614419.0	75.0	14	2	1227.0	1946.0	-	
		8	10845.0	78.5	14	2	1731.0	1564.0	-	
		9	203538.0	87.2	14	3	1891.0	1803.0	1682.0	
		10	397245.0	77.2	14	2	1627.0	1773.0	-	
		11	591676.0	66.1	14	1	1739.0	-	-	
		12	781344.0	92.1	14	3	1833.0	1968.0	1938.0	
		13	180698.0	65.1	14	1	1405.0	-	-	
		14	373813.0	79.3	14	2	1615.0	1004.0	-	

Type 5 Radar Waveform_28

Download	28	Type 5	17	0.7058824	12.0000000	5.522000000				
		Burst ID	Burst Offset (us)	Pulse Width (us)	Chirp Width (MHz)	Number of Pulses per Burst	PRI-1 (us)	PRI-2 (us)	PRI-3 (us)	
		0	500961.0	62.4	16	1	1625.0	-	-	
		1	669226.0	92.4	16	3	1435.0	1765.0	1068.0	
		2	137709.0	97.7	16	3	1546.0	1846.0	1308.0	
		3	309227.0	57.0	16	1	1376.0	-	-	
		4	479042.0	80.7	16	2	1902.0	1015.0	-	
		5	647469.0	87.7	16	3	1915.0	1637.0	1599.0	
		6	117367.0	50.5	16	1	1064.0	-	-	
		7	286909.0	85.9	16	3	1509.0	1129.0	1845.0	
		8	458518.0	73.1	16	2	1160.0	1024.0	-	
		9	628991.0	82.1	16	2	1375.0	1029.0	-	
		10	95885.0	65.7	16	3	1312.0	1760.0	1107.0	
		11	265912.0	94.6	16	3	1138.0	1490.0	1970.0	
		12	435837.0	91.9	16	3	1572.0	1387.0	1693.0	
		13	608589.0	66.4	16	1	1693.0	-	-	
		14	74999.0	68.4	16	2	1480.0	1984.0	-	
		15	245916.0	54.4	16	1	1864.0	-	-	
		16	416752.0	53.5	16	1	1713.0	-	-	

Type 5 Radar Waveform_29

Download	29	Type 5	10	1.2000000	12.0000000	5.526000000				
		Burst ID	Burst Offset (us)	Pulse Width (us)	Chirp Width (MHz)	Number of Pulses per Burst	PRI-1 (us)	PRI-2 (us)	PRI-3 (us)	
		0	998753.0	77.7	7	2	1556.0	1423.0	-	
		1	92174.0	63.9	7	1	1335.0	-	-	
		2	382943.0	55.3	7	1	1162.0	-	-	
		3	672584.0	78.1	7	2	1569.0	1577.0	-	
		4	964443.0	52.1	7	1	1177.0	-	-	
		5	56379.0	61.1	7	1	1033.0	-	-	
		6	346299.0	83.4	7	3	1461.0	1101.0	1464.0	
		7	637595.0	53.2	7	1	1706.0	-	-	
		8	925578.0	91.3	7	3	1386.0	1868.0	1861.0	
		9	20533.0	67.7	7	2	1474.0	1183.0	-	

Radar Type 6 - Radar Statistical Performance			
Trail #	1=Detection 0=No Detection	Trail #	1=Detection 0=No Detection
0	1	15	1
1	1	16	1
2	1	17	0
3	1	18	1
4	1	19	1
5	1	20	1
6	1	21	1
7	1	22	1
8	1	23	1
9	1	24	1
10	1	25	1
11	1	26	1
12	1	27	1
13	1	28	1
14	1	29	1
Detection Percentage (%)		96.7%	

Type 6 Radar Waveform_0

Download	0	Type 6	1.0	333.3	9	0.3333	300.0000000	9
		Frequency List (MHz)	0	1	2	3	4	
		0	5524	5287	5528	5420	5348	
		5	5369	5644	5608	5351	5304	
		10	5612	5434	5323	5291	5489	
		15	5374	5419	5309	5313	5347	
		20	5437	5330	5532	5267	5654	
		25	5720	5443	5490	5655	5308	
		30	5431	5484	5527	5624	5251	
		35	5495	5322	5686	5667	5389	
		40	5623	5467	5709	5649	5507	
		45	5297	5277	5519	5549	5651	
		50	5541	5675	5343	5500	5512	
		55	5586	5342	5376	5617	5475	
		60	5418	5539	5716	5483	5592	
		65	5666	5371	5271	5358	5661	
		70	5379	5386	5602	5290	5674	
		75	5628	5573	5326	5673	5405	
		80	5625	5696	5554	5497	5672	
		85	5427	5687	5282	5701	5463	
		90	5413	5600	5478	5329	5266	
		95	5352	5576	5393	5688	5265	

Type 6 Radar Waveform_1

Download	1	Type 6	1.0	333.3	9	0.3333	300.0000000	8
		Frequency List (MHz)	0	1	2	3	4	
		0	5304	5526	5464	5581	5568	
		5	5411	5666	5683	5417	5608	
		10	5543	5698	5364	5486	5510	
		15	5365	5449	5315	5261	5539	
		20	5445	5399	5375	5621	5715	
		25	5669	5372	5547	5524	5351	
		30	5544	5265	5646	5258	5347	
		35	5288	5439	5291	5475	5600	
		40	5506	5472	5629	5276	5620	
		45	5396	5689	5257	5565	5350	
		50	5542	5395	5250	5702	5630	
		55	5498	5665	5688	5373	5564	
		60	5483	5507	5724	5443	5478	
		65	5424	5357	5371	5286	5652	
		70	5471	5595	5345	5327	5329	
		75	5521	5631	5353	5671	5348	
		80	5476	5643	5306	5370	5579	
		85	5469	5374	5662	5678	5461	
		90	5569	5391	5718	5518	5609	
		95	5311	5703	5277	5690	5324	

Type 6 Radar Waveform_2

Download	2	Type 6	1.0	333.3	9	0.3333	300.000000	8
		Frequency List (MHz)	0	1	2	3	4	
		0	5462	5290	5400	5267	5410	
		5	5453	5591	5283	5580	5340	
		10	5377	5487	5405	5584	5531	
		15	5576	5418	5306	5256	5565	
		20	5316	5613	5688	5333	5521	
		25	5478	5651	5558	5490	5433	
		30	5697	5386	5545	5330	5530	
		35	5562	5628	5611	5345	5652	
		40	5567	5516	5714	5703	5572	
		45	5526	5403	5429	5271	5426	
		50	5278	5719	5699	5609	5401	
		55	5327	5279	5363	5357	5272	
		60	5672	5669	5612	5366	5373	
		65	5393	5581	5467	5358	5260	
		70	5474	5444	5321	5355	5674	
		75	5485	5375	5502	5311	5509	
		80	5455	5513	5571	5543	5379	
		85	5582	5696	5498	5713	5630	
		90	5717	5352	5684	5398	5354	
		95	5500	5573	5593	5645	5331	

Type 6 Radar Waveform_3

Download	3	Type 6	1.0	333.3	9	0.3333	300.000000	9
		Frequency List (MHz)	0	1	2	3	4	
		0	5717	5529	5336	5428	5630	
		5	5495	5613	5358	5268	5547	
		10	5308	5373	5446	5304	5552	
		15	5541	5703	5521	5351	5448	
		20	5364	5634	5257	5702	5661	
		25	5599	5470	5681	5377	5592	
		30	5532	5419	5654	5601	5659	
		35	5365	5469	5621	5455	5403	
		40	5525	5260	5505	5281	5711	
		45	5632	5423	5584	5456	5694	
		50	5622	5602	5329	5333	5522	
		55	5589	5372	5657	5328	5401	
		60	5362	5444	5667	5467	5534	
		65	5322	5429	5413	5295	5270	
		70	5527	5721	5574	5671	5675	
		75	5314	5643	5605	5518	5483	
		80	5563	5619	5302	5576	5568	
		85	5263	5379	5424	5593	5678	
		90	5490	5392	5517	5690	5432	
		95	5512	5374	5628	5577	5679	

Type 6 Radar Waveform_4

Download	4	Type 6	1.0	333.3	9	0.3333	300.0000000	12
		Frequency List (MHz)	0	1	2	3	4	
		0	5497	5293	5272	5589	5472	
		5	5634	5538	5433	5431	5376	
		10	5714	5637	5487	5499	5573	
		15	5629	5355	5624	5396	5262	
		20	5372	5325	5295	5694	5322	
		25	5409	5481	5626	5574	5308	
		30	5611	5719	5336	5563	5608	
		35	5712	5251	5556	5439	5498	
		40	5343	5443	5521	5708	5464	
		45	5532	5506	5642	5509	5581	
		50	5401	5303	5380	5519	5345	
		55	5400	5302	5710	5562	5476	
		60	5299	5530	5527	5656	5276	
		65	5493	5413	5260	5271	5368	
		70	5720	5565	5548	5599	5707	
		75	5577	5520	5651	5273	5515	
		80	5628	5661	5340	5632	5558	
		85	5686	5639	5555	5282	5266	
		90	5310	5546	5635	5263	5590	
		95	5682	5696	5369	5496	5621	

Type 6 Radar Waveform_5

Download	5	Type 6	1.0	333.3	9	0.3333	300.0000000	8
		Frequency List (MHz)	0	1	2	3	4	
		0	5277	5532	5683	5275	5692	
		5	5676	5560	5508	5497	5583	
		10	5548	5426	5528	5694	5594	
		15	5620	5482	5252	5344	5454	
		20	5380	5394	5711	5308	5607	
		25	5375	5649	5612	5585	5660	
		30	5713	5294	5568	5459	5383	
		35	5650	5328	5522	5709	5353	
		40	5434	5523	5381	5664	5705	
		45	5393	5512	5589	5603	5562	
		50	5371	5479	5431	5608	5643	
		55	5722	5490	5673	5270	5659	
		60	5601	5416	5359	5558	5695	
		65	5404	5455	5360	5351	5293	
		70	5693	5677	5369	5627	5707	
		75	5484	5273	5445	5592	5267	
		80	5339	5324	5680	5304	5502	
		85	5414	5511	5410	5372	5403	
		90	5378	5255	5408	5263	5642	
		95	5475	5485	5640	5691	5700	

Type 6 Radar Waveform_6

Download	6	Type 6	1.0	333.3	9	0.3333	300.0000000	7
		Frequency List (MHz)	0	1	2	3	4	
		0	5532	5296	5619	5436	5437	
		5	5718	5485	5583	5660	5315	
		10	5479	5690	5569	5414	5615	
		15	5708	5512	5258	5389	5646	
		20	5291	5560	5652	5300	5580	
		25	5641	5598	5340	5689	5694	
		30	5280	5658	5525	5674	5262	
		35	5678	5314	5516	5318	5484	
		40	5364	5273	5606	5319	5429	
		45	5702	5322	5492	5672	5661	
		50	5518	5628	5655	5482	5697	
		55	5369	5666	5581	5618	5467	
		60	5313	5382	5643	5717	5402	
		65	5284	5644	5343	5287	5252	
		70	5629	5365	5301	5680	5693	
		75	5603	5453	5393	5375	5426	
		80	5377	5595	5539	5387	5559	
		85	5470	5522	5267	5597	5379	
		90	5640	5608	5537	5330	5636	
		95	5626	5373	5367	5268	5511	

Type 6 Radar Waveform_7

Download	7	Type 6	1.0	333.3	9	0.3333	300.0000000	11
		Frequency List (MHz)	0	1	2	3	4	
		0	5690	5535	5652	5500	5279	
		5	5382	5507	5658	5348	5619	
		10	5410	5479	5707	5512	5636	
		15	5321	5639	5361	5434	5363	
		20	5299	5251	5389	5553	5529	
		25	5450	5543	5318	5253	5322	
		30	5547	5482	5414	5511	5401	
		35	5453	5607	5686	5637	5278	
		40	5587	5689	5257	5669	5629	
		45	5472	5280	5719	5571	5523	
		50	5504	5356	5533	5311	5667	
		55	5513	5294	5572	5657	5590	
		60	5345	5588	5344	5640	5582	
		65	5593	5379	5497	5522	5335	
		70	5437	5287	5683	5542	5579	
		75	5625	5325	5421	5407	5524	
		80	5390	5376	5606	5556	5665	
		85	5563	5364	5327	5314	5722	
		90	5594	5435	5428	5702	5336	
		95	5374	5520	5539	5373	5271	

Type 6 Radar Waveform_8

Download	8	Type 6	1. 0	333. 3	9	0. 3333	300. 0000000	9
		Frequency List (MHz)	0	1	2	3	4	
		0	5470	5299	5588	5661	5499	
		5	5424	5432	5258	5511	5351	
		10	5719	5268	5273	5707	5657	
		15	5409	5291	5464	5382	5555	
		20	5307	5320	5631	5381	5526	
		25	5399	5649	5519	5287	5461	
		30	5533	5439	5532	5663	5696	
		35	5592	5698	5482	5315	5667	
		40	5426	5297	5670	5434	5318	
		45	5558	5355	5363	5680	5624	
		50	5410	5283	5584	5497	5490	
		55	5457	5372	5508	5561	5474	
		60	5712	5651	5466	5294	5308	
		65	5542	5415	5329	5414	5613	
		70	5606	5458	5536	5564	5388	
		75	5301	5500	5632	5295	5513	
		80	5456	5385	5303	5290	5506	
		85	5687	5645	5683	5626	5392	
		90	5342	5408	5402	5556	5428	
		95	5691	5644	5703	5413	5274	

Type 6 Radar Waveform_9

Download	9	Type 6	1. 0	333. 3	9	0. 3333	300. 0000000	6
		Frequency List (MHz)	0	1	2	3	4	
		0	5250	5538	5524	5347	5341	
		5	5466	5454	5333	5577	5558	
		10	5650	5629	5314	5427	5678	
		15	5400	5418	5567	5272	5693	
		20	5486	5572	5470	5499	5683	
		25	5251	5377	5623	5321	5503	
		30	5422	5396	5437	5419	5634	
		35	5278	5565	5362	5477	5511	
		40	5315	5390	5335	5446	5263	
		45	5677	5675	5708	5635	5586	
		50	5313	5304	5670	5480	5562	
		55	5327	5532	5603	5402	5478	
		60	5483	5292	5337	5606	5491	
		65	5354	5539	5684	5416	5259	
		70	5311	5618	5434	5543	5641	
		75	5656	5610	5369	5553	5413	
		80	5459	5673	5453	5620	5350	
		85	5601	5555	5599	5456	5349	
		90	5557	5445	5345	5662	5497	
		95	5573	5639	5682	5252	5508	

Type 6 Radar Waveform_10

Download	10	Type 6	1.0	333.3	9	0.3333	300.0000000	6
		Frequency List (MHz)	0	1	2	3	4	
		0	5505	5302	5460	5508	5561	
		5	5379	5408	5265	5290	5484	
		10	5418	5355	5622	5699	5488	
		15	5545	5670	5472	5464	5701	
		20	5555	5610	5462	5474	5578	
		25	5580	5252	5311	5353	5487	
		30	5589	5714	5298	5405	5646	
		35	5718	5592	5676	5560	5449	
		40	5342	5312	5319	5315	5529	
		45	5321	5255	5562	5510	5409	
		50	5686	5675	5514	5723	5383	
		55	5434	5655	5621	5406	5257	
		60	5567	5520	5690	5283	5332	
		65	5440	5390	5371	5479	5694	
		70	5372	5411	5467	5410	5502	
		75	5301	5278	5447	5330	5623	
		80	5669	5261	5450	5397	5369	
		85	5559	5313	5318	5650	5704	
		90	5644	5722	5451	5544	5606	
		95	5590	5538	5281	5537	5564	

Type 6 Radar Waveform_11

Download	11	Type 6	1.0	333.3	9	0.3333	300.0000000	7
		Frequency List (MHz)	0	1	2	3	4	
		0	5663	5638	5396	5669	5403	
		5	5647	5401	5483	5428	5594	
		10	5415	5682	5342	5720	5576	
		15	5575	5676	5517	5278	5709	
		20	5721	5551	5445	5362	5527	
		25	5308	5356	5389	5684	5297	
		30	5310	5605	5363	5437	5496	
		35	5442	5506	5515	5643	5387	
		40	5582	5309	5723	5295	5612	
		45	5282	5352	5289	5585	5262	
		50	5337	5570	5571	5291	5370	
		55	5440	5377	5386	5257	5485	
		60	5719	5516	5704	5630	5486	
		65	5329	5581	5371	5497	5444	
		70	5328	5414	5316	5461	5482	
		75	5421	5324	5258	5450	5690	
		80	5447	5592	5272	5373	5413	
		85	5388	5604	5477	5367	5412	
		90	5457	5618	5593	5265	5435	
		95	5543	5648	5601	5652	5613	

Type 6 Radar Waveform_12

Download	12	Type 6	1. 0	333. 3	9	0. 3333	300. 0000000	5
		Frequency List (MHz)	0	1	2	3	4	
		0	5443	5402	5332	5355	5623	
		5	5689	5326	5558	5591	5346	
		10	5471	5437	5440	5266	5664	
		15	5702	5304	5465	5470	5620	
		20	5315	5492	5543	5418	5250	
		25	5379	5511	5557	5423	5251	
		30	5661	5267	5345	5515	5257	
		35	5479	5684	5713	5646	5517	
		40	5354	5348	5325	5306	5555	
		45	5275	5695	5340	5264	5714	
		50	5640	5286	5313	5378	5635	
		55	5514	5662	5720	5560	5637	
		60	5422	5410	5551	5342	5650	
		65	5356	5435	5365	5413	5641	
		70	5678	5613	5314	5362	5420	
		75	5451	5541	5467	5409	5359	
		80	5271	5706	5387	5444	5312	
		85	5272	5718	5336	5605	5353	
		90	5577	5463	5350	5686	5252	
		95	5721	5648	5724	5333	5425	

Type 6 Radar Waveform_13

Download	13	Type 6	1. 0	333. 3	9	0. 3333	300. 0000000	7
		Frequency List (MHz)	0	1	2	3	4	
		0	5698	5641	5268	5516	5465	
		5	5256	5348	5633	5657	5533	
		10	5655	5260	5478	5635	5287	
		15	5354	5407	5510	5662	5628	
		20	5481	5530	5632	5391	5328	
		25	5617	5661	5457	5293	5550	
		30	5699	5560	5289	5552	5618	
		35	5300	5509	5324	5431	5668	
		40	5263	5490	5400	5484	5255	
		45	5303	5398	5317	5504	5462	
		50	5364	5564	5458	5361	5375	
		55	5674	5275	5456	5319	5547	
		60	5587	5355	5383	5265	5693	
		65	5557	5384	5401	5623	5685	
		70	5517	5392	5338	5379	5323	
		75	5610	5390	5514	5381	5487	
		80	5543	5344	5604	5650	5299	
		85	5322	5696	5609	5498	5385	
		90	5267	5469	5568	5703	5330	
		95	5706	5404	5666	5694	5642	

Type 6 Radar Waveform_14

Download	14	Type 6	1.0	333.3	9	0.3333	300.0000000	4
		Frequency List (MHz)	0	1	2	3	4	
		0	5478	5405	5679	5580	5685	
		5	5298	5273	5708	5345	5362	
		10	5586	5621	5519	5355	5308	
		15	5268	5481	5510	5555	5379	
		20	5636	5550	5471	5624	5364	
		25	5404	5655	5290	5491	5335	
		30	5536	5656	5300	5441	5275	
		35	5282	5391	5402	5477	5604	
		40	5514	5676	5255	5397	5316	
		45	5613	5386	5359	5370	5392	
		50	5638	5415	5653	5659	5305	
		55	5563	5628	5465	5668	5277	
		60	5690	5566	5639	5380	5333	
		65	5340	5455	5328	5284	5383	
		70	5617	5716	5692	5338	5292	
		75	5684	5371	5291	5365	5707	
		80	5610	5341	5324	5553	5499	
		85	5417	5661	5271	5680	5432	
		90	5572	5321	5353	5373	5280	
		95	5283	5314	5286	5389	5596	

Type 6 Radar Waveform_15

Download	15	Type 6	1.0	333.3	9	0.3333	300.0000000	9
		Frequency List (MHz)	0	1	2	3	4	
		0	5258	5644	5615	5266	5527	
		5	5437	5295	5308	5508	5569	
		10	5517	5410	5657	5550	5329	
		15	5356	5608	5613	5600	5571	
		20	5547	5716	5412	5713	5337	
		25	5670	5507	5548	5394	5525	
		30	5474	5425	5418	5690	5570	
		35	5421	5482	5673	5252	5443	
		40	5597	5614	5495	5720	5593	
		45	5566	5417	5423	5656	5646	
		50	5339	5466	5267	5627	5276	
		55	5582	5655	5472	5639	5330	
		60	5442	5342	5522	5489	5585	
		65	5581	5282	5376	5665	5598	
		70	5562	5451	5369	5620	5565	
		75	5668	5297	5261	5324	5352	
		80	5543	5504	5621	5299	5338	
		85	5519	5553	5341	5322	5609	
		90	5529	5422	5403	5578	5710	
		95	5298	5599	5265	5684	5409	

Type 6 Radar Waveform_16

Download	16	Type 6	1.0	333.3	9	0.3333	300.0000000	8
		Frequency List (MHz)	0	1	2	3	4	
		0	5416	5408	5551	5427	5272	
		5	5479	5695	5383	5671	5301	
		10	5351	5674	5698	5270	5350	
		15	5444	5638	5619	5548	5288	
		20	5555	5310	5353	5705	5558	
		25	5456	5276	5595	5462	5516	
		30	5411	5570	5633	5367	5293	
		35	5463	5573	5469	5405	5282	
		40	5302	5552	5391	5649	5475	
		45	5476	5543	5522	5515	5517	
		50	5356	5305	5571	5464	5536	
		55	5370	5291	5610	5459	5607	
		60	5287	5451	5315	5628	5404	
		65	5706	5497	5490	5365	5620	
		70	5355	5623	5414	5644	5256	
		75	5608	5449	5333	5320	5614	
		80	5402	5358	5335	5714	5280	
		85	5382	5704	5494	5568	5670	
		90	5584	5292	5495	5591	5393	
		95	5379	5719	5348	5407	5504	

Type 6 Radar Waveform_17

Download	17	Type 6	1.0	333.3	9	0.3333	300.0000000	5
		Frequency List (MHz)	0	1	2	3	4	
		0	5671	5647	5487	5588	5589	
		5	5521	5717	5458	5359	5605	
		10	5282	5463	5264	5368	5371	
		15	5435	5290	5722	5593	5480	
		20	5563	5476	5391	5319	5283	
		25	5349	5308	5479	5699	5496	
		30	5558	5300	5527	5373	5616	
		35	5602	5286	5362	5659	5596	
		40	5385	5393	5403	5388	5481	
		45	5553	5257	5436	5529	5333	
		50	5398	5691	5568	5542	5603	
		55	5418	5652	5490	5585	5581	
		60	5297	5707	5574	5655	5351	
		65	5285	5546	5692	5438	5723	
		70	5641	5620	5690	5577	5472	
		75	5513	5314	5572	5724	5658	
		80	5627	5421	5332	5434	5597	
		85	5345	5619	5443	5452	5590	
		90	5326	5377	5428	5448	5363	
		95	5395	5601	5451	5502	5622	

Type 6 Radar Waveform_18

Download	18	Type 6	1.0	333.3	9	0.3333	300.0000000	4
		Frequency List (MHz)	0	1	2	3	4	
		0	5451	5411	5423	5274	5334	
		5	5563	5642	5533	5425	5337	
		10	5688	5252	5305	5392	5523	
		15	5417	5350	5638	5672	5474	
		20	5332	5311	5256	5712	5257	
		25	5585	5328	5530	5697	5664	
		30	5484	5588	5390	5266	5377	
		35	5633	5333	5670	5532	5468	
		40	5331	5643	5482	5410	5340	
		45	5494	5485	5695	5619	5631	
		50	5329	5362	5365	5444	5653	
		55	5404	5455	5620	5462	5590	
		60	5539	5520	5428	5604	5387	
		65	5652	5349	5289	5424	5251	
		70	5490	5596	5649	5449	5592	
		75	5559	5295	5262	5439	5316	
		80	5707	5359	5536	5405	5613	
		85	5327	5573	5691	5716	5617	
		90	5693	5263	5259	5445	5503	
		95	5347	5293	5580	5554	5597	

Type 6 Radar Waveform_19

Download	19	Type 6	1.0	333.3	9	0.3333	300.0000000	5
		Frequency List (MHz)	0	1	2	3	4	
		0	5706	5650	5359	5435	5651	
		5	5702	5664	5608	5588	5544	
		10	5522	5613	5346	5283	5413	
		15	5611	5453	5586	5486	5482	
		20	5711	5273	5400	5704	5600	
		25	5584	5313	5432	5564	5264	
		30	5441	5542	5606	5405	5468	
		35	5429	5371	5648	5269	5408	
		40	5479	5717	5513	5423	5552	
		45	5538	5485	5528	5568	5670	
		50	5720	5627	5684	5456	5398	
		55	5368	5601	5426	5274	5694	
		60	5422	5365	5466	5629	5553	
		65	5326	5447	5458	5410	5351	
		70	5339	5572	5418	5712	5276	
		75	5504	5372	5695	5383	5547	
		80	5446	5262	5378	5708	5624	
		85	5464	5439	5307	5699	5297	
		90	5519	5462	5558	5428	5666	
		95	5560	5623	5692	5612	5546	

Type 6 Radar Waveform_20

Download	20	Type 6	1.0	333.3	9	0.3333	300.0000000	6
		Frequency List (MHz)	0	1	2	3	4	
		0	5389	5414	5295	5596	5396	
		5	5269	5589	5683	5276	5373	
		10	5453	5402	5387	5478	5434	
		15	5699	5671	5556	5631	5678	
		20	5490	5311	5392	5677	5391	
		25	5436	5516	5633	5598	5306	
		30	5539	5398	5446	5316	5329	
		35	5447	5559	5700	5639	5498	
		40	5685	5256	5682	5551	5476	
		45	5646	5493	5506	5610	5591	
		50	5372	5404	5721	5334	5450	
		55	5628	5644	5352	5558	5420	
		60	5397	5403	5317	5351	5666	
		65	5509	5355	5502	5362	5581	
		70	5339	5430	5530	5354	5663	
		75	5451	5567	5290	5357	5370	
		80	5281	5482	5547	5707	5701	
		85	5641	5640	5695	5428	5425	
		90	5635	5578	5712	5637	5472	
		95	5705	5709	5401	5358	5576	

Type 6 Radar Waveform_21

Download	21	Type 6	1.0	333.3	9	0.3333	300.0000000	6
		Frequency List (MHz)	0	1	2	3	4	
		0	5644	5653	5706	5282	5713	
		5	5311	5611	5283	5439	5580	
		10	5287	5666	5428	5673	5455	
		15	5690	5701	5562	5676	5395	
		20	5401	5471	5252	5481	5650	
		25	5279	5385	5719	5262	5632	
		30	5445	5355	5661	5468	5624	
		35	5586	5593	5317	5509	5524	
		40	5339	5620	5316	5473	5575	
		45	5376	5589	5571	5637	5280	
		50	5297	5520	5273	5475	5357	
		55	5306	5714	5368	5532	5482	
		60	5681	5658	5451	5398	5609	
		65	5708	5699	5479	5454	5415	
		70	5427	5526	5259	5477	5416	
		75	5335	5533	5495	5257	5711	
		80	5295	5698	5361	5640	5634	
		85	5391	5503	5629	5485	5457	
		90	5268	5467	5668	5396	5462	
		95	5323	5291	5641	5310	5655	

Type 6 Radar Waveform_22

Download	22	Type 6	1. 0	333. 3	9	0. 3333	300. 0000000	4
		Frequency List (MHz)	0	1	2	3	4	
		0	5424	5417	5642	5346	5458	
		5	5353	5633	5358	5505	5312	
		10	5693	5455	5469	5296	5476	
		15	5303	5665	5721	5587	5409	
		20	5637	5668	5473	5623	5545	
		25	5712	5447	5366	5666	5487	
		30	5414	5401	5717	5444	5250	
		35	5266	5389	5567	5423	5363	
		40	5422	5558	5556	5470	5407	
		45	5356	5672	5629	5697	5524	
		50	5534	5621	5348	5609	5474	
		55	5419	5260	5463	5436	5661	
		60	5647	5626	5490	5415	5379	
		65	5400	5337	5404	5465	5457	
		70	5264	5403	5386	5703	5500	
		75	5559	5316	5310	5605	5513	
		80	5695	5543	5451	5466	5583	
		85	5636	5655	5327	5680	5479	
		90	5610	5723	5477	5302	5394	
		95	5364	5405	5392	5597	5582	

Type 6 Radar Waveform_23

Download	23	Type 6	1. 0	333. 3	9	0. 3333	300. 0000000	7
		Frequency List (MHz)	0	1	2	3	4	
		0	5679	5656	5578	5507	5300	
		5	5492	5558	5433	5688	5616	
		10	5624	5719	5607	5491	5497	
		15	5391	5480	5293	5669	5304	
		20	5417	5706	5562	5596	5661	
		25	5553	5470	5700	5529	5303	
		30	5269	5519	5394	5642	5292	
		35	5454	5660	5720	5337	5299	
		40	5602	5496	5699	5564	5336	
		45	5280	5687	5275	5314	5410	
		50	5322	5399	5698	5297	5266	
		55	5258	5592	5653	5255	5688	
		60	5315	5571	5338	5444	5677	
		65	5349	5373	5358	5296	5692	
		70	5465	5451	5557	5588	5379	
		75	5347	5575	5620	5605	5618	
		80	5294	5467	5518	5446	5318	
		85	5414	5429	5634	5409	5475	
		90	5345	5714	5328	5627	5681	
		95	5461	5355	5659	5500	5604	

Type 6 Radar Waveform_24

Download	24	Type 6	1. 0	333. 3	9	0. 3333	300. 0000000	11
		Frequency List (MHz)	0	1	2	3	4	
		0	5459	5420	5514	5668	5520	
		5	5534	5580	5508	5356	5348	
		10	5458	5605	5648	5686	5518	
		15	5479	5607	5396	5714	5496	
		20	5328	5397	5647	5554	5569	
		25	5699	5513	5281	5671	5259	
		30	5289	5701	5643	5462	5431	
		35	5545	5553	5398	5613	5685	
		40	5337	5464	5561	5316	5363	
		45	5676	5286	5498	5450	5312	
		50	5595	5446	5546	5271	5549	
		55	5659	5347	5502	5516	5629	
		60	5639	5390	5403	5298	5665	
		65	5566	5495	5537	5437	5560	
		70	5355	5306	5544	5265	5273	
		75	5278	5717	5253	5550	5631	
		80	5581	5592	5568	5257	5474	
		85	5524	5301	5588	5657	5673	
		90	5351	5651	5697	5266	5261	
		95	5445	5638	5600	5285	5341	

Type 6 Radar Waveform_25

Download	25	Type 6	1. 0	333. 3	9	0. 3333	300. 0000000	9
		Frequency List (MHz)	0	1	2	3	4	
		0	5617	5659	5450	5354	5362	
		5	5576	5505	5583	5519	5555	
		10	5389	5394	5689	5406	5539	
		15	5470	5259	5499	5284	5688	
		20	5336	5466	5588	5643	5542	
		25	5587	5365	5484	5300	5293	
		30	5710	5653	5658	5474	5320	
		35	5660	5570	5636	5349	5648	
		40	5262	5452	5275	5704	5558	
		45	5572	5296	5446	5706	5637	
		50	5577	5501	5401	5418	5532	
		55	5537	5500	5461	5368	5630	
		60	5476	5667	5465	5701	5722	
		65	5348	5400	5458	5298	5520	
		70	5563	5286	5331	5265	5416	
		75	5385	5319	5494	5363	5644	
		80	5589	5288	5574	5437	5716	
		85	5639	5430	5493	5347	5357	
		90	5685	5567	5709	5283	5316	
		95	5526	5626	5703	5580	5593	

Type 6 Radar Waveform_26

Download	26	Type 6	1.0	333.3	9	0.3333	300.000000	12
		Frequency List (MHz)	0	1	2	3	4	
		0	5397	5423	5386	5515	5582	
		5	5618	5527	5658	5585	5287	
		10	5320	5255	5601	5560	5558	
		15	5289	5505	5329	5405	5344	
		20	5632	5626	5635	5378	5314	
		25	5687	5404	5327	5277	5542	
		30	5615	5689	5569	5480	5709	
		35	5252	5620	5326	5651	5291	
		40	5376	5688	5469	5555	5501	
		45	5276	5529	5337	5353	5416	
		50	5278	5552	5587	5619	5476	
		55	5250	5454	5565	5504	5605	
		60	5357	5503	5390	5388	5379	
		65	5427	5671	5384	5707	5253	
		70	5576	5303	5506	5663	5513	
		75	5685	5699	5385	5462	5715	
		80	5271	5484	5586	5483	5400	
		85	5336	5512	5593	5678	5691	
		90	5363	5719	5352	5343	5300	
		95	5371	5510	5524	5499	5331	

Type 6 Radar Waveform_27

Download	27	Type 6	1.0	333.3	9	0.3333	300.000000	8
		Frequency List (MHz)	0	1	2	3	4	
		0	5652	5284	5322	5676	5424	
		5	5282	5452	5258	5273	5591	
		10	5629	5447	5296	5699	5581	
		15	5646	5416	5608	5277	5694	
		20	5255	5701	5567	5724	5488	
		25	5266	5641	5415	5508	5361	
		30	5528	5572	5332	5721	5678	
		35	5276	5343	5479	5662	5702	
		40	5556	5626	5612	5552	5333	
		45	5634	5250	5390	5618	5292	
		50	5454	5603	5442	5323	5438	
		55	5408	5366	5384	5475	5259	
		60	5522	5448	5697	5689	5325	
		65	5628	5620	5523	5375	5492	
		70	5666	5362	5661	5658	5257	
		75	5696	5486	5368	5551	5392	
		80	5583	5252	5355	5460	5477	
		85	5547	5451	5511	5677	5466	
		90	5656	5709	5317	5426	5494	
		95	5422	5478	5434	5501	5308	

Type 6 Radar Waveform_28

Download	28	Type 6	1.0	333.3	9	0.3333	300.0000000	7
		Frequency List (MHz)	0	1	2	3	4	
		0	5432	5523	5258	5362	5644	
		5	5324	5474	5333	5436	5323	
		10	5560	5711	5337	5419	5602	
		15	5259	5543	5322	5411	5263	
		20	5392	5508	5716	5461	5629	
		25	5590	5521	5612	5395	5458	
		30	5417	5529	5547	5495	5498	
		35	5415	5531	5309	5254	5576	
		40	5541	5639	5564	5377	5646	
		45	5262	5614	5695	5308	5443	
		50	5505	5643	5630	5654	5290	
		55	5265	5267	5626	5556	5678	
		60	5446	5388	5687	5393	5271	
		65	5451	5569	5359	5274	5544	
		70	5478	5291	5686	5637	5617	
		75	5701	5648	5651	5677	5300	
		80	5596	5624	5715	5455	5580	
		85	5672	5423	5720	5345	5598	
		90	5699	5709	5367	5472	5690	
		95	5494	5464	5431	5481	5575	

Type 6 Radar Waveform_29

Download	29	Type 6	1.0	333.3	9	0.3333	300.0000000	5
		Frequency List (MHz)	0	1	2	3	4	
		0	5590	5287	5669	5426	5486	
		5	5366	5399	5408	5599	5530	
		10	5491	5597	5378	5614	5623	
		15	5250	5670	5339	5367	5603	
		20	5271	5558	5449	5330	5434	
		25	5420	5442	5724	5338	5429	
		30	5500	5306	5647	5318	5554	
		35	5622	5580	5407	5490	5380	
		40	5722	5502	5617	5643	5569	
		45	5594	5303	5496	5295	5519	
		50	5331	5705	5379	5563	5589	
		55	5316	5400	5417	5377	5435	
		60	5361	5438	5692	5652	5518	
		65	5298	5484	5685	5363	5616	
		70	5561	5294	5535	5613	5576	
		75	5573	5293	5319	5280	5455	
		80	5609	5405	5404	5480	5690	
		85	5533	5611	5483	5340	5310	
		90	5552	5472	5529	5532	5478	
		95	5627	5376	5448	5536	5559	

Test Site	SIP-TR2	Test Engineer	Alisa Deng
Test Date	2023-03-26		
Test Item	Radar Statistical Performance Check (802.11ax-HE80 – 5530MHz)		

Radar Type 1-4 - Radar Statistical Performance								
Trial	Radar Type 1		Radar Type 2		Radar Type 3		Radar Type 4	
	Frequency (MHz)	1=detect 0=no detect	Frequency (MHz)	1=detect 0=no detect	Frequency (MHz)	1=detect 0=no detect	Frequency (MHz)	1=detect 0=no detect
0	5544	1	5544	1	5530	1	5556	1
1	5550	1	5500	1	5510	1	5536	1
2	5539	1	5512	1	5535	0	5520	1
3	5502	1	5566	0	5539	1	5533	1
4	5536	1	5491	0	5498	1	5506	1
5	5530	1	5544	1	5556	1	5530	1
6	5493	1	5524	1	5525	1	5557	1
7	5534	1	5511	1	5505	1	5538	1
8	5523	1	5550	1	5491	0	5551	1
9	5563	1	5515	1	5515	1	5494	1
10	5550	1	5538	1	5550	1	5498	1
11	5542	1	5569	1	5539	1	5527	1
12	5517	1	5525	1	5526	1	5503	1
13	5543	1	5569	1	5501	1	5529	1
14	5538	1	5504	1	5502	1	5569	0
15	5565	1	5498	1	5493	1	5541	1
16	5538	1	5547	1	5546	1	5547	1
17	5520	1	5562	1	5504	1	5540	1
18	5518	1	5565	1	5501	1	5509	1
19	5562	1	5512	1	5504	1	5547	1
20	5502	1	5563	1	5512	1	5507	1
21	5567	1	5563	1	5503	1	5491	0
22	5554	1	5530	1	5492	1	5501	1
23	5552	1	5565	1	5510	1	5500	1
24	5548	1	5530	1	5498	1	5528	1
25	5491	1	5569	1	5551	1	5494	1
26	5534	1	5491	1	5499	1	5569	1

Radar Type 1-4 - Radar Statistical Performance								
Trial	Radar Type 1		Radar Type 2		Radar Type 3		Radar Type 4	
	Frequency (MHz)	1=detect 0=no detect	Frequency (MHz)	1=detect 0=no detect	Frequency (MHz)	1=detect 0=no detect	Frequency (MHz)	1=detect 0=no detect
27	5517	1	5493	1	5526	1	5566	0
28	5569	1	5494	1	5554	1	5541	1
29	5539	1	5515	1	5569	0	5524	1
Probability:	100.0%		93.3%		90.0%		90.0%	
Aggregate:	93.33% (>80%)							

Radar Type 1 - Radar Waveform							Radar Type 2 - Radar Waveform						
Trial List							Trial List						
	Trial Id	Radar Type	Pulse Width (us)	PRI (us)	Number of Pulses	Waveform Length (us)		Trial Id	Radar Type	Pulse Width (us)	PRI (us)	Number of Pulses	Waveform Length (us)
Download	0	Type 1	1.0	558.0	95	53010.0	Download	0	Type 2	1.4	207.0	23	4761.0
Download	1	Type 1	1.0	758.0	70	53060.0	Download	1	Type 2	1.0	150.0	23	3450.0
Download	2	Type 1	1.0	678.0	78	52884.0	Download	2	Type 2	4.1	208.0	28	5824.0
Download	3	Type 1	1.0	3066.0	18	55188.0	Download	3	Type 2	2.4	178.0	25	4450.0
Download	4	Type 1	1.0	658.0	81	53298.0	Download	4	Type 2	2.5	195.0	25	4875.0
Download	5	Type 1	1.0	578.0	92	53176.0	Download	5	Type 2	3.7	164.0	27	4428.0
Download	6	Type 1	1.0	778.0	68	52904.0	Download	6	Type 2	4.5	189.0	28	5292.0
Download	7	Type 1	1.0	638.0	83	52954.0	Download	7	Type 2	4.1	224.0	28	6272.0
Download	8	Type 1	1.0	918.0	58	53244.0	Download	8	Type 2	1.1	153.0	23	3519.0
Download	9	Type 1	1.0	838.0	63	52794.0	Download	9	Type 2	3.1	228.0	26	5928.0
Download	10	Type 1	1.0	518.0	102	52836.0	Download	10	Type 2	1.2	220.0	23	5060.0
Download	11	Type 1	1.0	738.0	72	53136.0	Download	11	Type 2	2.3	223.0	25	5575.0
Download	12	Type 1	1.0	698.0	76	53048.0	Download	12	Type 2	2.8	159.0	26	4134.0
Download	13	Type 1	1.0	718.0	74	53132.0	Download	13	Type 2	1.7	203.0	24	4872.0
Download	14	Type 1	1.0	818.0	65	53170.0	Download	14	Type 2	4.2	225.0	28	6300.0
Download	15	Type 1	1.0	1932.0	28	54096.0	Download	15	Type 2	3.5	186.0	27	5022.0
Download	16	Type 1	1.0	1452.0	37	53724.0	Download	16	Type 2	2.2	198.0	25	4950.0
Download	17	Type 1	1.0	2383.0	23	54009.0	Download	17	Type 2	2.8	170.0	26	4420.0
Download	18	Type 1	1.0	2388.0	23	54924.0	Download	18	Type 2	4.7	182.0	29	5278.0
Download	19	Type 1	1.0	1815.0	30	54450.0	Download	19	Type 2	4.2	210.0	28	5880.0
Download	20	Type 1	1.0	1431.0	37	52947.0	Download	20	Type 2	2.0	155.0	24	3720.0
Download	21	Type 1	1.0	1864.0	29	54056.0	Download	21	Type 2	1.1	157.0	23	3611.0
Download	22	Type 1	1.0	1016.0	52	52832.0	Download	22	Type 2	1.6	190.0	24	4560.0
Download	23	Type 1	1.0	1591.0	34	54094.0	Download	23	Type 2	3.2	200.0	26	5200.0
Download	24	Type 1	1.0	920.0	58	53360.0	Download	24	Type 2	1.3	172.0	23	3956.0
Download	25	Type 1	1.0	1973.0	27	53271.0	Download	25	Type 2	2.7	192.0	25	4600.0
Download	26	Type 1	1.0	833.0	64	53312.0	Download	26	Type 2	4.9	181.0	29	5249.0
Download	27	Type 1	1.0	1960.0	27	52920.0	Download	27	Type 2	1.9	173.0	24	4152.0
Download	28	Type 1	1.0	2467.0	22	54274.0	Download	28	Type 2	5.0	184.0	29	5336.0
Download	29	Type 1	1.0	2410.0	22	53020.0	Download	29	Type 2	5.0	179.0	29	5191.0



Radar Type 3 - Radar Waveform							Radar Type 4 - Radar Waveform						
Trial List							Trial List						
	Trial Id	Radar Type	Pulse Width (us)	PRI (us)	Number of Pulses	Waveform Length (us)		Trial Id	Radar Type	Pulse Width (us)	PRI (us)	Number of Pulses	Waveform Length (us)
Download	0	Type 3	6.4	339.0	16	5424.0	Download	0	Type 4	11.8	339.0	12	4068.0
Download	1	Type 3	6.0	225.0	16	3600.0	Download	1	Type 4	11.1	225.0	12	2700.0
Download	2	Type 3	9.1	451.0	18	8118.0	Download	2	Type 4	17.9	451.0	15	6765.0
Download	3	Type 3	7.4	209.0	17	3653.0	Download	3	Type 4	14.2	209.0	13	2717.0
Download	4	Type 3	7.5	369.0	17	6273.0	Download	4	Type 4	14.5	369.0	13	4797.0
Download	5	Type 3	8.7	312.0	18	5616.0	Download	5	Type 4	17.1	312.0	15	4680.0
Download	6	Type 3	9.5	280.0	18	5040.0	Download	6	Type 4	18.7	280.0	16	4480.0
Download	7	Type 3	9.1	325.0	18	5850.0	Download	7	Type 4	17.8	325.0	15	4875.0
Download	8	Type 3	6.1	418.0	16	6688.0	Download	8	Type 4	11.3	418.0	12	5016.0
Download	9	Type 3	8.1	284.0	17	4828.0	Download	9	Type 4	15.6	284.0	14	3976.0
Download	10	Type 3	6.2	483.0	16	7728.0	Download	10	Type 4	11.6	483.0	12	5796.0
Download	11	Type 3	7.3	289.0	17	4913.0	Download	11	Type 4	14.0	289.0	13	3757.0
Download	12	Type 3	7.8	375.0	17	6375.0	Download	12	Type 4	15.1	375.0	14	5250.0
Download	13	Type 3	6.7	404.0	16	6464.0	Download	13	Type 4	12.6	404.0	12	4848.0
Download	14	Type 3	9.2	328.0	18	5904.0	Download	14	Type 4	18.2	328.0	16	5248.0
Download	15	Type 3	8.5	338.0	17	5746.0	Download	15	Type 4	16.6	338.0	15	5070.0
Download	16	Type 3	7.2	239.0	16	3824.0	Download	16	Type 4	13.7	239.0	13	3107.0
Download	17	Type 3	7.8	290.0	17	4930.0	Download	17	Type 4	15.0	290.0	14	4060.0
Download	18	Type 3	9.7	384.0	18	6912.0	Download	18	Type 4	19.3	384.0	16	6144.0
Download	19	Type 3	9.2	247.0	18	4446.0	Download	19	Type 4	18.1	247.0	15	3705.0
Download	20	Type 3	7.0	470.0	16	7520.0	Download	20	Type 4	13.3	470.0	13	6110.0
Download	21	Type 3	6.1	232.0	16	3712.0	Download	21	Type 4	11.4	232.0	12	2784.0
Download	22	Type 3	6.6	389.0	16	6224.0	Download	22	Type 4	12.5	389.0	12	4668.0
Download	23	Type 3	8.2	258.0	17	4386.0	Download	23	Type 4	16.0	258.0	14	3612.0
Download	24	Type 3	6.3	324.0	16	5184.0	Download	24	Type 4	11.8	324.0	12	3888.0
Download	25	Type 3	7.7	330.0	17	5610.0	Download	25	Type 4	14.8	330.0	14	4620.0
Download	26	Type 3	9.9	393.0	18	7074.0	Download	26	Type 4	19.8	393.0	16	6288.0
Download	27	Type 3	6.9	425.0	16	6800.0	Download	27	Type 4	13.1	425.0	13	5525.0
Download	28	Type 3	10.0	230.0	18	4140.0	Download	28	Type 4	19.9	230.0	16	3680.0
Download	29	Type 3	10.0	215.0	18	3870.0	Download	29	Type 4	19.9	215.0	16	3440.0

Radar Type 5 - Radar Statistical Performance					
Trail #	Test Freq. (MHz)	1=Detection 0=No Detection	Trail #	Test Freq. (MHz)	1=Detection 0=No Detection
0	5530	0	15	5497	1
1	5530	1	16	5495	1
2	5530	1	17	5496	1
3	5530	1	18	5499	1
4	5530	1	19	5498	1
5	5530	1	20	5565	0
6	5530	1	21	5566	0
7	5530	1	22	5566	1
8	5530	1	23	5563	1
9	5530	1	24	5566	1
10	5494	1	25	5564	1
11	5496	1	26	5560	1
12	5496	1	27	5565	1
13	5494	1	28	5560	1
14	5498	1	29	5560	1
Detection Percentage (%)			90.0%		

Type 5 Radar Waveform_0

Download	0	Type 5	9	1.3333333	12.0000000	5.530000000				
		Burst ID	Burst Offset (us)	Pulse Width (us)	Chirp Width (MHz)	Number of Pulses per Burst	PRI-1 (us)	PRI-2 (us)	PRI-3 (us)	
		0	453860.0	54.9	6	1	1141.0	-	-	
		1	776704.0	50.7	6	1	1579.0	-	-	
		2	1097627.0	88.3	6	3	1001.0	1277.0	1807.0	
		3	90821.0	67.9	6	2	1596.0	1630.0	-	
		4	413639.0	69.4	6	2	1461.0	1042.0	-	
		5	735168.0	84.1	6	3	1654.0	1445.0	1643.0	
		6	1057744.0	92.8	6	3	1153.0	1554.0	1594.0	
		7	51044.0	87.9	6	3	1669.0	1578.0	1032.0	
		8	374278.0	52.0	6	1	1089.0	-	-	

Type 5 Radar Waveform_1

Download	1	Type 5	8	1.5000000	12.0000000	5.530000000				
		Burst ID	Burst Offset (us)	Pulse Width (us)	Chirp Width (MHz)	Number of Pulses per Burst	PRI-1 (us)	PRI-2 (us)	PRI-3 (us)	
		0	784081.0	75.8	5	2	1144.0	1002.0	-	
		1	1148179.0	53.6	5	1	1073.0	-	-	
		2	12779.0	67.0	5	2	1022.0	1238.0	-	
		3	375927.0	72.8	5	2	1206.0	1457.0	-	
		4	739839.0	58.9	5	1	1123.0	-	-	
		5	1100437.0	90.1	5	3	1646.0	1719.0	1733.0	
		6	1465148.0	81.1	5	2	1752.0	1150.0	-	
		7	331431.0	65.3	5	1	1595.0	-	-	

Type 5 Radar Waveform_2

Download	2	Type 5	17	0.7058824	12.0000000	5.530000000				
		Burst ID	Burst Offset (us)	Pulse Width (us)	Chirp Width (MHz)	Number of Pulses per Burst	PRI-1 (us)	PRI-2 (us)	PRI-3 (us)	
		0	328017.0	72.4	17	2	1164.0	1673.0	-	
		1	495252.0	96.1	17	3	1504.0	1177.0	1962.0	
		2	666024.0	89.1	17	3	1291.0	1340.0	1276.0	
		3	134719.0	63.2	17	1	1711.0	-	-	
		4	305441.0	52.2	17	1	1854.0	-	-	
		5	476697.0	58.4	17	1	1104.0	-	-	
		6	645712.0	77.6	17	2	1763.0	1426.0	-	
		7	113645.0	54.5	17	1	1941.0	-	-	
		8	283606.0	71.1	17	2	1884.0	1956.0	-	
		9	453627.0	98.4	17	3	1069.0	1385.0	1767.0	
		10	626088.0	61.7	17	1	1650.0	-	-	
		11	92229.0	99.1	17	3	1139.0	1759.0	1981.0	
		12	262596.0	99.3	17	3	1039.0	1392.0	1507.0	
		13	432841.0	84.4	17	3	1088.0	1174.0	1695.0	
		14	604967.0	52.1	17	1	1746.0	-	-	
		15	71413.0	85.1	17	3	1000.0	1212.0	1430.0	
		16	242510.0	63.4	17	1	1371.0	-	-	

Type 5 Radar Waveform_3

Download	3	Type 5	12	1.0000000	12.0000000	5.530000000				
		Burst ID	Burst Offset (us)	Pulse Width (us)	Chirp Width (MHz)	Number of Pulses per Burst	PRI-1 (us)	PRI-2 (us)	PRI-3 (us)	
		0	585294.0	74.6	10	2	1418.0	1072.0	-	
		1	826296.0	70.3	10	2	1800.0	1806.0	-	
		2	71618.0	72.1	10	2	1617.0	1170.0	-	
		3	313055.0	89.2	10	3	1387.0	1698.0	1031.0	
		4	554115.0	97.6	10	3	1437.0	1764.0	1765.0	
		5	796788.0	66.8	10	2	1664.0	1620.0	-	
		6	41819.0	70.7	10	2	1505.0	1456.0	-	
		7	284003.0	61.5	10	1	1660.0	-	-	
		8	524381.0	93.0	10	3	1694.0	1465.0	1823.0	
		9	766258.0	99.5	10	3	1037.0	1525.0	1700.0	
		10	12051.0	65.2	10	1	1537.0	-	-	
		11	254306.0	61.1	10	1	1159.0	-	-	

Type 5 Radar Waveform_4

Download	4	Type 5	13	0.9230769	12.0000000	5.530000000				
		Burst ID	Burst Offset (us)	Pulse Width (us)	Chirp Width (MHz)	Number of Pulses per Burst	PRI-1 (us)	PRI-2 (us)	PRI-3 (us)	
		0	456735.0	88.4	11	3	1613.0	1214.0	1511.0	
		1	679087.0	92.5	11	3	1513.0	1791.0	1670.0	
		2	904154.0	71.1	11	2	1313.0	1220.0	--	
		3	206451.0	83.4	11	3	1846.0	1413.0	1142.0	
		4	430819.0	61.4	11	1	1062.0	--	--	
		5	653836.0	53.0	11	1	1907.0	--	--	
		6	875408.0	92.0	11	3	1156.0	1361.0	1323.0	
		7	179609.0	64.7	11	1	1306.0	--	--	
		8	403272.0	54.3	11	1	1066.0	--	--	
		9	626586.0	52.6	11	1	1512.0	--	--	
		10	847261.0	92.4	11	3	1328.0	1497.0	1758.0	
		11	152118.0	60.6	11	1	1023.0	--	--	
		12	375375.0	63.4	11	1	1932.0	--	--	

Type 5 Radar Waveform_5

Download	5	Type 5	16	0.7500000	12.0000000	5.530000000				
		Burst ID	Burst Offset (us)	Pulse Width (us)	Chirp Width (MHz)	Number of Pulses per Burst	PRI-1 (us)	PRI-2 (us)	PRI-3 (us)	
		0	484737.0	98.3	15	3	1955.0	1329.0	1014.0	
		1	665968.0	85.7	15	3	1534.0	1080.0	1264.0	
		2	100826.0	81.1	15	2	1776.0	1937.0	--	
		3	281348.0	88.8	15	3	1070.0	1928.0	1976.0	
		4	463887.0	52.7	15	1	1996.0	--	--	
		5	643126.0	91.4	15	3	1560.0	1661.0	1296.0	
		6	78735.0	51.4	15	1	1771.0	--	--	
		7	259670.0	82.0	15	2	1885.0	1422.0	--	
		8	441856.0	59.4	15	1	1462.0	--	--	
		9	620391.0	84.3	15	3	1969.0	1472.0	1634.0	
		10	56338.0	69.7	15	2	1278.0	1084.0	--	
		11	238017.0	59.0	15	1	1252.0	--	--	
		12	418628.0	76.2	15	2	1266.0	1741.0	--	
		13	599262.0	74.9	15	2	1836.0	1838.0	--	
		14	33978.0	79.3	15	2	1341.0	1565.0	--	
		15	215164.0	68.3	15	2	1881.0	1051.0	--	

Type 5 Radar Waveform_6

Download	6	Type 5	19	0.6315789	12.0000000	5.530000000				
		Burst ID	Burst Offset (us)	Pulse Width (us)	Chirp Width (MHz)	Number of Pulses per Burst	PRI-1 (us)	PRI-2 (us)	PRI-3 (us)	
		0	334480.0	51.6	18	1	1131.0	--	--	
		1	487314.0	59.2	18	1	1221.0	--	--	
		2	9633.0	58.9	18	1	1544.0	--	--	
		3	162674.0	62.4	18	1	1397.0	--	--	
		4	314377.0	93.4	18	3	1055.0	1092.0	1518.0	
		5	467742.0	82.8	18	2	1021.0	1196.0	--	
		6	620877.0	55.9	18	1	1715.0	--	--	
		7	143286.0	90.6	18	3	1047.0	1648.0	1160.0	
		8	296732.0	65.6	18	1	1300.0	--	--	
		9	447475.0	87.9	18	3	1315.0	1180.0	1777.0	
		10	600726.0	81.4	18	2	1924.0	1187.0	--	
		11	125022.0	60.1	18	1	1391.0	--	--	
		12	277086.0	70.3	18	2	1655.0	1498.0	--	
		13	430732.0	59.0	18	1	1349.0	--	--	
		14	581937.0	71.9	18	2	1417.0	1709.0	--	
		15	105964.0	78.0	18	2	1085.0	1682.0	--	
		16	259114.0	61.4	18	1	1201.0	--	--	
		17	410993.0	75.8	18	2	1171.0	1572.0	--	
		18	561824.0	99.3	18	3	1542.0	1762.0	1316.0	

Type 5 Radar Waveform_7

Download	7	Type 5	17	0.7058824	12.0000000	5.530000000				
		Burst ID	Burst Offset (us)	Pulse Width (us)	Chirp Width (MHz)	Number of Pulses per Burst	PRI-1 (us)	PRI-2 (us)	PRI-3 (us)	
		0	97405.0	81.1	17	2	1309.0	1998.0	--	
		1	267549.0	89.6	17	3	1487.0	1040.0	1443.0	
		2	438573.0	72.7	17	2	1434.0	1273.0	--	
		3	607664.0	90.2	17	3	1503.0	1007.0	1873.0	
		4	76601.0	58.1	17	1	1609.0	--	--	
		5	247430.0	63.7	17	1	1552.0	--	--	
		6	417602.0	79.2	17	2	1183.0	1463.0	--	
		7	587152.0	78.9	17	2	1865.0	1986.0	--	
		8	55551.0	58.2	17	1	1742.0	--	--	
		9	226470.0	51.4	17	1	1298.0	--	--	
		10	396291.0	74.4	17	2	1964.0	1219.0	--	
		11	564572.0	85.3	17	3	1961.0	1983.0	1900.0	
		12	34470.0	78.2	17	2	1548.0	1117.0	--	
		13	205371.0	62.7	17	1	1468.0	--	--	
		14	374292.0	96.4	17	3	1747.0	1618.0	1702.0	
		15	546735.0	52.7	17	1	1883.0	--	--	
		16	13440.0	93.5	17	3	1474.0	1225.0	1099.0	

Type 5 Radar Waveform_8

Download	8	Type 5	8	1.5000000	12.0000000	5.530000000				
		Burst ID	Burst Offset (us)	Pulse Width (us)	Chirp Width (MHz)	Number of Pulses per Burst	PRI-1 (us)	PRI-2 (us)	PRI-3 (us)	
		0	391187.0	83.4	5	3	1691.0	1467.0	1904.0	
		1	754605.0	98.2	5	3	1241.0	1109.0	1030.0	
		2	1117313.0	70.0	5	2	1841.0	1899.0	--	
		3	1482130.0	65.5	5	1	1793.0	--	--	
		4	346855.0	79.8	5	2	1690.0	1953.0	--	
		5	709364.0	90.6	5	3	1942.0	1078.0	1477.0	
		6	1073211.0	73.2	5	2	1728.0	1178.0	--	
		7	1437551.0	64.9	5	1	1605.0	--	--	

Type 5 Radar Waveform_9

Download	9	Type 5	14	0.8571429	12.0000000	5.530000000				
		Burst ID	Burst Offset (us)	Pulse Width (us)	Chirp Width (MHz)	Number of Pulses per Burst	PRI-1 (us)	PRI-2 (us)	PRI-3 (us)	
		0	172752.0	60.0	13	1	1621.0	--	--	
		1	379065.0	91.3	13	3	1394.0	1058.0	1820.0	
		2	587642.0	61.6	13	1	1755.0	--	--	
		3	795203.0	50.3	13	1	1644.0	--	--	
		4	147205.0	62.3	13	1	1553.0	--	--	
		5	353108.0	91.8	13	3	1680.0	1896.0	1847.0	
		6	560477.0	97.6	13	3	1750.0	1146.0	1310.0	
		7	769439.0	50.3	13	1	1874.0	--	--	
		8	121348.0	75.6	13	2	1870.0	1774.0	--	
		9	328394.0	98.2	13	3	1326.0	1143.0	1057.0	
		10	535953.0	78.8	13	2	1667.0	1013.0	--	
		11	742227.0	78.9	13	2	1805.0	1979.0	--	
		12	95830.0	69.0	13	2	2000.0	1825.0	--	
		13	303743.0	50.8	13	1	1128.0	--	--	

Type 5 Radar Waveform_10

Download	10	Type 5	8	1.5000000	12.0000000	5.494000000				
		Burst ID	Burst Offset (us)	Pulse Width (us)	Chirp Width (MHz)	Number of Pulses per Burst	PRI-1 (us)	PRI-2 (us)	PRI-3 (us)	
		0	893390.0	98.7	6	3	1496.0	1494.0	1460.0	
		1	1258221.0	64.1	6	1	1934.0	--	--	
		2	123552.0	53.8	6	1	1097.0	--	--	
		3	485961.0	97.7	6	3	1676.0	1348.0	1526.0	
		4	849061.0	89.2	6	3	1086.0	1255.0	1493.0	
		5	1211776.0	91.3	6	3	1344.0	1095.0	1583.0	
		6	78761.0	52.5	6	1	1331.0	--	--	
		7	442105.0	53.1	6	1	1772.0	--	--	

Type 5 Radar Waveform_11

Download	11	Type 5	12	1.0000000	12.0000000	5.496000000				
		Burst ID	Burst Offset (us)	Pulse Width (us)	Chirp Width (MHz)	Number of Pulses per Burst	PRI-1 (us)	PRI-2 (us)	PRI-3 (us)	
		0	534851.0	97.5	10	3	1559.0	1737.0	1849.0	
		1	777224.0	74.0	10	2	1812.0	1936.0	-	
		2	22851.0	56.2	10	1	1251.0	-	-	
		3	264435.0	78.5	10	2	1029.0	1898.0	-	
		4	505372.0	94.7	10	3	1730.0	1400.0	1539.0	
		5	749069.0	63.2	10	1	1606.0	-	-	
		6	991525.0	55.7	10	1	1290.0	-	-	
		7	234176.0	83.8	10	3	1466.0	1779.0	1688.0	
		8	477080.0	51.3	10	1	1649.0	-	-	
		9	717033.0	99.1	10	3	1835.0	1263.0	1576.0	
		10	957831.0	99.6	10	3	1920.0	1475.0	1901.0	
		11	204871.0	75.3	10	2	1053.0	1824.0	-	

Type 5 Radar Waveform_12

Download	12	Type 5	13	0.9230769	12.0000000	5.496000000				
		Burst ID	Burst Offset (us)	Pulse Width (us)	Chirp Width (MHz)	Number of Pulses per Burst	PRI-1 (us)	PRI-2 (us)	PRI-3 (us)	
		0	411551.0	98.1	12	3	1012.0	1729.0	1683.0	
		1	635600.0	72.4	12	2	1096.0	1523.0	-	
		2	858758.0	67.6	12	2	1347.0	1359.0	-	
		3	161597.0	78.6	12	2	1016.0	1744.0	-	
		4	384132.0	96.0	12	3	1293.0	1866.0	1205.0	
		5	608799.0	59.6	12	1	1563.0	-	-	
		6	830839.0	76.8	12	2	1782.0	1393.0	-	
		7	134006.0	84.9	12	3	1161.0	1163.0	1101.0	
		8	357990.0	52.5	12	1	1006.0	-	-	
		9	581158.0	64.6	12	1	1740.0	-	-	
		10	803891.0	67.5	12	2	1083.0	1481.0	-	
		11	106587.0	73.9	12	2	1383.0	1568.0	-	
		12	329524.0	74.4	12	2	1930.0	1641.0	-	

Type 5 Radar Waveform_13

Download	13	Type 5	10	1.2000000	12.0000000	5.494000000				
		Burst ID	Burst Offset (us)	Pulse Width (us)	Chirp Width (MHz)	Number of Pulses per Burst	PRI-1 (us)	PRI-2 (us)	PRI-3 (us)	
		0	719440.0	82.5	7	2	1063.0	1671.0	-	
		1	1008268.0	99.5	7	3	1766.0	1370.0	1432.0	
		2	103018.0	55.8	7	1	1631.0	-	-	
		3	393735.0	61.7	7	1	1403.0	-	-	
		4	683350.0	82.1	7	2	1869.0	1429.0	-	
		5	975104.0	51.4	7	1	1435.0	-	-	
		6	67174.0	81.9	7	2	1035.0	1378.0	-	
		7	357901.0	62.3	7	1	1492.0	-	-	
		8	648830.0	56.8	7	1	1025.0	-	-	
		9	936319.0	93.9	7	3	1931.0	1358.0	1946.0	

Type 5 Radar Waveform_14

Download	14	Type 5	18	0.8888887	12.0000000	5.496000000				
		Burst ID	Burst Offset (us)	Pulse Width (us)	Chirp Width (MHz)	Number of Pulses per Burst	PRI-1 (us)	PRI-2 (us)	PRI-3 (us)	
		0	17380.0	87.6	17	3	1597.0	1044.0	1088.0	
		1	178124.0	94.1	17	3	1367.0	1261.0	1248.0	
		2	338139.0	83.8	17	3	1829.0	1877.0	1603.0	
		3	498935.0	97.2	17	3	1785.0	1875.0	1124.0	
		4	660227.0	84.4	17	3	1061.0	1909.0	1046.0	
		5	158223.0	94.6	17	3	1438.0	1020.0	1837.0	
		6	318715.0	91.9	17	3	1997.0	1168.0	1451.0	
		7	479353.0	96.8	17	3	1499.0	1984.0	1036.0	
		8	641203.0	79.8	17	2	1861.0	1356.0	-	
		9	138758.0	79.3	17	2	1208.0	1543.0	-	
		10	299389.0	93.8	17	3	1152.0	1325.0	1136.0	
		11	461591.0	52.7	17	1	1610.0	-	-	
		12	621205.0	76.3	17	2	1551.0	1856.0	-	
		13	118460.0	96.6	17	3	1905.0	1681.0	1753.0	
		14	279452.0	75.3	17	2	1947.0	1973.0	-	
		15	442078.0	51.7	17	1	1076.0	-	-	
		16	601005.0	79.5	17	2	1882.0	1950.0	-	
		17	99302.0	64.5	17	1	1334.0	-	-	

Type 5 Radar Waveform_15

Download	15	Type 5	16	0.7500000	12.0000000	5.497000000				
		Burst ID	Burst Offset (us)	Pulse Width (us)	Chirp Width (MHz)	Number of Pulses per Burst	PRI-1 (us)	PRI-2 (us)	PRI-3 (us)	
		0	292787.0	67.7	14	2	1629.0	1049.0	-	
		1	474579.0	50.6	14	1	1822.0	-	-	
		2	655284.0	82.8	14	2	1540.0	1140.0	-	
		3	89345.0	56.4	14	1	1570.0	-	-	
		4	270278.0	82.4	14	2	1247.0	1939.0	-	
		5	452254.0	54.1	14	1	1780.0	-	-	
		6	634286.0	62.1	14	1	1112.0	-	-	
		7	66964.0	63.7	14	1	1813.0	-	-	
		8	247505.0	100.0	14	3	1628.0	1619.0	1332.0	
		9	429016.0	72.1	14	2	1357.0	1963.0	-	
		10	609979.0	69.2	14	2	1490.0	1990.0	-	
		11	44466.0	97.6	14	3	1259.0	1305.0	1704.0	
		12	225749.0	67.7	14	2	1778.0	1102.0	-	
		13	407445.0	62.9	14	1	1971.0	-	-	
		14	587304.0	91.3	14	3	1598.0	1158.0	1198.0	
		15	22217.0	78.6	14	2	1335.0	1970.0	-	

Type 5 Radar Waveform_16

Download	16	Type 5	11	1.0909091	12.0000000	5.495000000				
		Burst ID	Burst Offset (us)	Pulse Width (us)	Chirp Width (MHz)	Number of Pulses per Burst	PRI-1 (us)	PRI-2 (us)	PRI-3 (us)	
		0	296228.0	80.1	9	2	1292.0	1684.0	-	
		1	559403.0	84.5	9	3	1008.0	1322.0	1972.0	
		2	824897.0	82.1	9	1	1718.0	-	-	
		3	1089627.0	82.5	9	1	1151.0	-	-	
		4	263216.0	92.4	9	3	1770.0	1626.0	1685.0	
		5	526970.0	90.3	9	3	1652.0	1582.0	1010.0	
		6	792290.0	80.6	9	1	1811.0	-	-	
		7	1054768.0	67.8	9	2	1769.0	1756.0	-	
		8	230776.0	87.8	9	3	1723.0	1421.0	1944.0	
		9	493855.0	94.7	9	3	1999.0	1925.0	1751.0	
		10	758418.0	80.7	9	2	1809.0	1918.0	-	

Type 5 Radar Waveform_17

Download	17	Type 5	13	0.9230769	12.0000000	5.496000000				
		Burst ID	Burst Offset (us)	Pulse Width (us)	Chirp Width (MHz)	Number of Pulses per Burst	PRI-1 (us)	PRI-2 (us)	PRI-3 (us)	
		0	864645.0	79.8	12	2	1384.0	1985.0	-	
		1	168103.0	73.2	12	2	1736.0	1045.0	-	
		2	392005.0	59.3	12	1	1132.0	-	-	
		3	613799.0	86.4	12	3	1071.0	1061.0	1686.0	
		4	837766.0	80.4	12	2	1268.0	1446.0	-	
		5	140621.0	72.0	12	2	1535.0	1173.0	-	
		6	363567.0	67.3	12	2	1402.0	1995.0	-	
		7	586087.0	94.7	12	3	1254.0	1374.0	1601.0	
		8	811296.0	56.2	12	1	1549.0	-	-	
		9	113308.0	61.0	12	1	1226.0	-	-	
		10	336129.0	81.1	12	2	1795.0	1501.0	-	
		11	560227.0	61.7	12	1	1615.0	-	-	
		12	781865.0	79.7	12	2	1859.0	1926.0	-	

Type 5 Radar Waveform_18

Download	18	Type 5	19	0.6315789	12.0000000	5.499000000				
		Burst ID	Burst Offset (us)	Pulse Width (us)	Chirp Width (MHz)	Number of Pulses per Burst	PRI-1 (us)	PRI-2 (us)	PRI-3 (us)	
		0	56295.0	85.0	19	3	1958.0	1126.0	1929.0	
		1	211026.0	70.6	19	2	1244.0	1479.0	--	
		2	362569.0	94.7	19	3	1033.0	1407.0	1968.0	
		3	515921.0	89.8	19	2	1637.0	1256.0	--	
		4	39676.0	77.5	19	2	1745.0	1705.0	--	
		5	192128.0	82.2	19	2	1245.0	1842.0	--	
		6	345582.0	61.6	19	1	1217.0	--	--	
		7	496476.0	80.8	19	2	1910.0	1821.0	--	
		8	20982.0	61.5	19	1	1304.0	--	--	
		9	172847.0	97.7	19	3	1115.0	1851.0	1952.0	
		10	326680.0	66.5	19	1	1353.0	--	--	
		11	476585.0	90.8	19	3	1923.0	1799.0	1500.0	
		12	2140.0	89.6	19	3	1423.0	1853.0	1892.0	
		13	154595.0	66.9	19	2	1192.0	1818.0	--	
		14	306969.0	72.1	19	2	1933.0	1227.0	--	
		15	459788.0	77.4	19	2	1458.0	1145.0	--	
		16	811182.0	90.0	19	3	1246.0	1121.0	1420.0	
		17	136163.0	64.9	19	1	1410.0	--	--	
		18	288546.0	68.7	19	2	1043.0	1354.0	--	

Type 5 Radar Waveform_19

Download	19	Type 5	18	0.6666667	12.0000000	5.496000000				
		Burst ID	Burst Offset (us)	Pulse Width (us)	Chirp Width (MHz)	Number of Pulses per Burst	PRI-1 (us)	PRI-2 (us)	PRI-3 (us)	
		0	464186.0	87.8	17	3	1506.0	1433.0	1679.0	
		1	625703.0	73.4	17	2	1710.0	1902.0	--	
		2	123548.0	82.4	17	2	1249.0	1890.0	--	
		3	283957.0	90.5	17	3	1529.0	1622.0	1194.0	
		4	444447.0	90.7	17	3	1439.0	1712.0	1409.0	
		5	605797.0	85.7	17	3	1107.0	1233.0	1379.0	
		6	103597.0	88.9	17	3	1398.0	1342.0	1223.0	
		7	264796.0	75.6	17	2	1260.0	1519.0	--	
		8	426592.0	50.3	17	1	1558.0	--	--	
		9	587335.0	68.3	17	2	1125.0	1075.0	--	
		10	83694.0	85.1	17	3	1611.0	1338.0	1843.0	
		11	244736.0	67.5	17	2	1399.0	1993.0	--	
		12	404657.0	99.0	17	3	1754.0	1897.0	1286.0	
		13	566193.0	72.8	17	2	1721.0	1991.0	--	
		14	64082.0	82.5	17	2	1852.0	1279.0	--	
		15	224955.0	77.6	17	2	1974.0	1318.0	--	
		16	386011.0	71.8	17	2	1419.0	1587.0	--	
		17	545559.0	95.7	17	3	1330.0	1787.0	1600.0	

Type 5 Radar Waveform_20

Download	20	Type 5	11	1.0909091	12.0000000	5.585000000				
		Burst ID	Burst Offset (us)	Pulse Width (us)	Chirp Width (MHz)	Number of Pulses per Burst	PRI-1 (us)	PRI-2 (us)	PRI-3 (us)	
		0	72502.0	90.8	9	3	1232.0	1288.0	1416.0	
		1	335812.0	90.4	9	3	1826.0	1406.0	1724.0	
		2	601021.0	55.5	9	1	1639.0	--	--	
		3	864319.0	83.1	9	2	1224.0	1528.0	--	
		4	40018.0	99.9	9	3	1110.0	1351.0	1810.0	
		5	304122.0	68.3	9	2	1111.0	1155.0	--	
		6	567762.0	75.6	9	2	1362.0	1651.0	--	
		7	830063.0	92.8	9	3	1903.0	1761.0	1375.0	
		8	7556.0	95.7	9	3	1082.0	1444.0	1653.0	
		9	270967.0	90.9	9	3	1726.0	1127.0	1948.0	
		10	535919.0	55.0	9	1	1677.0	--	--	

Type 5 Radar Waveform_21

Download	21	Type 5	8	1.5000000	12.0000000	5.566000000				
		Burst ID	Burst Offset (us)	Pulse Width (us)	Chirp Width (MHz)	Number of Pulses per Burst	PRI-1 (us)	PRI-2 (us)	PRI-3 (us)	
		0	1098664.0	95.3	5	3	1831.0	1284.0	1181.0	
		1	1462815.0	67.2	5	2	1585.0	1283.0	-	
		2	329007.0	66.2	5	1	1855.0	-	-	
		3	691560.0	96.1	5	3	1130.0	1428.0	1015.0	
		4	1055632.0	62.4	5	1	1954.0	-	-	
		5	1417161.0	74.0	5	2	1927.0	1922.0	-	
		6	284321.0	56.2	5	1	1484.0	-	-	
		7	647651.0	52.6	5	1	1732.0	-	-	

Type 5 Radar Waveform_22

Download	22	Type 5	10	1.2000000	12.0000000	5.566000000				
		Burst ID	Burst Offset (us)	Pulse Width (us)	Chirp Width (MHz)	Number of Pulses per Burst	PRI-1 (us)	PRI-2 (us)	PRI-3 (us)	
		0	807542.0	80.1	7	2	1796.0	1488.0	-	
		1	1099857.0	54.0	7	1	1024.0	-	-	
		2	191180.0	84.2	7	3	1824.0	1210.0	1250.0	
		3	481210.0	88.7	7	3	1828.0	1297.0	1003.0	
		4	772997.0	56.6	7	1	1414.0	-	-	
		5	1063285.0	61.2	7	1	1872.0	-	-	
		6	155750.0	62.4	7	1	1802.0	-	-	
		7	445940.0	76.4	7	2	1781.0	1122.0	-	
		8	736166.0	80.2	7	2	1508.0	1571.0	-	
		9	1026565.0	67.5	7	2	1567.0	1386.0	-	

Type 5 Radar Waveform_23

Download	23	Type 5	15	0.8000000	12.0000000	5.563000000				
		Burst ID	Burst Offset (us)	Pulse Width (us)	Chirp Width (MHz)	Number of Pulses per Burst	PRI-1 (us)	PRI-2 (us)	PRI-3 (us)	
		0	79851.0	68.0	13	2	1312.0	1077.0	-	
		1	273606.0	57.1	13	1	1486.0	-	-	
		2	464995.0	89.4	13	3	1716.0	1659.0	2000.0	
		3	661145.0	50.3	13	1	1234.0	-	-	
		4	56026.0	81.8	13	2	1004.0	1337.0	-	
		5	248767.0	99.2	13	3	1320.0	1346.0	1967.0	
		6	442451.0	74.6	13	2	1678.0	1546.0	-	
		7	637157.0	63.1	13	1	1390.0	-	-	
		8	32232.0	54.7	13	1	1473.0	-	-	
		9	225638.0	73.6	13	2	1118.0	1282.0	-	
		10	419753.0	64.1	13	1	1120.0	-	-	
		11	613165.0	64.9	13	1	1566.0	-	-	
		12	8344.0	97.9	13	3	1590.0	1734.0	1172.0	
		13	201424.0	90.0	13	3	1382.0	1176.0	1365.0	
		14	394289.0	98.0	13	3	1311.0	1982.0	1041.0	

Type 5 Radar Waveform_24

Download	24	Type 5	9	1.3333333	12.0000000	5.566000000				
		Burst ID	Burst Offset (us)	Pulse Width (us)	Chirp Width (MHz)	Number of Pulses per Burst	PRI-1 (us)	PRI-2 (us)	PRI-3 (us)	
		0	982003.0	70.5	6	2	1442.0	1415.0	-	
		1	1305813.0	55.1	6	1	1707.0	-	-	
		2	297263.0	51.1	6	1	1189.0	-	-	
		3	619584.0	68.8	6	2	1561.0	1274.0	-	
		4	942649.0	71.4	6	2	1275.0	1027.0	-	
		5	1262986.0	86.6	6	3	1401.0	1599.0	1911.0	
		6	256758.0	98.8	6	3	1632.0	1899.0	1521.0	
		7	580055.0	76.2	6	2	1203.0	1129.0	-	
		8	902203.0	74.9	6	2	1935.0	1373.0	-	

Type 5 Radar Waveform_25

Download	25	Type 5	13	0.9230789	12.0000000	5.584000000				
		Burst ID	Burst Offset (us)	Pulse Width (us)	Chirp Width (MHz)	Number of Pulses per Burst	PRI-1 (us)	PRI-2 (us)	PRI-3 (us)	
		0	845902.0	91.7	11	3	1186.0	1989.0	1308.0	
		1	150257.0	91.6	11	3	1079.0	1087.0	1336.0	
		2	373906.0	56.6	11	1	1966.0	--	--	
		3	597468.0	51.6	11	1	1714.0	--	--	
		4	819111.0	99.0	11	3	1360.0	1280.0	1113.0	
		5	122885.0	71.8	11	2	1464.0	1287.0	--	
		6	345413.0	87.4	11	3	1236.0	1689.0	1635.0	
		7	568225.0	91.9	11	3	1106.0	1471.0	1914.0	
		8	791511.0	95.5	11	3	1175.0	1569.0	1166.0	
		9	95366.0	75.3	11	2	1789.0	1200.0	--	
		10	318573.0	77.7	11	2	1555.0	1270.0	--	
		11	540933.0	83.8	11	3	1301.0	1696.0	1239.0	
		12	766439.0	65.7	11	1	1038.0	--	--	

Type 5 Radar Waveform_26

Download	26	Type 5	20	0.6000000	12.0000000	5.580000000				
		Burst ID	Burst Offset (us)	Pulse Width (us)	Chirp Width (MHz)	Number of Pulses per Burst	PRI-1 (us)	PRI-2 (us)	PRI-3 (us)	
		0	43894.0	94.9	20	3	1672.0	1817.0	1536.0	
		1	188541.0	85.5	20	3	1191.0	1720.0	1019.0	
		2	333467.0	67.1	20	2	1564.0	1722.0	--	
		3	478191.0	71.5	20	2	1608.0	1675.0	--	
		4	26128.0	99.3	20	3	1345.0	1975.0	1531.0	
		5	171077.0	69.3	20	2	1065.0	1666.0	--	
		6	315626.0	82.7	20	2	1364.0	1949.0	--	
		7	459106.0	88.6	20	3	1483.0	1616.0	1815.0	
		8	8392.0	65.2	20	1	1735.0	--	--	
		9	153544.0	56.2	20	1	1524.0	--	--	
		10	297360.0	94.3	20	3	1253.0	1094.0	1848.0	
		11	441506.0	90.7	20	3	1830.0	1527.0	1317.0	
		12	586061.0	86.1	20	3	1450.0	1640.0	1412.0	
		13	135760.0	56.1	20	1	1103.0	--	--	
		14	280976.0	61.3	20	1	1179.0	--	--	
		15	426048.0	57.6	20	1	1405.0	--	--	
		16	570696.0	58.7	20	1	1960.0	--	--	
		17	117532.0	81.0	20	2	1788.0	1026.0	--	
		18	262344.0	69.2	20	2	1541.0	1327.0	--	
		19	407194.0	80.9	20	2	1449.0	1381.0	--	

Type 5 Radar Waveform_27

Download	27	Type 5	11	1.0909091	12.0000000	5.585000000				
		Burst ID	Burst Offset (us)	Pulse Width (us)	Chirp Width (MHz)	Number of Pulses per Burst	PRI-1 (us)	PRI-2 (us)	PRI-3 (us)	
		0	1006899.0	64.4	8	1	1668.0	--	--	
		1	181872.0	56.6	8	1	1431.0	--	--	
		2	444891.0	90.2	8	3	1452.0	1489.0	1454.0	
		3	708169.0	92.6	8	3	1602.0	1562.0	1593.0	
		4	972852.0	73.0	8	2	1916.0	1436.0	--	
		5	149305.0	64.1	8	1	1574.0	--	--	
		6	412994.0	82.9	8	2	1028.0	1886.0	--	
		7	675611.0	86.2	8	3	1840.0	1857.0	1237.0	
		8	940697.0	72.2	8	2	1557.0	1408.0	--	
		9	116677.0	69.5	8	2	1093.0	1272.0	--	
		10	380621.0	72.6	8	2	1005.0	1538.0	--	

Type 5 Radar Waveform_28

Download	28	Type 5	20	0.6000000	12.0000000	5.560000000				
		Burst ID	Burst Offset (us)	Pulse Width (us)	Chirp Width (MHz)	Number of Pulses per Burst	PRI-1 (us)	PRI-2 (us)	PRI-3 (us)	
		0	354198.0	62.2	20	1	1945.0	-	-	
		1	499367.0	64.2	20	1	1798.0	-	-	
		2	46247.0	54.8	20	1	1808.0	-	-	
		3	191282.0	60.2	20	1	1951.0	-	-	
		4	336363.0	65.6	20	1	1888.0	-	-	
		5	481953.0	51.6	20	1	1231.0	-	-	
		6	28225.0	100.0	20	3	1803.0	1350.0	1860.0	
		7	172728.0	87.3	20	3	1522.0	1743.0	1059.0	
		8	318170.0	79.5	20	2	1199.0	1299.0	-	
		9	460741.0	93.6	20	3	1919.0	1994.0	1607.0	
		10	10452.0	86.4	20	3	1731.0	1591.0	1581.0	
		11	155208.0	76.5	20	2	1959.0	1303.0	-	
		12	299297.0	85.4	20	3	1844.0	1575.0	1114.0	
		13	445995.0	62.3	20	1	1476.0	-	-	
		14	591617.0	60.9	20	1	1009.0	-	-	
		15	137871.0	62.9	20	1	1133.0	-	-	
		16	283076.0	65.7	20	1	1216.0	-	-	
		17	427149.0	76.0	20	2	1184.0	1642.0	-	
		18	571132.0	84.2	20	3	1533.0	1091.0	1090.0	
		19	119124.0	86.8	20	3	1889.0	1876.0	1645.0	

Type 5 Radar Waveform_29

Download	29	Type 5	20	0.6000000	12.0000000	5.560000000				
		Burst ID	Burst Offset (us)	Pulse Width (us)	Chirp Width (MHz)	Number of Pulses per Burst	PRI-1 (us)	PRI-2 (us)	PRI-3 (us)	
		0	264053.0	94.3	20	3	1258.0	1453.0	1067.0	
		1	410302.0	58.5	20	1	1376.0	-	-	
		2	555190.0	52.8	20	1	1697.0	-	-	
		3	102074.0	51.2	20	1	1228.0	-	-	
		4	246110.0	66.3	20	3	1218.0	1242.0	1636.0	
		5	390811.0	95.3	20	3	1530.0	1064.0	1235.0	
		6	536090.0	74.6	20	2	1074.0	1988.0	-	
		7	83838.0	98.5	20	3	1448.0	1197.0	1056.0	
		8	228110.0	85.2	20	3	1857.0	1801.0	1154.0	
		9	372406.0	86.4	20	3	1485.0	1509.0	1786.0	
		10	516460.0	96.5	20	3	1887.0	1586.0	1658.0	
		11	66276.0	66.3	20	1	1427.0	-	-	
		12	210304.0	95.8	20	3	1827.0	1556.0	1285.0	
		13	354458.0	83.6	20	3	1938.0	1913.0	1207.0	
		14	500687.0	82.0	20	2	1368.0	1380.0	-	
		15	48245.0	76.5	20	2	1794.0	1480.0	-	
		16	192839.0	81.3	20	2	1832.0	1845.0	-	
		17	336750.0	95.9	20	3	1366.0	1665.0	1912.0	
		18	481400.0	95.8	20	3	1491.0	1701.0	1343.0	
		19	30514.0	55.9	20	1	1389.0	-	-	

Radar Type 6 - Radar Statistical Performance			
Trail #	1=Detection 0=No Detection	Trail #	1=Detection 0=No Detection
0	1	15	1
1	1	16	1
2	1	17	1
3	1	18	1
4	1	19	1
5	1	20	1
6	1	21	1
7	1	22	1
8	1	23	1
9	1	24	1
10	1	25	1
11	1	26	1
12	1	27	1
13	1	28	1
14	1	29	1
Detection Percentage (%)		100.0%	

Type 6 Radar Waveform_0

Download	0	Type 6	1.0	333.3	9	0.3333	300.0000000	16
		Frequency List (MHz)	0	1	2	3	4	
		0	5596	5623	5257	5598	5369	
		5	5696	5400	5284	5470	5506	
		10	5576	5441	5583	5452	5274	
		15	5439	5326	5328	5650	5500	
		20	5495	5554	5683	5570	5462	
		25	5604	5270	5483	5435	5666	
		30	5447	5675	5310	5443	5509	
		35	5518	5494	5251	5278	5393	
		40	5693	5613	5394	5612	5667	
		45	5312	5635	5527	5586	5531	
		50	5292	5287	5412	5386	5587	
		55	5298	5642	5671	5626	5406	
		60	5250	5588	5523	5356	5490	
		65	5498	5630	5656	5649	5472	
		70	5352	5476	5569	5557	5383	
		75	5638	5590	5537	5396	5339	
		80	5504	5401	5382	5254	5300	
		85	5458	5544	5317	5398	5372	
		90	5427	5322	5603	5461	5429	
		95	5431	5536	5665	5280	5640	

Type 6 Radar Waveform_1

Download	1	Type 6	1.0	333.3	9	0.3333	300.0000000	21
		Frequency List (MHz)	0	1	2	3	4	
		0	5376	5484	5668	5284	5686	
		5	5263	5325	5359	5633	5713	
		10	5507	5705	5624	5647	5295	
		15	5527	5453	5431	5598	5692	
		20	5503	5720	5721	5562	5435	
		25	5492	5597	5539	5603	5489	
		30	5632	5525	5329	5330	5609	
		35	5290	5404	5667	5707	5301	
		40	5395	5491	5610	5701	5495	
		45	5275	5628	5365	5522	5306	
		50	5287	5582	5478	5488	5356	
		55	5574	5444	5461	5545	5280	
		60	5571	5292	5420	5446	5302	
		65	5313	5447	5666	5521	5291	
		70	5576	5418	5550	5516	5352	
		75	5661	5258	5585	5314	5506	
		80	5595	5464	5566	5699	5285	
		85	5553	5509	5271	5646	5546	
		90	5537	5602	5540	5309	5381	
		95	5684	5408	5534	5259	5663	

Type 6 Radar Waveform_2

Download	2	Type 6	1.0	333.3	9	0.3333	300.0000000	15
		Frequency List (MHz)	0	1	2	3	4	
		0	5631	5723	5604	5445	5431	
		5	5305	5347	5434	5321	5542	
		10	5438	5591	5665	5367	5316	
		15	5518	5580	5534	5643	5409	
		20	5511	5411	5662	5651	5408	
		25	5283	5449	5414	5637	5531	
		30	5451	5589	5265	5369	5527	
		35	5372	5700	5561	5654	5678	
		40	5384	5333	5256	5704	5630	
		45	5475	5358	5418	5312	5657	
		50	5463	5633	5567	5311	5287	
		55	5398	5658	5516	5261	5712	
		60	5252	5272	5514	5396	5605	
		65	5698	5336	5553	5593	5277	
		70	5579	5267	5526	5306	5304	
		75	5566	5616	5376	5357	5624	
		80	5563	5285	5413	5323	5270	
		85	5377	5322	5419	5269	5702	
		90	5608	5477	5666	5443	5538	
		95	5436	5668	5257	5387	5457	

Type 6 Radar Waveform_3

Download	3	Type 6	1.0	333.3	9	0.3333	300.0000000	15
		Frequency List (MHz)	0	1	2	3	4	
		0	5411	5487	5540	5606	5273	
		5	5444	5272	5509	5484	5274	
		10	5380	5706	5562	5337	5707	
		15	5688	5601	5422	5480	5603	
		20	5643	5381	5646	5398	5617	
		25	5671	5670	5437	5546	5383	
		30	5618	5347	5511	5316	5357	
		35	5332	5592	5482	5467	5271	
		40	5399	5701	5559	5455	5441	
		45	5647	5471	5674	5533	5639	
		50	5684	5656	5609	5622	5475	
		55	5352	5296	5477	5538	5426	
		60	5657	5573	5291	5715	5345	
		65	5641	5530	5356	5287	5263	
		70	5679	5591	5502	5434	5668	
		75	5447	5547	5721	5629	5632	
		80	5521	5687	5463	5711	5663	
		85	5286	5462	5720	5276	5667	
		90	5564	5392	5451	5552	5555	
		95	5491	5652	5630	5269	5265	

Type 6 Radar Waveform_4

Download	4	Type 6	1.0	333.3	9	0.3333	300.0000000	13
		Frequency List (MHz)	0	1	2	3	4	
		0	5666	5251	5476	5292	5493	
		5	5486	5294	5584	5647	5481	
		10	5678	5644	5369	5282	5358	
		15	5694	5262	5643	5636	5318	
		20	5430	5646	5641	5257	5354	
		25	5437	5250	5723	5376	5705	
		30	5712	5326	5503	5598	5295	
		35	5545	5650	5407	5485	5506	
		40	5321	5684	5639	5698	5391	
		45	5435	5524	5464	5409	5340	
		50	5260	5270	5432	5469	5663	
		55	5306	5296	5458	5667	5591	
		60	5699	5488	5496	5538	5580	
		65	5265	5498	5537	5359	5724	
		70	5682	5343	5478	5393	5637	
		75	5546	5528	5264	5413	5588	
		80	5275	5460	5431	5566	5669	
		85	5346	5557	5685	5327	5440	
		90	5287	5717	5333	5661	5258	
		95	5271	5475	5671	5690	5389	

Type 6 Radar Waveform_5

Download	5	Type 6	1.0	333.3	9	0.3333	300.0000000	11
		Frequency List (MHz)	0	1	2	3	4	
		0	5349	5490	5412	5356	5335	
		5	5528	5694	5659	5713	5310	
		10	5609	5433	5410	5380	5379	
		15	5307	5389	5271	5681	5510	
		20	5438	5715	5582	5724	5424	
		25	5325	5674	5451	5577	5264	
		30	5279	5690	5460	5338	5544	
		35	5365	5314	5595	5521	5260	
		40	5517	5635	5255	5622	5404	
		45	5695	5320	5415	5607	5666	
		50	5480	5351	5663	5516	5311	
		55	5456	5633	5413	5676	5493	
		60	5332	5321	5281	5644	5322	
		65	5658	5340	5616	5572	5293	
		70	5667	5454	5352	5509	5636	
		75	5275	5277	5669	5457	5626	
		80	5566	5511	5309	5274	5553	
		85	5688	5722	5723	5482	5593	
		90	5673	5686	5601	5717	5426	
		95	5605	5374	5471	5647	5417	

Type 6 Radar Waveform_6

Download	6	Type 6	1.0	333.3	9	0.3333	300.0000000	17
		Frequency List (MHz)	0	1	2	3	4	
		0	5604	5254	5348	5517	5555	
		5	5570	5716	5259	5401	5443	
		10	5697	5451	5575	5400	5298	
		15	5516	5374	5251	5702	5349	
		20	5406	5523	5338	5397	5591	
		25	5526	5654	5681	5418	5676	
		30	5417	5553	5696	5563	5356	
		35	5686	5317	5413	5431	5571	
		40	5560	5644	5692	5627	5395	
		45	5690	5724	5533	5616	5539	
		50	5362	5545	5456	5260	5467	
		55	5689	5391	5312	5303	5353	
		60	5446	5589	5720	5701	5562	
		65	5289	5652	5307	5618	5600	
		70	5318	5310	5430	5311	5478	
		75	5304	5490	5527	5387	5450	
		80	5441	5498	5454	5469	5369	
		85	5518	5710	5461	5305	5412	
		90	5475	5703	5656	5421	5584	
		95	5477	5493	5566	5384	5250	

Type 6 Radar Waveform_7

Download	7	Type 6	1.0	333.3	9	0.3333	300.0000000	16
		Frequency List (MHz)	0	1	2	3	4	
		0	5384	5493	5284	5678	5397	
		5	5709	5641	5334	5564	5724	
		10	5374	5583	5492	5295	5421	
		15	5386	5643	5477	5296	5516	
		20	5357	5475	5561	5330	5370	
		25	5479	5378	5382	5310	5332	
		30	5460	5565	5671	5470	5383	
		35	5495	5302	5685	5566	5345	
		40	5410	5518	5498	5312	5311	
		45	5556	5375	5298	5307	5586	
		50	5503	5415	5393	5413	5634	
		55	5279	5679	5655	5581	5606	
		60	5274	5482	5611	5534	5459	
		65	5546	5647	5288	5713	5591	
		70	5614	5455	5294	5304	5313	
		75	5365	5309	5270	5350	5568	
		80	5497	5706	5605	5451	5638	
		85	5372	5292	5286	5612	5577	
		90	5260	5453	5319	5720	5711	
		95	5466	5580	5691	5661	5596	

Type 6 Radar Waveform_8

Download	3	Type 6	1.0	333.3	9	0.3333	300.0000000	7
		Frequency List (MHz)	0	1	2	3	4	
		0	5639	5257	5695	5364	5617	
		5	5276	5663	5409	5252	5456	
		10	5683	5372	5533	5490	5442	
		15	5474	5295	5483	5719	5708	
		20	5365	5641	5502	5419	5343	
		25	5367	5327	5585	5414	5366	
		30	5454	5331	5411	5622	5678	
		35	5634	5393	5481	5341	5356	
		40	5724	5601	5339	5552	5308	
		45	5485	5258	5381	5268	5293	
		50	5291	5569	5464	5723	5577	
		55	5526	5368	5597	5296	5425	
		60	5720	5611	5301	5576	5388	
		65	5593	5586	5662	5627	5349	
		70	5250	5699	5290	5413	5592	
		75	5285	5704	5319	5493	5549	
		80	5459	5510	5487	5672	5624	
		85	5351	5358	5609	5392	5278	
		90	5715	5385	5323	5267	5363	
		95	5428	5359	5692	5445	5659	

Type 6 Radar Waveform_9

Download	9	Type 6	1.0	333.3	9	0.3333	300.0000000	19
		Frequency List (MHz)	0	1	2	3	4	
		0	5322	5496	5631	5525	5362	
		5	5318	5588	5484	5285	5614	
		10	5636	5574	5463	5562	5325	
		15	5586	5289	5425	5276	5710	
		20	5443	5508	5316	5633	5654	
		25	5313	5615	5400	5641	5440	
		30	5288	5626	5396	5401	5298	
		35	5277	5494	5270	5563	5684	
		40	5317	5305	5713	5464	5326	
		45	5692	5655	5545	5515	5434	
		50	5303	5470	5556	5551	5486	
		55	5622	5594	5265	5466	5521	
		60	5695	5295	5539	5312	5611	
		65	5566	5656	5617	5405	5535	
		70	5373	5416	5441	5261	5663	
		75	5666	5530	5711	5620	5268	
		80	5361	5309	5348	5553	5275	
		85	5548	5355	5694	5291	5432	
		90	5369	5424	5499	5537	5376	
		95	5346	5590	5327	5311	5709	

Type 6 Radar Waveform_10

Download	10	Type 6	1.0	333.3	9	0.3333	300.0000000	21
		Frequency List (MHz)	0	1	2	3	4	
		0	5577	5260	5567	5686	5679	
		5	5360	5610	5559	5481	5492	
		10	5545	5425	5615	5308	5484	
		15	5553	5452	5689	5334	5617	
		20	5284	5401	5384	5500	5289	
		25	5521	5603	5419	5719	5434	
		30	5683	5329	5720	5366	5548	
		35	5696	5340	5672	5647	5659	
		40	5402	5292	5690	5460	5302	
		45	5721	5893	5547	5270	5445	
		50	5421	5446	5566	5523	5601	
		55	5317	5269	5505	5579	5441	
		60	5565	5394	5631	5466	5527	
		65	5596	5582	5513	5560	5602	
		70	5391	5412	5607	5359	5516	
		75	5290	5712	5622	5635	5597	
		80	5682	5511	5488	5255	5524	
		85	5525	5372	5345	5273	5653	
		90	5390	5415	5406	5341	5375	
		95	5458	5549	5393	5259	5306	

Type 6 Radar Waveform_11

Download	11	Type 6	1.0	333.3	9	0.3333	300.0000000	13
		Frequency List (MHz)	0	1	2	3	4	
		0	5357	5499	5503	5372	5424	
		5	5535	5634	5644	5699	5379	
		10	5689	5656	5505	5641	5579	
		15	5317	5334	5292	5470	5422	
		20	5589	5262	5312	5455	5622	
		25	5348	5468	5250	5693	5677	
		30	5484	5322	5419	5479	5288	
		35	5441	5670	5338	5472	5628	
		40	5700	5299	5553	5673	5630	
		45	5345	5701	5332	5297	5617	
		50	5612	5261	5457	5459	5294	
		55	5260	5536	5426	5321	5411	
		60	5359	5528	5336	5509	5638	
		65	5698	5682	5486	5679	5519	
		70	5614	5688	5581	5604	5717	
		75	5253	5492	5265	5268	5305	
		80	5435	5342	5565	5653	5329	
		85	5378	5660	5527	5296	5654	
		90	5539	5287	5381	5395	5658	
		95	5410	5456	5340	5386	5663	

Type 6 Radar Waveform_12

Download	12	Type 6	1. 0	333. 3	9	0. 3333	300. 0000000	18
		Frequency List (MHz)	0	1	2	3	4	
		0	5612	5263	5439	5533	5266	
		5	5541	5557	5709	5332	5528	
		10	5310	5478	5319	5698	5526	
		15	5254	5706	5420	5327	5678	
		20	5636	5363	5581	5710	5675	
		25	5307	5350	5452	5502	5389	
		30	5679	5634	5699	5474	5714	
		35	5618	5379	5712	5575	5584	
		40	5652	5555	5566	5485	5393	
		45	5482	5653	5713	5403	5279	
		50	5597	5551	5323	5668	5701	
		55	5722	5583	5548	5413	5484	
		60	5457	5507	5486	5453	5666	
		65	5345	5537	5458	5577	5433	
		70	5574	5289	5373	5428	5619	
		75	5463	5664	5443	5476	5362	
		80	5396	5473	5517	5378	5561	
		85	5281	5498	5339	5285	5556	
		90	5646	5341	5377	5492	5250	
		95	5427	5359	5429	5523	5292	

Type 6 Radar Waveform_13

Download	13	Type 6	1. 0	333. 3	9	0. 3333	300. 0000000	16
		Frequency List (MHz)	0	1	2	3	4	
		0	5295	5502	5375	5597	5486	
		5	5583	5482	5309	5398	5260	
		10	5716	5364	5360	5418	5547	
		15	5342	5358	5426	5372	5718	
		20	5686	5327	5304	5670	5683	
		25	5466	5256	5553	5653	5536	
		30	5431	5568	5591	5439	5723	
		35	5437	5660	5470	5508	5253	
		40	5498	5491	5638	5504	5705	
		45	5390	5411	5633	5321	5461	
		50	5332	5484	5427	5499	5719	
		55	5315	5448	5527	5261	5270	
		60	5674	5276	5381	5684	5651	
		65	5595	5646	5517	5407	5613	
		70	5265	5369	5567	5445	5414	
		75	5622	5690	5543	5402	5442	
		80	5454	5672	5488	5658	5714	
		85	5480	5459	5401	5569	5301	
		90	5675	5557	5617	5490	5463	
		95	5308	5541	5566	5279	5621	

Type 6 Radar Waveform_14

Download	14	Type 6	1.0	333.3	9	0.3333	300.0000000	16
		Frequency List (MHz)	0	1	2	3	4	
		0	5550	5266	5311	5283	5328	
		5	5625	5504	5384	5561	5467	
		10	5628	5401	5516	5568	5333	
		15	5388	5529	5417	5532	5694	
		20	5396	5342	5662	5656	5354	
		25	5583	5281	5282	5570	5473	
		30	5554	5548	5654	5400	5257	
		35	5324	5503	5509	5330	5343	
		40	5442	5373	5387	5718	5404	
		45	5422	5385	5274	5303	5675	
		50	5295	5501	5271	5374	5449	
		55	5699	5389	5352	5338	5341	
		60	5427	5569	5463	5356	5649	
		65	5475	5261	5273	5614	5722	
		70	5539	5519	5361	5317	5602	
		75	5585	5435	5598	5609	5721	
		80	5711	5459	5364	5664	5325	
		85	5255	5351	5377	5307	5496	
		90	5665	5413	5558	5621	5652	
		95	5371	5657	5655	5588	5322	

Type 6 Radar Waveform_15

Download	15	Type 6	1.0	333.3	9	0.3333	300.0000000	13
		Frequency List (MHz)	0	1	2	3	4	
		0	5330	5505	5722	5444	5548	
		5	5289	5429	5362	5724	5296	
		10	5481	5417	5442	5711	5589	
		15	5421	5515	5632	5462	5605	
		20	5562	5283	5276	5629	5717	
		25	5532	5387	5386	5604	5443	
		30	5408	5297	5649	5552	5463	
		35	5652	5672	5656	5423	5266	
		40	5426	5380	5613	5384	5647	
		45	5496	5487	5480	5438	5636	
		50	5654	5376	5346	5590	5569	
		55	5318	5637	5653	5579	5389	
		60	5323	5467	5506	5288	5259	
		65	5395	5409	5305	5588	5307	
		70	5531	5551	5686	5250	5388	
		75	5495	5320	5286	5625	5253	
		80	5416	5701	5611	5379	5298	
		85	5309	5708	5269	5424	5381	
		90	5668	5306	5599	5575	5472	
		95	5502	5434	5450	5522	5676	

Type 6 Radar Waveform_16

Download	16	Type 6	1.0	333.3	9	0.3333	300.0000000	10
		Frequency List (MHz)	0	1	2	3	4	
		0	5585	5366	5658	5605	5390	
		5	5331	5451	5437	5412	5503	
		10	5681	5483	5431	5610	5509	
		15	5642	5260	5410	5441	5613	
		20	5631	5699	5268	5602	5508	
		25	5384	5590	5490	5638	5654	
		30	5332	5365	5512	5326	5275	
		35	5468	5334	5337	5580	5696	
		40	5378	5381	5479	5476	5570	
		45	5538	5491	5426	5433	5552	
		50	5397	5679	5392	5640	5350	
		55	5607	5294	5586	5596	5671	
		60	5330	5566	5355	5254	5624	
		65	5517	5354	5380	5469	5253	
		70	5712	5471	5279	5633	5270	
		75	5299	5478	5635	5705	5687	
		80	5265	5387	5372	5395	5637	
		85	5371	5534	5592	5256	5357	
		90	5448	5364	5557	5389	5604	
		95	5578	5386	5663	5720	5449	

Type 6 Radar Waveform_17

Download	17	Type 6	1.0	333.3	9	0.3333	300.0000000	12
		Frequency List (MHz)	0	1	2	3	4	
		0	5365	5605	5594	5291	5610	
		5	5373	5376	5512	5478	5710	
		10	5721	5470	5524	5626	5631	
		15	5597	5294	5363	5455	5633	
		20	5621	5322	5262	5357	5575	
		25	5396	5711	5318	5691	5672	
		30	5696	5252	5570	5644	5456	
		35	5264	5584	5348	5419	5592	
		40	5634	5618	5475	5408	5653	
		45	5499	5544	5313	5309	5253	
		50	5448	5293	5690	5538	5561	
		55	5387	5405	5643	5628	5361	
		60	5275	5495	5619	5398	5311	
		65	5678	5563	5349	5693	5632	
		70	5452	5353	5464	5447	5713	
		75	5602	5390	5442	5255	5259	
		80	5416	5529	5532	5702	5407	
		85	5265	5525	5668	5501	5620	
		90	5593	5327	5611	5706	5438	
		95	5346	5343	5660	5587	5370	

Type 6 Radar Waveform_18

Download	18	Type 6	1. 0	333. 3	9	0. 3333	300. 0000000	18
		Frequency List (MHz)	0	1	2	3	4	
		0	5523	5369	5530	5452	5512	
		5	5398	5587	5641	5539	5652	
		10	5356	5565	5346	5588	5421	
		15	5500	5350	5532	5391	5678	
		20	5349	5548	5662	5660	5521	
		25	5320	5706	5263	5682	5279	
		30	5467	5252	5293	5308	5547	
		35	5632	5262	5258	5297	5572	
		40	5286	5472	5715	5436	5261	
		45	5557	5578	5429	5499	5479	
		50	5416	5431	5629	5515	5577	
		55	5699	5614	5282	5526	5695	
		60	5327	5445	5344	5609	5627	
		65	5599	5559	5488	5435	5621	
		70	5441	5313	5423	5672	5474	
		75	5510	5456	5507	5693	5595	
		80	5602	5643	5367	5410	5385	
		85	5466	5265	5393	5413	5492	
		90	5617	5342	5277	5723	5366	
		95	5422	5719	5700	5288	5310	

Type 6 Radar Waveform_19

Download	19	Type 6	1. 0	333. 3	9	0. 3333	300. 0000000	15
		Frequency List (MHz)	0	1	2	3	4	
		0	5303	5608	5466	5613	5672	
		5	5554	5420	5662	5329	5271	
		10	5486	5620	5606	5444	5673	
		15	5676	5451	5472	5448	5542	
		20	5540	5557	5619	5438	5521	
		25	5550	5512	5724	5424	5643	
		30	5402	5571	5711	5585	5501	
		35	5588	5447	5638	5428	5415	
		40	5651	5572	5380	5510	5526	
		45	5469	5644	5416	5441	5615	
		50	5553	5465	5536	5508	5568	
		55	5714	5375	5342	5292	5421	
		60	5411	5691	5262	5634	5290	
		65	5335	5576	5635	5391	5616	
		70	5693	5427	5456	5637	5302	
		75	5631	5443	5630	5437	5382	
		80	5453	5658	5599	5322	5546	
		85	5306	5470	5480	5334	5694	
		90	5641	5611	5657	5623	5376	
		95	5356	5289	5265	5406	5679	

Type 6 Radar Waveform_20

Download	20	Type 6	1.0	333.3	9	0.3333	300.0000000	17
		Frequency List (MHz)	0	1	2	3	4	
		0	5558	5372	5402	5677	5514	
		5	5596	5345	5262	5492	5478	
		10	5417	5409	5269	5639	5694	
		15	5289	5578	5575	5493	5259	
		20	5548	5626	5657	5430	5494	
		25	5341	5461	5355	5528	5444	
		30	5557	5668	5325	5653	5311	
		35	5489	5254	5699	5665	5662	
		40	5508	5463	5448	5291	5466	
		45	5573	5396	5524	5576	5606	
		50	5255	5315	5684	5601	5537	
		55	5697	5530	5423	5482	5715	
		60	5556	5540	5381	5682	5669	
		65	5333	5633	5525	5574	5650	
		70	5419	5290	5510	5459	5486	
		75	5278	5590	5412	5418	5439	
		80	5709	5449	5343	5614	5546	
		85	5623	5433	5672	5299	5270	
		90	5414	5334	5347	5629	5313	
		95	5616	5398	5282	5476	5487	

Type 6 Radar Waveform_21

Download	21	Type 6	1.0	333.3	9	0.3333	300.0000000	15
		Frequency List (MHz)	0	1	2	3	4	
		0	5338	5611	5363	5259	5636	
		5	5367	5337	5558	5307	5348	
		10	5673	5310	5359	5715	5377	
		15	5705	5678	5538	5451	5459	
		20	5317	5598	5519	5467	5704	
		25	5313	5254	5711	5486	5446	
		30	5625	5540	5427	5606	5628	
		35	5442	5592	5343	5576	5347	
		40	5546	5386	5434	5463	5405	
		45	5279	5607	5634	5659	5617	
		50	5666	5385	5652	5271	5360	
		55	5641	5718	5672	5534	5430	
		60	5669	5627	5298	5495	5474	
		65	5610	5433	5445	5697	5496	
		70	5559	5335	5549	5284	5345	
		75	5399	5691	5602	5490	5613	
		80	5406	5593	5334	5449	5465	
		85	5493	5292	5642	5699	5665	
		90	5629	5415	5257	5498	5410	
		95	5396	5531	5471	5510	5597	

Type 6 Radar Waveform_22

Download	22	Type 6	1.0	333.3	9	0.3333	300.0000000	17
		Frequency List (MHz)	0	1	2	3	4	
		0	5496	5375	5274	5524	5576	
		5	5302	5292	5412	5721	5514	
		10	5657	5462	5351	5554	5261	
		15	5368	5357	5306	5583	5285	
		20	5467	5386	5539	5511	5440	
		25	5592	5640	5286	5358	5270	
		30	5625	5432	5582	5280	5579	
		35	5426	5533	5388	5490	5661	
		40	5251	5324	5674	5557	5334	
		45	5259	5690	5692	5712	5407	
		50	5542	5561	5703	5360	5488	
		55	5431	5331	5387	5353	5401	
		60	5701	5711	5572	5702	5418	
		65	5700	5423	5549	5643	5337	
		70	5500	5531	5482	5562	5705	
		75	5508	5253	5391	5380	5468	
		80	5615	5271	5469	5590	5529	
		85	5352	5404	5456	5484	5607	
		90	5275	5338	5580	5263	5381	
		95	5283	5519	5413	5586	5455	

Type 6 Radar Waveform_23

Download	23	Type 6	1.0	333.3	9	0.3333	300.0000000	17
		Frequency List (MHz)	0	1	2	3	4	
		0	5276	5614	5685	5321	5344	
		5	5314	5487	5409	5721	5588	
		10	5348	5392	5274	5282	5456	
		15	5484	5312	5531	5457	5475	
		20	5552	5480	5600	5413	5383	
		25	5589	5489	5462	5304	5667	
		30	5539	5398	5353	5624	5431	
		35	5659	5271	5501	5500	5334	
		40	5640	5439	5554	5641	5714	
		45	5298	5653	5290	5294	5418	
		50	5262	5279	5546	5384	5432	
		55	5619	5285	5577	5550	5372	
		60	5355	5401	5534	5719	5646	
		65	5585	5607	5303	5700	5468	
		70	5565	5411	5681	5467	5538	
		75	5361	5720	5250	5527	5466	
		80	5532	5587	5724	5352	5516	
		85	5676	5704	5586	5647	5270	
		90	5269	5318	5628	5430	5544	
		95	5536	5306	5328	5543	5702	

Type 6 Radar Waveform_24

Download	24	Type 6	1. 0	333. 3	9	0. 3333	300. 0000000	21
		Frequency List (MHz)	0	1	2	3	4	
		0	5531	5378	5621	5371	5638	
		5	5386	5714	5562	5572	5453	
		10	5519	5612	5433	5372	5303	
		15	5544	5514	5415	5576	5649	
		20	5718	5518	5592	5271	5441	
		25	5692	5566	5338	5709	5685	
		30	5496	5613	5505	5444	5473	
		35	5715	5455	5424	5436	5417	
		40	5578	5679	5551	5570	5694	
		45	5381	5711	5721	5559	5672	
		50	5438	5330	5635	5682	5279	
		55	5332	5670	5369	5343	5484	
		60	5366	5545	5689	5681	5321	
		65	5499	5297	5665	5260	5560	
		70	5426	5569	5561	5677	5342	
		75	5400	5360	5308	5533	5487	
		80	5255	5563	5479	5296	5280	
		85	5359	5370	5435	5275	5352	
		90	5522	5640	5447	5599	5520	
		95	5380	5431	5267	5497	5538	

Type 6 Radar Waveform_25

Download	25	Type 6	1. 0	333. 3	9	0. 3333	300. 0000000	17
		Frequency List (MHz)	0	1	2	3	4	
		0	5311	5617	5557	5532	5383	
		5	5428	5261	5637	5260	5282	
		10	5353	5401	5474	5567	5324	
		15	5632	5641	5518	5621	5366	
		20	5394	5312	5459	5681	5359	
		25	5537	5390	5323	5670	5372	
		30	5373	5671	5453	5279	5642	
		35	5612	5331	5348	5577	5329	
		40	5275	5597	5516	5347	5548	
		45	5499	5674	5464	5294	5299	
		50	5446	5614	5381	5724	5505	
		55	5698	5423	5571	5385	5663	
		60	5692	5613	5256	5504	5673	
		65	5468	5635	5407	5270	5560	
		70	5517	5287	5466	5668	5584	
		75	5536	5441	5723	5652	5564	
		80	5697	5280	5484	5633	5502	
		85	5442	5488	5308	5709	5607	
		90	5665	5600	5281	5289	5307	
		95	5274	5654	5262	5534	5562	

Type 6 Radar Waveform_26

Download	26	Type 6	1.0	333.3	9	0.3333	300.0000000	18
		Frequency List (MHz)	0	1	2	3	4	
		0	5566	5381	5493	5693	5700	
		5	5567	5661	5712	5326	5489	
		10	5284	5665	5515	5287	5345	
		15	5720	5293	5621	5666	5558	
		20	5402	5478	5400	5673	5332	
		25	5425	5717	5526	5396	5406	
		30	5415	5560	5410	5568	5431	
		35	5462	5276	5519	5619	5352	
		40	5718	5589	5680	5454	5587	
		45	5545	5331	5654	5547	5255	
		50	5711	5424	5315	5432	5338	
		55	5706	5611	5525	5575	5385	
		60	5663	5267	5421	5449	5505	
		65	5294	5581	5608	5694	5596	
		70	5252	5565	5538	5523	5433	
		75	5512	5344	5391	5401	5429	
		80	5483	5442	5386	5343	5481	
		85	5456	5633	5502	5651	5285	
		90	5380	5388	5290	5384	5323	
		95	5664	5383	5578	5709	5585	

Type 6 Radar Waveform_27

Download	27	Type 6	1.0	333.3	9	0.3333	300.0000000	14
		Frequency List (MHz)	0	1	2	3	4	
		0	5724	5620	5429	5379	5445	
		5	5609	5683	5312	5489	5696	
		10	5690	5454	5556	5482	5366	
		15	5711	5420	5614	5275	5313	
		20	5547	5438	5287	5305	5691	
		25	5569	5254	5500	5440	5457	
		30	5449	5367	5686	5680	5660	
		35	5318	5610	5415	5505	5428	
		40	5288	5392	5352	5639	5260	
		45	5537	5630	5405	5598	5678	
		50	5491	5483	5524	5529	5324	
		55	5479	5290	5679	5634	5299	
		60	5586	5434	5595	5624	5431	
		65	5643	5535	5559	5456	5368	
		70	5707	5606	5296	5488	5303	
		75	5282	5446	5437	5382	5681	
		80	5496	5698	5550	5503	5478	
		85	5651	5536	5283	5465	5300	
		90	5616	5714	5628	5455	5390	
		95	5395	5289	5470	5265	5554	

Type 6 Radar Waveform_28

Download	28	Type 6	1.0	333.3	9	0.3333	300.0000000	16
		Frequency List (MHz)	0	1	2	3	4	
		0	5504	5384	5365	5443	5287	
		5	5651	5608	5387	5652	5525	
		10	5524	5340	5694	5677	5324	
		15	5450	5255	5659	5467	5321	
		20	5713	5379	5279	5278	5579	
		25	5518	5457	5604	5474	5499	
		30	5435	5426	5357	5480	5701	
		35	5308	5658	5643	5267	5371	
		40	5330	5592	5636	5567	5517	
		45	5458	5388	5554	5667	5534	
		50	5613	5352	5336	5512	5433	
		55	5498	5605	5428	5276	5436	
		60	5266	5570	5632	5571	5294	
		65	5251	5646	5304	5396	5509	
		70	5464	5262	5566	5580	5363	
		75	5606	5479	5617	5475	5439	
		80	5600	5492	5484	5290	5401	
		85	5406	5620	5331	5612	5344	
		90	5553	5368	5577	5303	5649	
		95	5395	5275	5412	5640	5555	

Type 6 Radar Waveform_29

Download	29	Type 6	1.0	333.3	9	0.3333	300.0000000	12
		Frequency List (MHz)	0	1	2	3	4	
		0	5284	5623	5301	5604	5507	
		5	5693	5630	5462	5340	5257	
		10	5455	5260	5300	5408	5412	
		15	5577	5358	5704	5659	5329	
		20	5307	5320	5368	5251	5467	
		25	5370	5660	5708	5508	5638	
		30	5324	5281	5641	5606	5596	
		35	5317	5579	5433	5557	5678	
		40	5551	5268	5633	5496	5497	
		45	5321	5429	5511	5275	5430	
		50	5585	5702	5650	5280	5700	
		55	5387	5670	5479	5441	5381	
		60	5573	5344	5516	5541	5607	
		65	5601	5618	5352	5473	5578	
		70	5399	5440	5696	5695	5589	
		75	5626	5710	5716	5306	5629	
		80	5375	5566	5439	5442	5488	
		85	5587	5449	5719	5552	5701	
		90	5310	5402	5706	5688	5613	
		95	5634	5266	5459	5471	5501	

Appendix B – Test Setup Photograph

Refer to “2212RSU034-UT” file.

Appendix C – EUT Photograph

Refer to “2212RSU034-UE” file.

_____ The End _____