

Company: Aruba Networks, Inc.

Test of: APIN0314 & APIN0315 Wireless Access Point

To: FCC Part 15.247 (DTS) & IC RSS-247

Report No.: ARUB204-U2 Rev A Bluetooth BLE

TEST REPORT





Test of: Aruba Networks, Inc. APIN0314 & APIN0315

to

To: FCC CFR 47 Part 15 Subpart C 15.247 (DTS) & IC RSS-247

Test Report Serial No.: ARUB204-U2 Rev A Bluetooth BLE

Note: this report contains data with regard to 2400-2483.5 MHz Bluetooth BLE operational mode of the Aruba Networks APIN0314 and APIN0315 Wireless Access Point. Additional 802.11 modes for this product are reported in the following MiCOM Labs test reports 2400-2483.5 MHz ARUB204-U5, UNII-1 & UNII-3 ARUB204-U8 and UNII-2A and UNII-2C (DFS Bands) ARUB204-U10.

This report supersedes: NONE

Applicant: Aruba Networks, Inc.
1344 Crossman Ave.
Sunnyvale California 94089
USA

Product Function: Wireless Access Point

Issue Date: 12th April 2016

This Test Report is Issued Under the Authority of:

MiCOM Labs, Inc.
575 Boulder Court
Pleasanton California 94566
USA
Phone: +1 (925) 462-0304
Fax: +1 (925) 462-0306
www.micomlabs.com



MiCOM Labs is an ISO 17025 Accredited Testing Laboratory



Table of Contents

1. ACCREDITATION, LISTINGS & RECOGNITION.....	4
1.1. Testing Accreditation	4
1.2. Recognition.....	5
1.3. Product Certification	6
2. DOCUMENT HISTORY	7
3. TEST RESULT CERTIFICATE.....	8
4. REFERENCES AND MEASUREMENT UNCERTAINTY	9
4.1. Normative References	9
4.2. Test and Uncertainty Procedure	10
5. PRODUCT DETAILS AND TEST CONFIGURATIONS.....	11
5.1. Technical Details	11
5.2. Scope Of Test Program	12
5.3. Equipment Model(s) and Serial Number(s).....	14
5.4. Antenna Details	14
5.5. Cabling and I/O Ports	14
5.6. Test Configurations.....	14
5.7. Equipment Modifications	15
5.8. Deviations from the Test Standard	15
6. TEST SUMMARY	16
7. TEST EQUIPMENT CONFIGURATION(S)	17
7.1. Conducted	17
7.2. Radiated Spurious Emissions.....	19
8. MEASUREMENT AND PRESENTATION OF TEST DATA	21
9. TEST RESULTS	22
9.1. 6 dB & 99% Bandwidth	22
9.2. Conducted Output Power	24
9.3. Conducted Spurious Emissions.....	27
9.3.1. Conducted Spurious Emissions	27
9.3.2. Conducted Band-Edge Emissions	29
<i>Low Band-Edge Emissions</i>	29
<i>High Band-Edge Emissions</i>	30
9.4. Power Spectral Density	31
9.5. Radiated Emissions.....	33
9.5.1. Restricted Band Emissions	36
9.5.2. Restricted Band-Edge Emissions	39
APPENDIX A - GRAPHICAL IMAGES	41
A.1. 6 dB & 99% Bandwidth	42
A.2. Conducted Output Power	46
A.3. Emissions	49
A.3.1. Conducted Emissions	49
A.3.1.1. Conducted Spurious Emissions	49
A.3.1.2. Conducted Band-Edge Emissions	52
A.4. Power Spectral Density	54
A.5. Radiated Spurious Emissions	57
A.5.1. Restricted Band Emissions.....	57
A.5.2. Restricted Band-Edge Emissions	60

This test report may be reproduced in full only. The document may only be updated by MiCOM Labs personnel. All changes will be noted in the Document History section of the report.

1. ACCREDITATION, LISTINGS & RECOGNITION

1.1. Testing Accreditation

MiCOM Labs, Inc. is an accredited Electrical testing laboratory per the international standard ISO/IEC 17025:2005. The company is accredited by the American Association for Laboratory Accreditation (A2LA) www.a2la.org test laboratory number 2381.01. MiCOM Labs test schedule is available at the following URL; <http://www.a2la.org/scopepdf/2381-01.pdf>



Accredited Laboratory

A2LA has accredited

MICOM LABS

Pleasanton, CA

for technical competence in the field of

Electrical Testing

This laboratory is accredited in accordance with the recognized International Standard ISO/IEC 17025:2005 General requirements for the competence of testing and calibration laboratories. This accreditation demonstrates technical competence for a defined scope and the operation of a laboratory quality management system (refer to joint ISO-ILAC-IAF Communiqué dated 8 January 2009).



Presented this 4th day of February 2016.

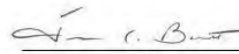

Senior Director of Quality & Communications
For the Accreditation Council
Certificate Number 2381.01
Valid to November 30, 2017

For the tests or types of tests to which this accreditation applies, please refer to the laboratory's Electrical Scope of Accreditation.

This test report may be reproduced in full only. The document may only be updated by MiCOM Labs personnel. All changes will be noted in the Document History section of the report.



Title: Aruba Networks, Inc. APIN0314 & APIN0315
To: FCC Part 15.247 (DTS) & IC RSS-247
Serial #: ARUB204-U2 Rev A Bluetooth BLE
Issue Date: 4th April 2016
Page: 5 of 62

1.2. Recognition

MiCOM Labs, Inc has widely recognized wireless testing capabilities. Our international recognition includes Conformity Assessment Body designation by APEC MRA countries. MiCOM Labs test reports are accepted globally.

Country	Recognition Body	Status	Phase	Identification No.
USA	Federal Communications Commission (FCC)	TCB	-	US0159 Listing #: 102167
Canada	Industry Canada (IC)	FCB	APEC MRA 2	US0159 Listing #: 4143A-2 4143A-3
Japan	MIC (Ministry of Internal Affairs and Communication)	CAB	APEC MRA 2	RCB 210
	VCCI	--	--	A-0012
Europe	European Commission	NB	EU MRA	NB 2280
Australia	Australian Communications and Media Authority (ACMA)	CAB	APEC MRA 1	US0159
Hong Kong	Office of the Telecommunication Authority (OFTA)	CAB	APEC MRA 1	
Korea	Ministry of Information and Communication Radio Research Laboratory (RRL)	CAB	APEC MRA 1	
Singapore	Infocomm Development Authority (IDA)	CAB	APEC MRA 1	
Taiwan	National Communications Commission (NCC) Bureau of Standards, Metrology and Inspection (BSMI)	CAB	APEC MRA 1	
Vietnam	Ministry of Communication (MIC)	CAB	APEC MRA 1	

EU MRA – European Union Mutual Recognition Agreement.

NB – Notified Body

APEC MRA – Asia Pacific Economic Community Mutual Recognition Agreement. Recognition agreement under which test lab is accredited to regulatory standards of the APEC member countries.

Phase I - recognition for product testing

Phase II – recognition for both product testing and certification

This test report may be reproduced in full only. The document may only be updated by MiCOM Labs personnel. All changes will be noted in the Document History section of the report.

1.3. Product Certification

MiCOM Labs, Inc. is an accredited Product Certification Body per the international standard ISO/IEC 17065:2012. The company is accredited by the American Association for Laboratory Accreditation (A2LA) www.a2la.org test laboratory number 2381.02. MiCOM Labs test schedule is available at the following URL; <http://www.a2la.org/scopepdf/2381-02.pdf>



The certificate features a central title "Accredited Product Certification Body" in blue. Above it are the logos for IAF (International Accreditation Forum) and A2LA (American Association for Laboratory Accreditation). Below the title, it states "A2LA has accredited MICOM LABS, Pleasanton, CA". A paragraph explains the accreditation according to ISO/IEC 17065:2012. To the left is a yellow circular seal with "A2LA" and "CORPORATE SEAL 1978". To the right is a signature and the name "Senior Director of Quality & Communications" with certificate details. The bottom of the certificate includes a note about the scope of accreditation.

United States of America – Telecommunication Certification Body (TCB)
Industry Canada – Certification Body, CAB Identifier – US0159
Europe – Notified Body (NB), NB Identifier - 2280
Japan – Recognized Certification Body (RCB), RCB Identifier - 210



Title: Aruba Networks, Inc. APIN0314 & APIN0315
To: FCC Part 15.247 (DTS) & IC RSS-247
Serial #: ARUB204-U2 Rev A Bluetooth BLE
Issue Date: 4th April 2016
Page: 7 of 62

2. DOCUMENT HISTORY

Document History		
Revision	Date	Comments
Draft	29 th March 2016	
Rev A	12 th April 2016	Initial Release

In the above table the latest report revision will replace all earlier versions.

This test report may be reproduced in full only. The document may only be updated by MiCOM Labs personnel. All changes will be noted in the Document History section of the report.



Title: Aruba Networks, Inc. APIN0314 & APIN0315
To: FCC Part 15.247 (DTS) & IC RSS-247
Serial #: ARUB204-U2 Rev A Bluetooth BLE
Issue Date: 4th April 2016
Page: 8 of 62

3. TEST RESULT CERTIFICATE

Manufacturer: Aruba Networks, Inc. 1344 Crossman Ave. Sunnyvale California 94089 USA	Tested By: MiCOM Labs, Inc. 575 Boulder Court Pleasanton California 94566 USA
Model: APIN0314, APIN0315	Telephone: +1 925 462 0304
Equipment Type: Wireless Access Point with Bluetooth BLE	Fax: +1 925 462 0306
S/N's: DW0000541 DW0000254	
Test Date(s): 16 th - 29 th February 2016	Website: www.micomlabs.com

STANDARD(S)	TEST RESULTS
FCC CFR 47 Part 15 Subpart C 15.247 (DTS) & Industry Canada RSS-247	EQUIPMENT COMPLIES

MiCOM Labs, Inc. tested the equipment mentioned in accordance with the requirements set forth in the above standards. Test results indicate that the equipment tested is capable of demonstrating compliance with the requirements as documented within this report.

Notes:

1. This document reports conditions under which testing was conducted and the results of testing performed.
2. Details of test methods used have been recorded and kept on file by the laboratory.
3. Test results apply only to the item(s) tested.

Approved & Released for MiCOM Labs, Inc. by:



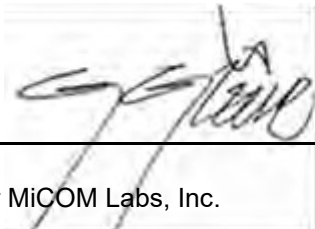

Graeme Grieve
Quality Manager MiCOM Labs, Inc.

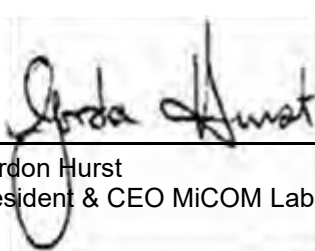

Gordon Hurst
President & CEO MiCOM Labs, Inc.

This test report may be reproduced in full only. The document may only be updated by MiCOM Labs personnel. All changes will be noted in the Document History section of the report.



Title: Aruba Networks, Inc. APIN0314 & APIN0315
To: FCC Part 15.247 (DTS) & IC RSS-247
Serial #: ARUB204-U2 Rev A Bluetooth BLE
Issue Date: 4th April 2016
Page: 9 of 62

4. REFERENCES AND MEASUREMENT UNCERTAINTY

4.1. Normative References

REF.	PUBLICATION	YEAR	TITLE
I	KDB 662911	Oct 31 2013	Guidance for measurement of output emission of devices that employ single transmitter with multiple outputs or systems with multiple transmitters operating simultaneously in the same frequency band
II	KDB 558074 D01 v03r05	8th April 2016	Guidance for performing compliance measurements on Digital Transmission Systems (DTS) operating under section 15.247.
III	A2LA	June 2015	R105 - Requirement's When Making Reference to A2LA Accreditation Status
IV	ANSI C63.10	2013	American National Standard for Testing Unlicensed Wireless Devices
V	ANSI C63.4	2009	American National Standards for Methods of Measurement of Radio-Noise Emissions from Low-Voltage Electrical and Electronic Equipment in the Range of 9 kHz to 40 GHz
VI	CISPR 22	2008	Information technology equipment - Radio disturbance characteristics - Limits and methods of measurement
VII	ETSI TR 100 028	2001-12	Parts 1 and 2 Electromagnetic compatibility and Radio Spectrum Matters (ERM); Uncertainties in the measurement of mobile radio equipment characteristics
VIII	FCC 47 CFR Part 15.247	2014	Radio Frequency Devices; Subpart C – Intentional Radiators
IX	ICES-003	Issue 6 January 2016	Spectrum Management and Telecommunications; Interference-Causing Equipment Standard. Information Technology Equipment (ITE) – Limits and methods of measurement.
X	M 3003	Edition 3 Nov. 2012	Expression of Uncertainty and Confidence in Measurements
XI	RSS-247 Issue 1	May 2015	Digital Transmission Systems (DTSs), Frequency Hopping System (FHSs) and Licence-Exempt Local Area Network (LE-LEN) Devices
XII	RSS-Gen Issue 4	November 2014	General Requirements and Information for the Certification of Radiocommunication Equipment
XIII	KDB 644545 D03 v01	August 14th 2014	Guidance for IEEE 802.11ac New Rules
XIV	FCC 47 CFR Part 2.1033	2014	FCC requirements and rules regarding photographs and test setup diagrams.

This test report may be reproduced in full only. The document may only be updated by MiCOM Labs personnel. All changes will be noted in the Document History section of the report.



Title: Aruba Networks, Inc. APIN0314 & APIN0315
To: FCC Part 15.247 (DTS) & IC RSS-247
Serial #: ARUB204-U2 Rev A Bluetooth BLE
Issue Date: 4th April 2016
Page: 10 of 62

4.2. Test and Uncertainty Procedure

Conducted and radiated emission measurements were conducted in accordance with American National Standards Institute ANSI C63.4, listed in the Normative References section of this report.

Measurement uncertainty figures are calculated in accordance with ETSI TR 100 028 Parts 1 and 2.

Measurement uncertainties stated are based on a standard uncertainty multiplied by a coverage factor $k = 2$, providing a level of confidence of approximately 95 % in accordance with UKAS document M 3003 listed in the Normative References section of this report.

This test report may be reproduced in full only. The document may only be updated by MiCOM Labs personnel. All changes will be noted in the Document History section of the report.



Title: Aruba Networks, Inc. APIN0314 & APIN0315
To: FCC Part 15.247 (DTS) & IC RSS-247
Serial #: ARUB204-U2 Rev A Bluetooth BLE
Issue Date: 4th April 2016
Page: 11 of 62

5. PRODUCT DETAILS AND TEST CONFIGURATIONS

5.1. Technical Details

Details	Description
Purpose:	Test of the Aruba Networks, Inc. APIN0314 & APIN0315 to FCC CFR 47 Part 15 Subpart C 15.247 (DTS) and Industry Canada RSS-247
Applicant:	Aruba Networks, Inc. 1344 Crossman Ave. Sunnyvale California 94089 USA
Manufacturer:	As Applicant
Laboratory performing the tests:	MiCOM Labs, Inc. 575 Boulder Court Pleasanton California 94566 USA
Test report reference number:	ARUB204-U2
Date EUT received:	16 th February 2016
Standard(s) applied:	FCC CFR 47 Part 15 Subpart C 15.247 (DTS) & Industry Canada RSS-247
Dates of test (from - to):	16 th – 29 th February 2016
No of Units Tested:	1
Type of Equipment:	802.11 a/b/g/n/ac & Bluetooth BLE
Product Family Name:	Wireless Access Point
Model(s):	APIN0314 & APIN0315
Location for use:	Indoor
Declared Frequency Range(s):	2400 - 2483.5 MHz;
Primary function of equipment:	Wireless access point
Secondary function of equipment:	None Provided
Type of Modulation:	GFSK
EUT Modes of Operation:	Bluetooth BLE
Transmit/Receive Operation:	Transceiver - Half Duplex
Rated Input Voltage and Current:	POE (POE adaptor NOT sold with unit) 55Vdc ac/dc 120 Vac 60 Hz : +12 Vdc
Operating Temperature Range:	Declared Range 0°C to 40°C
ITU Emission Designator:	1M1G1D
Equipment Dimensions:	APIN0314: 181.6mm x 180.35mm x 48mm / 7.15" x 7.1" x 1.89" APIN0315: 181.6mm x 180.35mm x 48mm / 7.15" x 7.1" x 1.89"
Weight:	APIN0314: 0.643 kg APIN0315: 0.650 kg
Hardware Rev:	Rev: 1
Software Rev:	V2.2.1

This test report may be reproduced in full only. The document may only be updated by MiCOM Labs personnel. All changes will be noted in the Document History section of the report.

5.2. Scope Of Test Program

Aruba Networks, Inc. APIN0314 & APIN0315

The scope of the test program was to test the Aruba Networks, Inc. APIN0314 & APIN0315, 802.11 a/b/g/n/ac configurations in the frequency ranges 2400 - 2483.5 MHz; for compliance against the following specification:

FCC CFR 47 Part 15 Subpart C 15.247 (DTS)

Radio Frequency Devices; Subpart C – Intentional Radiators

Industry Canada RSS-247

Digital Transmission Systems (DTSs), Frequency Hopping System (FHSs) and Licence-Exempt Local Area Network (LE-LEN) Devices

Aruba Networks, Inc. APIN0314

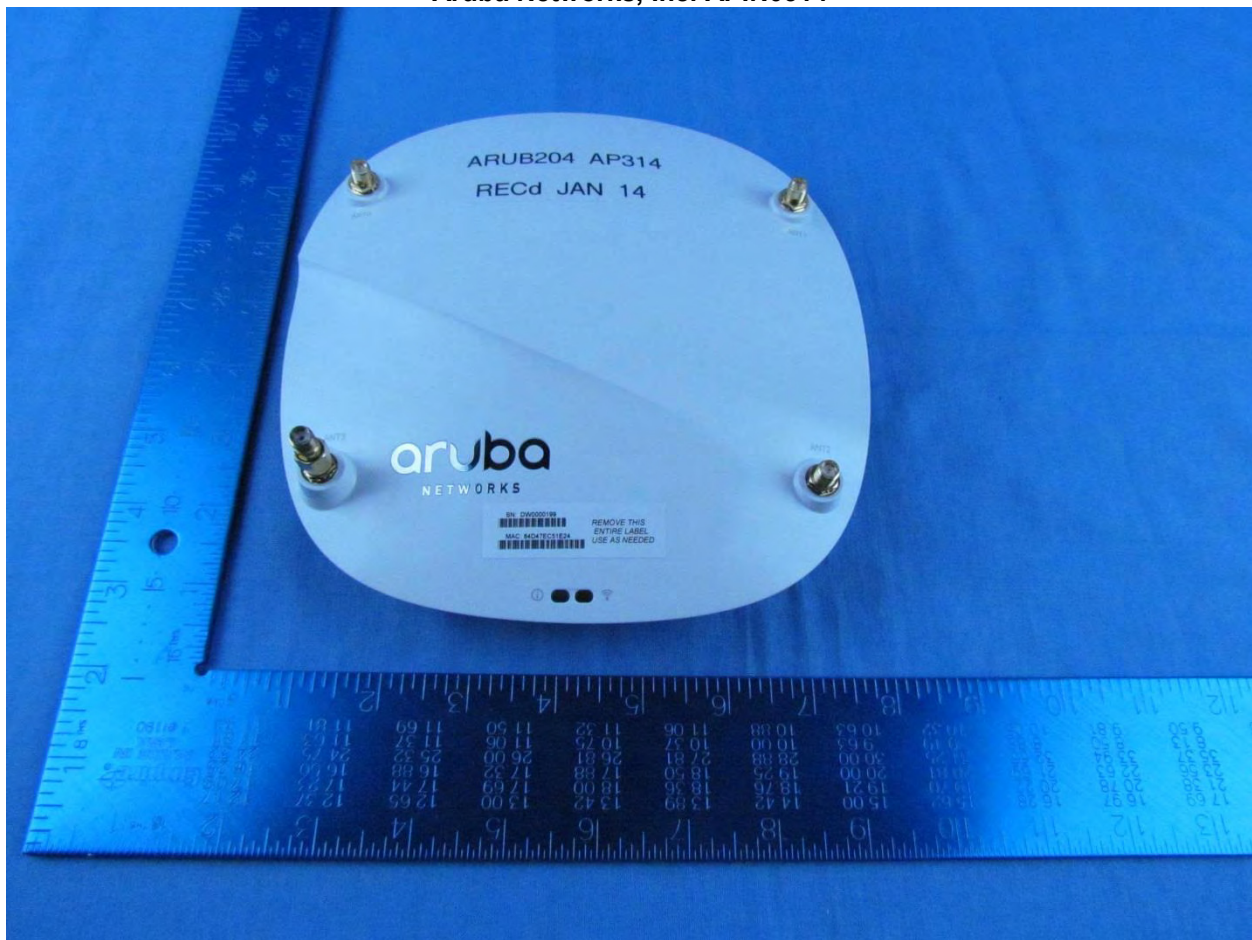

This test report may be reproduced in full only. The document may only be updated by MiCOM Labs personnel. All changes will be noted in the Document History section of the report.

Aruba Networks, Inc. APIN0315

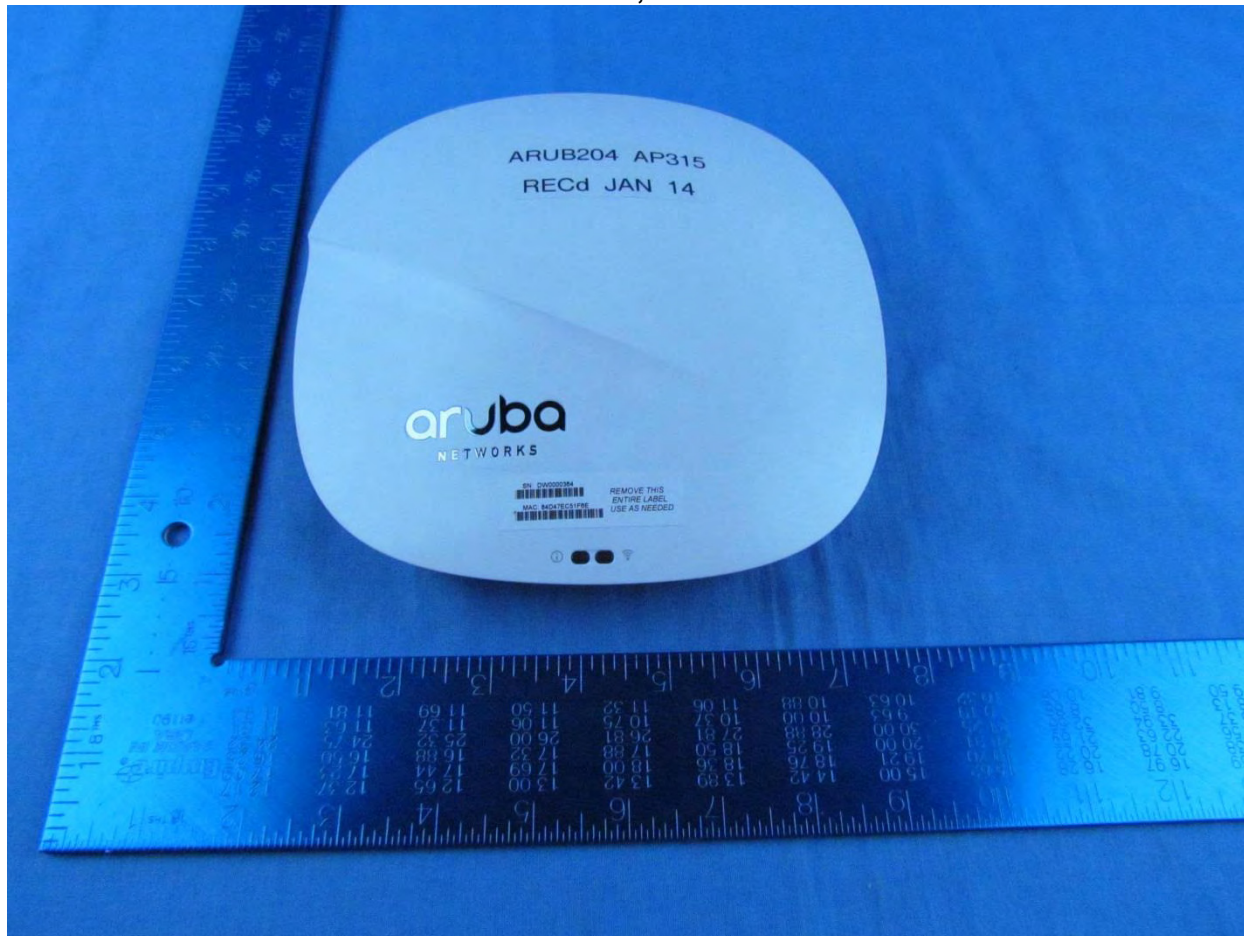

This test report may be reproduced in full only. The document may only be updated by MiCOM Labs personnel. All changes will be noted in the Document History section of the report.



Title: Aruba Networks, Inc. APIN0314 & APIN0315
To: FCC Part 15.247 (DTS) & IC RSS-247
Serial #: ARUB204-U2 Rev A Bluetooth BLE
Issue Date: 4th April 2016
Page: 14 of 62

5.3. Equipment Model(s) and Serial Number(s)

Type	Description	Manufacturer	Model	Serial no.	Delivery Date
EUT	WLAN Access Point - Bluetooth	Aruba Network	APIN0314	DW0000254	16 th February 2016
EUT	WLAN Access Point - Bluetooth	Aruba Network	APIN0315	DW0000541	16 th February 2016

5.4. Antenna Details

Type	Manufacturer	Model	Family	Gain (dBi)	BF Gain	Dir BW	X-Pol	Frequency Band (MHz)
APIN0335	Aruba Networks	Metal Sheet	OMNI	1.5	-	-	-	2400 - 2483.5
APIN0334	Aruba Networks	Metal Sheet	OMNI	3.4	-	-	-	2400 - 2483.5

BF Gain - Beamforming Gain
Dir BW - Directional BeamWidth
X-Pol - Cross Polarization

5.5. Cabling and I/O Ports

Port Type	Max Cable Length	# Of Ports	Screened	Conn Type	Data Type
Ethernet	100m	1	N	RJ-45	Packet Data
RS232	3m	1	N	RJ-45	Digital

5.6. Test Configurations

Results for the following configurations are provided in this report:

Operational Mode(s) (GFSK)	Data Rate with Highest Power MBit/s	Channel Frequency (MHz)		
		Low	Mid	High
2400 - 2483.5 MHz				
GFSK	1.00	2402.00	2442.00	2480.00

This test report may be reproduced in full only. The document may only be updated by MiCOM Labs personnel. All changes will be noted in the Document History section of the report.



Title: Aruba Networks, Inc. APIN0314 & APIN0315
To: FCC Part 15.247 (DTS) & IC RSS-247
Serial #: ARUB204-U2 Rev A Bluetooth BLE
Issue Date: 4th April 2016
Page: 15 of 62

5.7. Equipment Modifications

The following modifications were required to bring the equipment into compliance:

1. NONE

5.8. Deviations from the Test Standard

The following deviations from the test standard were required in order to complete the test program:

1. NONE

This test report may be reproduced in full only. The document may only be updated by MiCOM Labs personnel. All changes will be noted in the Document History section of the report.



Title: Aruba Networks, Inc. APIN0314 & APIN0315
To: FCC Part 15.247 (DTS) & IC RSS-247
Serial #: ARUB204-U2 Rev A Bluetooth BLE
Issue Date: 4th April 2016
Page: 16 of 62

6. TEST SUMMARY

List of Measurements

Test Header	Result	Data Link
Conducted		
15.247(a)(2) 6 dB & 99% Bandwidth	Complies	View Data
15.247(b), 15.31(e) Conducted Output Power	Complies	View Data
15.247(d) Emissions	Complies	-
(1) Conducted Emissions	Complies	-
(i) Conducted Spurious Emissions	Complies	View Data
(ii) Conducted Band-Edge Emissions	Complies	View Data
15.247(e) Power Spectral Density	Complies	View Data
Radiated Emissions		
(i) 15.205 Restricted Band Emissions	Complies	View Data
(ii) 15.205 Restricted Band-Edge Emissions	Complies	View Data
Digital Emissions		
See Report ARUB204-U17 Part 15B & ICES-003		
15.209 Digital Emissions	Complies	
AC Wireline Emissions		
See Report ARUB204-U17 Part 15B & ICES-003		
15.207 AC Wireline Emissions	Complies	

This test report may be reproduced in full only. The document may only be updated by MiCOM Labs personnel. All changes will be noted in the Document History section of the report.

7. TEST EQUIPMENT CONFIGURATION(S)

7.1. Conducted

Conducted RF Emission Test Set-up(s)

The following tests were performed using the conducted test set-up shown in the diagram below.

1. 6 dB & 99% Bandwidth
2. Conducted Output Power
3. Power Spectral Density
4. Conducted Emissions (including Band-Edge)

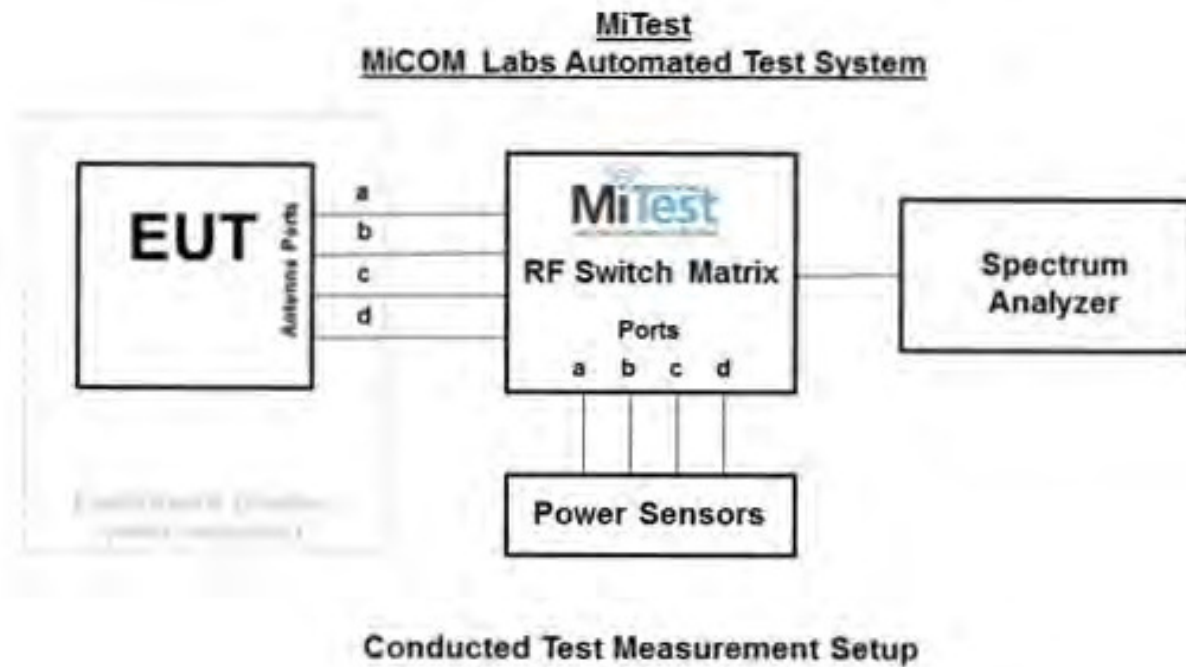

A full system calibration was performed on the test station and any resulting system losses (or gains) were taken into account in the production of all final measurement data.



Title: Aruba Networks, Inc. APIN0314 & APIN0315
To: FCC Part 15.247 (DTS) & IC RSS-247
Serial #: ARUB204-U2 Rev A Bluetooth BLE
Issue Date: 4th April 2016
Page: 18 of 62

Asset#	Description	Manufacturer	Model#	Serial#	Calibration Due Date
158	Barometer/Thermometer	Control Company	4196	E2846	01 Dec 2016
249	Resistance Thermometer	Thermotronics	GR2105-02	9340 #2	23 Oct 2016
287	Rohde & Schwarz 40 GHz Receiver	Rhode & Schwarz	ESIB40	100201	27 Aug 2016
361	Desktop for RF#1, Labview Software installed	Dell	Vostro 220	WS RF#1	Not Required
378	Rohde & Schwarz 40 GHz Receiver with Generator	Rhode & Schwarz	ESIB40	100107/040	04 Aug 2016
380	4x4 RF Switch Box	MiCOM Labs	MiTest RF Switch Box	MIC001	18 Jun 2016
390	USB Power Head 50MHz - 24GHz -60 to +20dBm	Agilent	U2002A	MY50000103	17 Oct 2016
398	Test Software	MiCOM	MiTest ATS	Version 3.0.0.16	Not Required
405	DC Power Supply 0-60V	Agilent	6654A	MY4001826	Cal when used
408	USB to GPIB interface	National Instruments	GPIB-USB HS	14C0DE9	Not Required
436	USB Wideband Power Sensor	Boonton	55006	8731	31 Jul 2016
437	USB Wideband Power Sensor	Boonton	55006	8759	31 Jul 2016
445	PoE Injector	D-Link	DPE-101GL	QTAH1E2000625	Not Required
461	Spectrum Analyzer	Agilent	E4440A	MY46185537	13 Aug 2016
75	Environmental Chamber	Thermatron	SE-300-2-2	27946	24 Nov 2016
RF#1 GPIB#1	GPIB cable to Power Supply	HP	GPIB	None	Not Required
RF#1 SMA SA #452	Precision SMA Male RG-402 Spectrun Analyzer	Fairview Microwave	Precision SMA Male RG 402 coax	None	18 Jun 2016
RF#1 SMA#1	EUT to Mitest box port 1	Flexco	SMA Cable port1	None	18 Jun 2016
RF#1 SMA#2	EUT to Mitest box port 2	Flexco	SMA Cable port2	None	18 Jun 2016
RF#1 SMA#3	EUT to Mitest box port 3	Flexco	SMA Cable port3	None	18 Jun 2016
RF#1 SMA#4	EUT to Mitest box port 4	Flexco	SMA Cable port4	None	18 Jun 2016
RF#1 USB#1	USB Cable to Mitest Box	Dynex	USB Cable	None	Not Required

This test report may be reproduced in full only. The document may only be updated by MiCOM Labs personnel. All changes will be noted in the Document History section of the report.

7.2. Radiated

The following tests were performed using the radiated test set-up shown in the diagram below.

1. Radiated Spurious and Band-Edge Emissions

Radiated Emission Measurement Setup

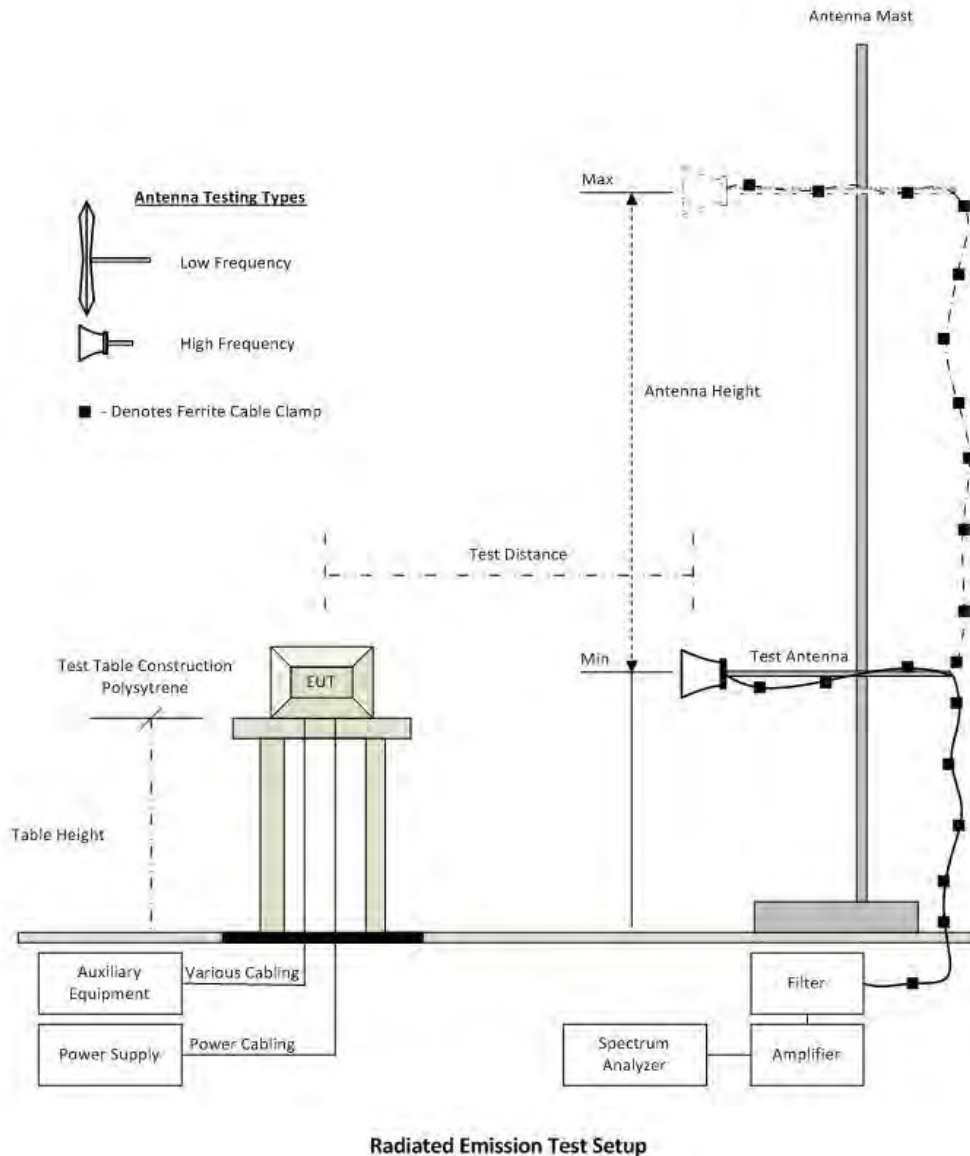

A full system calibration was performed on the test station and any resulting system losses (or gains) were taken into account in the production of all final measurement data.

This test report may be reproduced in full only. The document may only be updated by MiCOM Labs personnel. All changes will be noted in the Document History section of the report.



Title: Aruba Networks, Inc. APIN0314 & APIN0315
To: FCC Part 15.247 (DTS) & IC RSS-247
Serial #: ARUB204-U2 Rev A Bluetooth BLE
Issue Date: 4th April 2016
Page: 20 of 62

Asset#	Description	Manufacturer	Model#	Serial#	Calibration Due Date
158	Barometer/Thermometer	Control Company	4196	E2846	04 Dec 2016
170	Video System Controller for Semi Anechoic Chamber	Panasonic	WV-CY101	04R08507	Not Required
287	Rohde & Schwarz 40 GHz Receiver	Rhode & Schwarz	ESIB40	100201	27 Aug 2016
338	Sunol 30 to 3000 MHz Antenna	Sunol	JB3	A052907	15 Aug 2016
396	2.4 GHz Notch Filter	Microtronics	BRM50701	001	18 Aug 2016
397	Amp 10 - 2500MHz	MiCOM Labs	Amp 10 - 2500 MHz	NA	24 Feb 2016
399	ETS 1-18 GHz Horn Antenna	ETS	3117	00154575	18 th Oct 2016
406	Amplifier for Radiated Emissions	MiCOM Labs	40dB 1 to 18GHz Amp	0406	28 May 2016
410	Desktop Computer	Dell	Inspiron 620	WS38	Not Required
411	Mast/Turntable Controller	Sunol Sciences	SC98V	060199-1D	Not Required
412	USB to GPIB Interface	National Instruments	GPIB-USB HS	11B8DC2	Not Required
413	Mast Controller	Sunol Science	TWR95-4	030801-3	Not Required
415	Turntable Controller	Sunol Sciences	Turntable Controller	None	Not Required
447	Rad Emissions Test Software	MiCOM	Rad Emissions Test Software Version 1.0.73	447	Not Required
462	Schwarzbeck cable from Antenna to Amplifier.	Schwarzbeck	AK 9513	462	25 Feb 2016
463	Schwarzbeck cable from Amplifier to Bulkhead.	Schwarzbeck	AK 9513	463	25 Feb 2016
464	Schwarzbeck cable from Bulkhead to Receiver	Schwarzbeck	AK 9513	464	25 Feb 2016
465	Low Pass Filter DC-1000 MHz	Mini-Circuits	NLP-1200+	VUU01901402	18 Aug 2016
480	Cable - Bulkhead to Amp	SRC Haverhill	157-157-3050360	480	11 Aug 2016
481	Cable - Bulkhead to Receiver	SRC Haverhill	151-151-3050787	481	11 Aug 2016
482	Cable - Amp to Antenna	SRC Haverhill	157-157-3051574	482	11 Aug 2016

This test report may be reproduced in full only. The document may only be updated by MiCOM Labs personnel. All changes will be noted in the Document History section of the report.

8. MEASUREMENT AND PRESENTATION OF TEST DATA

The measurement and graphical data presented in this test report was generated automatically using state-of-the-art technology creating an easy to read report structure. Numerical measurement data is separated from supporting graphical data (plots) through hyperlinks. Numerical measurement data can be reviewed without scrolling through numerous graphical pages to arrive at the next data matrix.

Plots have been relegated into the Appendix 'Graphical Data'.

Test and report automation was performed by [MiTest](#). [MiTest](#) is an automated test system developed by MiCOM Labs. [MiTest](#) is the first cloud based modular test system enabling end-to-end automation of regulatory compliance testing for conducted RF testing.



The MiCOM Labs "[MiTest](#)" Automated Test System" (Patent Pending)

This test report may be reproduced in full only. The document may only be updated by MiCOM Labs personnel. All changes will be noted in the Document History section of the report.



9. TEST RESULTS

9.1. 6 dB & 99% Bandwidth

Conducted Test Conditions for 6 dB and 99% Bandwidth			
Standard:	FCC CFR 47:15.247	Ambient Temp. (°C):	24.0 - 27.5
Test Heading:	6 dB and 99 % Bandwidth	Rel. Humidity (%):	32 - 45
Standard Section(s):	15.247 (a)(2)	Pressure (mBars):	999 - 1001
Reference Document(s):	See Normative References		

Test Procedure for 6 dB and 99% Bandwidth Measurement
The bandwidth at 6 dB and 99 % was measured with a spectrum analyzer connected to the antenna terminal, while EUT is operating in transmission mode at the appropriate center frequency.

Testing was performed under ambient conditions at nominal voltage. Where the device operated with multiple antenna ports i.e. MIMO device, each port was measured and reported.

Test configuration and setup used for the measurement was per the Conducted Test Set-up specified in this document.

Limits for 6 dB and 99% Bandwidth

(a) Operation under the provisions of this Section is limited to frequency hopping and digitally modulated intentional radiators that comply with the following provisions:

(2) Systems using digital modulation techniques may operate in the 902-928 MHz and 2400-2483.5 MHz bands. The minimum 6 dB bandwidth shall be at least 500 kHz.

This test report may be reproduced in full only. The document may only be updated by MiCOM Labs personnel. All changes will be noted in the Document History section of the report.



Title: Aruba Networks, Inc. APIN0314 & APIN0315
To: FCC Part 15.247 (DTS) & IC RSS-247
Serial #: ARUB204-U2 Rev A Bluetooth BLE
Issue Date: 4th April 2016
Page: 23 of 62

Equipment Configuration for 6 dB & 99% Bandwidth

Variant:	BLE	Duty Cycle (%):	99
Data Rate:	1.00 MBit/s	Antenna Gain (dBi):	2
Modulation:	GFSK	Beam Forming Gain (Y)(dB):	Not Applicable
TPC:	Not Applicable	Tested By:	CC
Engineering Test Notes:			

Test Measurement Results

Test Frequency	Measured 6 dB Bandwidth (MHz)				6 dB Bandwidth (MHz)		Limit	Lowest Margin
	Port(s)				Highest	Lowest		
MHz	a	b	c	d			KHz	MHz
2402.0	0.697	--	--	--	0.697	0.697	≥500.0	-0.20
2442.0	0.705	--	--	--	0.705	0.705	≥500.0	-0.20
2480.0	0.705	--	--	--	0.705	0.705	≥500.0	-0.20

Test Frequency	Measured 99% Bandwidth (MHz)				Maximum 99% Bandwidth (MHz)		
	Port(s)						
MHz	a	b	c	d			
2402.0	1.122	--	--	--	1.122		
2442.0	1.098	--	--	--	1.098		
2480.0	1.098	--	--	--	1.098		

Traceability to Industry Recognized Test Methodologies

Work Instruction:	WI-03 MEASURING RF SPECTRUM MASK
Measurement Uncertainty:	±2.81 dB

Note: click the links in the above matrix to view the graphical image (plot).

This test report may be reproduced in full only. The document may only be updated by MiCOM Labs personnel. All changes will be noted in the Document History section of the report.



9.2. Conducted Output Power

Conducted Test Conditions for Fundamental Emission Output Power			
Standard:	FCC CFR 47:15.247	Ambient Temp. (°C):	24.0 - 27.5
Test Heading:	Output Power	Rel. Humidity (%):	32 - 45
Standard Section(s):	15.247 (b) & (c)	Pressure (mBars):	999 - 1001
Reference Document(s):	See Normative References		

Test Procedure for Fundamental Emission Output Power Measurement
In the case of average power measurements an average power sensor was utilized.

For peak power measurements the spectrum analyzer built-in power function was used to integrate peak power over the 20 dB bandwidth.

Testing was performed under ambient conditions at nominal voltage only. Where the device operated with multiple antenna ports i.e. MIMO device, each port was measured, summed (Σ) and reported.

Test configuration and setup used for the measurement was per the Conducted Test Set-up specified in this document.

Supporting Information
Calculated Power = $A + G + Y + 10 \log (1/x)$ dBm

A = Total Power [$10^* \text{Log}_{10} (10^{a/10} + 10^{b/10} + 10^{c/10} + 10^{d/10})$]
 G = Antenna Gain
 Y = Beamforming Gain
 x = Duty Cycle (average power measurements only)

Limits for Fundamental Emission Output Power
(b) The maximum peak conducted output power of the intentional radiator shall not exceed the following for non-frequency hopping systems:

(3) For systems using digital modulation in the 902-928 MHz and 2400-2483.5 MHz bands: 1 Watt. As an alternative to a peak power measurement, compliance with the one Watt limit can be based on a measurement of the maximum conducted output power. Maximum Conducted Output Power is defined as the total transmit power delivered to all antennas and antenna elements averaged across all symbols in the signaling alphabet when the transmitter is operating at its maximum power control level. Power must be summed across all antennas and antenna elements. The average must not include any time intervals during which the transmitter is off or is transmitting at a reduced power level. If multiple modes of operation are possible (e.g., alternative modulation methods), the maximum conducted output power is the highest total transmit power occurring in any mode.

(4) The conducted output power limit specified in paragraph (b) of this section is based on the use of antennas with directional gains that do not exceed 6 dBi. Except as shown in paragraph (c) of this section, if transmitting antennas of directional gain greater than 6 dBi are used, the conducted output power from the intentional radiator shall be reduced below the stated values in paragraphs (b)(3) of this section, as appropriate, by the amount in dB that the directional gain of the antenna exceeds 6 dBi.

(c) Operation with directional antenna gains greater than 6 dBi.

(1) Fixed point-to-point operation:

(i) Systems operating in the 2400-2483.5 MHz band that are used exclusively for fixed, point-to-point operations may employ transmitting antennas with directional gain greater than 6 dBi provided the maximum conducted output power of the intentional radiator is reduced by 1 dB for every 3 dB that the directional gain of the antenna exceeds 6 dBi.

(iii) Fixed, point-to-point operation, as used in paragraphs (c)(1)(i) and (c)(1)(ii) of this section, excludes the use of point-to-multipoint systems, omnidirectional applications, and multiple co-located intentional radiators transmitting the same information. The operator of the spread spectrum or digitally modulated intentional radiator or, if the equipment is professionally installed, the installer is responsible for ensuring that the system is used exclusively for fixed, point-to-point

This test report may be reproduced in full only. The document may only be updated by MiCOM Labs personnel. All changes will be noted in the Document History section of the report.



Title: Aruba Networks, Inc. APIN0314 & APIN0315
To: FCC Part 15.247 (DTS) & IC RSS-247
Serial #: ARUB204-U2 Rev A Bluetooth BLE
Issue Date: 4th April 2016
Page: 25 of 62

operations. The instruction manual furnished with the intentional radiator shall contain language in the installation instructions informing the operator and the installer of this responsibility.

(2) In addition to the provisions in paragraphs (b)(3), (b)(4) and (c)(1)(i) of this section, transmitters operating in the 2400-2483.5 MHz band that emit multiple directional beams, simultaneously or sequentially, for the purpose of directing signals to individual receivers or to groups of receivers provided the emissions comply with the following:

(i) Different information must be transmitted to each receiver.

(ii) If the transmitter employs an antenna system that emits multiple directional beams but does not do emit multiple directional beams simultaneously, the total output power conducted to the array or arrays that comprise the device, i.e., the sum of the power supplied to all antennas, antenna elements, staves, etc. and summed across all carriers or frequency channels, shall not exceed the limit specified in paragraph (b)(1) or (b)(3) of this section, as applicable. However, the total conducted output power shall be reduced by 1 dB below the specified limits for each 3 dB that the directional gain of the antenna/antenna array exceeds 6 dBi. The directional antenna gain shall be computed as follows:

(A) The directional gain shall be calculated as the sum of 10 log (number of array elements or staves) plus the directional gain of the element or stave having the highest gain.

(B) A lower value for the directional gain than that calculated in paragraph (c)(2)(ii)(A) of this section will be accepted if sufficient evidence is presented, e.g., due to shading of the array or coherence loss in the beamforming.

(iii) If a transmitter employs an antenna that operates simultaneously on multiple directional beams using the same or different frequency channels, the power supplied to each emission beam is subject to the power limit specified in paragraph (c)(2)(ii) of this section. If transmitted beams overlap, the power shall be reduced to ensure that their aggregate power does not exceed the limit specified in paragraph (c)(2)(ii) of this section. In addition, the aggregate power transmitted simultaneously on all beams shall not exceed the limit specified in paragraph (c)(2)(ii) of this section by more than 8 dB.

(iv) Transmitters that emit a single directional beam shall operate under the provisions of paragraph (c)(1) of this section.

This test report may be reproduced in full only. The document may only be updated by MiCOM Labs personnel. All changes will be noted in the Document History section of the report.



Title: Aruba Networks, Inc. APIN0314 & APIN0315
To: FCC Part 15.247 (DTS) & IC RSS-247
Serial #: ARUB204-U2 Rev A Bluetooth BLE
Issue Date: 4th April 2016
Page: 26 of 62

Equipment Configuration for Peak Output Power

Variant:	BLE	Duty Cycle (%):	99.0
Data Rate:	1.00 MBit/s	Antenna Gain (dBi):	1.5
Modulation:	GFSK	Beam Forming Gain (Y)(dB):	Not Applicable
TPC:	Not Applicable	Tested By:	CC
Engineering Test Notes:			

Test Measurement Results

Test Frequency	Measured Output Power + DCCF (+0.04 dB) (dBm)				Calculated Total Power Σ Port(s)	Limit	Margin	EUT Power Setting
	Port(s)							
MHz	a	b	c	d	dBm	dBm	dB	
2402.0	4.49	--	--	--	4.49	30.00	-25.51	4.00
2442.0	4.27	--	--	--	4.27	30.00	-25.73	4.00
2480.0	3.87	--	--	--	3.87	30.00	-26.13	4.00

Traceability to Industry Recognized Test Methodologies

Work Instruction:	WI-01 MEASURING RF OUTPUT POWER
Measurement Uncertainty:	± 1.33 dB

DCCF - Duty Cycle Correction Factor

This test report may be reproduced in full only. The document may only be updated by MiCOM Labs personnel. All changes will be noted in the Document History section of the report.



Title: Aruba Networks, Inc. APIN0314 & APIN0315
To: FCC Part 15.247 (DTS) & IC RSS-247
Serial #: ARUB204-U2 Rev A Bluetooth BLE
Issue Date: 4th April 2016
Page: 27 of 62

9.3. Conducted Spurious Emissions

9.3.1. Conducted Spurious Emissions

Conducted Test Conditions for Transmitter Conducted Spurious and Band-Edge Emissions			
Standard:	FCC CFR 47:15.247	Ambient Temp. (°C):	24.0 - 27.5
Test Heading:	Max Unwanted Emission Levels	Rel. Humidity (%):	32 - 45
Standard Section(s):	15.247 (d)	Pressure (mBars):	999 - 1001
Reference Document(s):	See Normative References		
Test Procedure for Transmitter Conducted Spurious and Band-Edge Emissions Measurement Transmitter Conducted Spurious and Band-Edge emissions were measured at a limit of 30 dBc (average detector) or 20 dBc (peak detector) below the highest in-band spectral density measured with a spectrum analyzer connected to the antenna terminal. Measurements were made while EUT was operating in transmit mode of operation at the appropriate centre frequency closest to the band-edge. Emissions were maximized during the measurement and limits derived from the peak spectral power and drawn on each plot. Where the device operated with multiple antenna ports i.e. MIMO device, each port was measured separately. Testing was performed under ambient conditions at nominal voltage only. Test configuration and setup used for the measurement was per the Conducted Test Set-up specified in this document. Limits Transmitter Conducted Spurious and Band-Edge Emissions (d) In any 100 kHz bandwidth outside the frequency band in which the spread spectrum or digitally modulated intentional radiator is operating, the radio frequency power that is produced by the intentional radiator shall be at least 20 dB below that in the 100 kHz bandwidth within the band that contains the highest level of the desired power, based on either an RF conducted or a radiated measurement, provided the transmitter demonstrates compliance with the peak conducted power limits. If the transmitter complies with the conducted power limits based on the use of RMS averaging over a time interval, as permitted under paragraph (b)(3) of this section, the attenuation required under this paragraph shall be 30 dB instead of 20 dB. Attenuation below the general limits specified in §15.209(a) is not required. In addition, radiated emissions which fall in the restricted bands, as defined in §15.205(a), must also comply with the radiated emission limits specified in §15.209(a) (see §15.205(c)).			

This test report may be reproduced in full only. The document may only be updated by MiCOM Labs personnel. All changes will be noted in the Document History section of the report.



Title: Aruba Networks, Inc. APIN0314 & APIN0315
To: FCC Part 15.247 (DTS) & IC RSS-247
Serial #: ARUB204-U2 Rev A Bluetooth BLE
Issue Date: 4th April 2016
Page: 28 of 62

Equipment Configuration for Transmitter Conducted Spurious Emissions

Variant:	BLE	Duty Cycle (%):	99
Data Rate:	1.00 MBit/s	Antenna Gain (dBi):	Not Applicable
Modulation:	GFSK	Beam Forming Gain (Y):	Not Applicable
TPC:	Not Applicable	Tested By:	CC
Engineering Test Notes:			

Test Measurement Results

Test Frequency	Frequency Range	Transmitter Conducted Spurious Emissions (dBm)							
		Port a		Port b		Port c		Port d	
MHz	MHz	SE	Limit	SE	Limit	SE	Limit	SE	Limit
2402.0	30.0 - 26000.0	-32.780	-17.00	--	--	--	--	--	--
2442.0	30.0 - 26000.0	-29.557	-18.00	--	--	--	--	--	--
2480.0	30.0 - 26000.0	-33.880	-19.00	--	--	--	--	--	--

Traceability to Industry Recognized Test Methodologies

Work Instruction:	WI-05 MEASUREMENT OF SPURIOUS EMISSIONS
Measurement Uncertainty:	<=40 GHz ±2.37 dB, > 40 GHz ±4.6 dB

Note: click the links in the above matrix to view the graphical image (plot).

This test report may be reproduced in full only. The document may only be updated by MiCOM Labs personnel. All changes will be noted in the Document History section of the report.



Title: Aruba Networks, Inc. APIN0314 & APIN0315
To: FCC Part 15.247 (DTS) & IC RSS-247
Serial #: ARUB204-U2 Rev A Bluetooth BLE
Issue Date: 4th April 2016
Page: 29 of 62

9.3.2. Conducted Band-Edge Emissions

Low Band-Edge Emissions

Equipment Configuration for Conducted Low Band-Edge Emissions - Peak

Variant:	BLE	Duty Cycle (%):	99.0
Data Rate:	1.00 MBit/s	Antenna Gain (dBi):	1.50
Modulation:	GFSK	Beam Forming Gain (Y)(dB):	Not Applicable
TPC:	Not Applicable	Tested By:	CC
Engineering Test Notes:			

Test Measurement Results

Channel Frequency:	2402.0 MHz					
Band-Edge Frequency:	2400.0 MHz					
Test Frequency Range:	2350.0 - 2406.0 MHz					
Port(s)	Band-Edge Markers and Limit			Revised Limit		Margin
	M1 Amplitude (dBm)	Plot Limit (dBm)	M2 Frequency (MHz)	Amplitude (dBm)	M2A Frequency (MHz)	(MHz)
a	-29.40	-16.00	2401.30	--	--	-1.300

Traceability to Industry Recognized Test Methodologies

Work Instruction:	WI-05 MEASUREMENT OF SPURIOUS EMISSIONS
Measurement Uncertainty:	<=40 GHz \pm 2.37 dB, > 40 GHz \pm 4.6 dB

Note: click the links in the above matrix to view the graphical image (plot).

This test report may be reproduced in full only. The document may only be updated by MiCOM Labs personnel. All changes will be noted in the Document History section of the report.



Title: Aruba Networks, Inc. APIN0314 & APIN0315
To: FCC Part 15.247 (DTS) & IC RSS-247
Serial #: ARUB204-U2 Rev A Bluetooth BLE
Issue Date: 4th April 2016
Page: 30 of 62

High Band-Edge Emissions

Equipment Configuration for Conducted High Band-Edge Emissions - Peak

Variant:	BLE	Duty Cycle (%):	99.0
Data Rate:	1.00 MBit/s	Antenna Gain (dBi):	1.50
Modulation:	GFSK	Beam Forming Gain (Y)(dB):	Not Applicable
TPC:	Not Applicable	Tested By:	CC
Engineering Test Notes:			

Test Measurement Results

Channel Frequency:	2480.0 MHz					
Band-Edge Frequency:	2483.5 MHz					
Test Frequency Range:	2478.0 - 2524.0 MHz					
Port(s)	Band-Edge Markers and Limit			Revised Limit		Margin
	M3 Amplitude (dBm)	Plot Limit (dBm)	M2 Frequency (MHz)	Amplitude (dBm)	M2A Frequency (MHz)	(MHz)
a	-45.54	-17.00	2480.60	--	--	-2.900

Traceability to Industry Recognized Test Methodologies

Work Instruction:	WI-05 MEASUREMENT OF SPURIOUS EMISSIONS
Measurement Uncertainty:	<=40 GHz ±2.37 dB, > 40 GHz ±4.6 dB

Note: click the links in the above matrix to view the graphical image (plot).

This test report may be reproduced in full only. The document may only be updated by MiCOM Labs personnel. All changes will be noted in the Document History section of the report.



9.4. Power Spectral Density

Conducted Test Conditions for Power Spectral Density			
Standard:	FCC CFR 47:15.247	Ambient Temp. (°C):	24.0 - 27.5
Test Heading:	Power Spectral Density	Rel. Humidity (%):	32 - 45
Standard Section(s):	15.247 (e)	Pressure (mBars):	999 - 1001
Reference Document(s):	See Normative References		

Test Procedure for Power Spectral Density

The transmitter output was connected to a spectrum analyzer and the measured made in a 3 kHz resolution bandwidth using the analyzer auto-coupled sweep-time. A peak value was found over the full emission bandwidth and the spectrum downloaded for post processing purposes.

Where the device operated with multiple antenna ports i.e. MIMO device, each port was measured separately. The Peak Power Spectral Density is the highest level found across the emission bandwidth. With multiple antenna port measurements the numerical analyzer data from each port is summed (\hat{a}) and a link to this additional graphic is provided.

Testing was performed under ambient conditions at nominal voltage only.

Test configuration and setup used for the measurement was per the Conducted Test Set-up specified in this document.

Measure and sum the spectra across the outputs. With this technique, spectra are measured at each output of the device at the required resolution bandwidth. The individual spectra are then summed mathematically in linear power units. Unlike in-band power measurements, in which the sum involves a single measured value (output power) from each output, measurements for compliance with PSD limits involve summing entire spectra across corresponding frequency bins on the various outputs. Consistency is maintained for any device with multiple transmitter outputs to be certain the individual outputs are all aligned with the same span and same number of points. In this instance, the linear power spectrum value within the first spectral bin of output 0 is summed with that in the first spectral bin of output 1, and the first spectral bin of output 2, and so on up to the Nth output to obtain the true value for the first frequency bin of the summed spectrum. The summed spectrum value for each frequency bin is computed in this fashion. These summed spectral values were post processed and the resulting numerical and graphical data presented.

NOTE:

It may be observed that the spectrum in some antenna port plots break the limit line however this in itself does NOT constitute a failure. In all cases a spectrum summation plot is provided in order to prove compliance. A failure occurs only after the summation of all spectrum plots have been summed and are found to be greater than the limit line.

Supporting Information

Calculated Power = $A + 10 \log(1/x)$ dBm

A = Total Power Spectral Density [$10 \log_{10}(10^{a/10} + 10^{b/10} + 10^{c/10} + 10^{d/10})$]

x = Duty Cycle

Limits Power Spectral Density

For digitally modulated systems, the power spectral density conducted from the intentional radiator to the antenna shall not be greater than +8 dBm in any 3 kHz band during any time interval of continuous transmission. This power spectral density shall be determined in accordance with the provisions of paragraph (b) of this section. The same method of determining the conducted output power shall be used to determine the power spectral density.



Title: Aruba Networks, Inc. APIN0314 & APIN0315
To: FCC Part 15.247 (DTS) & IC RSS-247
Serial #: ARUB204-U2 Rev A Bluetooth BLE
Issue Date: 4th April 2016
Page: 32 of 62

Equipment Configuration for Power Spectral Density - Peak

Variant:	BLE	Duty Cycle (%):	99.0
Data Rate:	1.00 MBit/s	Antenna Gain (dBi):	1.50
Modulation:	GFSK	Beam Forming Gain (Y)(dB):	Not Applicable
TPC:	Not Applicable	Tested By:	CC
Engineering Test Notes:			

Test Measurement Results

Test Frequency	Measured Power Spectral Density				Amplitude Summation	Limit	Margin
	Port(s) (dBm/3KHz)						
MHz	a	b	c	d	dBm/3KHz	dBm/3KHz	dB
2402.0	-8.760	--	--	--	Not Applicable	8.0	-16.8
2442.0	-9.486	--	--	--	Not Applicable	8.0	-17.5
2480.0	-10.363	--	--	--	Not Applicable	8.0	-18.4

Traceability to Industry Recognized Test Methodologies

Work Instruction:	WI-03 MEASURING RF SPECTRUM MASK
Measurement Uncertainty:	±2.81 dB

Note: click the links in the above matrix to view the graphical image (plot).

This test report may be reproduced in full only. The document may only be updated by MiCOM Labs personnel. All changes will be noted in the Document History section of the report.



9.5. Radiated Emissions

Radiated Test Conditions for Radiated Spurious and Band-Edge Emissions (Restricted Bands)			
Standard:	FCC CFR 47 Part 15 Subpart C 15.247 (DTS)	Ambient Temp. (°C):	20.0 - 24.5
Test Heading:	Radiated Spurious and Band-Edge Emissions	Rel. Humidity (%):	32 - 45
Standard Section(s):	15.205, 15.209	Pressure (mBars):	999 - 1001
Reference Document(s):	See Normative References		

Test Procedure for Radiated Spurious and Band-Edge Emissions (Restricted Bands)

Radiated emissions for restricted bands above 1 GHz are measured in the anechoic chamber at a 3-meter distance on every azimuth in both horizontal and vertical polarities. The emissions are recorded and maximized as a function of azimuth by rotation through 360° with a spectrum analyzer in peak hold mode. Depending on the frequency band spanned a notch filter and waveguide filter was used to remove the fundamental frequency. The highest emissions relative to the limit are listed for each frequency spanned. Measurements on any restricted band frequency or frequencies above 1 GHz are based on the use of measurement instrumentation employing peak and average detectors. All measurements were performed using a resolution bandwidth of 1 MHz.

Test configuration and setup for Radiated Spurious and Band-Edge Measurement were per the Radiated Test Set-up specified in this document.

Limits for Restricted Bands

Peak emission: 74 dBuV/m

Average emission: 54 dBuV/m

Field Strength Calculation

The field strength is calculated by adding the Antenna Factor and Cable Loss, and subtracting Amplifier Gain from the measured reading. All factors are included in the reported data.

$$FS = R + AF + CORR - FO$$

where:

FS = Field Strength

R = Measured Spectrum analyzer Input Amplitude

AF = Antenna Factor

CORR = Correction Factor = CL – AG + NFL

CL = Cable Loss

AG = Amplifier Gain

FO = Distance Falloff Factor

NFL = Notch Filter Loss or Waveguide Loss

Example:

Given receiver input reading of 51.5 dBmV; Antenna Factor of 8.5 dB; Cable Loss of 1.3 dB; Falloff Factor of 0 dB, an Amplifier Gain of 26 dB and Notch Filter Loss of 1 dB. The Field Strength (FS) of the measured emission is:

$$FS = 51.5 + 8.5 + 1.3 - 26.0 + 1 = 36.3 \text{ dBmV/m}$$

Conversion between dBmV/m (or dBmV) and mV/m (or mV) are as follows:

$$\text{Level (dBmV/m)} = 20 * \text{Log (level (mV/m))}$$

$$40 \text{ dBmV/m} = 100 \text{ mV/m}$$

$$48 \text{ dBmV/m} = 250 \text{ mV/m}$$

Restricted Bands of Operation (15.205)

(a) Except as shown in paragraph (d) of this section, only spurious emissions are permitted in any of the frequency bands listed below:



Title: Aruba Networks, Inc. APIN0314 & APIN0315
To: FCC Part 15.247 (DTS) & IC RSS-247
Serial #: ARUB204-U2 Rev A Bluetooth BLE
Issue Date: 4th April 2016
Page: 34 of 62

Frequency Band			
MHz	MHz	MHz	GHz
0.090-0.110	16.42-16.423	399.9-410	4.5-5.15
0.495-0.505	16.69475-16.69525	608-614	5.35-5.46
2.1735-2.1905	16.80425-16.80475	960-1240	7.25-7.75
4.125-4.128	25.5-25.67	1300-1427	8.025-8.5
4.17725-4.17775	37.5-38.25	1435-1626.5	9.0-9.2
4.20725-4.20775	73-74.6	1645.5-1646.5	9.3-9.5
6.215-6.218	74.8-75.2	1660-1710	10.6-12.7
6.26775-6.26825	108-121.94	1718.8-1722.2	13.25-13.4
6.31175-6.31225	123-138	2200-2300	14.47-14.5
8.291-8.294	149.9-150.05	2310-2390	15.35-16.2
8.362-8.366	156.52475-156.52525	2483.5-2500	17.7-21.4
8.37625-8.38675	156.7-156.9	2690-2900	22.01-23.12
8.41425-8.41475	162.0125-167.17	3260-3267	23.6-24.0
12.29-12.293	167.72-173.2	3332-3339	31.2-31.8
12.51975-12.52025	240-285	3345.8-3358	36.43-36.5
12.57675-12.57725	322-335.4	3600-4400	Above 38.6
13.36-13.41			

(b) Except as provided in paragraphs (d) and (e) of this section, the field strength of emissions appearing within these frequency bands shall not exceed the limits shown in §15.209. At frequencies equal to or less than 1000 MHz, compliance with the limits in §15.209 shall be demonstrated using measurement instrumentation employing a CISPR quasi-peak detector. Above 1000 MHz, compliance with the emission limits in §15.209 shall be demonstrated based on the average value of the measured emissions. The provisions in §15.35 apply to these measurements.

(c) Except as provided in paragraphs (d) and (e) of this section, regardless of the field strength limits specified elsewhere in this subpart, the provisions of this section apply to emissions from any intentional radiator.

(d) The following devices are exempt from the requirements of this section:

- (1) Swept frequency field disturbance sensors operating between 1.705 and 37 MHz provided their emissions only sweep through the bands listed in paragraph (a) of this section, the sweep is never stopped with the fundamental emission within the bands listed in paragraph (a) of this section, and the fundamental emission is outside of the bands listed in paragraph (a) of this section more than 99% of the time the device is actively transmitting, without compensation for duty cycle.
- (2) Transmitters used to detect buried electronic markers at 101.4 kHz which are employed by telephone companies.
- (3) Cable locating equipment operated pursuant to §15.213.
- (4) Any equipment operated under the provisions of §15.253, 15.255, and 15.256 in the frequency band 75-85 GHz, or §15.257 of this part.
- (5) Biomedical telemetry devices operating under the provisions of §15.242 of this part are not subject to the restricted band 608-614 MHz but are subject to compliance within the other restricted bands.
- (6) Transmitters operating under the provisions of subparts D or F of this part.
- (7) Devices operated pursuant to §15.225 are exempt from complying with this section for the 13.36-13.41 MHz band only.

This test report may be reproduced in full only. The document may only be updated by MiCOM Labs personnel. All changes will be noted in the Document History section of the report.



Title: Aruba Networks, Inc. APIN0314 & APIN0315
To: FCC Part 15.247 (DTS) & IC RSS-247
Serial #: ARUB204-U2 Rev A Bluetooth BLE
Issue Date: 4th April 2016
Page: 35 of 62

(8) Devices operated in the 24.075-24.175 GHz band under §15.245 are exempt from complying with the requirements of this section for the 48.15-48.35 GHz and 72.225-72.525 GHz bands only, and shall not exceed the limits specified in §15.245(b).

(9) Devices operated in the 24.0-24.25 GHz band under §15.249 are exempt from complying with the requirements of this section for the 48.0-48.5 GHz and 72.0-72.75 GHz bands only, and shall not exceed the limits specified in §15.249(a).

(e) Harmonic emissions appearing in the restricted bands above 17.7 GHz from field disturbance sensors operating under the provisions of §15.245 shall not exceed the limits specified in §15.245(b).

This test report may be reproduced in full only. The document may only be updated by MiCOM Labs personnel. All changes will be noted in the Document History section of the report.



Title: Aruba Networks, Inc. APIN0314 & APIN0315
To: FCC Part 15.247 (DTS) & IC RSS-247
Serial #: ARUB204-U2 Rev A Bluetooth BLE
Issue Date: 4th April 2016
Page: 36 of 62

9.5.1. Restricted Band Emissions

Equipment Configuration for Radiated Spurious - Restricted Band Emissions

Antenna:	APIN0335 Antenna	Variant:	BLE
Antenna Gain (dBi):	1.50	Modulation:	CCK
Beam Forming Gain (Y):	Not Applicable	Duty Cycle (%):	100
Channel Frequency (MHz):	2402.00	Data Rate:	1.00 MBit/s
Power Setting:	4	Tested By:	JMH

Test Measurement Results

Num	Frequency MHz	Raw dB μ V	Cable Loss	AF dB	Level dB μ V/m	Measurement Type	Pol	Hgt cm	Azt Deg	Limit dB μ V/m	Margin dB	Pass /Fail
#1	1792.63	55.86	2.46	-13.78	44.54	Peak (NRB)	Vertical	150	117	--	--	Pass
#2	4806.03	49.45	3.50	-11.12	41.83	Max Avg	Horizontal	146	278	54.0	-12.2	Pass
#3	4806.03	55.90	3.50	-11.12	48.28	Max Peak	Horizontal	146	278	74.0	-25.7	Pass

Test Notes: EUT on 150cm table powered by laptop. Connected to laptop inside chamber

This test report may be reproduced in full only. The document may only be updated by MiCOM Labs personnel. All changes will be noted in the Document History section of the report.



Title: Aruba Networks, Inc. APIN0314 & APIN0315
To: FCC Part 15.247 (DTS) & IC RSS-247
Serial #: ARUB204-U2 Rev A Bluetooth BLE
Issue Date: 4th April 2016
Page: 37 of 62

Equipment Configuration for Radiated Spurious - Restricted Band Emissions

Antenna:	APIN0335 Antenna	Variant:	BLE
Antenna Gain (dBi):	1.50	Modulation:	CCK
Beam Forming Gain (Y):	Not Applicable	Duty Cycle (%):	100
Channel Frequency (MHz):	2440.00	Data Rate:	1.00 MBit/s
Power Setting:	4	Tested By:	JMH

Test Measurement Results

Num	Frequency MHz	Raw dBµV	Cable Loss	AF dB	Level dBµV/m	Measurement Type	Pol	Hgt cm	Azt Deg	Limit dBµV/m	Margin dB	Pass /Fail
#1	1792.99	53.77	2.46	-13.78	42.45	Peak (NRB)	Horizontal	151	360	--	--	Pass
#2	1792.99	53.77	2.46	-13.78	42.45	Peak (NRB)	Horizontal	151	360	--	--	Pass

Test Notes: EUT on 150cm table powered by laptop. Connected to laptop inside chamber

This test report may be reproduced in full only. The document may only be updated by MiCOM Labs personnel. All changes will be noted in the Document History section of the report.



Title: Aruba Networks, Inc. APIN0314 & APIN0315
To: FCC Part 15.247 (DTS) & IC RSS-247
Serial #: ARUB204-U2 Rev A Bluetooth BLE
Issue Date: 4th April 2016
Page: 38 of 62

Equipment Configuration for Radiated Spurious - Restricted Band Emissions
--

Antenna:	APIN0335 Antenna	Variant:	BLE
Antenna Gain (dBi):	1.50	Modulation:	GFSK
Beam Forming Gain (Y):	Not Applicable	Duty Cycle (%):	100
Channel Frequency (MHz):	2480.00	Data Rate:	1.00 MBit/s
Power Setting:	4	Tested By:	JMH

Test Measurement Results

Click here to view measurement data...
--

Test Notes: EUT on 150cm table powered by laptop. Connected to laptop inside chamber
--

This test report may be reproduced in full only. The document may only be updated by MiCOM Labs personnel. All changes will be noted in the Document History section of the report.



Title: Aruba Networks, Inc. APIN0314 & APIN0315
To: FCC Part 15.247 (DTS) & IC RSS-247
Serial #: ARUB204-U2 Rev A Bluetooth BLE
Issue Date: 4th April 2016
Page: 39 of 62

9.5.2. Restricted Band-Edge Emissions

Equipment Configuration for Radiated - Lower Restricted Band-Edge Emissions

Antenna:	APIN0335 Antenna	Variant:	BLE
Antenna Gain (dBi):	1.50	Modulation:	GFSK
Beam Forming Gain (Y):	Not Applicable	Duty Cycle (%):	
Channel Frequency (MHz):	2402.00	Data Rate:	1.00 MBit/s
Power Setting:	4	Tested By:	JMH

Test Measurement Results

Num	Frequency MHz	Raw dB μ V	Cable Loss	AF dB	Level dB μ V/m	Measurement Type	Pol	Hgt cm	Azt Deg	Limit dB μ V/m	Margin dB	Pass /Fail
#1	2390.00	3.66	2.69	32.04	38.39	Max Avg	Horizontal	117	41	54.0	-15.6	Pass
#2	2390.00	15.12	2.69	32.04	49.85	Max Peak	Horizontal	117	41	74.0	-24.2	Pass
#3	2390.00	--	--	--	--	Band Edge	--	--	--	--	--	--

Test Notes: EUT on 150cm table powered by cc debugger connected to laptop

This test report may be reproduced in full only. The document may only be updated by MiCOM Labs personnel. All changes will be noted in the Document History section of the report.



Title: Aruba Networks, Inc. APIN0314 & APIN0315
To: FCC Part 15.247 (DTS) & IC RSS-247
Serial #: ARUB204-U2 Rev A Bluetooth BLE
Issue Date: 4th April 2016
Page: 40 of 62

Equipment Configuration for Radiated - Upper Restricted Band-Edge Emissions

Antenna:	APIN0335 Antenna	Variant:	BLE
Antenna Gain (dBi):	1.50	Modulation:	GFSK
Beam Forming Gain (Y):	Not Applicable	Duty Cycle (%):	
Channel Frequency (MHz):	2480.00	Data Rate:	1.00 MBit/s
Power Setting:	4	Tested By:	JMH

Test Measurement Results

Num	Frequency MHz	Raw dBµV	Cable Loss	AF dB	Level dBµV/m	Measurement Type	Pol	Hgt cm	Azt Deg	Limit dBµV/m	Margin dB	Pass /Fail
#1	2483.50	17.03	2.73	32.37	52.13	Max Avg	Horizontal	151	46	54.0	-1.9	Pass
#2	2483.50	27.49	2.73	32.37	62.59	Max Peak	Horizontal	151	46	74.0	-11.4	Pass
#3	2483.50	--	--	--	--	Band Edge	--	--	--	--	--	--

Test Notes: EUT on 150cm table powered by cc debugger connected to laptop

This test report may be reproduced in full only. The document may only be updated by MiCOM Labs personnel. All changes will be noted in the Document History section of the report.



Title: Aruba Networks, Inc. APIN0314 & APIN0315
To: FCC Part 15.247 (DTS) & IC RSS-247
Serial #: ARUB204-U2 Rev A Bluetooth BLE
Issue Date: 4th April 2016
Page: 41 of 62

APPENDIX A - GRAPHICAL IMAGES

This test report may be reproduced in full only. The document may only be updated by MiCOM Labs personnel. All changes will be noted in the Document History section of the report.



A.1. 6 dB & 99% Bandwidth

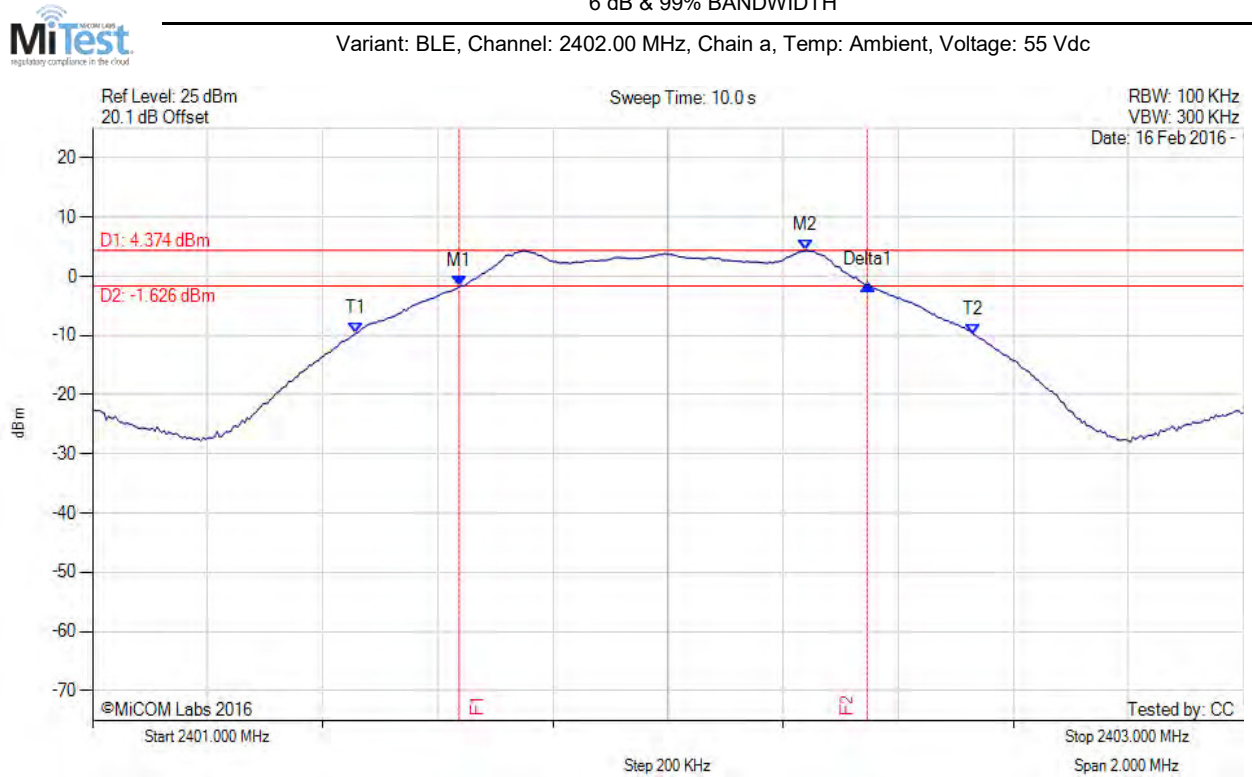

Analyzer Setup	Marker:Frequency:Amplitude	Test Results
Detector = MAX PEAK Sweep Count = 0 RF Atten (dB) = 20 Trace Mode = MAX HOLD	M1 : 2401.637 MHz : -1.754 dBm M2 : 2402.238 MHz : 4.374 dBm Delta1 : 709 KHz : 0.281 dB T1 : 2401.457 MHz : -9.647 dBm T2 : 2402.531 MHz : -9.830 dBm OBW : 1.074 MHz	Measured 6 dB Bandwidth: 0.709 MHz Limit: ≥500.0 kHz Margin: -0.21 MHz

[back to matrix](#)

This test report may be reproduced in full only. The document may only be updated by MiCOM Labs personnel. All changes will be noted in the Document History section of the report.



6 dB & 99% BANDWIDTH



Variant: BLE, Channel: 2402.00 MHz, Chain a, Temp: Ambient, Voltage: 55 Vdc

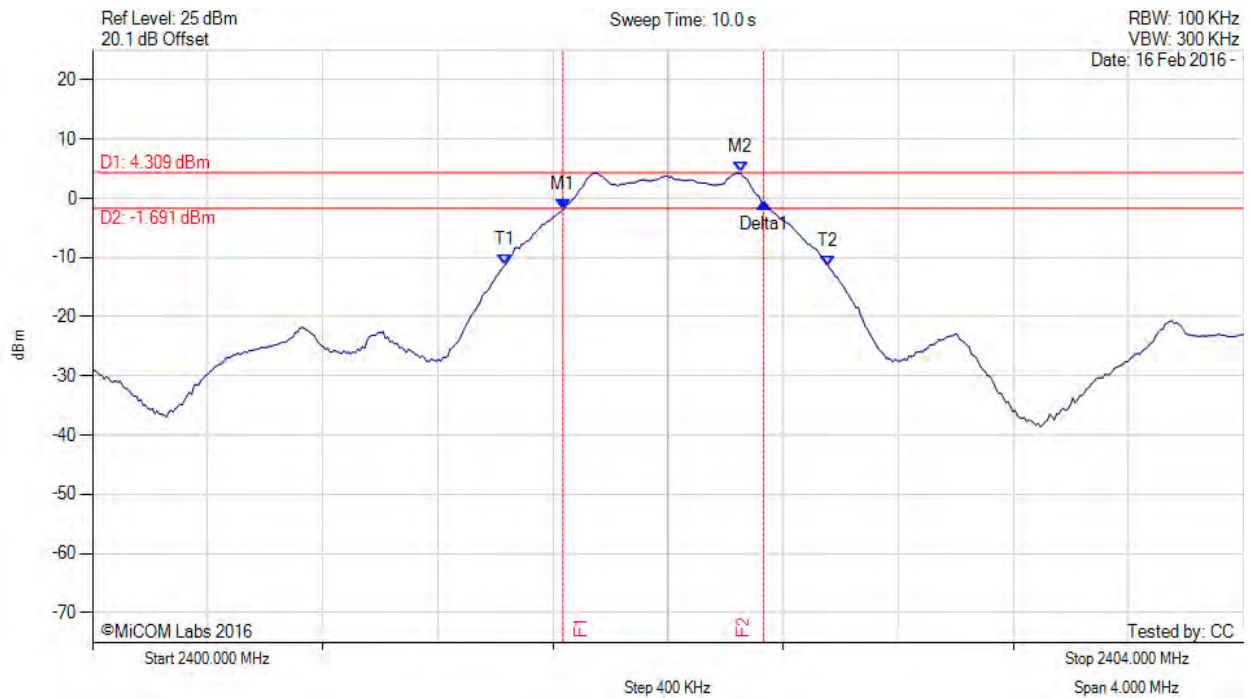

Analyzer Setup	Marker:Frequency:Amplitude	Test Results
Detector = MAX PEAK Sweep Count = 0 RF Atten (dB) = 20 Trace Mode = MAX HOLD	M1 : 2401.635 MHz : -1.850 dBm M2 : 2402.253 MHz : 4.309 dBm Delta1 : 697 KHz : 1.035 dB T1 : 2401.435 MHz : -11.219 dBm T2 : 2402.557 MHz : -11.437 dBm OBW : 1.122 MHz	Measured 6 dB Bandwidth: 0.697 MHz Limit: ≥500.0 kHz Margin: -0.20 MHz

[back to matrix](#)

This test report may be reproduced in full only. The document may only be updated by MiCOM Labs personnel. All changes will be noted in the Document History section of the report.



Title: Aruba Networks, Inc. APIN0314 & APIN0315
To: FCC Part 15.247 (DTS) & IC RSS-247
Serial #: ARUB204-U2 Rev A Bluetooth BLE
Issue Date: 4th April 2016
Page: 44 of 62

6 dB & 99% BANDWIDTH



Variant: BLE, Channel: 2442.00 MHz, Chain a, Temp: Ambient, Voltage: 55 Vdc

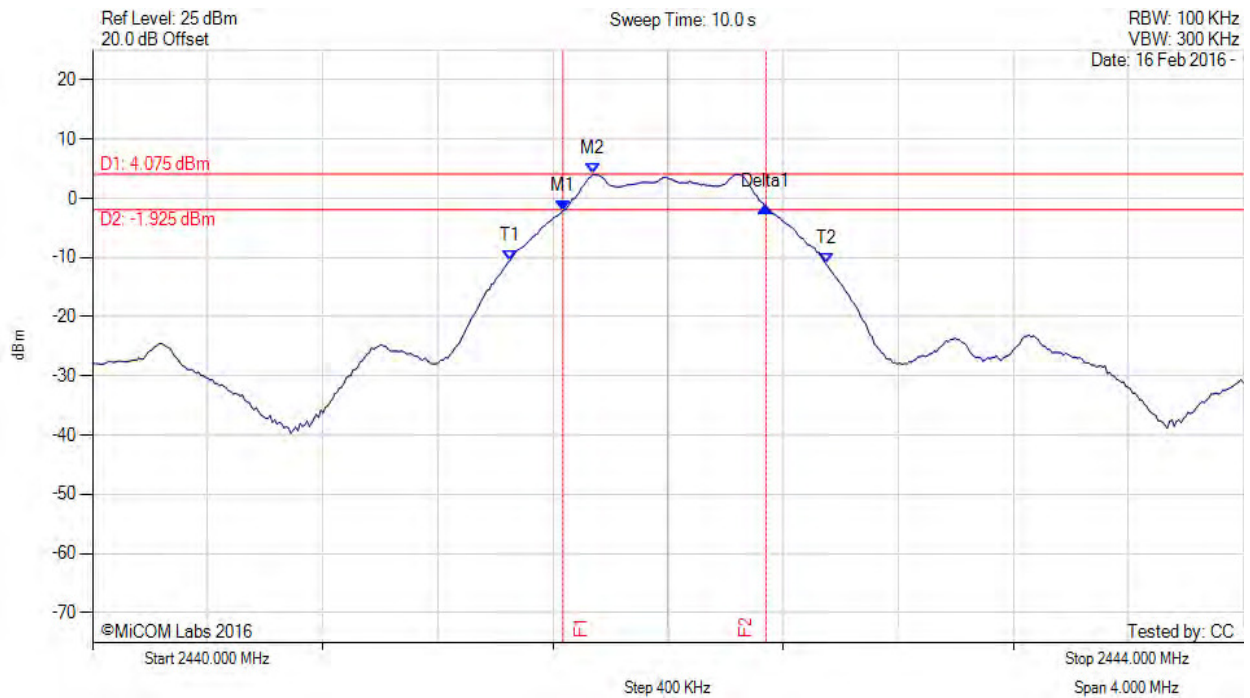

Analyzer Setup	Marker:Frequency:Amplitude	Test Results
Detector = MAX PEAK Sweep Count = 0 RF Atten (dB) = 20 Trace Mode = MAX HOLD	M1 : 2441.635 MHz : -2.059 dBm M2 : 2441.739 MHz : 4.075 dBm Delta1 : 705 KHz : 0.700 dB T1 : 2441.451 MHz : -10.530 dBm T2 : 2442.549 MHz : -11.101 dBm OBW : 1.098 MHz	Measured 6 dB Bandwidth: 0.705 MHz Limit: ≥500.0 kHz Margin: -0.20 MHz

[back to matrix](#)

This test report may be reproduced in full only. The document may only be updated by MiCOM Labs personnel. All changes will be noted in the Document History section of the report.



Title: Aruba Networks, Inc. APIN0314 & APIN0315
To: FCC Part 15.247 (DTS) & IC RSS-247
Serial #: ARUB204-U2 Rev A Bluetooth BLE
Issue Date: 4th April 2016
Page: 45 of 62

6 dB & 99% BANDWIDTH



Variant: BLE, Channel: 2480.00 MHz, Chain a, Temp: Ambient, Voltage: 55 Vdc

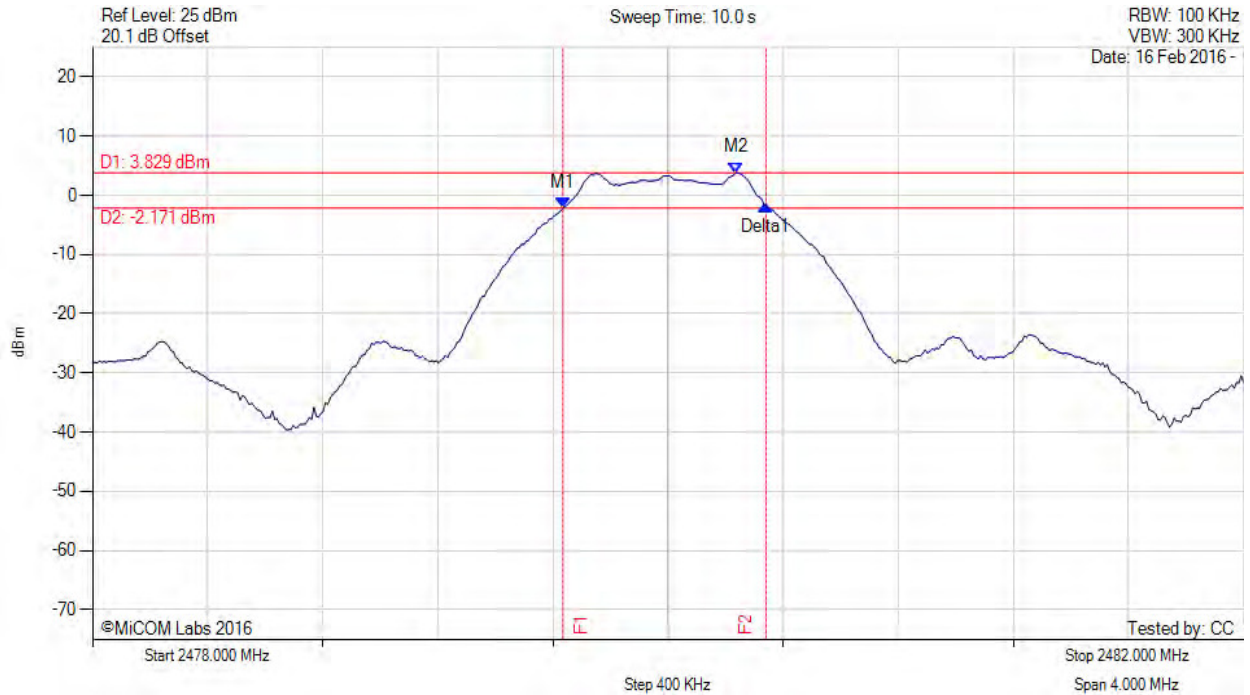

Analyzer Setup	Marker:Frequency:Amplitude	Test Results
Detector = MAX PEAK Sweep Count = 0 RF Atten (dB) = 20 Trace Mode = MAX HOLD	M1 : 2479.635 MHz : -2.216 dBm M2 : 2480.236 MHz : 3.829 dBm Delta1 : 705 KHz : 0.547 dB T1 : 0 Hz : 500.000 dBm T2 : 0 Hz : 500.000 dBm OBW : 1.098 MHz	Measured 6 dB Bandwidth: 0.705 MHz Limit: ≥ 500.0 kHz Margin: -0.20 MHz

[back to matrix](#)

This test report may be reproduced in full only. The document may only be updated by MiCOM Labs personnel. All changes will be noted in the Document History section of the report.



A.2. Conducted Output Power

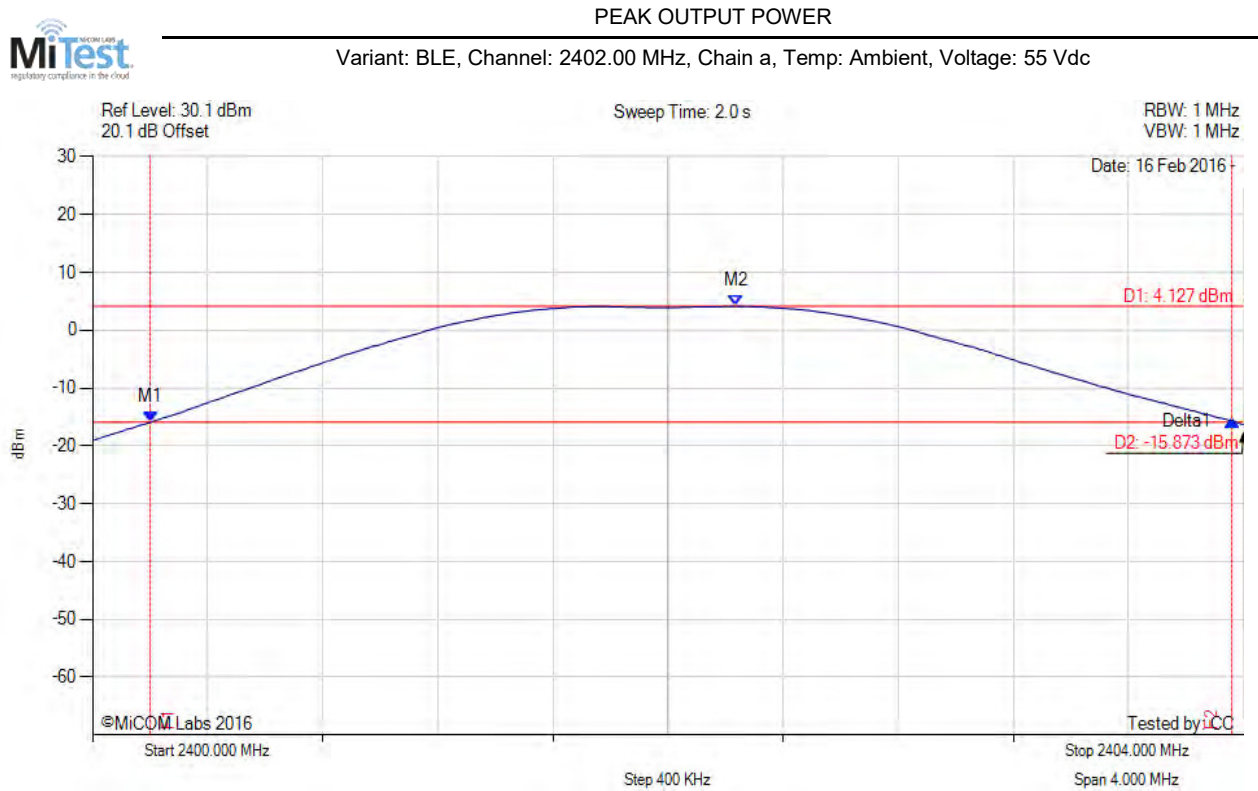

Analyzer Setup	Marker:Frequency:Amplitude	Test Results
Detector = MAX PEAK Sweep Count = 0 RF Atten (dB) = 20 Trace Mode = VIEW	M1 : 2400.200 MHz : -15.968 dBm M2 : 2402.236 MHz : 4.127 dBm Delta1 : 3.760 MHz : 0.309 dB	Channel Power: 4.49 dBm Limit: 30.00 dBm Margin: dB

[back to matrix](#)

This test report may be reproduced in full only. The document may only be updated by MiCOM Labs personnel. All changes will be noted in the Document History section of the report.



Title: Aruba Networks, Inc. APIN0314 & APIN0315
To: FCC Part 15.247 (DTS) & IC RSS-247
Serial #: ARUB204-U2 Rev A Bluetooth BLE
Issue Date: 4th April 2016
Page: 47 of 62

PEAK OUTPUT POWER



Variant: BLE, Channel: 2442.00 MHz, Chain a, Temp: Ambient, Voltage: 55 Vdc

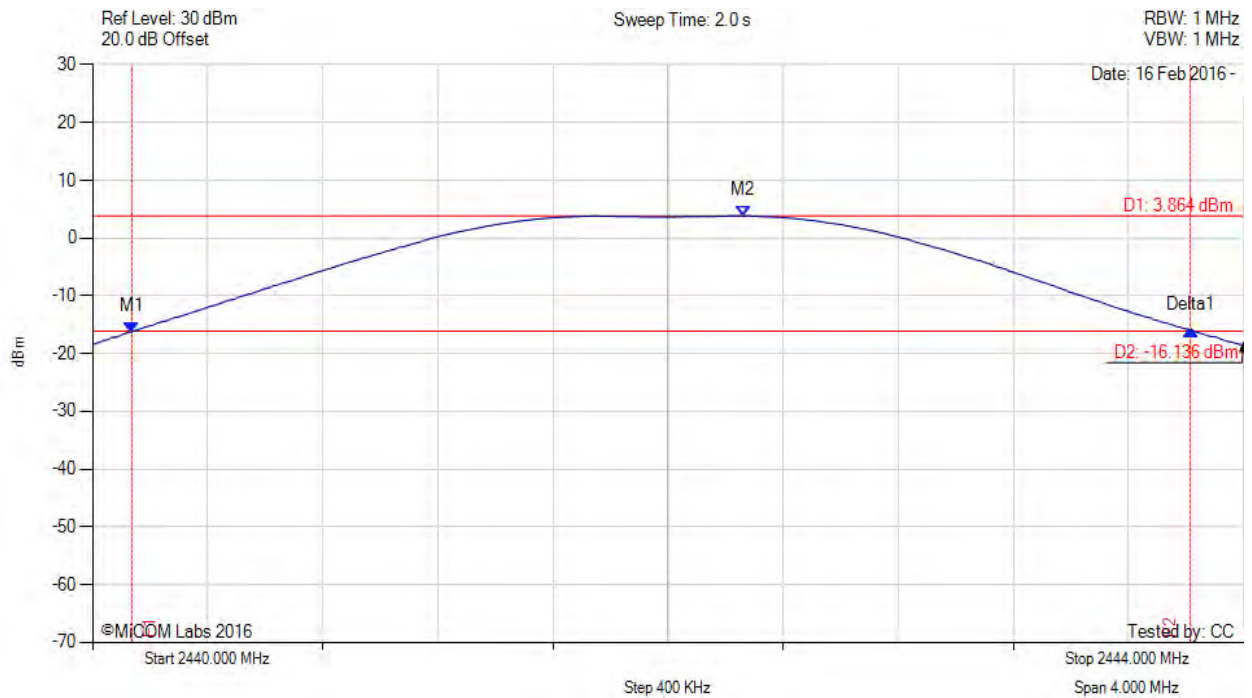

Analyzer Setup	Marker:Frequency:Amplitude	Test Results
Detector = MAX PEAK Sweep Count = 0 RF Atten (dB) = 20 Trace Mode = VIEW	M1 : 2440.136 MHz : -16.266 dBm M2 : 2442.261 MHz : 3.864 dBm Delta1 : 3.679 MHz : 0.323 dB	Channel Power: 4.27 dBm Limit: 30.00 dBm Margin: dB

[back to matrix](#)

This test report may be reproduced in full only. The document may only be updated by MiCOM Labs personnel. All changes will be noted in the Document History section of the report.



Title: Aruba Networks, Inc. APIN0314 & APIN0315
To: FCC Part 15.247 (DTS) & IC RSS-247
Serial #: ARUB204-U2 Rev A Bluetooth BLE
Issue Date: 4th April 2016
Page: 48 of 62

PEAK OUTPUT POWER



Variant: BLE, Channel: 2480.00 MHz, Chain a, Temp: Ambient, Voltage: 55 Vdc

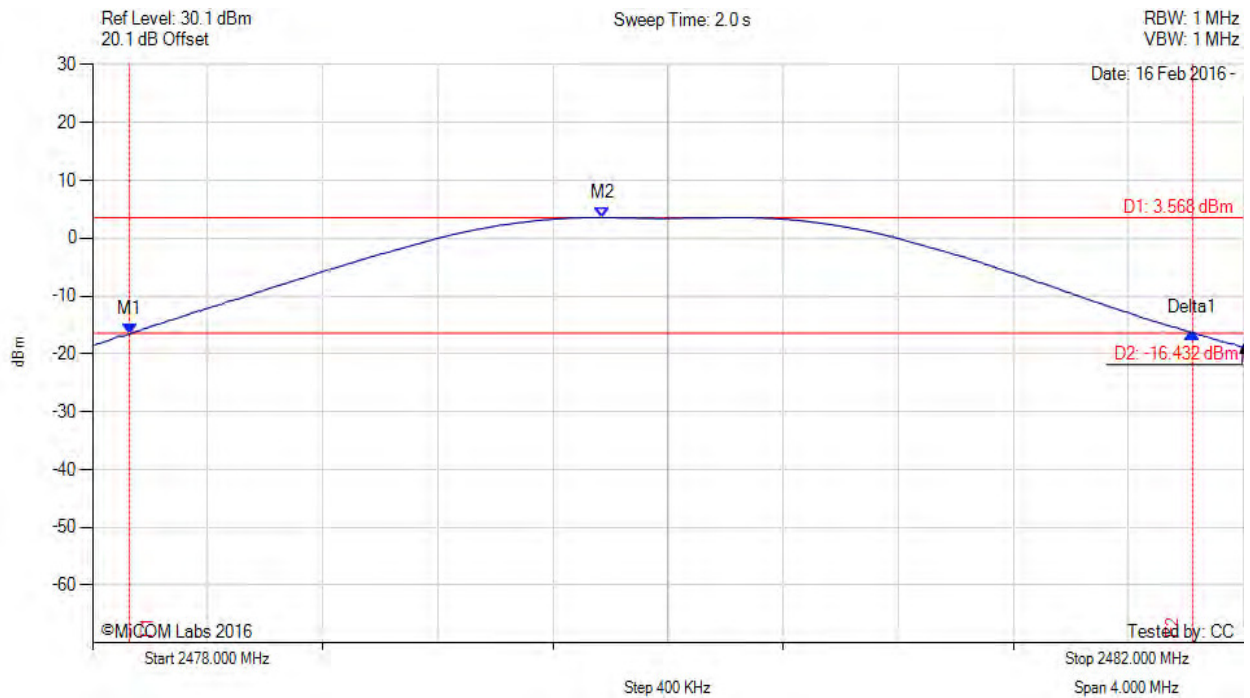

Analyzer Setup	Marker:Frequency:Amplitude	Test Results
Detector = MAX PEAK Sweep Count = 0 RF Atten (dB) = 20 Trace Mode = VIEW	M1 : 2478.128 MHz : -16.564 dBm M2 : 2479.772 MHz : 3.568 dBm Delta1 : 3.695 MHz : 0.197 dB	Channel Power: 3.87 dBm Limit: 30.00 dBm Margin: dB

[back to matrix](#)

This test report may be reproduced in full only. The document may only be updated by MiCOM Labs personnel. All changes will be noted in the Document History section of the report.



A.3. Emissions

A.3.1. Conducted Emissions

A.3.1.1. Conducted Spurious Emissions

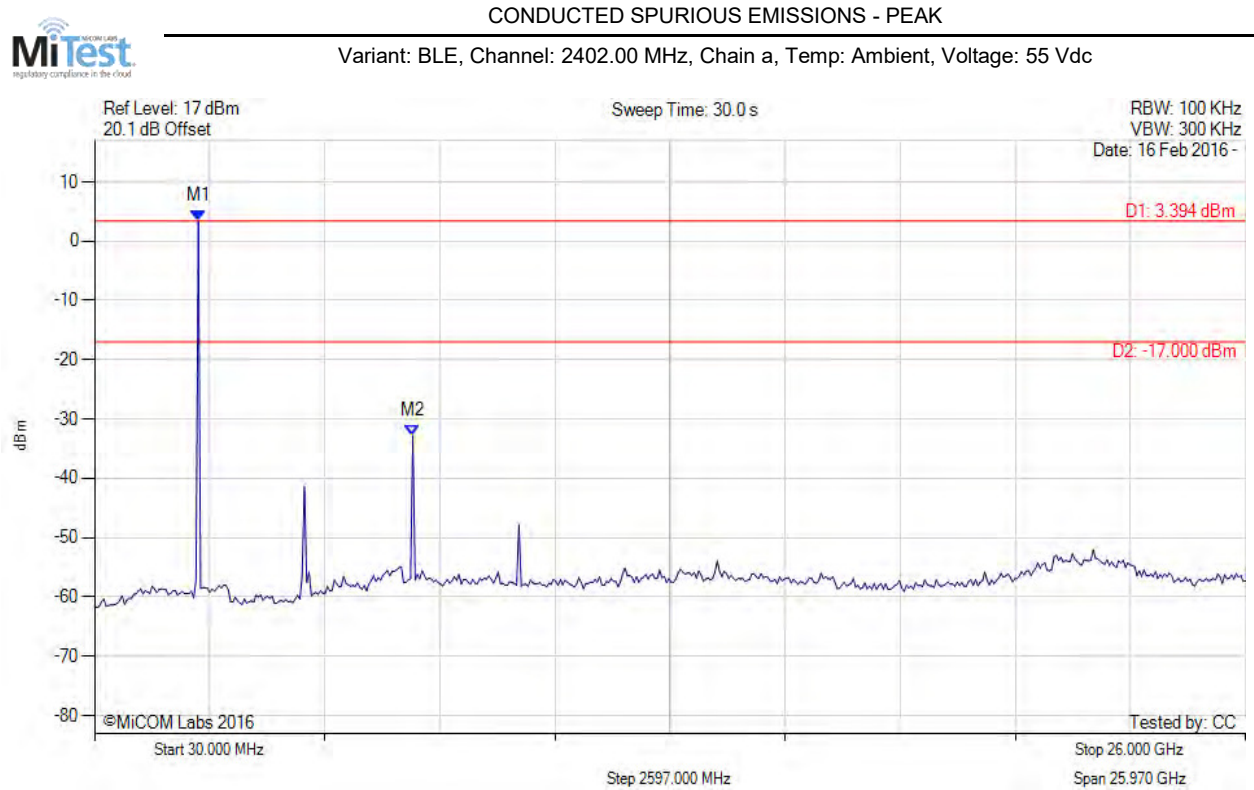

Analyzer Setup	Marker:Frequency:Amplitude	Test Results
Detector = MAX PEAK Sweep Count = 0 RF Atten (dB) = 10 Trace Mode = VIEW	M1 : 2371.984 MHz : 3.394 dBm M2 : 7212.084 MHz : -32.780 dBm	Limit: -17.00 dB Margin: -15.78 dB

[back to matrix](#)

This test report may be reproduced in full only. The document may only be updated by MiCOM Labs personnel. All changes will be noted in the Document History section of the report.



Title: Aruba Networks, Inc. APIN0314 & APIN0315
To: FCC Part 15.247 (DTS) & IC RSS-247
Serial #: ARUB204-U2 Rev A Bluetooth BLE
Issue Date: 4th April 2016
Page: 50 of 62

CONDUCTED SPURIOUS EMISSIONS - PEAK



Variant: BLE, Channel: 2442.00 MHz, Chain a, Temp: Ambient, Voltage: 55 Vdc

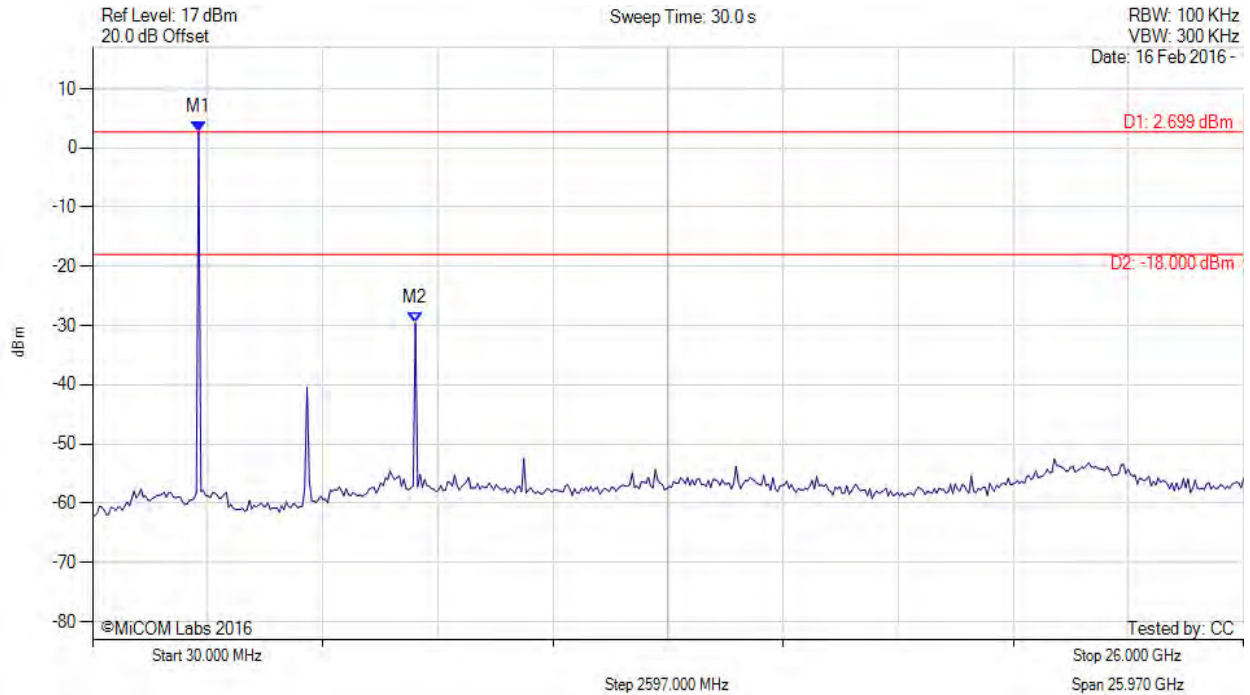

Analyzer Setup	Marker:Frequency:Amplitude	Test Results
Detector = MAX PEAK Sweep Count = 0 RF Atten (dB) = 10 Trace Mode = VIEW	M1 : 2424.028 MHz : 2.699 dBm M2 : 7316.172 MHz : -29.557 dBm	Limit: -18.00 dBm Margin: -11.56 dB

[back to matrix](#)

This test report may be reproduced in full only. The document may only be updated by MiCOM Labs personnel. All changes will be noted in the Document History section of the report.



Title: Aruba Networks, Inc. APIN0314 & APIN0315
To: FCC Part 15.247 (DTS) & IC RSS-247
Serial #: ARUB204-U2 Rev A Bluetooth BLE
Issue Date: 4th April 2016
Page: 51 of 62

CONDUCTED SPURIOUS EMISSIONS - PEAK



Variant: BLE, Channel: 2480.00 MHz, Chain a, Temp: Ambient, Voltage: 55 Vdc

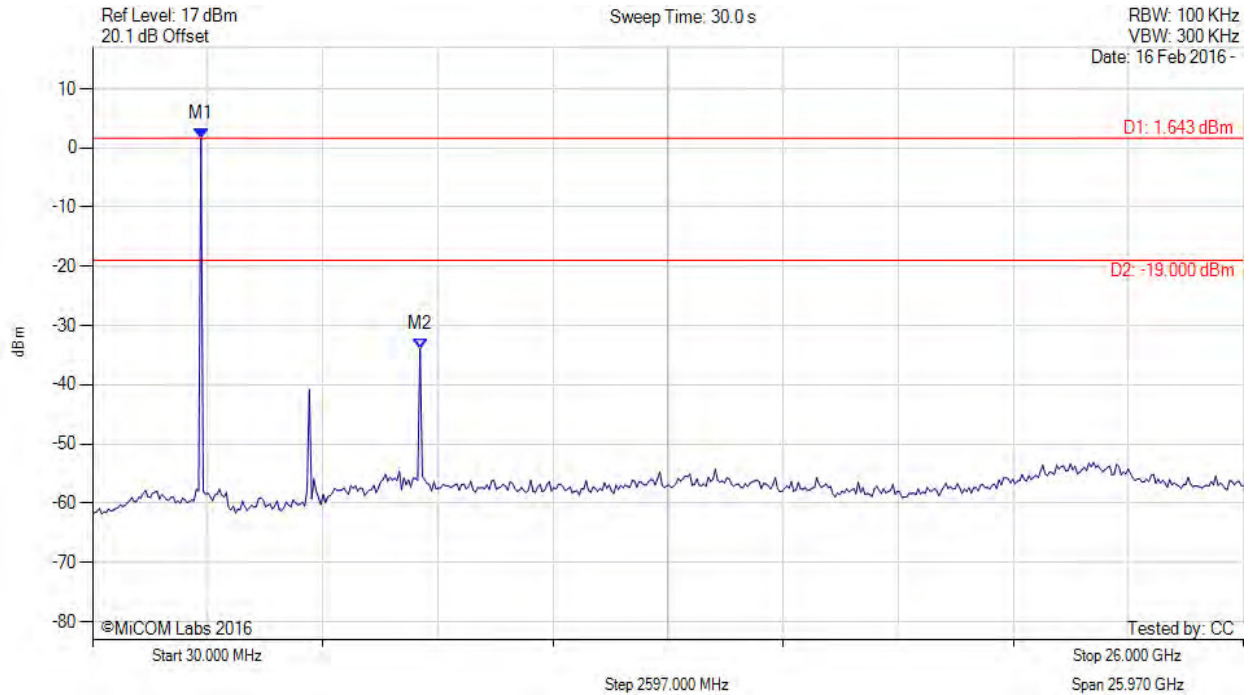

Analyzer Setup	Marker:Frequency:Amplitude	Test Results
Detector = MAX PEAK Sweep Count = 0 RF Atten (dB) = 10 Trace Mode = VIEW	M1 : 2476.072 MHz : 1.643 dBm M2 : 7420.261 MHz : -33.880 dBm	Limit: -19.00 dBm Margin: -14.88 dB

[back to matrix](#)

This test report may be reproduced in full only. The document may only be updated by MiCOM Labs personnel. All changes will be noted in the Document History section of the report.



A.3.1.2. Conducted Band-Edge Emissions

Low Band-Edge Emissions

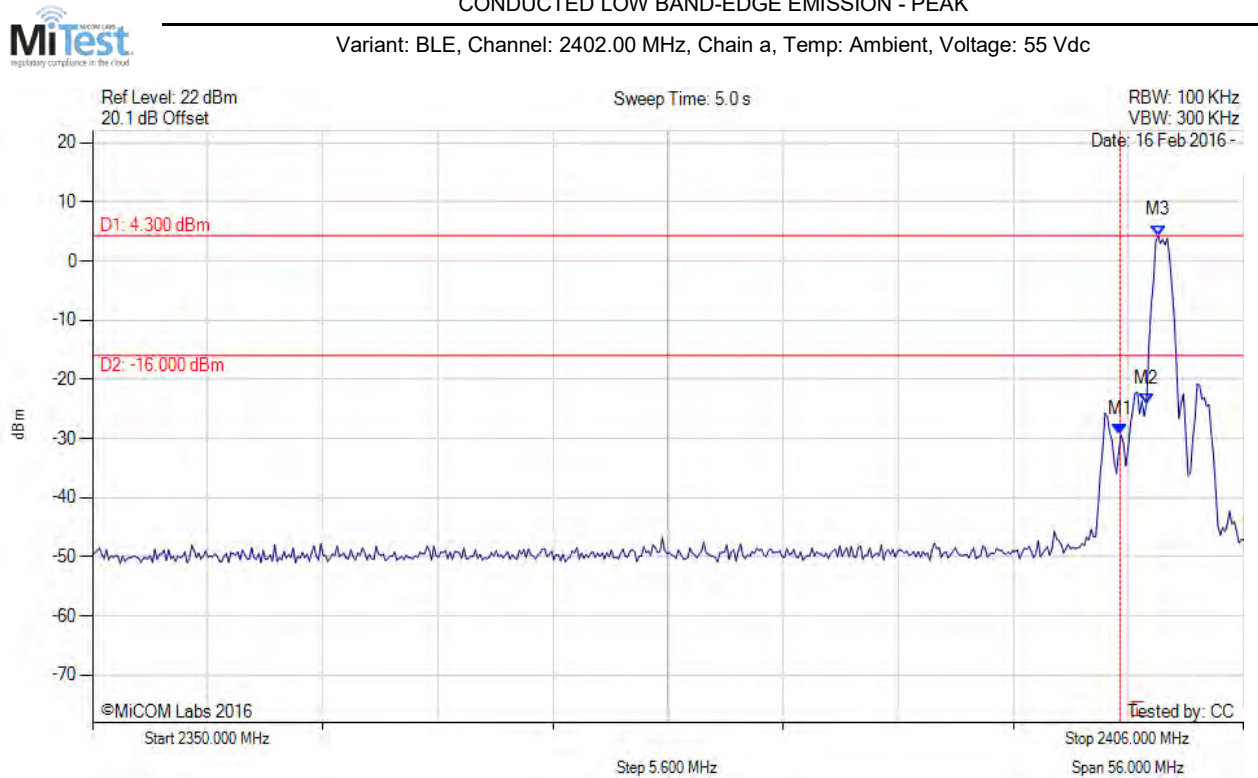

Analyzer Setup	Marker:Frequency:Amplitude	Test Results
Detector = MAX PEAK Sweep Count = 0 RF Atten (dB) = 20 Trace Mode = VIEW	M1 : 2400.000 MHz : -29.401 dBm M2 : 2401.287 MHz : -24.107 dBm M3 : 2401.848 MHz : 4.300 dBm	Channel Frequency: 2402.00 MHz

[back to matrix](#)

This test report may be reproduced in full only. The document may only be updated by MiCOM Labs personnel. All changes will be noted in the Document History section of the report.



High Band-Edge Emissions



CONDUCTED HIGH BAND-EDGE EMISSION - PEAK

Variant: BLE, Channel: 2480.00 MHz, Chain a, Temp: Ambient, Voltage: 55 Vdc

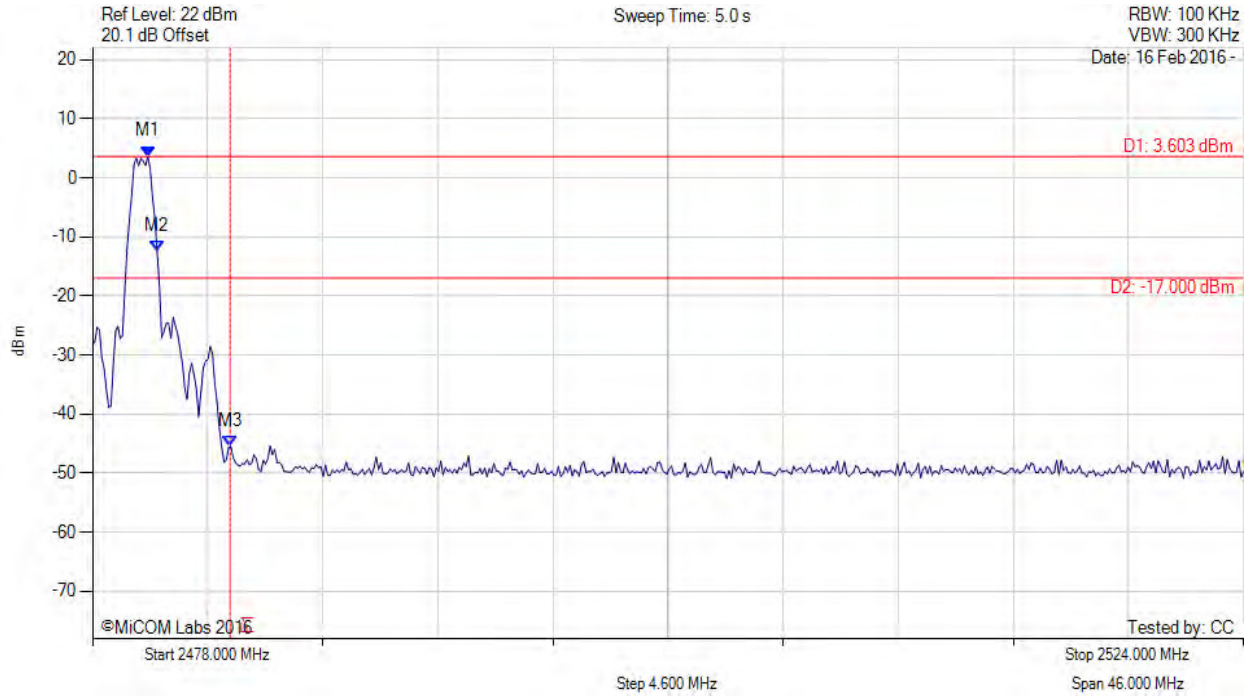

Analyzer Setup	Marker:Frequency:Amplitude	Test Results
Detector = MAX PEAK Sweep Count = 0 RF Atten (dB) = 20 Trace Mode = VIEW	M1 : 2480.212 MHz : 3.603 dBm M2 : 2480.581 MHz : -12.468 dBm M3 : 2483.500 MHz : -45.543 dBm	Channel Frequency: 2480.00 MHz

[back to matrix](#)

This test report may be reproduced in full only. The document may only be updated by MiCOM Labs personnel. All changes will be noted in the Document History section of the report.



A.4. Power Spectral Density



POWER SPECTRAL DENSITY - PEAK

Variant: BLE, Channel: 2402.00 MHz, Chain a, Temp: Ambient, Voltage: 55 Vdc

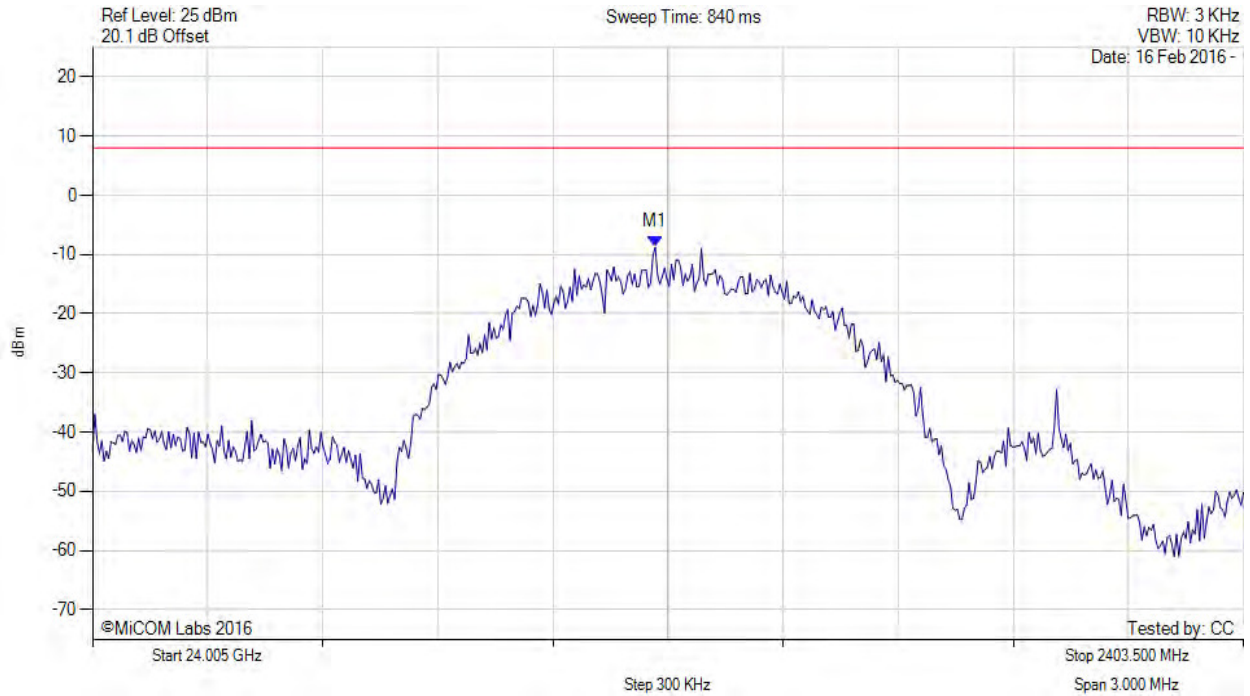

Analyzer Setup	Marker:Frequency:Amplitude	Test Results
Detector = MAX PEAK Sweep Count = 0 RF Atten (dB) = 20 Trace Mode = VIEW	M1 : 2401.967 MHz : -8.760 dBm	Limit: ≤ 8.000 dBm Margin: 16.76 dB

[back to matrix](#)

This test report may be reproduced in full only. The document may only be updated by MiCOM Labs personnel. All changes will be noted in the Document History section of the report.



Title: Aruba Networks, Inc. APIN0314 & APIN0315
To: FCC Part 15.247 (DTS) & IC RSS-247
Serial #: ARUB204-U2 Rev A Bluetooth BLE
Issue Date: 4th April 2016
Page: 55 of 62

POWER SPECTRAL DENSITY - PEAK



Variant: BLE, Channel: 2442.00 MHz, Chain a, Temp: Ambient, Voltage: 55 Vdc

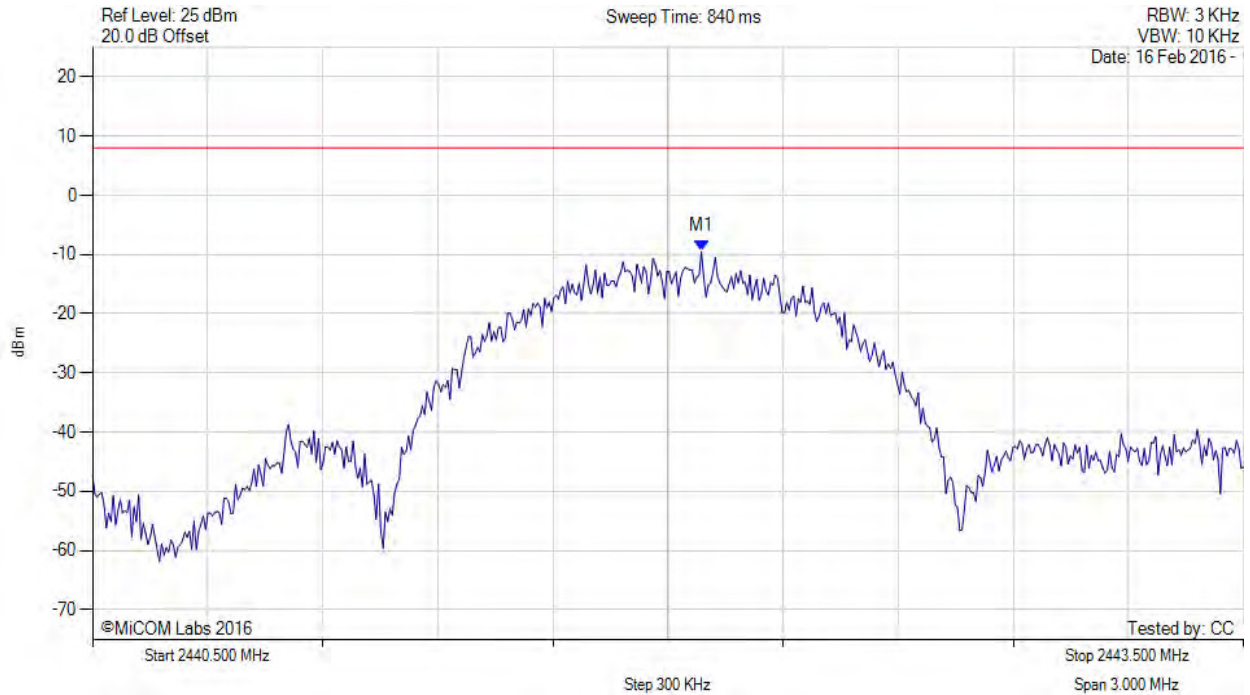

Analyzer Setup	Marker: Frequency: Amplitude	Test Results
Detector = MAX PEAK Sweep Count = 0 RF Atten (dB) = 20 Trace Mode = VIEW	M1 : 2442.087 MHz : -9.486 dBm	Limit: ≤ 8.000 dBm Margin: 17.49 dB

[back to matrix](#)

This test report may be reproduced in full only. The document may only be updated by MiCOM Labs personnel. All changes will be noted in the Document History section of the report.



Title: Aruba Networks, Inc. APIN0314 & APIN0315
To: FCC Part 15.247 (DTS) & IC RSS-247
Serial #: ARUB204-U2 Rev A Bluetooth BLE
Issue Date: 4th April 2016
Page: 56 of 62

POWER SPECTRAL DENSITY - PEAK



Variant: BLE, Channel: 2480.00 MHz, Chain a, Temp: Ambient, Voltage: 55 Vdc

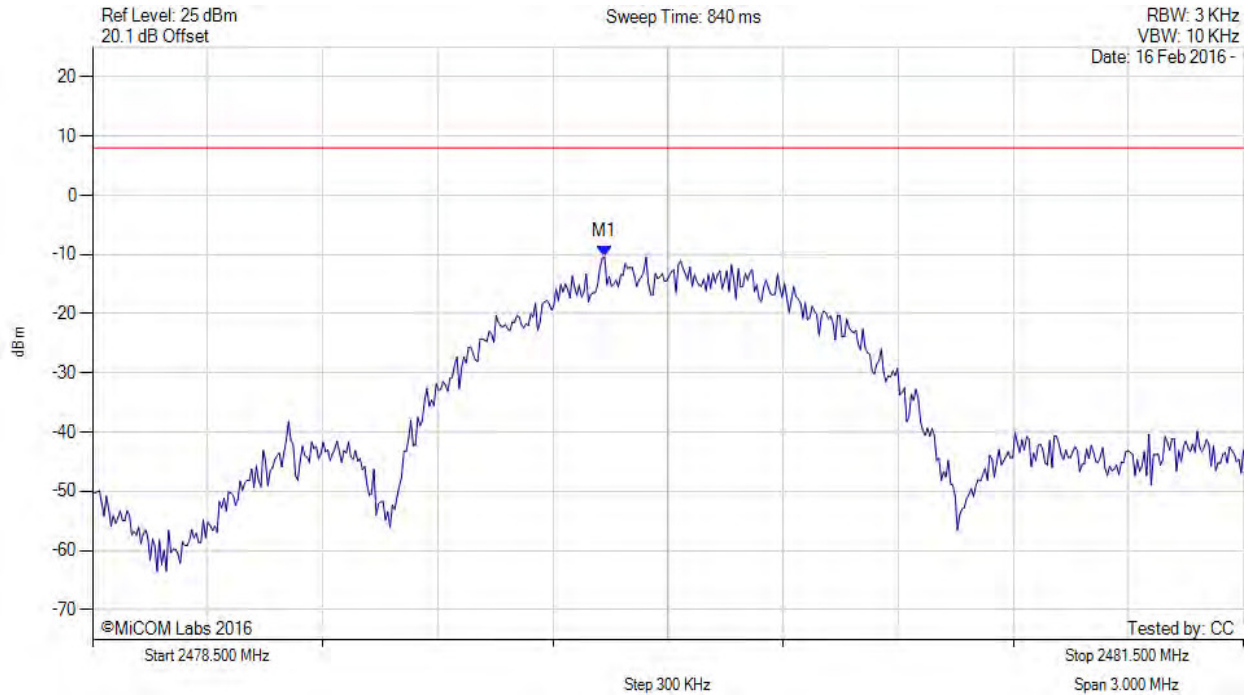

Analyzer Setup	Marker: Frequency: Amplitude	Test Results
Detector = MAX PEAK Sweep Count = 0 RF Atten (dB) = 20 Trace Mode = VIEW	M1 : 2479.835 MHz : -10.363 dBm	Limit: ≤ 8.000 dBm Margin: 18.36 dB

[back to matrix](#)

This test report may be reproduced in full only. The document may only be updated by MiCOM Labs personnel. All changes will be noted in the Document History section of the report.



Title: Aruba Networks, Inc. APIN0314 & APIN0315
To: FCC Part 15.247 (DTS) & IC RSS-247
Serial #: ARUB204-U2 Rev A Bluetooth BLE
Issue Date: 4th April 2016
Page: 57 of 62

A.5. Radiated Spurious Emissions

A.5.1. Restricted Band Emissions

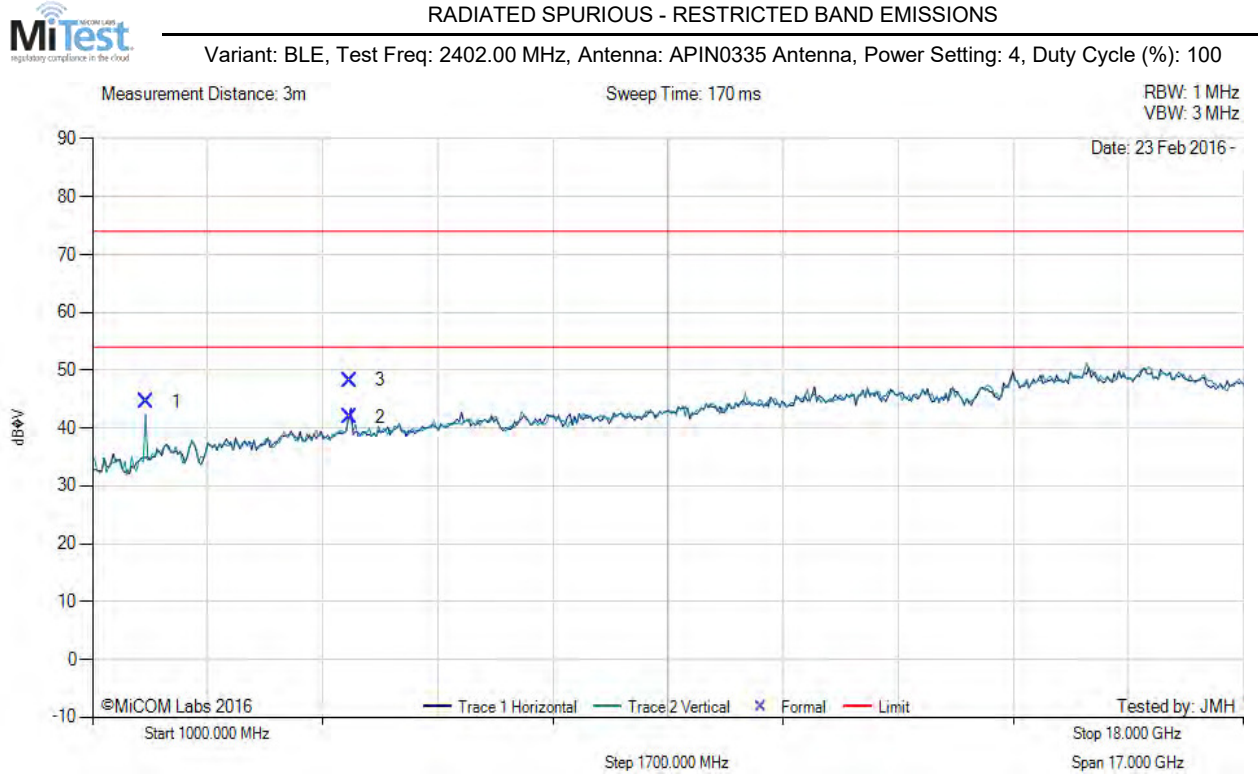

Num	Frequency MHz	Raw dBμV	Cable Loss	AF dB	Level dBμV/m	Measurement Type	Pol	Hgt cm	Azt Deg	Limit dBμV/m	Margin dB	Pass /Fail
1	1792.63	55.86	2.46	-13.78	44.54	Peak (NRB)	Vertical	150	117	--	--	Pass
2	4806.03	49.45	3.50	-11.12	41.83	Max Avg	Horizontal	146	278	54.0	-12.2	Pass
3	4806.03	55.90	3.50	-11.12	48.28	Max Peak	Horizontal	146	278	74.0	-25.7	Pass

Test Notes: EUT on 150cm table powered by laptop. Connected to laptop inside chamber

[back to matrix](#)

This test report may be reproduced in full only. The document may only be updated by MiCOM Labs personnel. All changes will be noted in the Document History section of the report.



Title: Aruba Networks, Inc. APIN0314 & APIN0315
To: FCC Part 15.247 (DTS) & IC RSS-247
Serial #: ARUB204-U2 Rev A Bluetooth BLE
Issue Date: 4th April 2016
Page: 58 of 62



RADIATED SPURIOUS - RESTRICTED BAND EMISSIONS

Variant: BLE, Test Freq: 2440.00 MHz, Antenna: APIN0335 Antenna, Power Setting: 4, Duty Cycle (%): 100

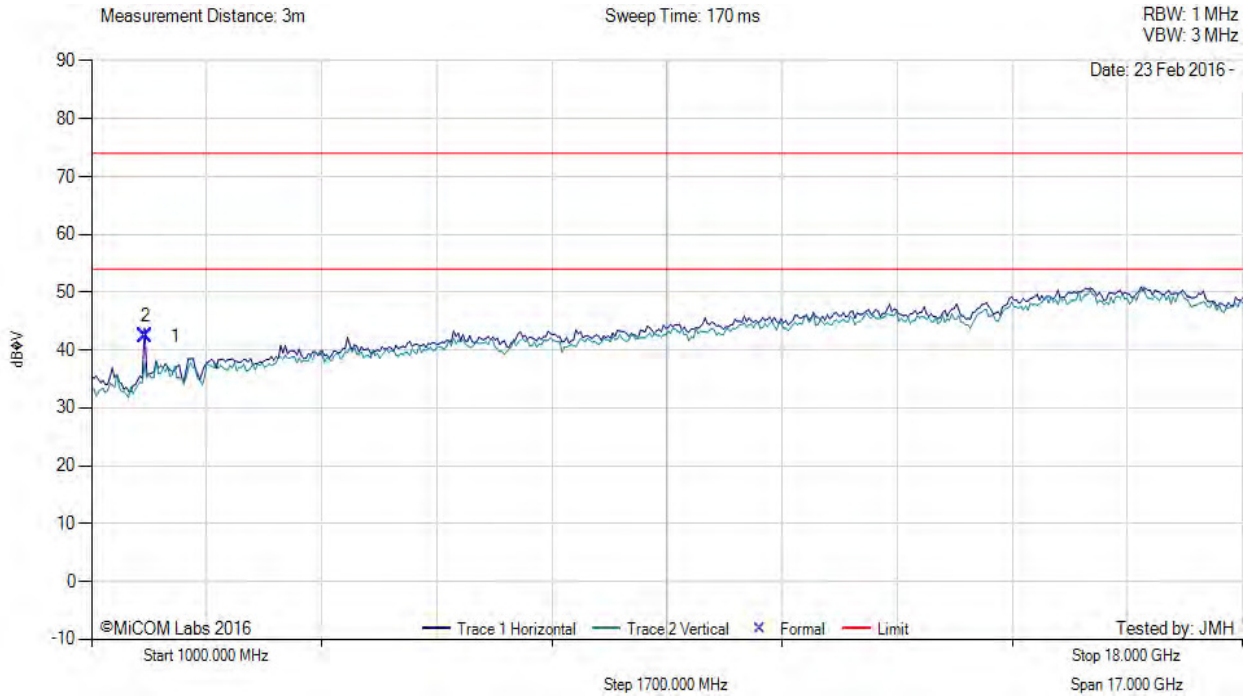

Num	Frequency MHz	Raw dBµV	Cable Loss	AF dB	Level dBµV/m	Measurement Type	Pol	Hgt cm	Azt Deg	Limit dBµV/m	Margin dB	Pass /Fail
1	1792.99	53.77	2.46	-13.78	42.45	Peak (NRB)	Horizontal	151	360	--	--	Pass
2	1792.99	53.77	2.46	-13.78	42.45	Peak (NRB)	Horizontal	151	360	--	--	Pass

Test Notes: EUT on 150cm table powered by laptop. Connected to laptop inside chamber

[back to matrix](#)

This test report may be reproduced in full only. The document may only be updated by MiCOM Labs personnel. All changes will be noted in the Document History section of the report.



Title: Aruba Networks, Inc. APIN0314 & APIN0315
To: FCC Part 15.247 (DTS) & IC RSS-247
Serial #: ARUB204-U2 Rev A Bluetooth BLE
Issue Date: 4th April 2016
Page: 59 of 62



RADIATED SPURIOUS - RESTRICTED BAND EMISSIONS

Variant: BLE, Test Freq: 2462.00 MHz, Antenna: APIN0335 Antenna, Power Setting: 4, Duty Cycle (%): 100

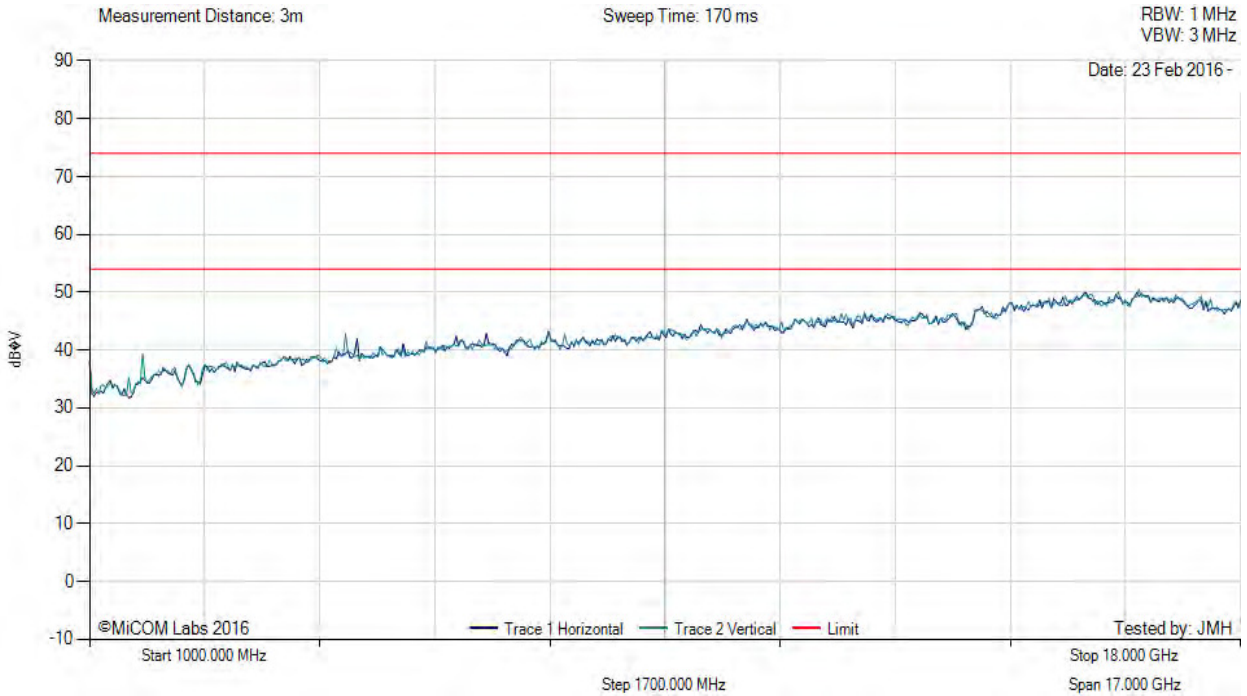

There are no emissions found within 6dB of the limit line.

Test Notes: EUT on 150cm table powered by laptop. Connected to laptop inside chamber

[back to matrix](#)

This test report may be reproduced in full only. The document may only be updated by MiCOM Labs personnel. All changes will be noted in the Document History section of the report.



A.5.2. Restricted Band-Edge Emissions



RADIATED - LOWER RESTRICTED BAND-EDGE EMISSIONS

Variant: BLE, Test Freq: 2402.00 MHz, Antenna: Aruba Networks Metal Sheet, Power Setting: 4

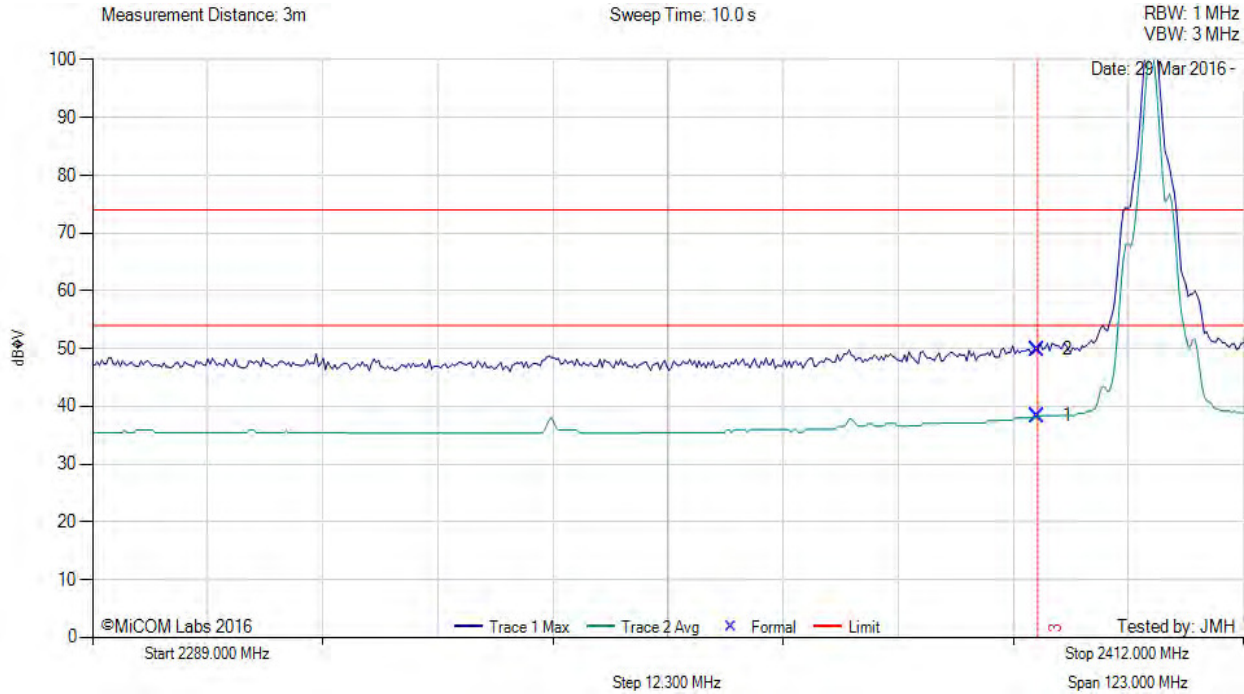

Num	Frequency MHz	Raw dBµV	Cable Loss	AF dB	Level dBµV/m	Measurement Type	Pol	Hgt cm	Azt Deg	Limit dBµV/m	Margin dB	Pass /Fail
1	2390.00	3.66	2.69	32.04	38.39	Max Avg	Horizontal	117	41	54.0	-15.6	Pass
2	2390.00	15.12	2.69	32.04	49.85	Max Peak	Horizontal	117	41	74.0	-24.2	Pass
3	2390.00	--	--	--	--	Band Egde	--	--	--	--	--	--

Test Notes: EUT on 150cm table powered by cc debugger connected to laptop

[back to matrix](#)

This test report may be reproduced in full only. The document may only be updated by MiCOM Labs personnel. All changes will be noted in the Document History section of the report.



Title: Aruba Networks, Inc. APIN0314 & APIN0315
To: FCC Part 15.247 (DTS) & IC RSS-247
Serial #: ARUB204-U2 Rev A Bluetooth BLE
Issue Date: 4th April 2016
Page: 61 of 62



RADIATED - UPPER RESTRICTED BAND-EDGE EMISSIONS

Variant: BLE, Test Freq: 2480.00 MHz, Antenna: Aruba Networks Metal Sheet, Power Setting: 4

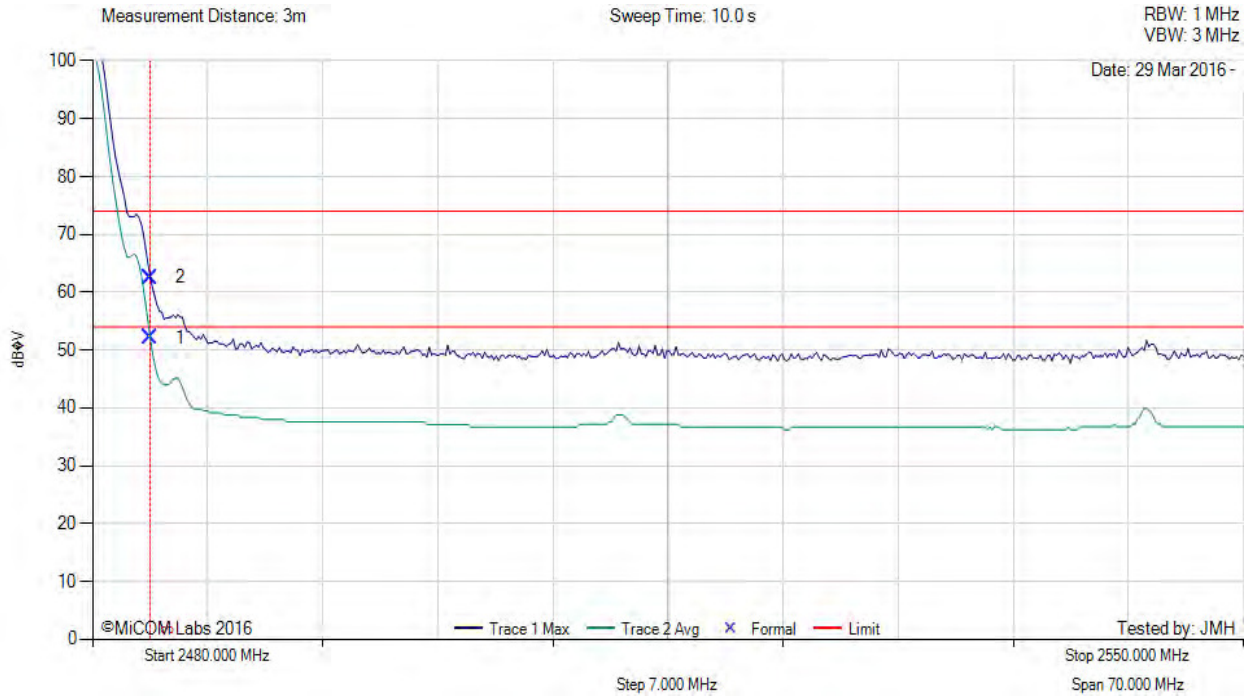

Num	Frequency MHz	Raw dBμV	Cable Loss	AF dB	Level dBμV/m	Measurement Type	Pol	Hgt cm	Azt Deg	Limit dBμV/m	Margin dB	Pass /Fail
1	2483.50	17.03	2.73	32.37	52.13	Max Avg	Horizontal	151	46	54.0	-1.9	Pass
2	2483.50	27.49	2.73	32.37	62.59	Max Peak	Horizontal	151	46	74.0	-11.4	Pass
3	2483.50	--	--	--	--	Band Edge	--	--	--	--	--	--

Test Notes: EUT on 150cm table powered by cc debugger connected to laptop

[back to matrix](#)

This test report may be reproduced in full only. The document may only be updated by MiCOM Labs personnel. All changes will be noted in the Document History section of the report.



575 Boulder Court
Pleasanton, California 94566, USA
Tel: +1 (925) 462 0304
Fax: +1 (925) 462 0306
www.micomlabs.com