



FCC RF Test Report

APPLICANT : Hewlett Packard Enterprise Company
EQUIPMENT : Wireless Access Point
BRAND NAME : aruba
MODEL NAME : APIN0304, APIN0305
MARKETING NAME : APIN0304, APIN0305
FCC ID : Q9DAPIN0304305
STANDARD : FCC Part 15 Subpart C §15.247
CLASSIFICATION : (DTS) Digital Transmission System

The product was received on Jul. 07, 2016 and testing was completed on Sep. 07, 2016. We, SPORTON INTERNATIONAL (KUNSHAN) INC., would like to declare that the tested sample has been evaluated in accordance with the test procedures and has been in compliance with the applicable technical standards.

The test results in this report apply exclusively to the tested model / sample. Without written approval of SPORTON INTERNATIONAL (KUNSHAN) INC., the test report shall not be reproduced except in full.

Prepared by: James Huang / Manager

Approved by: Jones Tsai / Manager



SPORTON INTERNATIONAL (KUNSHAN) INC.
No. 3-2, PingXiang Road, Kunshan, Jiangsu Province, P. R. China



TABLE OF CONTENTS

SUMMARY OF TEST RESULT 4

1 GENERAL DESCRIPTION..... 5

1.1 Applicant 5

1.2 Manufacturer 5

1.3 Product Feature of Equipment Under Test..... 5

1.4 Product Specification of Equipment Under Test..... 6

1.5 Sample List 7

1.6 Modification of EUT 8

1.7 Testing Location 8

1.8 Applicable Standards..... 9

1.9 Test Condition..... 9

2 TEST CONFIGURATION OF EQUIPMENT UNDER TEST..... 10

2.1 Descriptions of Test Mode 10

2.2 Test Mode 11

2.3 Connection Diagram of Test System 12

2.4 Support Unit used in test configuration and system 15

2.5 EUT Operation Test Setup 16

2.6 Measurement Results Explanation Example..... 17

3 TEST RESULT 18

3.1 6dB and 99% Bandwidth Measurement 18

3.2 Peak Output Power Measurement 23

3.3 Power Spectral Density Measurement 24

3.4 Conducted Band Edges and Spurious Emission Measurement 29

3.5 Radiated Band Edges and Spurious Emission Measurement 34

3.6 AC Conducted Emission Measurement..... 38

3.7 Antenna Requirements 42

4 LIST OF MEASURING EQUIPMENT..... 43

5 UNCERTAINTY OF EVALUATION..... 44

APPENDIX A. CONDUCTED TEST RESULTS

APPENDIX B. RADIATED TEST RESULTS

APPENDIX C. RADIATED SPURIOUS EMISSION PLOTS

APPENDIX D. DUTY CYCLE PLOTS

APPENDIX E. SETUP PHOTOGRAPHS



REVISION HISTORY

REPORT NO.	VERSION	DESCRIPTION	ISSUED DATE
FR670709A	Rev. 01	Initial issue of report	Sep. 20, 2016



SUMMARY OF TEST RESULT

Report Section	FCC Rule	IC Rule	Description	Limit	Result	Remark
3.1	15.247(a)(2)	RSS-247 5.2(1)	6dB Bandwidth	$\geq 0.5\text{MHz}$	Pass	-
3.1	-	RSS-Gen 6.6	99% Bandwidth	-	Pass	-
3.2	15.247(b)(3)	RSS-247 A5.4(4)	Peak Output Power	$\leq 30\text{dBm}$	Pass	-
3.3	15.247(e)	RSS-247 5.2(2)	Power Spectral Density	$\leq 8\text{dBm}/3\text{kHz}$	Pass	-
3.4	15.247(d)	RSS-247 5.5	Conducted Band Edges and Spurious Emission	$\leq 20\text{dBc}$	Pass	-
3.5	15.247(d)	RSS-247 5.5	Radiated Band Edges and Spurious Emission	15.209(a) & 15.247(d)	Pass	Under limit 1.14 dB at 4878.000 MHz
3.6	15.207	RSS-GEN 8.8	AC Conducted Emission	15.207(a)	Pass	Under limit 7.50 dB at 0.176 MHz
3.7	15.203 & 15.247(b)	N/A	Antenna Requirement	N/A	Pass	-



1 General Description

1.1 Applicant

Hewlett Packard Enterprise Company
3000 Hanover Street, Palo Alto, CA 94304

1.2 Manufacturer

Hewlett Packard Enterprise Company
3000 Hanover Street, Palo Alto, CA 94304

1.3 Product Feature of Equipment Under Test

Product Feature	
Equipment	Wireless Access Point
Brand Name	aruba
Model Name	APIN0304, APIN0305
Marketing Name	APIN0304, APIN0305
FCC ID	Q9DAPIN0304305
S/N	APIN0304: CNBRAAA00Z (For RF Conducted and Radiation) CNBYJSR00M (For Conduction) APIN0305: CNBRAAA00Z (For RF Conducted) CNBRAAA031 (For Radiation) CNBYJSR00M (For Conduction)
EUT supports Radios application	WLAN 2.4GHz 802.11b/g/n HT20/HT40 WLAN 5GHz 802.11a/n HT20/HT40 WLAN 5GHz 802.11ac VHT20/VHT40/VHT80 Bluetooth v4.0 LE
SW Version	6.5.1.0 build56105
EUT Stage	Identical Prototype

Remark: The above EUT's information was declared by manufacturer. Please refer to the specifications or user's manual for more detailed description.



1.4 Product Specification of Equipment Under Test

Standards-related Product Specification	
Tx/Rx Frequency Range	2402 MHz ~ 2480 MHz
Number of Channels	40
Carrier Frequency of Each Channel	40 Channel(37 hopping + 3 advertising channel)
Maximum Output Power to Antenna	0.42 dBm (0.0011 W)
99% Occupied Bandwidth	1.053MHz
Antenna Type	Internal Antenna
Antenna Gain	For APIN0304 Gain 4.50 dBi For APIN0305 Gain 3.40 dBi
Type of Modulation	Bluetooth LE : GFSK



1.5 Sample List

There are two model names of EUT. Model APIN0305 is designed with built in antennas, and model APIN0304 with three RP-SMA connectors for external antennas. For model APIN0304, it has nine types of antenna as below table:

	type	Description	Gain	Polorization
1	AP-ANT-1W	2.4-2.5GHz/5GHz, 5.0dBi Tri-Band, Omni-Directional Antenna	3.8dBi @2.4GHz; 5.8dB @5.8GHz	Linear vertical
2	AP-ANT-13B	downtilt omni, dual-band	4.4dBi @2.4GHz; 3.3dB @5.8GHz	Linear vertical
3	AP-ANT-19,	Dual Band Omnidirectional	3dBi @2.4GHz; 6dB @5.8GHz	vertical
4	AP-ANT-20W,	2.4- and 5-GHz dual-band omni directional	2dBi @2.4GHz; 2dB @5.8GHz	Linear vertical
5	AP-ANT-16,	Triple Element Downtilt Omni, Dual-Band	3.9dBi @2.4GHz; 4.7dB @5.8GHz	vertical
6	AP-ANT-25A	2.4- and 5-GHz dual polarized sector antenna	5dBi @2.4GHz; 5dB @5.8GHz	slant +/-45°
7	AP-ANT-35A	2.4- and 5-GHz dual polarized sector antenna	5dBi @2.4GHz; 5dB @5.8GHz	slant +/-45°
8	AP-ANT-28	2.4- and 5-GHz dual-polarized sector antenna	7.5dBi @2.4GHz; 7.5dB @5.8GHz	slant +/-45°
9	AP-ANT-38	2.4- and 5-GHz dual-polarized sector antenna	7.5dBi @2.4GHz; 7.5dB @5.8GHz	slant +/-45°

For model APIN0304, we only evaluate testing for the antenna (AP-ANT-13B and AP-ANT-28) with the maximum antenna gain.

The detail test sample list as below table:

Sample	Mode name	Antenna Type
Sample 1	APIN0304	AP-ANT-13B(Omnidirectional antenna)
Sample 2	APIN0304	AP-ANT-28(Directional antenna)
Sample 3	APIN0305	Internal Antenna



1.6 Modification of EUT

No modifications are made to the EUT during all test items.

1.7 Testing Location

Test Site	SPORTON INTERNATIONAL (KUNSHAN) INC.			
Test Site Location	No. 3-2, PingXiang Road, Kunshan, Jiangsu Province, P. R. China TEL: +86-0512-5790-0158 FAX: +86-0512-5790-0958			
Test Site No.	Sporton Site No.			FCC/IC Registration No.
	TH01-KS	03CH03-KS	CO01-KS	306251/4086E

Note: The test site complies with ANSI C63.4 2014 requirement.



1.8 Applicable Standards

According to the specifications of the manufacturer, the EUT must comply with the requirements of the following standards:

- ♦ FCC Part 15 Subpart C §15.247
- ♦ FCC KDB Publication No. 558074 D01 DTS Meas. Guidance v03r05
- ♦ ANSI C63.10-2013
- ♦ IC RSS-247 Issue 1
- ♦ IC RSS-Gen Issue 4

Remark:

1. All test items were verified and recorded according to the standards and without any deviation during the test.
2. This EUT has also been tested and complied with the requirements of FCC Part 15, Subpart B, recorded in a separate test report.

1.9 Test Condition

Normal Voltage	DC 12V for Adapter DC 57V for POE
Normal Temperature	20°C
Extreme Temperature	0°C and 50°C

Note: The test temperature was between voltage 0°C~50°C by manufacturer requested.



2 Test Configuration of Equipment Under Test

2.1 Descriptions of Test Mode

The RF output power was recorded in the following table:

Channel	Frequency	Bluetooth LE RF Output Power	
		Data Rate / Modulation	
		GFSK	
		1Mbps	
Ch00	2402MHz	0.42	dBm
Ch19	2440MHz	0.17	dBm
Ch39	2480MHz	-0.12	dBm

- a. The EUT has been associated with peripherals and configuration operated in a manner tended to maximize its emission characteristics in a typical application. Frequency range investigated: conduction (150 kHz to 30 MHz), radiation (9 kHz to the 10th harmonic of the highest fundamental frequency or to 40 GHz, whichever is lower). Pre-scanned tests, X, Y, Z in three orthogonal panels to determine the final configuration (Y plane as worst plane) from all possible combinations.

- b. AC power line Conducted Emission was tested under maximum output power.



2.2 Test Mode

The following summary table is showing all test modes to demonstrate in compliance with the standard.

Summary table of Test Cases	
Test Item	Data Rate / Modulation
	Bluetooth LE / GFSK
Conducted TCs	Mode 1: Bluetooth Tx CH00_2402 MHz_1Mbps
	Mode 2: Bluetooth Tx CH19_2440 MHz_1Mbps
	Mode 3: Bluetooth Tx CH39_2480 MHz_1Mbps
Radiated TCs	Mode 1: Bluetooth Tx CH00_2402 MHz_1Mbps
	Mode 2: Bluetooth Tx CH19_2440 MHz_1Mbps
	Mode 3: Bluetooth Tx CH39_2480 MHz_1Mbps
AC Conducted Emission	Mode 1: Bluetooth Link + WLAN Link (2.4G) + Adapter for Sample 1
	Mode 2: Bluetooth Link + WLAN Link (2.4G) + POE for Sample 2
	Mode 3: Bluetooth Link + WLAN Link (2.4G) + Adapter for Sample 3
Remark:	
1. The worst case of conducted emission is mode 3; only the test data of it was reported.	
2. For Radiated TCs, the tests were performed with adapter for Sample 1, Sample 2 and Sample 3. Only the worst case verified the POE adapter mode.	

2.3 Connection Diagram of Test System

<Conducted Mode>

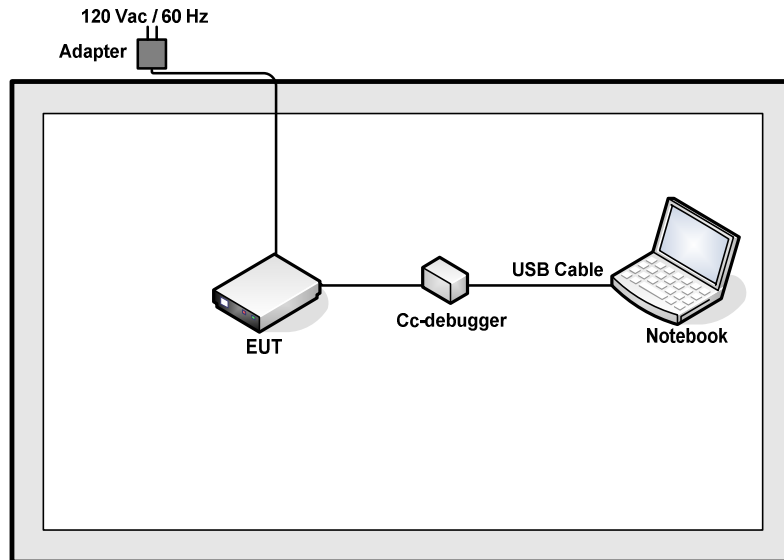

<Bluetooth LE Tx Mode with Adapter>

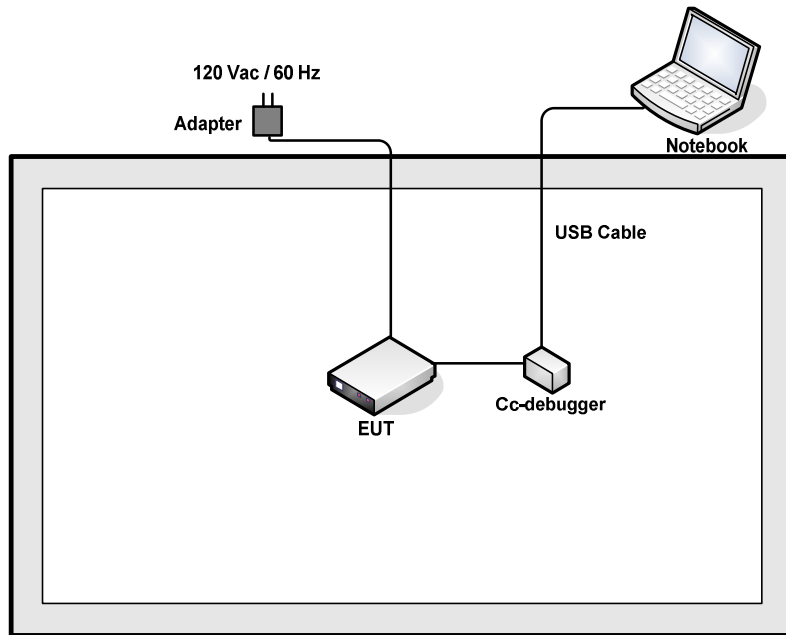

<Bluetooth LE Tx Mode with POE Adapter>

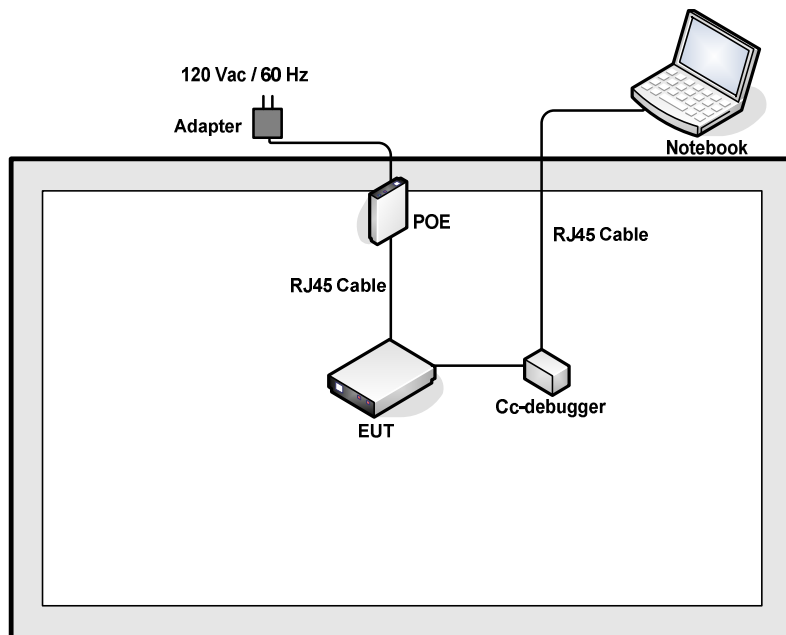

<AC Conducted Emission Mode with Adapter>

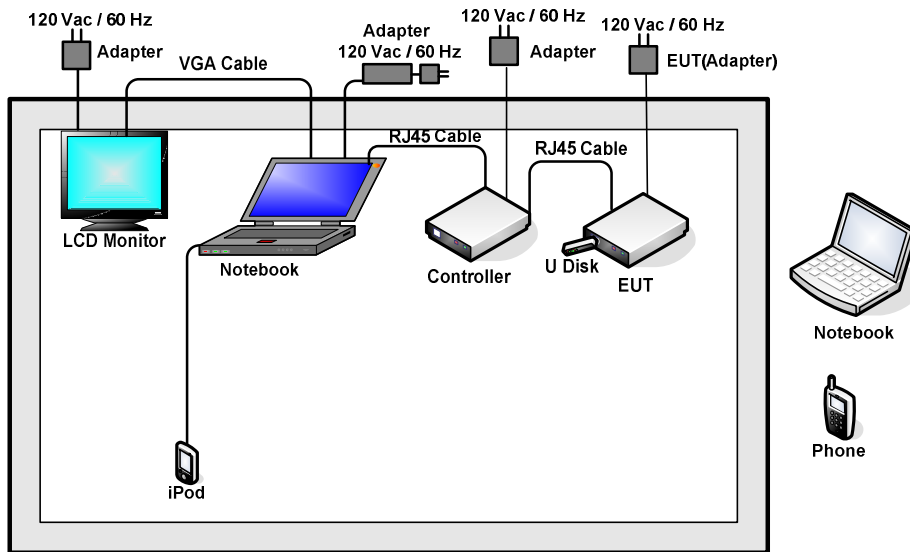

<AC Conducted Emission Mode with POE Adapter>

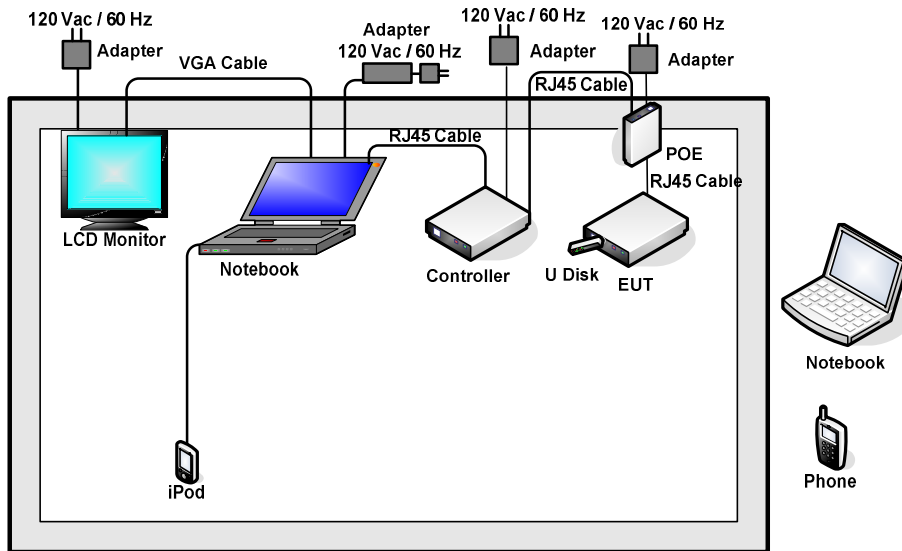



2.4 Support Unit used in test configuration and system

Item	Equipment	Trade Name	Model Name	FCC ID	Data Cable	Power Cord
1.	WLAN AP	D-Link	DIR-855	KA2DIR855A2	N/A	Unshielded, 1.8 m
2.	Notebook	Lenovo	E40	FCC DoC	N/A	AC I/P: Unshielded, 1.2 m DC O/P: Shielded, 1.8 m
3.	Notebook	Lenovo	E49	FCC DoC	N/A	AC I/P: Unshielded, 1.2 m DC O/P: Shielded, 1.8 m
4.	LCD Monitor	Dell	In1930mwC	FCC DoC	Shielded, 1.6 m	Unshielded, 1.8 m
5.	iPod	Apple	A1199	FCC DoC	Shielded, 1.0 m	N/A
6.	Android Phone	ZTE	A1	N/A	N/A	N/A
7.	U Disk	SanDisk	SDCZ51-004G	N/A	N/A	N/A
8.	Controller	Aruba	ARCN0103	N/A	N/A	AC I/P: Unshielded cable, 1.8m
9.	AC Adapter	CUI INC	SDI30-12-U-P209-C1	N/A	N/A	Unshielded cable, 2m
10.	POE	PowerDsine	PD-3501G/AC	N/A	N/A	N/A
11.	Cc-debugger	N/A	N/A	N/A	N/A	N/A
12.	USB Cable	N/A	N/A	N/A	N/A	N/A
13.	RJ45 Cable	N/A	N/A	N/A	N/A	N/A

2.5 EUT Operation Test Setup

For Bluetooth LE test items, an engineering test program was provided and enabled to make EUT transmitting and receiving signals. EUT was connected to spectrum analyzer and cc-debugger, the cc-debugger connect to notebook.

For AC power line conducted emissions, the EUT was set to connect with the WLAN AP under large package sizes transmission.

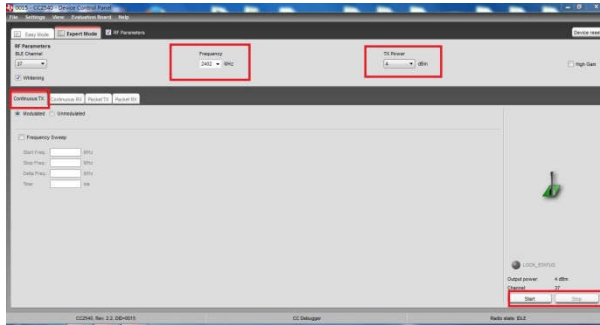

Monitor the SW Version of Cc-debugger



2.6 Measurement Results Explanation Example

For all conducted test items:

The offset level is set in the spectrum analyzer to compensate the RF cable loss between EUT conducted output port and spectrum analyzer. With the offset compensation, the spectrum analyzer reading level is exactly the EUT RF output level.

Example :

The spectrum analyzer offset is derived from RF cable loss.

Offset = RF cable loss.

Following shows an offset computation example with cable loss 5.5 dB.

$$\begin{aligned} \text{Offset(dB)} &= \text{RF cable loss(dB)} . \\ &= 5.5 \text{ (dB)} \end{aligned}$$

3 Test Result

3.1 6dB and 99% Bandwidth Measurement

3.1.1 Limit of 6dB and 99% Bandwidth

The minimum 6 dB bandwidth shall be at least 500 kHz.

3.1.2 Measuring Instruments

The section 4.0 of List of Measuring Equipment of this test report is used for test.

3.1.3 Test Procedures

1. The testing follows FCC KDB Publication No. 558074 D01 DTS Meas. Guidance v03r05.
2. The RF output of EUT was connected to the spectrum analyzer by RF cable and attenuator. The path loss was compensated to the results for each measurement.
3. Set to the maximum power setting and enable the EUT transmit continuously.
4. Make the measurement with the spectrum analyzer's resolution bandwidth (RBW) = 100 kHz. Set the Video bandwidth (VBW) = 300 kHz. In order to make an accurate measurement. The 6 dB bandwidth must be greater than 500 kHz.
5. For 99% Bandwidth Measurement, the spectrum analyzer's resolution bandwidth (RBW) is set 30kHz and set the Video bandwidth (VBW) = 100kHz.
6. Measure and record the results in the test report.

3.1.4 Test Setup

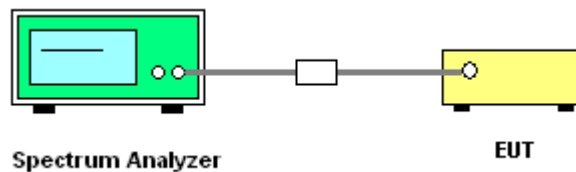



3.1.5 Test Result of 6dB Bandwidth

Test data refer to Appendix A.

6 dB Bandwidth Plot on Channel 00

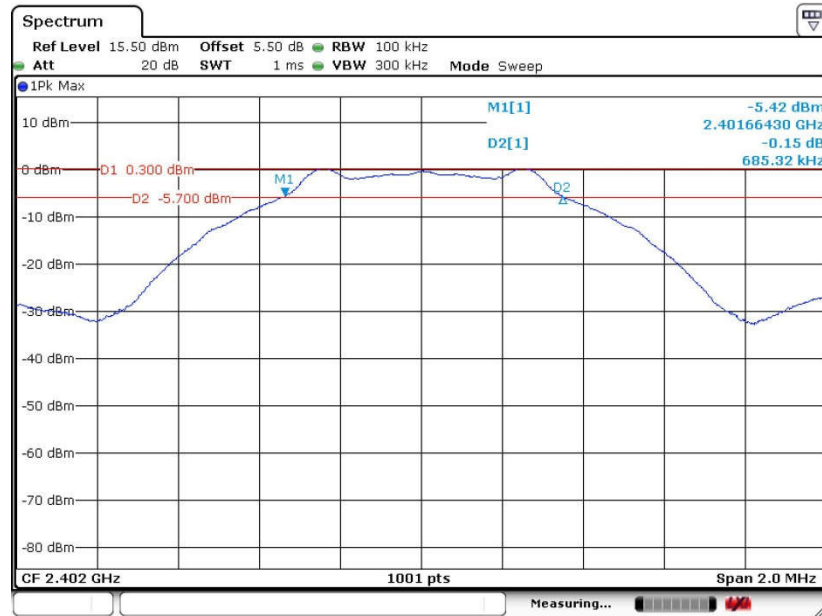

Date: 2.SEP.2016 18:28:32



6 dB Bandwidth Plot on Channel 19



Date: 2.SEP.2016 18:35:48

6 dB Bandwidth Plot on Channel 39

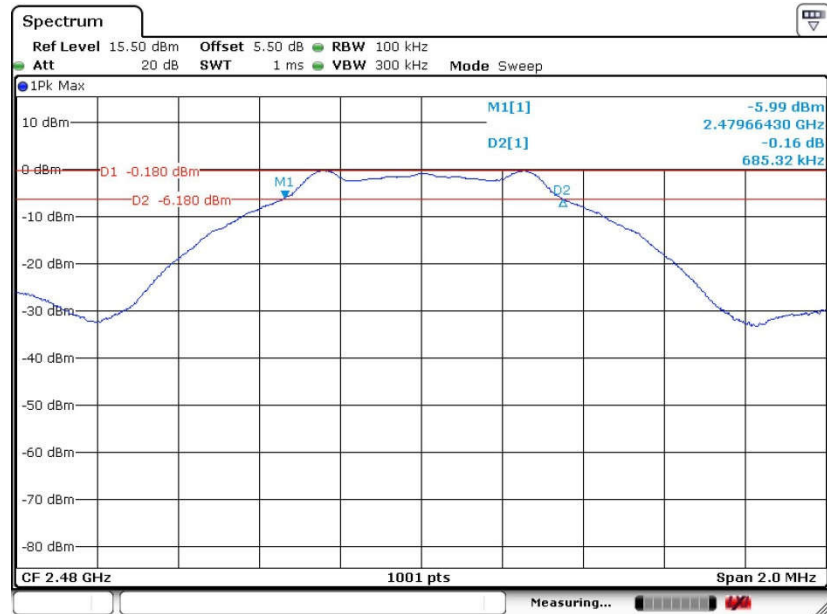

Date: 2.SEP.2016 18:41:02



3.1.6 Test Result of 99% Occupied Bandwidth

Test data refer to Appendix A.

99% Bandwidth Plot on Channel 00

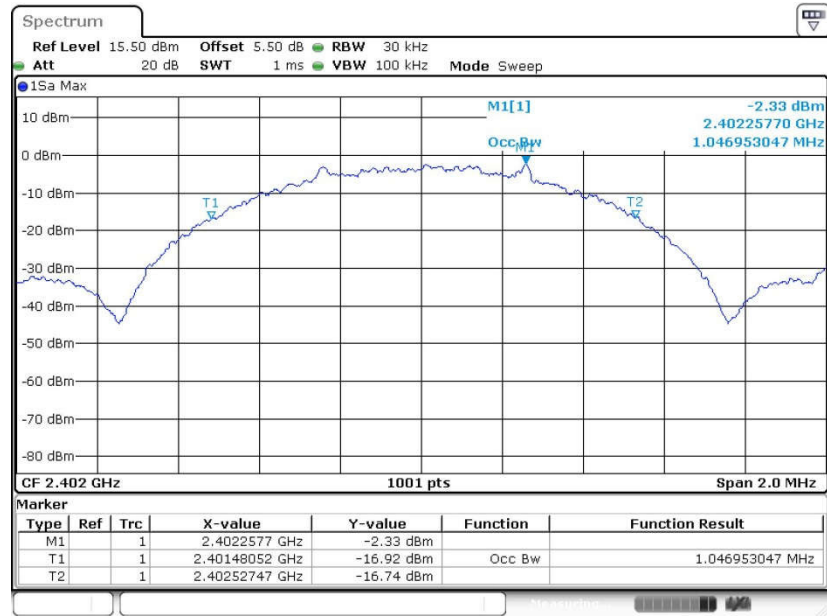

Date: 2.SEP.2016 18:33:34



99% Occupied Bandwidth Plot on Channel 19

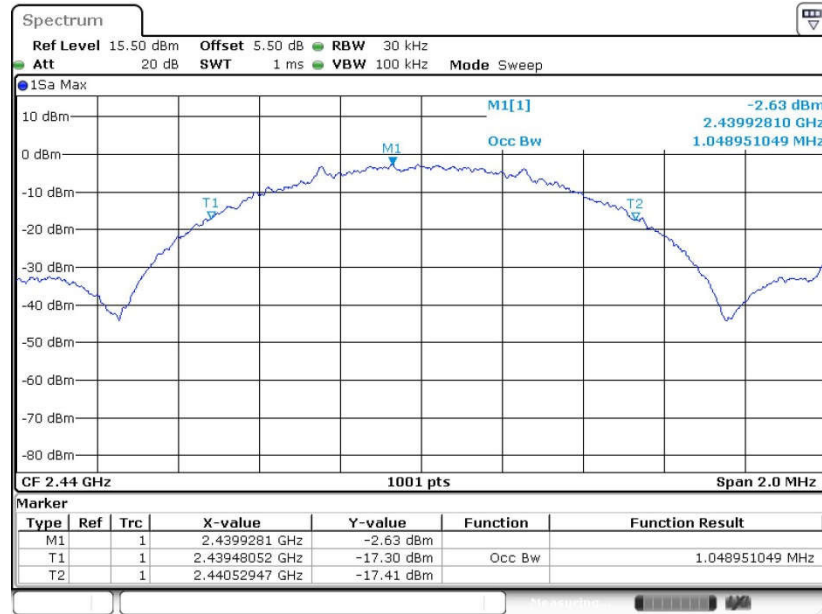

Date: 2.SEP.2016 18:39:08

99% Occupied Bandwidth Plot on Channel 39

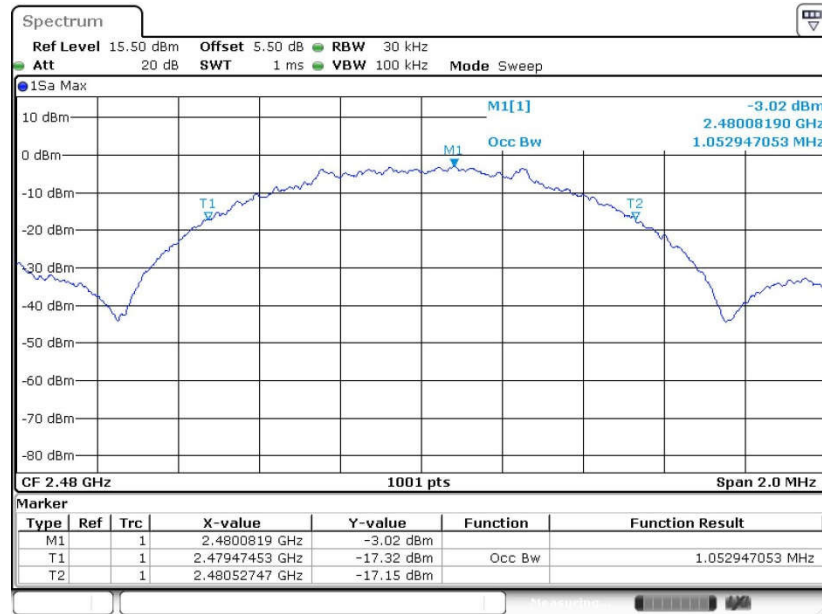

Date: 2.SEP.2016 18:43:39

Note : The occupied channel bandwidth is maintained within the band of operation for all of the modulations.

3.2 Peak Output Power Measurement

3.2.1 Limit of Peak Output Power

For systems using digital modulation in the 2400-2483.5MHz, the limit for peak output power is 30dBm. If transmitting antenna of directional gain greater than 6dBi is used, the peak output power from the intentional radiator shall be reduced below the above stated value by the amount in dB that the directional gain of the antenna exceeds 6 dBi. In case of point-to-point operation, the limit has to be reduced by 1dB for every 3dB that the directional gain of the antenna exceeds 6dBi.

3.2.2 Measuring Instruments

The section 4.0 of List of Measuring Equipment of this test report is used for test.

3.2.3 Test Procedures

1. The testing follows the Measurement Procedure of FCC KDB No. 558074 DTS D01 Meas. Guidance v03r05 section 9.1.2 PKPM1 Peak power meter method.
2. The RF output of EUT was connected to the power meter by RF cable and attenuator. The path loss was compensated to the results for each measurement.
3. Set to the maximum power setting and enable the EUT transmit continuously.
4. Measure the conducted output power and record the results in the test report.

3.2.4 Test Setup

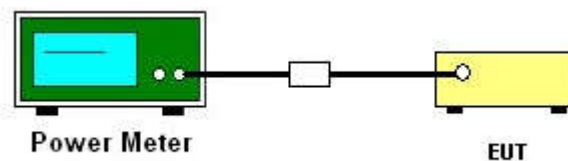

3.2.5 Test Result of Peak Output Power

Test data refers to Appendix A.

3.3 Power Spectral Density Measurement

3.3.1 Limit of Power Spectral Density

The peak power spectral density shall not be greater than 8dBm in any 3kHz band at any time interval of continuous transmission.

3.3.2 Measuring Instruments

The section 4.0 of List of Measuring Equipment of this test report is used for test.

3.3.3 Test Procedures

1. The testing follows Measurement Procedure 10.2 Method PKPSD of FCC KDB Publication No. 558074 D01 DTS Meas. Guidance v03r05
2. The RF output of EUT was connected to the spectrum analyzer by RF cable and attenuator. The path loss was compensated to the results for each measurement.
3. Set to the maximum power setting and enable the EUT transmit continuously.
4. Make the measurement with the spectrum analyzer's resolution bandwidth (RBW) = 3 kHz. Video bandwidth VBW = 10 kHz In order to make an accurate measurement, set the span to 1.5 times DTS Channel Bandwidth. (6dB BW)
5. Detector = peak, Sweep time = auto couple, Trace mode = max hold, Allow trace to fully stabilize. Use the peak marker function to determine the maximum power level.
6. Measure and record the results in the test report.
7. The Measured power density (dBm)/ 100kHz is a reference level and used as 20dBc down limit line for Conducted Band Edges and Conducted Spurious Emission.

3.3.4 Test Setup

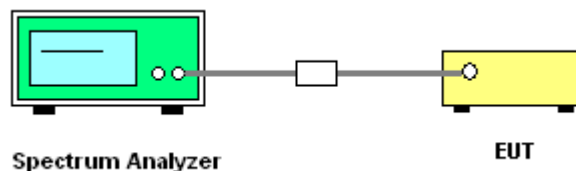



3.3.5 Test Result of Power Spectral Density

Test data refers to Appendix A.

3.3.6 Test Result of Power Spectral Density Plots (100kHz)

PSD 100kHz Plot on Channel 00

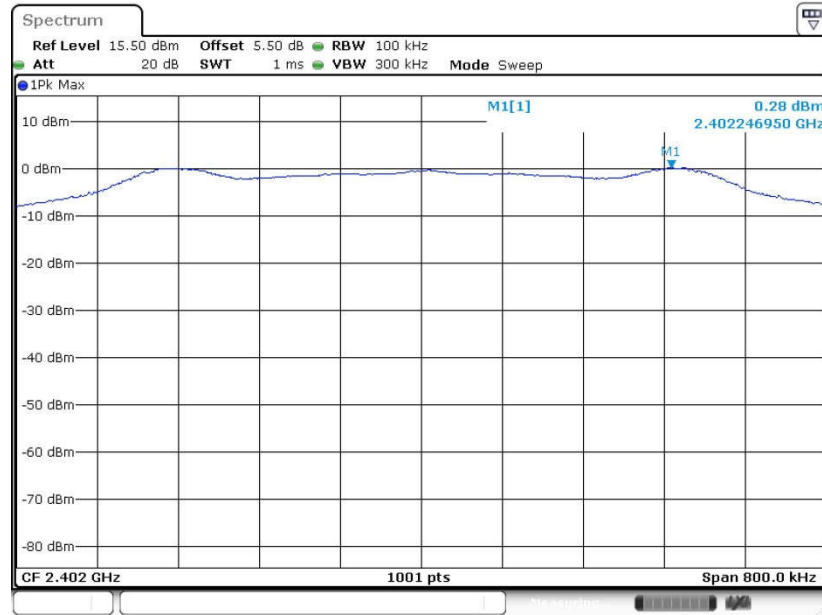



PSD 100kHz Plot on Channel 19

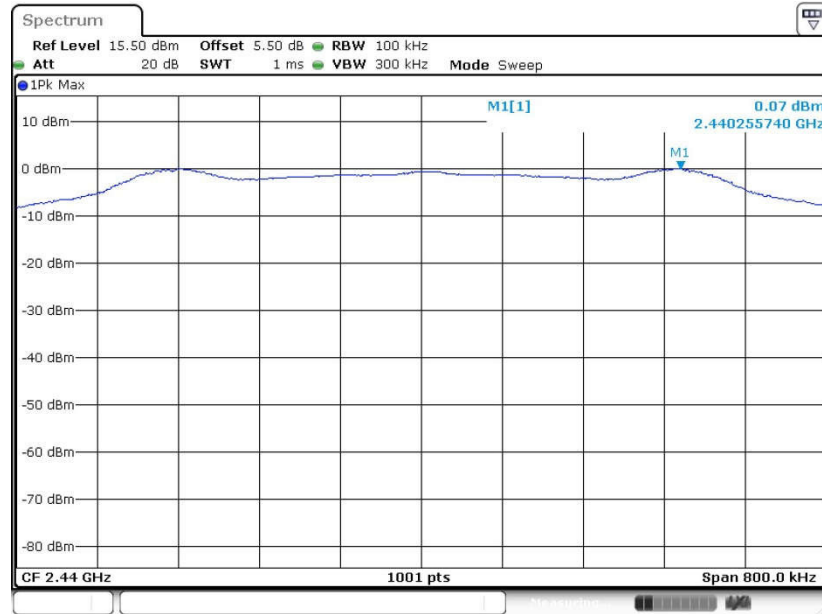

Date: 2.SEP.2016 18:37:23

PSD 100kHz Plot on Channel 39

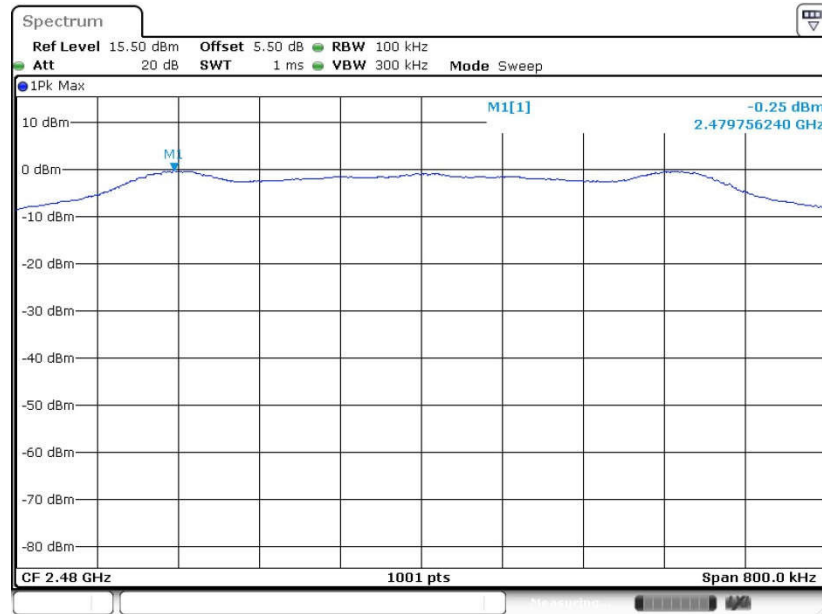

Date: 2.SEP.2016 18:42:47



3.3.7 Test Result of Power Spectral Density Plots (3kHz)

PSD 3kHz Plot on Channel 00

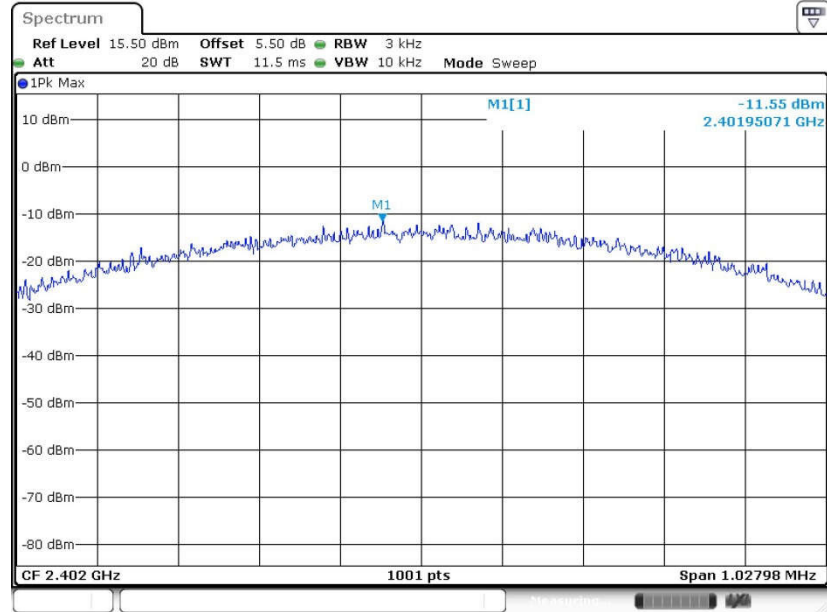

Date: 2.SEP.2016 18:30:11



PSD 3kHz Plot on Channel 19

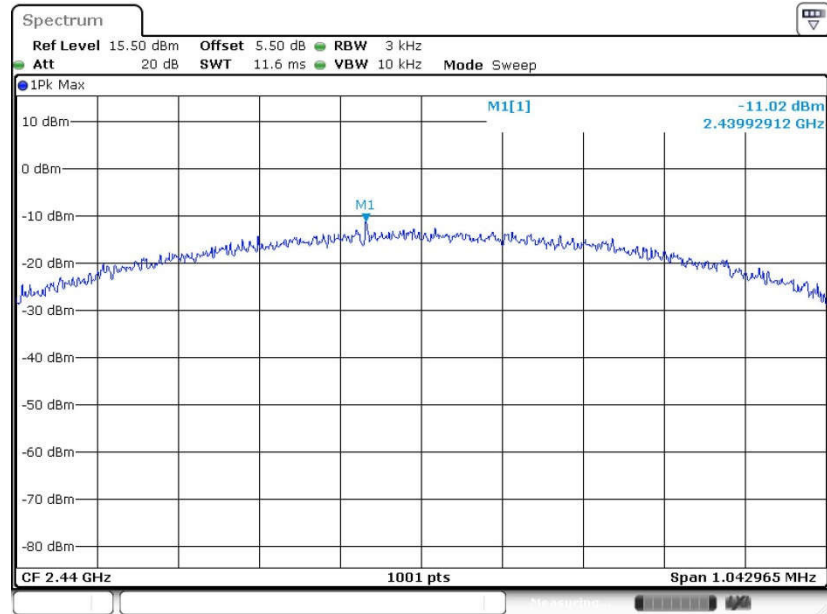

Date: 2.SEP.2016 18:36:52

PSD 3kHz Plot on Channel 39

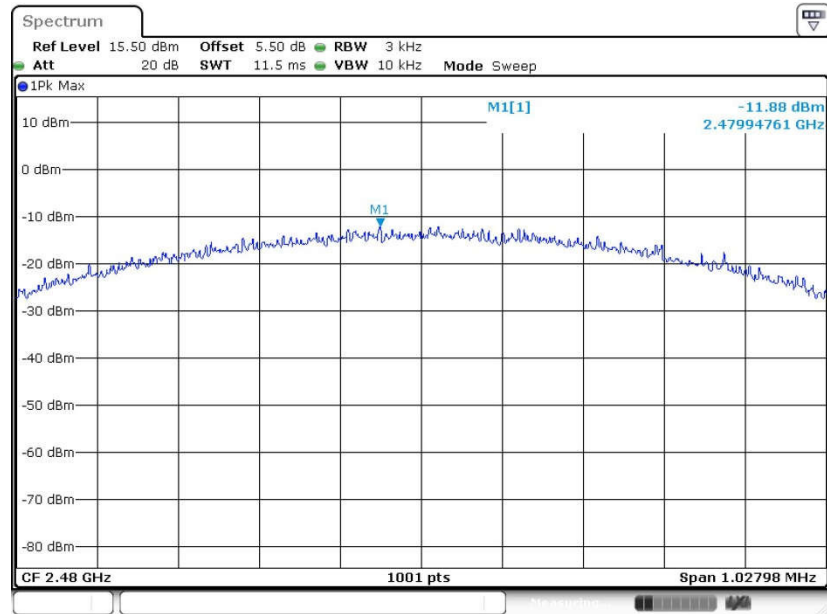

Date: 2.SEP.2016 18:42:22

3.4 Conducted Band Edges and Spurious Emission Measurement

3.4.1 Limit of Conducted Band Edges and Spurious Emission

All harmonics/spurious must be at least 20 dB down from the highest emission level within the authorized band.

3.4.2 Measuring Instruments

The section 4.0 of List of Measuring Equipment of this test report is used for test.

3.4.3 Test Procedure

1. The testing follows FCC KDB Publication No. 558074 D01 DTS Meas. Guidance v03r05.
2. The RF output of EUT was connected to the spectrum analyzer by RF cable and attenuator. The path loss was compensated to the results for each measurement.
3. Set to the maximum power setting and enable the EUT transmit continuously.
4. Set RBW = 100 kHz, VBW=300 kHz, Peak Detector. Unwanted Emissions measured in any 100 kHz bandwidth outside of the authorized frequency band shall be attenuated by at least 20 dB relative to the maximum in-band peak PSD level in 100 kHz when maximum peak conducted output power procedure is used. If the transmitter complies with the conducted power limits based on the use of RMS averaging over a time interval, the attenuation required under this paragraph shall be 30 dB instead of 20 dB per 15.247(d).
5. Measure and record the results in the test report.
6. The RF fundamental frequency should be excluded against the limit line in the operating frequency band.

3.4.4 Test Setup

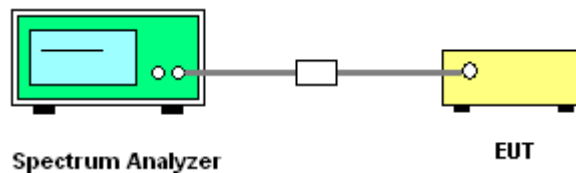



3.4.5 Test Result of Conducted Band Edges Plots

Low Band Edge Plot on Channel 00

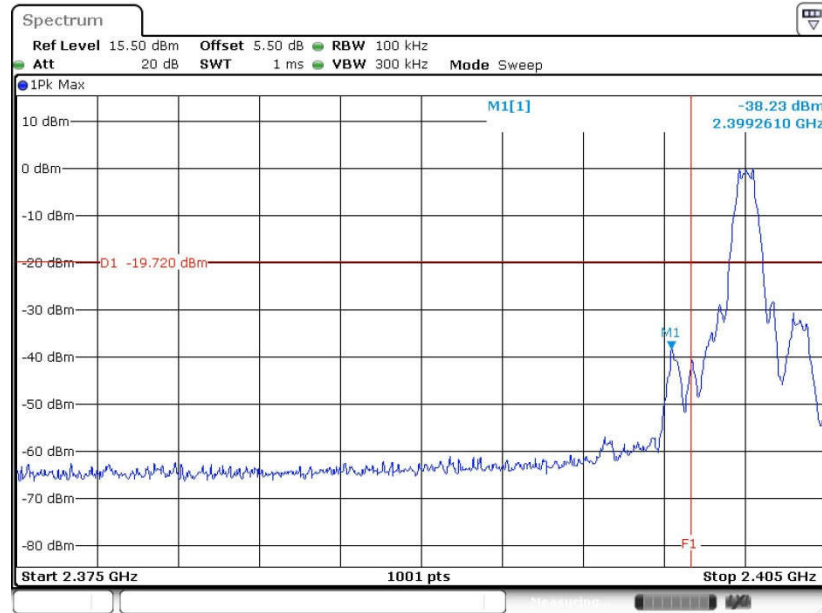

Date: 2.SEP.2016 18:32:23

High Band Edge Plot on Channel 39

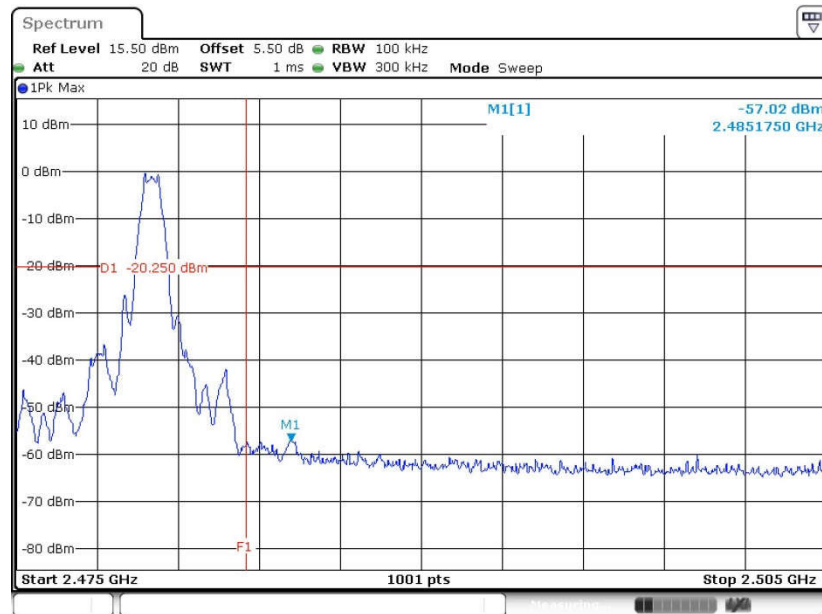

Date: 2.SEP.2016 18:43:04



3.4.6 Test Result of Conducted Spurious Emission Plots

Conducted Spurious Emission Plot on Bluetooth LE 1Mbps GFSK Channel 00

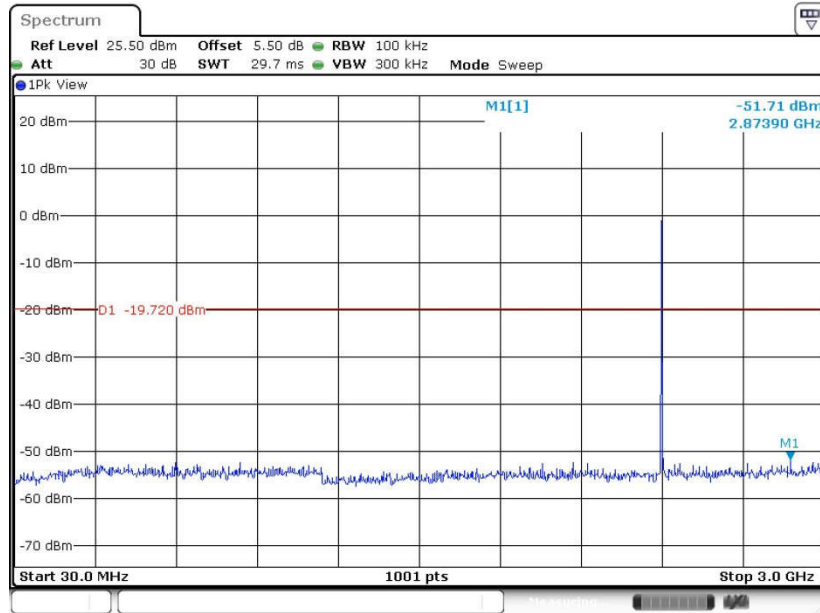

Conducted Spurious Emission Plot on Bluetooth LE 1Mbps GFSK Channel 00

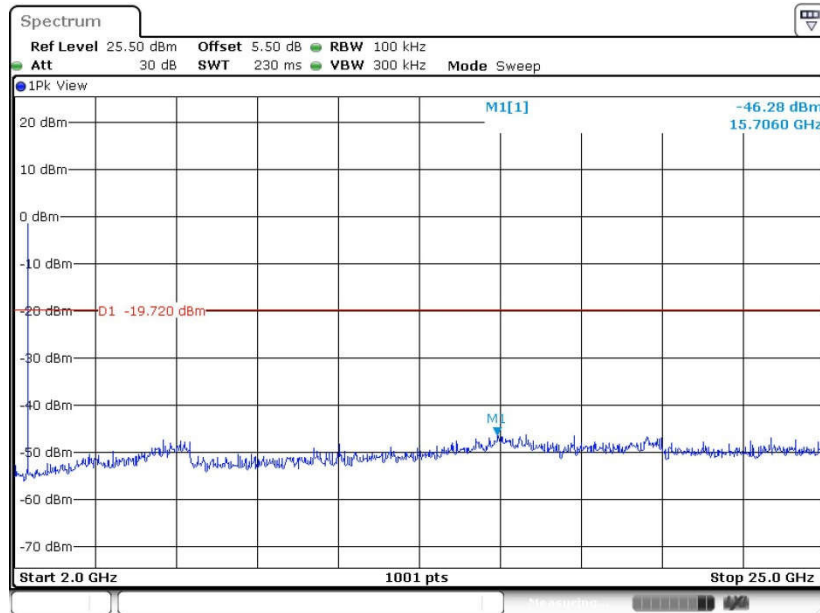



Conducted Spurious Emission Plot on Bluetooth LE 1Mbps GFSK Channel 19

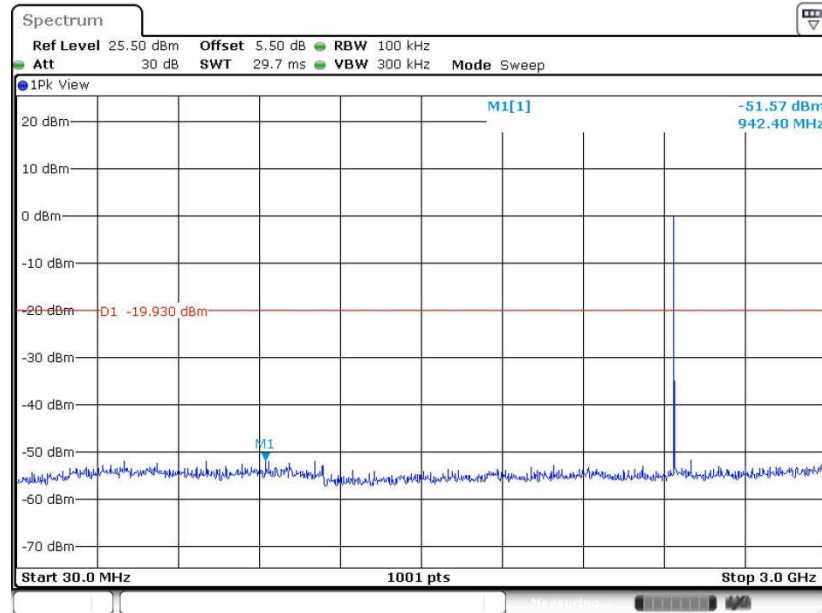

Date: 2.SEP.2016 18:37:36

Conducted Spurious Emission Plot on Bluetooth LE 1Mbps GFSK Channel 19

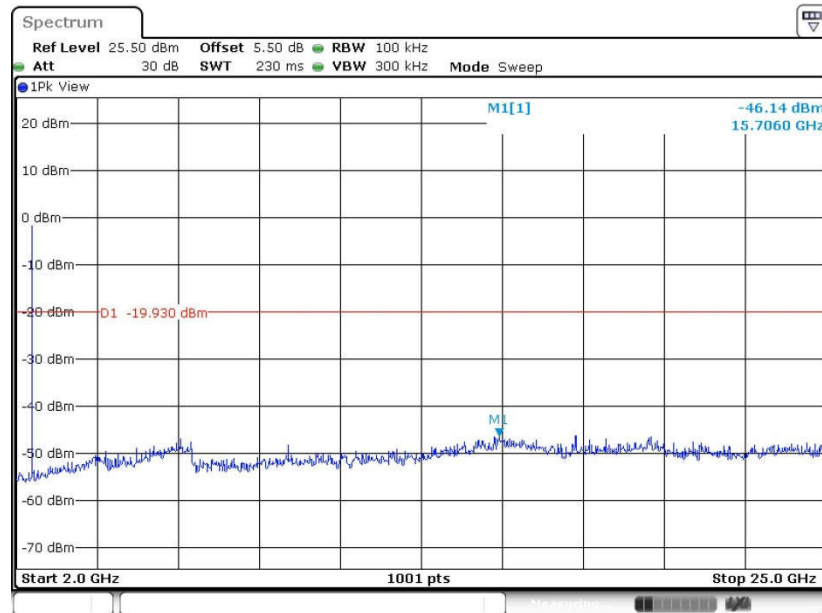

Date: 2.SEP.2016 18:37:45



Conducted Spurious Emission Plot on Bluetooth LE 1Mbps GFSK Channel 39

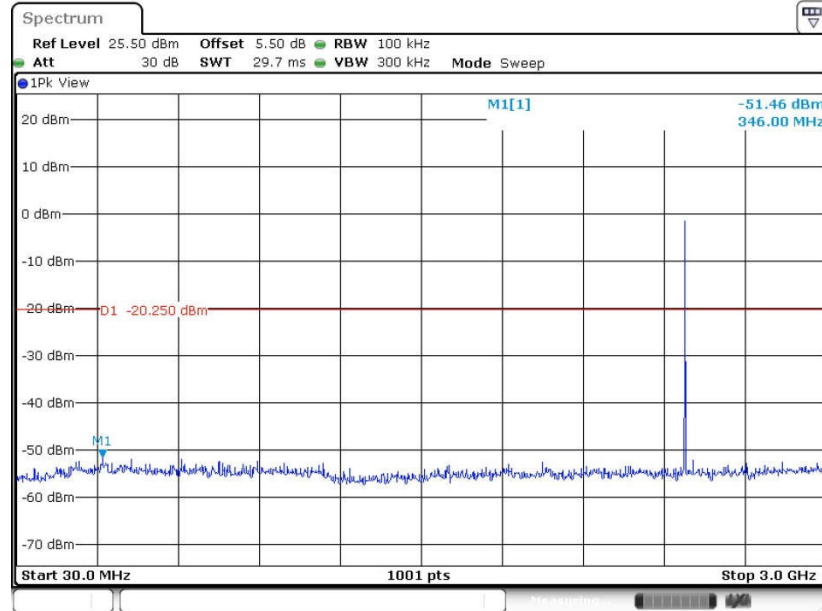

Date: 2.SEP.2016 18:43:15

Conducted Spurious Emission Plot on Bluetooth LE 1Mbps GFSK Channel 39

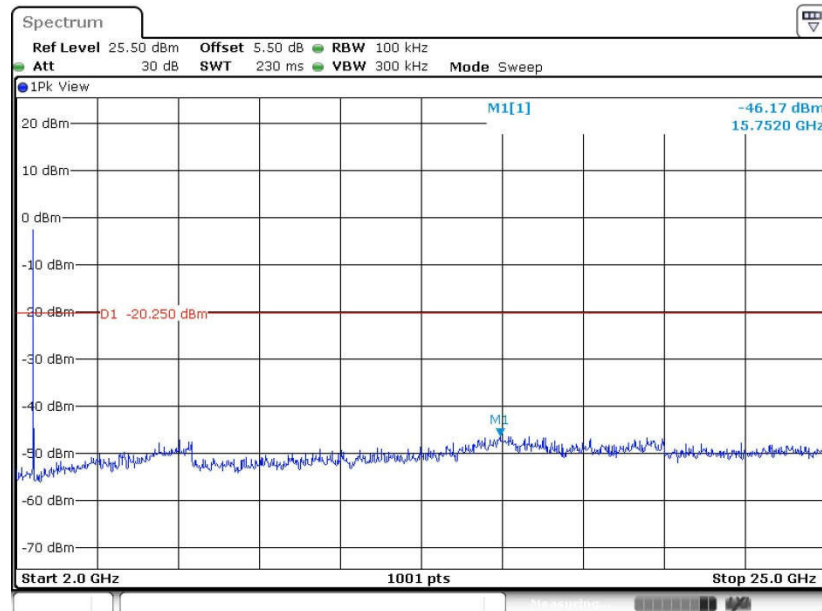

Date: 2.SEP.2016 18:43:24



3.5 Radiated Band Edges and Spurious Emission Measurement

3.5.1 Limit of Radiated Band Edges and Spurious Emission

In any 100 kHz bandwidth outside the intentional radiator frequency band, all harmonics/spurious must be at least 20 dB below the highest emission level within the authorized band. If the output power of this device was measured by spectrum analyzer, the attenuation under this paragraph shall be 30 dB instead of 20 dB. In addition, radiated emissions which fall in the restricted bands must also comply with the FCC section 15.209 limits as below.

Frequency (MHz)	Field Strength (microvolts/meter)	Measurement Distance (meters)
0.009 – 0.490	2400/F(kHz)	300
0.490 – 1.705	24000/F(kHz)	30
1.705 – 30.0	30	30
30 – 88	100	3
88 – 216	150	3
216 - 960	200	3
Above 960	500	3

3.5.2 Measuring Instruments

The section 4.0 of List of Measuring Equipment of this test report is used for test.



3.5.3 Test Procedures

1. The testing follows FCC KDB Publication No. 558074 D01 DTS Meas. Guidance v03r05.
2. The EUT was arranged to its worst case and then tune the antenna tower (from 1 m to 4 m) and turntable (from 0 degree to 360 degrees) to find the maximum reading. A pre-amp and a high pass filter are used for the test in order to get better signal level.
3. The EUT was placed on a turntable with 0.8 meter for frequency below 1GHz and 1.5 meter for frequency above 1GHz respectively above ground.
4. The EUT was set 3 meters from the interference receiving antenna, which was mounted on the top of a variable height antenna tower.
5. Corrected Reading: Antenna Factor + Cable Loss + Read Level - Preamp Factor = Level
6. For measurement below 1GHz, If the emission level of the EUT measured by the peak detector is 3 dB lower than the applicable limit, the peak emission level will be reported. Otherwise, the emission measurement will be repeated using the quasi-peak detector and reported.
7. Use the following spectrum analyzer settings:
 - (1) Span shall wide enough to fully capture the emission being measured;
 - (2) Set RBW=100 kHz for $f < 1$ GHz; VBW \geq RBW; Sweep = auto; Detector function = peak; Trace = max hold;
 - (3) Set RBW = 1 MHz, VBW= 3MHz for $f \geq 1$ GHz for peak measurement.
For average measurement:
 - VBW = 10 Hz, when duty cycle is no less than 98 percent.
 - VBW $\geq 1/T$, when duty cycle is less than 98 percent where T is the minimum transmission duration over which the transmitter is on and is transmitting at its maximum power control level for the tested mode of operation.

3.5.4 Test Setup

For radiated emissions below 30MHz

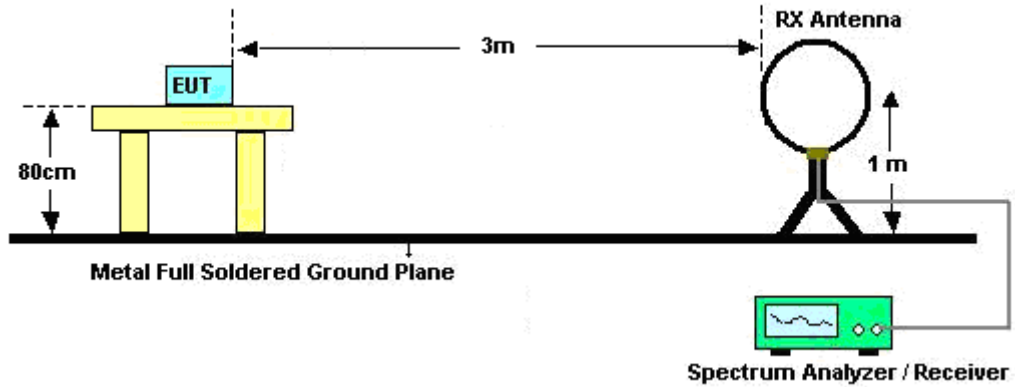

For radiated emissions from 30MHz to 1GHz

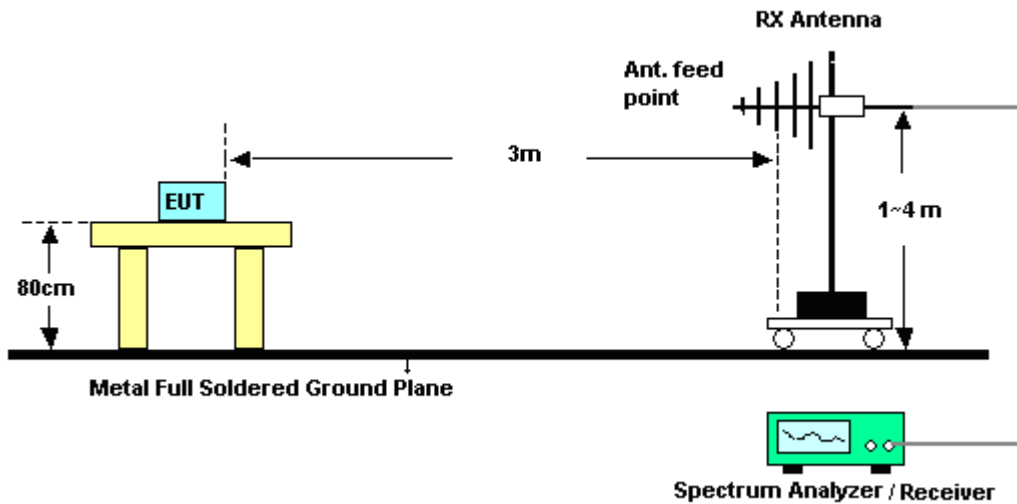

For radiated emissions above 1GHz

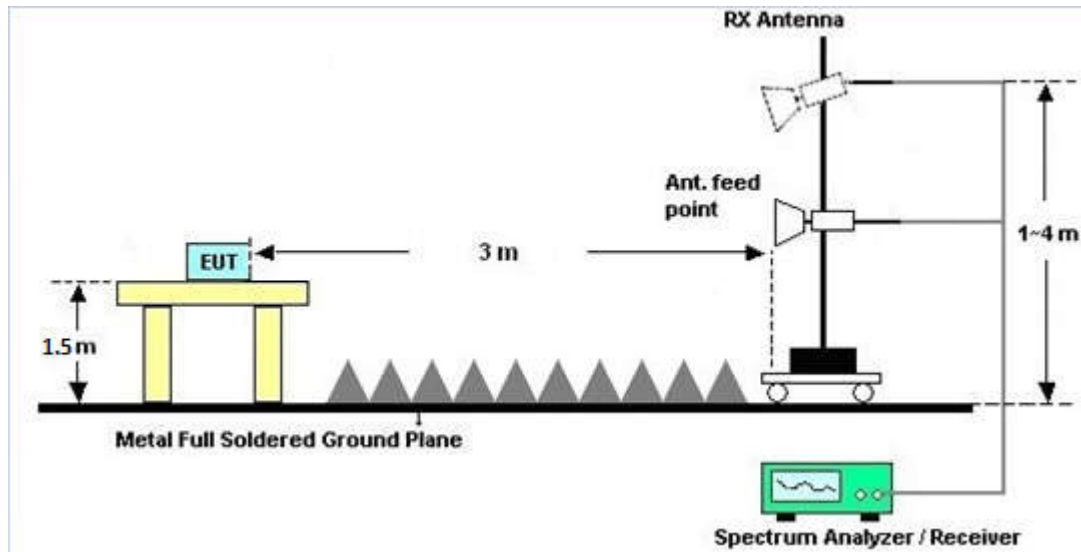

3.5.5 Test Results of Radiated Spurious Emissions (9 kHz ~ 30 MHz)

The low frequency, which started from 9 kHz to 30MHz, was pre-scanned and the result which was 20dB lower than the limit line per 15.31(o) was not reported.

3.5.6 Test Result of Radiated Spurious at Band Edges

Please refer to Appendix B and B.

3.5.7 Duty Cycle

Please refer to Appendix C.

3.5.8 Test Result of Radiated Spurious Emission (30MHz ~ 10th Harmonic)

Please refer to Appendix B.

Remark: Pre-scanned all test modes and only choose the worst case mode recorded in the test report for radiated spurious emission below 1GHz.



3.6 AC Conducted Emission Measurement

3.6.1 Limit of AC Conducted Emission

For equipment that is designed to be connected to the public utility (AC) power line, the radio frequency voltage that is conducted back onto the AC power line on any frequency or frequencies within the band 150 kHz to 30 MHz shall not exceed the limits in the following table.

Frequency of emission (MHz)	Conducted limit (dB μ V)	
	Quasi-peak	Average
0.15-0.5	66 to 56*	56 to 46*
0.5-5	56	46
5-30	60	50

*Decreases with the logarithm of the frequency.

3.6.2 Measuring Instruments

The section 4.0 of List of Measuring Equipment of this test report is used for test.

3.6.3 Test Procedures

1. The EUT was placed 0.4 meter from the conducting wall of the shielding room was kept at least 80 centimeters from any other grounded conducting surface.
2. Connect EUT to the power mains through a line impedance stabilization network (LISN).
3. All the support units are connecting to the other LISN.
4. The LISN provides 50 ohm coupling impedance for the measuring instrument.
5. The FCC states that a 50 ohm, 50 microhenry LISN should be used.
6. Both sides of AC line were checked for maximum conducted interference.
7. The frequency range from 150 kHz to 30 MHz was searched.
8. Set the test-receiver system to Peak Detect Function and specified bandwidth (IF Bandwidth = 9kHz) with Maximum Hold Mode. Then measurement is also conducted by Average Detector and Quasi-Peak Detector Function respectively.

3.6.4 Test Setup

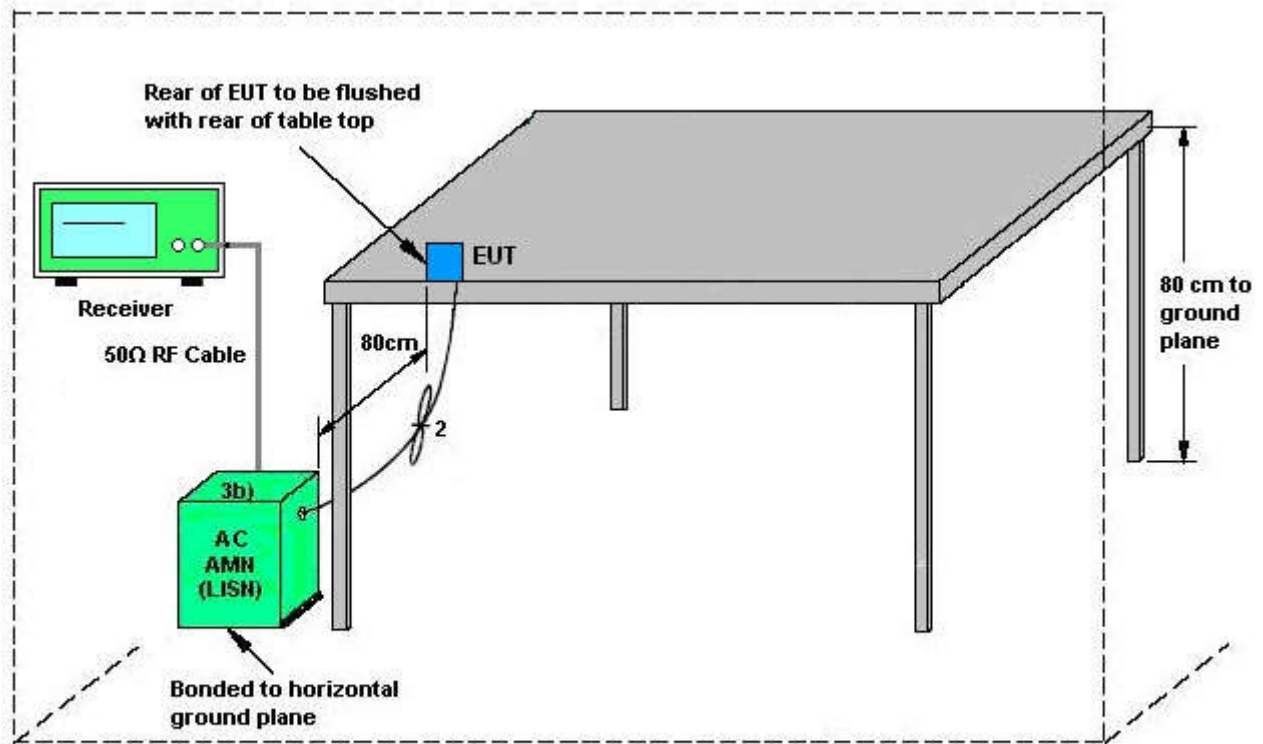

AMN = Artificial mains network (LISN)
AE = Associated equipment
EUT = Equipment under test
ISN = Impedance stabilization network



3.6.5 Test Result of AC Conducted Emission

Test Mode :	Mode 3	Temperature :	22~24°C
Test Engineer :	Morris Li	Relative Humidity :	44~46%
Test Voltage :	120Vac / 60Hz	Phase :	Line
Function Type :	Bluetooth Link + WLAN Link (2.4G) + Adapter for Sample 3		

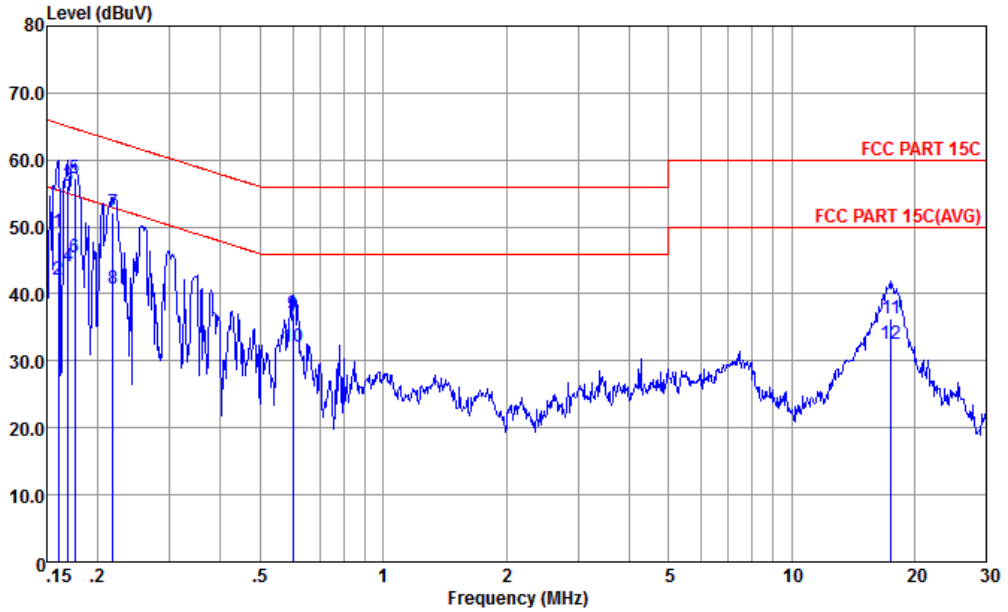

Site : CO01-KS
 Condition : FCC PART 15C LISN-L-20151024 LINE
 mode : Mode 3
 : #14

	Freq	Level	Over Limit	Limit Line	Read Level	LISN Factor	Cable Loss	Remark
	MHz	dBuV	dB	dBuV	dBuV	dB	dB	
1	0.160	49.27	-16.20	65.47	38.70	0.46	10.11	QP
2	0.160	42.07	-13.40	55.47	31.50	0.46	10.11	Average
3	0.169	56.22	-8.77	64.99	45.70	0.40	10.12	QP
4	0.169	44.22	-10.77	54.99	33.70	0.40	10.12	Average
5 *	0.176	57.18	-7.50	64.68	46.70	0.36	10.12	QP
6	0.176	45.38	-9.30	54.68	34.90	0.36	10.12	Average
7	0.217	52.25	-10.67	62.92	41.90	0.22	10.13	QP
8	0.217	40.75	-12.17	52.92	30.40	0.22	10.13	Average
9	0.601	37.09	-18.91	56.00	26.69	0.24	10.16	QP
10	0.601	32.09	-13.91	46.00	21.69	0.24	10.16	Average
11	17.568	36.43	-23.57	60.00	25.70	0.27	10.46	QP
12	17.568	32.43	-17.57	50.00	21.70	0.27	10.46	Average



Test Mode :	Mode 3	Temperature :	22~24°C
Test Engineer :	Morris Li	Relative Humidity :	44~46%
Test Voltage :	120Vac / 60Hz	Phase :	Neutral
Function Type :	Bluetooth Link + WLAN Link (2.4G) + Adapter for Sample 3		

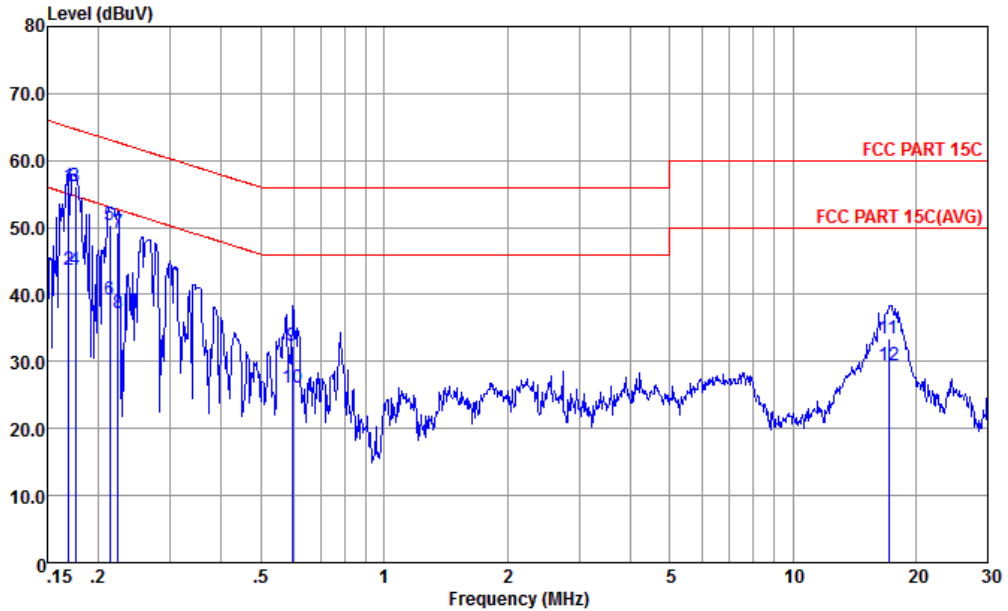

Site : CO01-KS
 Condition : FCC PART 15C LISN-N-20151024 NEUTRAL
 mode : Mode 3
 : #14

	Freq	Level	Over Limit	Limit Line	Read Level	LISN Factor	Cable Loss	Remark
	MHz	dBuV	dB	dBuV	dBuV	dB	dB	
1	0.169	56.12	-8.87	64.99	45.70	0.30	10.12	QP
2	0.169	43.62	-11.37	54.99	33.20	0.30	10.12	Average
3 *	0.176	56.13	-8.55	64.68	45.70	0.31	10.12	QP
4	0.176	43.73	-10.95	54.68	33.30	0.31	10.12	Average
5	0.213	50.34	-12.76	63.10	39.90	0.31	10.13	QP
6	0.213	39.14	-13.96	53.10	28.70	0.31	10.13	Average
7	0.223	49.34	-13.36	62.70	38.90	0.31	10.13	QP
8	0.223	37.14	-15.56	52.70	26.70	0.31	10.13	Average
9	0.595	32.29	-23.71	56.00	21.80	0.33	10.16	QP
10	0.595	26.09	-19.91	46.00	15.60	0.33	10.16	Average
11	17.199	33.41	-26.59	60.00	22.70	0.26	10.45	QP
12	17.199	29.41	-20.59	50.00	18.70	0.26	10.45	Average



3.7 Antenna Requirements

3.7.1 Standard Applicable

If directional gain of transmitting antennas is greater than 6dBi, the power shall be reduced by the same level in dB comparing to gain minus 6dBi. The use of a permanently attached antenna or of an antenna that uses a unique coupling to the intentional radiator shall be considered sufficient to comply with the FCC rule.

3.7.2 Antenna Anti-Replacement Construction

An embedded-in antenna design is used for APIN0305(Mode Name)

Non-standard antenna connector is used for APIN0304(Mode Name)

3.7.3 Antenna Gain

The antenna peak gain of EUT is less than 6 dBi. Therefore, it is not necessary to reduce maximum peak output power limit.



4 List of Measuring Equipment

Instrument	Manufacturer	Model No.	Serial No.	Characteristics	Calibration Date	Test Date	Due Date	Remark
Spectrum Analyzer	R&S	FSV30	101338	10Hz~30GHz	Apr. 22, 2016	Aug. 11, 2016~ Sep. 02, 2016	Apr. 21, 2017	Conducted (TH01-KS)
Spectrum Analyzer	R&S	FSV40	101040	10Hz~40GHz	Aug. 09, 2016	Aug. 11, 2016~ Sep. 02, 2016	Aug. 08, 2017	Conducted (TH01-KS)
Pulse Power Sensor	Anritsu	MA2411B	0917070	300MHz~40GHz	Jan. 20, 2016	Aug. 11, 2016~ Sep. 02, 2016	Jan. 19, 2017	Conducted (TH01-KS)
Power Meter	Anritsu	ML2495A	1005002	50MHz Bandwidth	Jan. 20, 2016	Aug. 11, 2016~ Sep. 02, 2016	Jan. 19, 2017	Conducted (TH01-KS)
EMI Test Receiver	R&S	ESCI	100534	9kHz~3GHz	Oct. 24, 2015	Aug. 11, 2016~ Sep. 05, 2016	Oct. 23, 2016	Radiation (03CH03-KS)
EXA Spectrum Analyzer	Keysight	N9010A	MY551502 44	10Hz~44GHz	Apr. 22, 2016	Aug. 11, 2016~ Sep. 05, 2016	Apr. 21, 2017	Radiation (03CH03-KS)
Loop Antenna	R&S	HFH2-Z2	100321	9kHz~30MHz	Nov. 07, 2015	Aug. 11, 2016~ Sep. 05, 2016	Nov. 06, 2016	Radiation (03CH03-KS)
Bilog Antenna	TeseQ	CBL6112D	35406	25MHz~2GHz	Apr. 16, 2016	Aug. 11, 2016~ Sep. 05, 2016	Apr. 15, 2017	Radiation (03CH03-KS)
Horn Antenna	Schwarzbeck	BBHA9120D	9120D-135 6	1GHz~18GHz	Apr. 16, 2016	Aug. 11, 2016~ Sep. 05, 2016	Apr. 15, 2017	Radiation (03CH03-KS)
SHF-EHF Horn	com-power	AH-840	101070	18GHz~40GHz	Oct. 10, 2015	Aug. 11, 2016~ Sep. 05, 2016	Oct. 09, 2016	Radiation (03CH03-KS)
Amplifier	SONOMA	310N	187289	9kHz~1GHz	Aug. 09, 2016	Aug. 11, 2016~ Sep. 05, 2016	Aug. 08, 2017	Radiation (03CH03-KS)
high gain Amplifier	MITEQ	AMF-7D-0010 1800-30-10P	1943529	1GHz~18GHz	Jan. 20, 2016	Aug. 11, 2016~ Sep. 05, 2016	Jan.19, 2017	Radiation (03CH03-KS)
Amplifier	Agilent	8449B	3008A023 70	1GHz~26.5GHz	Oct. 24, 2015	Aug. 11, 2016~ Sep. 05, 2016	Oct. 23, 2016	Radiation (03CH03-KS)
Amplifier	MITEQ	TTA1840-35- HG	1887435	18GHz~40GHz	Aug. 27, 2015	Aug. 11, 2016~ Sep. 05, 2016	Aug. 26, 2016	Radiation (03CH03-KS)
AC Power Source	Chroma	61601	F1040900 04	N/A	NCR	Aug. 11, 2016~ Sep. 05, 2016	NCR	Radiation (03CH03-KS)
Turn Table	ChamPro	EM 1000-T	060762-T	0~360 degree	NCR	Aug. 11, 2016~ Sep. 05, 2016	NCR	Radiation (03CH03-KS)
Antenna Mast	ChamPro	EM 1000-A	060762-A	1 m~4 m	NCR	Aug. 11, 2016~ Sep. 05, 2016	NCR	Radiation (03CH03-KS)
EMI Receiver	R&S	ESCI7	100768	9kHz~7GHz;	Apr. 29, 2016	Sep. 07, 2016	Apr. 28, 2017	Conduction (CO01-KS)
AC LISN	MessTec	AN3016	060103	9kHz~30MHz	Oct. 24, 2015	Sep. 07, 2016	Oct. 23, 2016	Conduction (CO01-KS)
AC LISN (for auxiliary equipment)	MessTec	AN3016	060105	9kHz~30MHz	Oct. 24, 2015	Sep. 07, 2016	Oct. 23, 2016	Conduction (CO01-KS)
AC Power Source	Chroma	61602	ABP00000 0811	AC 0V~300V, 45Hz~1000Hz	Oct. 24, 2015	Sep. 07, 2016	Oct. 23, 2016	Conduction (CO01-KS)



5 Uncertainty of Evaluation

Uncertainty of Conducted Emission Measurement (150 kHz ~ 30 MHz)

Measuring Uncertainty for a Level of Confidence of 95% ($U = 2Uc(y)$)	2.3dB
---	-------

Uncertainty of Radiated Emission Measurement (30 MHz ~ 1000 MHz)

Measuring Uncertainty for a Level of Confidence of 95% ($U = 2Uc(y)$)	4.5dB
---	-------

Uncertainty of Radiated Emission Measurement (1000 MHz ~ 18000 MHz)

Measuring Uncertainty for a Level of Confidence of 95% ($U = 2Uc(y)$)	4.5dB
---	-------

Uncertainty of Radiated Emission Measurement (18000 MHz ~ 40000 MHz)

Measuring Uncertainty for a Level of Confidence of 95% ($U = 2Uc(y)$)	4.6dB
---	-------



Appendix A. Conducted Test Results

Bluetooth Low Energy

Test Engineer:	Ivan Zhang	Temperature:	24~25	°C
Test Date:	2016/8/11~2016/9/2	Relative Humidity:	54~55	%

TEST RESULTS DATA
6dB and 99% Occupied Bandwidth

Mod.	Data Rate	NTX	CH.	Freq. (MHz)	99% Occupied BW (MHz)	6dB BW (MHz)	6dB BW Limit (MHz)	Pass/Fail
BLE	1Mbps	1	0	2402	1.05	0.69	0.50	Pass
BLE	1Mbps	1	19	2440	1.05	0.70	0.50	Pass
BLE	1Mbps	1	39	2480	1.05	0.69	0.50	Pass

TEST RESULTS DATA
Peak Power Table

Mod.	Data Rate	NTX	CH.	Freq. (MHz)	Peak Conducted Power (dBm)	Conducted Power Limit (dBm)	DG (dBi)	EIRP Power (dBm)	EIRP Power Limit (dBm)	Pass /Fail
BLE	1Mbps	1	0	2402	0.42	30.00	4.50	4.92	36.00	Pass
BLE	1Mbps	1	19	2440	0.17	30.00	4.50	4.67	36.00	Pass
BLE	1Mbps	1	39	2480	-0.12	30.00	4.50	4.38	36.00	Pass

TEST RESULTS DATA
Average Power Table
(Reporting Only)

Mod.	Data Rate	NTX	CH.	Freq. (MHz)	Duty Factor (dB)	Average Conducted Power (dBm)
BLE	1Mbps	1	0	2402	0.00	0.19
BLE	1Mbps	1	19	2440	0.00	-0.11
BLE	1Mbps	1	39	2480	0.00	-0.44

TEST RESULTS DATA
Peak Power Density

Mod.	Data Rate	NTX	CH.	Freq. (MHz)	Peak PSD (dBm /100kHz)	Peak PSD (dBm /3kHz)	DG (dBi)	Peak PSD Limit (dBm /3kHz)	Pass/Fail
BLE	1Mbps	1	0	2402	0.28	-11.55	4.50	8.00	Pass
BLE	1Mbps	1	19	2440	0.07	-11.02	4.50	8.00	Pass
BLE	1Mbps	1	39	2480	-0.25	-11.88	4.50	8.00	Pass

Note: PSD (dBm/ 100kHz) is a reference level used for Conducted Band Edges and Conducted Spurious Emission 20dBc limit.



Appendix B. Radiated Spurious Emission

For Sample 1 with Adapter

2.4GHz 2400~2483.5MHz

BLE (Band Edge @ 3m)

BLE	Note	Frequency	Level	Over Limit	Limit Line	Read Level	Antenna Factor	Cable Loss	Preamp Factor	Ant Pos	Table Pos	Peak Avg.	Pol.
		(MHz)	(dBμV/m)	(dB)	(dBμV/m)	(dBμV)	(dB/m)	(dB)	(dB)	(cm)	(deg)	(P/A)	(H/V)
BLE CH 00 2402MHz		2342.37	51.67	-22.33	74	56.41	26.86	5.41	37.01	195	332	P	H
		2389.82	39.56	-14.44	54	44.11	27	5.47	37.02	195	332	A	H
	*	2402.338	91.61	-	-	96.16	27	5.47	37.02	195	332	P	H
	*	2402.004	91.13	-	-	95.68	27	5.47	37.02	195	332	A	H
		2383.45	51.33	-22.67	74	55.95	26.95	5.45	37.02	192	0	P	V
		2375	40.89	-13.11	54	45.51	26.95	5.45	37.02	192	0	A	V
	*	2401.837	94.92	-	-	99.47	27	5.47	37.02	192	0	P	V
	*	2402.004	94.57	-	-	99.12	27	5.47	37.02	192	0	A	V
BLE CH 19 2440MHz	*	2440.247	92.66	-	-	96.75	27.39	5.49	36.97	183	334	P	H
	*	2439.997	92.2	-	-	96.29	27.39	5.49	36.97	183	334	A	H
	*	2440.08	95.61	-	-	99.7	27.39	5.49	36.97	176	351	P	V
	*	2439.997	95.2	-	-	99.29	27.39	5.49	36.97	176	351	A	V
BLE CH 39 2480MHz	*	2479.742	93.79	-	-	97.58	27.64	5.51	36.94	176	335	P	H
	*	2480.02	93.04	-	-	96.83	27.64	5.51	36.94	176	335	A	H
		2489.98	56.02	-17.98	74	59.66	27.77	5.52	36.93	176	335	P	H
		2483.5	45.98	-8.02	54	49.77	27.64	5.51	36.94	176	335	A	H
	*	2479.742	94.54	-	-	98.33	27.64	5.51	36.94	100	51	P	V
	*	2480.02	93.78	-	-	97.57	27.64	5.51	36.94	100	51	A	V
		2494.78	55.84	-18.16	74	59.48	27.77	5.52	36.93	100	51	P	V
		2483.5	46.28	-7.72	54	50.07	27.64	5.51	36.94	100	51	A	V
Remark	1. No other spurious found. 2. All results are PASS against Peak and Average limit line.												



2.4GHz 2400~2483.5MHz
BLE (Harmonic @ 3m)

BLE	Note	Frequency (MHz)	Level (dBμV/m)	Over Limit (dB)	Limit Line (dBμV/m)	Read Level (dBμV)	Antenna Factor (dB/m)	Cable Loss (dB)	Preamp Factor (dB)	Ant Pos (cm)	Table Pos (deg)	Peak Avg. (P/A)	Pol. (H/V)
BLE CH 00 2402MHz		4806	51.08	-22.92	74	48.58	31.48	7.71	36.69	291	360	P	H
		4806	49.32	-4.68	54	46.82	31.48	7.71	36.69	382	178	A	H
		4806	51.02	-22.98	74	48.52	31.48	7.71	36.69	200	360	P	V
		4806	50.4	-3.60	54	47.9	31.48	7.71	36.69	242	232	A	V
BLE CH 19 2440MHz		4878	52.63	-21.37	74	49.94	31.59	7.76	36.66	300	87	P	H
		4878	52.18	-1.82	54	49.49	31.59	7.76	36.66	277	274	A	H
		7320	46.54	-27.46	74	39.39	34.08	9.78	36.71	300	87	P	H
		4878	53.93	-20.07	74	51.24	31.59	7.76	36.66	254	360	P	V
		4878	52.86	-1.14	54	50.17	31.59	7.76	36.66	260	242	A	V
		7320	45.65	-28.35	74	38.5	34.08	9.78	36.71	254	360	P	V
BLE CH 39 2480MHz		4962	50.77	-23.23	74	47.86	31.72	7.82	36.63	298	360	P	H
		7440	48.45	-25.55	74	40.91	34.44	9.87	36.77	298	360	P	H
		4962	51.24	-22.76	74	48.33	31.72	7.82	36.63	350	0	P	V
		4962	47.81	-6.19	54	44.9	31.72	7.82	36.63	265	221	A	V
		7440	48.76	-25.24	74	41.22	34.44	9.87	36.77	350	0	P	V
Remark	1. No other spurious found. 2. All results are PASS against Peak and Average limit line.												



Emission below 1GHz

2.4GHz BLE (LF)

BLE	Note	Frequency	Level	Over	Limit	Read	Antenna	Cable	Preamp	Ant	Table	Peak	Pol.
		(MHz)	(dBμV/m)	(dB)	(dBμV/m)	(dBμV)	(dB/m)	(dB)	(dB)	(cm)	(deg)	(P/A)	(H/V)
2.4GHz BLE LF		168.71	35.27	-8.23	43.5	52.58	12.65	1.57	31.53	-	-	P	H
		173.56	36.05	-7.45	43.5	53.63	12.34	1.6	31.52	150	250	P	H
		209.45	33.51	-9.99	43.5	52.08	11.18	1.73	31.48	-	-	P	H
		222.06	33.18	-12.82	46	51.11	11.81	1.73	31.47	-	-	P	H
		244.37	30.91	-15.09	46	47.72	12.91	1.73	31.45	-	-	P	H
		279.29	31.04	-14.96	46	46.28	14.2	1.97	31.41	-	-	P	H
		173.56	32.25	-11.25	43.5	49.83	12.34	1.6	31.52	-	-	P	V
		209.45	34.51	-8.99	43.5	53.08	11.18	1.73	31.48	250	150	P	V
		221.09	31.89	-14.11	46	49.87	11.76	1.73	31.47	-	-	P	V
		559.62	34.61	-11.39	46	44.6	18.33	2.96	31.28	-	-	P	V
		627.52	31.99	-14.01	46	41.78	18.46	3.15	31.4	-	-	P	V
		975.75	31.08	-22.92	54	34.02	23.7	4.04	30.68	-	-	P	V

Remark	1. No other spurious found.
	2. All results are PASS against limit line.



For Sample 2 with Adapter

2.4GHz 2400~2483.5MHz

BLE (Band Edge @ 3m)

BLE	Note	Frequency	Level	Over	Limit	Read	Antenna	Cable	Preamp	Ant	Table	Peak	Pol.
		(MHz)	(dBμV/m)	(dB)	(dBμV/m)	(dBμV)	(dB/m)	(dB)	(dB)	(cm)	(deg)	(P/A)	(H/V)
BLE CH 00 2402MHz		2340.03	50.92	-23.08	74	55.66	26.86	5.41	37.01	376	39	P	H
		2375	39.6	-14.40	54	44.22	26.95	5.45	37.02	376	39	A	H
	*	2402.254	91.99	-	-	96.54	27	5.47	37.02	376	39	P	H
	*	2402.004	91.53	-	-	96.08	27	5.47	37.02	376	39	A	H
		2341.85	51.39	-22.61	74	56.13	26.86	5.41	37.01	113	49	P	V
		2374.87	39.59	-14.41	54	44.21	26.95	5.45	37.02	113	49	A	V
	*	2401.837	89.34	-	-	93.89	27	5.47	37.02	113	49	P	V
	*	2402.004	88.96	-	-	93.51	27	5.47	37.02	113	49	A	V
BLE CH 19 2440MHz	*	2439.997	93.9	-	-	97.99	27.39	5.49	36.97	378	54	P	H
	*	2439.997	94	-	-	98.09	27.39	5.49	36.97	378	54	A	H
	*	2439.997	94.43	-	-	98.52	27.39	5.49	36.97	400	90	P	V
	*	2439.997	94.5	-	-	98.59	27.39	5.49	36.97	400	90	A	V
BLE CH 39 2480MHz	*	2479.826	98.37	-	-	102.16	27.64	5.51	36.94	400	54	P	H
	*	2480.02	97.6	-	-	101.39	27.64	5.51	36.94	400	54	A	H
		2483.5	55.37	-18.63	74	59.16	27.64	5.51	36.94	400	54	P	H
		2483.5	51.63	-2.37	54	55.42	27.64	5.51	36.94	400	54	A	H
	*	2480.243	95.44	-	-	99.23	27.64	5.51	36.94	400	52	P	V
	*	2480.02	94.68	-	-	98.47	27.64	5.51	36.94	400	52	A	V
		2483.5	54.66	-19.34	74	58.45	27.64	5.51	36.94	400	52	P	V
		2483.5	49.17	-4.83	54	52.96	27.64	5.51	36.94	400	52	A	V
Remark	1. No other spurious found. 2. All results are PASS against Peak and Average limit line.												



**2.4GHz 2400~2483.5MHz
BLE (Harmonic @ 3m)**

BLE	Note	Frequency (MHz)	Level (dBμV/m)	Over Limit (dB)	Limit Line (dBμV/m)	Read Level (dBμV)	Antenna Factor (dB/m)	Cable Loss (dB)	Preamp Factor (dB)	Ant Pos (cm)	Table Pos (deg)	Peak Avg. (P/A)	Pol. (H/V)
BLE CH 00 2402MHz		4806	51.15	-22.85	74	48.65	31.48	7.71	36.69	100	0	P	H
		4806	46.15	-7.85	54	43.65	31.48	7.71	36.69	311	116	A	H
		4806	48.29	-25.71	74	45.79	31.48	7.71	36.69	300	360	P	V
BLE CH 19 2440MHz		4878	48.02	-25.98	74	45.33	31.59	7.76	36.66	100	121	P	H
		7320	45.14	-28.86	74	37.99	34.08	9.78	36.71	100	360	P	H
		4878	49.81	-24.19	74	47.12	31.59	7.76	36.66	235	270	P	V
		7320	46.15	-27.85	74	39	34.08	9.78	36.71	100	360	P	V
BLE CH 39 2480MHz		4962	52.22	-21.78	74	49.31	31.72	7.82	36.63	100	360	P	H
		4962	51.51	-2.49	54	48.6	31.72	7.82	36.63	269	196	A	H
		7440	45.16	-28.84	74	37.62	34.44	9.87	36.77	100	360	P	H
		4962	47.28	-26.72	74	44.37	31.72	7.82	36.63	100	360	P	V
		7440	46.56	-27.44	74	39.02	34.44	9.87	36.77	100	360	P	V
Remark	1. No other spurious found. 2. All results are PASS against Peak and Average limit line.												



For Sample 3 with Adapter

2.4GHz 2400~2483.5MHz

BLE (Band Edge @ 3m)

BLE	Note	Frequency	Level	Over	Limit	Read	Antenna	Cable	Preamp	Ant	Table	Peak	Pol.
				Limit	Line	Level	Factor	Loss	Factor	Pos	Pos	Avg.	
		(MHz)	(dBμV/m)	(dB)	(dBμV/m)	(dBμV)	(dB/m)	(dB)	(dB)	(cm)	(deg)	(P/A)	(H/V)
BLE CH 00 2402MHz		2380.98	50.55	-23.45	74	55.17	26.95	5.45	37.02	367	219	P	H
		2389.69	39.68	-14.32	54	44.23	27	5.47	37.02	367	219	A	H
	*	2402.338	99.67	-	-	104.22	27	5.47	37.02	367	219	P	H
	*	2402.004	99.25	-	-	103.8	27	5.47	37.02	367	219	A	H
		2383.58	50.96	-23.04	74	55.58	26.95	5.45	37.02	302	145	P	V
		2389.95	39.48	-14.52	54	44.03	27	5.47	37.02	302	145	A	V
	*	2402.338	95.89	-	-	100.44	27	5.47	37.02	302	145	P	V
	*	2402.004	95.51	-	-	100.06	27	5.47	37.02	302	145	A	V
BLE CH 19 2440MHz	*	2440.331	99.16	-	-	103.25	27.39	5.49	36.97	400	223	P	H
	*	2439.997	98.8	-	-	102.89	27.39	5.49	36.97	400	223	A	H
	*	2439.746	93.94	-	-	98.03	27.39	5.49	36.97	300	203	P	V
	*	2439.997	93.57	-	-	97.66	27.39	5.49	36.97	300	203	A	V
BLE CH 39 2480MHz	*	2479.742	99.94	-	-	103.73	27.64	5.51	36.94	389	224	P	H
	*	2479.993	99.18	-	-	102.97	27.64	5.51	36.94	389	224	A	H
		2483.52	55.79	-18.21	74	59.58	27.64	5.51	36.94	389	224	P	H
		2483.52	49.99	-4.01	54	53.78	27.64	5.51	36.94	389	224	A	H
	*	2480.243	95.53	-	-	99.32	27.64	5.51	36.94	289	233	P	V
	*	2479.993	94.8	-	-	98.59	27.64	5.51	36.94	289	233	A	V
		2483.52	51.89	-22.11	74	55.68	27.64	5.51	36.94	289	233	P	V
		2483.52	46.13	-7.87	54	49.92	27.64	5.51	36.94	289	233	A	V
Remark	1. No other spurious found. 2. All results are PASS against Peak and Average limit line.												



2.4GHz 2400~2483.5MHz
BLE (Harmonic @ 3m)

BLE	Note	Frequency (MHz)	Level (dBµV/m)	Over Limit (dB)	Limit Line (dBµV/m)	Read Level (dBµV)	Antenna Factor (dB/m)	Cable Loss (dB)	Preamp Factor (dB)	Ant Pos (cm)	Table Pos (deg)	Peak Avg. (P/A)	Pol. (H/V)
BLE CH 00 2402MHz		4806	36.58	-37.42	74	58.65	31.48	5.91	59.46	100	360	P	H
		4806	36.15	-37.85	74	58.22	31.48	5.91	59.46	100	360	P	V
BLE CH 19 2440MHz		4878	38.6	-35.40	74	60.62	31.59	5.53	59.14	100	360	P	H
		7320	38.28	-35.72	74	53.73	34.08	9.11	58.64	100	360	P	H
		4878	38.15	-35.85	74	60.17	31.59	5.53	59.14	100	360	P	V
		7320	38.28	-35.72	74	53.73	34.08	9.11	58.64	100	360	P	V
BLE CH 39 2480MHz		4962	36.55	-37.45	74	58.51	31.72	5.06	58.74	100	360	P	H
		7440	39.82	-34.18	74	55.3	34.44	9.32	59.24	100	360	P	H
		4962	35.97	-38.03	74	57.93	31.72	5.06	58.74	100	360	P	V
		7440	40.58	-33.42	74	56.06	34.44	9.32	59.24	100	360	P	V
Remark	1. No other spurious found. 2. All results are PASS against Peak and Average limit line.												



For Sample 1 with POE Adapter

2.4GHz 2400~2483.5MHz

BLE (Band Edge @ 3m)

BLE	Note	Frequency	Level	Over	Limit	Read	Antenna	Cable	Preamp	Ant	Table	Peak	Pol.
		(MHz)	(dBμV/m)	Limit	Line	Level	Factor	Loss	Factor	Pos	Pos	Avg.	
				(dB)	(dBμV/m)	(dBμV)	(dB/m)	(dB)	(dB)	(cm)	(deg)	(P/A)	(H/V)
BLE CH 19 2440MHz	*	2440.331	95.87	-	-	99.96	27.39	5.49	36.97	312	38	P	H
	*	2439.997	95.49	-	-	99.58	27.39	5.49	36.97	312	38	A	H
	*	2440.247	95.63	-	-	99.72	27.39	5.49	36.97	145	70	P	V
	*	2439.997	95.2	-	-	99.29	27.39	5.49	36.97	145	70	A	V

2.4GHz 2400~2483.5MHz

BLE (Harmonic @ 3m)

BLE	Note	Frequency	Level	Over	Limit	Read	Antenna	Cable	Preamp	Ant	Table	Peak	Pol.
		(MHz)	(dBμV/m)	Limit	Line	Level	Factor	Loss	Factor	Pos	Pos	Avg.	
				(dB)	(dBμV/m)	(dBμV)	(dB/m)	(dB)	(dB)	(cm)	(deg)	(P/A)	(H/V)
BLE CH 19 2440MHz		4878	51	-23	74	48.31	31.59	7.76	36.66	344	328	P	H
		4878	48.12	-5.88	54	45.43	31.59	7.76	36.66	344	328	A	H
		7320	45.82	-28.18	74	38.67	34.08	9.78	36.71	300	360	P	H
		4878	48.43	-25.57	74	45.74	31.59	7.76	36.66	100	0	P	V
		7320	45.92	-28.08	74	38.77	34.08	9.78	36.71	100	0	A	V
Remark	1. No other spurious found. 2. All results are PASS against Peak and Average limit line.												



Note symbol

*	Fundamental Frequency which can be ignored. However, the level of any unwanted emissions shall not exceed the level of the fundamental frequency.
!	Test result is over limit line.
P/A	Peak or Average
H/V	Horizontal or Vertical



A calculation example for radiated spurious emission is shown as below:

WIFI	Note	Frequency	Level	Over	Limit	Read	Antenna	Cable	Preamp	Ant	Table	Peak	Pol.
Ant.				Limit	Line	Level	Factor	Loss	Factor	Pos	Pos	Avg.	
1+2		(MHz)	(dBμV/m)	(dB)	(dBμV/m)	(dBμV)	(dB/m)	(dB)	(dB)	(cm)	(deg)	(P/A)	(H/V)
802.11b		2390	55.45	-18.55	74	54.51	32.22	4.58	35.86	103	308	P	H
CH 01													
2412MHz		2390	43.54	-10.46	54	42.6	32.22	4.58	35.86	103	308	A	H

- 1. Level(dBμV/m) =
Antenna Factor(dB/m) + Cable Loss(dB) + Read Level(dBμV) - Preamp Factor(dB)
- 2. Over Limit(dB) = Level(dBμV/m) – Limit Line(dBμV/m)

For Peak Limit @ 2390MHz:

- 1. Level(dBμV/m)
= Antenna Factor(dB/m) + Cable Loss(dB) + Read Level(dBμV) - Preamp Factor(dB)
= 32.22(dB/m) + 4.58(dB) + 54.51(dBμV) – 35.86 (dB)
= 55.45 (dBμV/m)
- 2. Over Limit(dB)
= Level(dBμV/m) – Limit Line(dBμV/m)
= 55.45(dBμV/m) – 74(dBμV/m)
= -18.55(dB)

For Average Limit @ 2390MHz:

- 1. Level(dBμV/m)
= Antenna Factor(dB/m) + Cable Loss(dB) + Read Level(dBμV) - Preamp Factor(dB)
= 32.22(dB/m) + 4.58(dB) + 42.6(dBμV) – 35.86 (dB)
= 43.54 (dBμV/m)
- 2. Over Limit(dB)
= Level(dBμV/m) – Limit Line(dBμV/m)
= 43.54(dBμV/m) – 54(dBμV/m)
= -10.46(dB)

Both peak and average measured complies with the limit line, so test result is “PASS”.



Appendix C. Radiated Spurious Emission

For Sample 1 with Adapter

2.4GHz 2400~2483.5MHz

BLE (Band Edge @ 3m)

BLE	2.4GHz 2400~2483.5MHz Band Edge @ 3m	
ANT	BLE CH00 2402MHz	
1	Horizontal	Fundamental
Peak	<p>Site Condition : 83CH03-KS : FCC PART 15C 3m HF ANT-2015813-91280 HORIZONTAL : RM:1000.000kHz VSW:3000.000kHz SMT:Auto</p>	<p>Site Condition : 83CH03-KS : FCC PART 15C 3m HF ANT-2015813-91280 HORIZONTAL : RM:1000.000kHz VSW:3000.000kHz SMT:Auto</p>
Avg.	<p>Site Condition : 83CH03-KS : FCC PART 15C (AVG) 3m HF ANT-2015813-91280 HORIZONTAL : RM:1000.000kHz VSW:0.818kHz SMT:Auto</p>	<p>Site Condition : 83CH03-KS : FCC PART 15C (AVG) 3m HF ANT-2015813-91280 HORIZONTAL : RM:1000.000kHz VSW:0.818kHz SMT:Auto</p>



BLE	2.4GHz 2400~2483.5MHz Band Edge @ 3m	
ANT	BLE CH00 2402MHZ	
1	Vertical	Fundamental
Peak	<p>Site Condition : 03CH03-KS : FCC PART 15C 3m HF ANT-2015813-91280 VERTICAL : RBW:1000.000kHz VBW:3000.000kHz SMT:Auto</p>	<p>Site Condition : 03CH03-KS : FCC PART 15C 3m HF ANT-2015813-91280 VERTICAL : RBW:1000.000kHz VBW:3000.000kHz SMT:Auto</p>
Avg	<p>Site Condition : 03CH03-KS : FCC PART 15C (AVG) 3m HF ANT-2015813-91280 VERTICAL : RBW:1000.000kHz VBW:0.010kHz SMT:Auto</p>	<p>Site Condition : 03CH03-KS : FCC PART 15C (AVG) 3m HF ANT-2015813-91280 VERTICAL : RBW:1000.000kHz VBW:0.010kHz SMT:Auto</p>



BLE	2.4GHz 2400~2483.5MHz Fundamental @ 3m	
ANT	BLE CH19 2440MHz	
1	Horizontal	Vertical
Peak	<p>Site Condition : 83CWB3-KS : FCC PART 15C 3m HF ANT-2015813-91200 HORIZONTAL : RBW:1000.000kHz VBW:3000.000kHz SMT:Auto</p>	<p>Site Condition : 83CWB3-KS : FCC PART 15C 3m HF ANT-2015813-91200 VERTICAL : RBW:1000.000kHz VBW:3000.000kHz SMT:Auto</p>
Avg.	<p>Site Condition : 83CWB3-KS : FCC PART 15C (AVG) 3m HF ANT-2015813-91200 HORIZONTAL : RBW:1000.000kHz VBW:0.010kHz SMT:Auto</p>	<p>Site Condition : 83CWB3-KS : FCC PART 15C (AVG) 3m HF ANT-2015813-91200 VERTICAL : RBW:1000.000kHz VBW:0.010kHz SMT:Auto</p>



BLE	2.4GHz 2400~2483.5MHz Band Edge @ 3m	
ANT	BLE CH39 2480MHz	
1	Horizontal	Fundamental
Peak	<p>Site : 83CH03-KS Condition : FCC PART 15C 3m HF ANT-2015813-91200 HORIZONTAL RBW:1000.000kHz VBW:3000.000kHz SMT:Auto</p>	<p>Site : 83CH03-KS Condition : FCC PART 15C 3m HF ANT-2015813-91200 HORIZONTAL RBW:1000.000kHz VBW:3000.000kHz SMT:Auto</p>
Avg.	<p>Site : 83CH03-KS Condition : FCC PART 15C (AVG) 3m HF ANT-2015813-91200 HORIZONTAL RBW:1000.000kHz VBW:0.010kHz SMT:Auto</p>	<p>Site : 83CH03-KS Condition : FCC PART 15C (AVG) 3m HF ANT-2015813-91200 HORIZONTAL RBW:1000.000kHz VBW:0.010kHz SMT:Auto</p>



BLE	2.4GHz 2400~2483.5MHz Band Edge @ 3m	
ANT	BLE CH39 2480MHz	
1	Vertical	Fundamental
Peak	<p>Site : 83CH03-KS Condition : FCC PART 15C 3m HF ANT-2015813-91200 VERTICAL : RBW:1000.000kHz VBW:3000.000kHz SMT:Auto</p>	<p>Site : 83CH03-KS Condition : FCC PART 15C 3m HF ANT-2015813-91200 VERTICAL : RBW:1000.000kHz VBW:3000.000kHz SMT:Auto</p>
Avg.	<p>Site : 83CH03-KS Condition : FCC PART 15C (AVG) 3m HF ANT-2015813-91200 VERTICAL : RBW:1000.000kHz VBW:0.818kHz SMT:Auto</p>	<p>Site : 83CH03-KS Condition : FCC PART 15C (AVG) 3m HF ANT-2015813-91200 VERTICAL : RBW:1000.000kHz VBW:0.818kHz SMT:Auto</p>



2.4GHz 2400~2483.5MHz
BLE (Harmonic @ 3m)

BLE	2.4GHz 2400~2483.5MHz Harmonic @ 3m	
ANT	BLE CH00 2402MHz	
1	Horizontal	Vertical
Peak Avg.	<p>Site : 03CH03-K5 Condition : FCC PART 15C 3m HF ANT-2015813-91200 HORIZONTAL : RBW:1000.000kHz VBW:3000.000kHz SMT:Auto</p>	<p>Site : 03CH03-K5 Condition : FCC PART 15C 3m HF ANT-2015813-91200 VERTICAL : RBW:1000.000kHz VBW:3000.000kHz SMT:Auto</p>

BLE	2.4GHz 2400~2483.5MHz Harmonic @ 3m	
ANT	BLE CH19 2440MHz	
1	Horizontal	Vertical
Peak Avg.	<p>Site : 03CH03-K5 Condition : FCC PART 15C 3m HF ANT-2015813-91200 HORIZONTAL : RBW:1000.000kHz VBW:3000.000kHz SMT:Auto</p>	<p>Site : 03CH03-K5 Condition : FCC PART 15C 3m HF ANT-2015813-91200 VERTICAL : RBW:1000.000kHz VBW:3000.000kHz SMT:Auto</p>



BLE	2.4GHz 2400~2483.5MHz Harmonic @ 3m	
ANT	BLE CH39 2480MHz	
1	Horizontal	Vertical
Peak	<p>Site : 83CWB3-KS Condition : FCC PART 15C 3m HF ANT-2015013-91200 HORIZONTAL : RBW:1000.000kHz VBW:3000.000kHz SMT:Auto</p>	<p>Site : 83CWB3-KS Condition : FCC PART 15C 3m HF ANT-2015013-91200 VERTICAL : RBW:1000.000kHz VBW:3000.000kHz SMT:Auto</p>

Emission below 1GHz
2.4GHz BLE (LF)

BLE	2.4GHz 2400~2483.5MHz	
ANT	BLE LF	
1	Horizontal	Vertical
QP / Peak	<p>Site : 83CWB3-KS Condition : FCC PART 15C 3m LF ANT (NEW) HORIZONTAL : RBW:100.000kHz VBW:300.000kHz SMT:Auto</p>	<p>Site : 83CWB3-KS Condition : FCC PART 15C 3m LF ANT (NEW) VERTICAL : RBW:100.000kHz VBW:300.000kHz SMT:Auto</p>



For Sample 2 with Adapter

2.4GHz 2400~2483.5MHz

BLE (Band Edge @ 3m)

BLE	2.4GHz 2400~2483.5MHz Band Edge @ 3m	
ANT	BLE CH00 2402MHz	
1	Horizontal	Fundamental
Peak	<p>Site : 03CH03-KS Condition : FCC PART 15C 3m HF ANT-2015813-91280 HORIZONTAL : RBW:1000.000kHz VBW:3000.000kHz SMT:Auto</p>	<p>Site : 03CH03-KS Condition : FCC PART 15C 3m HF ANT-2015813-91280 HORIZONTAL : RBW:1000.000kHz VBW:3000.000kHz SMT:Auto</p>
Avg.	<p>Site : 03CH03-KS Condition : FCC PART 15C (AVG) 3m HF ANT-2015813-91280 HORIZONTAL : RBW:1000.000kHz VBW:0.018kHz SMT:Auto</p>	<p>Site : 03CH03-KS Condition : FCC PART 15C (AVG) 3m HF ANT-2015813-91280 HORIZONTAL : RBW:1000.000kHz VBW:0.018kHz SMT:Auto</p>



BLE	2.4GHz 2400~2483.5MHz Band Edge @ 3m	
ANT	BLE CH00 2402MHz	
1	Vertical	Fundamental
Peak	<p>Site : 03CH03-KS Condition : FCC PART 15C 3m HF ANT-2015813-91280 VERTICAL RBW:1000.000kHz VBW:3000.000kHz SMT:Auto</p>	<p>Site : 03CH03-KS Condition : FCC PART 15C 3m HF ANT-2015813-91280 VERTICAL RBW:1000.000kHz VBW:3000.000kHz SMT:Auto</p>
Avg	<p>Site : 03CH03-KS Condition : FCC PART 15C (AVG) 3m HF ANT-2015813-91280 VERTICAL RBW:1000.000kHz VBW:0.010kHz SMT:Auto</p>	<p>Site : 03CH03-KS Condition : FCC PART 15C (AVG) 3m HF ANT-2015813-91280 VERTICAL RBW:1000.000kHz VBW:0.010kHz SMT:Auto</p>



BLE	2.4GHz 2400~2483.5MHz Fundamental @ 3m	
ANT	BLE CH19 2440MHz	
1	Horizontal	Vertical
Peak	<p>Site Condition : 03CH03-K5 : FCC PART 15C 3m HF ANT-2015813-91200 HORIZONTAL : RBW:1000.000kHz VBW:3000.000kHz SMT:Auto</p>	<p>Site Condition : 03CH03-K5 : FCC PART 15C 3m HF ANT-2015813-91200 VERTICAL : RBW:1000.000kHz VBW:3000.000kHz SMT:Auto</p>
Avg.	<p>Site Condition : 03CH03-K5 : FCC PART 15C (AVG) 3m HF ANT-2015813-91200 HORIZONTAL : RBW:1000.000kHz VBW:0.0100kHz SMT:Auto</p>	<p>Site Condition : 03CH03-K5 : FCC PART 15C (AVG) 3m HF ANT-2015813-91200 VERTICAL : RBW:1000.000kHz VBW:0.0100kHz SMT:Auto</p>



BLE	2.4GHz 2400~2483.5MHz Band Edge @ 3m	
ANT	BLE CH39 2480MHz	
1	Horizontal	Fundamental
Peak	<p>Site : 83CHB3-KS Condition : FCC PART 15C 3m HF ANT-2815813-91280 HORIZONTAL : RBW:1000.000kHz VBW:3000.000kHz SMT:Auto</p>	<p>Site : 83CHB3-KS Condition : FCC PART 15C 3m HF ANT-2815813-91280 HORIZONTAL : RBW:1000.000kHz VBW:3000.000kHz SMT:Auto</p>
Avg.	<p>Site : 83CHB3-KS Condition : FCC PART 15C (AVG) 3m HF ANT-2815813-91280 HORIZONTAL : RBW:1000.000kHz VBW:0.018kHz SMT:Auto</p>	<p>Site : 83CHB3-KS Condition : FCC PART 15C (AVG) 3m HF ANT-2815813-91280 HORIZONTAL : RBW:1000.000kHz VBW:0.018kHz SMT:Auto</p>



BLE	2.4GHz 2400~2483.5MHz Band Edge @ 3m	
ANT	BLE CH39 2480MHz	
1	Vertical	Fundamental
Peak	<p>Site : 83CH83-KS Condition : FCC PART 15C 3m HF ANT-2015813-91280 VERTICAL : RBW:1000.000KHz VBW:3000.000KHz SMT:Auto</p>	<p>Site : 83CH83-KS Condition : FCC PART 15C 3m HF ANT-2015813-91280 VERTICAL : RBW:1000.000KHz VBW:3000.000KHz SMT:Auto</p>
Avg.	<p>Site : 83CH83-KS Condition : FCC PART 15C (AVG) 3m HF ANT-2015813-91280 VERTICAL : RBW:1000.000KHz VBW:8.018KHz SMT:Auto</p>	<p>Site : 83CH83-KS Condition : FCC PART 15C (AVG) 3m HF ANT-2015813-91280 VERTICAL : RBW:1000.000KHz VBW:8.018KHz SMT:Auto</p>



2.4GHz 2400~2483.5MHz
BLE (Harmonic @ 3m)

BLE	2.4GHz 2400~2483.5MHz Harmonic @ 3m	
ANT	BLE CH00 2402MHz	
1	Horizontal	Vertical
Peak Avg.	<p>Site Condition : 03CH03-KS : FCC PART 15C 3m HF ANT-2015813-91200 HORIZONTAL : RBW:1000.000KHz VBW:3000.000KHz SMT:Auto</p>	<p>Site Condition : 03CH03-KS : FCC PART 15C 3m HF ANT-2015813-91200 VERTICAL : RBW:1000.000KHz VBW:3000.000KHz SMT:Auto</p>

BLE	2.4GHz 2400~2483.5MHz Harmonic @ 3m	
ANT	BLE CH19 2440MHz	
1	Horizontal	Vertical
Peak Avg.	<p>Site Condition : 03CH03-KS : FCC PART 15C 3m HF ANT-2015813-91200 HORIZONTAL : RBW:1000.000KHz VBW:3000.000KHz SMT:Auto</p>	<p>Site Condition : 03CH03-KS : FCC PART 15C 3m HF ANT-2015813-91200 VERTICAL : RBW:1000.000KHz VBW:3000.000KHz SMT:Auto</p>

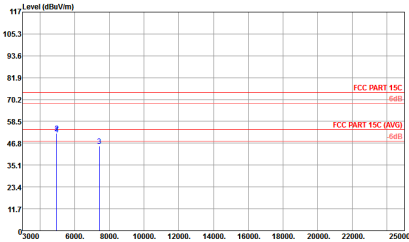
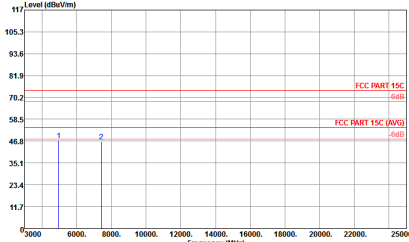

BLE	2.4GHz 2400~2483.5MHz Harmonic @ 3m	
ANT	BLE CH39 2480MHz	
1	Horizontal	Vertical
Peak	 <p>Site Condition : 03CH03-K5 : FCC PART 15C 3m HF ANT-20150113-01200 HORIZONTAL : RBW:1000.000kHz VBW:3000.000kHz SMT:Auto</p>	 <p>Site Condition : 03CH03-K5 : FCC PART 15C 3m HF ANT-20150113-01200 VERTICAL : RBW:1000.000kHz VBW:3000.000kHz SMT:Auto</p>



For Sample 3 with Adapter

2.4GHz 2400~2483.5MHz

BLE (Band Edge @ 3m)

BLE	2.4GHz 2400~2483.5MHz Band Edge @ 3m	
ANT	BLE CH00 2402MHz	
1	Horizontal	Fundamental
Peak	<p>Site Condition : 03CH03-K5 : FCC PART 15C 3m HF ANT-2015813-91280 HORIZONTAL : RBW:1000.000kHz; VBI:0.030kHz; SMT:Auto</p>	<p>Site Condition : 03CH03-K5 : FCC PART 15C 3m HF ANT-2015813-91280 HORIZONTAL : RBW:1000.000kHz; VBI:0.030kHz; SMT:Auto</p>
Avg.	<p>Site Condition : 03CH03-K5 : FCC PART 15C (AVG) 3m HF ANT-2015813-91280 HORIZONTAL : RBW:1000.000kHz; VBI:0.030kHz; SMT:Auto</p>	<p>Site Condition : 03CH03-K5 : FCC PART 15C (AVG) 3m HF ANT-2015813-91280 HORIZONTAL : RBW:1000.000kHz; VBI:0.030kHz; SMT:Auto</p>



BLE	2.4GHz 2400~2483.5MHz Band Edge @ 3m	
ANT	BLE CH00 2402MHz	
1	Vertical	Fundamental
Peak	<p>Site Condition : 83CH03-K5 : FCC PART 15C 3m HF ANT-2015813-91280 VERTICAL : RBW:1000.000KHz VBW:3000.000KHz SMT:Auto</p>	<p>Site Condition : 83CH03-K5 : FCC PART 15C 3m HF ANT-2015813-91280 VERTICAL : RBW:1000.000KHz VBW:3000.000KHz SMT:Auto</p>
Avg	<p>Site Condition : 83CH03-K5 : FCC PART 15C (AVG) 3m HF ANT-2015813-91280 VERTICAL : RBW:1000.000KHz VBW:0.0180KHz SMT:Auto</p>	<p>Site Condition : 83CH03-K5 : FCC PART 15C (AVG) 3m HF ANT-2015813-91280 VERTICAL : RBW:1000.000KHz VBW:0.0180KHz SMT:Auto</p>

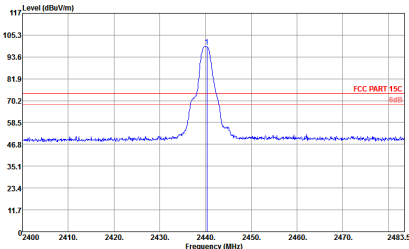
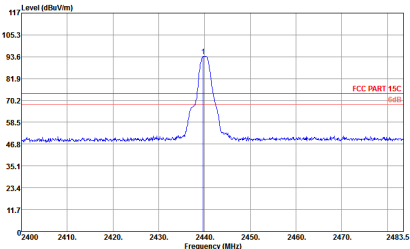
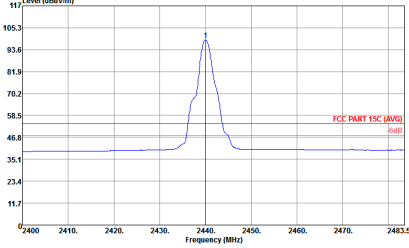
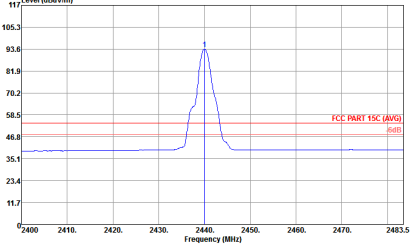

BLE	2.4GHz 2400~2483.5MHz Fundamental @ 3m	
ANT	BLE CH19 2440MHz	
1	Horizontal	Vertical
Peak	 <p>Site : 03CH03-K5 Condition : FCC PART 15C 3m HF ANT-2015813-91200 HORIZONTAL : RBW:1000.000kHz VBW:3000.000kHz SMT:Auto</p>	 <p>Site : 03CH03-K5 Condition : FCC PART 15C 3m HF ANT-2015813-91200 VERTICAL : RBW:1000.000kHz VBW:3000.000kHz SMT:Auto</p>
Avg.	 <p>Site : 03CH03-K5 Condition : FCC PART 15C (AVG) 3m HF ANT-2015813-91200 HORIZONTAL : RBW:1000.000kHz VBW:0.0180kHz SMT:Auto</p>	 <p>Site : 03CH03-K5 Condition : FCC PART 15C (AVG) 3m HF ANT-2015813-91200 VERTICAL : RBW:1000.000kHz VBW:0.0180kHz SMT:Auto</p>



BLE	2.4GHz 2400~2483.5MHz Band Edge @ 3m	
ANT	BLE CH39 2480MHz	
1	Horizontal	Fundamental
Peak	<p>Site : 03CH3-KS Condition : FCC PART 15C 3m HF ANT-2015813-91280 HORIZONTAL RBW:1000.000kHz VBW:3000.000kHz SMT:Auto</p>	<p>Site : 03CH3-KS Condition : FCC PART 15C 3m HF ANT-2015813-91280 HORIZONTAL RBW:1000.000kHz VBW:3000.000kHz SMT:Auto</p>
Avg.	<p>Site : 03CH3-KS Condition : FCC PART 15C (AVG) 3m HF ANT-2015813-91280 HORIZONTAL RBW:1000.000kHz VBW:0.030kHz SMT:Auto</p>	<p>Site : 03CH3-KS Condition : FCC PART 15C (AVG) 3m HF ANT-2015813-91280 HORIZONTAL RBW:1000.000kHz VBW:0.030kHz SMT:Auto</p>



BLE	2.4GHz 2400~2483.5MHz Band Edge @ 3m	
ANT	BLE CH39 2480MHZ	
1	Vertical	Fundamental
Peak	<p>Site Condition : 03CH03-K5 : FCC PART 15C 3m HF ANT-2015813-91200 VERTICAL : RBW:1000.000kHz VBW:3000.000kHz SMT:Auto</p>	<p>Site Condition : 03CH03-K5 : FCC PART 15C 3m HF ANT-2015813-91200 VERTICAL : RBW:1000.000kHz VBW:3000.000kHz SMT:Auto</p>
Avg.	<p>Site Condition : 03CH03-K5 : FCC PART 15C (AVG) 3m HF ANT-2015813-91200 VERTICAL : RBW:1000.000kHz VBW:0.010kHz SMT:Auto</p>	<p>Site Condition : 03CH03-K5 : FCC PART 15C (AVG) 3m HF ANT-2015813-91200 VERTICAL : RBW:1000.000kHz VBW:0.010kHz SMT:Auto</p>



2.4GHz 2400~2483.5MHz
BLE (Harmonic @ 3m)

BLE	2.4GHz 2400~2483.5MHz Harmonic @ 3m	
ANT	BLE CH00 2402MHz	
1	Horizontal	Vertical
Peak Avg.	<p>Site Condition : 83CH03-K5 : FCC PART 15C 3m HF ANT-2015813-91200 HORIZONTAL : RBW:1000.000kHz VBW:3000.000kHz SMT:Auto</p>	<p>Site Condition : 83CH03-K5 : FCC PART 15C 3m HF ANT-2015813-91200 VERTICAL : RBW:1000.000kHz VBW:3000.000kHz SMT:Auto</p>

BLE	2.4GHz 2400~2483.5MHz Harmonic @ 3m	
ANT	BLE CH19 2440MHz	
1	Horizontal	Vertical
Peak Avg.	<p>Site Condition : 83CH03-K5 : FCC PART 15C 3m HF ANT-2015813-91200 HORIZONTAL : RBW:1000.000kHz VBW:3000.000kHz SMT:Auto</p>	<p>Site Condition : 83CH03-K5 : FCC PART 15C 3m HF ANT-2015813-91200 VERTICAL : RBW:1000.000kHz VBW:3000.000kHz SMT:Auto</p>



BLE	2.4GHz 2400~2483.5MHz Harmonic @ 3m	
ANT	BLE CH39 2480MHz	
1	Horizontal	Vertical
Peak	<p>Site Condition : 03CH3-KS : FCC PART 15C 3m HF ANT-2015813-9120 HORIZONTAL : RBW:1000.0000Hz VBW:3000.0000Hz SFT:Auto</p>	<p>Site Condition : 03CH3-KS : FCC PART 15C 3m HF ANT-2015813-9120 VERTICAL : RBW:1000.0000Hz VBW:3000.0000Hz SFT:Auto</p>



For Sample 1 with POE Adapter

2.4GHz 2400~2483.5MHz

BLE (Band Edge @ 3m)

BLE	2.4GHz 2400~2483.5MHz Fundamental @ 3m	
ANT	BLE CH19 2440MHz	
1	Horizontal	Vertical
Peak	<p>Site Condition : 03CH03-KS : FCC PART 15C 3m HF ANT-2015813-91280 HORIZONTAL : RBW:1000.000kHz VBW:3000.000kHz SMT:Auto</p>	<p>Site Condition : 03CH03-KS : FCC PART 15C 3m HF ANT-2015813-91280 VERTICAL : RBW:1000.000kHz VBW:3000.000kHz SMT:Auto</p>
Avg.	<p>Site Condition : 03CH03-KS : FCC PART 15C (AVG) 3m HF ANT-2015813-91280 HORIZONTAL : RBW:1000.000kHz VBW:0.010kHz SMT:Auto</p>	<p>Site Condition : 03CH03-KS : FCC PART 15C (AVG) 3m HF ANT-2015813-91280 VERTICAL : RBW:1000.000kHz VBW:0.010kHz SMT:Auto</p>



2.4GHz 2400~2483.5MHz
BLE (Harmonic @ 3m)

BLE	2.4GHz 2400~2483.5MHz Harmonic @ 3m	
ANT	BLE CH19 2440MHz	
1	Horizontal	Vertical
Peak Avg.	<p>Site Condition : 03CH03-K5 : FCC PART 15C 3m HF ANT-2015813-9120 HORIZONTAL : RES:1000.0000Hz VBW:3000.0000Hz SFT:Auto</p>	<p>Site Condition : 03CH03-K5 : FCC PART 15C 3m HF ANT-2015813-9120 VERTICAL : RES:1000.0000Hz VBW:3000.0000Hz SFT:Auto</p>

Appendix D. Duty Cycle Plots

For Sample 1

Band	Duty Cycle(%)	T(ms)	1/T(kHz)	VBW Setting
Bluetooth v4.0 LE	100.00	-	-	10Hz

Bluetooth v4.0 LE





For Sample 2

Band	Duty Cycle(%)	T(ms)	1/T(kHz)	VBW Setting
Bluetooth v4.0 LE	99.20	-	-	10Hz

Bluetooth v4.0 LE

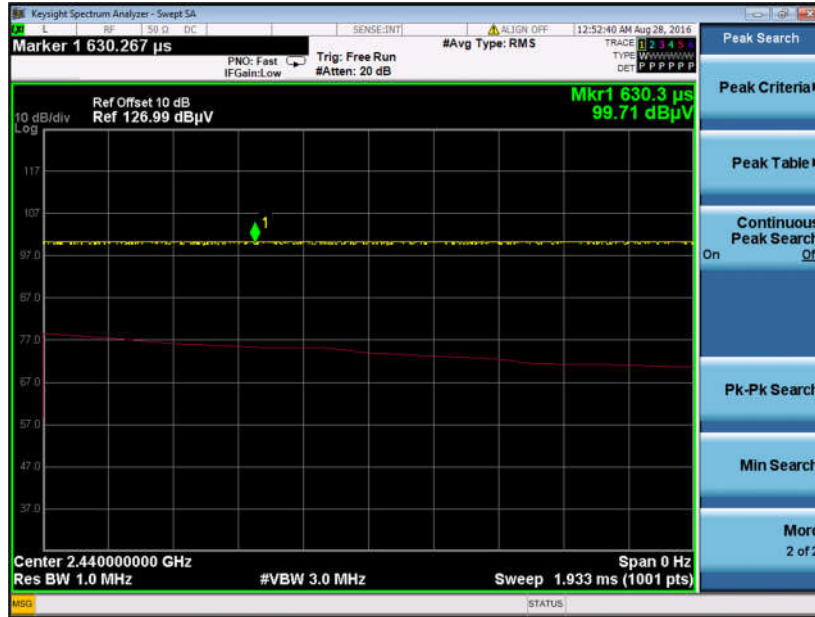



For Sample 3

Band	Duty Cycle(%)	T(ms)	1/T(kHz)	VBW Setting
Bluetooth v4.0 LE	100.00	-	-	10Hz

Bluetooth v4.0 LE

