

Test of APIN0114, APIN0115 802.11a/b/g/n

To: FCC 47 CFR Part 15.407 & IC RSS-210

Test Report Serial No.: ARUB149-U4 Rev A



TEST REPORT

FROM



Test of APIN0114, APIN0115 802.11a/b/g/n

to

To FCC 47 CFR Part 15.407 & IC RSS-210

Test Report Serial No.: ARUB149-U4 Rev A

Note: this report contains data with regard to the 5,250 - 5,350 and 5,470 - 5,7250MHz (DFS) bands for Aruba Networks, APIN0114 and APIN0115 Wireless Access Point. 5,150 - 5,250 MHz (non-DFS) bands are reported in MiCOM Labs report ARUB148-U4 and 2.4 and 5.8 GHz test data are reported in MiCOM Labs test report ARUB148-U4

This report supersedes None

Applicant: Aruba Networks
1344 Crossman Avenue
Sunnyvale, California 94089
USA

Product Function: Wireless Access Point

Copy No: pdf Issue Date: 5th August 2013

This Test Report is Issued Under the Authority of:

MiCOM Labs, Inc.

440 Boulder Court, Suite 200

Pleasanton, CA 94566 USA

Phone: +1 (925) 462-0304

Fax: +1 (925) 462-0306

www.micomlabs.com



TEST CERTIFICATE #2381.01

MiCOM Labs is an ISO 17025 Accredited Testing Laboratory



Title: APIN0114, APIN0115 802.11a/b/g/n
To: FCC 47 CFR Part 15.407 & IC RSS-210
Serial #: ARUB149-U4 Rev A
Issue Date: 5th August 2013
Page: 3 of 257

This page has been left intentionally blank

This test report may be reproduced in full only. The document may only be updated by MiCOM Labs personnel. Any changes will be noted in the Document History section of the report.



TABLE OF CONTENTS

ACCREDITATION, LISTINGS & RECOGNITION	5
TESTING ACCREDITATION	5
RECOGNITION	6
PRODUCT CERTIFICATION	7
1. TEST RESULT CERTIFICATE	9
2. REFERENCES AND MEASUREMENT UNCERTAINTY	10
2.1. Normative References.....	10
2.2. Test and Uncertainty Procedures.....	11
3. PRODUCT DETAILS AND TEST CONFIGURATIONS	12
3.1. Technical Details	12
3.2. Scope of Test Program	13
3.3. Equipment Model(s) and Serial Number(s)	16
3.4. Antenna Details	16
3.5. Cabling and I/O Ports	17
3.6. Test Configurations	18
3.7. Equipment Modifications	19
3.8. Deviations from the Test Standard.....	19
3.9. Subcontracted Testing or Third Party Data	19
4. TESTING EQUIPMENT CONFIGURATION(S)	20
4.1. Conducted RF Emission Test Set-up	20
4.2. Radiated Spurious Emission Test Set-up > 1 GHz	21
4.3. Digital Emissions Test Set-up (0.03 – 1 GHz).....	22
4.4. ac Wireline Emission Test Set-up	23
5. TEST SUMMARY	24
6. TEST RESULTS	27
6.1. Device Characteristics.....	27
6.1.1. <i>Conducted Testing</i>	27
6.1.2. <i>Radiated Emission Testing</i>	53
6.1.3. <i>AC Wireline Conducted Emissions (150 kHz – 30 MHz)</i>	106
7. PHOTOGRAPHS	143
7.1. Test Setup - Digital Emissions below 1 GHz.....	143
7.2. Radiated Emissions Test Setup >1 GHz – ANT-19	145
8. TEST EQUIPMENT DETAILS	147
APPENDIX	148
A. SUPPORTING INFORMATION	148
A.1. CONDUCTED TEST PLOTS	148
A.1.1. <i>26 dB & 99% Bandwidth</i>	149
A.1.2. <i>Peak Power Spectral Density</i>	200
A.1.3. <i>Peak Excursion Ratio</i>	251

This test report may be reproduced in full only. The document may only be updated by MiCOM Labs personnel. Any changes will be noted in the Document History section of the report.

ACCREDITATION, LISTINGS & RECOGNITION

TESTING ACCREDITATION

MiCOM Labs, Inc. is an accredited Electrical testing laboratory per the international standard EN ISO/IEC 17025. The company is accredited by the American Association for Laboratory Accreditation (A2LA) www.a2la.org test laboratory number 2381.01. MiCOM Labs test schedule is available at the following URL; <http://www.a2la.org/scopepdf/2381-01.pdf>



This test report may be reproduced in full only. The document may only be updated by MiCOM Labs personnel. Any changes will be noted in the Document History section of the report.



RECOGNITION

MiCOM Labs, Inc has widely recognized Electrical testing capabilities. Our international recognition includes Conformity Assessment Body designation by APEC MRA** countries. Our test reports are widely accepted for global type approvals.

Country	Recognition Body	Status	Phase	Identification No.
USA	Federal Communications Commission (FCC)	TCB	-	US0159 Listing #: 102167
Canada	Industry Canada (IC)	FCB	APEC MRA 2	US0159 Listing #: 4143A-2
Japan	MIC (Ministry of Internal Affairs and Communication)	CAB	APEC MRA 2	RCB 210
	VCCI	--	--	A-0012
Europe	European Commission	NB	EU MRA	NB 2280
Australia	Australian Communications and Media Authority (ACMA)	CAB	APEC MRA 1	US0159
Hong Kong	Office of the Telecommunication Authority (OFTA)	CAB	APEC MRA 1	
Korea	Ministry of Information and Communication Radio Research Laboratory (RRL)	CAB	APEC MRA 1	
Singapore	Infocomm Development Authority (IDA)	CAB	APEC MRA 1	
Taiwan	National Communications Commission (NCC) Bureau of Standards, Metrology and Inspection (BSMI)	CAB	APEC MRA 1	
Vietnam	Ministry of Communication (MIC)	CAB	APEC MRA 1	

**APEC MRA – Asia Pacific Economic Community Mutual Recognition Agreement.

Is a recognition agreement under which test lab is accredited to regulatory standards of the APEC member countries.

Phase I - recognition for product testing

Phase II – recognition for both product testing and certification

N/A – Not Applicable

**EU MRA – European Union Mutual Recognition Agreement.

Is a recognition agreement under which test lab is accredited to regulatory standards of the EU member countries.

**NB – Notified Body

This test report may be reproduced in full only. The document may only be updated by MiCOM Labs personnel. Any changes will be noted in the Document History section of the report.

PRODUCT CERTIFICATION

MiCOM Labs, Inc. is an accredited Product Certification Body per the international standard EN ISO/IEC Guide 65. The company is accredited by the American Association for Laboratory Accreditation (A2LA) www.a2la.org test laboratory number 2381.02. MiCOM Labs test schedule is available at the following URL; <http://www.a2la.org/scopepdf/2381-02.pdf>



USA Telecommunication Certification Body (TCB) - TCB Identifier – US0159

Industry Canada Certification Body - CAB Identifier – US0159

European Notified Body - Notified Body Identifier - 2280

Japan – Recognized Certification Body (RCB) - RCB Identifier - 210

This test report may be reproduced in full only. The document may only be updated by MiCOM Labs personnel. Any changes will be noted in the Document History section of the report.



Title: APIN0114, APIN0115 802.11a/b/g/n
To: FCC 47 CFR Part 15.407 & IC RSS-210
Serial #: ARUB149-U4 Rev A
Issue Date: 5th August 2013
Page: 8 of 257

DOCUMENT HISTORY

Document History		
Revision	Date	Comments
Draft		
Rev A	5 th August 2013	Initial release

This test report may be reproduced in full only. The document may only be updated by MiCOM Labs personnel. Any changes will be noted in the Document History section of the report.



Title: APIN0114, APIN0115 802.11a/b/g/n
To: FCC 47 CFR Part 15.407 & IC RSS-210
Serial #: ARUB149-U4 Rev A
Issue Date: 5th August 2013
Page: 9 of 257

1. TEST RESULT CERTIFICATE

Applicant:	Aruba Networks 1344 Crossman Avenue Sunnyvale, California 94089 USA	Tested By:	MiCOM Labs, Inc. 440 Boulder Court Suite 200 Pleasanton California, 94566, USA
EUT:	Wireless LAN Access point	Tel:	+1 925 462 0304
Model:	APIN0114 & APIN0115	Fax:	+1 925 462 0306
S/N:	Engineering Sample		
Test Date(s):	10th - 31st July 2013	Website:	www.micomlabs.com

STANDARD(S)	TEST RESULTS
FCC 47 CFR Part 15.407 & IC RSS-210	EQUIPMENT COMPLIES

MiCOM Labs, Inc. tested the equipment mentioned in accordance with the requirements set forth in the above standards. Test results indicate that the equipment tested is capable of demonstrating compliance with the requirements as documented within this report.

Notes:

1. This document reports conditions under which testing was conducted and the results of testing performed.
2. Details of test methods used have been recorded and kept on file by the laboratory.
3. Test results apply only to the item(s) tested.

Approved & Released for MiCOM Labs, Inc. by:



Graeme Grieve
Quality Manager MiCOM Labs,

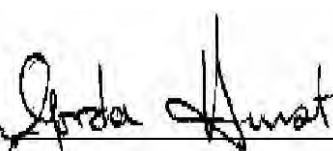

Gordon Hurst
President & CEO MiCOM Labs, Inc.



TESTING CERTIFICATE #2381.01

This test report may be reproduced in full only. The document may only be updated by MiCOM Labs personnel. Any changes will be noted in the Document History section of the report.

2. REFERENCES AND MEASUREMENT UNCERTAINTY

2.1. Normative References

Ref.	Publication	Year	Title
(i)	FCC 47 CFR Part 15.407	2012	Code of Federal Regulations
(ii)	FCC 06-96	June 2006	Memorandum Opinion and Order
(iii)	FCC OET KDB 662911	4 th April 2011	Emissions Testing of Transmitters with Multiple Outputs in the Same Band
(iv)	Industry Canada RSS-210	2010	Low Power License-Exempt Radiocommunication Devices (All Frequency Bands): Category 1 Equipment
(v)	Industry Canada RSS-Gen	2010	General Requirements and Information for the Certification of Radiocommunication Equipment
(vi)	ANSI C63.4	2009	American National Standards for Methods of Measurement of Radio-Noise Emissions from Low-Voltage Electrical and Electronic Equipment in the Range of 9 kHz to 40 GHz
(vii)	CISPR 22/ EN 55022	2008 2006+A1:2007	Limits and Methods of Measurements of Radio Disturbance Characteristics of Information Technology Equipment
(viii)	M 3003	Edition 1 Dec. 1997	Expression of Uncertainty and Confidence in Measurements
(ix)	LAB34	Edition 1 Aug 2002	The expression of uncertainty in EMC Testing
(x)	ETSI TR 100 028	2001	Parts 1 and 2 Electromagnetic compatibility and Radio Spectrum Matters (ERM); Uncertainties in the measurement of mobile radio equipment characteristics
(xi)	A2LA	July 2012	Reference to A2LA Accreditation Status – A2LA Advertising Policy
(xii)	FCC Public Notice – DA 02-2138	2002	Guidelines for Assessing Unlicensed National Information Infrastructure (U-NII) Devices



Title: APIN0114, APIN0115 802.11a/b/g/n
To: FCC 47 CFR Part 15.407 & IC RSS-210
Serial #: ARUB149-U4 Rev A
Issue Date: 5th August 2013
Page: 11 of 257

2.2. Test and Uncertainty Procedures

Conducted and radiated emission measurements were conducted in accordance with American National Standards Institute ANSI C63.4, listed in the Normative References section of this report.

Measurement uncertainty figures are calculated in accordance with ETSI TR 100 028 Parts 1 and 2.

Measurement uncertainties stated are based on a standard uncertainty multiplied by a coverage factor $k = 2$, providing a level of confidence of approximately 95 % in accordance with UKAS document M 3003 listed in the Normative References section of this report.

This test report may be reproduced in full only. The document may only be updated by MiCOM Labs personnel. Any changes will be noted in the Document History section of the report.



Title: APIN0114, APIN0115 802.11a/b/g/n
To: FCC 47 CFR Part 15.407 & IC RSS-210
Serial #: ARUB149-U4 Rev A
Issue Date: 5th August 2013
Page: 12 of 257

3. PRODUCT DETAILS AND TEST CONFIGURATIONS

3.1. Technical Details

Details	Description
Purpose:	Test of the APIN0114, APIN0115 802.11a/b/g/n in the frequency range 5,250 – 5,350 and 5,470 - 5725 MHz to FCC Part 15.407 and Industry Canada RSS-210 regulations.
Applicant:	Aruba Networks 1344 Crossman Avenue Sunnyvale, California 94089, USA
Manufacturer:	As applicant
Laboratory performing the tests:	MiCOM Labs, Inc. 440 Boulder Court, Suite 200 Pleasanton, California 94566 USA
Test report reference number:	ARUB149-U4 Rev A
Date EUT received:	10 th April 2013
Standard(s) applied:	FCC 47 CFR Part 15.407 & IC RSS-210
Dates of test (from - to):	10th - 31st July 2013
No of Units Tested:	One
Type of Equipment:	802.11a/b/g/n Wireless Access Point 3x3 Spatial Multiplexing MIMO configuration
Applicants Trade Name:	Wireless Access Point
Model(s):	APIN0114 & APIN0115
Location for use:	Indoor only
Declared Frequency Range(s):	5250 – 5,350 and 5,470 – 5,725 MHz
Hardware Rev	P2
Software Rev	AOS 6.3.0.0
Type of Modulation:	Per 802.11 – OFDM
EUT Modes of Operation:	Legacy 802.11a, 802.11n HT-20, HT-40
Declared Nominal Output Power: (Average Power)	802.11a: Legacy +18 dBm 802.11n: HT-20 +18 dBm 802.11n: HT-40 +18 dBm
Transmit/Receive Operation:	Time Division Duplex
System Beam Forming:	APIN0114 & APIN0115 has no capability for antenna beam forming
Rated Input Voltage and Current:	POE 56 Vdc Ac/dc adapter: 12 Vdc, 1.25 A
Operating Temperature Range:	Declared range 0° to +50°C
ITU Emission Designator:	802.11a 17M8D1D 802.11n HT-20 18M9D1D 802.11n HT-40 38M1D1D
Equipment Dimensions:	170mm (W) x 170mm (H) x 645mm (D)
Weight:	2 lbs
Primary function of equipment:	Wireless Access Point for transmitting data and voice.

This test report may be reproduced in full only. The document may only be updated by MiCOM Labs personnel. Any changes will be noted in the Document History section of the report.



Title: APIN0114, APIN0115 802.11a/b/g/n
To: FCC 47 CFR Part 15.407 & IC RSS-210
Serial #: ARUB149-U4 Rev A
Issue Date: 5th August 2013
Page: 13 of 257

3.2. Scope of Test Program

Aruba Networks APIN0114, APIN0115 Access Point RF Testing

The scope of the test program was to test the Aruba Networks APIN0114, APIN0115 Wireless LAN Access Point, 3X3 Spatial Multiplexing MIMO configurations in the frequency range 5,250 – 5,350 and 5,470 – 5,725 MHz for compliance against FCC 47 CFR Part 15.407 and Industry Canada RSS-210 specifications.

FCC OET KDB Implementation

This test program implements the following FCC KDB – 662911 4/4/2011;

Emissions Testing of Transmitters with Multiple Outputs in the Same Band

The KDB document provides guidance for measurements of conducted output emissions of devices that employ a single transmitter with multiple outputs in the same band, with the outputs occupying the same or overlapping frequency ranges. It applies to EMC compliance measurements on devices that transmit on multiple antennas simultaneously in the same or overlapping frequency ranges through a coordinated process. Examples include, but are not limited to, devices employing beam forming or multiple-input and multiple-output (MIMO.) This guidance applies to both licensed and unlicensed devices wherever the FCC rules call for conducted output measurements. Guidance is provided for in-band, out-of-band and spurious emission measurements.

This guidance does not apply to the multiple transmitters included in a composite device, such as a device that combines an 802.11 modem with a cell phone in one enclosure with each driving its own antenna.

This test report may be reproduced in full only. The document may only be updated by MiCOM Labs personnel. Any changes will be noted in the Document History section of the report.

Aruba Networks Inc
APIN0114 External Antenna 802.11 a/b/g/n/ac Wireless Access Point



Aruba Networks Inc
APIN0114, APIN0115 802.11 a/b/g/n/ac Wireless Access Point (Rear)



This test report may be reproduced in full only. The document may only be updated by MiCOM Labs personnel. Any changes will be noted in the Document History section of the report.



3.3. Equipment Model(s) and Serial Number(s)

Type (EUT/Support)	Equipment Description (Including Brand Name)	Mfr	Model No.	Serial No.
EUT	Wireless LAN Access Point	Aruba Networks	APIN0114	Engineering Sample
EUT	Wireless LAN Access Point (Integral Antenna)	Aruba Networks	APIN0115	Engineering Sample
Support	Laptop PC	IBM	Thinkpad	None

3.4. Antenna Details

Model	Type	Gain	Freq. Band	Note
		dBi	MHz	
AP-ANT-1B	Omni	3.8	2400 - 2500	(2x per unit)
		5.8	4900 - 5875	
AP-ANT-13B	Omni	4.4	2400 - 2500	(2x per unit)
		3.3	4900 - 5900	
AP-ANT-16	Omni	3.9	2400 - 2500	(1x per unit) 3x3 MIMO
		4.7	4900 - 5900	
AP-ANT-17	Directional 120degr.	6.0	2400 - 2500	(1x per unit) 3x3 MIMO
		5.0	4900 - 5875	
AP-ANT-18	Directional 60degr.	7.5	2400 - 2500	(1x per unit) 3x3 MIMO
		7.5	5150 - 5875	
AP-ANT-19	Omni	3.0	2400 - 2500	(2 x per unit)
		6.0	5150 - 5875	

This test report may be reproduced in full only. The document may only be updated by MiCOM Labs personnel. Any changes will be noted in the Document History section of the report.



APIN0115 Integrated Antennas

Model	Type	Gain	Freq. Band	Note
		dBi	MHz	
metal sheet	Omni	4.0	2400 - 2500	(3x per band, per unit)
		5.0	4900 - 5875	

3.5. Cabling and I/O Ports

Number and type of I/O ports

1. 2 x 10/100/1000 Ethernet ENET0, ENET1
2. Console - Serial maintenance terminal
3. 12 Vdc, supply connector
4. RF Antenna Connectors (x3) – Reverse SMA (APIN0114 Only)
5. USB



3.6. Test Configurations

Testing was performed to determine the highest power level versus bit rate. The variant with the highest power was used to exercise the product.

Matrix of test configurations

Operational Mode(s) (802.11)	Variant	Data Rates with Highest Power	Frequencies (MHz)
5250-5350 5470-5725	802.11a	6 MBit/s	5260,5280,5300,5320 5500,5580,5700
	802.11n HT-20	6.5 MBit/s	
	802.11n HT-40	13.5 MBit/s	5270,5310 5510,5550,5670

This test report may be reproduced in full only. The document may only be updated by MiCOM Labs personnel. Any changes will be noted in the Document History section of the report.



Spurious Emission and Band-Edge Test Strategy

Bands 5,250 – 5,350

11a	11n HT-20	11n HT-40
SE 5260	SE 5260	SE 5270
SE 5300	SE 5300	
SE 5320	SE 5320	SE 5310
BE 5350	BE 5350	BE 5350

KEY:-

SE – Spurious Emissions

BE – Band-Edge

Band 5,470 – 5,725

11a	11n HT-20	11n HT-40
SE 5500	SE 5500	SE 5510
SE 5580	SE 5580	SE 5550
SE 5700	SE 5700	SE 5670
BE 5470	BE 5470	BE 5470

3.7. Equipment Modifications

The following modifications were required to bring the equipment into compliance:

1. NONE

3.8. Deviations from the Test Standard

The following deviations from the test standard were required in order to complete the test program:

1. NONE

3.9. Subcontracted Testing or Third Party Data

1. NONE

4. TESTING EQUIPMENT CONFIGURATION(S)

4.1. Conducted RF Emission Test Set-up

The following tests were performed using the conducted test set-up shown in the diagram below.

1. Section 6.1.1.1. 26 dB and 99% Bandwidth
2. Section 6.1.1.2. Maximum Conducted Output Power
3. Section 6.1.1.3. Peak Power Spectral Density
4. Section 6.1.1.4. Peak Excursion Ratio

Conducted Test Set-Up Pictorial Representation

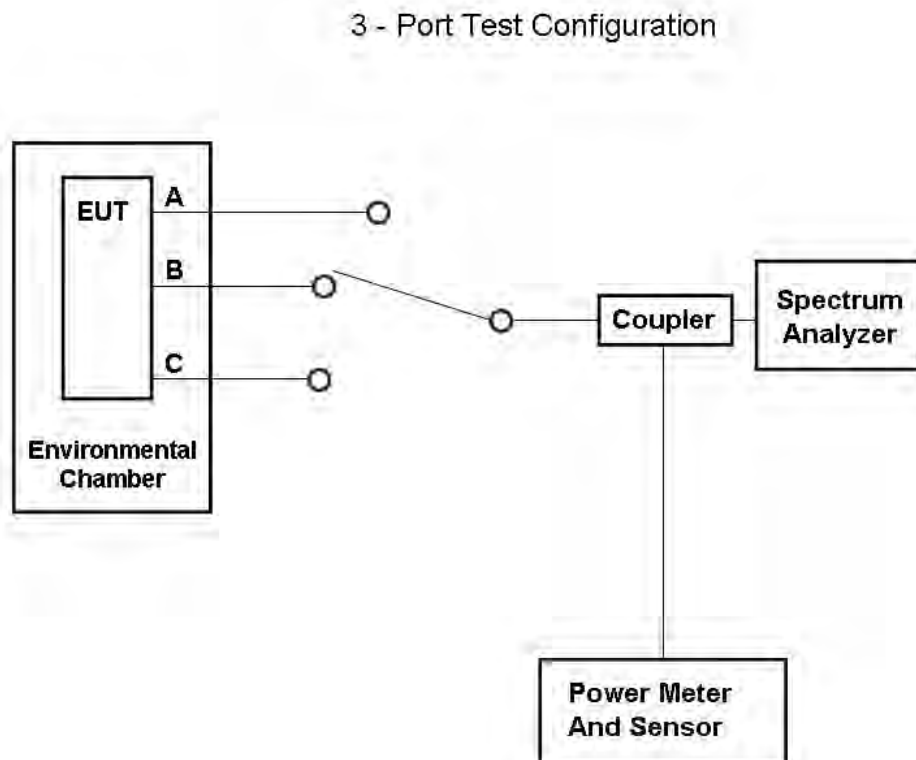

This test report may be reproduced in full only. The document may only be updated by MiCOM Labs personnel. Any changes will be noted in the Document History section of the report.

4.2. Radiated Spurious Emission Test Set-up > 1 GHz

The following tests were performed using the conducted test set-up shown in the diagram below.

1. Section 6.1.2.1 through 12

Radiated Emission Measurement Setup – Above 1 GHz

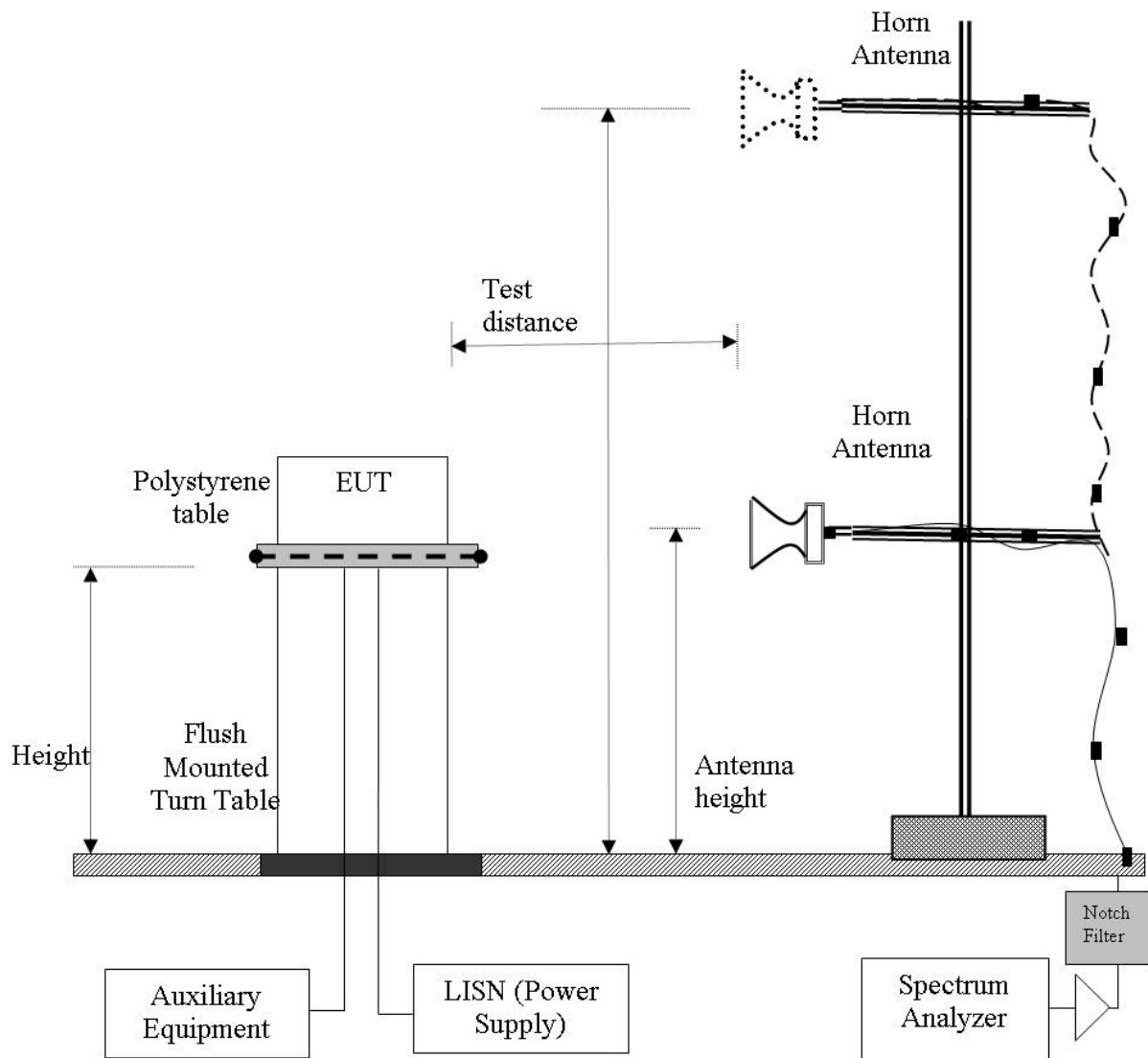

This test report may be reproduced in full only. The document may only be updated by MiCOM Labs personnel. Any changes will be noted in the Document History section of the report.

4.3. Digital Emissions Test Set-up (0.03 – 1 GHz)

The following tests were performed using the conducted test set-up shown in the diagram below.

2. Section 6.1.2.13

Digital Emission Measurement Setup – Below 1 GHz

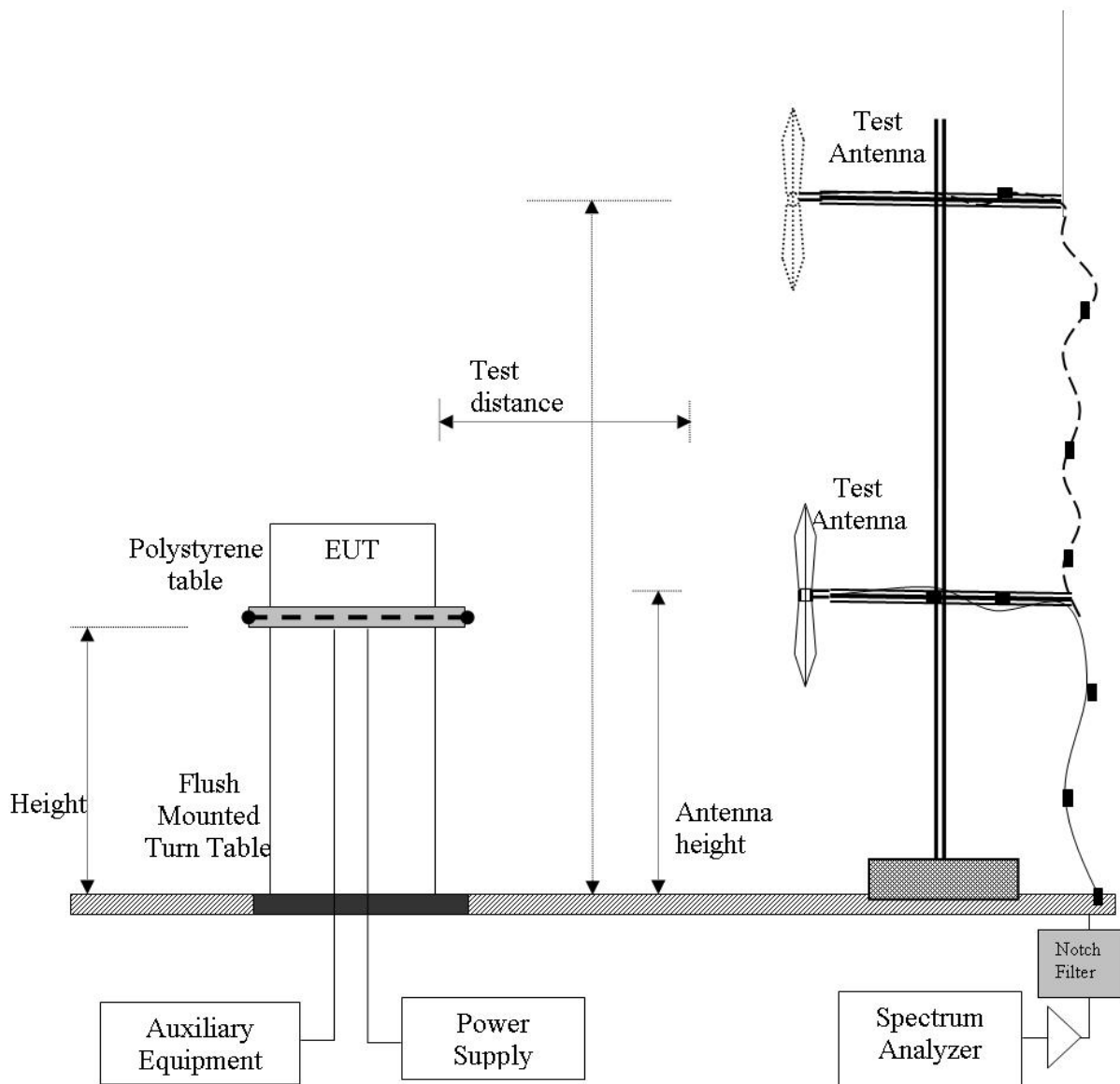

This test report may be reproduced in full only. The document may only be updated by MiCOM Labs personnel. Any changes will be noted in the Document History section of the report.

4.4. ac Wireline Emission Test Set-up

The following tests were performed using the conducted test set-up shown in the diagram below.

1. Section 6.1.3 ac Wireline Conducted Emissions

Conducted Test Set-Up Pictorial Representation

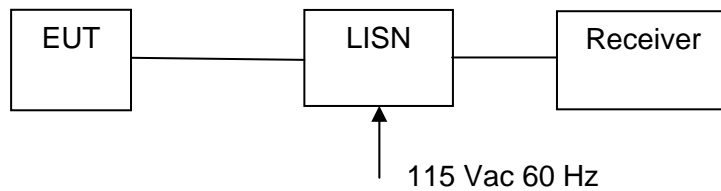

Measurement set up for ac Wireline Conducted Emissions Test



5. TEST SUMMARY

List of Measurements

The following table represents the list of measurements required under the **FCC CFR47 Part 15.407** and **Industry Canada RSS-210** and **Industry Canada RSS-Gen**.

Section(s)	Test Items	Description	Condition	Result	Test Report Section
15.407(a) A9.2(2) 4.4	26dB and 99% Emission BW	Emission bandwidth measurement	Conducted	Complies	6.1.1.1 A.1.1
15.407(a) A9.2(2) 4.6	Maximum Conducted Output Power	Power Measurement	Conducted	Complies	6.1.1.2
15.407(a) A9.2(2)	Peak Power Spectral Density	PPSD	Conducted	Complies	6.1.1.3 A.1.2
15.407(a)(6)	Peak Excursion Ratio	<13dB in any 1MHz bandwidth	Conducted	Complies	6.1.1.4 A.1.3
15.407(g) 15.31 2.1 4.5	Frequency Stability	Limits: contained within band of operation at all times.	Applicant declaration	Complies	6.1.1.5
15.407(f) 5.5	Radio Frequency Radiation Exposure	Exposure to radio frequency energy levels, Maximum Permissible Exposure (MPE)	Conducted	See included MPE exhibit	--

This test report may be reproduced in full only. The document may only be updated by MiCOM Labs personnel. Any changes will be noted in the Document History section of the report.



List of Measurements (continued)

The following table represents the list of measurements required under the **FCC CFR47 Part 15.407** and **Industry Canada RSS-210** and **Industry Canada RSS-Gen**.

Section(s)	Test Items	Description	Condition	Result	Test Report Section
15.407(b)(2) 15.205(a) 15.209(a) 2.2 2.6 A9.3(2) 4.7	Radiated Emissions		Radiated		6.1.2
	Transmitter Radiated Spurious Emissions	Emissions above 1 GHz		Complies	6.1.2.1 6.1.2.2 6.1.2.3
	Radiated Band Edge	Band edge results		Complies	6.1.2.1 6.1.2.2 6.1.2.3
15.407(b)(6) 15.205(a) 15.209(a) 2.2	Radiated Emissions	Emissions <1 GHz (30M-1 GHz)		Complies	6.1.2.4
15.407(b)(6) 15.207 7.2.2	AC Wireline Conducted Emissions 150 kHz–30 MHz	Conducted Emissions	Conducted	Complies ac/dc adaptor only, POE not marketed with equipment	6.1.3

Note 1: Test results reported in this document relate only to the items tested

Note 2: The required tests demonstrated compliance as per client declaration of test configuration, monitoring methodology and associated pass/fail criteria

Note 3: Section 3.7 Equipment Modifications highlights the equipment modifications that were required to bring the product into compliance with the above test matrix



List of Measurements (cont'd)

Dynamic Frequency Selection (DFS)

The following table represents the list of measurements required under the **FCC CFR47 Part 15.407(h)(2)** and **FCC Memorandum Opinion and Order FCC 06-96 (Compliance Measurement procedures for Unlicensed National Information Infrastructure devices operating in the 5250-5350 MHz and 5470-5725 MHz bands incorporating dynamic frequency selection)**.

Tests performed on Master Device

Section	Test Items	Description	Condition	Result	Test Report Section
	DFS	Dynamic Frequency Selection	Conducted		6.1.4
7.8.1	Detection Bandwidth	UNII Detection Bandwidth	Conducted	Complies	
7.8.2.1	Performance Requirements Check	Initial Channel Availability Check Time	Conducted	Complies	
7.8.2.2		Radar Burst at the Beginning of the Channel Availability Check Time	Conducted	Complies	
7.8.2.3		Radar Burst at the End of the Channel Availability Check Time	Conducted	Complies	
7.8.3	In-Service Monitoring	In-Service Monitoring for Channel Move Time, Channel Closing Transmission Time and Non-Occupancy Period	Conducted	Complies	
7.8.4	Radar Detection	Statistical Performance Check	Conducted	Complies	

This test report may be reproduced in full only. The document may only be updated by MiCOM Labs personnel. Any changes will be noted in the Document History section of the report.



Title: APIN0114, APIN0115 802.11a/b/g/n
To: FCC 47 CFR Part 15.407 & IC RSS-210
Serial #: ARUB149-U4 Rev A
Issue Date: 5th August 2013
Page: 27 of 257

6. TEST RESULTS

6.1. Device Characteristics

6.1.1. Conducted Testing

6.1.1.1. 26 dB and 99 % Bandwidth

Conducted Test Conditions for 26 dB and 99% Bandwidth			
Standard:	FCC CFR 47:15.407	Ambient Temp. (°C):	24.0 - 27.5
Test Heading:	26 dB and 99 % Bandwidth	Rel. Humidity (%):	32 - 45
Standard Section(s):	15.407 (a)	Pressure (mBars):	999 - 1001
Reference Document(s):	KDB 789033 - D01 DTS General UNII Test Procedures v01		

Test Procedure for 26 dB and 99% Bandwidth Measurement

The bandwidth at 26 dB and 99 % is measured with a spectrum analyzer connected to the antenna terminal, while EUT is operating in transmission mode at the appropriate center frequency. KDB 789033 Section 5.1 Emission Bandwidth was used in order to prove compliance. The Resolution Bandwidth was set to approximately 1% of the emission bandwidth.

This test report may be reproduced in full only. The document may only be updated by MiCOM Labs personnel. Any changes will be noted in the Document History section of the report.



Title: APIN0114, APIN0115 802.11a/b/g/n
To: FCC 47 CFR Part 15.407 & IC RSS-210
Serial #: ARUB149-U4 Rev A
Issue Date: 5th August 2013
Page: 28 of 257

Measurement Results for 26 dB and 99 % Operational Bandwidth(s)

Equipment Configuration for 26 dB & 99% Occupied Bandwidth

Variant:	802.11a	Duty Cycle (%):	100
Data Rate:	6 MBit/s	Antenna Gain (dBi):	Not Applicable
Modulation:	OFDM	Beam Forming Gain (Y):	Not Applicable
TPC:	Not Applicable		
Engineering Test Notes:			

Test Measurement Results

Test Frequency	Measured 26 dB Bandwidth (MHz)				26 dB Bandwidth (MHz)			
	Port(s)				Highest	Lowest		
MHz	a	b	c	d				
5260.0	25.752	22.445	22.946	--	25.752	22.445		
5300.0	25.651	22.645	22.345	--	25.651	22.345		
5320.0	28.156	22.545	22.445	--	28.156	22.445		

Test Frequency	Measured 99% Bandwidth (MHz)				99% Bandwidth (MHz)			
	Port(s)				Highest	Lowest		
MHz	a	b	c	d				
5260.0	16.934	16.733	16.733	--	16.934	16.733		
5300.0	16.934	16.733	16.633	--	16.934	16.633		
5320.0	17.034	16.733	16.633	--	17.034	16.633		

Traceability to Industry Recognized Test Methodologies

Work Instruction:	WI-03 MEASURING RF SPECTRUM MASK
Measurement Uncertainty:	±2.81 dB

This test report may be reproduced in full only. The document may only be updated by MiCOM Labs personnel. Any changes will be noted in the Document History section of the report.



Title: APIN0114, APIN0115 802.11a/b/g/n
To: FCC 47 CFR Part 15.407 & IC RSS-210
Serial #: ARUB149-U4 Rev A
Issue Date: 5th August 2013
Page: 29 of 257

Equipment Configuration for 26 dB & 99% Occupied Bandwidth

Variant:	802.11a	Duty Cycle (%):	100
Data Rate:	6 MBit/s	Antenna Gain (dBi):	Not Applicable
Modulation:	OFDM	Beam Forming Gain (Y):	Not Applicable
TPC:	Not Applicable		
Engineering Test Notes:			

Test Measurement Results

Test Frequency	Measured 26 dB Bandwidth (MHz)				26 dB Bandwidth (MHz)			
	Port(s)				Highest	Lowest		
MHz	a	b	c	d				
5500.0	37.876	23.948	22.545	--	37.876	22.545		
5580.0	33.567	23.447	22.745	--	33.567	22.745		
5700.0	32.265	28.557	22.645	--	32.265	22.645		

Test Frequency	Measured 99% Bandwidth (MHz)				99% Bandwidth (MHz)			
	Port(s)				Highest	Lowest		
MHz	a	b	c	d				
5500.0	17.836	16.633	16.733	--	17.836	16.633		
5580.0	17.335	16.733	16.633	--	17.335	16.633		
5700.0	17.435	16.834	16.633	--	17.435	16.633		

Traceability to Industry Recognized Test Methodologies

Work Instruction:	WI-03 MEASURING RF SPECTRUM MASK
Measurement Uncertainty:	±2.81 dB

This test report may be reproduced in full only. The document may only be updated by MiCOM Labs personnel. Any changes will be noted in the Document History section of the report.



Title: APIN0114, APIN0115 802.11a/b/g/n
To: FCC 47 CFR Part 15.407 & IC RSS-210
Serial #: ARUB149-U4 Rev A
Issue Date: 5th August 2013
Page: 30 of 257

Equipment Configuration for 26 dB & 99% Occupied Bandwidth

Variant:	802.11n HT-20	Duty Cycle (%):	100
Data Rate:	6.5 MBit/s	Antenna Gain (dBi):	Not Applicable
Modulation:	OFDM	Beam Forming Gain (Y):	Not Applicable
TPC:	Not Applicable		
Engineering Test Notes:			

Test Measurement Results

Test Frequency	Measured 26 dB Bandwidth (MHz)				26 dB Bandwidth (MHz)			
	Port(s)				Highest	Lowest		
MHz	a	b	c	d				
5260.0	26.453	23.246	23.246	--	26.453	23.246		
5300.0	27.856	22.946	23.948	--	27.856	22.946		
5320.0	28.758	23.547	23.447	--	28.758	23.447		

Test Frequency	Measured 99% Bandwidth (MHz)				99% Bandwidth (MHz)			
	Port(s)				Highest	Lowest		
MHz	a	b	c	d				
5260.0	18.036	17.836	17.735	--	18.036	17.735		
5300.0	18.036	17.735	17.735	--	18.036	17.735		
5320.0	18.036	17.936	17.735	--	18.036	17.735		

Traceability to Industry Recognized Test Methodologies

Work Instruction:	WI-03 MEASURING RF SPECTRUM MASK
Measurement Uncertainty:	±2.81 dB

This test report may be reproduced in full only. The document may only be updated by MiCOM Labs personnel. Any changes will be noted in the Document History section of the report.



Title: APIN0114, APIN0115 802.11a/b/g/n
To: FCC 47 CFR Part 15.407 & IC RSS-210
Serial #: ARUB149-U4 Rev A
Issue Date: 5th August 2013
Page: 31 of 257

Equipment Configuration for 26 dB & 99% Occupied Bandwidth

Variant:	802.11n HT-20	Duty Cycle (%):	100
Data Rate:	6.5 MBit/s	Antenna Gain (dBi):	Not Applicable
Modulation:	OFDM	Beam Forming Gain (Y):	Not Applicable
TPC:	Not Applicable		
Engineering Test Notes:			

Test Measurement Results

Test Frequency	Measured 26 dB Bandwidth (MHz)				26 dB Bandwidth (MHz)			
	Port(s)				Highest	Lowest		
MHz	a	b	c	d				
5500.0	36.774	23.547	23.246	--	36.774	23.246		
5580.0	35.371	25.551	23.647	--	35.371	23.647		
5700.0	37.976	26.653	23.647	--	37.976	23.647		

Test Frequency	Measured 99% Bandwidth (MHz)				99% Bandwidth (MHz)			
	Port(s)				Highest	Lowest		
MHz	a	b	c	d				
5500.0	18.938	17.836	17.836	--	18.938	17.836		
5580.0	18.637	17.836	17.836	--	18.637	17.836		
5700.0	19.238	17.936	17.836	--	19.238	17.836		

Traceability to Industry Recognized Test Methodologies

Work Instruction:	WI-03 MEASURING RF SPECTRUM MASK
Measurement Uncertainty:	±2.81 dB

This test report may be reproduced in full only. The document may only be updated by MiCOM Labs personnel. Any changes will be noted in the Document History section of the report.



Title: APIN0114, APIN0115 802.11a/b/g/n
To: FCC 47 CFR Part 15.407 & IC RSS-210
Serial #: ARUB149-U4 Rev A
Issue Date: 5th August 2013
Page: 32 of 257

Equipment Configuration for 26 dB & 99% Occupied Bandwidth

Variant:	802.11n HT-40	Duty Cycle (%):	100
Data Rate:	13.5 MBit/s	Antenna Gain (dBi):	Not Applicable
Modulation:	OFDM	Beam Forming Gain (Y):	Not Applicable
TPC:	Not Applicable		
Engineering Test Notes:			

Test Measurement Results

Test Frequency	Measured 26 dB Bandwidth (MHz)				26 dB Bandwidth (MHz)			
	Port(s)				Highest	Lowest		
MHz	a	b	c	d				
5270.0	54.910	43.888	46.092	--	54.910	43.888		
5310.0	71.944	44.489	46.894	--	71.944	44.489		

Test Frequency	Measured 99% Bandwidth (MHz)				99% Bandwidth (MHz)			
	Port(s)				Highest	Lowest		
MHz	a	b	c	d				
5270.0	36.473	36.273	36.473	--	36.473	36.273		
5310.0	36.673	36.273	36.273	--	36.673	36.273		

Traceability to Industry Recognized Test Methodologies

Work Instruction:	WI-03 MEASURING RF SPECTRUM MASK
Measurement Uncertainty:	±2.81 dB

This test report may be reproduced in full only. The document may only be updated by MiCOM Labs personnel. Any changes will be noted in the Document History section of the report.



Title: APIN0114, APIN0115 802.11a/b/g/n
To: FCC 47 CFR Part 15.407 & IC RSS-210
Serial #: ARUB149-U4 Rev A
Issue Date: 5th August 2013
Page: 33 of 257

Equipment Configuration for 26 dB & 99% Occupied Bandwidth

Variant:	802.11n HT-40	Duty Cycle (%):	100
Data Rate:	13.5 MBit/s	Antenna Gain (dBi):	Not Applicable
Modulation:	OFDM	Beam Forming Gain (Y):	Not Applicable
TPC:	Not Applicable		
Engineering Test Notes:			

Test Measurement Results

Test Frequency	Measured 26 dB Bandwidth (MHz)				26 dB Bandwidth (MHz)			
	Port(s)				Highest	Lowest		
MHz	a	b	c	d				
5510.0	80.160	44.489	45.491	--	80.160	44.489		
5550.0	45.291	45.291	45.291	--	45.291	22.645		
5670.0	76.353	48.096	44.088	--	76.353	44.088		

Test Frequency	Measured 99% Bandwidth (MHz)				99% Bandwidth (MHz)			
	Port(s)				Highest	Lowest		
MHz	a	b	c	d				
5510.0	38.076	36.273	36.273	--	38.076	36.273		
5550.0	37.074	36.273	36.273	--	37.074	36.273		
5670.0	36.874	36.273	36.273	--	36.874	36.273		

Traceability to Industry Recognized Test Methodologies

Work Instruction:	WI-03 MEASURING RF SPECTRUM MASK
Measurement Uncertainty:	±2.81 dB

This test report may be reproduced in full only. The document may only be updated by MiCOM Labs personnel. Any changes will be noted in the Document History section of the report.



Specification

Limits

FCC, Part 15 §15.407 (a)(1), (a)(2) and Industry Canada RSS-210 § A9.2(2)

(a)(1) For the band 5.15-5.25 GHz the maximum conducted output power over the frequency band of operation shall not exceed the lesser of 50 mW or $+4 \text{ dBm} + 10 \log B$, where B is the 26 dB emission bandwidth in megahertz. In addition, the peak power spectral density shall not exceed +4 dBm in any 1 megahertz band.

(a)(2) For the 5.25-5.35 GHz band the maximum conducted output power over the frequency band of operation shall not exceed the lesser of 250 mW or $+11 \text{ dBm} + 10 \log B$, where B is the 26 dB emission bandwidth in megahertz. In addition, the peak power spectral density shall not exceed +11 dBm in any 1 megahertz band.

Industry Canada RSS-Gen 4.4

When an occupied bandwidth value is not specified in the applicable RSS, the transmitted signal bandwidth to be reported is to be its 99% emission bandwidth, as calculated or measured.

Traceability

Test Equipment Used

0158, 0287, 0252, 0313, 0314, 0070, 0116, 0117



Title: APIN0114, APIN0115 802.11a/b/g/n
To: FCC 47 CFR Part 15.407 & IC RSS-210
Serial #: ARUB149-U4 Rev A
Issue Date: 5th August 2013
Page: 35 of 257

6.1.1.2. Maximum Conducted Output Power

Conducted Test Conditions for Maximum Conducted Output Power			
Standard:	FCC CFR 47:15.407	Ambient Temp. (°C):	24.0 - 27.5
Test Heading:	Maximum Conducted Output Power	Rel. Humidity (%):	32 - 45
Standard Section(s):	15.407 (a)	Pressure (mBars):	999 - 1001
Reference Document(s):	KDB 789033 - D01 DTS General UNII Test Procedures v01		

Test Procedure for Maximum Conducted Output Power Measurement

Method PM (Measurement using an RF average power meter). Section C) 4) of KDB 789033 defines a methodology using an average wideband power meter. Measurements were made while the EUT was operating in a continuous transmission mode (100% duty cycle) at the appropriate center frequency. All cable losses and offsets were taken into consideration in the measured result. All operational modes and frequency bands were measured independently and the resultant calculated. For multiple outputs, the measurements were made simultaneously on each output port and summed in a linear fashion. This technique was used in order to prove compliance.

This test report may be reproduced in full only. The document may only be updated by MiCOM Labs personnel. Any changes will be noted in the Document History section of the report.



Antenna Beam and Non-Beam Forming Power Levels

15. 407 (a)(1), (a) (2) Operation with directional antenna gains greater than 6 dBi.

If transmitting antennas of directional gain greater than 6 dBi are used, the conducted output power from the intentional radiator shall be reduced by the amount in dB that the directional gain of the antenna exceeds 6 dBi. Further FCC KDB 662911 D01 Multiple Transmitter Output v01 requires that the gain of antennas transmitting the same data (legacy 802.11a mode) must be increased by $10 * \log(N)$ when N is the number of antenna elements.

The APIN0114 and APIN0115 does not implement beam-forming

Maximum Transmit (Conducted) Power, FCC Limits and Industry Canada Limits

FCC Limits Bands 5250 – 5350

Limit lesser of: 250 mW or $11 \text{ dBm} + 10 \log(B) \text{ dBm}$.

Mode	Frequency Range (MHz)	Maximum 26 dB Bandwidth (MHz)	11 + 10 Log (B) (dBm)	Limit (dBm)
a	5250 – 5350 5470 – 5725	22.345	24.492	+24.0
HT-20		22.946	24.607	+24.0
HT-40		46.092	27.636	+24.0

Industry Canada Limits

Bands 5250 – 5350

Limit lesser of: 250 mW or $11 \text{ dBm} + 10 \log(B) \text{ dBm}$.

Mode	Frequency Range (MHz)	99% Bandwidth (MHz)	11 + 10 Log (B) (dBm)	Limit (dBm)
a	5250 – 5350 5470 – 5725	16.633	23.210	+23.2
HT-20		17.735	23.488	+23.5
HT-40		36.273	26.596	+24.0



FCC Limits

Bands 5470 – 5725 MHz

Limit lesser of: 250 mW or 11 dBm + 10 log (B) dBm.

Mode	Frequency Range (MHz)	Maximum 26 dB Bandwidth (MHz)	11 + 10 Log (B) (dBm)	Limit (dBm)
a	5250 – 5350	22.645	24.551	+24.0
HT-20		23.246	24.663	+24.0
HT-40	5470 – 5725	44.088	27.443	+24.0

Industry Canada Limits

Bands 5470 – 5725 MHz

Limit lesser of: 250 mW or 11 dBm + 10 log (B) dBm.

Mode	Frequency Range (MHz)	99% Bandwidth (MHz)	11 + 10 Log (B) (dBm)	Limit (dBm)
a	5250 – 5350	16.633	23.210	+23.2
HT-20		17.836	23.513	+23.5
HT-40	5470 – 5725	36.273	26.569	+24.0



Title: APIN0114, APIN0115 802.11a/b/g/n
To: FCC 47 CFR Part 15.407 & IC RSS-210
Serial #: ARUB149-U4 Rev A
Issue Date: 5th August 2013
Page: 38 of 257

Equipment Configuration for Peak Transmit Power

Variant:	802.11a	Duty Cycle (%):	100
Data Rate:	6 MBit/s	Antenna Gain (dBi):	3.30
Modulation:	OFDM	Beam Forming Gain (Y):	Not Applicable
TPC:	Not Applicable		
Engineering Test Notes:			

Test Measurement Results										
Test Frequency	Measured Conducted Output Power (dBm)				Calculated Total Power	Minimum 26 dB Bandwidth	Limit	Margin	EUT Power Setting	
	Port(s)									
MHz	a	b	c	d	Σ Port(s) dBm	MHz	dBm	dBm		
5260.0	16.55	16.95	18.30	--	22.10	22.445	24.00	-1.90	15.00	
5300.0	16.66	16.53	17.20	--	21.58	22.345	24.00	-2.42	15.00	
5320.0	16.81	16.95	17.29	--	21.79	22.445	24.00	-2.21	15.00	

Traceability to Industry Recognized Test Methodologies	
Work Instruction:	WI-03 MEASURING RF SPECTRUM MASK
Measurement Uncertainty:	±2.81 dB

Equipment Configuration for Peak Transmit Power

Variant:	802.11a	Duty Cycle (%):	100
Data Rate:	6 MBit/s	Antenna Gain (dBi):	3.30
Modulation:	OFDM	Beam Forming Gain (Y):	Not Applicable
TPC:	Not Applicable		
Engineering Test Notes:			

Test Measurement Results										
Test Frequency	Measured Conducted Output Power (dBm)				Calculated Total Power	Minimum 26 dB Bandwidth	Limit	Margin	EUT Power Setting	
	Port(s)									
MHz	a	b	c	d	Σ Port(s) dBm	MHz	dBm	dBm		
5500.0	17.11	17.36	17.27	--	22.02	22.545	24.00	-1.98	17.00	
5580.0	15.81	17.36	17.06	--	21.56	22.745	24.00	-2.44	15.50	
5700.0	16.00	17.61	17.14	--	21.74	22.645	24.00	-2.26	15.50	

Traceability to Industry Recognized Test Methodologies	
Work Instruction:	WI-03 MEASURING RF SPECTRUM MASK
Measurement Uncertainty:	±2.81 dB

This test report may be reproduced in full only. The document may only be updated by MiCOM Labs personnel. Any changes will be noted in the Document History section of the report.



Title: APIN0114, APIN0115 802.11a/b/g/n
To: FCC 47 CFR Part 15.407 & IC RSS-210
Serial #: ARUB149-U4 Rev A
Issue Date: 5th August 2013
Page: 39 of 257

Equipment Configuration for Peak Transmit Power

Variant:	802.11n HT-20	Duty Cycle (%):	100
Data Rate:	6.5 MBit/s	Antenna Gain (dBi):	3.30
Modulation:	OFDM	Beam Forming Gain (Y):	Not Applicable
TPC:	Not Applicable		
Engineering Test Notes:			

Test Measurement Results

Test Frequency	Measured Conducted Output Power (dBm)				Calculated Total Power	Minimum 26 dB Bandwidth	Limit	Margin	EUT Power Setting
	Port(s)								
MHz	a	b	c	d	Σ Port(s) dBm	MHz	dBm	dBm	
5260.0	16.09	16.27	17.70	--	21.52	23.246	24.00	-2.48	13.50
5300.0	16.58	16.26	16.89	--	21.36	22.946	24.00	-2.64	14.00
5320.0	16.72	16.65	16.95	--	21.55	23.447	24.00	-2.45	14.00

Traceability to Industry Recognized Test Methodologies

Work Instruction:	WI-03 MEASURING RF SPECTRUM MASK
Measurement Uncertainty:	±2.81 dB

Equipment Configuration for Peak Transmit Power

Variant:	802.11n HT-20	Duty Cycle (%):	100
Data Rate:	6.5 MBit/s	Antenna Gain (dBi):	3.30
Modulation:	OFDM	Beam Forming Gain (Y):	N/A
TPC:	N/A		
Engineering Test Notes:			

Test Measurement Results

Test Frequency	Measured Conducted Output Power (dBm)				Calculated Total Power	Minimum 26 dB Bandwidth	Limit	Margin	EUT Power Setting
	Port(s)								
MHz	a	b	c	d	Σ Port(s) dBm	MHz	dBm	dBm	
5500.0	16.90	17.30	17.29		21.94	23.246	24.00	-2.06	17.50
5580.0	16.00	17.91	17.73		22.07	23.647	24.00	-1.93	16.50
5700.0	16.52	18.39	18.00		22.48	23.647	24.00	-1.52	15.50

Traceability to Industry Recognized Test Methodologies

Work Instruction:	WI-03 MEASURING RF SPECTRUM MASK
Measurement Uncertainty:	±2.81 dB

This test report may be reproduced in full only. The document may only be updated by MiCOM Labs personnel. Any changes will be noted in the Document History section of the report.



Title: APIN0114, APIN0115 802.11a/b/g/n
To: FCC 47 CFR Part 15.407 & IC RSS-210
Serial #: ARUB149-U4 Rev A
Issue Date: 5th August 2013
Page: 40 of 257

Equipment Configuration for Peak Transmit Power

Variant:	802.11n HT-40	Duty Cycle (%):	100
Data Rate:	13.5 MBit/s	Antenna Gain (dBi):	3.30
Modulation:	OFDM	Beam Forming Gain (Y):	Not Applicable
TPC:	Not Applicable		
Engineering Test Notes:			

Test Measurement Results

Test Frequency	Measured Conducted Output Power (dBm)				Calculated Total Power	Minimum 26 dB Bandwidth	Limit	Margin	EUT Power Setting
	Port(s)								
MHz	a	b	c	d	Σ Port(s) dBm	MHz	dBm	dBm	
5270.0	16.86	17.63	18.89	--	22.65	43.888	24.00	-1.35	15.00
5310.0	18.26	18.40	18.96	--	23.32	44.489	24.00	-0.68	16.00

Traceability to Industry Recognized Test Methodologies

Work Instruction:	WI-03 MEASURING RF SPECTRUM MASK
Measurement Uncertainty:	±2.81 dB

Equipment Configuration for Peak Transmit Power

Variant:	802.11n HT-40	Duty Cycle (%):	100
Data Rate:	13.5 MBit/s	Antenna Gain (dBi):	3.30
Modulation:	OFDM	Beam Forming Gain (Y):	Not Applicable
TPC:	Not Applicable		
Engineering Test Notes:			

Test Measurement Results

Test Frequency	Measured Conducted Output Power (dBm)				Calculated Total Power	Minimum 26 dB Bandwidth	Limit	Margin	EUT Power Setting
	Port(s)								
MHz	a	b	c	d	Σ Port(s) dBm	MHz	dBm	dBm	
5510.0	17.39	18.16	18.18	--	22.70	44.489	24.00	-1.30	18.50
5550.0	16.73	18.37	17.88	--	22.48	22.645	24.00	-1.52	17.50
5670.0	16.57	18.35	17.89	--	22.44	44.088	24.00	-1.56	16.50

Traceability to Industry Recognized Test Methodologies

Work Instruction:	WI-03 MEASURING RF SPECTRUM MASK
Measurement Uncertainty:	±2.81 dB

This test report may be reproduced in full only. The document may only be updated by MiCOM Labs personnel. Any changes will be noted in the Document History section of the report.



Measurement Results for Maximum Conducted Output Power

Specification Limits

FCC, Part 15 §15.407 (a)(1), (a)(2) and Industry Canada RSS-210 § A9.2(2)

(a)(1) For the band 5.15-5.25 GHz the maximum conducted output power over the frequency band of operation shall not exceed the lesser of 50 mW or +4 dBm + 10 log B, where B is the 26 dB emission bandwidth in megahertz. In addition, the peak power spectral density shall not exceed +4 dBm in any 1 megahertz band.

(a)(2) For the 5.25-5.35 and 5470-5725 MHz GHz band the maximum conducted output power over the frequency band of operation shall not exceed the lesser of 250 mW or +11 dBm + 10 log B, where B is the 26 dB emission bandwidth in megahertz. In addition, the peak power spectral density shall not exceed +11 dBm in any 1 megahertz band.

Industry Canada RSS-210 §A9.2(2)

For the band 5150-5250 MHz, the maximum equivalent isotropically radiated power (e.i.r.p.) shall not exceed 200 mW or 10 + 10 log₁₀ B, dBm, whichever power is less. B is the 99% emission bandwidth in MHz. The e.i.r.p. spectral density shall not exceed 10 dBm in any 1.0 MHz band.

For the band 5250-5350 MHz and 5470-5725 MHz, the maximum conducted output power shall not exceed 250 mW or 11 + 10 log₁₀ B, dBm, whichever power is less. The power spectral density shall not exceed 11 dBm in any 1.0 MHz band. The maximum e.i.r.p. shall not exceed 1.0 W or 17 + 10 log₁₀ B, dBm, whichever power is less. B is the 99% emission bandwidth in MHz.

Traceability

Test Equipment Used

0158, 0287, 0252, 0313, 0314, 0070, 0116, 0117
--



Title: APIN0114, APIN0115 802.11a/b/g/n
To: FCC 47 CFR Part 15.407 & IC RSS-210
Serial #: ARUB149-U4 Rev A
Issue Date: 5th August 2013
Page: 42 of 257

6.1.1.3. Peak Power Spectral Density

Conducted Test Conditions for Power Spectral Density			
Standard:	FCC CFR 47:15.407	Ambient Temp. (°C):	24.0 - 27.5
Test Heading:	Power Spectral Density	Rel. Humidity (%):	32 - 45
Standard Section(s):	15.247 (a)	Pressure (mBars):	999 - 1001
Reference Document(s):	KDB 789033 - D01 DTS General UNII Test Procedures v01		
Test Procedure for Power Spectral Density			
The In-Band power spectral density was measured using the measure and sum approach per FCC KDB 662911 (D01 Multiple Transmitter Output v01.)			
<u>Measure and sum the spectra across the outputs.</u> With this technique, spectra are measured at each output of the device at the required resolution bandwidth. The individual spectra are then summed mathematically in linear power units. Unlike in-band power measurements, in which the sum involves a single measured value (output power) from each output, measurements for compliance with PSD limits involve summing entire spectra across corresponding frequency bins on the various outputs. Consistency is maintained for any device with N transmitter outputs to be certain the individual outputs are all aligned with the same span and same number of points. In this instance, the linear power spectrum value within the first spectral bin of output 0 is summed with that in the first spectral bin of output 1, and the first spectral bin of output 2, and so on up to the Nth output to obtain the true value for the first frequency bin of the summed spectrum. The summed spectrum value for each frequency bin is computed in this fashion. These summed spectral values were calculated on a computer, and the results read back into the spectrum analyzer as a data file to produce a representative plot of total spectral power density.			
<u>NOTE:</u>			
It may be observed that spectrum in some plots break the limit line however this in itself does NOT constitute a failure. In this case a summation plot for all spectrum plots is provided to prove compliance. A failure occurs only after the summation of all spectrum plots have been summed and are found to be greater than the limit line.			
<u>Supporting Information</u>			
Calculated Power = $A + 10 \log (1/x)$ dBm			
A = Total Power Spectral Density [10 Log10 (10a/10 + 10 b/10 + 10c/10 + 10d/10)]			
x = Duty Cycle			

This test report may be reproduced in full only. The document may only be updated by MiCOM Labs personnel. Any changes will be noted in the Document History section of the report.



Title: APIN0114, APIN0115 802.11a/b/g/n
To: FCC 47 CFR Part 15.407 & IC RSS-210
Serial #: ARUB149-U4 Rev A
Issue Date: 5th August 2013
Page: 43 of 257

Equipment Configuration for Peak Power Spectral Density

Variant:	802.11a	Duty Cycle (%):	100
Data Rate:	6 MBit/s	Antenna Gain (dBi):	Not Applicable
Modulation:	OFDM	Beam Forming Gain (Y):	Not Applicable
TPC:	Not Applicable		
Engineering Test Notes:			

Test Measurement Results

Test Frequency	Measured Power Spectral Density (dBm)				Calculated Total Power Spectral Density (dBm)	Limit	Margin
	Port(s)						
MHz	a	b	c	d	Σ Port(s)	dBm	dB
5260.0	5.835	6.087	6.707	--	10.997	≤ 11.00	0.00
5300.0	5.819	5.415	6.229	--	10.605	≤ 11.00	-0.40
5320.0	5.800	5.711	6.212	--	10.684	≤ 11.00	-0.32

Traceability to Industry Recognized Test Methodologies

Work Instruction:	WI-03 MEASURING RF SPECTRUM MASK
Measurement Uncertainty:	±2.81 dB

Equipment Configuration for Peak Power Spectral Density

Variant:	802.11a	Duty Cycle (%):	100
Data Rate:	6 MBit/s	Antenna Gain (dBi):	Not Applicable
Modulation:	OFDM	Beam Forming Gain (Y):	Not Applicable
TPC:	Not Applicable		
Engineering Test Notes:			

Test Measurement Results

Test Frequency	Measured Power Spectral Density (dBm)				Calculated Total Power Spectral Density (dBm)	Limit	Margin
	Port(s)						
MHz	a	b	c	d	Σ Port(s)	dBm	dB
5500.0	6.173	6.148	6.238	--	10.958	≤ 11.00	-0.04
5580.0	4.987	6.611	6.392	--	10.825	≤ 11.00	-0.17
5700.0	5.445	6.922	6.130	--	10.979	≤ 11.00	-0.02

Traceability to Industry Recognized Test Methodologies

Work Instruction:	WI-03 MEASURING RF SPECTRUM MASK
Measurement Uncertainty:	±2.81 dB

This test report may be reproduced in full only. The document may only be updated by MiCOM Labs personnel. Any changes will be noted in the Document History section of the report.



Title: APIN0114, APIN0115 802.11a/b/g/n
To: FCC 47 CFR Part 15.407 & IC RSS-210
Serial #: ARUB149-U4 Rev A
Issue Date: 5th August 2013
Page: 44 of 257

Equipment Configuration for Peak Power Spectral Density

Variant:	802.11n HT-20	Duty Cycle (%):	100
Data Rate:	6.5 MBit/s	Antenna Gain (dBi):	Not Applicable
Modulation:	OFDM	Beam Forming Gain (Y):	Not Applicable
TPC:	Not Applicable		
Engineering Test Notes:			

Test Measurement Results

Test Frequency	Measured Power Spectral Density (dBm)				Calculated Total Power Spectral Density (dBm)	Limit	Margin
	Port(s)						
MHz	a	b	c	d	Σ Port(s)	dBm	dB
5260.0	5.565	5.901	7.010	--	10.975	≤ 11.00	-0.03
5300.0	5.837	5.434	6.264	--	10.629	≤ 11.00	-0.37
5320.0	5.740	5.538	6.062	--	10.557	≤ 11.00	-0.44

Traceability to Industry Recognized Test Methodologies

Work Instruction:	WI-03 MEASURING RF SPECTRUM MASK
Measurement Uncertainty:	±2.81 dB

Equipment Configuration for Peak Power Spectral Density

Variant:	802.11n HT-20	Duty Cycle (%):	100
Data Rate:	6.5 MBit/s	Antenna Gain (dBi):	Not Applicable
Modulation:	OFDM	Beam Forming Gain (Y):	Not Applicable
TPC:	Not Applicable		
Engineering Test Notes:			

Test Measurement Results

Test Frequency	Measured Power Spectral Density (dBm)				Calculated Total Power Spectral Density (dBm)	Limit	Margin
	Port(s)						
MHz	a	b	c	d	Σ Port(s)	dBm	dB
5500.0	5.612	5.973	6.396	--	10.777	≤ 11.00	-0.22
5580.0	4.984	6.529	6.806	--	10.948	≤ 11.00	-0.05
5700.0	5.056	7.002	6.201	--	10.930	≤ 11.00	-0.07

Traceability to Industry Recognized Test Methodologies

Work Instruction:	WI-03 MEASURING RF SPECTRUM MASK
Measurement Uncertainty:	±2.81 dB

This test report may be reproduced in full only. The document may only be updated by MiCOM Labs personnel. Any changes will be noted in the Document History section of the report.



Title: APIN0114, APIN0115 802.11a/b/g/n
To: FCC 47 CFR Part 15.407 & IC RSS-210
Serial #: ARUB149-U4 Rev A
Issue Date: 5th August 2013
Page: 45 of 257

Equipment Configuration for Peak Power Spectral Density

Variant:	802.11n HT-40	Duty Cycle (%):	100
Data Rate:	13.5 MBit/s	Antenna Gain (dBi):	Not Applicable
Modulation:	OFDM	Beam Forming Gain (Y):	Not Applicable
TPC:	Not Applicable		
Engineering Test Notes:			

Test Measurement Results

Test Frequency	Measured Power Spectral Density (dBm)				Calculated Total Power Spectral Density (dBm)	Limit	Margin
	Port(s)						
MHz	a	b	c	d	Σ Port(s)	dBm	dB
5270.0	3.342	3.990	5.058	--	8.960	≤ 11.00	-2.04
5310.0	4.253	4.326	4.787	--	9.233	≤ 11.00	-1.77

Traceability to Industry Recognized Test Methodologies

Work Instruction:	WI-03 MEASURING RF SPECTRUM MASK
Measurement Uncertainty:	±2.81 dB

Equipment Configuration for Peak Power Spectral Density

Variant:	802.11n HT-40	Duty Cycle (%):	100
Data Rate:	13.5 MBit/s	Antenna Gain (dBi):	Not Applicable
Modulation:	OFDM	Beam Forming Gain (Y):	Not Applicable
TPC:	Not Applicable		
Engineering Test Notes:			

Test Measurement Results

Test Frequency	Measured Power Spectral Density (dBm)				Calculated Total Power Spectral Density (dBm)	Limit	Margin
	Port(s)						
MHz	a	b	c	d	Σ Port(s)	dBm	dB
5510.0	2.909	3.612	4.103	--	8.340	≤ 11.00	-2.66
5550.0	2.669	4.380	4.129	--	8.560	≤ 11.00	-2.44
5670.0	2.507	4.394	3.930	--	8.453	≤ 11.00	-2.55

Traceability to Industry Recognized Test Methodologies

Work Instruction:	WI-03 MEASURING RF SPECTRUM MASK
Measurement Uncertainty:	±2.81 dB

This test report may be reproduced in full only. The document may only be updated by MiCOM Labs personnel. Any changes will be noted in the Document History section of the report.



Specification

FCC, Part 15 §15.407 (a)(1), (a)(2)

5150 – 5250 MHz

(a)(1) The peak power spectral density shall not exceed +4 dBm in any 1 megahertz band.

5250 – 5350 MHz & 5470 – 5725 MHz

(a)(2) The peak power spectral density shall not exceed +11 dBm in any 1 megahertz band.

Industry Canada RSS-210 § A9.2(1), A9.2(2)

5150 – 5250 MHz

§ **A9.2(1)** The eirp spectral density shall not exceed +10 dBm in any 1 MHz band

5250 – 5350 MHz & 5470 – 5725 MHz

§ **A9.2(2)** The power spectral density shall not exceed +11 dBm in any 1 MHz band

Traceability

Test Equipment Used

0158, 0287, 0252, 0313, 0314, 0070, 0116, 0117
--



Title: APIN0114, APIN0115 802.11a/b/g/n
To: FCC 47 CFR Part 15.407 & IC RSS-210
Serial #: ARUB149-U4 Rev A
Issue Date: 5th August 2013
Page: 47 of 257

6.1.1.4. Peak Excursion Ratio

Conducted Test Conditions for Peak Excursion Ratio			
Standard:	FCC CFR 47:15.407	Ambient Temp. (°C):	24.0 - 27.5
Test Heading:	Peak Excursion Ratio	Rel. Humidity (%):	32 - 45
Standard Section(s):	15.407 (a)(6)	Pressure (mBars):	999 - 1001
Reference Document(s):	KDB 789033 - D01 DTS General UNII Test Procedures v01		
Test Procedure for Peak Excursion Ratio			
<p>Compliance with the peak excursion requirement is demonstrated by confirming the ratio of the maximum of the peak-hold spectrum to the maximum of the average spectrum during continuous transmission. Section F) of KDB 789033 was used in order to prove compliance. This is a conducted measurement using a spectrum analyzer using dual traces. Peak Excursion Ratio is the difference in amplitude (dB) between both traces; The following identifies two spectrum traces on the same plot. <u>Trace 1</u> is the max hold Peak detector, and <u>Trace 2</u> is the recalled trace data from Peak Power Spectral Density measurements. Each frequency and operational mode is recalled in order to prove compliance.</p>			

This test report may be reproduced in full only. The document may only be updated by MiCOM Labs personnel. Any changes will be noted in the Document History section of the report.



Title: APIN0114, APIN0115 802.11a/b/g/n
To: FCC 47 CFR Part 15.407 & IC RSS-210
Serial #: ARUB149-U4 Rev A
Issue Date: 5th August 2013
Page: 48 of 257

Equipment Configuration for Peak Excursion Ratio

Variant:	802.11a	Duty Cycle (%):	100
Data Rate:	6 MBit/s	Antenna Gain (dBi):	Not Applicable
Modulation:	OFDM	Beam Forming Gain (Y):	Not Applicable
TPC:	Not Applicable		
Engineering Test Notes:			

Test Measurement Results

Test Frequency MHz	Measured Peak Excursion (dB) Port(s)				Ratio (dB)		Limit dB	Lowest Margin MHz
	a	b	c	d	Highest	Lowest		
5260.0	8.66	--	--	--	8.66	8.66	13.0	-4.34

Traceability to Industry Recognized Test Methodologies

Work Instruction:	WI-03 MEASURING RF SPECTRUM MASK
Measurement Uncertainty:	±2.81 dB

Equipment Configuration for Peak Excursion Ratio

Variant:	802.11a	Duty Cycle (%):	100
Data Rate:	6 MBit/s	Antenna Gain (dBi):	Not Applicable
Modulation:	OFDM	Beam Forming Gain (Y):	Not Applicable
TPC:	Not Applicable		
Engineering Test Notes:			

Test Measurement Results

Test Frequency MHz	Measured Peak Excursion (dB) Port(s)				Ratio (dB)		Limit dB	Lowest Margin MHz
	a	b	c	d	Highest	Lowest		
5500.0	9.00	--	--	--	9.00	9.00	13.0	-4.00

Traceability to Industry Recognized Test Methodologies

Work Instruction:	WI-03 MEASURING RF SPECTRUM MASK
Measurement Uncertainty:	±2.81 dB

This test report may be reproduced in full only. The document may only be updated by MiCOM Labs personnel. Any changes will be noted in the Document History section of the report.



Title: APIN0114, APIN0115 802.11a/b/g/n
To: FCC 47 CFR Part 15.407 & IC RSS-210
Serial #: ARUB149-U4 Rev A
Issue Date: 5th August 2013
Page: 49 of 257

Equipment Configuration for Peak Excursion Ratio

Variant:	802.11n HT-20	Duty Cycle (%):	100
Data Rate:	6.5 MBit/s	Antenna Gain (dBi):	Not Applicable
Modulation:	OFDM	Beam Forming Gain (Y):	Not Applicable
TPC:	Not Applicable		
Engineering Test Notes:			

Test Measurement Results

Test Frequency MHz	Measured Peak Excursion (dB) Port(s)				Ratio (dB)		Limit dB	Lowest Margin MHz
	a	b	c	d	Highest	Lowest		
5260.0	8.47	--	--	--	8.47	8.47	13.0	-4.53

Traceability to Industry Recognized Test Methodologies

Work Instruction:	WI-03 MEASURING RF SPECTRUM MASK
Measurement Uncertainty:	±2.81 dB

Equipment Configuration for Peak Excursion Ratio

Variant:	802.11n HT-20	Duty Cycle (%):	100
Data Rate:	6.5 MBit/s	Antenna Gain (dBi):	Not Applicable
Modulation:	OFDM	Beam Forming Gain (Y):	Not Applicable
TPC:	Not Applicable		
Engineering Test Notes:			

Test Measurement Results

Test Frequency MHz	Measured Peak Excursion (dB) Port(s)				Ratio (dB)		Limit dB	Lowest Margin MHz
	a	b	c	d	Highest	Lowest		
5500.0	9.12	--	--	--	9.12	9.12	13.0	-3.88

Traceability to Industry Recognized Test Methodologies

Work Instruction:	WI-03 MEASURING RF SPECTRUM MASK
Measurement Uncertainty:	±2.81 dB

This test report may be reproduced in full only. The document may only be updated by MiCOM Labs personnel. Any changes will be noted in the Document History section of the report.



Title: APIN0114, APIN0115 802.11a/b/g/n
To: FCC 47 CFR Part 15.407 & IC RSS-210
Serial #: ARUB149-U4 Rev A
Issue Date: 5th August 2013
Page: 50 of 257

Equipment Configuration for Peak Excursion Ratio

Variant:	802.11n HT-40	Duty Cycle (%):	100
Data Rate:	13.5 MBit/s	Antenna Gain (dBi):	Not Applicable
Modulation:	OFDM	Beam Forming Gain (Y):	Not Applicable
TPC:	Not Applicable		
Engineering Test Notes:			

Test Measurement Results

Test Frequency MHz	Measured Peak Excursion (dB) Port(s)				Ratio (dB)		Limit dB	Lowest Margin MHz
	a	b	c	d	Highest	Lowest		
5270.0	9.44	--	--	--	9.44	9.44	13.0	-3.56

Traceability to Industry Recognized Test Methodologies

Work Instruction:	WI-03 MEASURING RF SPECTRUM MASK
Measurement Uncertainty:	±2.81 dB

Equipment Configuration for Peak Excursion Ratio

Variant:	802.11n HT-40	Duty Cycle (%):	100
Data Rate:	13.5 MBit/s	Antenna Gain (dBi):	Not Applicable
Modulation:	OFDM	Beam Forming Gain (Y):	Not Applicable
TPC:	Not Applicable		
Engineering Test Notes:			

Test Measurement Results

Test Frequency MHz	Measured Peak Excursion (dB) Port(s)				Ratio (dB)		Limit dB	Lowest Margin MHz
	a	b	c	d	Highest	Lowest		
5510.0	9.85	--	--	--	9.85	9.85	13.0	-3.15

Traceability to Industry Recognized Test Methodologies

Work Instruction:	WI-03 MEASURING RF SPECTRUM MASK
Measurement Uncertainty:	±2.81 dB

This test report may be reproduced in full only. The document may only be updated by MiCOM Labs personnel. Any changes will be noted in the Document History section of the report.



Title: APIN0114, APIN0115 802.11a/b/g/n
To: FCC 47 CFR Part 15.407 & IC RSS-210
Serial #: ARUB149-U4 Rev A
Issue Date: 5th August 2013
Page: 51 of 257

Specification

Limits

§15.407 (a)(6) The ratio of the peak excursion of the modulation envelope (measured using a peak hold function) to the peak transmit power (measured as specified in this paragraph) shall not exceed 13dB across any 1MHz bandwidth or the emission bandwidth whichever is less

Traceability

Test Equipment Used

0158, 0287, 0252, 0313, 0314, 0070, 0116, 0117
--

This test report may be reproduced in full only. The document may only be updated by MiCOM Labs personnel. Any changes will be noted in the Document History section of the report.



Title: APIN0114, APIN0115 802.11a/b/g/n
To: FCC 47 CFR Part 15.407 & IC RSS-210
Serial #: ARUB149-U4 Rev A
Issue Date: 5th August 2013
Page: 52 of 257

6.1.1.5. Frequency Stability

FCC, Part 15 Subpart C §15.407(g)
Industry Canada RSS-210 §2.1

Test Procedure

The manufacturer of the equipment is responsible for ensuring that the frequency stability is such that emissions are always maintained within the band of operation under all conditions.

Manufacturer Declaration

The frequency stability of the reference oscillator sets the frequency stability of the RF transceiver signals. Therefore all of the RF signals should have ± 20 ppm stability.

This stability accounts for room temp tolerance of the crystal oscillator circuit, frequency variation across temperature, and crystal ageing.

± 20 ppm at 5.250 GHz translates to a maximum frequency shift of ± 105 KHz. As the edge of the channels is at least one MHz from either of the band edges, ± 105 KHz is more than sufficient to guarantee that the intentional emission will remain in the band over the entire operating range of the EUT.

Specification

Limits

§15.407 (g) Manufacturers of U-NII devices are responsible for ensuring frequency stability such that an emission is maintained within the band of operation under all conditions of normal operation as specified in the user's manual.

This test report may be reproduced in full only. The document may only be updated by MiCOM Labs personnel. Any changes will be noted in the Document History section of the report.



6.1.2. Radiated Emission Testing

FCC, Part 15 Subpart C §15.407(b)(2), §15.205(a)/15.209(a)
Industry Canada RSS-210 §A9.3(2); §2.2; §2.6; RSS-Gen §4.7

Test Procedure

Testing was performed in a 3-meter anechoic chamber. Preliminary radiated emissions were measured on every azimuth and with the receiving antenna in both horizontal and vertical polarizations. Preliminary emissions were recorded with in Spectrum Analyzer mode, using a maximum peak detector while in peak hold mode. Depending on the frequency band spanned a notch filter and/or waveguide filter was used to remove the fundamental frequency.

Emissions nearest the limits were chosen for maximization and formal measurement using a CISPR compliant receiver. Emissions above 1000 MHz are measured utilizing a CISPR compliant average detector with a tuned receiver, using a bandwidth of 1 MHz. Emissions from 30 MHz – 1000 MHz are measured utilizing a CISPR compliant quasi-peak detector with a tuned receiver, using a bandwidth of 120 kHz. Only the highest emissions relative to the limit are listed.

Field Strength Calculation

The field strength is calculated by adding the Antenna Factor and Cable Loss, and subtracting Amplifier Gain from the measured reading. All factors are included in the reported data.

$$FS = R + AF + CORR - FO$$

FS = Field Strength

R = Measured Spectrum analyzer Input Amplitude

AF = Antenna Factor

$$CORR = \text{Correction Factor} = CL - AG + NFL$$

CL = Cable Loss

AG = Amplifier Gain

FO = Distance Falloff Factor

NFL = Notch Filter Loss or Waveguide Loss

Field Strength Calculation Example:

Given receiver input reading of 51.5 dB μ V; Antenna Factor of 8.5 dB; Cable Loss of 1.3 dB; Falloff Factor of 0 dB, an Amplifier Gain of 26 dB and Notch Filter Loss of 1 dB. The Field Strength of the measured emission is:

$$FS = 51.5 + 8.5 + 1.3 - 26.0 + 1 = 36.3 \text{ dB}\mu\text{V/m}$$

Conversion between dB μ V/m (or dB μ V) and μ V/m (or μ V) are done as:

$$\text{Level (dB}\mu\text{V/m)} = 20 * \text{Log (level (\mu\text{V/m}))}$$

$$40 \text{ dB}\mu\text{V/m} = 100 \mu\text{V/m}$$

$$48 \text{ dB}\mu\text{V/m} = 250 \mu\text{V/m}$$

This test report may be reproduced in full only. The document may only be updated by MiCOM Labs personnel. Any changes will be noted in the Document History section of the report.



Title: APIN0114, APIN0115 802.11a/b/g/n
To: FCC 47 CFR Part 15.407 & IC RSS-210
Serial #: ARUB149-U4 Rev A
Issue Date: 5th August 2013
Page: 54 of 257

The following formula is used to convert the equipment isotropic radiated power (eirp) to field strength (dB μ V/m);

$$E = 1000000 \times \sqrt{30P} / 3 \mu\text{V/m}$$

where P is the EIRP in Watts

Therefore: -27 dBm/MHz = 68.23 dB μ V/m

Note: The data in this Section identifies that the EUT is in compliance with the -27dBm/MHz EIRP limit (68.23 dB μ V/m) for out of band emissions. All out of band emissions are less than 68.23 dB μ V/m.

This test report may be reproduced in full only. The document may only be updated by MiCOM Labs personnel. Any changes will be noted in the Document History section of the report.



Title: APIN0114, APIN0115 802.11a/b/g/n
To: FCC 47 CFR Part 15.407 & IC RSS-210
Serial #: ARUB149-U4 Rev A
Issue Date: 5th August 2013
Page: 55 of 257

Specification

Radiated Spurious Emissions

15.407 (b)(2). All emissions outside of the 5,150-5,350MHz band shall not exceed an EIRP of -27dBm/MHz.

FCC §15.205 (a) Except as shown in paragraph (d) of 15.205 (a), only spurious emissions are permitted in any of the frequency bands listed.

FCC §15.205 (a) Except as shown in paragraphs (d) and (e) of this section, the field strength of emissions appearing within these frequency bands shall not exceed the limits shown in Section §15.209. At frequencies equal to or less than 1000 MHz, compliance with the limits in Section 15.209 shall be demonstrated using measurement instrumentation employing a CISPR quasi-peak detector. Above 1000 MHz, compliance with the emission limits in Section 15.209 shall be demonstrated based on the average value of the measured emissions. The provisions in Section 15.35 apply to these measurements.

FCC §15.209 (a) Except as provided elsewhere in this subpart, the emissions from an intentional radiator shall not exceed the field strength levels specified in the following table.

RSS-210 §A9.3(2) For transmitters operating in the 5250-5350 MHz band, all emissions outside the 5150-5350 MHz band shall not exceed -27 dBm/MHz e.i.r.p. Devices operating in the 5250-5350 MHz band that generate emissions in the 5150-5250 MHz band shall not exceed out of band emission limit of 27 dBm/MHz e.i.r.p. in the 5150-5250 MHz band in order to operate indoor/outdoor, or alternatively shall comply with the spectral power density for operation within the 5150-5250 MHz band and shall be labeled "for indoor use only".

RSS-Gen §4.7 The search for unwanted emissions shall be from the lowest frequency internally generated or used in the device (local oscillator, intermediate of carrier frequency), or from 30 MHz, whichever is the lowest frequency, to the 5th harmonic of the highest frequency generated without exceeding 40 GHz.

RSS-Gen §6 Receiver Spurious Emission Standard

If a radiated measurement is made, all spurious emissions shall comply with the limits of the following Table. The resolution bandwidth of the spectrum analyzer shall be 100 kHz for spurious emission measurements below 1.0 GHz and 1.0 MHz for measurements above 1.0 GHz

This test report may be reproduced in full only. The document may only be updated by MiCOM Labs personnel. Any changes will be noted in the Document History section of the report.



Title: APIN0114, APIN0115 802.11a/b/g/n
To: FCC 47 CFR Part 15.407 & IC RSS-210
Serial #: ARUB149-U4 Rev A
Issue Date: 5th August 2013
Page: 56 of 257

Table 1: FCC 15.209 Spurious Emissions Limits

Frequency (MHz)	Field Strength ($\mu\text{V/m}$)	Field Strength ($\text{dB}\mu\text{V/m}$)	Measurement Distance (meters)
30-88	100	40.0	3
88-216	150	43.5	3
216-960	200	46.0	3
Above 960	500	54.0	3

Traceability:

Test Equipment Used
0088, 0158, 0134, 0304, 0311, 0315, 0310, 0312

This test report may be reproduced in full only. The document may only be updated by MiCOM Labs personnel. Any changes will be noted in the Document History section of the report.



Title: APIN0114, APIN0115 802.11a/b/g/n
To: FCC 47 CFR Part 15.407 & IC RSS-210
Serial #: ARUB149-U4 Rev A
Issue Date: 5th August 2013
Page: 57 of 257

6.1.2.1. Integral Antenna – Spurious Emissions

Test Freq.	5260 MHz	Engineer	SB
Variant	802.11a; 6 Mbs	Temp (°C)	24
Freq. Range	1000 MHz - 18000 MHz	Rel. Hum.(%)	30
Power Setting	18	Press. (mBars)	1010
Antenna	integral	Duty Cycle (%)	100
Test Notes 1			
Test Notes 2			

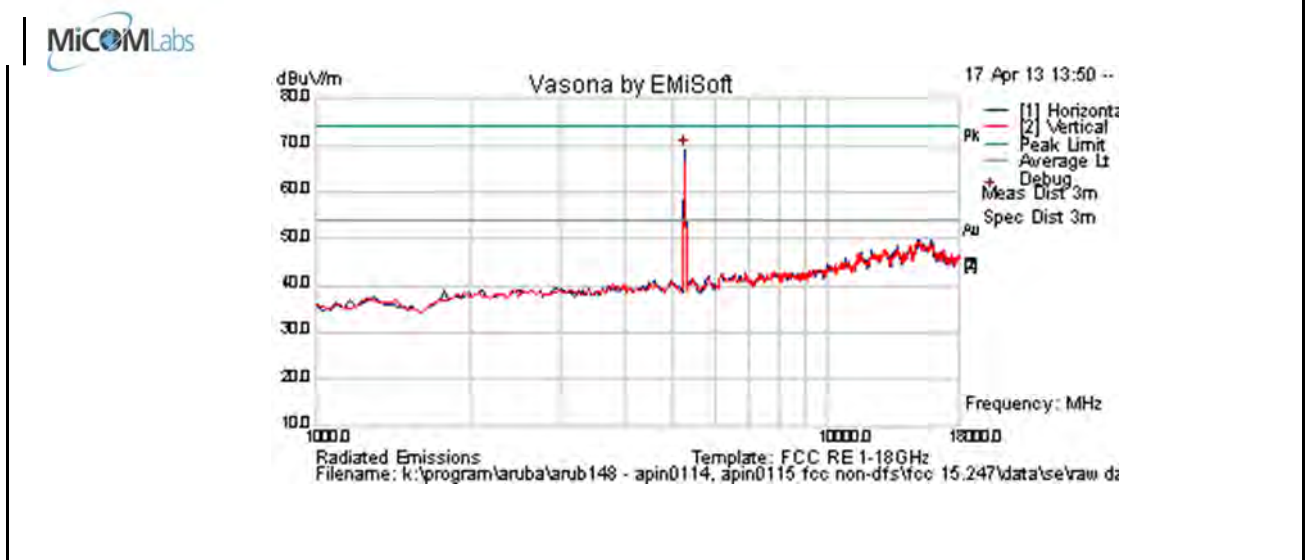

Formally measured emission peaks

Frequency MHz	Raw dBuV	Cable Loss	AF dB	Level dBuV/m	Measurement Type	PoI	Hgt cm	Azt Deg	Limit dBuV/m	Margin dB	Pass /Fail	Comments
5258.517	74.1	4.8	-9.7	69.2	Peak [Scan]	H	150	0				FUND
Legend: TX = Transmitter Emissions; DIG = Digital Emissions; FUND = Fundamental; WB = Wideband Emission NRB = Non-Restricted Band. Limit = 68.23 dBuV/m; RB = Restricted Band. Limits per 15.205												

This test report may be reproduced in full only. The document may only be updated by MiCOM Labs personnel. Any changes will be noted in the Document History section of the report.



Title: APIN0114, APIN0115 802.11a/b/g/n
To: FCC 47 CFR Part 15.407 & IC RSS-210
Serial #: ARUB149-U4 Rev A
Issue Date: 5th August 2013
Page: 58 of 257

Test Freq.	5300 MHz	Engineer	SB
Variant	802.11a; 6 Mbs	Temp (°C)	24
Freq. Range	1000 MHz - 18000 MHz	Rel. Hum.(%)	30
Power Setting	18	Press. (mBars)	1010
Antenna	integral	Duty Cycle (%)	100
Test Notes 1			
Test Notes 2			

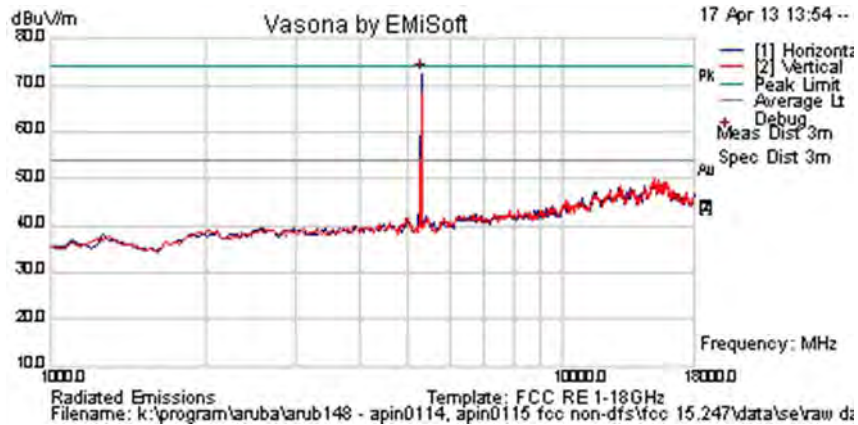

Formally measured emission peaks

Frequency MHz	Raw dBuV	Cable Loss	AF dB	Level dBuV/m	Measurement Type	Pol	Hgt cm	Azt Deg	Limit dBuV/m	Margin dB	Pass /Fail	Comments
5292.585	77.3	4.8	-9.6	72.5	Peak [Scan]	H	100	0				FUND

Legend: TX = Transmitter Emissions; DIG = Digital Emissions; FUND = Fundamental; WB = Wideband Emission
 NRB = Non-Restricted Band. Limit = 68.23 dBuV/m; RB = Restricted Band. Limits per 15.205

This test report may be reproduced in full only. The document may only be updated by MiCOM Labs personnel. Any changes will be noted in the Document History section of the report.



Title: APIN0114, APIN0115 802.11a/b/g/n
To: FCC 47 CFR Part 15.407 & IC RSS-210
Serial #: ARUB149-U4 Rev A
Issue Date: 5th August 2013
Page: 59 of 257

Test Freq.	5320 MHz	Engineer	SB
Variant	802.11a; 6 Mbs	Temp (°C)	24
Freq. Range	1000 MHz - 18000 MHz	Rel. Hum.(%)	30
Power Setting	18	Press. (mBars)	1010
Antenna	integral	Duty Cycle (%)	100
Test Notes 1			
Test Notes 2			

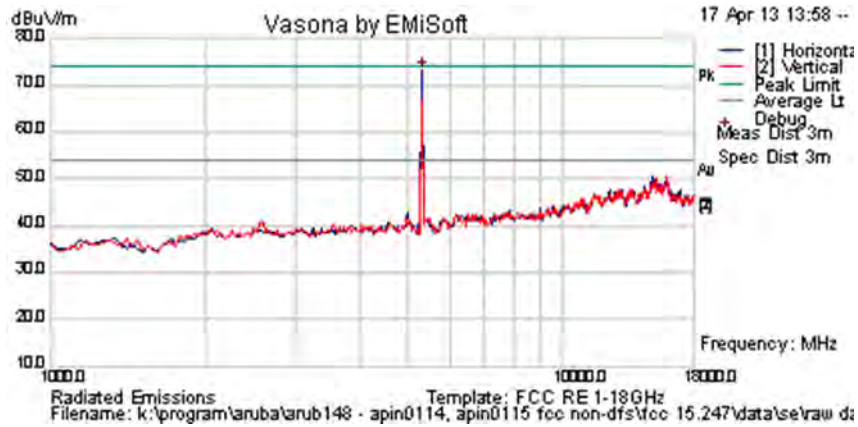

Formally measured emission peaks

Frequency MHz	Raw dBuV	Cable Loss	AF dB	Level dBuV/m	Measurement Type	Pol	Hgt cm	Azt Deg	Limit dBuV/m	Margin dB	Pass /Fail	Comments
5326.653	77.9	4.9	-9.5	73.3	Peak [Scan]	H	100	0				FUND

Legend: TX = Transmitter Emissions; DIG = Digital Emissions; FUND = Fundamental; WB = Wideband Emission
 NRB = Non-Restricted Band. Limit = 68.23 dBuV/m; RB = Restricted Band. Limits per 15.205

This test report may be reproduced in full only. The document may only be updated by MiCOM Labs personnel. Any changes will be noted in the Document History section of the report.



Title: APIN0114, APIN0115 802.11a/b/g/n
To: FCC 47 CFR Part 15.407 & IC RSS-210
Serial #: ARUB149-U4 Rev A
Issue Date: 5th August 2013
Page: 60 of 257

Test Freq.	5500 MHz	Engineer	SB
Variant	802.11a; 6 Mbs	Temp (°C)	24
Freq. Range	1000 MHz - 18000 MHz	Rel. Hum.(%)	30
Power Setting	18	Press. (mBars)	1010
Antenna	integral	Duty Cycle (%)	100
Test Notes 1			
Test Notes 2			

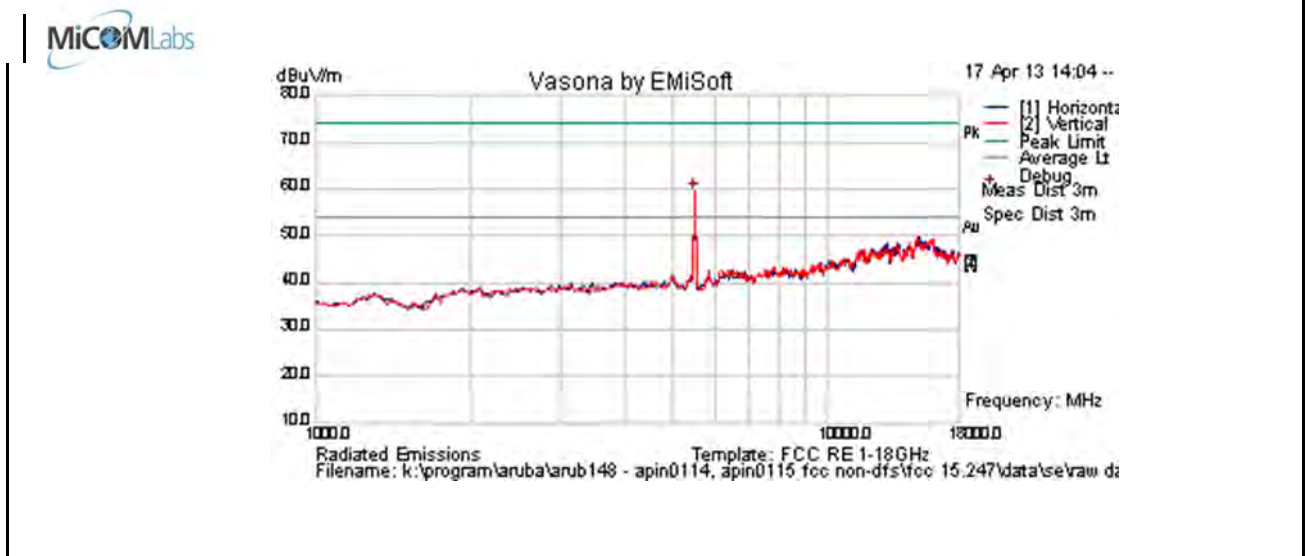

Formally measured emission peaks												
Frequency MHz	Raw dBuV	Cable Loss	AF dB	Level dBuV/m	Measurement Type	Pol	Hgt cm	Azt Deg	Limit dBuV/m	Margin dB	Pass /Fail	Comments
5496.994	64.0	5.0	-9.6	59.4	Peak [Scan]	V	100	0				FUND
Legend: TX = Transmitter Emissions; DIG = Digital Emissions; FUND = Fundamental; WB = Wideband Emission NRB = Non-Restricted Band. Limit = 68.23 dBuV/m; RB = Restricted Band. Limits per 15.205												

This test report may be reproduced in full only. The document may only be updated by MiCOM Labs personnel. Any changes will be noted in the Document History section of the report.



Title: APIN0114, APIN0115 802.11a/b/g/n
To: FCC 47 CFR Part 15.407 & IC RSS-210
Serial #: ARUB149-U4 Rev A
Issue Date: 5th August 2013
Page: 61 of 257

Test Freq.	5580 MHz	Engineer	SB
Variant	802.11a; 6 Mbs	Temp (°C)	24
Freq. Range	1000 MHz - 18000 MHz	Rel. Hum.(%)	30
Power Setting	18	Press. (mBars)	1010
Antenna	integral	Duty Cycle (%)	100
Test Notes 1			
Test Notes 2			

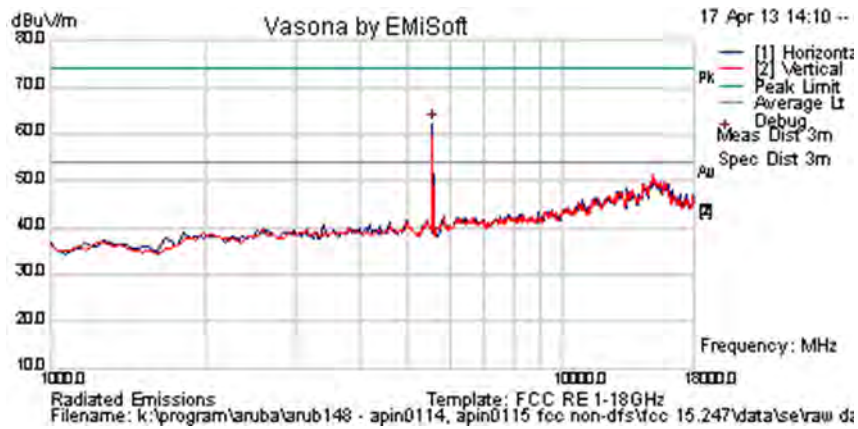

Formally measured emission peaks

Frequency MHz	Raw dBuV	Cable Loss	AF dB	Level dBuV/m	Measurement Type	Pol	Hgt cm	Azt Deg	Limit dBuV/m	Margin dB	Pass /Fail	Comments
5565.130	66.9	4.9	-9.7	62.2	Peak [Scan]	H	150	0				FUND
Legend: TX = Transmitter Emissions; DIG = Digital Emissions; FUND = Fundamental; WB = Wideband Emission NRB = Non-Restricted Band. Limit = 68.23 dBuV/m; RB = Restricted Band. Limits per 15.205												

This test report may be reproduced in full only. The document may only be updated by MiCOM Labs personnel. Any changes will be noted in the Document History section of the report.



Title: APIN0114, APIN0115 802.11a/b/g/n
To: FCC 47 CFR Part 15.407 & IC RSS-210
Serial #: ARUB149-U4 Rev A
Issue Date: 5th August 2013
Page: 62 of 257

Test Freq.	5700 MHz	Engineer	SB
Variant	802.11a; 6 Mbs	Temp (°C)	24
Freq. Range	1000 MHz - 18000 MHz	Rel. Hum.(%)	30
Power Setting	18	Press. (mBars)	1010
Antenna	integral	Duty Cycle (%)	100
Test Notes 1			
Test Notes 2			

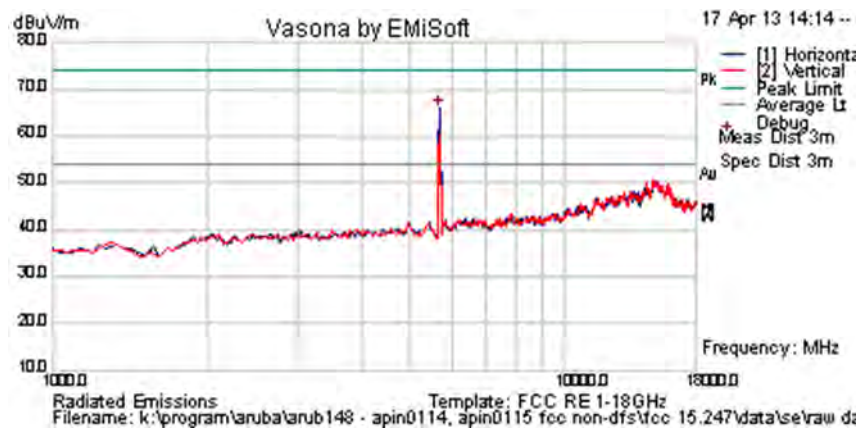

Formally measured emission peaks

Frequency MHz	Raw dBuV	Cable Loss	AF dB	Level dBuV/m	Measurement Type	Pol	Hgt cm	Azt Deg	Limit dBuV/m	Margin dB	Pass /Fail	Comments
5701.403	70.5	5.0	-9.6	65.9	Peak [Scan]	H	150	0				FUND
Legend: TX = Transmitter Emissions; DIG = Digital Emissions; FUND = Fundamental; WB = Wideband Emission NRB = Non-Restricted Band. Limit = 68.23 dBuV/m; RB = Restricted Band. Limits per 15.205												

This test report may be reproduced in full only. The document may only be updated by MiCOM Labs personnel. Any changes will be noted in the Document History section of the report.



6.1.2.2. ANT-1B – Spurious Emissions

Test Freq.	5260 MHz	Engineer	SB
Variants	802.11a; 6 Mbs	Temp (°C)	24
Freq. Range	1000 MHz - 18000 MHz	Rel. Hum.(%)	30
Power Setting	15.0	Press. (mBars)	1010
Antenna	AP-ANT-1B	Duty Cycle (%)	100
Test Notes 1			
Test Notes 2			

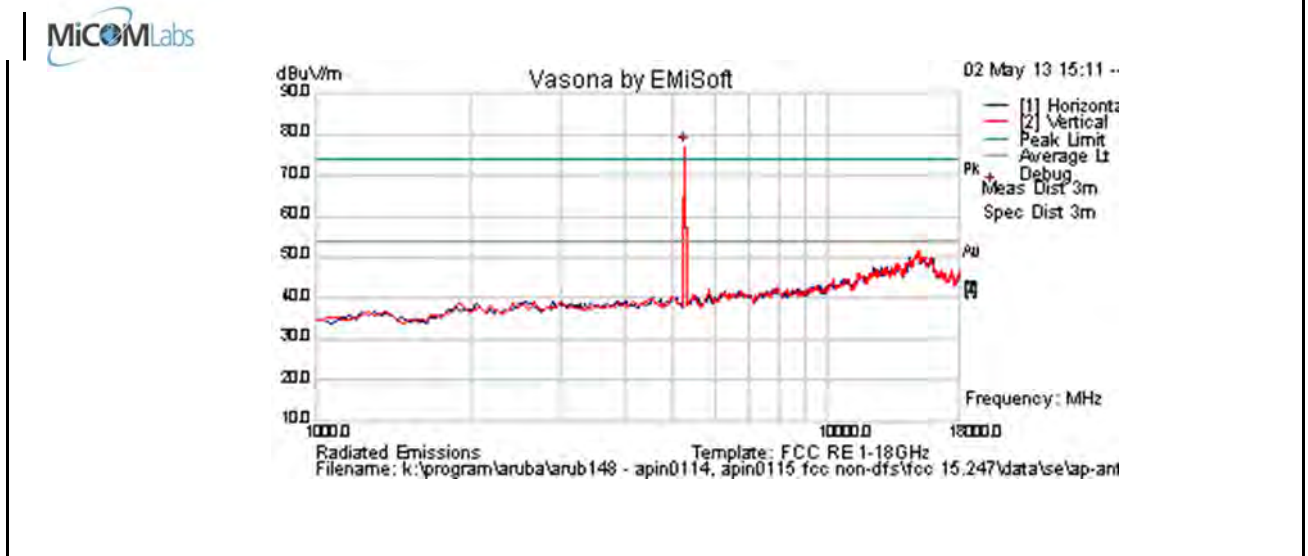

Formally measured emission peaks

Frequency MHz	Raw dBuV	Cable Loss	AF dB	Level dBuV/m	Measurement Type	Pol	Hgt cm	Azt Deg	Limit dBuV/m	Margin dB	Pass /Fail	Comments
5258.517	82.0	4.8	-9.7	77.0	Peak [Scan]	V	100	0				FUND
Legend: TX = Transmitter Emissions; DIG = Digital Emissions; FUND = Fundamental; WB = Wideband Emission NRB = Non-Restricted Band. Limit = 68.23 dBuV/m; RB = Restricted Band. Limits per 15.205												

This test report may be reproduced in full only. The document may only be updated by MiCOM Labs personnel. Any changes will be noted in the Document History section of the report.



Title: APIN0114, APIN0115 802.11a/b/g/n
To: FCC 47 CFR Part 15.407 & IC RSS-210
Serial #: ARUB149-U4 Rev A
Issue Date: 5th August 2013
Page: 64 of 257

Test Freq.	5300 MHz	Engineer	SB
Variant	802.11a; 6 Mbs	Temp (°C)	24
Freq. Range	1000 MHz - 18000 MHz	Rel. Hum.(%)	30
Power Setting	15.0	Press. (mBars)	1010
Antenna	AP-ANT-1B	Duty Cycle (%)	100
Test Notes 1			
Test Notes 2			

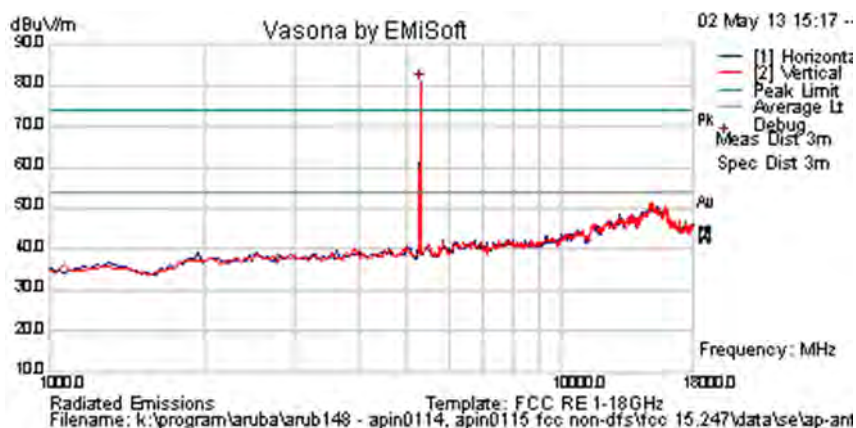

Formally measured emission peaks

Frequency MHz	Raw dBuV	Cable Loss	AF dB	Level dBuV/m	Measurement Type	Pol	Hgt cm	Azt Deg	Limit dBuV/m	Margin dB	Pass /Fail	Comments
5292.585	74.0	4.8	-9.6	69.2	Peak [Scan]	V	100	0				FUND
Legend: TX = Transmitter Emissions; DIG = Digital Emissions; FUND = Fundamental; WB = Wideband Emission NRB = Non-Restricted Band. Limit = 68.23 dBuV/m; RB = Restricted Band. Limits per 15.205												

This test report may be reproduced in full only. The document may only be updated by MiCOM Labs personnel. Any changes will be noted in the Document History section of the report.



Title: APIN0114, APIN0115 802.11a/b/g/n
To: FCC 47 CFR Part 15.407 & IC RSS-210
Serial #: ARUB149-U4 Rev A
Issue Date: 5th August 2013
Page: 65 of 257

Test Freq.	5320 MHz	Engineer	SB
Variant	802.11a; 6 Mbs	Temp (°C)	24
Freq. Range	1000 MHz - 18000 MHz	Rel. Hum.(%)	30
Power Setting	15.0	Press. (mBars)	1010
Antenna	AP-ANT-1B	Duty Cycle (%)	100
Test Notes 1			
Test Notes 2			

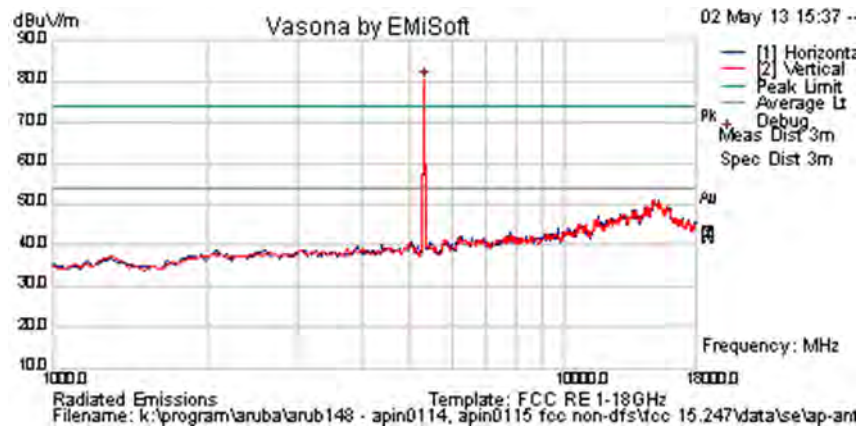

Formally measured emission peaks

Frequency MHz	Raw dBuV	Cable Loss	AF dB	Level dBuV/m	Measurement Type	Pol	Hgt cm	Azt Deg	Limit dBuV/m	Margin dB	Pass /Fail	Comments
5326.653	84.9	4.9	-9.5	80.3	Peak [Scan]	V	100	0				FUND
Legend: TX = Transmitter Emissions; DIG = Digital Emissions; FUND = Fundamental; WB = Wideband Emission NRB = Non-Restricted Band. Limit = 68.23 dBuV/m; RB = Restricted Band. Limits per 15.205												

This test report may be reproduced in full only. The document may only be updated by MiCOM Labs personnel. Any changes will be noted in the Document History section of the report.



Title: APIN0114, APIN0115 802.11a/b/g/n
To: FCC 47 CFR Part 15.407 & IC RSS-210
Serial #: ARUB149-U4 Rev A
Issue Date: 5th August 2013
Page: 66 of 257

Test Freq.	5500 MHz	Engineer	SB
Variant	802.11a; 6 Mbs	Temp (°C)	24
Freq. Range	1000 MHz - 18000 MHz	Rel. Hum.(%)	30
Power Setting	17.0	Press. (mBars)	1010
Antenna	AP-ANT-1B	Duty Cycle (%)	100
Test Notes 1			
Test Notes 2			

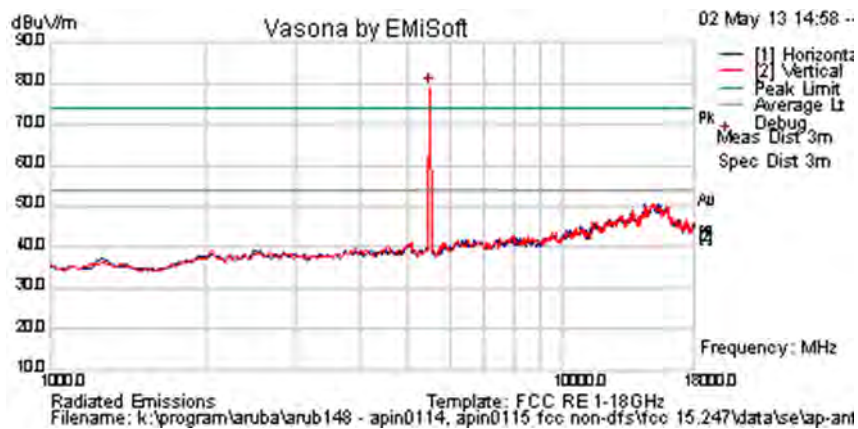

Formally measured emission peaks

Frequency MHz	Raw dBuV	Cable Loss	AF dB	Level dBuV/m	Measurement Type	Pol	Hgt cm	Azt Deg	Limit dBuV/m	Margin dB	Pass /Fail	Comments
5496.994	83.7	5.0	-9.6	79.1	Peak [Scan]	V	100	0				FUND
Legend: TX = Transmitter Emissions; DIG = Digital Emissions; FUND = Fundamental; WB = Wideband Emission NRB = Non-Restricted Band. Limit = 68.23 dBuV/m; RB = Restricted Band. Limits per 15.205												

This test report may be reproduced in full only. The document may only be updated by MiCOM Labs personnel. Any changes will be noted in the Document History section of the report.



Title: APIN0114, APIN0115 802.11a/b/g/n
To: FCC 47 CFR Part 15.407 & IC RSS-210
Serial #: ARUB149-U4 Rev A
Issue Date: 5th August 2013
Page: 67 of 257

Test Freq.	5580 MHz	Engineer	SB
Variant	802.11a; 6 Mbs	Temp (°C)	24
Freq. Range	1000 MHz - 18000 MHz	Rel. Hum.(%)	30
Power Setting	17.5	Press. (mBars)	1010
Antenna	AP-ANT-1B	Duty Cycle (%)	100
Test Notes 1			
Test Notes 2			

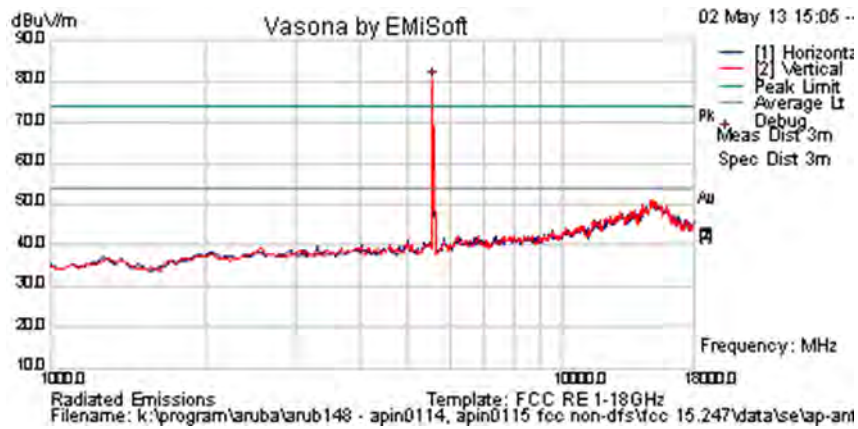

Formally measured emission peaks

Frequency MHz	Raw dBuV	Cable Loss	AF dB	Level dBuV/m	Measurement Type	Pol	Hgt cm	Azt Deg	Limit dBuV/m	Margin dB	Pass /Fail	Comments
5565.130	85.0	4.9	-9.7	80.3	Peak [Scan]	V	100	0				FUND
Legend: TX = Transmitter Emissions; DIG = Digital Emissions; FUND = Fundamental; WB = Wideband Emission NRB = Non-Restricted Band. Limit = 68.23 dBuV/m; RB = Restricted Band. Limits per 15.205												

This test report may be reproduced in full only. The document may only be updated by MiCOM Labs personnel. Any changes will be noted in the Document History section of the report.



Title: APIN0114, APIN0115 802.11a/b/g/n
To: FCC 47 CFR Part 15.407 & IC RSS-210
Serial #: ARUB149-U4 Rev A
Issue Date: 5th August 2013
Page: 68 of 257

Test Freq.	5700 MHz	Engineer	SB
Variant	802.11a; 6 Mbs	Temp (°C)	24
Freq. Range	1000 MHz - 18000 MHz	Rel. Hum.(%)	30
Power Setting	18.5	Press. (mBars)	1010
Antenna	AP-ANT-1B	Duty Cycle (%)	100
Test Notes 1			
Test Notes 2			

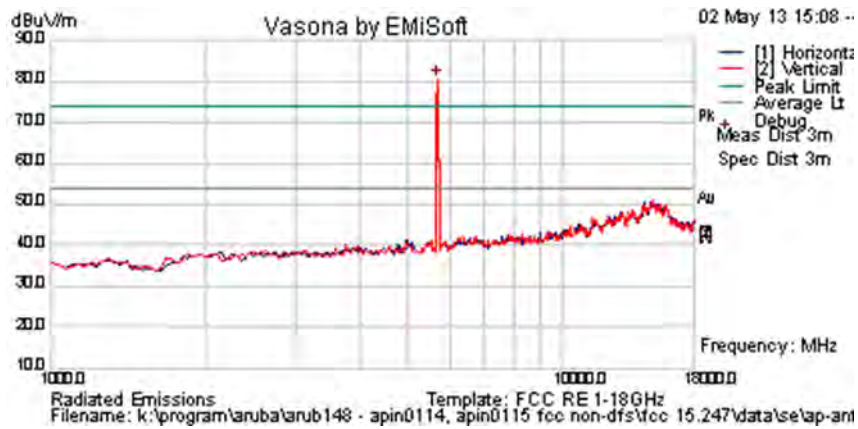

Formally measured emission peaks

Frequency MHz	Raw dBuV	Cable Loss	AF dB	Level dBuV/m	Measurement Type	Pol	Hgt cm	Azt Deg	Limit dBuV/m	Margin dB	Pass /Fail	Comments
5701.403	85.1	5.0	-9.6	80.5	Peak [Scan]	H	100	0				FUND
Legend: TX = Transmitter Emissions; DIG = Digital Emissions; FUND = Fundamental; WB = Wideband Emission NRB = Non-Restricted Band. Limit = 68.23 dBuV/m; RB = Restricted Band. Limits per 15.205												

This test report may be reproduced in full only. The document may only be updated by MiCOM Labs personnel. Any changes will be noted in the Document History section of the report.



Title: APIN0114, APIN0115 802.11a/b/g/n
To: FCC 47 CFR Part 15.407 & IC RSS-210
Serial #: ARUB149-U4 Rev A
Issue Date: 5th August 2013
Page: 69 of 257

6.1.2.3. ANT-13B – Spurious Emissions

Test Freq.	5260 MHz	Engineer	JMH
Variant	802.11a; 6 Mbs	Temp (°C)	29
Freq. Range	1000 MHz - 18000 MHz	Rel. Hum.(%)	32
Power Setting	15.0	Press. (mBars)	1002
Antenna	AP-ANT-13B	Duty Cycle (%)	100
Test Notes 1			
Test Notes 2			

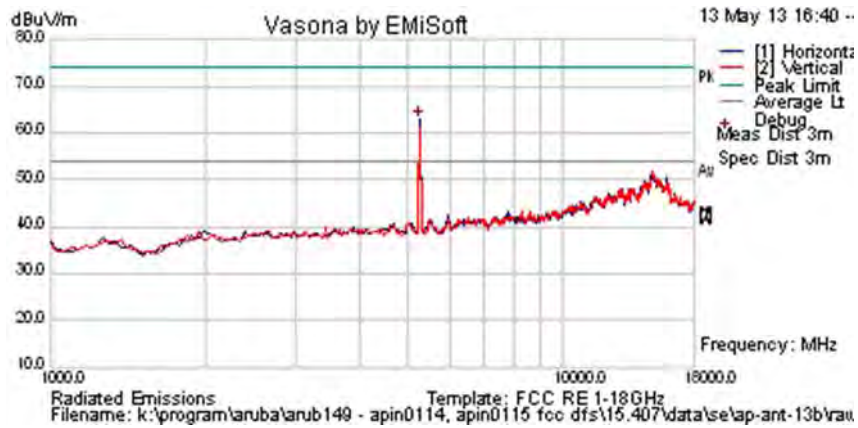

Formally measured emission peaks

Frequency MHz	Raw dBuV	Cable Loss	AF dB	Level dBuV/m	Measurement Type	PoI	Hgt cm	Azt Deg	Limit dBuV/m	Margin dB	Pass /Fail	Comments
5258.517	67.9	4.8	-9.7	63.0	Peak [Scan]	H						FUND
Legend: TX = Transmitter Emissions; DIG = Digital Emissions; FUND = Fundamental; WB = Wideband Emission NRB = Non-Restricted Band. Limit = 68.23 dBuV/m; RB = Restricted Band. Limits per 15.205												

This test report may be reproduced in full only. The document may only be updated by MiCOM Labs personnel. Any changes will be noted in the Document History section of the report.



Title: APIN0114, APIN0115 802.11a/b/g/n
To: FCC 47 CFR Part 15.407 & IC RSS-210
Serial #: ARUB149-U4 Rev A
Issue Date: 5th August 2013
Page: 70 of 257

Test Freq.	5300 MHz	Engineer	JMH
Variant	802.11a; 6 Mbs	Temp (°C)	29
Freq. Range	1000 MHz - 18000 MHz	Rel. Hum.(%)	32
Power Setting	15.0	Press. (mBars)	1002
Antenna	AP-ANT-13B	Duty Cycle (%)	100
Test Notes 1			
Test Notes 2			

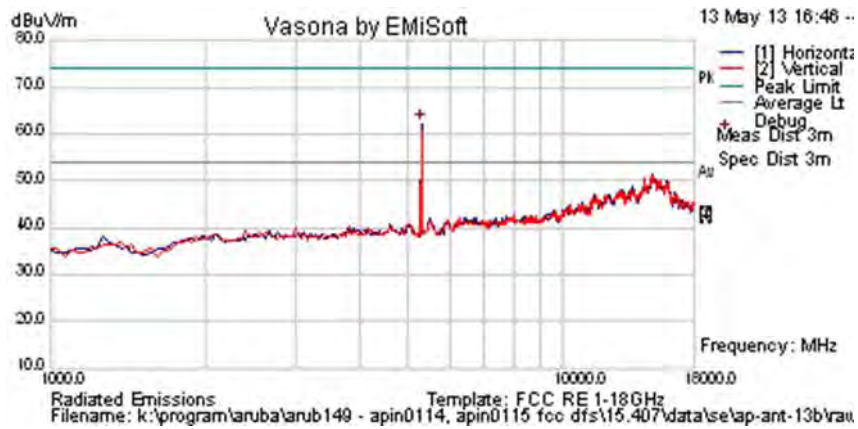

Formally measured emission peaks

Frequency MHz	Raw dBuV	Cable Loss	AF dB	Level dBuV/m	Measurement Type	Pol	Hgt cm	Azt Deg	Limit dBuV/m	Margin dB	Pass /Fail	Comments
5292.585	67.0	4.8	-9.6	62.2	Peak [Scan]	H						FUND
Legend: TX = Transmitter Emissions; DIG = Digital Emissions; FUND = Fundamental; WB = Wideband Emission NRB = Non-Restricted Band. Limit = 68.23 dBuV/m; RB = Restricted Band. Limits per 15.205												

This test report may be reproduced in full only. The document may only be updated by MiCOM Labs personnel. Any changes will be noted in the Document History section of the report.



Title: APIN0114, APIN0115 802.11a/b/g/n
To: FCC 47 CFR Part 15.407 & IC RSS-210
Serial #: ARUB149-U4 Rev A
Issue Date: 5th August 2013
Page: 71 of 257

Test Freq.	5320 MHz	Engineer	JMH
Variant	802.11a; 6 Mbs	Temp (°C)	29
Freq. Range	1000 MHz - 18000 MHz	Rel. Hum.(%)	32
Power Setting	15.0	Press. (mBars)	1002
Antenna	AP-ANT-13B	Duty Cycle (%)	100
Test Notes 1			
Test Notes 2			

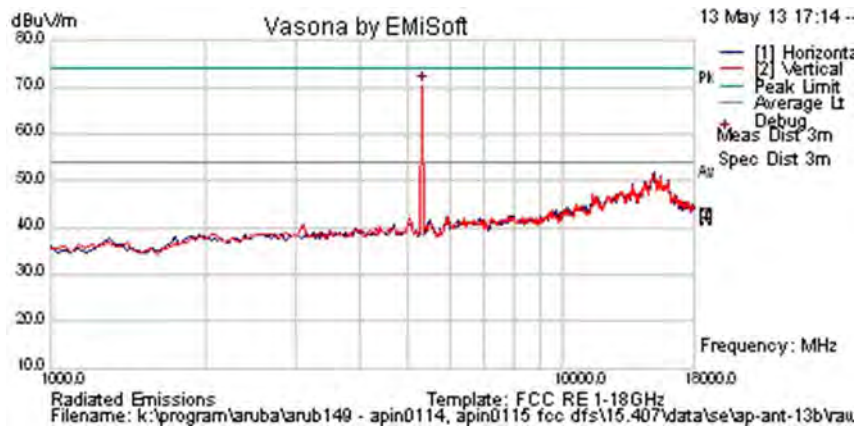

Formally measured emission peaks

Frequency MHz	Raw dBuV	Cable Loss	AF dB	Level dBuV/m	Measurement Type	Pol	Hgt cm	Azt Deg	Limit dBuV/m	Margin dB	Pass /Fail	Comments
5326.653	75.1	4.9	-9.5	70.4	Peak [Scan]	V						FUND
Legend: TX = Transmitter Emissions; DIG = Digital Emissions; FUND = Fundamental; WB = Wideband Emission NRB = Non-Restricted Band. Limit = 68.23 dBuV/m; RB = Restricted Band. Limits per 15.205												

This test report may be reproduced in full only. The document may only be updated by MiCOM Labs personnel. Any changes will be noted in the Document History section of the report.



Title: APIN0114, APIN0115 802.11a/b/g/n
To: FCC 47 CFR Part 15.407 & IC RSS-210
Serial #: ARUB149-U4 Rev A
Issue Date: 5th August 2013
Page: 72 of 257

Test Freq.	5500 MHz	Engineer	JMH
Variant	802.11a; 6 Mbs	Temp (°C)	29
Freq. Range	1000 MHz - 18000 MHz	Rel. Hum.(%)	32
Power Setting	17.0	Press. (mBars)	1002
Antenna	AP-ANT-13B	Duty Cycle (%)	100
Test Notes 1			
Test Notes 2			

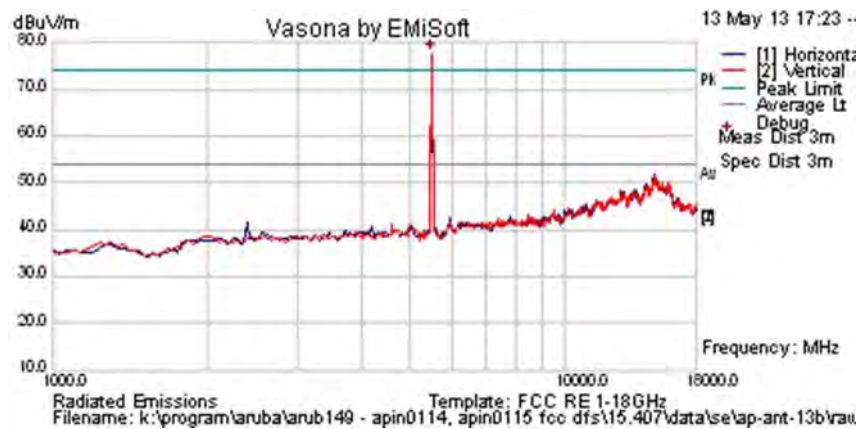

Formally measured emission peaks

Frequency MHz	Raw dBuV	Cable Loss	AF dB	Level dBuV/m	Measurement Type	Pol	Hgt cm	Azt Deg	Limit dBuV/m	Margin dB	Pass /Fail	Comments
5496.994	82.3	5.0	-9.6	77.7	Peak [Scan]	V						FUND
Legend: TX = Transmitter Emissions; DIG = Digital Emissions; FUND = Fundamental; WB = Wideband Emission NRB = Non-Restricted Band. Limit = 68.23 dBuV/m; RB = Restricted Band. Limits per 15.205												

This test report may be reproduced in full only. The document may only be updated by MiCOM Labs personnel. Any changes will be noted in the Document History section of the report.



Title: APIN0114, APIN0115 802.11a/b/g/n
To: FCC 47 CFR Part 15.407 & IC RSS-210
Serial #: ARUB149-U4 Rev A
Issue Date: 5th August 2013
Page: 73 of 257

Test Freq.	5580 MHz	Engineer	JMH
Variant	802.11a; 6 Mbs	Temp (°C)	29
Freq. Range	1000 MHz - 18000 MHz	Rel. Hum.(%)	32
Power Setting	17.5	Press. (mBars)	1002
Antenna	AP-ANT-13B	Duty Cycle (%)	100
Test Notes 1			
Test Notes 2			

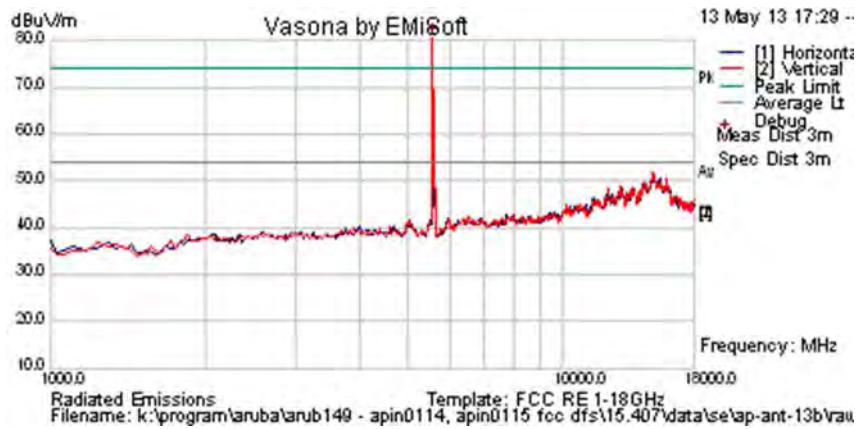

Formally measured emission peaks

Frequency MHz	Raw dBuV	Cable Loss	AF dB	Level dBuV/m	Measurement Type	Pol	Hgt cm	Azt Deg	Limit dBuV/m	Margin dB	Pass /Fail	Comments
5565.130	85.4	4.9	-9.7	80.7	Peak [Scan]	V						FUND
Legend: TX = Transmitter Emissions; DIG = Digital Emissions; FUND = Fundamental; WB = Wideband Emission NRB = Non-Restricted Band. Limit = 68.23 dBuV/m; RB = Restricted Band. Limits per 15.205												

This test report may be reproduced in full only. The document may only be updated by MiCOM Labs personnel. Any changes will be noted in the Document History section of the report.



Title: APIN0114, APIN0115 802.11a/b/g/n
To: FCC 47 CFR Part 15.407 & IC RSS-210
Serial #: ARUB149-U4 Rev A
Issue Date: 5th August 2013
Page: 74 of 257

Test Freq.	5700 MHz	Engineer	JMH
Variant	802.11a; 6 Mbs	Temp (°C)	29
Freq. Range	1000 MHz - 18000 MHz	Rel. Hum.(%)	32
Power Setting	18.5	Press. (mBars)	1002
Antenna	AP-ANT-13B	Duty Cycle (%)	100
Test Notes 1			
Test Notes 2			

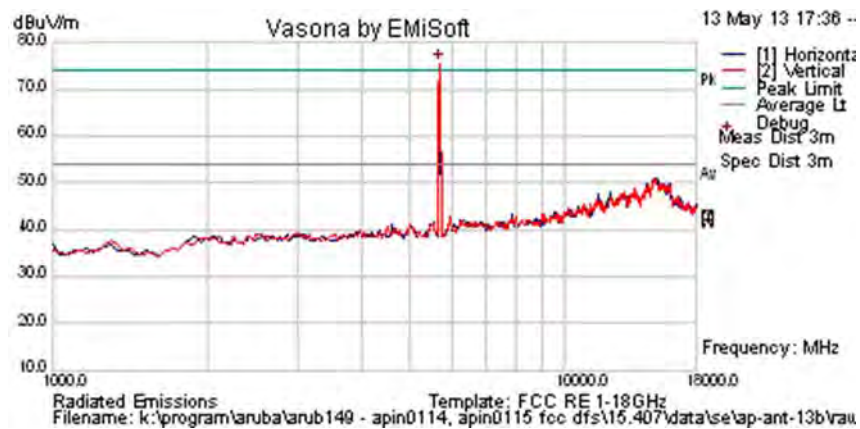

Formally measured emission peaks

Frequency MHz	Raw dBuV	Cable Loss	AF dB	Level dBuV/m	Measurement Type	Pol	Hgt cm	Azt Deg	Limit dBuV/m	Margin dB	Pass /Fail	Comments
5701.403	80.1	5.0	-9.6	75.5	Peak [Scan]	V						FUND
Legend: TX = Transmitter Emissions; DIG = Digital Emissions; FUND = Fundamental; WB = Wideband Emission NRB = Non-Restricted Band. Limit = 68.23 dBuV/m; RB = Restricted Band. Limits per 15.205												

This test report may be reproduced in full only. The document may only be updated by MiCOM Labs personnel. Any changes will be noted in the Document History section of the report.



6.1.2.4. ANT-16 – Spurious Emissions

Test Freq.	5260 MHz	Engineer	SB
Variant	802.11a; 6 Mbs	Temp (°C)	24
Freq. Range	1000 MHz - 18000 MHz	Rel. Hum.(%)	30
Power Setting	15.0	Press. (mBars)	1010
Antenna	AP-ANT-16	Duty Cycle (%)	100
Test Notes 1			
Test Notes 2			

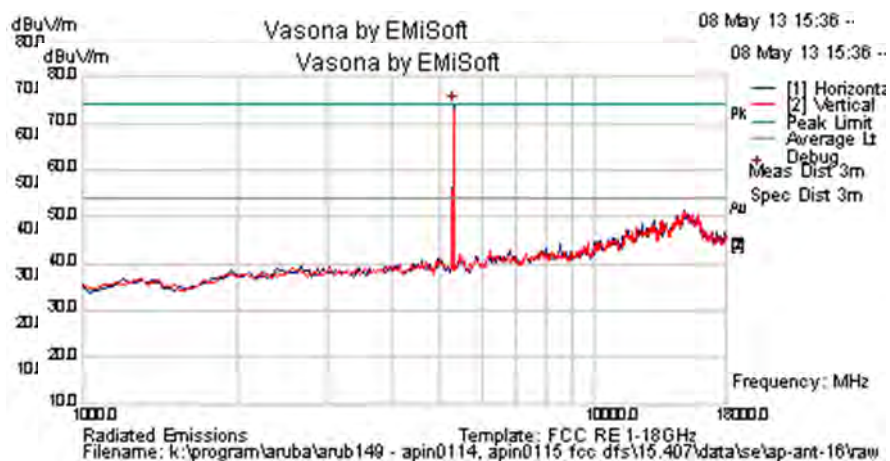

Formally measured emission peaks

Frequency MHz	Raw dBuV	Cable Loss	AF dB	Level dBuV/m	Measurement Type	Pol	Hgt cm	Azt Deg	Limit dBuV/m	Margin dB	Pass /Fail	Comments
5258.517	73.3	4.8	-9.7	68.3	Peak [Scan]	V	100	0				FUND
Legend: TX = Transmitter Emissions; DIG = Digital Emissions; FUND = Fundamental; WB = Wideband Emission NRB = Non-Restricted Band. Limit = 68.23 dBuV/m; RB = Restricted Band. Limits per 15.205												

This test report may be reproduced in full only. The document may only be updated by MiCOM Labs personnel. Any changes will be noted in the Document History section of the report.



Title: APIN0114, APIN0115 802.11a/b/g/n
To: FCC 47 CFR Part 15.407 & IC RSS-210
Serial #: ARUB149-U4 Rev A
Issue Date: 5th August 2013
Page: 76 of 257

Test Freq.	5300 MHz	Engineer	SB
Variant	802.11a; 6 Mbs	Temp (°C)	24
Freq. Range	1000 MHz - 18000 MHz	Rel. Hum.(%)	30
Power Setting	15.0	Press. (mBars)	1010
Antenna	AP-ANT-16	Duty Cycle (%)	100
Test Notes 1			
Test Notes 2			

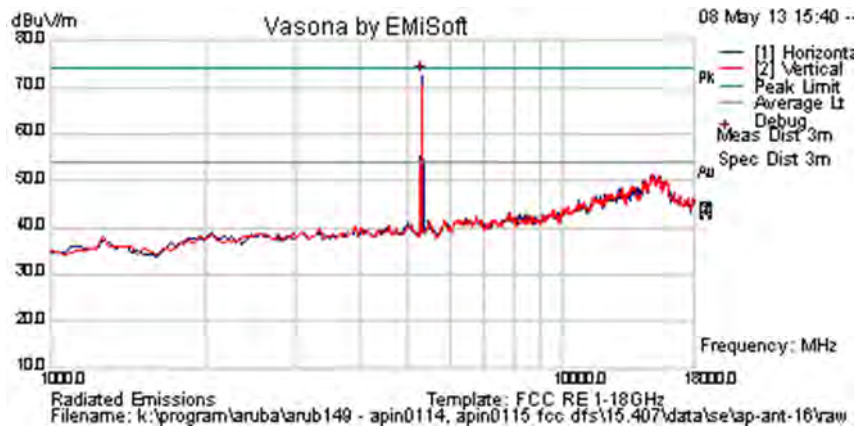

Formally measured emission peaks

Frequency MHz	Raw dBuV	Cable Loss	AF dB	Level dBuV/m	Measurement Type	Pol	Hgt cm	Azt Deg	Limit dBuV/m	Margin dB	Pass /Fail	Comments
5292.585	78.6	4.8	-9.6	73.8	Peak [Scan]	H	100	0				FUND
Legend: TX = Transmitter Emissions; DIG = Digital Emissions; FUND = Fundamental; WB = Wideband Emission NRB = Non-Restricted Band. Limit = 68.23 dBuV/m; RB = Restricted Band. Limits per 15.205												

This test report may be reproduced in full only. The document may only be updated by MiCOM Labs personnel. Any changes will be noted in the Document History section of the report.



Title: APIN0114, APIN0115 802.11a/b/g/n
To: FCC 47 CFR Part 15.407 & IC RSS-210
Serial #: ARUB149-U4 Rev A
Issue Date: 5th August 2013
Page: 77 of 257

Test Freq.	5320 MHz	Engineer	SB
Variant	802.11a; 6 Mbs	Temp (°C)	24
Freq. Range	1000 MHz - 18000 MHz	Rel. Hum.(%)	30
Power Setting	15.0	Press. (mBars)	1010
Antenna	AP-ANT-16	Duty Cycle (%)	100
Test Notes 1			
Test Notes 2			

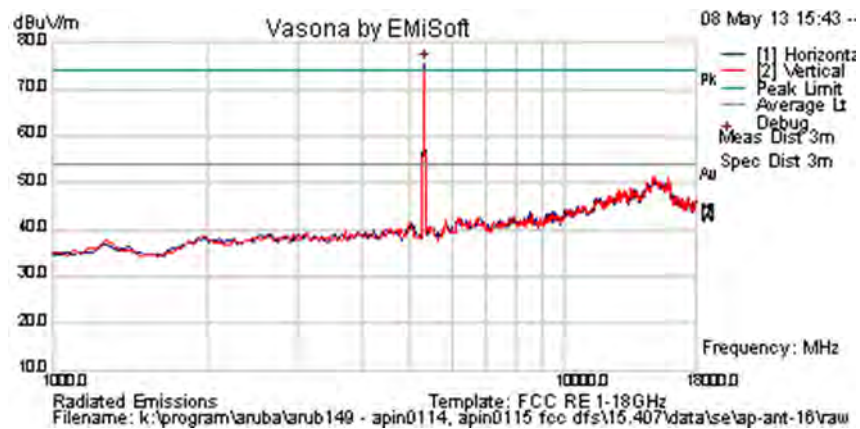

Formally measured emission peaks

Frequency MHz	Raw dBuV	Cable Loss	AF dB	Level dBuV/m	Measurement Type	Pol	Hgt cm	Azt Deg	Limit dBuV/m	Margin dB	Pass /Fail	Comments
5326.653	80.1	4.9	-9.5	75.5	Peak [Scan]	H	100	0				FUND
Legend: TX = Transmitter Emissions; DIG = Digital Emissions; FUND = Fundamental; WB = Wideband Emission NRB = Non-Restricted Band. Limit = 68.23 dBuV/m; RB = Restricted Band. Limits per 15.205												

This test report may be reproduced in full only. The document may only be updated by MiCOM Labs personnel. Any changes will be noted in the Document History section of the report.



Title: APIN0114, APIN0115 802.11a/b/g/n
To: FCC 47 CFR Part 15.407 & IC RSS-210
Serial #: ARUB149-U4 Rev A
Issue Date: 5th August 2013
Page: 78 of 257

Test Freq.	5500 MHz	Engineer	SB
Variant	802.11a; 6 Mbs	Temp (°C)	24
Freq. Range	1000 MHz - 18000 MHz	Rel. Hum.(%)	30
Power Setting	17.0	Press. (mBars)	1010
Antenna	AP-ANT-16	Duty Cycle (%)	100
Test Notes 1			
Test Notes 2			

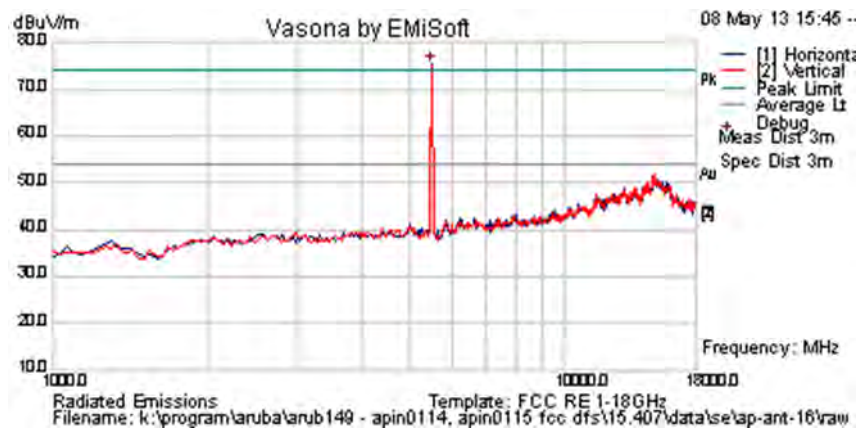

Formally measured emission peaks

Frequency MHz	Raw dBuV	Cable Loss	AF dB	Level dBuV/m	Measurement Type	Pol	Hgt cm	Azt Deg	Limit dBuV/m	Margin dB	Pass /Fail	Comments
5496.994	79.9	5.0	-9.6	75.3	Peak [Scan]	H	100	0				FUND
Legend: TX = Transmitter Emissions; DIG = Digital Emissions; FUND = Fundamental; WB = Wideband Emission NRB = Non-Restricted Band. Limit = 68.23 dBuV/m; RB = Restricted Band. Limits per 15.205												

This test report may be reproduced in full only. The document may only be updated by MiCOM Labs personnel. Any changes will be noted in the Document History section of the report.



Title: APIN0114, APIN0115 802.11a/b/g/n
To: FCC 47 CFR Part 15.407 & IC RSS-210
Serial #: ARUB149-U4 Rev A
Issue Date: 5th August 2013
Page: 79 of 257

Test Freq.	5580 MHz	Engineer	SB
Variant	802.11a; 6 Mbs	Temp (°C)	24
Freq. Range	1000 MHz - 18000 MHz	Rel. Hum.(%)	30
Power Setting	17.5	Press. (mBars)	1010
Antenna	AP-ANT-16	Duty Cycle (%)	100
Test Notes 1			
Test Notes 2			

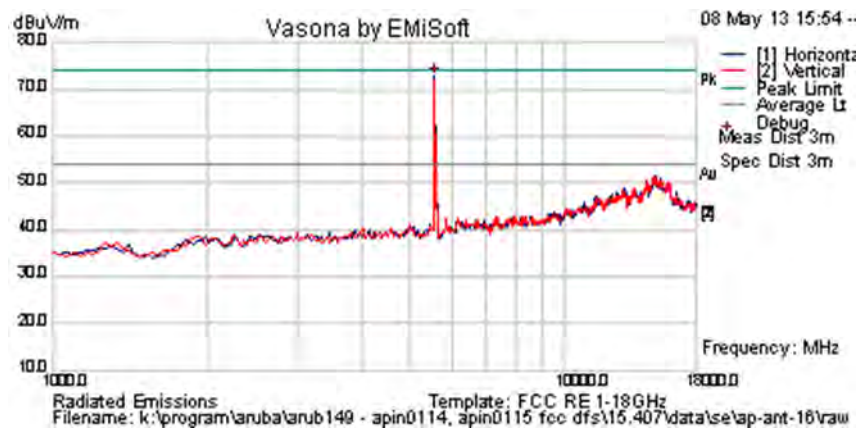

Formally measured emission peaks

Frequency MHz	Raw dBuV	Cable Loss	AF dB	Level dBuV/m	Measurement Type	Pol	Hgt cm	Azt Deg	Limit dBuV/m	Margin dB	Pass /Fail	Comments
5565.130	77.5	4.9	-9.7	72.7	Peak [Scan]	H	100	0				FUND
Legend: TX = Transmitter Emissions; DIG = Digital Emissions; FUND = Fundamental; WB = Wideband Emission NRB = Non-Restricted Band. Limit = 68.23 dBuV/m; RB = Restricted Band. Limits per 15.205												

This test report may be reproduced in full only. The document may only be updated by MiCOM Labs personnel. Any changes will be noted in the Document History section of the report.



Title: APIN0114, APIN0115 802.11a/b/g/n
To: FCC 47 CFR Part 15.407 & IC RSS-210
Serial #: ARUB149-U4 Rev A
Issue Date: 5th August 2013
Page: 80 of 257

Test Freq.	5700 MHz	Engineer	SB
Variant	802.11a; 6 Mbs	Temp (°C)	24
Freq. Range	1000 MHz - 18000 MHz	Rel. Hum.(%)	30
Power Setting	18.5	Press. (mBars)	1010
Antenna	AP-ANT-16	Duty Cycle (%)	100
Test Notes 1			
Test Notes 2			

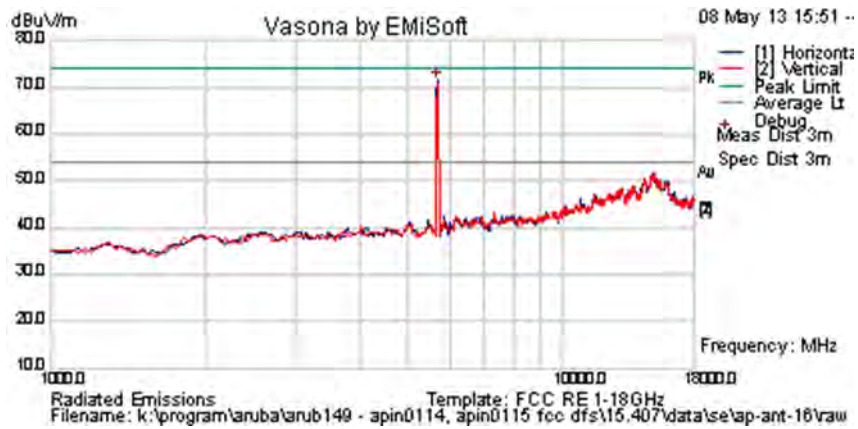

Formally measured emission peaks

Frequency MHz	Raw dBuV	Cable Loss	AF dB	Level dBuV/m	Measurement Type	Pol	Hgt cm	Azt Deg	Limit dBuV/m	Margin dB	Pass /Fail	Comments
5701.403	76.0	5.0	-9.6	71.4	Peak [Scan]	H	100	0				FUND
Legend: TX = Transmitter Emissions; DIG = Digital Emissions; FUND = Fundamental; WB = Wideband Emission NRB = Non-Restricted Band. Limit = 68.23 dBuV/m; RB = Restricted Band. Limits per 15.205												

This test report may be reproduced in full only. The document may only be updated by MiCOM Labs personnel. Any changes will be noted in the Document History section of the report.



Title: APIN0114, APIN0115 802.11a/b/g/n
To: FCC 47 CFR Part 15.407 & IC RSS-210
Serial #: ARUB149-U4 Rev A
Issue Date: 5th August 2013
Page: 81 of 257

6.1.2.5. ANT-18 – Spurious Emissions

Test Freq.	5260 MHz	Engineer	SB
Variant	802.11a; 6 Mbs	Temp (°C)	24
Freq. Range	1000 MHz - 18000 MHz	Rel. Hum.(%)	30
Power Setting	15.0	Press. (mBars)	1010
Antenna	AP-ANT-19	Duty Cycle (%)	100
Test Notes 1			
Test Notes 2			

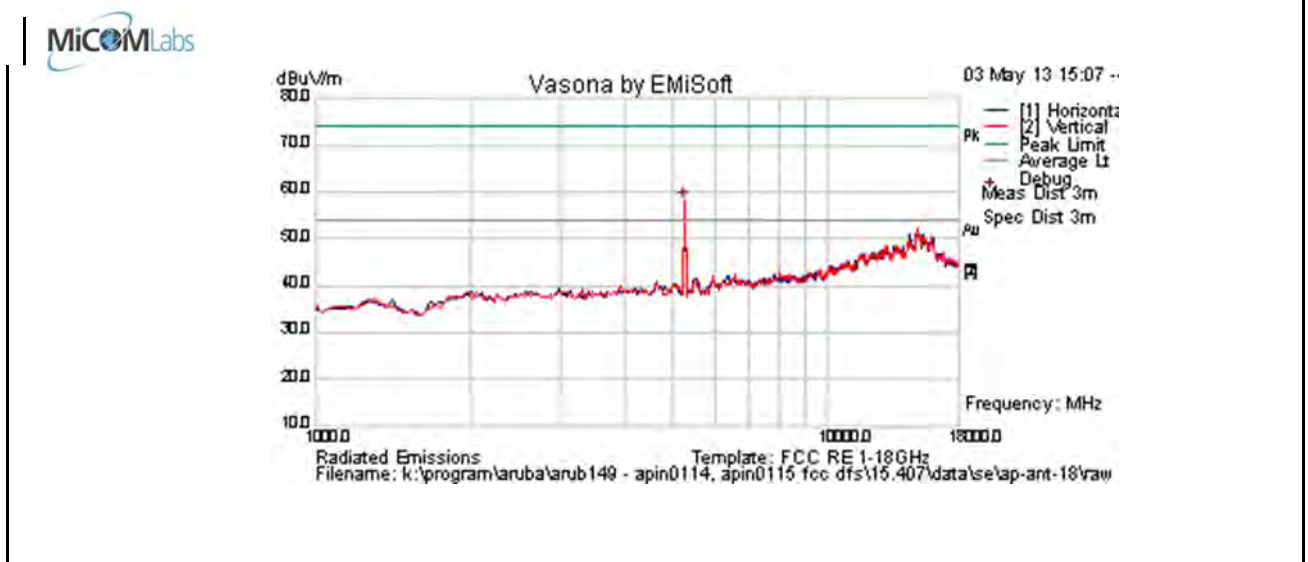

Formally measured emission peaks

Frequency MHz	Raw dBuV	Cable Loss	AF dB	Level dBuV/m	Measurement Type	PoI	Hgt cm	Azt Deg	Limit dBuV/m	Margin dB	Pass /Fail	Comments
5258.517	63.1	4.8	-9.7	58.2	Peak [Scan]	V	150	0				FUND
Legend: TX = Transmitter Emissions; DIG = Digital Emissions; FUND = Fundamental; WB = Wideband Emission NRB = Non-Restricted Band. Limit = 68.23 dBuV/m; RB = Restricted Band. Limits per 15.205												

This test report may be reproduced in full only. The document may only be updated by MiCOM Labs personnel. Any changes will be noted in the Document History section of the report.



Title: APIN0114, APIN0115 802.11a/b/g/n
To: FCC 47 CFR Part 15.407 & IC RSS-210
Serial #: ARUB149-U4 Rev A
Issue Date: 5th August 2013
Page: 82 of 257

Test Freq.	5300 MHz	Engineer	SB
Variant	802.11a; 6 Mbs	Temp (°C)	24
Freq. Range	1000 MHz - 18000 MHz	Rel. Hum.(%)	30
Power Setting	15.0	Press. (mBars)	1010
Antenna	AP-ANT-19	Duty Cycle (%)	100
Test Notes 1			
Test Notes 2			

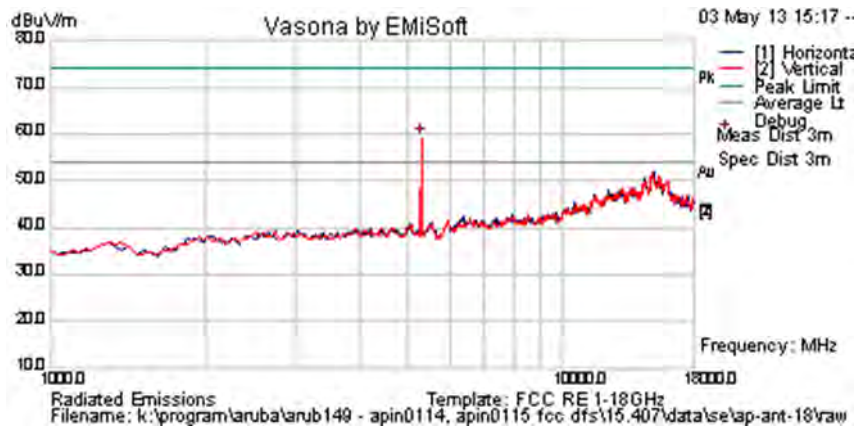

Formally measured emission peaks

Frequency MHz	Raw dBuV	Cable Loss	AF dB	Level dBuV/m	Measurement Type	Pol	Hgt cm	Azt Deg	Limit dBuV/m	Margin dB	Pass /Fail	Comments
5292.585	64.0	4.8	-9.6	59.2	Peak [Scan]	V	150	0				FUND
Legend: TX = Transmitter Emissions; DIG = Digital Emissions; FUND = Fundamental; WB = Wideband Emission NRB = Non-Restricted Band. Limit = 68.23 dBuV/m; RB = Restricted Band. Limits per 15.205												

This test report may be reproduced in full only. The document may only be updated by MiCOM Labs personnel. Any changes will be noted in the Document History section of the report.



Title: APIN0114, APIN0115 802.11a/b/g/n
To: FCC 47 CFR Part 15.407 & IC RSS-210
Serial #: ARUB149-U4 Rev A
Issue Date: 5th August 2013
Page: 83 of 257

Test Freq.	5320 MHz	Engineer	SB
Variant	802.11a; 6 Mbs	Temp (°C)	24
Freq. Range	1000 MHz - 18000 MHz	Rel. Hum.(%)	30
Power Setting	15.0	Press. (mBars)	1010
Antenna	AP-ANT-19	Duty Cycle (%)	100
Test Notes 1			
Test Notes 2			

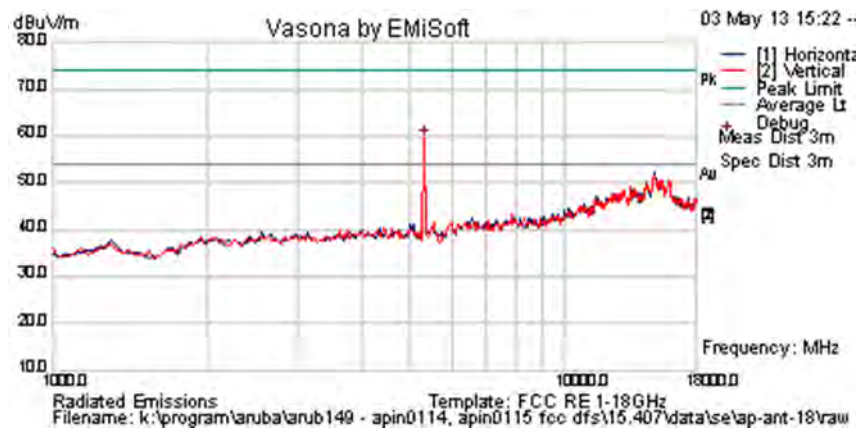

Formally measured emission peaks

Frequency MHz	Raw dBuV	Cable Loss	AF dB	Level dBuV/m	Measurement Type	Pol	Hgt cm	Azt Deg	Limit dBuV/m	Margin dB	Pass /Fail	Comments
5326.653	64.2	4.9	-9.5	59.5	Peak [Scan]	V	150	0				FUND
Legend: TX = Transmitter Emissions; DIG = Digital Emissions; FUND = Fundamental; WB = Wideband Emission NRB = Non-Restricted Band. Limit = 68.23 dBuV/m; RB = Restricted Band. Limits per 15.205												

This test report may be reproduced in full only. The document may only be updated by MiCOM Labs personnel. Any changes will be noted in the Document History section of the report.



Title: APIN0114, APIN0115 802.11a/b/g/n
To: FCC 47 CFR Part 15.407 & IC RSS-210
Serial #: ARUB149-U4 Rev A
Issue Date: 5th August 2013
Page: 84 of 257

Test Freq.	5500 MHz	Engineer	SB
Variant	802.11a; 6 Mbs	Temp (°C)	24
Freq. Range	1000 MHz - 18000 MHz	Rel. Hum.(%)	30
Power Setting	17.0	Press. (mBars)	1010
Antenna	AP-ANT-19	Duty Cycle (%)	100
Test Notes 1			
Test Notes 2			

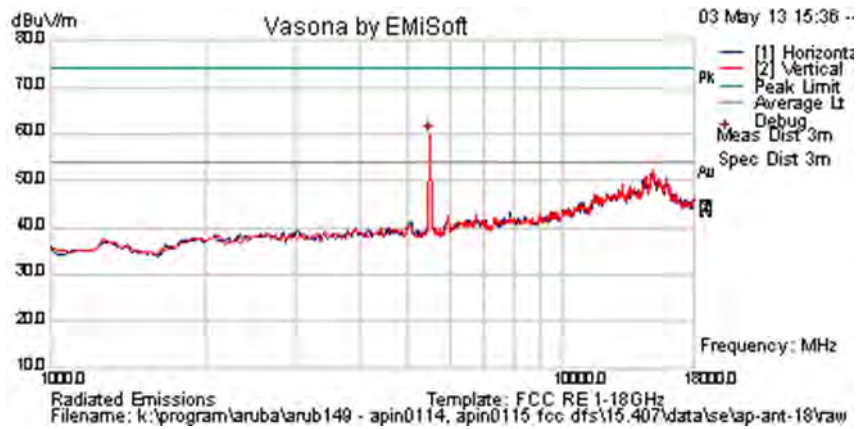

Formally measured emission peaks

Frequency MHz	Raw dBuV	Cable Loss	AF dB	Level dBuV/m	Measurement Type	Pol	Hgt cm	Azt Deg	Limit dBuV/m	Margin dB	Pass /Fail	Comments
5496.994	64.5	5.0	-9.6	59.9	Peak [Scan]	V	100	0				FUND
Legend: TX = Transmitter Emissions; DIG = Digital Emissions; FUND = Fundamental; WB = Wideband Emission NRB = Non-Restricted Band. Limit = 68.23 dBuV/m; RB = Restricted Band. Limits per 15.205												

This test report may be reproduced in full only. The document may only be updated by MiCOM Labs personnel. Any changes will be noted in the Document History section of the report.



Title: APIN0114, APIN0115 802.11a/b/g/n
To: FCC 47 CFR Part 15.407 & IC RSS-210
Serial #: ARUB149-U4 Rev A
Issue Date: 5th August 2013
Page: 85 of 257

Test Freq.	5580 MHz	Engineer	SB
Variant	802.11a; 6 Mbs	Temp (°C)	24
Freq. Range	1000 MHz - 18000 MHz	Rel. Hum.(%)	30
Power Setting	17.5	Press. (mBars)	1010
Antenna	AP-ANT-19	Duty Cycle (%)	100
Test Notes 1			
Test Notes 2			

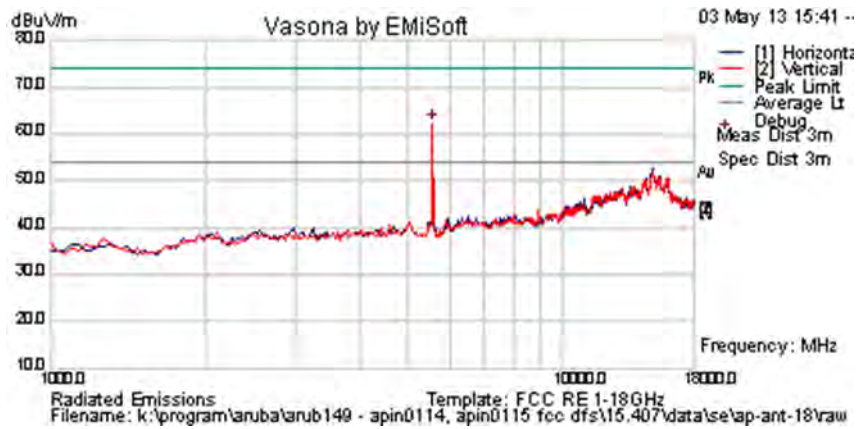

Formally measured emission peaks

Frequency MHz	Raw dBuV	Cable Loss	AF dB	Level dBuV/m	Measurement Type	Pol	Hgt cm	Azt Deg	Limit dBuV/m	Margin dB	Pass /Fail	Comments
5565.130	67.0	4.9	-9.7	62.3	Peak [Scan]	V	150	0				FUND
Legend: TX = Transmitter Emissions; DIG = Digital Emissions; FUND = Fundamental; WB = Wideband Emission NRB = Non-Restricted Band. Limit = 68.23 dBuV/m; RB = Restricted Band. Limits per 15.205												

This test report may be reproduced in full only. The document may only be updated by MiCOM Labs personnel. Any changes will be noted in the Document History section of the report.



Title: APIN0114, APIN0115 802.11a/b/g/n
To: FCC 47 CFR Part 15.407 & IC RSS-210
Serial #: ARUB149-U4 Rev A
Issue Date: 5th August 2013
Page: 86 of 257

Test Freq.	5700 MHz	Engineer	SB
Variant	802.11a; 6 Mbs	Temp (°C)	24
Freq. Range	1000 MHz - 18000 MHz	Rel. Hum.(%)	30
Power Setting	18.5	Press. (mBars)	1010
Antenna	AP-ANT-19	Duty Cycle (%)	100
Test Notes 1			
Test Notes 2			

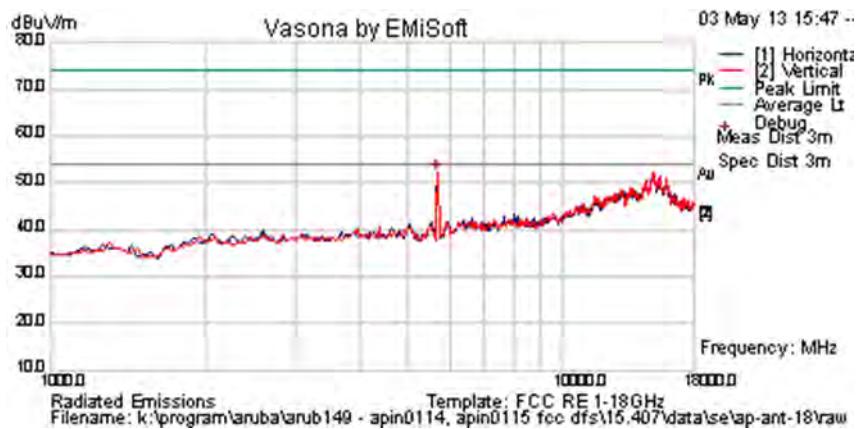

Formally measured emission peaks

Frequency MHz	Raw dBuV	Cable Loss	AF dB	Level dBuV/m	Measurement Type	Pol	Hgt cm	Azt Deg	Limit dBuV/m	Margin dB	Pass /Fail	Comments
5701.403	56.8	5.0	-9.6	52.2	Peak [Scan]	V	100	0				FUND
Legend: TX = Transmitter Emissions; DIG = Digital Emissions; FUND = Fundamental; WB = Wideband Emission NRB = Non-Restricted Band. Limit = 68.23 dBuV/m; RB = Restricted Band. Limits per 15.205												

This test report may be reproduced in full only. The document may only be updated by MiCOM Labs personnel. Any changes will be noted in the Document History section of the report.



Title: APIN0114, APIN0115 802.11a/b/g/n
To: FCC 47 CFR Part 15.407 & IC RSS-210
Serial #: ARUB149-U4 Rev A
Issue Date: 5th August 2013
Page: 87 of 257

6.1.2.6. ANT-19 – Spurious Emissions

Test Freq.	5260 MHz	Engineer	SB
Variant	802.11a; 6 Mbs	Temp (°C)	24
Freq. Range	1000 MHz - 18000 MHz	Rel. Hum.(%)	30
Power Setting	15.0	Press. (mBars)	1010
Antenna	AP-ANT-19	Duty Cycle (%)	100
Test Notes 1			
Test Notes 2			

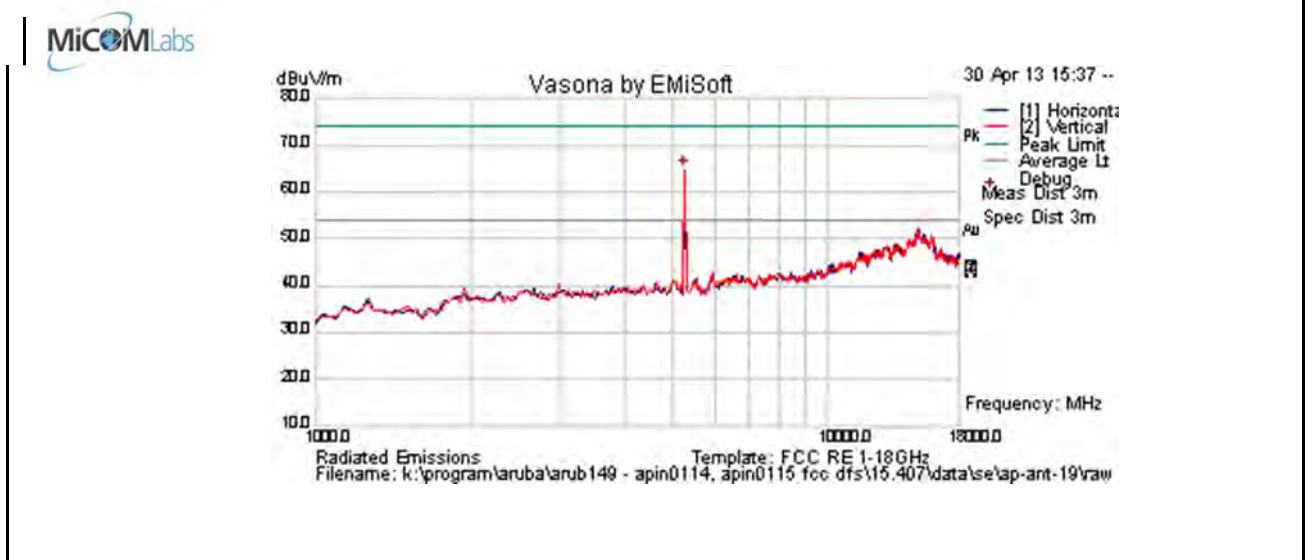

Formally measured emission peaks

Frequency MHz	Raw dBuV	Cable Loss	AF dB	Level dBuV/m	Measurement Type	PoI	Hgt cm	Azt Deg	Limit dBuV/m	Margin dB	Pass /Fail	Comments
5258.517	69.8	4.8	-9.7	64.9	Peak [Scan]	V	100	0				FUND
Legend: TX = Transmitter Emissions; DIG = Digital Emissions; FUND = Fundamental; WB = Wideband Emission NRB = Non-Restricted Band. Limit = 68.23 dBuV/m; RB = Restricted Band. Limits per 15.205												

This test report may be reproduced in full only. The document may only be updated by MiCOM Labs personnel. Any changes will be noted in the Document History section of the report.



Title: APIN0114, APIN0115 802.11a/b/g/n
To: FCC 47 CFR Part 15.407 & IC RSS-210
Serial #: ARUB149-U4 Rev A
Issue Date: 5th August 2013
Page: 88 of 257

Test Freq.	5300 MHz	Engineer	SB
Variant	802.11a; 6 Mbs	Temp (°C)	24
Freq. Range	1000 MHz - 18000 MHz	Rel. Hum.(%)	30
Power Setting	15.0	Press. (mBars)	1010
Antenna	AP-ANT-19	Duty Cycle (%)	100
Test Notes 1			
Test Notes 2			

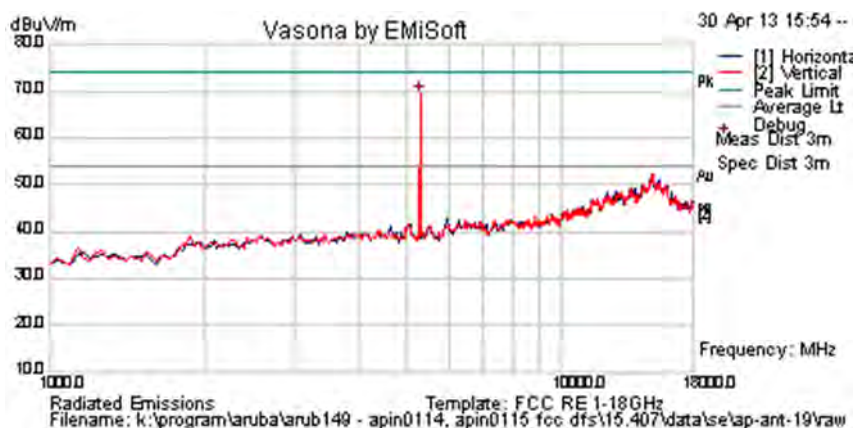

Formally measured emission peaks

Frequency MHz	Raw dBuV	Cable Loss	AF dB	Level dBuV/m	Measurement Type	Pol	Hgt cm	Azt Deg	Limit dBuV/m	Margin dB	Pass /Fail	Comments
5292.585	74.0	4.8	-9.6	69.2	Peak [Scan]	V	100	0				FUND
Legend: TX = Transmitter Emissions; DIG = Digital Emissions; FUND = Fundamental; WB = Wideband Emission NRB = Non-Restricted Band. Limit = 68.23 dBuV/m; RB = Restricted Band. Limits per 15.205												

This test report may be reproduced in full only. The document may only be updated by MiCOM Labs personnel. Any changes will be noted in the Document History section of the report.



Title: APIN0114, APIN0115 802.11a/b/g/n
To: FCC 47 CFR Part 15.407 & IC RSS-210
Serial #: ARUB149-U4 Rev A
Issue Date: 5th August 2013
Page: 89 of 257

Test Freq.	5320 MHz	Engineer	SB
Variant	802.11a; 6 Mbs	Temp (°C)	24
Freq. Range	1000 MHz - 18000 MHz	Rel. Hum.(%)	30
Power Setting	15.0	Press. (mBars)	1010
Antenna	AP-ANT-19	Duty Cycle (%)	100
Test Notes 1			
Test Notes 2			

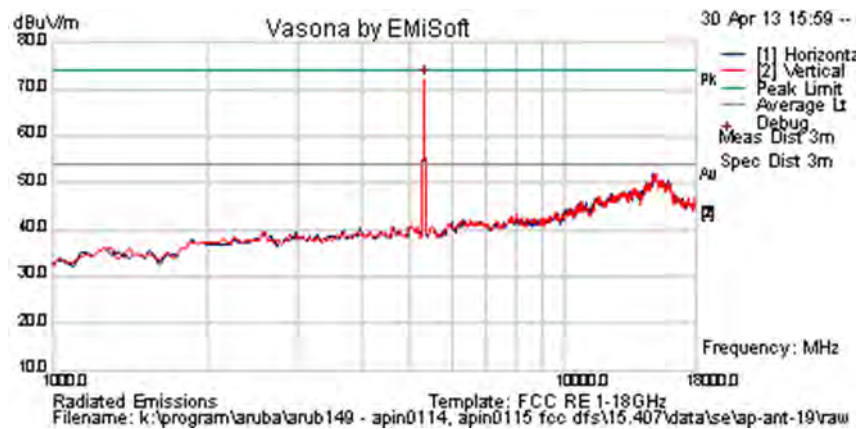

Formally measured emission peaks

Frequency MHz	Raw dBuV	Cable Loss	AF dB	Level dBuV/m	Measurement Type	Pol	Hgt cm	Azt Deg	Limit dBuV/m	Margin dB	Pass /Fail	Comments
5326.653	76.7	4.9	-9.5	72.1	Peak [Scan]	V	100	0				FUND
Legend: TX = Transmitter Emissions; DIG = Digital Emissions; FUND = Fundamental; WB = Wideband Emission NRB = Non-Restricted Band. Limit = 68.23 dBuV/m; RB = Restricted Band. Limits per 15.205												

This test report may be reproduced in full only. The document may only be updated by MiCOM Labs personnel. Any changes will be noted in the Document History section of the report.



Title: APIN0114, APIN0115 802.11a/b/g/n
To: FCC 47 CFR Part 15.407 & IC RSS-210
Serial #: ARUB149-U4 Rev A
Issue Date: 5th August 2013
Page: 90 of 257

Test Freq.	5500 MHz	Engineer	SB
Variant	802.11a; 6 Mbs	Temp (°C)	24
Freq. Range	1000 MHz - 18000 MHz	Rel. Hum.(%)	30
Power Setting	17.0	Press. (mBars)	1010
Antenna	AP-ANT-19	Duty Cycle (%)	100
Test Notes 1			
Test Notes 2			

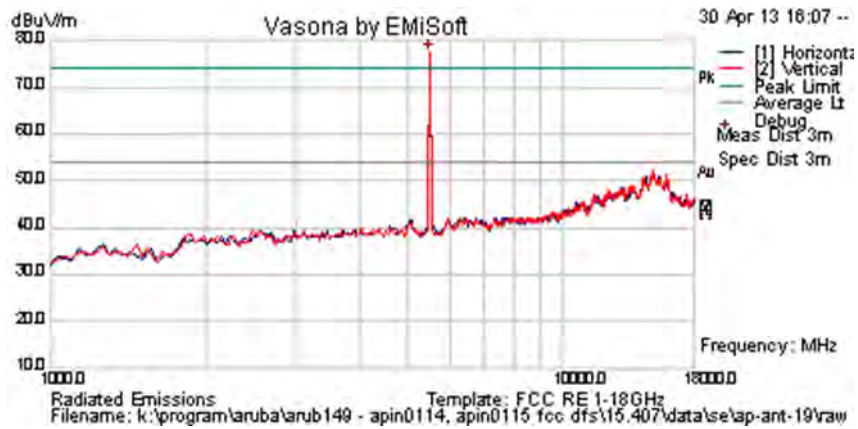

Formally measured emission peaks

Frequency MHz	Raw dBuV	Cable Loss	AF dB	Level dBuV/m	Measurement Type	Pol	Hgt cm	Azt Deg	Limit dBuV/m	Margin dB	Pass /Fail	Comments
5496.994	82.2	5.0	-9.6	77.6	Peak [Scan]	V	100	0				FUND
Legend: TX = Transmitter Emissions; DIG = Digital Emissions; FUND = Fundamental; WB = Wideband Emission NRB = Non-Restricted Band. Limit = 68.23 dBuV/m; RB = Restricted Band. Limits per 15.205												

This test report may be reproduced in full only. The document may only be updated by MiCOM Labs personnel. Any changes will be noted in the Document History section of the report.



Title: APIN0114, APIN0115 802.11a/b/g/n
To: FCC 47 CFR Part 15.407 & IC RSS-210
Serial #: ARUB149-U4 Rev A
Issue Date: 5th August 2013
Page: 91 of 257

Test Freq.	5580 MHz	Engineer	SB
Variant	802.11a; 6 Mbs	Temp (°C)	24
Freq. Range	1000 MHz - 18000 MHz	Rel. Hum.(%)	30
Power Setting	17.5	Press. (mBars)	1010
Antenna	AP-ANT-19	Duty Cycle (%)	100
Test Notes 1			
Test Notes 2			

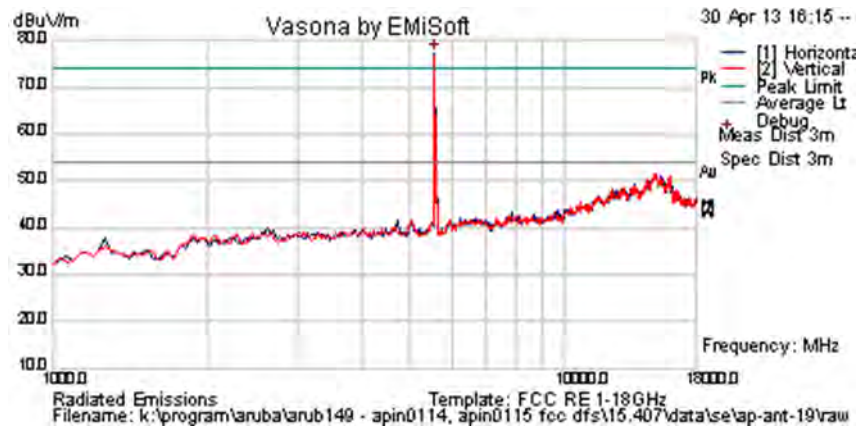

Formally measured emission peaks

Frequency MHz	Raw dBuV	Cable Loss	AF dB	Level dBuV/m	Measurement Type	Pol	Hgt cm	Azt Deg	Limit dBuV/m	Margin dB	Pass /Fail	Comments
5565.130	82.0	4.9	-9.7	77.3	Peak [Scan]	H	150	0				FUND
Legend: TX = Transmitter Emissions; DIG = Digital Emissions; FUND = Fundamental; WB = Wideband Emission NRB = Non-Restricted Band. Limit = 68.23 dBuV/m; RB = Restricted Band. Limits per 15.205												

This test report may be reproduced in full only. The document may only be updated by MiCOM Labs personnel. Any changes will be noted in the Document History section of the report.



Title: APIN0114, APIN0115 802.11a/b/g/n
To: FCC 47 CFR Part 15.407 & IC RSS-210
Serial #: ARUB149-U4 Rev A
Issue Date: 5th August 2013
Page: 92 of 257

Test Freq.	5700 MHz	Engineer	SB
Variant	802.11a; 6 Mbs	Temp (°C)	24
Freq. Range	1000 MHz - 18000 MHz	Rel. Hum.(%)	30
Power Setting	18.5	Press. (mBars)	1010
Antenna	AP-ANT-19	Duty Cycle (%)	100
Test Notes 1			
Test Notes 2			

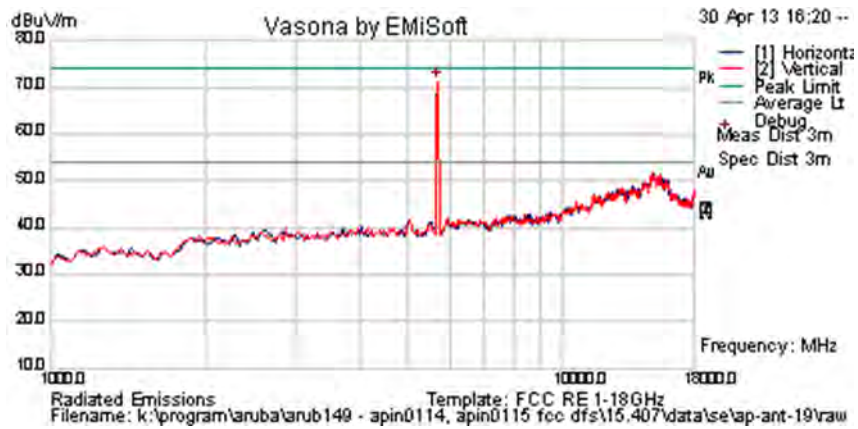

Formally measured emission peaks

Frequency MHz	Raw dBuV	Cable Loss	AF dB	Level dBuV/m	Measurement Type	Pol	Hgt cm	Azt Deg	Limit dBuV/m	Margin dB	Pass /Fail	Comments
5701.403	75.9	5.0	-9.6	71.3	Peak [Scan]	H	100	0				FUND
Legend: TX = Transmitter Emissions; DIG = Digital Emissions; FUND = Fundamental; WB = Wideband Emission NRB = Non-Restricted Band. Limit = 68.23 dBuV/m; RB = Restricted Band. Limits per 15.205												

This test report may be reproduced in full only. The document may only be updated by MiCOM Labs personnel. Any changes will be noted in the Document History section of the report.



6.1.2.7. Radiated Band-Edge - Integral Antenna

Peak Limit 74.0 dB μ V, Peak Limit 54.0 dB μ V

Operational Mode	5350 MHz		Power Setting
	dB μ V		
	Peak	Average	
a	69.44	48.73	15.0
n HT-20	72.16	50.97	15.0
n HT-40	73.13	52.16	15.5

Operational Mode	5460 MHz		
	Peak	Average	Power Setting
a	63.41	46.0	17.0
n HT-20	62.0	45.60	17.5
n HT-40	66.58	47.67	17.5

This test report may be reproduced in full only. The document may only be updated by MiCOM Labs personnel. Any changes will be noted in the Document History section of the report.



6.1.2.8. ANT1B - Radiated Band-Edge

Peak Limit 74.0 dBμV, Peak Limit 54.0 dBμV

5350 MHz			
Operational Mode	dBμV		Power Setting
	Peak	Average	
a	71.31	49.61	15.0
n HT-20	61.27	4.99	14.0
n HT-40	72.86	48.96	14.5

5460 MHz			
Operational Mode	Peak	Average	Power Setting
a	64.82	48.29	17.0
n HT-20	62.26	49.38	17.5
n HT-40	73.59	52.75	17.5



6.1.2.9. ANT13B - Radiated Band-Edge

Peak Limit 74.0 dBμV, Peak Limit 54.0 dBμV

5350 MHz			
Operational Mode	dBμV		Power Setting
	Peak	Average	
a	67.02	46.01	17.5
n HT-20	70.06	47.42	17.5
n HT-40	70.94	48.86	16.0

5460 MHz			
Operational Mode	Peak	Average	Power Setting
a	57.14	42.13	17.0
n HT-20	60.24	41.92	17.5
n HT-40	63.48	43.68	17.5

This test report may be reproduced in full only. The document may only be updated by MiCOM Labs personnel. Any changes will be noted in the Document History section of the report.



6.1.2.10.ANT16 - Radiated Band-Edge

Peak Limit 74.0 dB μ V, Peak Limit 54.0 dB μ V

5350 MHz			
Operational Mode	dB μ V		Power Setting
	Peak	Average	
a	56.26	37.82	15.0
n HT-20	56.83	37.49	15.0
n HT-40	64.74	42.42	16.0

5460 MHz			
Operational Mode	Peak	Average	Power Setting
a	50.66	38.20	17.0
n HT-20	56.55	37.88	17.5
n HT-40	64.57	42.79	18.5

This test report may be reproduced in full only. The document may only be updated by MiCOM Labs personnel. Any changes will be noted in the Document History section of the report.



6.1.2.11.ANT18 - Radiated Band-Edge

Peak Limit 74.0 dB μ V, Peak Limit 54.0 dB μ V

5350 MHz			
Operational Mode	dB μ V		Power Setting
	Peak	Average	
a	60.61	44.55	15.0
n HT-20	54.72	44.40	13.5
n HT-40	67.76	46.86	16.0

5460 MHz			
Operational Mode	Peak	Average	Power Setting
a	56.58	39.76	17.0
n HT-20	55.66	39.88	17.5
n HT-40	66.83	45.97	18.5

This test report may be reproduced in full only. The document may only be updated by MiCOM Labs personnel. Any changes will be noted in the Document History section of the report.



6.1.2.12.ANT19 - Radiated Band-Edge

Peak Limit 74.0 dB μ V, Peak Limit 54.0 dB μ V

5350 MHz			
Operational Mode	dB μ V		Power Setting
	Peak	Average	
a	71.42	48.39	15.0
n HT-20	65.40	45.34	14.0
n HT-40	71.45	51.86	15.0

5460 MHz			
Operational Mode	Peak	Average	Power Setting
a	60.24	46.76	17.0
n HT-20	65.05	46.70	17.5
n HT-40	71.24	51.57	18.5

This test report may be reproduced in full only. The document may only be updated by MiCOM Labs personnel. Any changes will be noted in the Document History section of the report.



Title: APIN0114, APIN0115 802.11a/b/g/n
To: FCC 47 CFR Part 15.407 & IC RSS-210
Serial #: ARUB149-U4 Rev A
Issue Date: 5th August 2013
Page: 99 of 257

6.1.2.13. Digital Emissions (30M-1 GHz)

FCC, Part 15 Subpart C §15.205/ §15.209
Industry Canada RSS-210 §2.2

Test Procedure

Testing 30M-1 GHz was performed in a 3-meter anechoic chamber using a CISPR compliant receiver. Preliminary radiated emissions were measured on every azimuth and with the receiving antenna in both horizontal and vertical polarizations. To further maximize emissions the receive antenna was varied between 1 and 4 meters. The emissions are recorded with receiver in peak hold mode. Emissions closest to the limits are measured in the quasi-peak mode with the tuned receiver using a bandwidth of 120 kHz. Only the highest emissions relative to the limit are listed. The anechoic chamber test set-up is identified in Section 6 Test Set-Up Photographs.

The EUT had two methods of powering on ac/dc converter and Power over Ethernet (POE). Both modes were tested for emissions below 1GHz.

Field Strength Calculation

The field strength is calculated by adding the Antenna Factor and Cable Loss, and subtracting Amplifier Gain from the measured reading. In this test facility, the Antenna Factor, Cable Loss, and Amplifier Gains are loaded into the Rohde & Schwarz Receiver and the corrected field strength can be read directly on the receiver.

$$FS = R + AF + CORR$$

where:

FS = Field Strength
R = Measured Receiver Input Amplitude
AF = Antenna Factor
CORR = Correction Factor = CL – AG + NFL
CL = Cable Loss
AG = Amplifier Gain

For example:

Given a Receiver input reading of 51.5dB μ V; Antenna Factor of 8.5dB; Cable Loss of 1.3dB; Falloff Factor of 0dB, an Amplifier Gain of 26dB and Notch Filter Loss of 1dB. The Field Strength of the measured emission is:

$$FS = 51.5 + 8.5 + 1.3 - 26.0 + 1 = 36.3\text{dB}\mu\text{V/m}$$

Conversion between dB μ V/m (or dB μ V) and μ V/m (or μ V) are done as:

$$\text{Level (dB}\mu\text{V/m)} = 20 * \text{Log (level (\mu\text{V/m}))}$$

$$40 \text{ dB}\mu\text{V/m} = 100\mu\text{V/m}$$

$$48 \text{ dB}\mu\text{V/m} = 250\mu\text{V/m}$$

This test report may be reproduced in full only. The document may only be updated by MiCOM Labs personnel. Any changes will be noted in the Document History section of the report.



Title: APIN0114, APIN0115 802.11a/b/g/n
To: FCC 47 CFR Part 15.407 & IC RSS-210
Serial #: ARUB149-U4 Rev A
Issue Date: 5th August 2013
Page: 100 of 257

Test Freq.	2437 MHz	Engineer	SB
Variant	Digital Emissions	Temp (°C)	24.5
Freq. Range	30 MHz - 1000 MHz	Rel. Hum.(%)	30
Power Setting	18	Press. (mBars)	1005
Antenna	integrak		
Test Notes 1	EUT Position Vertical; POE Powered		
Test Notes 2	POE Injector in the control room with ferrite clamp on Ethernet cables;		

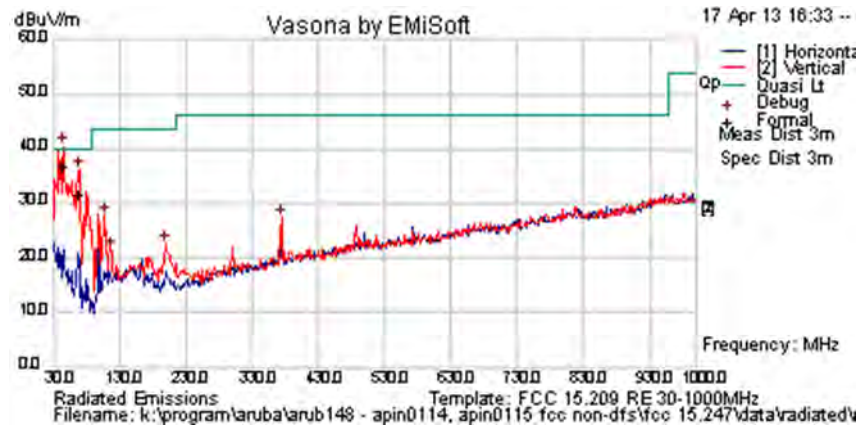

Formally measured emission peaks

Frequency MHz	Raw dBuV	Cable Loss	AF dB	Level dBuV/m	Measurement Type	Pol	Hgt cm	Azt Deg	Limit dBuV/m	Margin dB	Pass /Fail	Comments
46.665	54.6	3.7	-21.7	36.6	Quasi Max	V	99	202	40	-3.4	Pass	
68.084	51.1	3.9	-23.3	31.7	Quasi Max	V	177	331	40	-8.3	Pass	
373.833	37.1	5.4	-15.3	27.1	Peak [Scan]	V	177	331	46	-18.9	Pass	
199.074	36.3	4.6	-18.4	22.6	Peak [Scan]	V	177	331	43.5	-20.9	Pass	
107.369	42.7	4.1	-19.4	27.5	Peak [Scan]	V	177	331	43.5	-16.0	Pass	
117.157	35.0	4.2	-17.7	21.5	Peak [Scan]	V	177	331	43.5	-22.0	Pass	

Legend: DIG = Digital Device Emission; TX = Transmitter Emission; FUND = Fundamental Frequency
 NRB = Non-Restricted Band, Limit is 20 dB below Fundamental; RB = Restricted Band

This test report may be reproduced in full only. The document may only be updated by MiCOM Labs personnel. Any changes will be noted in the Document History section of the report.



Title: APIN0114, APIN0115 802.11a/b/g/n
To: FCC 47 CFR Part 15.407 & IC RSS-210
Serial #: ARUB149-U4 Rev A
Issue Date: 5th August 2013
Page: 101 of 257

Test Freq.	2437 MHz	Engineer	SB
Variant	Digital Emissions	Temp (°C)	24.5
Freq. Range	30 MHz - 1000 MHz	Rel. Hum.(%)	30
Power Setting	18	Press. (mBars)	1005
Antenna	integral		
Test Notes 1	EUT Position Horizontal; POE Powered		
Test Notes 2	POE Injector in the control room with ferrite clamp on Ethernet cables;		

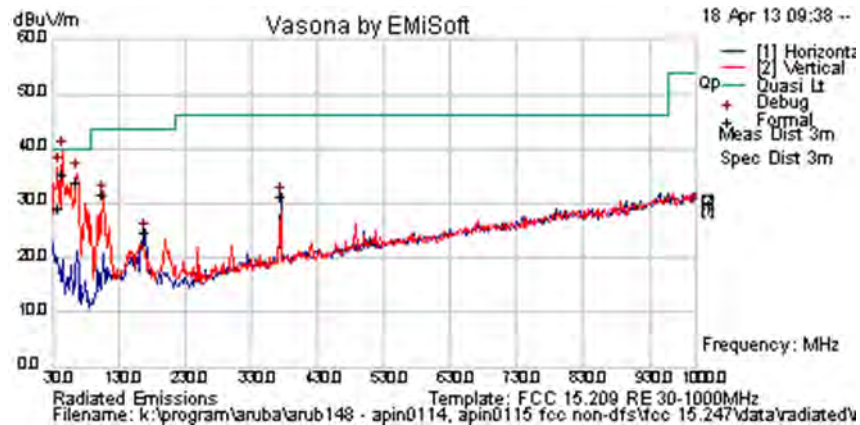

Formally measured emission peaks

Frequency MHz	Raw dBuV	Cable Loss	AF dB	Level dBuV/m	Measurement Type	Pol	Hgt cm	Azt Deg	Limit dBuV/m	Margin dB	Pass /Fail	Comments
46.682	53.3	3.7	-21.7	35.3	Quasi Max	V	119	-2	40.0	-4.7	Pass	
37.940	41.4	3.6	-16.0	29.0	Quasi Max	V	152	37	40.0	-11.0	Pass	
67.182	53.3	3.8	-23.3	33.8	Quasi Max	V	117	361	40.0	-6.2	Pass	
374.190	41.1	5.4	-15.3	31.1	Peak [Scan]	H	117	361	46.0	-14.9	Pass	
169.759	39.6	4.5	-19.4	24.8	Peak [Scan]	H	117	361	43.5	-18.7	Pass	
107.126	46.8	4.1	-19.4	31.5	Peak [Scan]	V	117	361	43.5	-12.0	Pass	

Legend: DIG = Digital Device Emission; TX = Transmitter Emission; FUND = Fundamental Frequency
 NRB = Non-Restricted Band, Limit is 20 dB below Fundamental; RB = Restricted Band

This test report may be reproduced in full only. The document may only be updated by MiCOM Labs personnel. Any changes will be noted in the Document History section of the report.



Title: APIN0114, APIN0115 802.11a/b/g/n
To: FCC 47 CFR Part 15.407 & IC RSS-210
Serial #: ARUB149-U4 Rev A
Issue Date: 5th August 2013
Page: 102 of 257

Test Freq.	2437 MHz	Engineer	SB
Variant	Digital Emissions	Temp (°C)	24.5
Freq. Range	30 MHz - 1000 MHz	Rel. Hum.(%)	30
Power Setting	18	Press. (mBars)	1005
Antenna	integral		
Test Notes 1	EUT Position Horizontal; AC/DC Powered		
Test Notes 2	AC/DC adapter on table near EUT;		

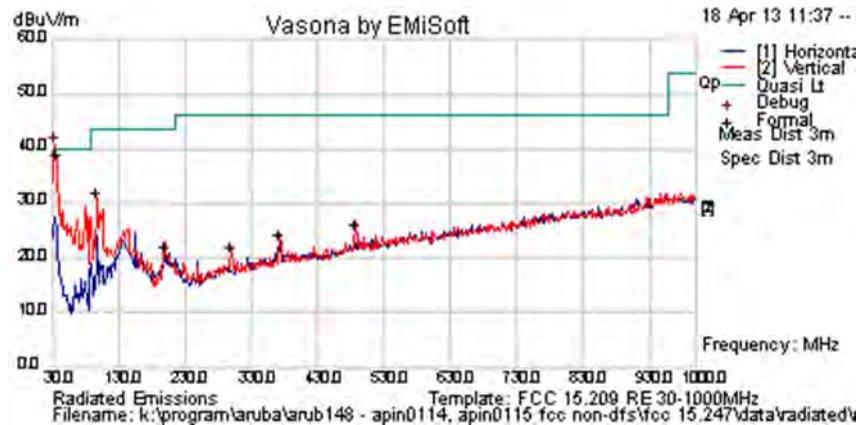

Formally measured emission peaks

Frequency MHz	Raw dBuV	Cable Loss	AF dB	Level dBuV/m	Measurement Type	Pol	Hgt cm	Azt Deg	Limit dBuV/m	Margin dB	Pass /Fail	Comments
33.888	49.0	3.6	-13.7	38.9	Quasi Max	V	103	208	40.0	-1.1	Pass	
97.839	49.9	4.1	-21.9	32.1	Peak [Scan]	V	103	320	43.5	-11.4	Pass	
200.600	36.0	4.6	-18.4	22.3	Peak [Scan]	V	103	327	43.5	-21.3	Pass	
300.511	34.2	5.1	-17.2	22.1	Peak [Scan]	V	103	352	46.0	-23.9	Pass	
372.309	34.3	5.4	-15.3	24.4	Peak [Scan]	V	103	357	46.0	-21.6	Pass	
486.686	33.0	5.8	-12.8	25.9	Peak [Scan]	V	103	365	46.0	-20.1	Pass	

Legend: DIG = Digital Device Emission; TX = Transmitter Emission; FUND = Fundamental Frequency
 NRB = Non-Restricted Band, Limit is 20 dB below Fundamental; RB = Restricted Band

This test report may be reproduced in full only. The document may only be updated by MiCOM Labs personnel. Any changes will be noted in the Document History section of the report.



Title: APIN0114, APIN0115 802.11a/b/g/n
To: FCC 47 CFR Part 15.407 & IC RSS-210
Serial #: ARUB149-U4 Rev A
Issue Date: 5th August 2013
Page: 103 of 257

Test Freq.	2437 MHz	Engineer	SB
Variant	Digital Emissions	Temp (°C)	24.5
Freq. Range	30 MHz - 1000 MHz	Rel. Hum.(%)	30
Power Setting	18	Press. (mBars)	1005
Antenna	integral		
Test Notes 1	EUT Position Vertical; AC/DC Powered		
Test Notes 2	AC/DC adapter on table near EUT;		

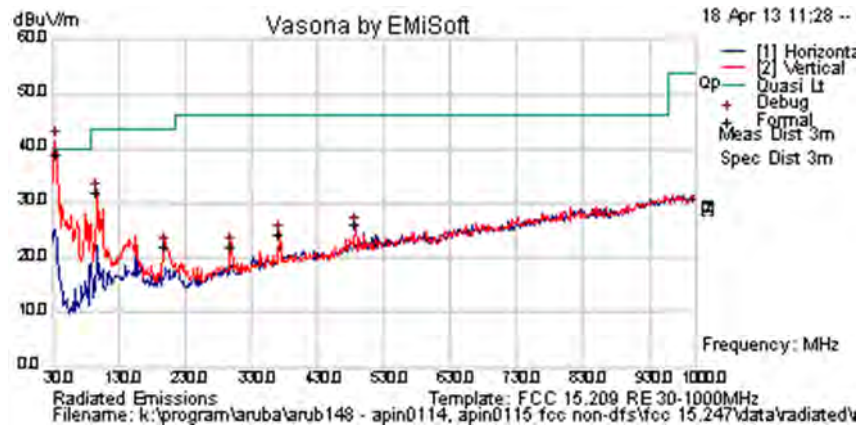

Formally measured emission peaks

Frequency MHz	Raw dBuV	Cable Loss	AF dB	Level dBuV/m	Measurement Type	Pol	Hgt cm	Azt Deg	Limit dBuV/m	Margin dB	Pass /Fail	Comments
35.122	49.0	3.6	-13.7	38.9	Quasi Max	V	103	208	40.0	-1.1	Pass	
100.839	49.9	4.1	-21.9	32.1	Peak [Scan]	V	103	320	43.5	-11.4	Pass	
200.600	36.0	4.6	-18.4	22.3	Peak [Scan]	V	103	327	43.5	-21.3	Pass	
300.511	34.2	5.1	-17.2	22.1	Peak [Scan]	V	103	352	46.0	-23.9	Pass	
372.309	34.3	5.4	-15.3	24.4	Peak [Scan]	V	103	357	46.0	-21.6	Pass	
486.686	33.0	5.8	-12.8	25.9	Peak [Scan]	V	103	365	46.0	-20.1	Pass	

Legend: DIG = Digital Device Emission; TX = Transmitter Emission; FUND = Fundamental Frequency
 NRB = Non-Restricted Band, Limit is 20 dB below Fundamental; RB = Restricted Band

This test report may be reproduced in full only. The document may only be updated by MiCOM Labs personnel. Any changes will be noted in the Document History section of the report.



Title: APIN0114, APIN0115 802.11a/b/g/n
To: FCC 47 CFR Part 15.407 & IC RSS-210
Serial #: ARUB149-U4 Rev A
Issue Date: 5th August 2013
Page: 104 of 257

Test Freq.	2437 MHz	Engineer	JMH
Variant	Digital Emissions	Temp (°C)	29
Freq. Range	30 MHz - 1000 MHz	Rel. Hum.(%)	32
Power Setting	18	Press. (mBars)	1002
Antenna	13B		
Test Notes 1	EUT Position Vertical; AC/DC Powered		
Test Notes 2	AC/DC adapter on table near EUT;		

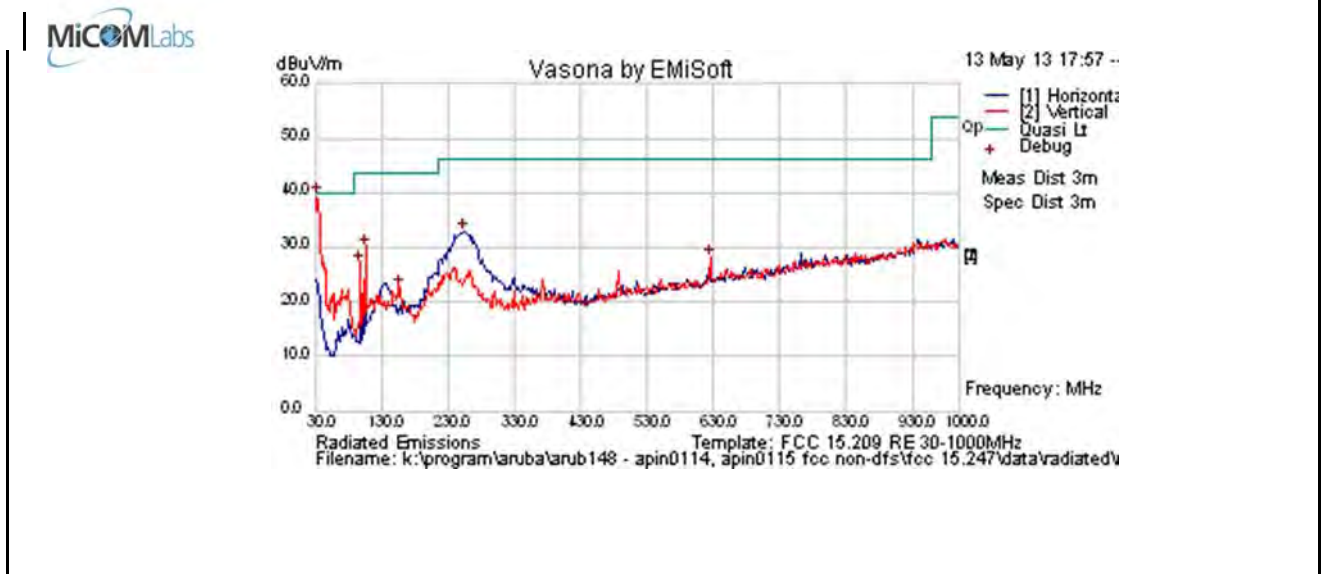

Formally measured emission peaks

Frequency MHz	Raw dBuV	Cable Loss	AF dB	Level dBuV/m	Measurement Type	Pol	Hgt cm	Azt Deg	Limit dBuV/m	Margin dB	Pass /Fail	Comments
33.532	45.0	3.5	-12.5	36.0	Quasi Max	V	103	17	40.0	-4.0	Pass	
254.555	47.0	4.9	-19.0	32.9	Peak [Scan]	H	98	0	46.0	-13.1	Pass	
105.758	45.6	4.1	-19.7	30.0	Peak [Scan]	V	98	0	43.5	-13.5	Pass	
98.135	44.5	4.1	-21.8	26.8	Peak [Scan]	V	98	0	43.5	-16.7	Pass	
625.048	32.6	6.3	-11.0	27.9	Peak [Scan]	V	98	0	46.0	-18.1	Pass	
158.040	36.9	4.4	-18.8	22.5	Peak [Scan]	V	98	0	43.5	-21.0	Pass	

Legend: DIG = Digital Device Emission; TX = Transmitter Emission; FUND = Fundamental Frequency
 NRB = Non-Restricted Band, Limit is 20 dB below Fundamental; RB = Restricted Band

This test report may be reproduced in full only. The document may only be updated by MiCOM Labs personnel. Any changes will be noted in the Document History section of the report.



Specification

Limits

§15.205 (a) Except as shown in paragraph (d) of 15.205 (a), only spurious emissions are permitted in any of the frequency bands listed.

§15.205 (a) Except as shown in paragraphs (d) and (e) of this section, the field strength of emissions appearing within these frequency bands shall not exceed the limits shown in Section §15.209. At frequencies equal to or less than 1000 MHz, compliance with the limits in Section 15.209 shall be demonstrated using measurement instrumentation employing a CISPR quasi-peak detector. Above 1000 MHz, compliance with the emission limits in Section 15.209 shall be demonstrated based on the average value of the measured emissions. The provisions in Section 15.35 apply to these measurements.

§15.209 (a) Except as provided elsewhere in this subpart, the emissions from an intentional radiator shall not exceed the field strength levels specified in the following table.

§15.209 (a) and RSS-Gen §2.2 Limit Matrix

Frequency(MHz)	Field Strength (µV/m)	Field Strength (dBµV/m)	Measurement Distance (meters)
30-88	100	40.0	3
88-216	150	43.5	3
216-960	200	46.0	3
Above 960	500	54.0	3

Laboratory Measurement Uncertainty for Radiated Emissions

Measurement uncertainty	+5.6/ -4.5 dB
-------------------------	---------------

Traceability

Method	Test Equipment Used
Measurements were made per work instruction WI-03 'Measurement of Radiated Emissions'	0088, 0158, 0134, 0304, 0311, 0315, 0310, 0312

This test report may be reproduced in full only. The document may only be updated by MiCOM Labs personnel. Any changes will be noted in the Document History section of the report.

6.1.3. AC Wireline Conducted Emissions (150 kHz – 30 MHz)

FCC, Part 15 Subpart C §15.207
Industry Canada RSS-Gen §7.2.2

Test Procedure

The EUT is configured in accordance with ANSI C63.4. The conducted emissions are measured in a shielded room with a spectrum analyzer in peak hold in the first instance. Emissions closest to the limit are measured in the quasi-peak mode (QP) with the tuned receiver using a bandwidth of 9 kHz. The emissions are maximized further by cable manipulation. The highest emissions relative to the limit are listed.

Measurement Results for AC Wireline Conducted Emissions (150 kHz – 30 MHz)

Ambient conditions.

Temperature: 17 to 23 °C Relative humidity: 31 to 57 % Pressure: 999 to 1012 mbar

Test Measurement Set up

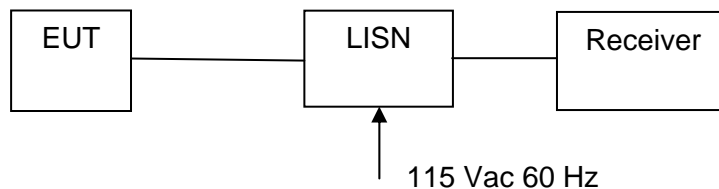

Measurement set up for AC Wireline Conducted Emissions Test

Measurement Results for AC Wireline Conducted Emissions (150 kHz – 30 MHz)

Ambient conditions.

Temperature: 17 to 23 °C Relative humidity: 31 to 57 % Pressure: 999 to 1012 mbar