



MEASUREMENT REPORT

FCC PART 15 Subpart C / ZigBee

FCC ID: Q9DAPEX058457
Applicant: Hewlett Packard Enterprise Company
Application Type: Certification
Product: ACCESS POINT
Model No.: APEX0587, APEX0584, APEX0585
TradeMark:  
FCC Classification: Digital Transmission System (DTS)
FCC Rule Part(s): Part15 Subpart C (Section 15.247)
Test Date: October 31, 2021 ~ January 06, 2022

Reviewed By:

Paddy Chen

(Paddy Chen)

Approved By:

Chenz Ker

(Chenz Ker)



Testing Laboratory
3261

The test results relate only to the samples tested.

This equipment has been shown to be capable of compliance with the applicable technical standards as indicated in the measurement report and was tested in accordance with the measurement procedures specified in ANSI C63.10-2013. Test results reported herein relate only to the item(s) tested.

The test report shall not be reproduced except in full without the written approval of MRT Technology (Taiwan) Co., Ltd.

Revision History

Report No.	Version	Description	Issue Date	Note
2105TW0005-U2	V1.0	Initial Report	01-12-2022	Valid

CONTENTS

Description	Page
General Information.....	5
1. INTRODUCTION	6
1.1. Scope	6
1.2. MRT Test Location	6
2. PRODUCT INFORMATION	7
2.1. Equipment Description.....	7
2.2. Product Specification Subjective to this Report.....	7
2.3. Working Frequencies for this report	7
2.4. Description of Available Antennas	8
2.5. Description of EUT Filter	10
2.6. Duty Cycle	11
2.7. Description of Test Configuration and Software	12
2.8. EMI Suppression Device(s)/Modifications	13
2.9. Labeling Requirements	13
3. DESCRIPTION of TEST	14
3.1. Evaluation Procedure	14
3.2. AC Line Conducted Emissions.....	14
3.3. Radiated Emissions	15
4. ANTENNA REQUIREMENTS.....	16
5. TEST EQUIPMENT CALIBRATION DATE	17
6. MEASUREMENT UNCERTAINTY.....	19
7. TEST RESULT	20
7.1. Summary	20
7.2. 6dB Bandwidth Measurement.....	21
7.2.1. Test Limit.....	21
7.2.2. Test Procedure used.....	21
7.2.3. Test Setting	21
7.2.4. Test Setup	21
7.2.5. Test Result	22
7.3. Output Power Measurement	23
7.3.1. Test Limit.....	23
7.3.2. Test Procedure Used.....	23
7.3.3. Test Setting	23
7.3.4. Test Setup	24
7.3.5. Test Result	25
7.4. Power Spectral Density Measurement	28
7.4.1. Test Limit.....	28

7.4.2. Test Procedure Used	28
7.4.3. Test Setting	28
7.4.4. Test Setup	28
7.4.5. Test Result	29
7.5. Conducted Band Edge and Out-of-Band Emissions.....	30
7.5.1. Test Limit	30
7.5.2. Test Procedure Used	30
7.5.3. Test Setting	30
7.5.4. Test Setup	31
7.5.5. Test Result	32
7.6. Radiated Spurious Emission Measurement	37
7.6.1. Test Limit	37
7.6.2. Test Procedure Used	37
7.6.3. Test Setting	37
7.6.4. Test Setup	39
7.6.5. Test Result	40
7.7. Radiated Restricted Band Edge Measurement	82
7.7.1. Test Limit	82
7.7.2. Test Procedure Used	83
7.7.3. Test Setting	83
7.7.4. Test Setup	84
7.7.5. Test Result	85
7.8. AC Conducted Emissions Measurement.....	109
7.8.1. Test Limit	109
7.8.2. Test Setup	109
7.8.3. Test Result	110
8. CONCLUSION.....	112
Appendix A - Test Setup Photograph.....	113
Appendix B - EUT Photograph.....	114

General Information

Applicant	Hewlett Packard Enterprise Company
Applicant Address	3333 Scott Blvd, Santa Clara, CA 95054, USA
Manufacturer	Hewlett Packard Enterprise Company
Manufacturer Address	3333 Scott Blvd, Santa Clara, CA 95054, USA
Test Site	MRT Technology (Taiwan) Co., Ltd
Test Site Address	No. 38, Fuxing Second Rd., Guishan Dist., Taoyuan City 333, Taiwan (R.O.C)
MRT FCC Registration No.	291082
FCC Rule Part(s)	Part 15.247
Test Device Serial No.	APEX0585: CNM4L1M012 APEX0587: CNM7L1N00T APEX0584: CNM5L1L01S

Test Facility / Accreditations

1. MRT facility is a FCC registered (Reg. No. 291082) test facility with the site description report on file and is designated by the FCC as an Accredited Test Firm.
2. MRT facility is an IC registered (MRT Reg. No. 21723) test laboratory with the site description on file at Industry Canada.
3. MRT Lab is accredited to ISO 17025 by the Taiwan Accreditation Foundation (TAF Cert. No. 3261) in EMC, Telecommunications and Radio testing for FCC (Designation Number: TW3261), Industry Taiwan, EU and TELEC Rules.

1. INTRODUCTION

1.1. Scope

Measurement and determination of electromagnetic emissions (EMC) of radio frequency devices including intentional and/or unintentional radiators for compliance with the technical rules and regulations of the Federal Communications Commission and the Innovation, Science and Economic Development Canada and Certification and Engineering Bureau.

1.2. MRT Test Location

The map below shows the location of the MRT LABORATORY, its proximity to the Taoyuan City. These measurement tests were conducted at the MRT Technology (Taiwan) Co., Ltd. Facility located at No.38, Fuxing 2nd Rd., Guishan Dist., Taoyuan City 33377, Taiwan (R.O.C).

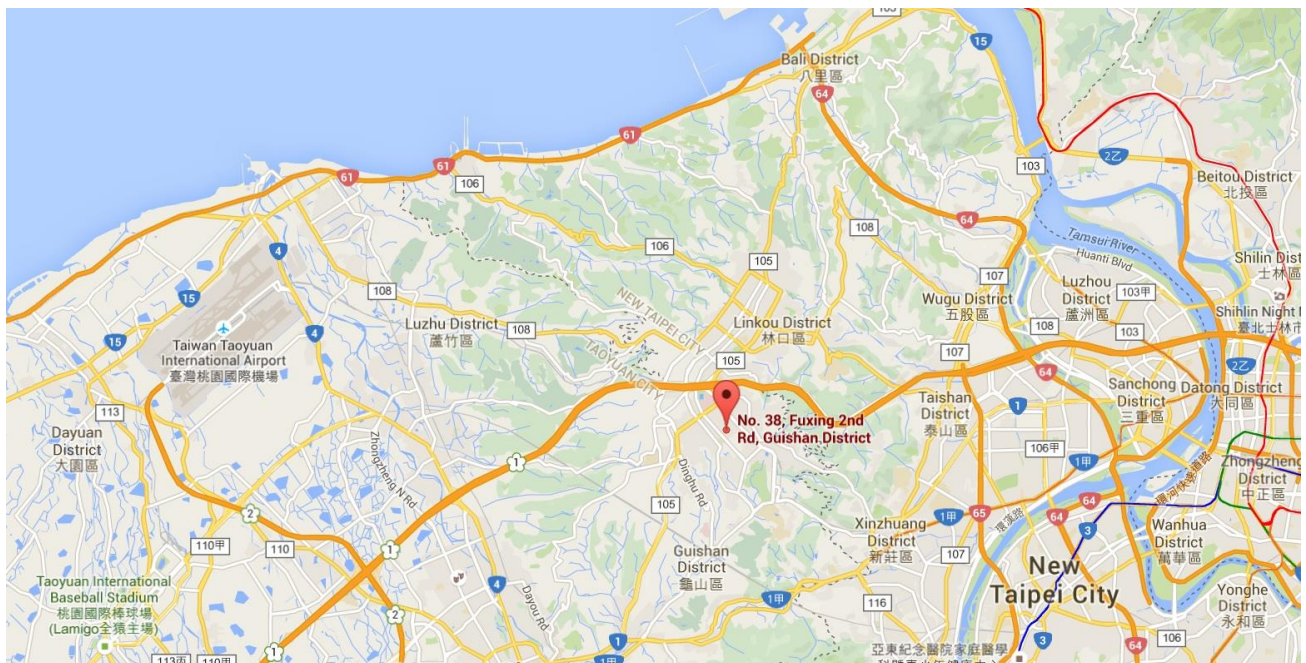

2. PRODUCT INFORMATION

2.1. Equipment Description

Product Name	ACCESS POINT
Model No.	APEX0587, APEX0584, APEX0585
Software Version	v1.0
Wi-Fi Specification	802.11a/b/g/n/ac/ax
Bluetooth Specification	v5.0 single mode, BLE only
Zigbee Specification	802.15.4
Operating Temperature	-40 ~ 65 °C
Power Type	AC Cable or PoE input
Operating Environment	Outdoor Use
Antenna Information	Refer to Section 2.4
Remark: Note 1: The difference between three models is that the EUT use different antenna and appearance, other hardware and software are the same. Each model has its own power parameter value. Note 2: The information of EUT was provided by the manufacturer, and the accuracy of the information shall be the responsibility of the manufacturer.	

2.2. Product Specification Subjective to this Report

Zigbee Specification	802.15.4
Frequency Range	2405 ~ 2480 MHz
Channel Number	16
Type of Modulation	O-QPSK

Note: For other features of this EUT, test report will be issued separately.

2.3. Working Frequencies for this report

Channel	Frequency	Channel	Frequency	Channel	Frequency
11	2405 MHz	12	2410 MHz	13	2415 MHz
14	2420 MHz	15	2425 MHz	16	2430 MHz
17	2435 MHz	18	2440 MHz	19	2445 MHz
20	2450 MHz	21	2455 MHz	22	2460 MHz
23	2465 MHz	24	2470 MHz	25	2475 MHz
26	2480 MHz	--	--	--	--

2.4. Description of Available Antennas

APEX0585

Polarization	Frequency Band (GHz)	Max Peak Gain (dBi)	30 Degree ANT Gain (dBi)	CDD Directional Gain (dBi)		BF Gain (dBi)
				For Power	For PSD	
Wi-Fi Internal Antenna (4*4 MIMO)						
Omni (Note 2)	2.4 ~ 2.5	3.0	N/A	3.00	6.01	6.01
	5.15 ~ 5.85	4.5	-5.00	4.50	7.51	7.51
Bluetooth / ZigBee Internal Antenna						
Omni	2.4 ~ 2.5	4.8				

APEX0584

Polarization	Frequency Band (GHz)	Model No.	Max Peak Gain (dBi)	30 Degree ANT Gain (dBi)	BF Gain (dBi)	CDD Directional Gain (dBi)	
						For Power	For PSD
Wi-Fi External Antenna List (4*4 MIMO)							
Omni (Note 2)	2.4 ~ 2.5	ANT-2x2-2005	5.0	N/A	8.01	5.0	8.01
Omni (Note 2)	5.15 ~ 5.85	ANT-2x2-5005	5.0	0	8.01	5.0	8.01
Omni (Note 2)	5.15 ~ 5.85	ANT-2x2-5010	10.0	0	13.01	10.0	13.01
Directional (Note 2)	2.4 ~ 2.5	ANT-2x2-2714	14.0	N/A	17.01	14.0	17.01
Directional (Note 2)	2.4 ~ 2.5	ANT-2x2-2314	14.0	N/A	14.00	14.0	14.00
Directional (Note 2)	5.15 ~ 5.85	ANT-3x3-5712	11.5	1.5	14.51	11.5	14.51
Directional (Note 2)	5.15 ~ 5.85	ANT-4x4-5314	14.0	6.0	17.01	14.0	17.01
Directional (Note 2)	2.4 ~ 2.5	ANT-4x4-D608	7.5	N/A	10.51	7.5	10.51
	5.15 ~ 5.85		7.5	4.5	10.51	7.5	10.51
Directional (Note 2)	2.4 ~ 2.5	ANT-4x4-D100	5.0	N/A	8.01	5.0	8.01
	5.15 ~ 5.85		5.0	4.0	8.01	5.0	8.01
Bluetooth / ZigBee Internal Antenna							
Omni	2.4 ~ 2.5	5.0					

APEX0587

Polarization	Frequency Band (GHz)	Max Peak Gain (dBi)	30 Degree ANT Gain (dBi)	CDD Directional Gain (dBi)		BF Gain (dBi)
				For Power	For PSD	
Wi-Fi Internal Antenna (4*4 MIMO)						
Omni (Note 2)	2.4 ~ 2.5	5.7	N/A	5.70	8.71	8.71
	5.15 ~ 5.85	5.2	5.2	5.20	8.21	8.21
Bluetooth / ZigBee Internal Antenna						
Omni	2.4 ~ 2.5	6.3				

Note:

1. The EUT supports Cyclic Delay Diversity (CDD) mode, and CDD signals are correlated.

For CDD transmissions, directional gain is calculated as follows, $N_{ANT} = 2$, $N_{SS} = 1$.

If all antennas have the same gain, G_{ANT} , Directional gain = $G_{ANT} + \text{Array Gain}$, where Array Gain is as follows.

- For power spectral density (PSD) measurements on all devices,

$$\text{Array Gain} = 10 \log(N_{ANT}/N_{SS}) \text{ dB} = 3.01;$$

- For power measurements on IEEE 802.11 devices,

$$\text{Array Gain} = 0 \text{ dB for } N_{ANT} \leq 4;$$

The EUT also supports Beam Forming mode, and the Beam Forming support 802.11n/ac/ax, not include 802.11a/b/g.

2. These antennas are cross polarized design, the detail refer to antenna specification. Directional gain calculation refer to KDB 662911 section F)2)c).

3. For APEX0584, low gain antenna (ANT-2x2-2005 & ANT-2x2-5005) was selected to perform all RF testing that can get maximum power setting, high gain different type antenna (ANT-2x2-2314 & ANT-4x4-5314) was selected to perform radiated spurious emission and band edge testing. High gain antenna power setting will be reduced according to difference value of antenna gain declared by applicant.

2.5. Description of EUT Filter

Filter	Specification	Remark
Wi-Fi		
Filter 1#	Band Pass Filter (2412-2472)	Allowing any transmission on all channels
Filter 2#	Band Pass Filter (2402-2447)	Allowing any transmission on 20MHz channels 1 thru 6.
Filter 3#	Band Pass Filter (2452-2472)	Allowing any transmission on 20MHz channel 11
Bluetooth & ZigBee		
Filter 4#	Band Pass Filter (2402-2480)	Allowing any transmission on all channels
Filter 5#	Band Pass Filter (2402-2426)	Allowing any transmission on channel 2402 ~ 2426 MHz (BLE) and channel 2405 ~ 2425 MHz (ZigBee)
Filter 6#	Band Pass Filter (2478-2482)	Allowing transmission on channel 2480 MHz (BLE) and 2480 MHz (ZigBee)

Working Group

Groups	Remark
Filter 1# or Filter 4#	Filter 1# or Filter 4# can work alone
Filter 2# and Filter 6#	Transmission simultaneously
Filter 5# and Filter 5#	Transmission simultaneously
Note: Filter groups on the 2.4GHz Wi-Fi and BLE/ZigBee outputs to prevent reverse IMD when both 2.4GHz Wi-Fi and BLE/ZigBee are transmitting simultaneously	

2.6. Duty Cycle

The maximum achievable duty cycles for all modes were determined based on measurements performed on a spectrum analyzer in zero-span mode with RBW = 8MHz, VBW = 50MHz. The RBW and VBW were both greater than $50/T$, where T is the minimum transmission duration, and the number of sweep points across T was greater than 100. The duty cycles are as follows:

Test Mode	T (Transmission Duration)	Duty Cycle
802.15.4	848.7us	87.70%

Note 1: This duty cycle was only suitable for continuous transmission of signals via commands.

Note 2: The manufacturer, declared that the ZigBee operation, when implemented, will be limited to a max duty cycle of 10% or less in any 100ms period. So -20dB correction factor was used during peak and average band edge testing.

2.7. Description of Test Configuration and Software

The device was tested per the guidance ANSI C63.10-2013 was used to reference the appropriate EUT setup.

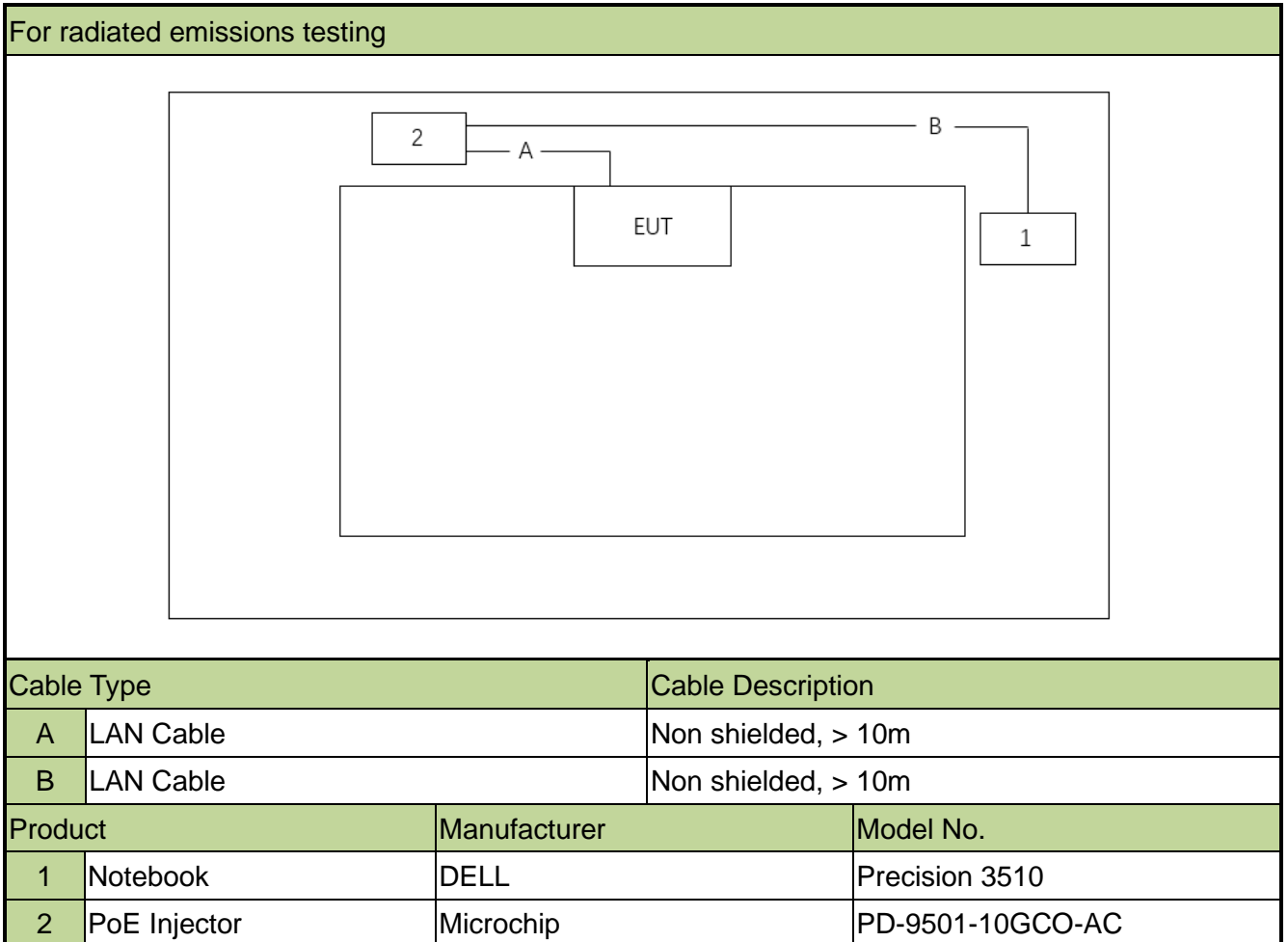

For AC line conducted testing

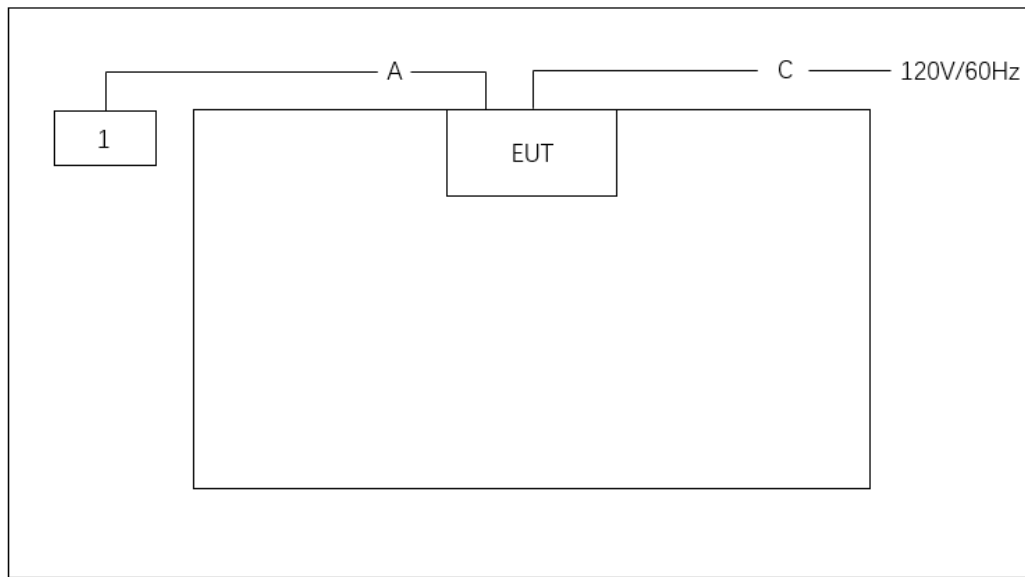

Cable Type		Cable Description	
A	LAN Cable	Non shielded, > 10m	
C	Power Cable	Non shielded, 1.25m	
Product		Manufacturer	Model No.
1	Notebook	DELL	Precision 3510

Note 1: The test utility software used during testing was “telnet.exe” and command was provided by the manufacturer.

Note 2: Detail power setting refer to operation description.

2.8. EMI Suppression Device(s)/Modifications

No EMI suppression device(s) were added and/or no modifications were made during testing.

2.9. Labeling Requirements

Per 2.1074 & 15.19; Docket 95-19

The label shall be permanently affixed at a conspicuous location on the device; instruction manual or pamphlet supplied to the user and be readily visible to the purchaser at the time of purchase.

However, when the device is so small wherein placement of the label with specified statement is not practical, only the FCC ID must be displayed on the device per Section 15.19(a)(5). Please see attachment for FCC ID label and label location.

3. DESCRIPTION of TEST

3.1. Evaluation Procedure

The measurement procedure described in the document titled “American National Standard of Procedures for Compliance Testing of Unlicensed Wireless Devices” (ANSI C63.10-2013) was used in the measurement.

3.2. AC Line Conducted Emissions

The line-conducted facility is located inside an 8'x4'x4' shielded enclosure. A 1m x 2m wooden table 80cm high is placed 40cm away from the vertical wall and 80cm away from the sidewall of the shielded room. Two 10kHz-30MHz, 50Ω/50uH Line-Impedance Stabilization Networks (LISNs) are bonded to the shielded room floor. Power to the LISNs is filtered by external high-current high-insertion loss power line filters. These filters attenuate ambient signal noise from entering the measurement lines. These filters are also bonded to the shielded enclosure.

The EUT is powered from one LISN and the support equipment is powered from the second LISN. All interconnecting cables more than 1 meter were shortened to a 1 meter length by non-inductive bundling (serpentine fashion) and draped over the back edge of the test table. All cables were at least 40cm above the horizontal reference ground-plane. Power cables for support equipment were routed down to the second LISN while ensuring that that cables were not draped over the second LISN.

Sufficient time for the EUT, support equipment, and test equipment was allowed in order for them to warm up to their normal operating condition. The RF output of the LISN was connected to the receiver and exploratory measurements were made to determine the frequencies producing the maximum emission from the EUT. The receiver was scanned from 150kHz to 30MHz. The detector function was set to peak mode for exploratory measurements while the bandwidth of the analyzer was set to 9kHz. The EUT, support equipment, and interconnecting cables were arranged and manipulated to maximize each emission. Each emission was also maximized by varying: power lines, the mode of operation or data exchange speed, or support equipment whichever determined the worst-case emission. Once the worst case emissions have been identified, the one EUT cable configuration/arrangement and mode of operation that produced these emissions are used for final measurements on the same test site. The analyzer is set to CISPR quasi-peak and average detectors with a 9kHz resolution bandwidth for final measurements.

An extension cord was used to connect to a single LISN which powered by EUT. The extension cord was calibrated with LISN, the impedance and insertion loss are compliance with the requirements as stated in ANSI C63.10-2013.

3.3. Radiated Emissions

The radiated test facilities consisted of an indoor 3 meter semi-anechoic chamber used for final measurements and exploratory measurements, when necessary. The measurement area is contained within the semi-anechoic chamber which is shielded from any ambient interference. For measurements above 1GHz absorbers are arranged on the floor between the turn table and the antenna mast in such a way so as to maximize the reduction of reflections. For measurements below 1GHz, the absorbers are removed. A MF Model 210SS turntable is used for radiated measurement. It is a continuously rotatable, remotecontrolled, metallic turntable and 2 meters (6.56 ft.) in diameter. The turn table is flush with the raised floor of the chamber in order to maintain its function as a ground plane. An 80cm high PVC support structure is placed on top of the turntable.

For all measurements, the spectrum was scanned through all EUT azimuths and from 1 to 4 meter receive antenna height using a broadband antenna from 30MHz up to the upper frequency shown in 15.33(b)(1) depending on the highest frequency generated or used in the device or on which the device operates or tunes. For frequencies above 1GHz, linearly polarized double ridge horn antennas were used. For frequencies below 30MHz, a calibrated loop antenna was used. When exploratory measurements were necessary, they were performed at 1 meter test distance inside the semi-anechoic chamber using broadband antennas, broadband amplifiers, and spectrum analyzers to determine the frequencies and modes producing the maximum emissions. Sufficient time for the EUT, support equipment, and test equipment was allowed in order for them to warm up to their normal operating condition. The test set-up for frequencies below 1GHz was placed on top of the 0.8 meter high, 1 x 1.5 meter table; and test set-up for frequencies 1-40GHz was placed on top of the 1.5 meter high, 1 x 1.5 meter table. The EUT, support equipment, and interconnecting cables were arranged and manipulated to maximize each emission. Appropriate precaution was taken to ensure that all emissions from the EUT were maximized and investigated. The system configuration, clock speed, mode of operation or video resolution, if applicable, turntable azimuth, and receive antenna height was noted for each frequency found.

Final measurements were made in the semi-anechoic chamber using calibrated, linearly polarized broadband and horn antennas. The test setup was configured to the setup that produced the worst case emissions. The spectrum analyzer was set to investigate all frequencies required for testing to compare the highest radiated disturbances with respect to the specified limits. The turntable containing the EUT was rotated through 360 degrees and the height of the receive antenna was varied 1 to 4 meters and stopped at the azimuth and height producing the maximum emission. Each emission was maximized by changing the orientation of the EUT through three orthogonal planes and changing the polarity of the receive antenna, whichever produced the worst-case emissions. According to 3dB Beam-Width of horn antenna, the horn antenna should be always directed to the EUT when rising height.

4. ANTENNA REQUIREMENTS

Excerpt from §15.203 of the FCC Rules/Regulations:

“An intentional radiator antenna shall be designed to ensure that no antenna other than that furnished by the responsible party can be used with the device. The use of a permanently attached antenna or of an antenna that uses a unique coupling to the intentional radiator shall be considered sufficient to comply with the provisions of this section.”

Conclusion:

The product is defined as the professional installation of equipment by the manufacturer, there is no necessary to comply with the requirement of §15.203.

5. TEST EQUIPMENT CALIBRATION DATE

Conducted Emissions - SR2

Instrument	Manufacturer	Type No.	Asset No.	Cali. Interval	Cali. Due Date
Two-Line V-Network	R&S	ENV 216	MRTTWA00019	1 year	2022/3/23
Two-Line V-Network	R&S	ENV 216	MRTTWA00020	1 year	2022/4/24
8-Wire ISN (T8)	R&S	ENY81	MRTTWA00018	1 year	2022/5/30
EMI Test Receiver	R&S	ESR3	MRTTWA00045	1 year	2022/5/25
Temperature/Humidity Meter	TFA	35.1083	MRTTWA00050	1 year	2022/6/3

Radiated Emissions - AC1/AC2

Instrument	Manufacturer	Type No.	Asset No.	Cali. Interval	Cali. Due Date
Active Loop Antenna	SCHWARZBECK	FMZB 1519B	MRTTWA00002	1 year	2022/4/27
Broadband TRILOG Antenna	SCHWARZBECK	VULB 9162	MRTTWA00001	1 year	2022/10/4
Broadband Horn Antenna	SCHWARZBECK	BBHA 9120D	MRTTWA00003	1 year	2022/4/24
Broadband Horn Antenna	RFSPIN	DRH18-E	MRTTWA00087	1 year	2022/6/28
Broadband Horn Antenna	SCHWARZBECK	BBHA 9170	MRTTWA00004	1 year	2022/4/24
Broadband Preamplifier	SCHWARZBECK	BBV 9718	MRTTWA00005	1 year	2022/4/24
Broadband Preamplifier	EMC Instruments corporation	EMC118A45S E	MRTTWA00088	1 year	2022/6/28
Broadband Amplifier	SCHWARZBECK	BBV 9721	MRTTWA00006	1 year	2022/4/24
Signal Analyzer	R&S	FSV40	MRTTWA00007	1 year	2022/3/23
EMI Test Receiver	R&S	ESR3	MRTTWA00009	1 year	2022/3/24
EXA Signal Analyzer	KEYSIGHT	N9010A	MRTTWA00012	1 year	2021/11/14
				1 year	2022/11/13
Antenna Cable	HUBERSUHNER	SF106	MRTTWE00010	1 year	2022/6/28
Cable	Rosnol	K1K50-UP026 4-K1K50-4M	MRTTWE00012	1 year	2022/6/20
Antenna Cable	HUBERSUHNER	SF106	MRTTWE00034	1 year	2022/6/28
Cable	HUBERSUHNER	EMC105-NM- NM-3000	MRTTWE00035	1 year	2022/6/28
Temperature/Humidity Meter	TFA	35.1078.10.IT	MRTTWA00032	1 year	2022/6/6

Conducted Test Equipment - SR2

Instrument	Manufacturer	Type No.	Asset No.	Cali. Interval	Cali. Due Date
X-Series USB Peak and Average Power Sensor	KEYSIGHT	U2021XA	MRTTWA00014	1 year	2022/4/21
EXA Signal Analyzer	KEYSIGHT	N9010A	MRTTWA00012	1 year	2021/11/14
				1 year	2022/11/13
EXA Signal Analyzer	KEYSIGHT	N9010B	MRTTWA00074	1 year	2022/7/19
Attenuator	WTI	218FS-20	MRTTWE00027	1 year	2022/6/16
Attenuator	WTI	218FS-10	MRTTWE00028	1 year	2022/6/16
Attenuator	WTI	218FS-06	MRTTWE00029	1 year	2022/6/16
Temperature/Humidity Meter	TFA	35.1083	MRTTWA00050	1 year	2022/6/3

Test Software

Software	Version	Function
e3	9.160520a	EMI Test Software

6. MEASUREMENT UNCERTAINTY

Where relevant, the following test uncertainty levels have been estimated for tests performed on the EUT as specified in CISPR 16-4-2. This uncertainty represents an expanded uncertainty expressed at approximately the 95% confidence level using a coverage factor of $k = 2$.

AC Conducted Emission Measurement
Measuring Uncertainty for a Level of Confidence of 95% ($U=2Uc(y)$): 150kHz~30MHz: 2.53dB
Radiated Emission Measurement
Measuring Uncertainty for a Level of Confidence of 95% ($U=2Uc(y)$): 9kHz ~ 1GHz: 4.25dB 1GHz ~ 40GHz: 4.45dB
Conducted Power
Measuring Uncertainty for a Level of Confidence of 95% ($U=2Uc(y)$): ± 0.84 dB
Conducted Spurious Emission
Measuring Uncertainty for a Level of Confidence of 95% ($U=2Uc(y)$): ± 2.65 dB
Occupied Bandwidth
Measuring Uncertainty for a Level of Confidence of 95% ($U=2Uc(y)$): 3.3%
Temp. / Humidity
Measuring Uncertainty for a Level of Confidence of 95% ($U=2Uc(y)$): $\pm 0.82^{\circ}\text{C} / \pm 3\%$

7. TEST RESULT

7.1. Summary

FCC Section(s)	Test Description	Test Limit	Test Condition	Test Result	Reference
15.247(a)(2)	6dB Bandwidth	$\geq 500\text{kHz}$	Conducted	Pass	Section 7.2
15.247(b)(3)	Output Power	$\leq 30\text{dBm}$		Pass	Section 7.3
15.247(e)	Power Spectral Density	$\leq 8\text{dBm}/3\text{kHz}$		Pass	Section 7.4
15.247(d)	Band Edge / Out-of-Band Emissions	$\geq 20\text{dBc (Peak)}$		Pass	Section 7.5
15.205 15.209	General Field Strength (Restricted Bands and Radiated Emission)	Emissions in restricted bands must meet the radiated limits detailed in 15.209	Radiated	Pass	Section 7.6 & 7.7
15.207	AC Conducted Emissions 150kHz - 30MHz	< FCC 15.207 limits	Line Conducted	Pass	Section 7.8

Notes:

- The analyzer plots shown in this section were all taken with a correction table loaded into the analyzer. The correction table was used to account for the losses of the cables and attenuators used as part of the system to connect the EUT to the analyzer at all frequencies of interest.
- All modes of operation and data rates were investigated. For radiated emission test, every axis (X, Y, Z) was also verified. The test results shown in the following sections represent the worst case emissions.
- Determining compliance is based on the test results met the regulation limits or requirements declared by clients, and the test results don't take into account the value of measurement uncertainty.
- For three models, conducted test data is the same, radiated test data is separate.

Test Items	Filter 4#	Filter 5#	Filter 6#
6dB Bandwidth	•		
Output Power	•	•	•
Power Spectral Density	•		
Band Edge / Out-of-Band Emissions	•	•	•
Radiated Spurious Emission	•	•	•
Radiated Band Edge	•	•	•
AC Conducted Emissions 150kHz - 30MHz	•		

7.2. 6dB Bandwidth Measurement

7.2.1. Test Limit

The minimum 6dB bandwidth shall be at least 500 kHz.

7.2.2. Test Procedure used

ANSI C63.10-2013 Section 11.8

7.2.3. Test Setting

1. The Spectrum's automatic bandwidth measurement capability was used to perform the 6dB bandwidth measurement. The "X" dB bandwidth parameter was set to $X = 6$. The bandwidth measurement was not influenced by any intermediate power nulls in the fundamental emission.
2. Set RBW = 100 kHz
3. VBW $\geq 3 \times$ RBW
4. Detector = Peak
5. Trace mode = max hold
6. Sweep = auto couple
7. Allow the trace was allowed to stabilize

7.2.4. Test Setup

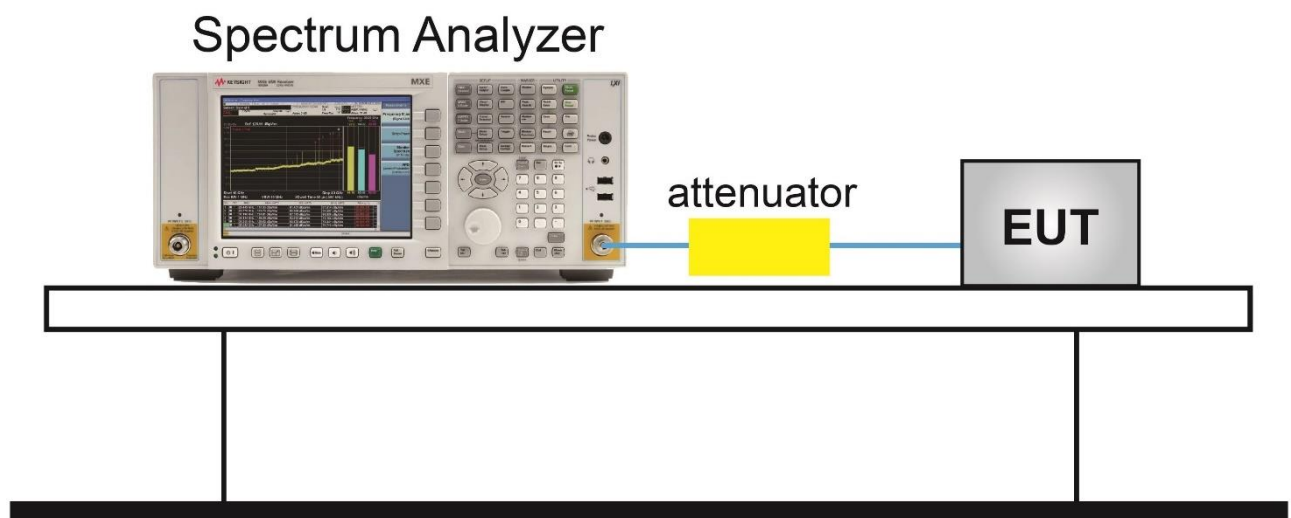

7.2.5. Test Result

Product	ACCESS POINT	Test Engineer	Eric Lin
Test Site	SR2	Test Date	2021/10/31
Model No.	APEX0587		

Test Mode	Modulation Mode	Channel No.	Frequency (MHz)	6dB Bandwidth (MHz)	Limit (MHz)	Result
802.15.4	O-QPSK	11	2405	1.145	≥0.5	Pass
802.15.4	O-QPSK	18	2440	1.119	≥0.5	Pass
802.15.4	O-QPSK	26	2480	1.121	≥0.5	Pass

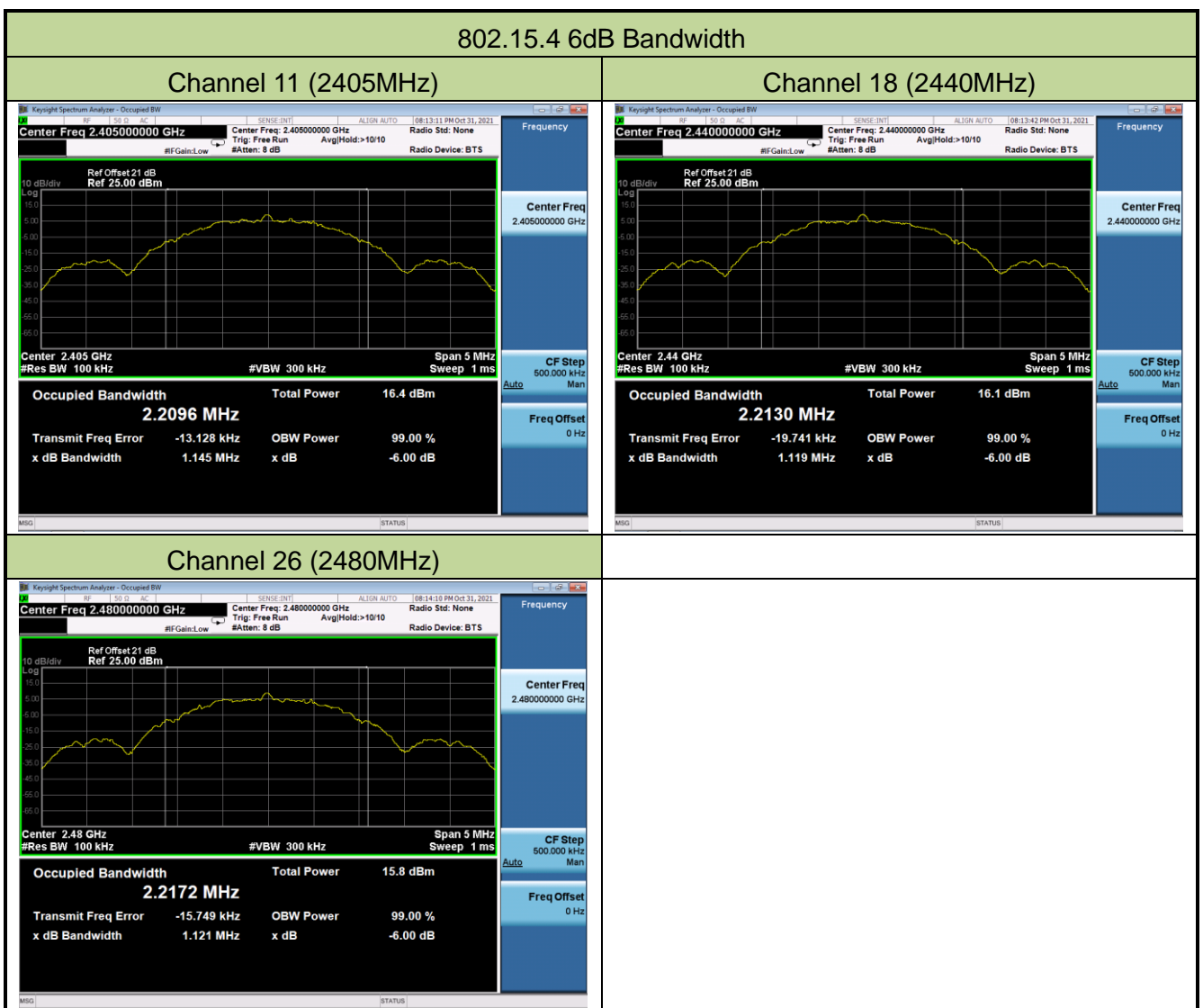

7.3. Output Power Measurement

7.3.1. Test Limit

The maximum output power shall be less 1 Watt (30dBm).

The conducted output power limit specified in paragraph FCC Part 15.247(b) of this section is based on the use of antennas with directional gains that do not exceed 6 dBi. If transmitting antennas of directional gain greater than 6 dBi are used, the conducted output power from the intentional radiator shall be reduced below the stated values in paragraphs FCC Part 15.247(b)(3) of this section, as appropriate, by the amount in dB that the directional gain of the antenna exceeds 6 dBi.

7.3.2. Test Procedure Used

ANSI C63.10-2013 Section 11.9.1.3

ANSI C63.10-2013 Section 11.9.2.3

7.3.3. Test Setting

Method PKPM1 (Peak Power Measurement)

Peak power measurements were performed only when the EUT was transmitting at its maximum power control level using a broadband power meter with a pulse sensor. The pulse sensor employs a VBW = 50MHz so this method was only used for signals whose DTS bandwidth was less than or equal to 50MHz.

Average Power Measurement

Average power measurements were performed only when the EUT was transmitting at its maximum power control level using a broadband power meter with a pulse sensor. The power meter implemented triggering and gating capabilities which were set up such that power measurements were recorded only during the ON time of the transmitter.

7.3.4. Test Setup

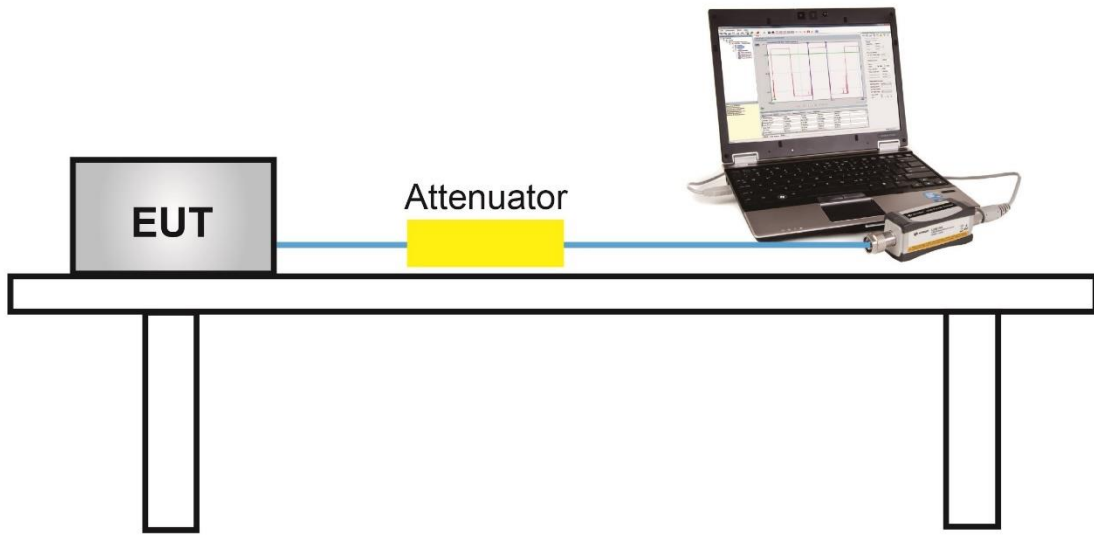

7.3.5. Test Result

Product	ACCESS POINT	Test Engineer	Eric Lin
Test Site	SR2	Test Date	2021/10/31
Model No.	APEX0587		
Filter Configuration	Filter 4#		

Test Result of Peak Output Power

Test Mode	Modulation Mode	Channel No.	Freq. (MHz)	Peak Power (dBm)	Limit (dBm)	Result
802.15.4	O-QPSK	11	2405	9.72	≤ 29.70	Pass
802.15.4	O-QPSK	18	2440	10.05	≤ 29.70	Pass
802.15.4	O-QPSK	26	2480	9.59	≤ 29.70	Pass

Note: Limit (dBm) = 30 dBm – (Max antenna gain 6.3 dBi – 6.0 dBi) = 29.7 dBm.

Test Result of Average Output Power (Reporting Only)

Test Mode	Modulation Mode	Channel No.	Freq. (MHz)	Average Power (dBm)	Limit (dBm)	Result
802.15.4	O-QPSK	11	2405	9.45	≤ 29.70	Pass
802.15.4	O-QPSK	18	2440	9.72	≤ 29.70	Pass
802.15.4	O-QPSK	26	2480	9.30	≤ 29.70	Pass

Note: Limit (dBm) = 30 dBm – (Max antenna gain 6.3 dBi – 6.0 dBi) = 29.7 dBm.

Product	ACCESS POINT	Test Engineer	Eric Lin
Test Site	SR2	Test Date	2021/10/31
Model No.	APEX0587		
Filter Configuration	Filter 5#		

Test Result of Peak Output Power

Test Mode	Modulation Mode	Channel No.	Freq. (MHz)	Peak Power (dBm)	Limit (dBm)	Result
802.15.4	O-QPSK	11	2405	9.55	≤ 29.70	Pass

Note: Limit (dBm) = 30 dBm – (Max antenna gain 6.3 dBi – 6.0 dBi) = 29.7 dBm.

Test Result of Average Output Power (Reporting Only)

Test Mode	Modulation Mode	Channel No.	Freq. (MHz)	AveragePower (dBm)	Limit (dBm)	Result
802.15.4	O-QPSK	11	2405	8.92	≤ 29.70	Pass

Note: Limit (dBm) = 30 dBm – (Max antenna gain 6.3 dBi – 6.0 dBi) = 29.7 dBm.

Product	ACCESS POINT	Test Engineer	Eric Lin
Test Site	SR2	Test Date	2021/10/31
Model No.	APEX0587		
Filter Configuration	Filter 6#		

Test Result of Peak Output Power

Test Mode	Modulation Mode	Channel No.	Freq. (MHz)	Peak Power (dBm)	Limit (dBm)	Result
802.15.4	O-QPSK	26	2480	7.72	≤ 29.70	Pass

Note: Limit (dBm) = 30 dBm – (Max antenna gain 6.3 dBi – 6.0 dBi) = 29.7 dBm.

Test Result of Average Output Power (Reporting Only)

Test Mode	Modulation Mode	Channel No.	Freq. (MHz)	Average Power (dBm)	Limit (dBm)	Result
802.15.4	O-QPSK	26	2480	7.18	≤ 29.70	Pass

Note: Limit (dBm) = 30 dBm – (Max antenna gain 6.3 dBi – 6.0 dBi) = 29.7 dBm.

7.4. Power Spectral Density Measurement

7.4.1. Test Limit

The maximum permissible power spectral density is 8dBm in any 3 kHz band.

The same method of determining the conducted output power shall be used to determine the power spectral density.

7.4.2. Test Procedure Used

ANSI C63.10-2013 Section 11.10.2

7.4.3. Test Setting

1. Analyzer was set to the center frequency of the DTS channel under investigation
2. Span = 1.5 times the DTS channel bandwidth
3. RBW = 3kHz
4. VBW = 10kHz
5. Detector = peak
6. Sweep time = auto couple
7. Trace mode = max hold
8. Trace was allowed to stabilize

7.4.4. Test Setup

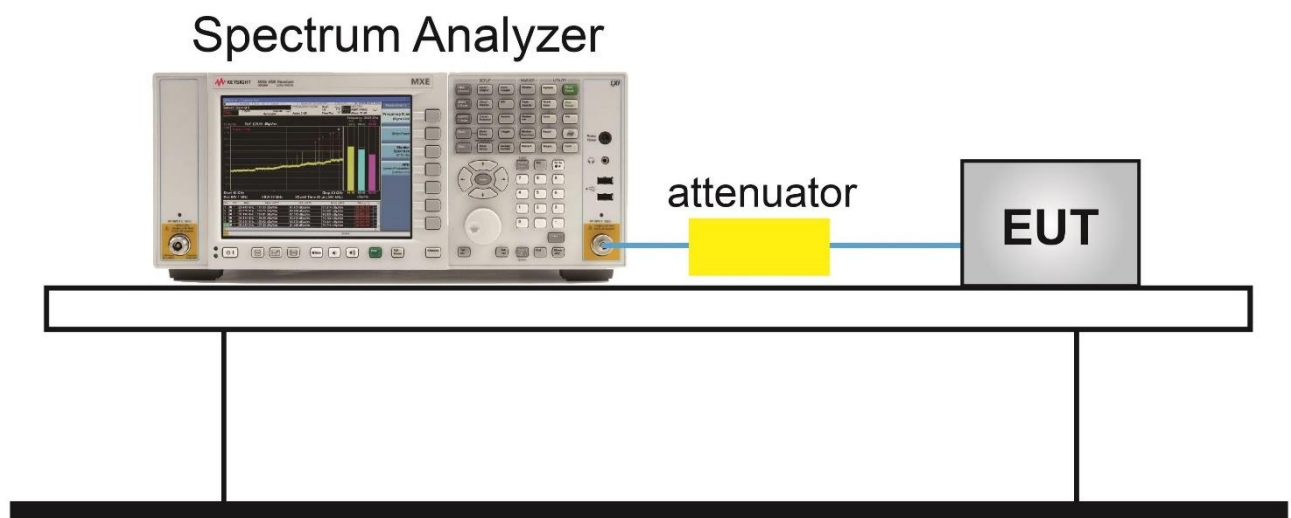

7.4.5. Test Result

Product	ACCESS POINT	Test Engineer	Eric Lin
Test Site	SR2	Test Date	2021/10/31
Model No.	APEX0587		
Filter Configuration	Filter 4#		

Test Mode	Modulation Mode	Channel No.	Frequency (MHz)	PK PSD (dBm / 3kHz)	Limit (dBm / 3kHz)	Result
802.15.4	O-QPSK	11	2405	-3.524	≤ 7.70	Pass
802.15.4	O-QPSK	18	2440	-1.487	≤ 7.70	Pass
802.15.4	O-QPSK	26	2480	-0.463	≤ 7.70	Pass

Note: Limit (dBm/3kHz) = 8 dBm/3kHz – (Max antenna gain 6.3 dBi – 6.0 dBi) = 7.7 dBm/3kHz.

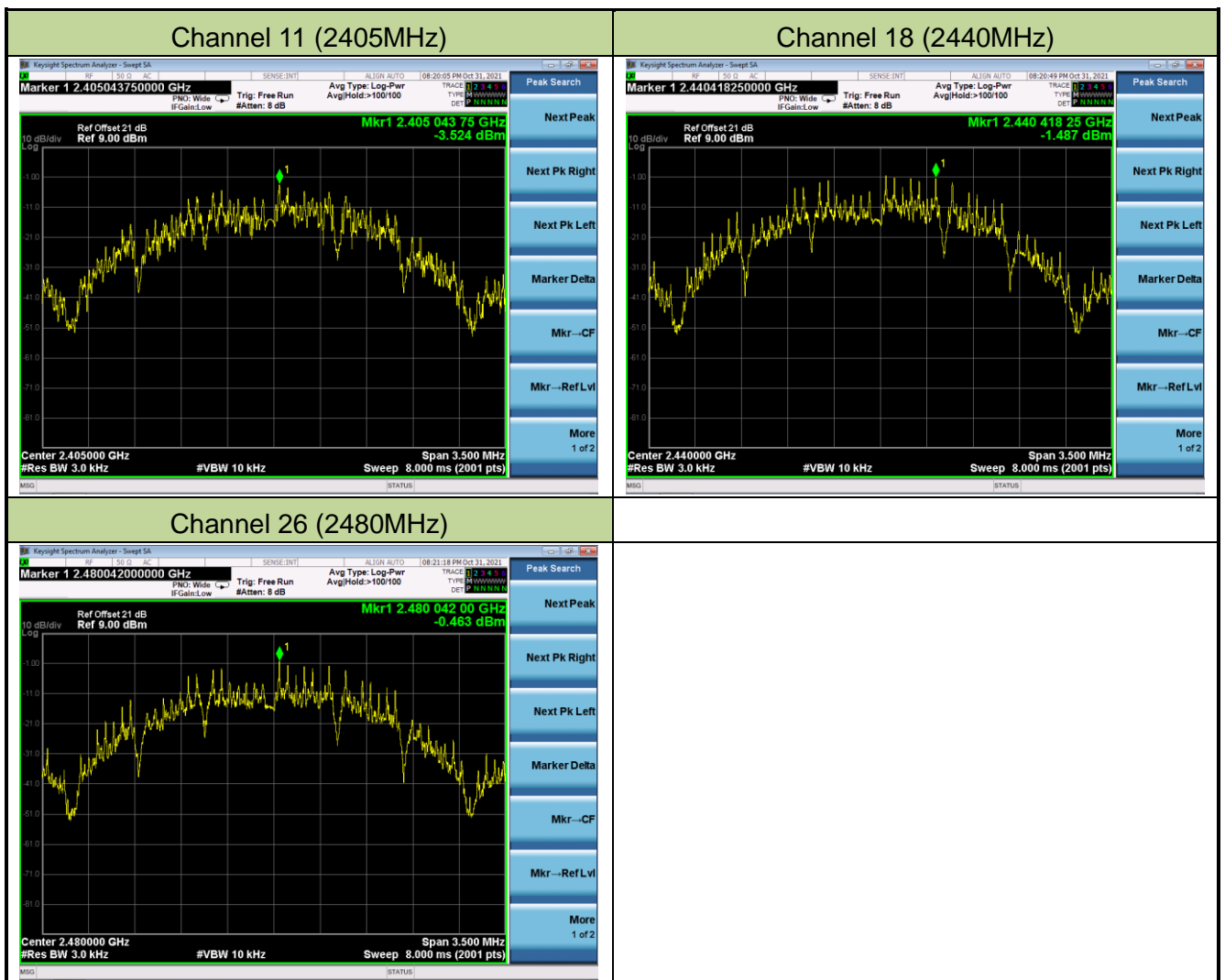

7.5. Conducted Band Edge and Out-of-Band Emissions

7.5.1. Test Limit

The limit for out-of-band spurious emissions at the band edge is 20dB below the fundamental emission level, as determined from the in-band power measurement of the DTS channel performed in a 100kHz bandwidth per the PSD procedure.

7.5.2. Test Procedure Used

ANSI C63.10-2013 Section 11.11

7.5.3. Test Setting

Reference level measurement

1. Set instrument center frequency to DTS channel center frequency
2. Set the span to ≥ 1.5 times the DTS bandwidth
3. Set the RBW = 100 kHz
4. Set the VBW $\geq 3 \times$ RBW
5. Detector = peak
6. Sweep time = auto couple
7. Trace mode = max hold
8. Allow trace to fully stabilize

Emission level measurement

1. Start frequency was set to 30MHz and stop frequency was set to 25GHz (separated into two plots per channel)
2. RBW = 100kHz
3. VBW = 300kHz
4. Detector = Peak
5. Trace mode = max hold
6. Sweep time = auto couple
7. The trace was allowed to stabilize

7.5.4. Test Setup

Spectrum Analyzer

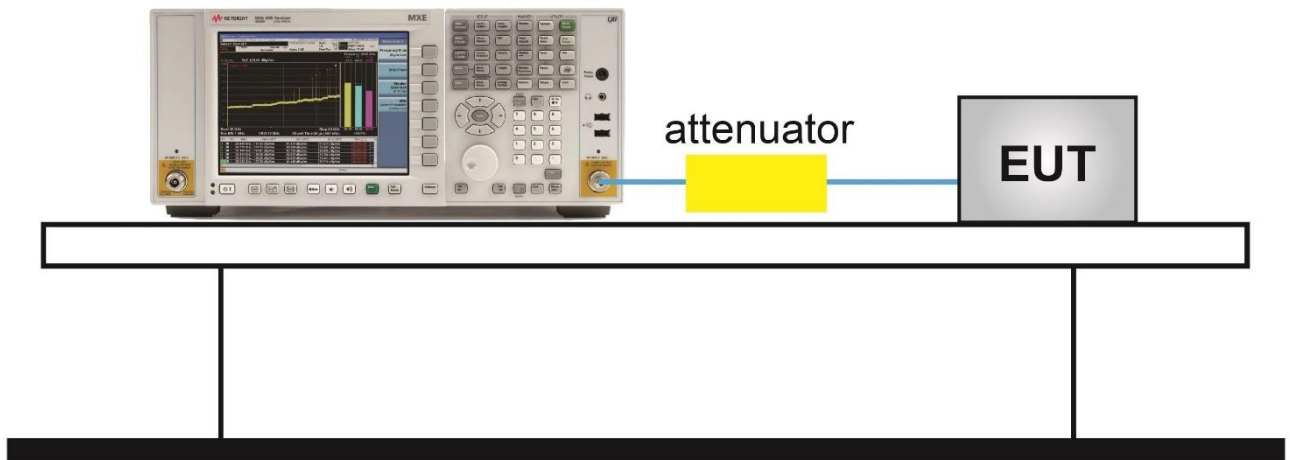

7.5.5. Test Result

Product	ACCESS POINT	Test Engineer	Eric Lin
Test Site	SR2	Test Date	2021/10/31
Model No.	APEX0587		
Filter Configuration	Filter 4#		

Test Mode	Data Rate / MCS	Channel No.	Frequency (MHz)	Limit (dBc)	Result
802.15.4	O-QPSK	11	2405	> 20	Pass
802.15.4	O-QPSK	18	2440	> 20	Pass
802.15.4	O-QPSK	26	2480	> 20	Pass

Product	ACCESS POINT	Test Engineer	Eric Lin
Test Site	SR2	Test Date	2021/10/31
Model No.	APEX0587		
Filter Configuration	Filter 5#		

Test Mode	Data Rate / MCS	Channel No.	Frequency (MHz)	Limit (dBc)	Result
802.15.4	O-QPSK	11	2405	> 20	Pass

Product	ACCESS POINT	Test Engineer	Eric Lin
Test Site	SR2	Test Date	2021/10/31
Model No.	APEX0587		
Filter Configuration	Filter 6#		

Test Mode	Data Rate / MCS	Channel No.	Frequency (MHz)	Limit (dBc)	Result
802.15.4	O-QPSK	26	2480	> 20	Pass

Filter 4#

802.15.4 Out-of-Band Emissions

Channel 11 (2405MHz)

100kHz PSD Reference Level



Low Band Edge

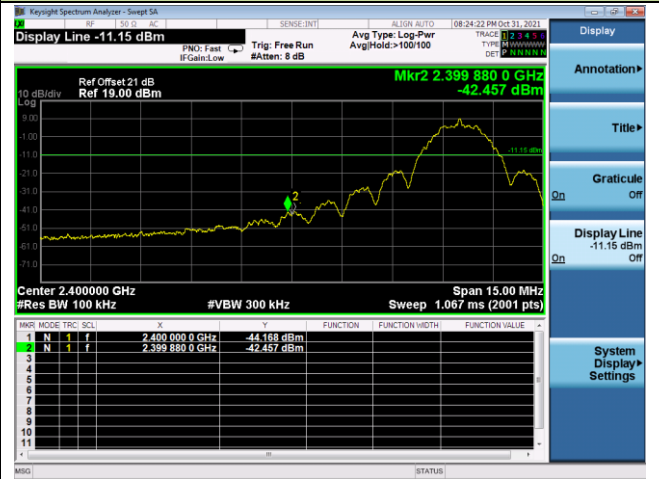

Spurious Emission

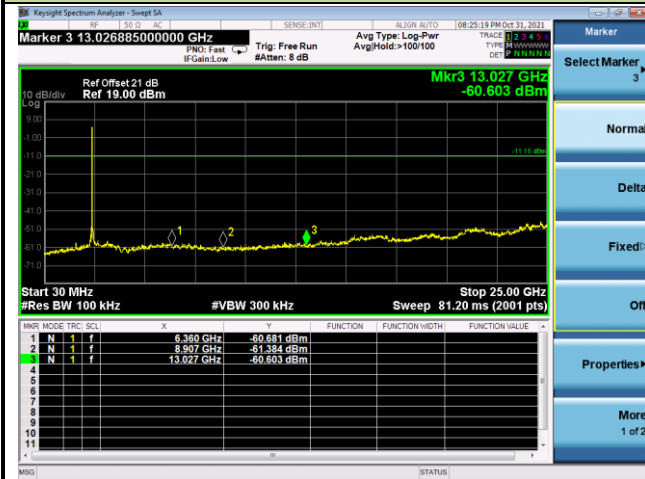

Channel 18 (2440MHz)

100kHz PSD Reference Level

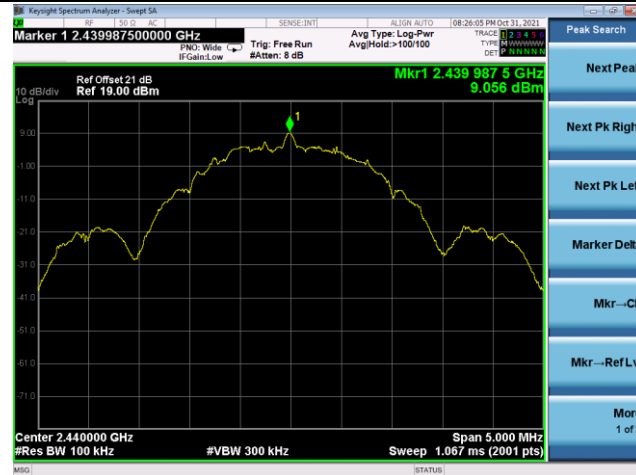

Spurious Emission

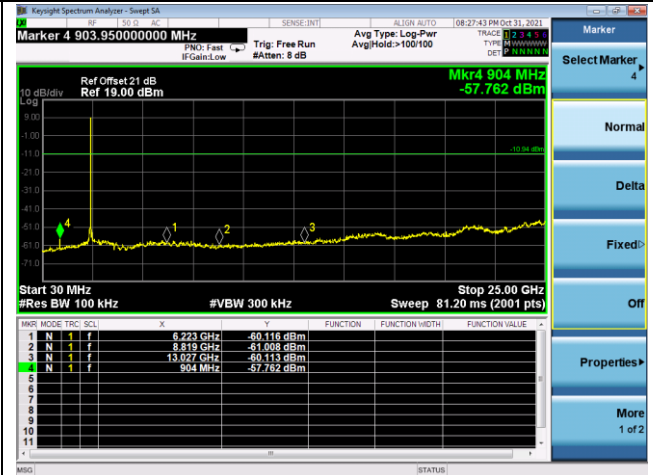

Channel 26 (2480MHz)

100kHz PSD Reference Level



High Band Edge



Spurious Emission

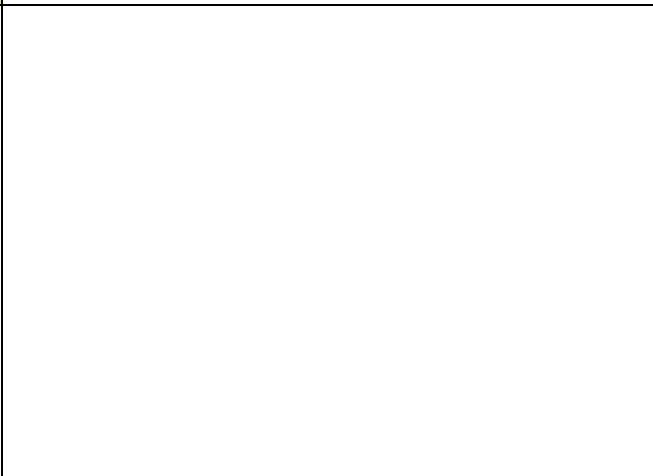
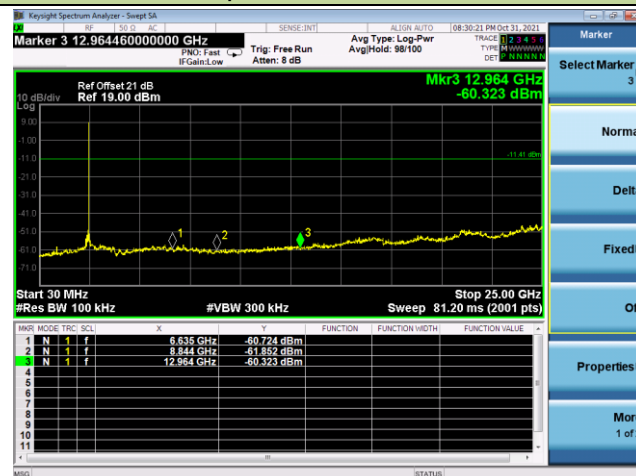

Filter 5#

802.15.4 Out-of-Band Emissions

Channel 00 (2405MHz)

100kHz PSD reference Level



Low Band Edge



Spurious Emission

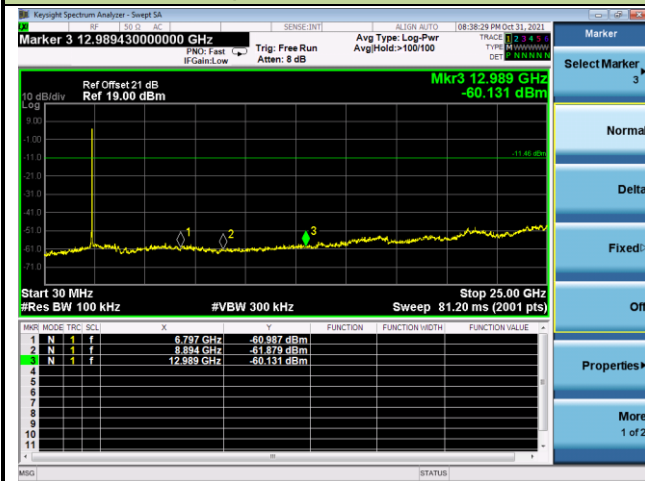

Filter 6#



7.6. Radiated Spurious Emission Measurement

7.6.1. Test Limit

All out of band emissions appearing in a restricted band as specified in Section 15.205 of the Title 47 CFR must not exceed the limits shown in Table per Section 15.209.

FCC Part 15 Subpart C Paragraph 15.209		
Frequency [MHz]	Field Strength [uV/m]	Measured Distance [Meters]
0.009 - 0.490	2400/F (kHz)	300
0.490 - 1.705	24000/F (kHz)	30
1.705 - 30	30	30
30 - 88	100	3
88 - 216	150	3
216 - 960	200	3
Above 960	500	3

7.6.2. Test Procedure Used

ANSI C63.10-2013 Section 6.3 (General Requirements)

ANSI C63.10-2013 Section 6.4 (Standard test method below 30MHz)

ANSI C63.10-2013 Section 6.5 (Standard test method above 30MHz to 1GHz)

ANSI C63.10-2013 Section 6.6 (Standard test method above 1GHz)

ANSI C63.10-2013 Section 11.11 & 11.12

7.6.3. Test Setting

Table 1 - RBW as a function of frequency

Frequency	RBW
9 ~ 150 kHz	200 ~ 300 Hz
0.15 ~ 30 MHz	9 ~ 10 kHz
30 ~ 1000 MHz	100 ~ 120 kHz

Quasi-Peak Measurements below 1GHz

1. Analyzer center frequency was set to the frequency of the radiated spurious emission of interest
2. Span was set greater than 1MHz
3. RBW = as specified in Table 1
4. Detector = CISPR quasi-peak
5. Sweep time = auto couple
6. Trace was allowed to stabilize

Peak Measurements above 1GHz

1. Analyzer center frequency was set to the frequency of the radiated spurious emission of interest
2. RBW = 1MHz
3. VBW = 3MHz
4. Detector = peak
5. Sweep time = auto couple
6. Trace mode = max hold
7. Trace was allowed to stabilize

Average Measurements above 1GHz

1. Analyzer center frequency was set to the frequency of the radiated spurious emission of interest
2. RBW = 1MHz
3. VBW = $1 / T$, (VBW = 300Hz)
4. Average Type = Voltage
5. Detector = Peak
6. Sweep time = auto
7. Trace mode = max hold
8. Trace was allowed to stabilize

7.6.4. Test Setup

Below 1GHz Test Setup:

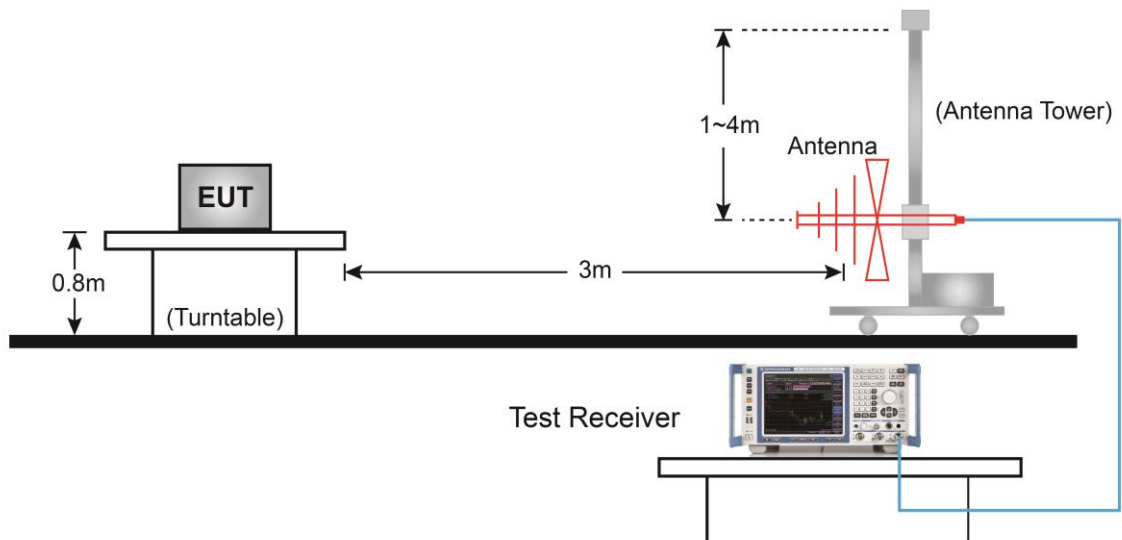

Above 1GHz Test Setup:

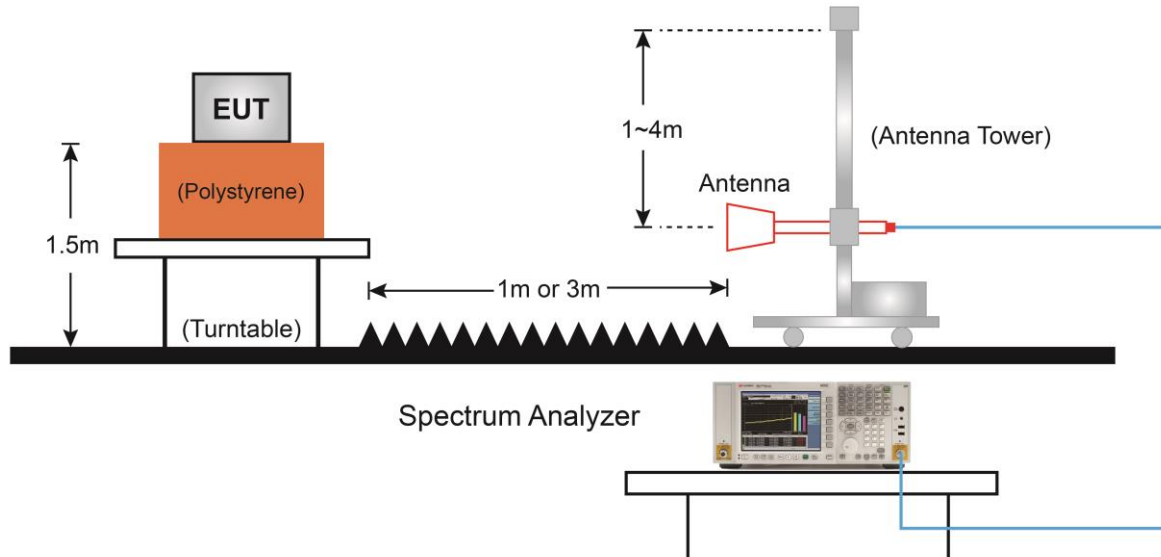

7.6.5. Test Result

APEX0585 Filter 4#:

EUT	ASSESS POINT	Date of Test	2021-11-05
Factor	BBHA 9120D (1GHz~18GHz)_2021	Temp. / Humidity	23.0°C/50.5%
Polarity	Horizontal	Site / Test Engineer	AC1 / Jay
Test Mode	Transmit by Zigbee at Channel 2405MHz	Test Voltage	By PoE

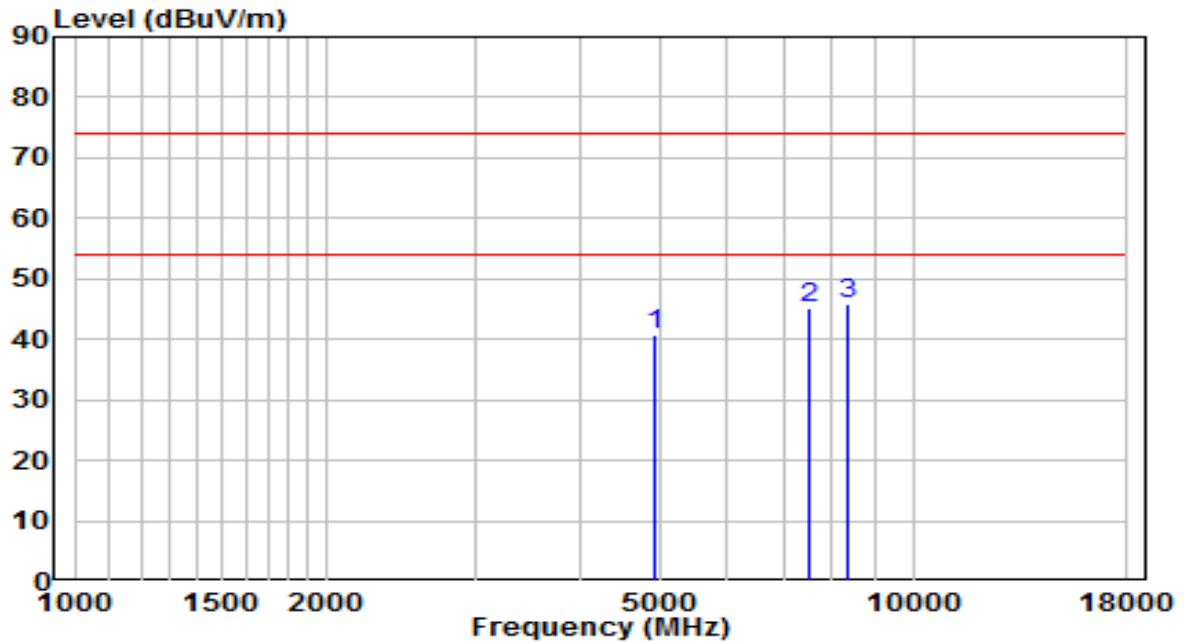

No	Frequency (MHz)	Reading (dBUV)	C.F (dB/m)	Measurement (dBUV/m)	Margin (dB)	Limit (dBUV/m)	Remark (QP/PK/AV)
1	4901.500	37.01	3.77	40.78	-33.22	74.00	Peak
2	7511.000	32.31	13.02	45.33	-28.67	74.00	Peak
3	* 8327.000	32.28	13.58	45.86	-28.14	74.00	Peak

Note:

- "*" means this data is the worst emission level.
- C.F (Correction Factor) = Antenna Factor (dB/m)+ Cable Loss (dB)– Preamplifier(dB).
- Measurement(dBUV/m) = Reading(dBUV) + C.F (Correction Factor).
- The emission levels of other frequencies are very lower than the limit and not show in test report.

EUT	ASSESS POINT	Date of Test	2021-11-05
Factor	BBHA 9120D (1GHz~18GHz)_2021	Temp. / Humidity	23.0°C/50.5%
Polarity	Vertical	Site / Test Engineer	AC1 / Jay
Test Mode	Transmit by Zigbee at Channel 2405MHz	Test Voltage	By PoE

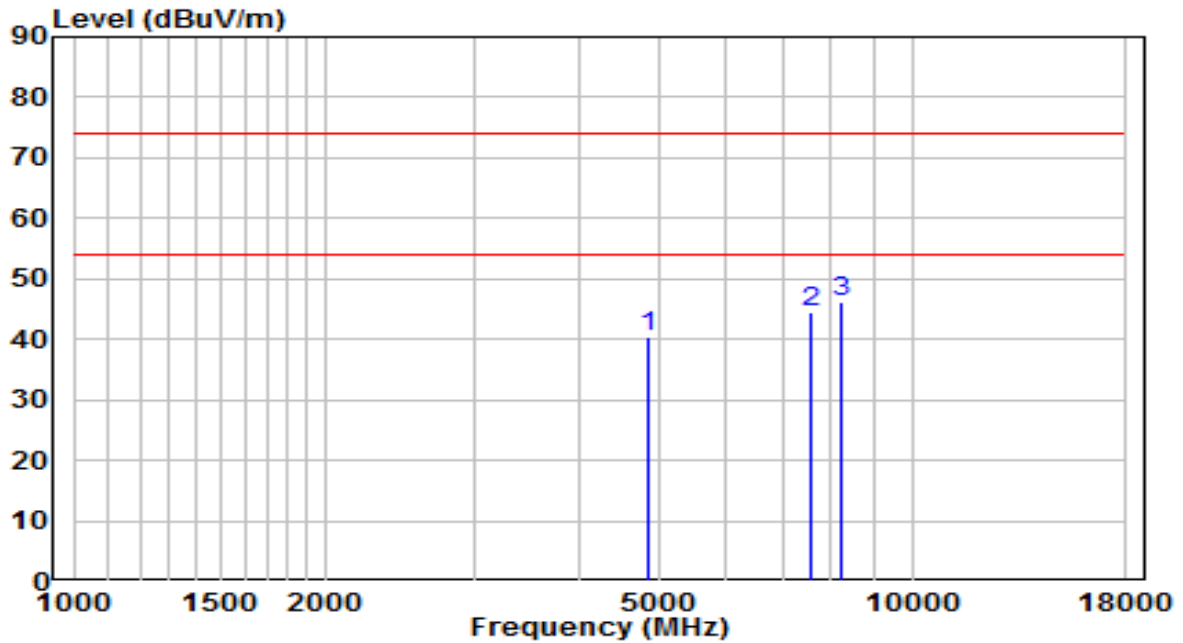

No	Frequency (MHz)	Reading (dBuV)	C.F (dB/m)	Measurement (dBuV/m)	Margin (dB)	Limit (dBuV/m)	Remark (QP/PK/AV)
1	4833.500	36.93	3.65	40.58	-33.42	74.00	Peak
2	7587.500	31.26	13.09	44.35	-29.65	74.00	Peak
3	* 8216.500	32.78	13.53	46.31	-27.69	74.00	Peak

Note:

1. " *", means this data is the worst emission level.
2. C.F (Correction Factor) = Antenna Factor (dB/m)+ Cable Loss (dB)– Preamplifier(dB).
3. Measurement(dBuV/m) = Reading(dBuV) + C.F (Correction Factor).
- 4.The emission levels of other frequencies are very lower than the limit and not show in test report.

EUT	ASSESS POINT	Date of Test	2021-11-05
Factor	BBHA 9120D (1GHz~18GHz)_2021	Temp. / Humidity	23.0°C/50.5%
Polarity	Horizontal	Site / Test Engineer	AC1 / Jay
Test Mode	Transmit by Zigbee at Channel 2440MHz	Test Voltage	By PoE

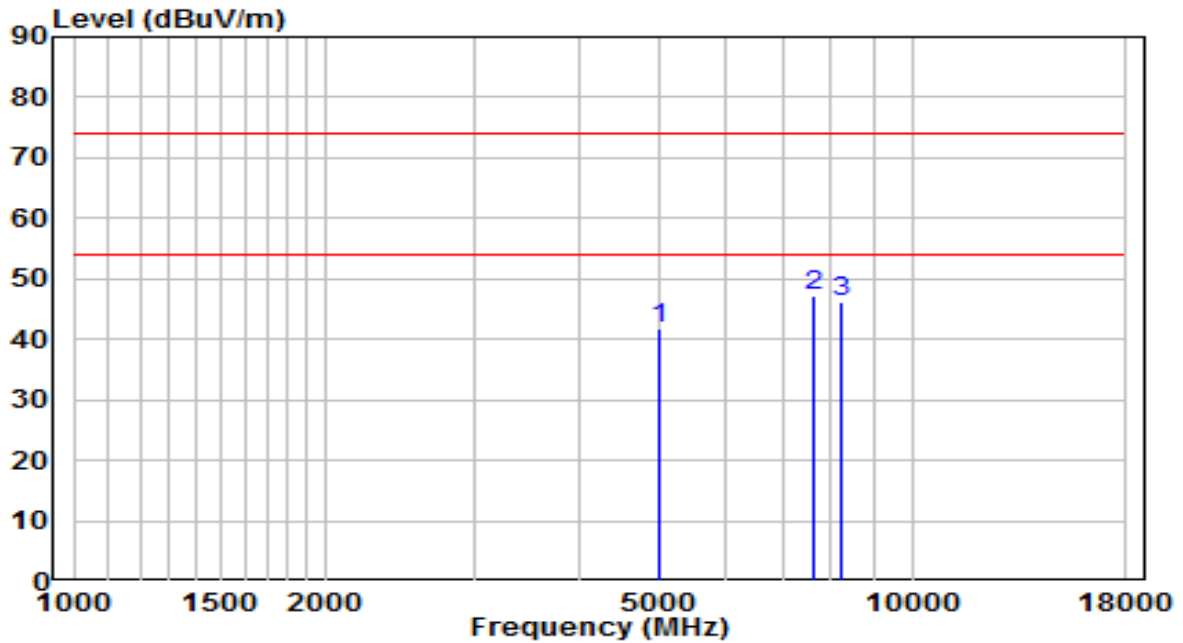

No	Frequency (MHz)	Reading (dBuV)	C.F (dB/m)	Measurement (dBuV/m)	Margin (dB)	Limit (dBuV/m)	Remark (QP/PK/AV)
1	4986.500	37.86	3.93	41.78	-32.22	74.00	Peak
2	* 7621.500	34.00	13.12	47.12	-26.88	74.00	Peak
3	8233.500	32.65	13.54	46.19	-27.81	74.00	Peak

Note:

1. " *", means this data is the worst emission level.
2. C.F (Correction Factor) = Antenna Factor (dB/m)+ Cable Loss (dB)– Preamplifier(dB).
3. Measurement(dBuV/m) = Reading(dBuV) + C.F (Correction Factor).
- 4.The emission levels of other frequencies are very lower than the limit and not show in test report.

EUT	ASSESS POINT	Date of Test	2021-11-05
Factor	BBHA 9120D (1GHz~18GHz)_2021	Temp. / Humidity	23.0°C/50.5%
Polarity	Vertical	Site / Test Engineer	AC1 / Jay
Test Mode	Transmit by Zigbee at Channel 2440MHz	Test Voltage	By PoE

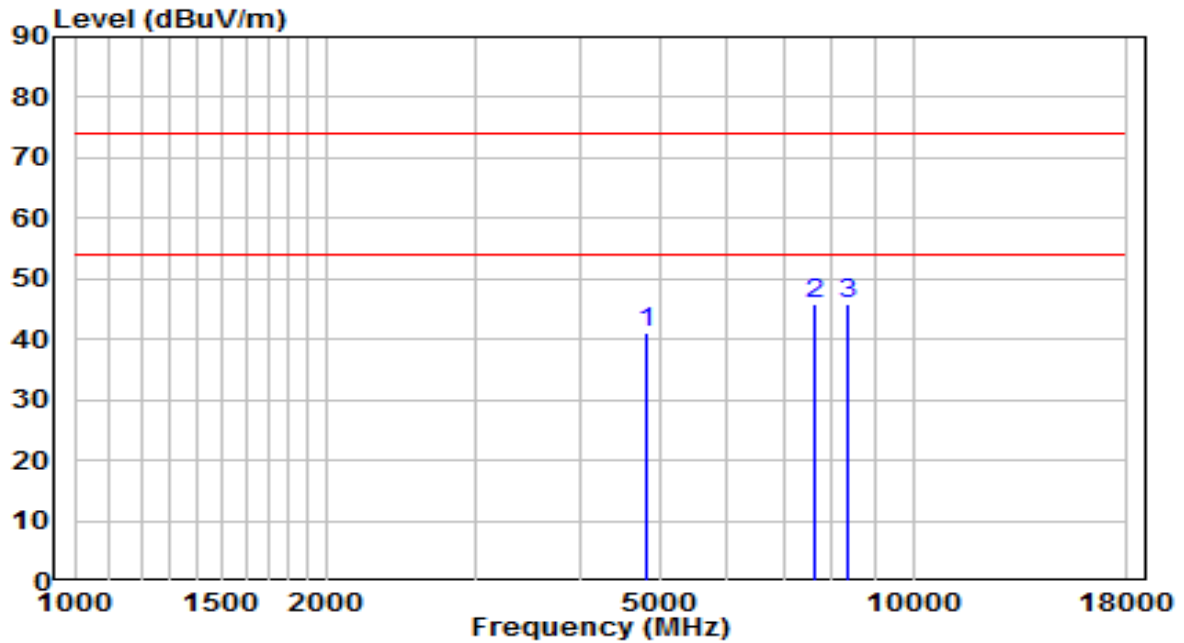

No	Frequency (MHz)	Reading (dBuV)	C.F (dB/m)	Measurement (dBuV/m)	Margin (dB)	Limit (dBuV/m)	Remark (QP/PK/AV)
1	4808.000	37.64	3.60	41.24	-32.76	74.00	Peak
2	7630.000	32.67	13.12	45.79	-28.21	74.00	Peak
3	* 8369.500	32.25	13.60	45.85	-28.15	74.00	Peak

Note:

1. " *", means this data is the worst emission level.
2. C.F (Correction Factor) = Antenna Factor (dB/m)+ Cable Loss (dB)– Preamplifier(dB).
3. Measurement(dBuV/m) = Reading(dBuV) + C.F (Correction Factor).
- 4.The emission levels of other frequencies are very lower than the limit and not show in test report.

EUT	ASSESS POINT	Date of Test	2021-11-05
Factor	BBHA 9120D (1GHz~18GHz)_2021	Temp. / Humidity	23.0°C/50.5%
Polarity	Horizontal	Site / Test Engineer	AC1 / Jay
Test Mode	Transmit by Zigbee at Channel 2480MHz	Test Voltage	By PoE

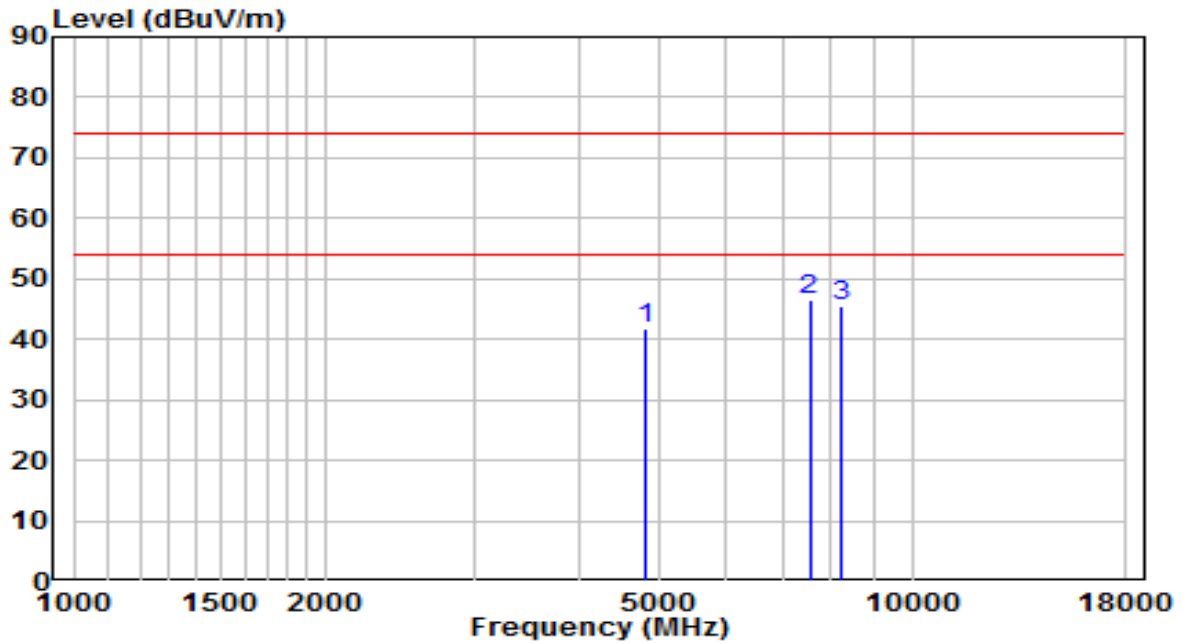

No	Frequency (MHz)	Reading (dBuV)	C.F (dB/m)	Measurement (dBuV/m)	Margin (dB)	Limit (dBuV/m)	Remark (QP/PK/AV)
1	4816.500	38.06	3.62	41.68	-32.32	74.00	Peak
2	* 7545.000	33.40	13.05	46.45	-27.55	74.00	Peak
3	8259.000	31.89	13.55	45.44	-28.56	74.00	Peak

Note:

1. " *", means this data is the worst emission level.
2. C.F (Correction Factor) = Antenna Factor (dB/m)+ Cable Loss (dB)– Preamplifier(dB).
3. Measurement(dBuV/m) = Reading(dBuV) + C.F (Correction Factor).
- 4.The emission levels of other frequencies are very lower than the limit and not show in test report.

EUT	ASSESS POINT	Date of Test	2021-11-05
Factor	BBHA 9120D (1GHz~18GHz)_2021	Temp. / Humidity	23.0°C/50.5%
Polarity	Vertical	Site / Test Engineer	AC1 / Jay
Test Mode	Transmit by Zigbee at Channel 2480MHz	Test Voltage	By PoE

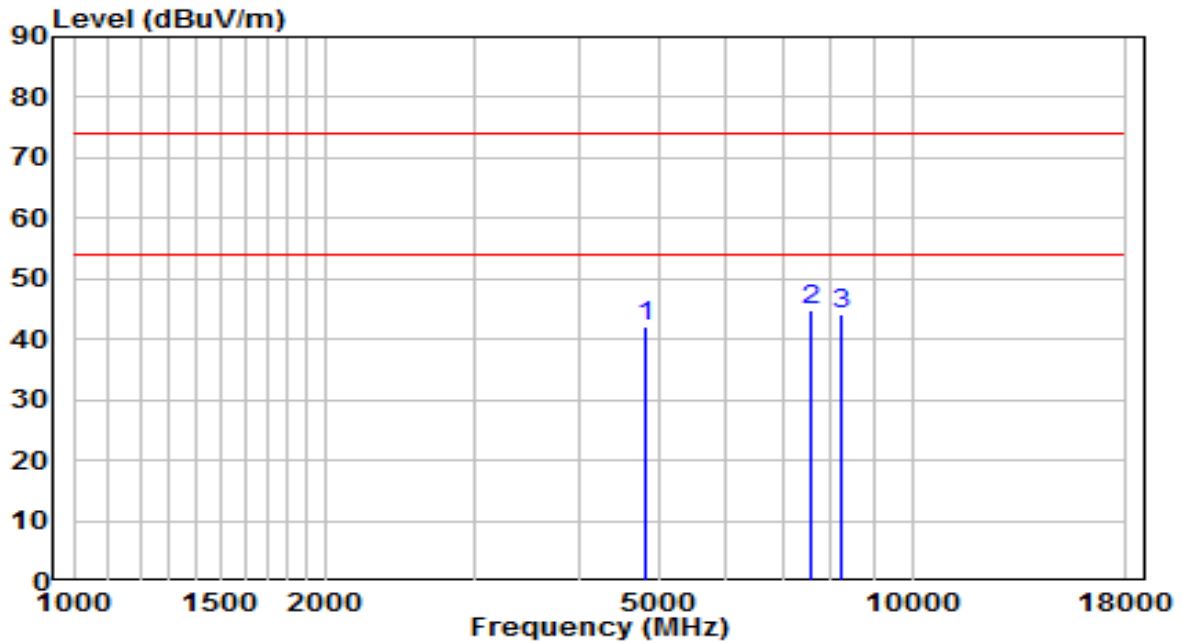

No	Frequency (MHz)	Reading (dBuV)	C.F (dB/m)	Measurement (dBuV/m)	Margin (dB)	Limit (dBuV/m)	Remark (QP/PK/AV)
1	4799.500	38.37	3.59	41.96	-32.04	74.00	Peak
2	* 7553.500	31.84	13.06	44.90	-29.10	74.00	Peak
3	8259.000	30.57	13.55	44.12	-29.88	74.00	Peak

Note:

1. " *", means this data is the worst emission level.
2. C.F (Correction Factor) = Antenna Factor (dB/m)+ Cable Loss (dB)– Preamplifier(dB).
3. Measurement(dBuV/m) = Reading(dBuV) + C.F (Correction Factor).
- 4.The emission levels of other frequencies are very lower than the limit and not show in test report.

APEX0585 Filter 5#:

EUT	Access point	Date of Test	2021-11-05
Factor	BBHA 9120D (1GHz~18GHz)_2021	Temp. / Humidity	23.0°C/50.5%
Polarity	Horizontal	Site / Test Engineer	AC1 / Jay
Test Mode	Transmit by Zigbee at Channel 2405MHz	Test Voltage	By PoE

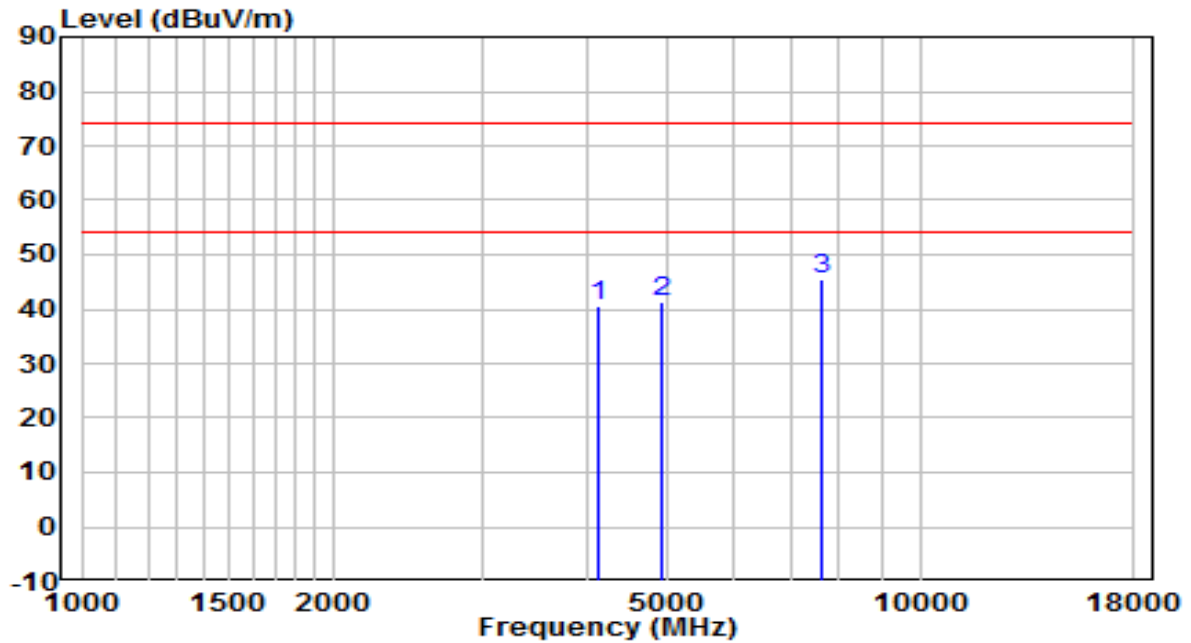

No	Frequency (MHz)	Reading (dBuV)	C.F (dB/m)	Measurement (dBuV/m)	Margin (dB)	Limit (dBuV/m)	Remark (QP/PK/AV)
1	4119.500	38.88	1.63	40.51	-33.49	74.00	Peak
2	4910.000	37.38	3.79	41.17	-32.83	74.00	Peak
3	* 7621.500	32.43	13.12	45.55	-28.45	74.00	Peak

Note:

1. " *", means this data is the worst emission level.
2. C.F (Correction Factor) = Antenna Factor (dB/m)+ Cable Loss (dB)– Preamplifier(dB).
3. Measurement(dBuV/m) = Reading(dBuV) + C.F (Correction Factor).
- 4.The emission levels of other frequencies are very lower than the limit and not show in test report.

EUT	Access point	Date of Test	2021-11-05
Factor	BBHA 9120D (1GHz~18GHz)_2021	Temp. / Humidity	23.0°C/50.5%
Polarity	Vertical	Site / Test Engineer	AC1 / Jay
Test Mode	Transmit by Zigbee at Channel 2405MHz	Test Voltage	By PoE

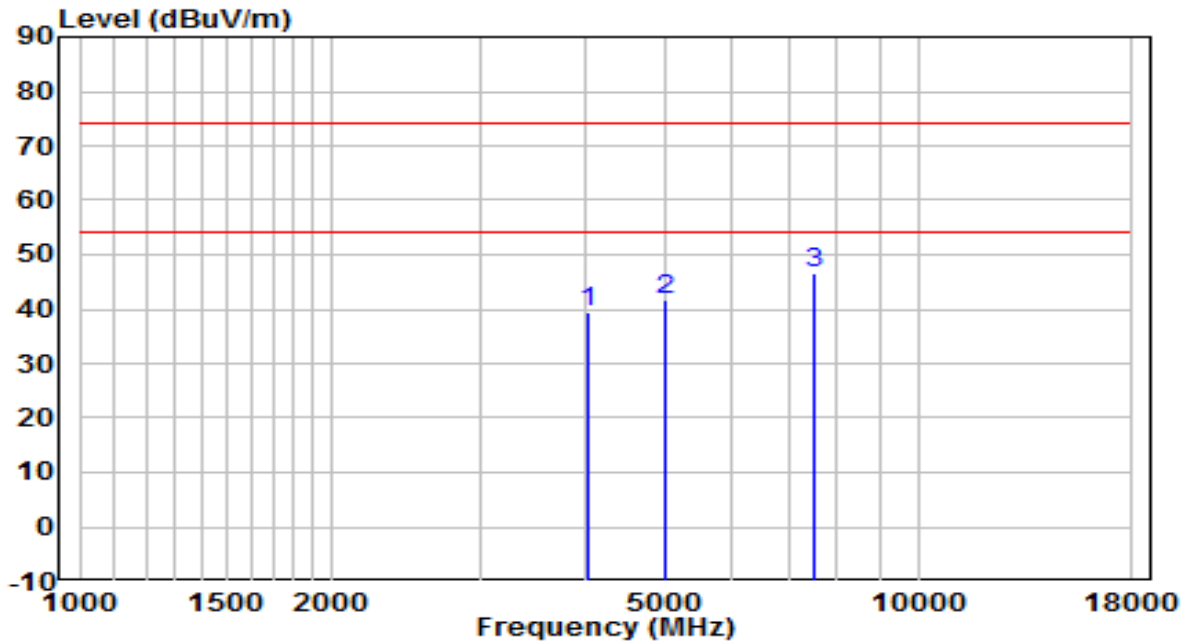

No	Frequency (MHz)	Reading (dBuV)	C.F (dB/m)	Measurement (dBuV/m)	Margin (dB)	Limit (dBuV/m)	Remark (QP/PK/AV)
1	4043.000	38.23	1.34	39.58	-34.42	74.00	Peak
2	4978.000	37.66	3.91	41.57	-32.43	74.00	Peak
3	* 7536.500	33.64	13.05	46.68	-27.32	74.00	Peak

Note:

1. " *", means this data is the worst emission level.
2. C.F (Correction Factor) = Antenna Factor (dB/m)+ Cable Loss (dB)– Preamplifier(dB).
3. Measurement(dBuV/m) = Reading(dBuV) + C.F (Correction Factor).
- 4.The emission levels of other frequencies are very lower than the limit and not show in test report.

APEX0585 Filter 6#:

EUT	Access point	Date of Test	2021-11-05
Factor	BBHA 9120D (1GHz~18GHz)_2021	Temp. / Humidity	23.0°C/50.5%
Polarity	Horizontal	Site / Test Engineer	AC1 / Jay
Test Mode	Transmit by Zigbee at Channel 2480MHz	Test Voltage	By PoE

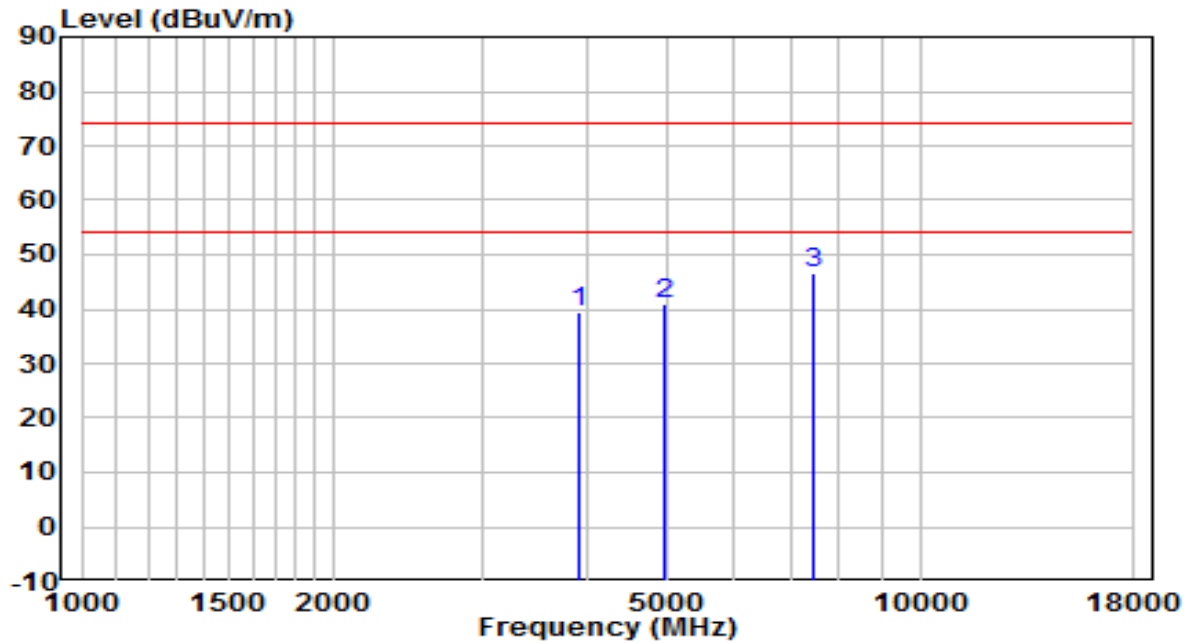

No	Frequency (MHz)	Reading (dBuV)	C.F (dB/m)	Measurement (dBuV/m)	Margin (dB)	Limit (dBuV/m)	Remark (QP/PK/AV)
1	3932.500	38.58	0.97	39.56	-34.44	74.00	Peak
2	4969.500	37.08	3.90	40.97	-33.03	74.00	Peak
3	* 7468.500	33.84	12.88	46.71	-27.29	74.00	Peak

Note:

1. " *", means this data is the worst emission level.
2. C.F (Correction Factor) = Antenna Factor (dB/m)+ Cable Loss (dB)– Preamplifier(dB).
3. Measurement(dBuV/m) = Reading(dBuV) + C.F (Correction Factor).
- 4.The emission levels of other frequencies are very lower than the limit and not show in test report.

EUT	Access point	Date of Test	2021-11-05
Factor	BBHA 9120D (1GHz~18GHz)_2021	Temp. / Humidity	23.0°C/50.5%
Polarity	Vertical	Site / Test Engineer	AC1 / Jay
Test Mode	Transmit by Zigbee at Channel 2480MHz	Test Voltage	By PoE

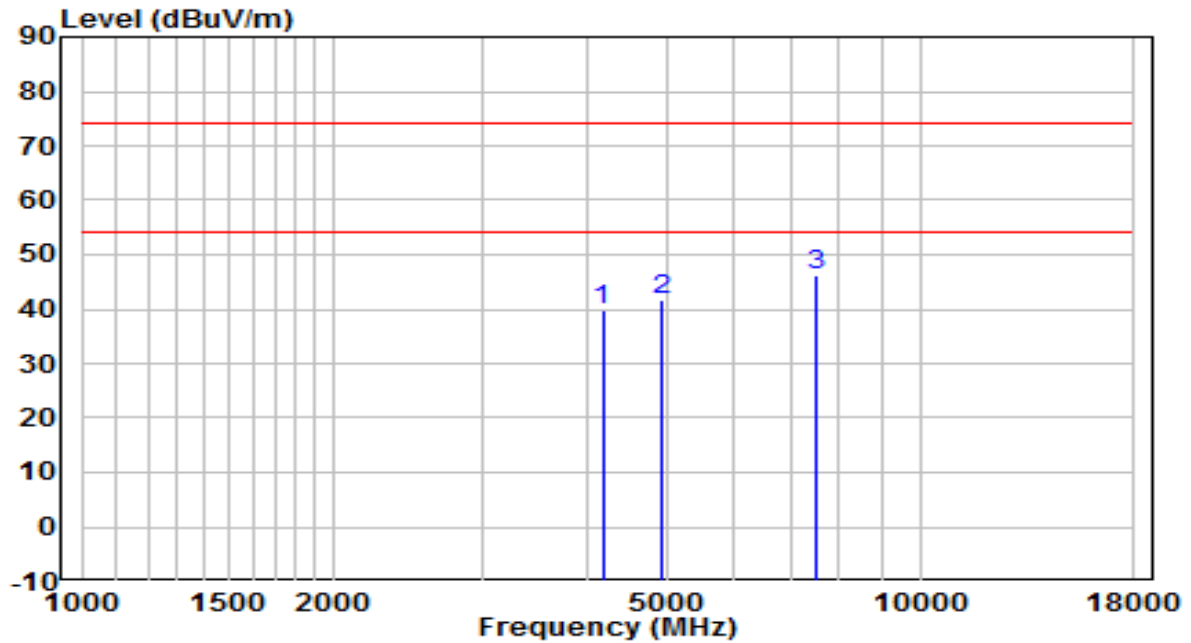

No	Frequency (MHz)	Reading (dBuV)	C.F (dB/m)	Measurement (dBuV/m)	Margin (dB)	Limit (dBuV/m)	Remark (QP/PK/AV)
1	4179.000	38.11	1.85	39.96	-34.04	74.00	Peak
2	4935.500	37.70	3.83	41.54	-32.46	74.00	Peak
3	* 7494.000	33.27	12.99	46.26	-27.74	74.00	Peak

Note:

1. " *", means this data is the worst emission level.
2. C.F (Correction Factor) = Antenna Factor (dB/m)+ Cable Loss (dB)– Preamplifier(dB).
3. Measurement(dBuV/m) = Reading(dBuV) + C.F (Correction Factor).
- 4.The emission levels of other frequencies are very lower than the limit and not show in test report.

APEX0587 Filter 4#:

EUT	ASSESS POINT	Date of Test	2021-11-07
Factor	BBHA 9120D (1GHz~18GHz)_2021	Temp. / Humidity	25.8°C/44.6%
Polarity	Horizontal	Site / Test Engineer	AC1 / Jay
Test Mode	Transmit by Zigbee at Channel 2405MHz	Test Voltage	By PoE

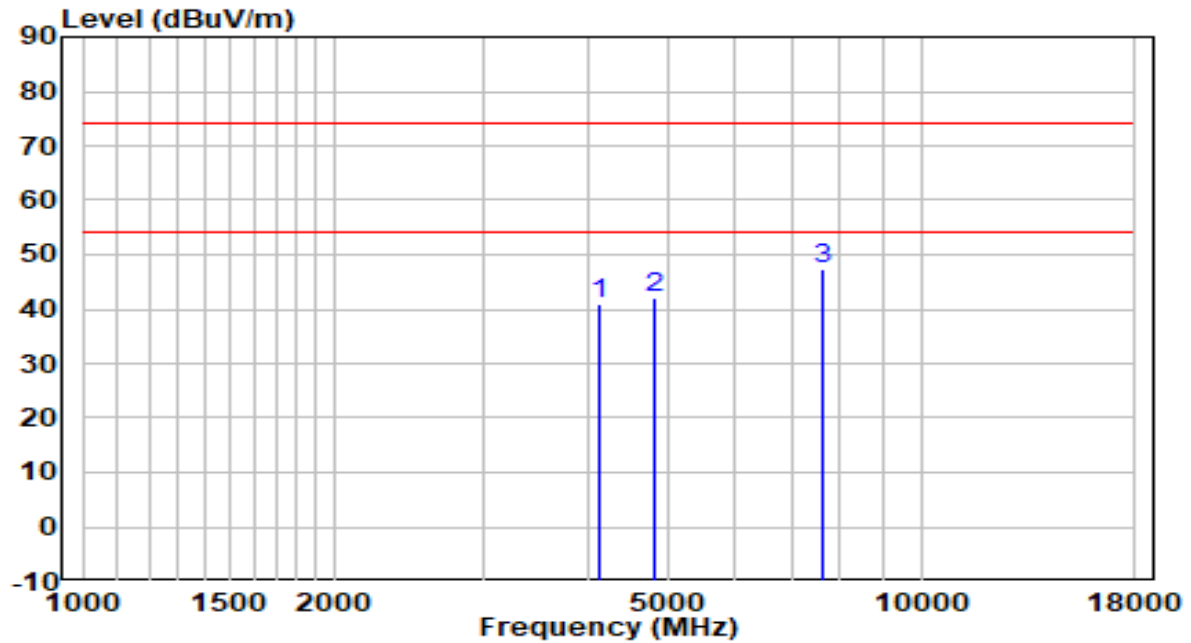

No	Frequency (MHz)	Reading (dBuV)	C.F (dB)	Measurement (dBuV/m)	Margin (dB)	Limit (dBuV/m)	Remark (QP/PK/AV)
1	4119.500	39.43	1.63	41.05	-32.95	74.00	Peak
2	4825.000	38.58	3.64	42.22	-31.78	74.00	Peak
3	* 7638.500	34.29	13.13	47.42	-26.58	74.00	Peak

Note:

1. " *", means this data is the worst emission level.
2. C.F (Correction Factor) = Antenna Factor (dB)+ Cable Loss (dB)– Preamplifier(dB).
3. Measurement(dBuV/m) = Reading(dBuV) + C.F (Correction Factor).
- 4.The emission levels of other frequencies are very lower than the limit and not show in test report.

EUT	ASSESS POINT	Date of Test	2021-11-07
Factor	BBHA 9120D (1GHz~18GHz)_2021	Temp. / Humidity	25.8°C/44.6%
Polarity	Vertical	Site / Test Engineer	AC1 / Jay
Test Mode	Transmit by Zigbee at Channel 2405MHz	Test Voltage	By PoE

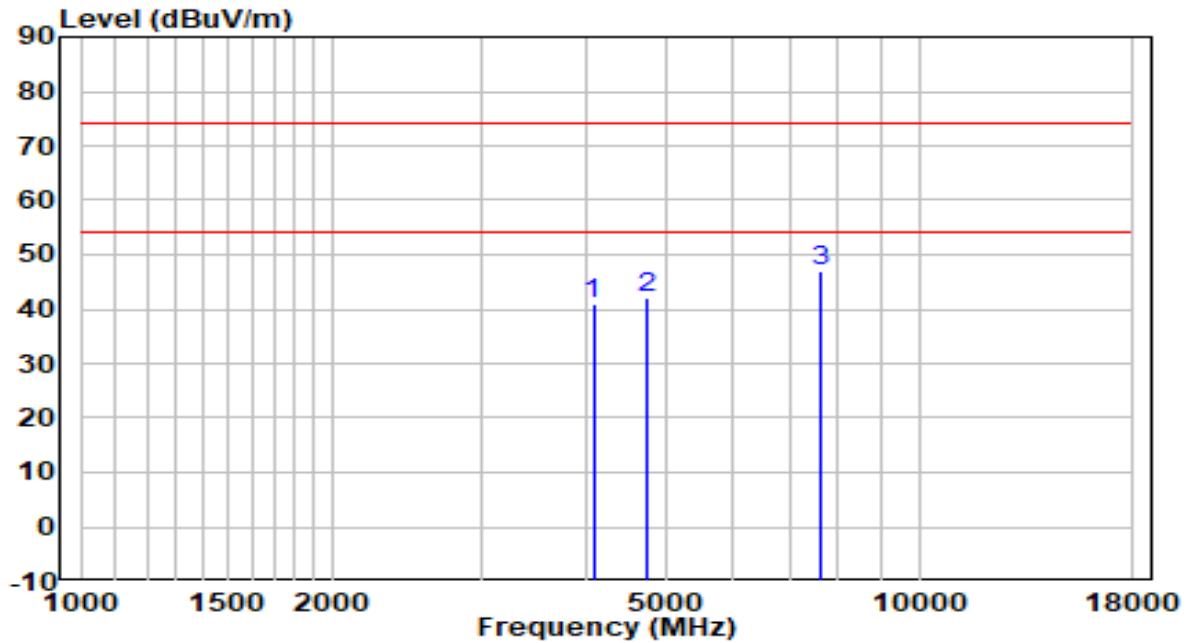

No	Frequency (MHz)	Reading (dBuV)	C.F (dB)	Measurement (dBuV/m)	Margin (dB)	Limit (dBuV/m)	Remark (QP/PK/AV)
1	4085.500	39.42	1.50	40.92	-33.08	74.00	Peak
2	4740.000	38.63	3.48	42.11	-31.89	74.00	Peak
3	* 7638.500	33.78	13.13	46.91	-27.09	74.00	Peak

Note:

1. " *", means this data is the worst emission level.
2. C.F (Correction Factor) = Antenna Factor (dB)+ Cable Loss (dB)– Preamplifier(dB).
3. Measurement(dBuV/m) = Reading(dBuV) + C.F (Correction Factor).
- 4.The emission levels of other frequencies are very lower than the limit and not show in test report.

EUT	ASSESS POINT	Date of Test	2021-11-07
Factor	BBHA 9120D (1GHz~18GHz)_2021	Temp. / Humidity	25.8°C/44.6%
Polarity	Horizontal	Site / Test Engineer	AC1 / Jay
Test Mode	Transmit by Zigbee at Channel 2440MHz	Test Voltage	By PoE

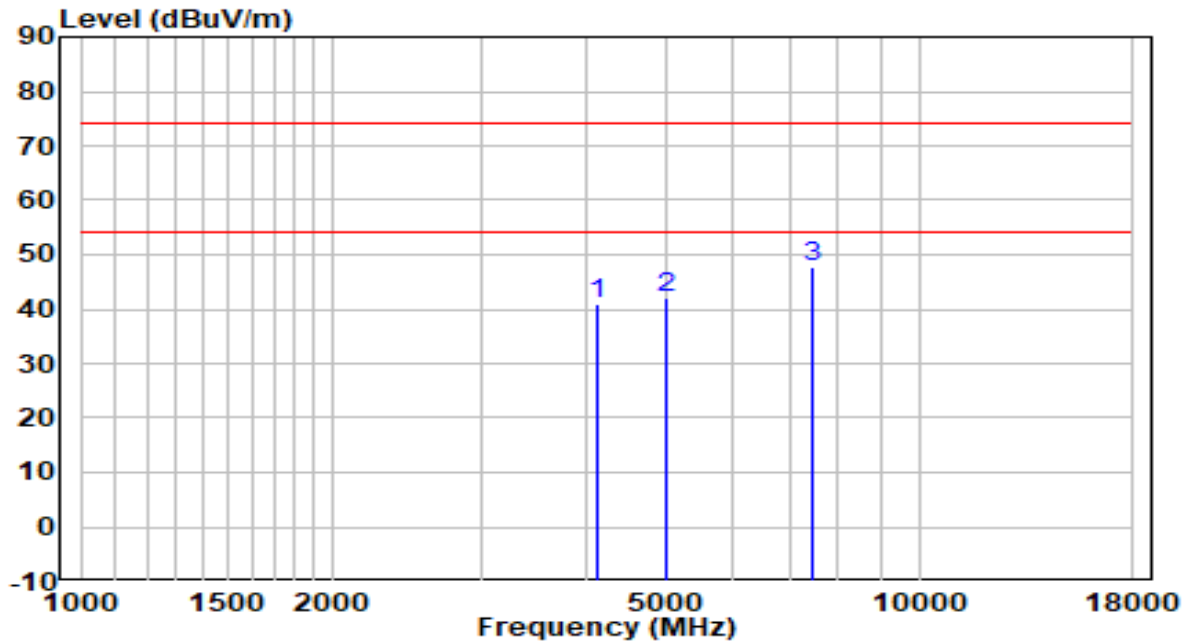

No	Frequency (MHz)	Reading (dBuV)	C.F (dB)	Measurement (dBuV/m)	Margin (dB)	Limit (dBuV/m)	Remark (QP/PK/AV)
1	4128.000	39.26	1.66	40.92	-33.08	74.00	Peak
2	4978.000	38.02	3.91	41.93	-32.07	74.00	Peak
3	* 7477.000	34.67	12.91	47.58	-26.42	74.00	Peak

Note:

1. " *", means this data is the worst emission level.
2. C.F (Correction Factor) = Antenna Factor (dB)+ Cable Loss (dB)– Preamplifier(dB).
3. Measurement(dBuV/m) = Reading(dBuV) + C.F (Correction Factor).
- 4.The emission levels of other frequencies are very lower than the limit and not show in test report.

EUT	ASSESS POINT	Date of Test	2021-11-07
Factor	BBHA 9120D (1GHz~18GHz)_2021	Temp. / Humidity	25.8°C/44.6%
Polarity	Vertical	Site / Test Engineer	AC1 / Jay
Test Mode	Transmit by Zigbee at Channel 2440MHz	Test Voltage	By PoE

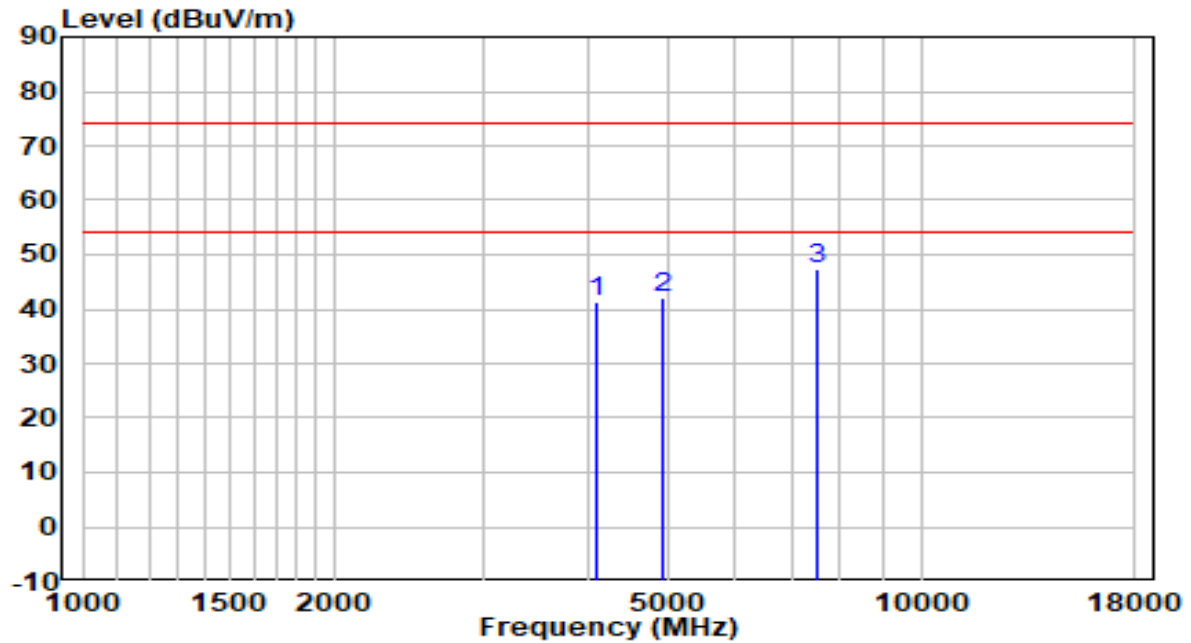

No	Frequency (MHz)	Reading (dBuV)	C.F (dB)	Measurement (dBuV/m)	Margin (dB)	Limit (dBuV/m)	Remark (QP/PK/AV)
1	4094.000	39.71	1.53	41.24	-32.76	74.00	Peak
2	4910.000	38.18	3.79	41.97	-32.03	74.00	Peak
3	* 7502.500	34.46	13.02	47.48	-26.52	74.00	Peak

Note:

1. " *", means this data is the worst emission level.
2. C.F (Correction Factor) = Antenna Factor (dB)+ Cable Loss (dB)– Preamplifier(dB).
3. Measurement(dBuV/m) = Reading(dBuV) + C.F (Correction Factor).
- 4.The emission levels of other frequencies are very lower than the limit and not show in test report.

EUT	ASSESS POINT	Date of Test	2021-11-07
Factor	BBHA 9120D (1GHz~18GHz)_2021	Temp. / Humidity	25.8°C/44.6%
Polarity	Horizontal	Site / Test Engineer	AC1 / Jay
Test Mode	Transmit by Zigbee at Channel 2480MHz	Test Voltage	By PoE

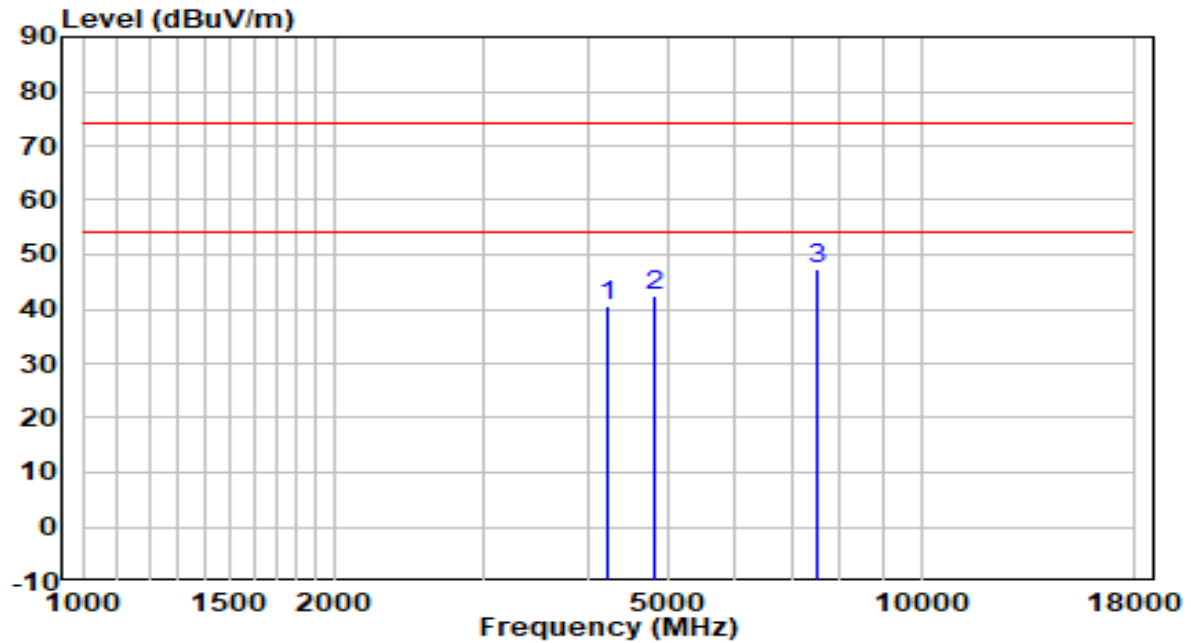

No	Frequency (MHz)	Reading (dBuV)	C.F (dB)	Measurement (dBuV/m)	Margin (dB)	Limit (dBuV/m)	Remark (QP/PK/AV)
1	4221.500	38.61	2.01	40.62	-33.38	74.00	Peak
2	4799.500	38.99	3.59	42.57	-31.43	74.00	Peak
3	* 7528.000	34.38	13.04	47.42	-26.58	74.00	Peak

Note:

1. " *", means this data is the worst emission level.
2. C.F (Correction Factor) = Antenna Factor (dB)+ Cable Loss (dB)– Preamplifier(dB).
3. Measurement(dBuV/m) = Reading(dBuV) + C.F (Correction Factor).
- 4.The emission levels of other frequencies are very lower than the limit and not show in test report.

EUT	ASSESS POINT	Date of Test	2021-11-07
Factor	BBHA 9120D (1GHz~18GHz)_2021	Temp. / Humidity	25.8°C/44.6%
Polarity	Vertical	Site / Test Engineer	AC1 / Jay
Test Mode	Transmit by Zigbee at Channel 2480MHz	Test Voltage	By PoE

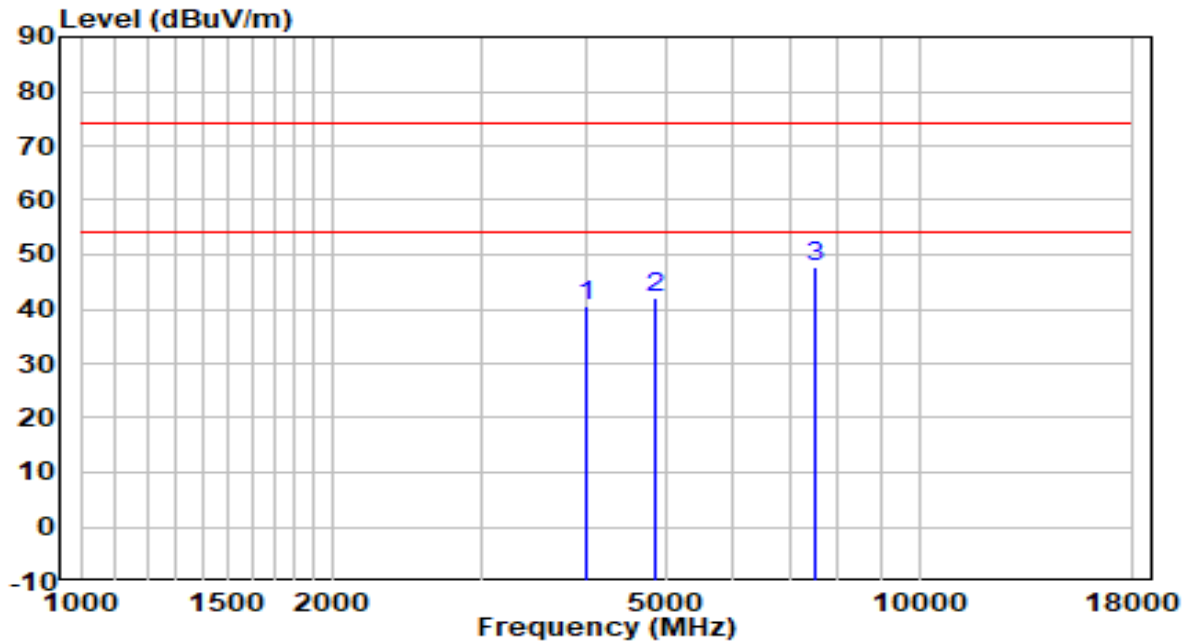

No	Frequency (MHz)	Reading (dBuV)	C.F (dB)	Measurement (dBuV/m)	Margin (dB)	Limit (dBuV/m)	Remark (QP/PK/AV)
1	4000.500	39.24	1.18	40.42	-33.58	74.00	Peak
2	4842.000	38.54	3.67	42.20	-31.80	74.00	Peak
3	* 7502.500	34.54	13.02	47.56	-26.44	74.00	Peak

Note:

1. " *", means this data is the worst emission level.
2. C.F (Correction Factor) = Antenna Factor (dB)+ Cable Loss (dB)– Preamplifier(dB).
3. Measurement(dBuV/m) = Reading(dBuV) + C.F (Correction Factor).
- 4.The emission levels of other frequencies are very lower than the limit and not show in test report.

APEX0587 Filter 5#:

EUT	ASSESS POINT	Date of Test	2021-11-07
Factor	BBHA 9120D (1GHz~18GHz)_2021	Temp. / Humidity	25.8°C/44.6%
Polarity	Horizontal	Site / Test Engineer	AC1 / Jay
Test Mode	Transmit by Zigbee at Channel 2405MHz	Test Voltage	By PoE

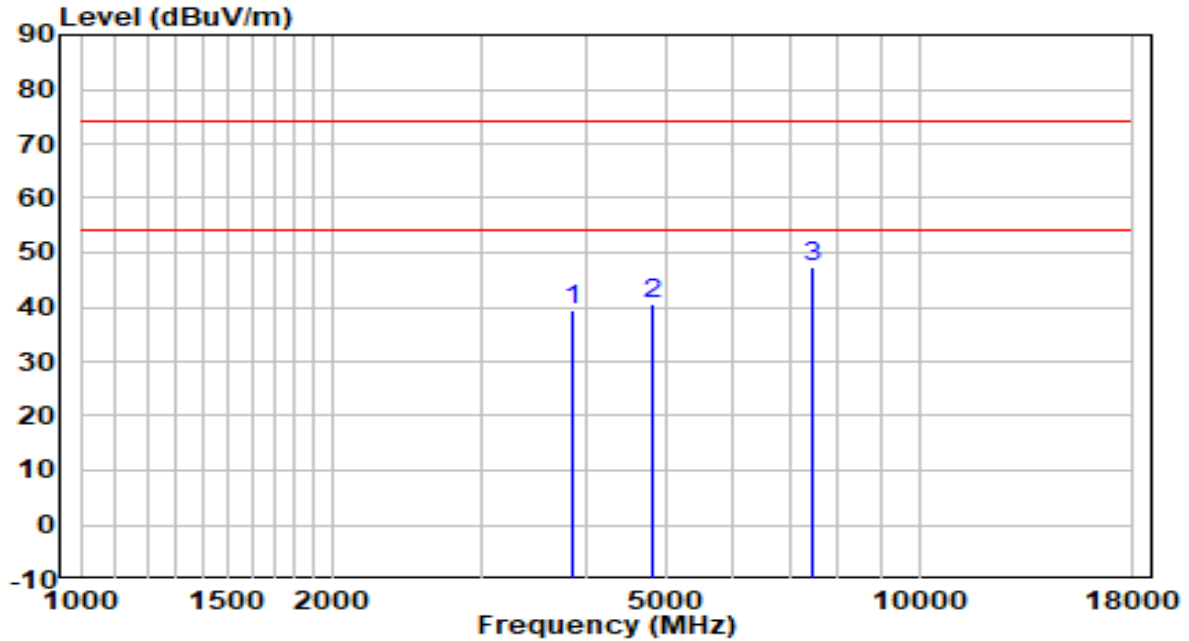

No	Frequency (MHz)	Reading (dBuV)	C.F (dB)	Measurement (dBuV/m)	Margin (dB)	Limit (dBuV/m)	Remark (QP/PK/AV)
1	3864.500	38.62	0.77	39.39	-34.61	74.00	Peak
2	4799.500	36.95	3.59	40.54	-33.46	74.00	Peak
3	* 7477.000	34.38	12.91	47.29	-26.71	74.00	Peak

Note:

1. " *", means this data is the worst emission level.
2. C.F (Correction Factor) = Antenna Factor (dB)+ Cable Loss (dB)– Preamplifier(dB).
3. Measurement(dBuV/m) = Reading(dBuV) + C.F (Correction Factor).
- 4.The emission levels of other frequencies are very lower than the limit and not show in test report.

EUT	ASSESS POINT	Date of Test	2021-11-07
Factor	BBHA 9120D (1GHz~18GHz)_2021	Temp. / Humidity	25.8°C/44.6%
Polarity	Vertical	Site / Test Engineer	AC1 / Jay
Test Mode	Transmit by Zigbee at Channel 2405MHz	Test Voltage	By PoE

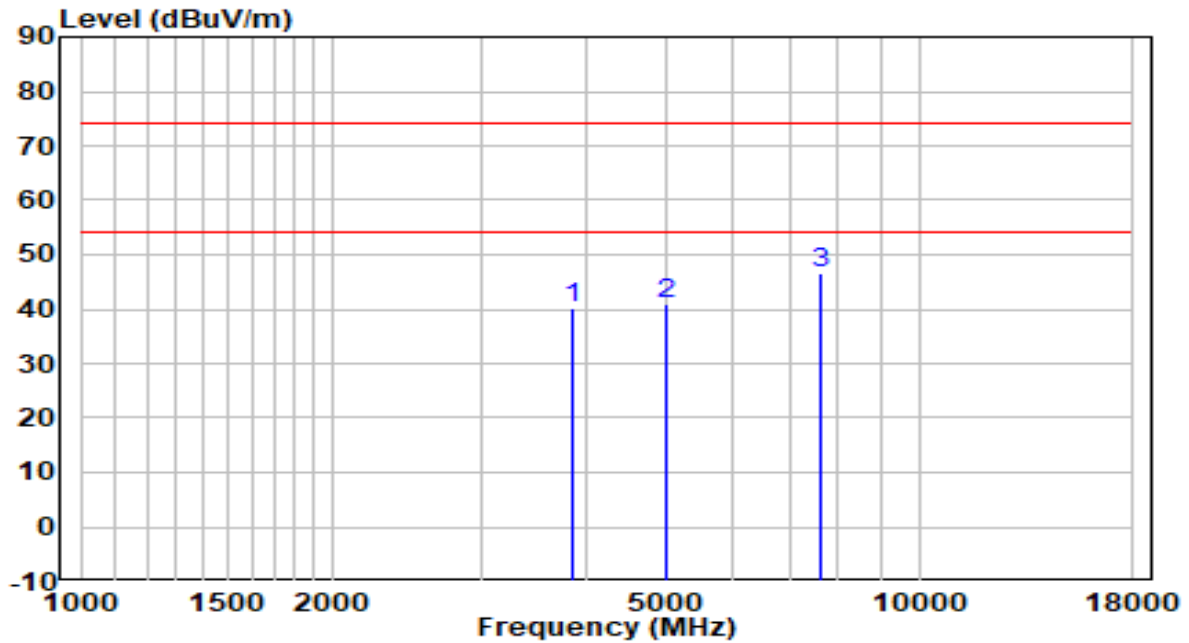

No	Frequency (MHz)	Reading (dBuV)	C.F (dB)	Measurement (dBuV/m)	Margin (dB)	Limit (dBuV/m)	Remark (QP/PK/AV)
1	3847.500	39.30	0.72	40.02	-33.98	74.00	Peak
2	4978.000	37.14	3.91	41.05	-32.95	74.00	Peak
3	* 7604.500	33.68	13.10	46.78	-27.22	74.00	Peak

Note:

1. " *", means this data is the worst emission level.
2. C.F (Correction Factor) = Antenna Factor (dB)+ Cable Loss (dB)– Preamplifier(dB).
3. Measurement(dBuV/m) = Reading(dBuV) + C.F (Correction Factor).
- 4.The emission levels of other frequencies are very lower than the limit and not show in test report.

APEX0587 Filter 6#:

EUT	ASSESS POINT	Date of Test	2021-11-07
Factor	BBHA 9120D (1GHz~18GHz)_2021	Temp. / Humidity	25.8°C/44.6%
Polarity	Horizontal	Site / Test Engineer	AC1 / Jay
Test Mode	Transmit by Zigbee at Channel 2480MHz	Test Voltage	By PoE

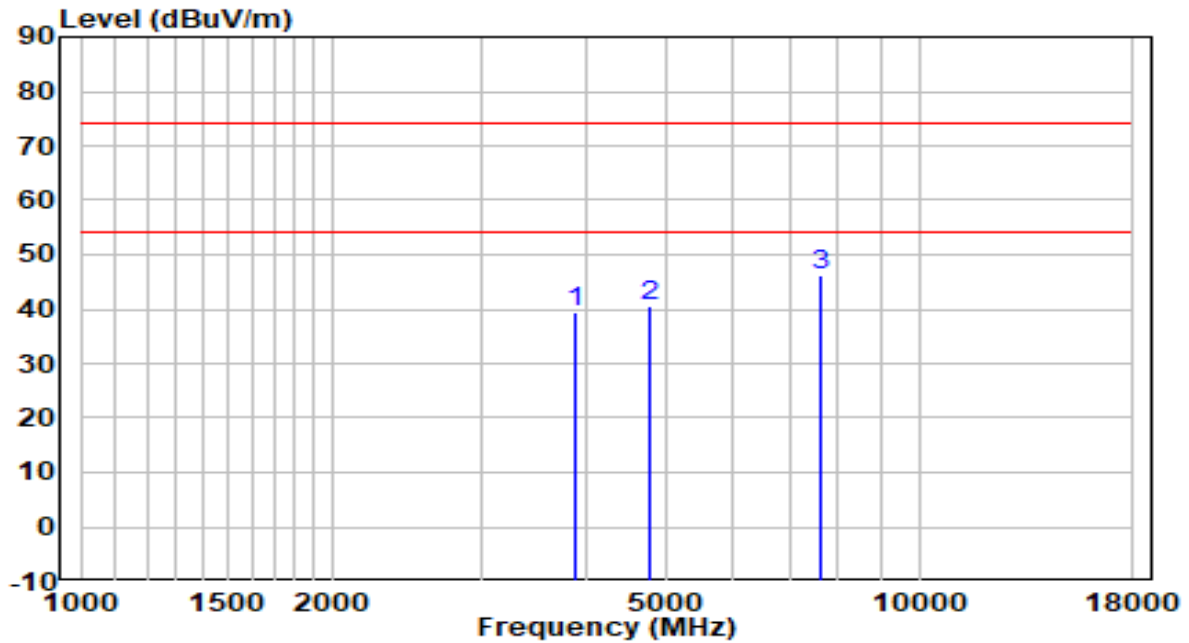

No	Frequency (MHz)	Reading (dBuV)	C.F (dB)	Measurement (dBuV/m)	Margin (dB)	Limit (dBuV/m)	Remark (QP/PK/AV)
1	3890.000	38.72	0.85	39.57	-34.43	74.00	Peak
2	4765.500	37.18	3.53	40.71	-33.29	74.00	Peak
3	* 7630.000	33.28	13.12	46.41	-27.59	74.00	Peak

Note:

1. " *", means this data is the worst emission level.
2. C.F (Correction Factor) = Antenna Factor (dB)+ Cable Loss (dB)– Preamplifier(dB).
3. Measurement(dBuV/m) = Reading(dBuV) + C.F (Correction Factor).
- 4.The emission levels of other frequencies are very lower than the limit and not show in test report.

EUT	ASSESS POINT	Date of Test	2021-11-07
Factor	BBHA 9120D (1GHz~18GHz)_2021	Temp. / Humidity	25.8°C/44.6%
Polarity	Vertical	Site / Test Engineer	AC1 / Jay
Test Mode	Transmit by Zigbee at Channel 2480MHz	Test Voltage	By PoE

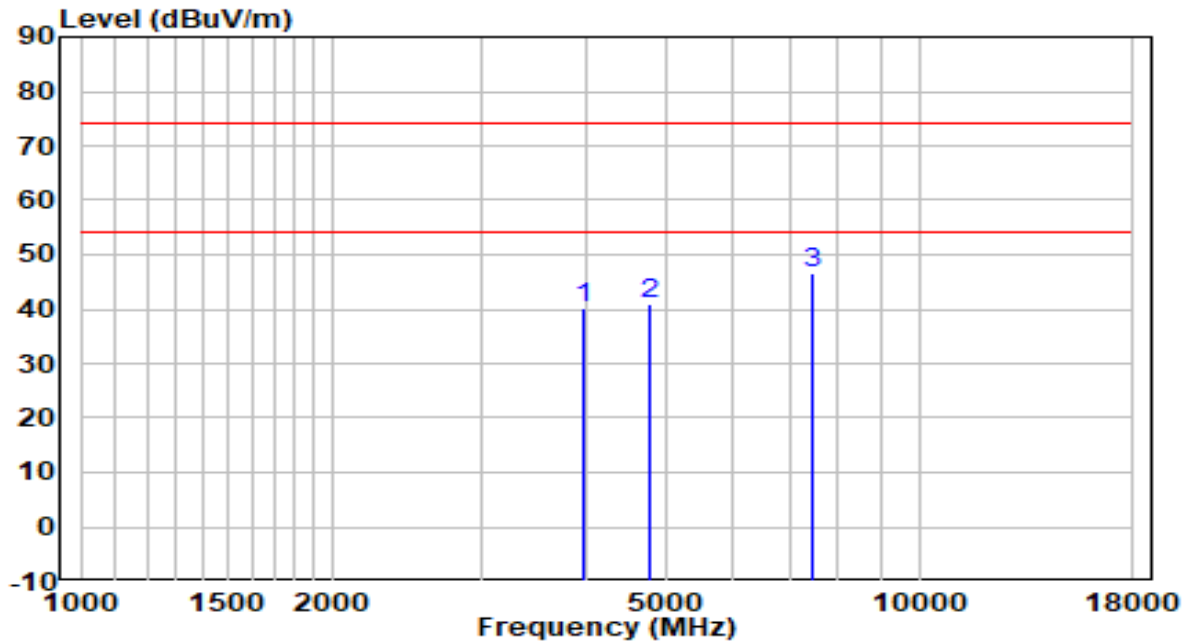

No	Frequency (MHz)	Reading (dBuV)	C.F (dB)	Measurement (dBuV/m)	Margin (dB)	Limit (dBuV/m)	Remark (QP/PK/AV)
1	3975.000	38.92	1.10	40.03	-33.97	74.00	Peak
2	4774.000	37.48	3.54	41.03	-32.97	74.00	Peak
3	* 7477.000	33.64	12.91	46.55	-27.45	74.00	Peak

Note:

1. " *", means this data is the worst emission level.
2. C.F (Correction Factor) = Antenna Factor (dB)+ Cable Loss (dB)– Preamplifier(dB).
3. Measurement(dBuV/m) = Reading(dBuV) + C.F (Correction Factor).
- 4.The emission levels of other frequencies are very lower than the limit and not show in test report.

APEX0584 Filter 4#:

EUT	ASSESS POINT	Date of Test	2021-11-07
Factor	BBHA 9120D (1GHz~18GHz)_2021	Temp. / Humidity	24.4°C/46.3%
Polarity	Horizontal	Site / Test Engineer	AC1 / Jay
Test Mode	Transmit by Zigbee at Channel 2405MHz	Test Voltage	By PoE

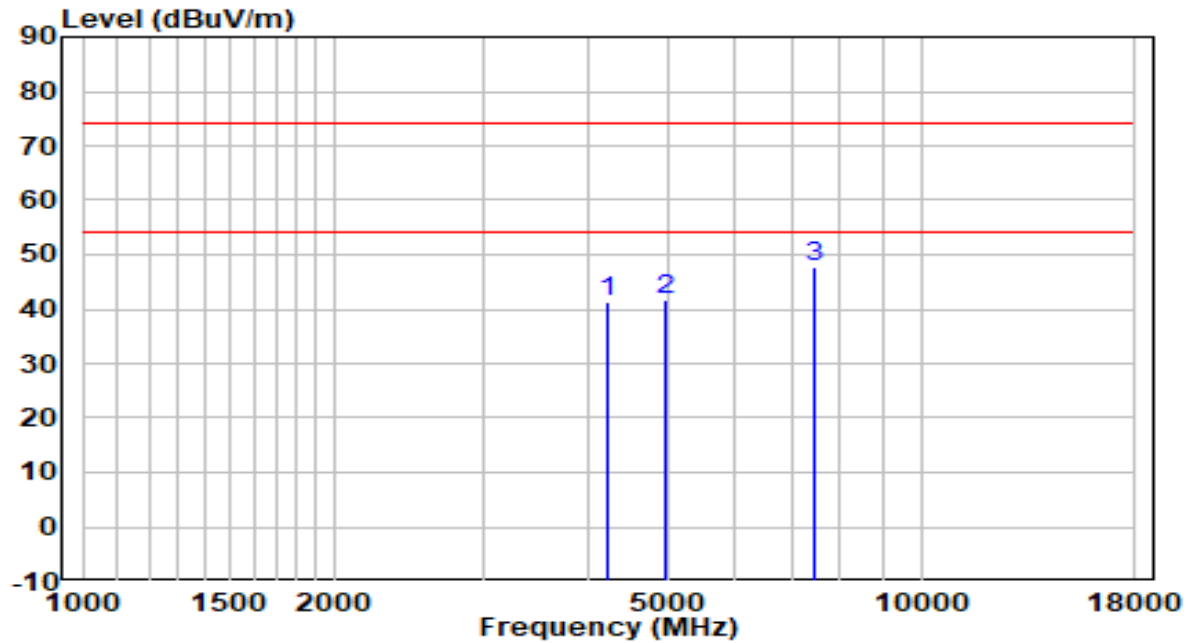

No	Frequency (MHz)	Reading (dBuV)	C.F (dB)	Measurement (dBuV/m)	Margin (dB)	Limit (dBuV/m)	Remark (QP/PK/AV)
1	4221.500	39.28	2.01	41.29	-32.71	74.00	Peak
2	4969.500	37.99	3.90	41.88	-32.12	74.00	Peak
3	* 7434.500	34.93	12.72	47.66	-26.34	74.00	Peak

Note:

1. " *", means this data is the worst emission level.
2. C.F (Correction Factor) = Antenna Factor (dB)+ Cable Loss (dB)– Preamplifier(dB).
3. Measurement(dBuV/m) = Reading(dBuV) + C.F (Correction Factor).
- 4.The emission levels of other frequencies are very lower than the limit and not show in test report.

EUT	ASSESS POINT	Date of Test	2021-11-07
Factor	BBHA 9120D (1GHz~18GHz)_2021	Temp. / Humidity	24.4°C/46.3%
Polarity	Vertical	Site / Test Engineer	AC1 / Jay
Test Mode	Transmit by Zigbee at Channel 2405MHz	Test Voltage	By PoE

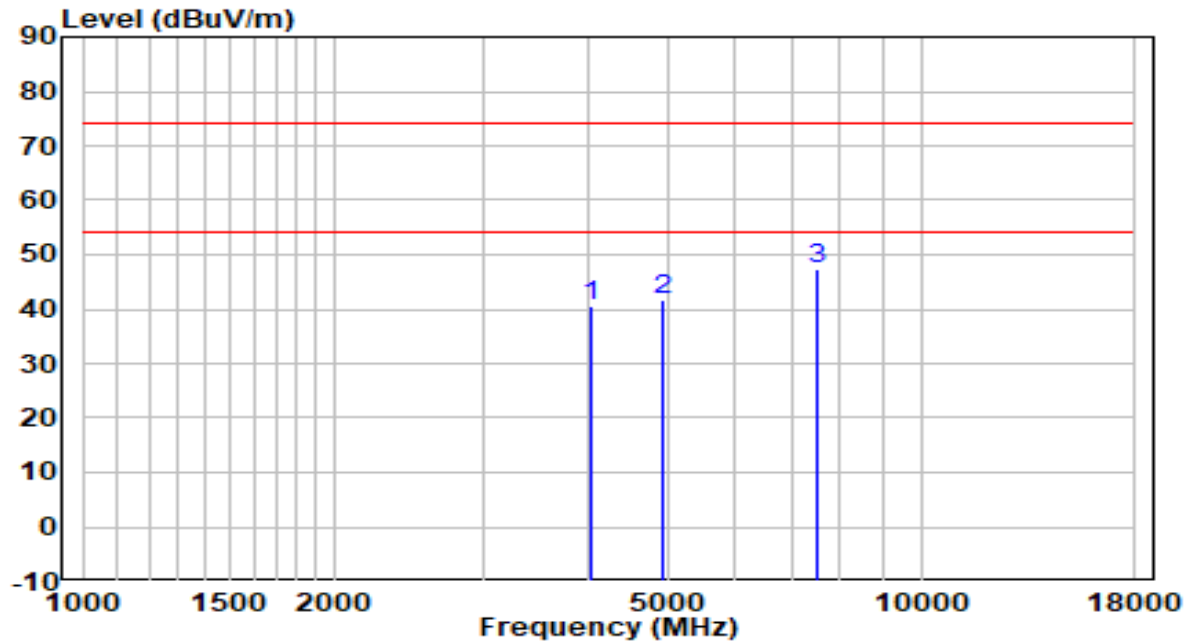

No	Frequency (MHz)	Reading (dBuV)	C.F (dB)	Measurement (dBuV/m)	Margin (dB)	Limit (dBuV/m)	Remark (QP/PK/AV)
1	4026.000	39.33	1.28	40.61	-33.39	74.00	Peak
2	4910.000	37.98	3.79	41.77	-32.23	74.00	Peak
3	* 7536.500	34.17	13.05	47.22	-26.78	74.00	Peak

Note:

1. " *", means this data is the worst emission level.
2. C.F (Correction Factor) = Antenna Factor (dB)+ Cable Loss (dB)– Preamplifier(dB).
3. Measurement(dBuV/m) = Reading(dBuV) + C.F (Correction Factor).
- 4.The emission levels of other frequencies are very lower than the limit and not show in test report.

EUT	ASSESS POINT	Date of Test	2021-11-07
Factor	BBHA 9120D (1GHz~18GHz)_2021	Temp. / Humidity	24.4°C/46.3%
Polarity	Horizontal	Site / Test Engineer	AC1 / Jay
Test Mode	Transmit by Zigbee at Channel 2440MHz	Test Voltage	By PoE

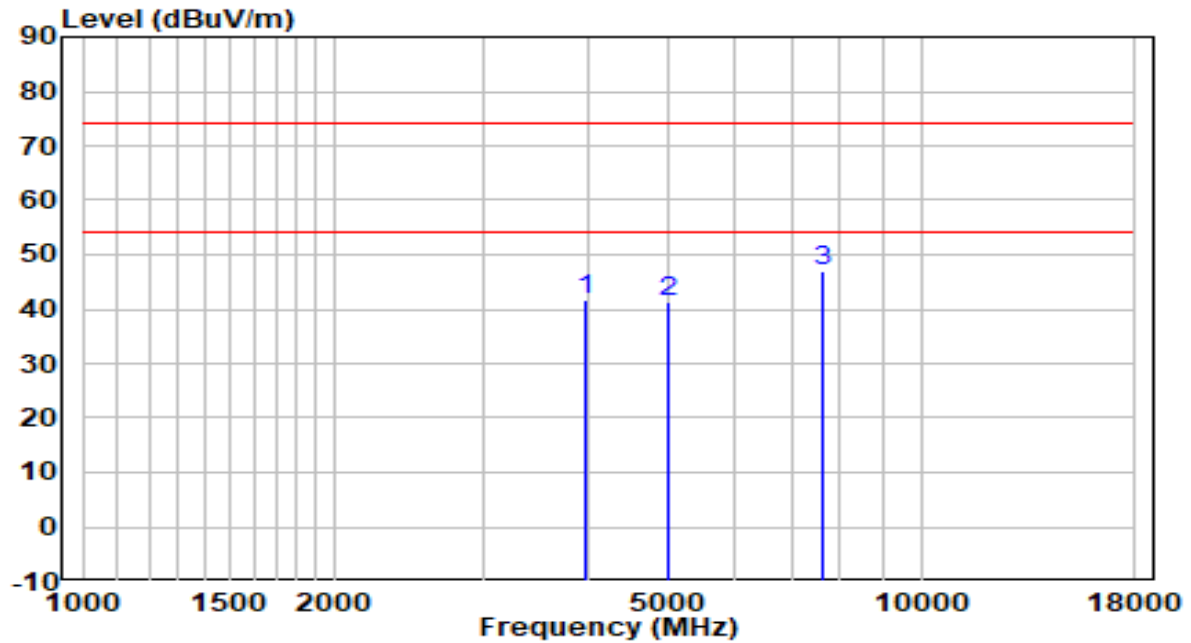

No	Frequency (MHz)	Reading (dBuV)	C.F (dB)	Measurement (dBuV/m)	Margin (dB)	Limit (dBuV/m)	Remark (QP/PK/AV)
1	3975.000	40.48	1.10	41.58	-32.42	74.00	Peak
2	5003.500	37.50	3.96	41.46	-32.54	74.00	Peak
3	* 7604.500	34.05	13.10	47.15	-26.85	74.00	Peak

Note:

1. "*" , means this data is the worst emission level.
2. C.F (Correction Factor) = Antenna Factor (dB)+ Cable Loss (dB)– Preamplifier(dB).
3. Measurement(dBuV/m) = Reading(dBuV) + C.F (Correction Factor).
- 4.The emission levels of other frequencies are very lower than the limit and not show in test report.

EUT	ASSESS POINT	Date of Test	2021-11-07
Factor	BBHA 9120D (1GHz~18GHz)_2021	Temp. / Humidity	24.4°C/46.3%
Polarity	Vertical	Site / Test Engineer	AC1 / Jay
Test Mode	Transmit by Zigbee at Channel 2440MHz	Test Voltage	By PoE

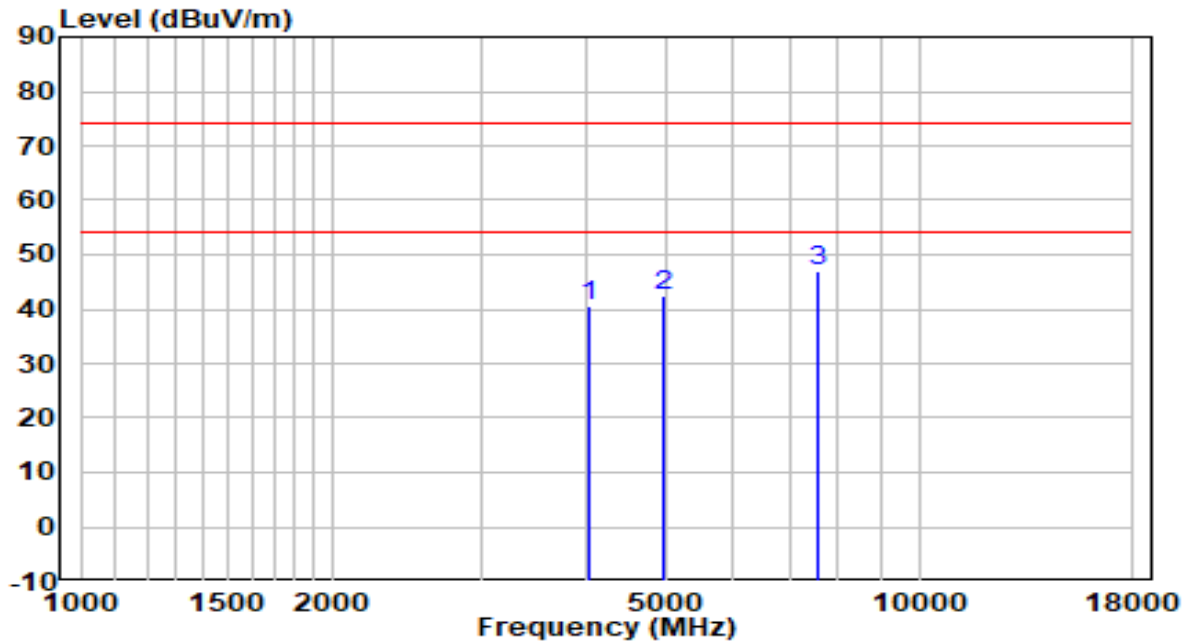

No	Frequency (MHz)	Reading (dBuV)	C.F (dB)	Measurement (dBuV/m)	Margin (dB)	Limit (dBuV/m)	Remark (QP/PK/AV)
1	4034.500	39.44	1.31	40.75	-33.25	74.00	Peak
2	4952.500	38.77	3.86	42.64	-31.36	74.00	Peak
3	* 7579.000	33.84	13.08	46.92	-27.08	74.00	Peak

Note:

1. " *", means this data is the worst emission level.
2. C.F (Correction Factor) = Antenna Factor (dB)+ Cable Loss (dB)– Preamplifier(dB).
3. Measurement(dBuV/m) = Reading(dBuV) + C.F (Correction Factor).
- 4.The emission levels of other frequencies are very lower than the limit and not show in test report.

EUT	ASSESS POINT	Date of Test	2021-11-07
Factor	BBHA 9120D (1GHz~18GHz)_2021	Temp. / Humidity	24.4°C/46.3%
Polarity	Horizontal	Site / Test Engineer	AC1 / Jay
Test Mode	Transmit by Zigbee at Channel 2480MHz	Test Voltage	By PoE

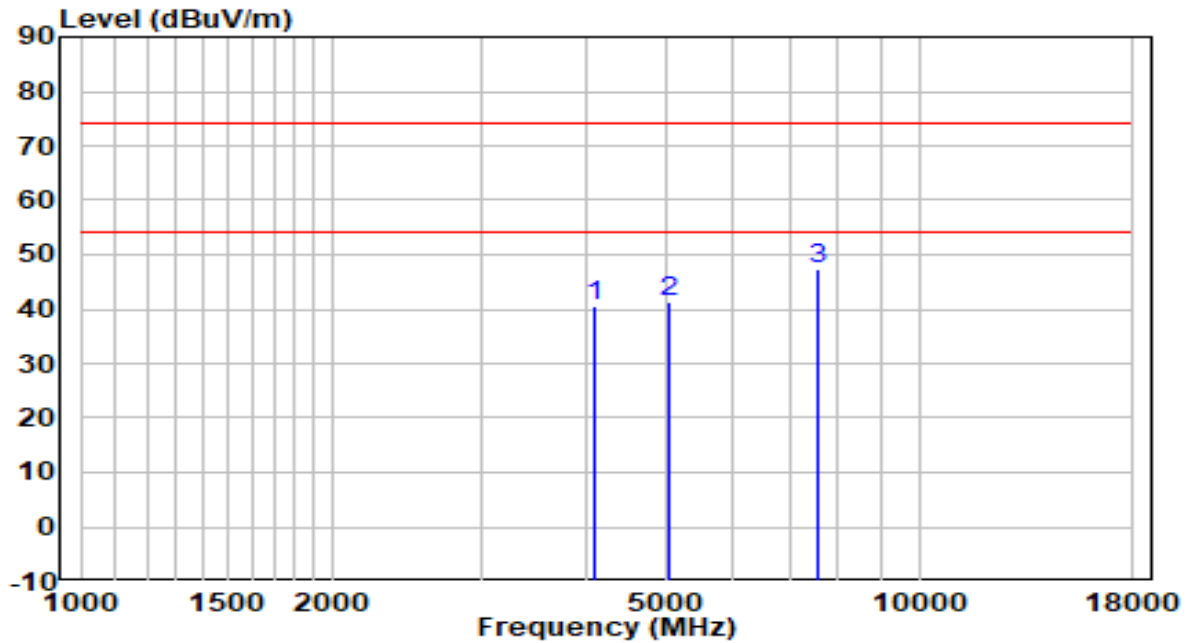

No	Frequency (MHz)	Reading (dBuV)	C.F (dB)	Measurement (dBuV/m)	Margin (dB)	Limit (dBuV/m)	Remark (QP/PK/AV)
1	4094.000	38.91	1.53	40.44	-33.56	74.00	Peak
2	5020.500	37.46	3.98	41.44	-32.56	74.00	Peak
3	* 7553.500	34.14	13.06	47.20	-26.80	74.00	Peak

Note:

1. " *", means this data is the worst emission level.
2. C.F (Correction Factor) = Antenna Factor (dB)+ Cable Loss (dB)– Preamplifier(dB).
3. Measurement(dBuV/m) = Reading(dBuV) + C.F (Correction Factor).
- 4.The emission levels of other frequencies are very lower than the limit and not show in test report.

EUT	ASSESS POINT	Date of Test	2021-11-07
Factor	BBHA 9120D (1GHz~18GHz)_2021	Temp. / Humidity	24.4°C/46.3%
Polarity	Vertical	Site / Test Engineer	AC1 / Jay
Test Mode	Transmit by Zigbee at Channel 2480MHz	Test Voltage	By PoE

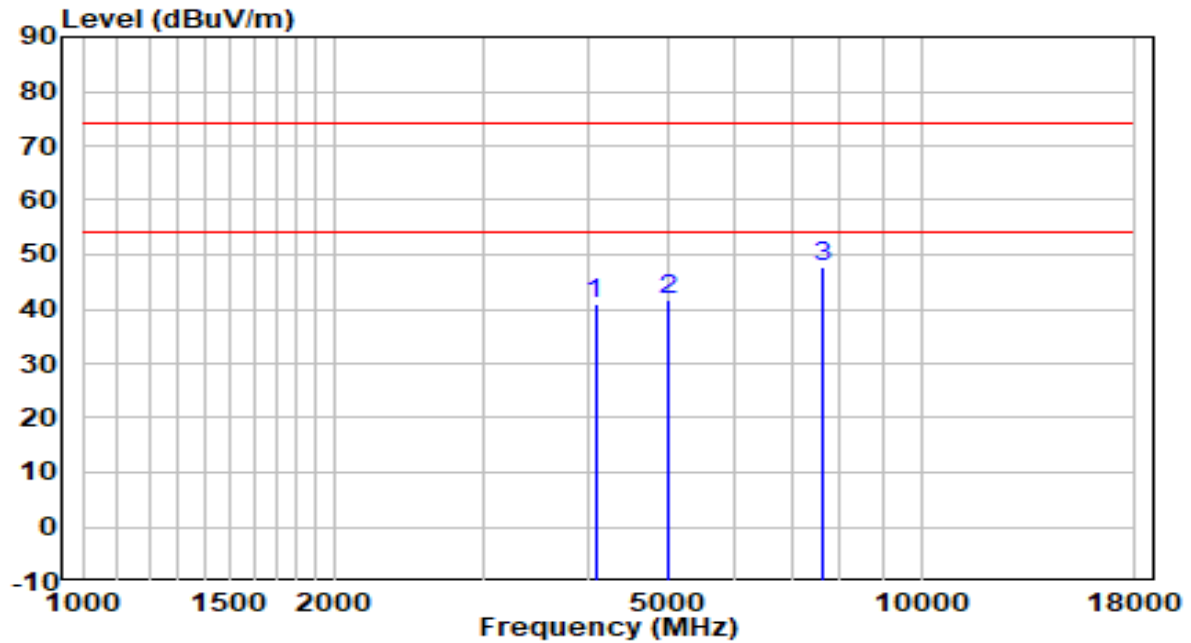

No	Frequency (MHz)	Reading (dBuV)	C.F (dB)	Measurement (dBuV/m)	Margin (dB)	Limit (dBuV/m)	Remark (QP/PK/AV)
1	4085.500	39.60	1.50	41.10	-32.90	74.00	Peak
2	4986.500	37.92	3.93	41.84	-32.16	74.00	Peak
3	* 7638.500	34.55	13.13	47.68	-26.32	74.00	Peak

Note:

1. " *", means this data is the worst emission level.
2. C.F (Correction Factor) = Antenna Factor (dB)+ Cable Loss (dB)– Preamplifier(dB).
3. Measurement(dBuV/m) = Reading(dBuV) + C.F (Correction Factor).
- 4.The emission levels of other frequencies are very lower than the limit and not show in test report.

APEX0584 Filter 5#:

EUT	ASSESS POINT	Date of Test	2021-11-07
Factor	BBHA 9120D (1GHz~18GHz)_2021	Temp. / Humidity	24.4°C/46.2%
Polarity	Horizontal	Site / Test Engineer	AC1 / Jay
Test Mode	Transmit by Zigbee at Channel 2405MHz	Test Voltage	By PoE

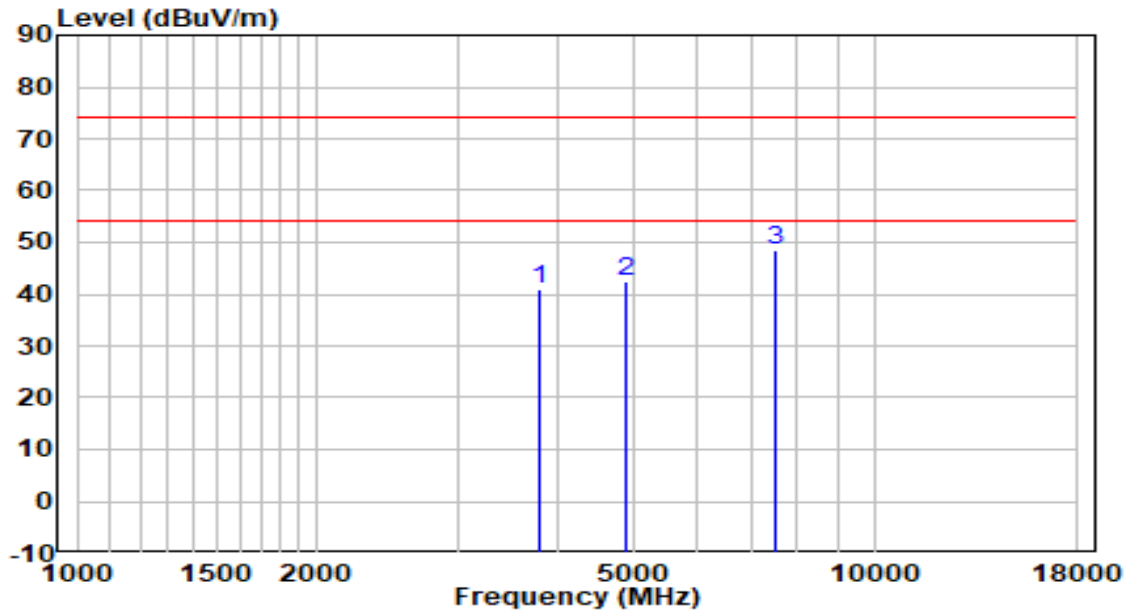

No	Frequency (MHz)	Reading (dBUV)	C.F (dB)	Measurement (dBUV/m)	Margin (dB)	Limit (dBUV/m)	Remark (QP/PK/AV)
1	3813.500	40.40	0.61	41.01	-32.99	74.00	Peak
2	4876.000	38.89	3.73	42.61	-31.39	74.00	Peak
3	* 7528.000	35.29	13.04	48.33	-25.67	74.00	Peak

Note:

1. " *", means this data is the worst emission level.
2. C.F (Correction Factor) = Antenna Factor (dB)+ Cable Loss (dB)– Preamplifier(dB).
3. Measurement(dBUV/m) = Reading(dBUV) + C.F (Correction Factor).
- 4.The emission levels of other frequencies are very lower than the limit and not show in test report.

EUT	ASSESS POINT	Date of Test	2021-11-07
Factor	BBHA 9120D (1GHz~18GHz)_2021	Temp. / Humidity	24.4°C/46.2%
Polarity	Vertical	Site / Test Engineer	AC1 / Jay
Test Mode	Transmit by Zigbee at Channel 2405MHz	Test Voltage	By PoE

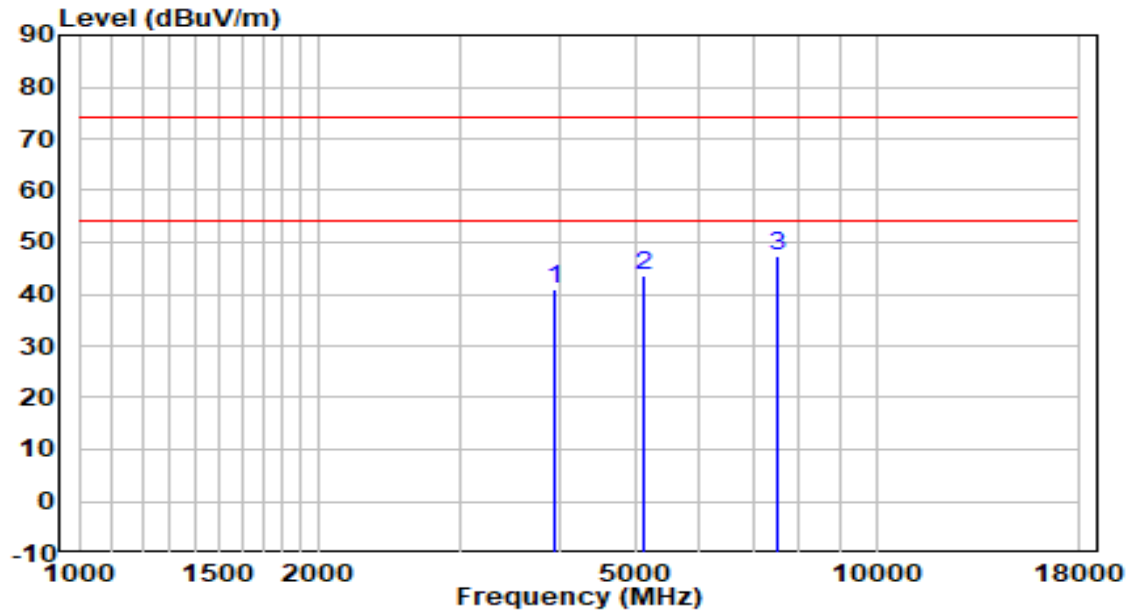

No	Frequency (MHz)	Reading (dBuV)	C.F (dB)	Measurement (dBuV/m)	Margin (dB)	Limit (dBuV/m)	Remark (QP/PK/AV)
1	3949.500	40.07	1.03	41.10	-32.90	74.00	Peak
2	5097.000	39.30	4.11	43.41	-30.59	74.00	Peak
3	* 7511.000	34.43	13.02	47.46	-26.54	74.00	Peak

Note:

1. " *", means this data is the worst emission level.
2. C.F (Correction Factor) = Antenna Factor (dB)+ Cable Loss (dB)– Preamplifier(dB).
3. Measurement(dBuV/m) = Reading(dBuV) + C.F (Correction Factor).
- 4.The emission levels of other frequencies are very lower than the limit and not show in test report.

APEX0584 Filter 6#:

EUT	ASSESS POINT	Date of Test	2021-11-07
Factor	BBHA 9120D (1GHz~18GHz)_2021	Temp. / Humidity	24.4°C/46.2%
Polarity	Horizontal	Site / Test Engineer	AC1 / Jay
Test Mode	Transmit by Zigbee at Channel 2480MHz	Test Voltage	By PoE

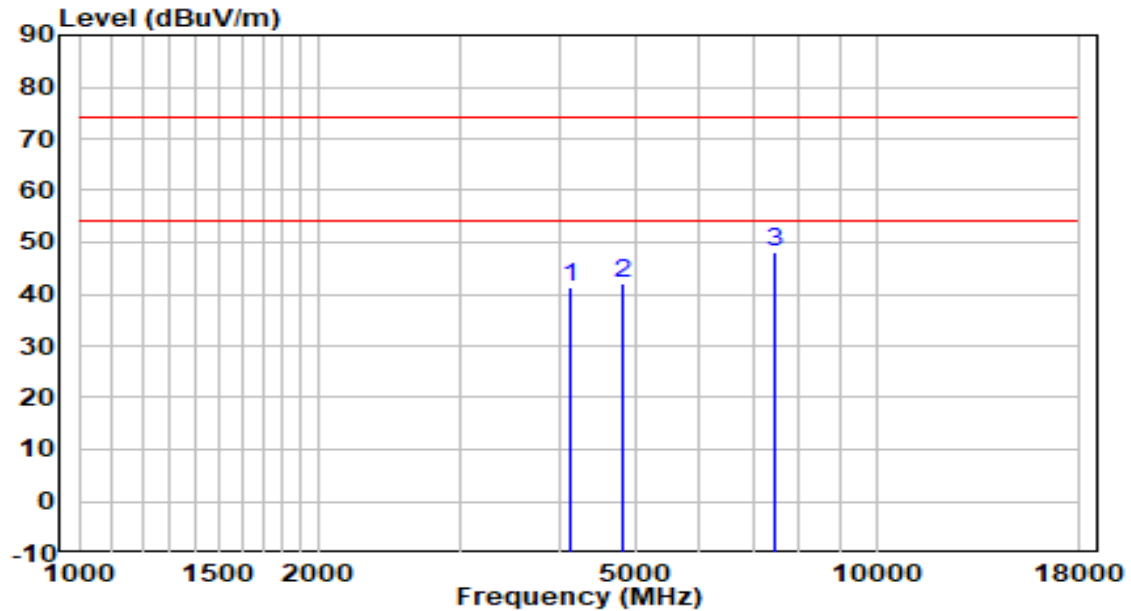

No	Frequency (MHz)	Reading (dBuV)	C.F (dB)	Measurement (dBuV/m)	Margin (dB)	Limit (dBuV/m)	Remark (QP/PK/AV)
1	4119.500	39.56	1.63	41.19	-32.81	74.00	Peak
2	4825.000	38.25	3.64	41.89	-32.11	74.00	Peak
3	* 7451.500	35.15	12.80	47.95	-26.05	74.00	Peak

Note:

1. " *", means this data is the worst emission level.
2. C.F (Correction Factor) = Antenna Factor (dB)+ Cable Loss (dB)– Preamplifier(dB).
3. Measurement(dBuV/m) = Reading(dBuV) + C.F (Correction Factor).
- 4.The emission levels of other frequencies are very lower than the limit and not show in test report.

EUT	ASSESS POINT	Date of Test	2021-11-07
Factor	BBHA 9120D (1GHz~18GHz)_2021	Temp. / Humidity	24.4°C/46.2%
Polarity	Vertical	Site / Test Engineer	AC1 / Jay
Test Mode	Transmit by Zigbee at Channel 2480MHz	Test Voltage	By PoE

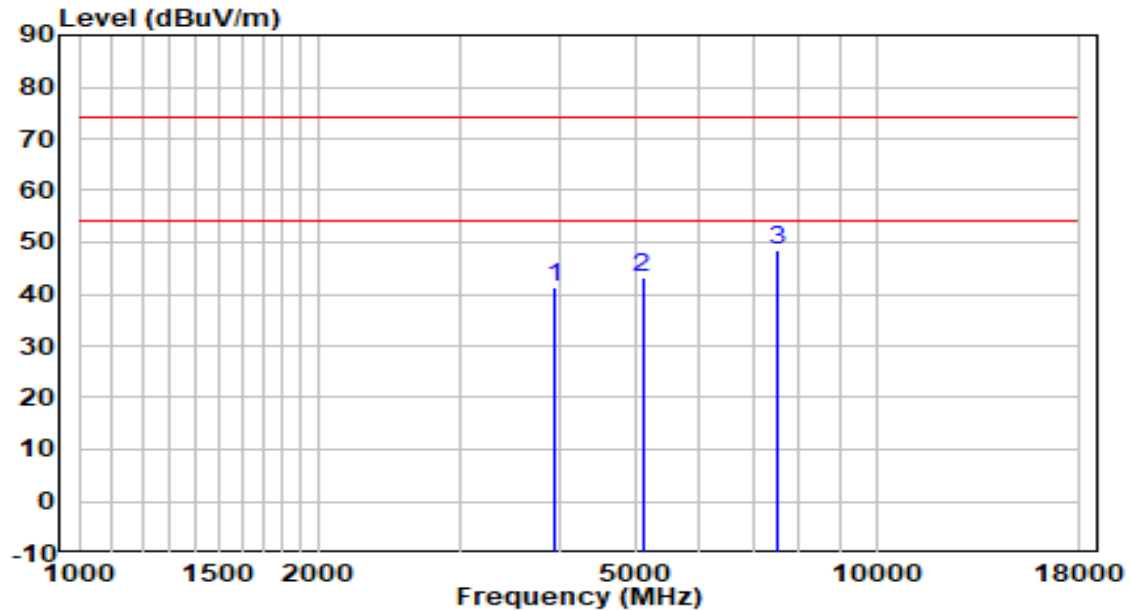

No	Frequency (MHz)	Reading (dBuV)	C.F (dB)	Measurement (dBuV/m)	Margin (dB)	Limit (dBuV/m)	Remark (QP/PK/AV)
1	3949.500	40.48	1.03	41.51	-32.49	74.00	Peak
2	5088.500	38.95	4.10	43.05	-30.95	74.00	Peak
3	* 7536.500	35.28	13.05	48.33	-25.67	74.00	Peak

Note:

1. " *", means this data is the worst emission level.
2. C.F (Correction Factor) = Antenna Factor (dB)+ Cable Loss (dB)– Preamplifier(dB).
3. Measurement(dBuV/m) = Reading(dBuV) + C.F (Correction Factor).
- 4.The emission levels of other frequencies are very lower than the limit and not show in test report.

The Result of Radiated Spurious Emission below 1GHz:

EUT	ACCESS POINT (APEX0585)	Date of Test	2021-11-03
Factor	VULB 9162 (30MHz~8GHz) + 6dB Attenuator_2020	Temp. / Humidity	25.1°C /43%
Polarity	Horizontal	Site / Test Engineer	AC1 / Jay
Test Mode	Transmit by Zigbee at Channel 2405MHz	Test Voltage	By PoE

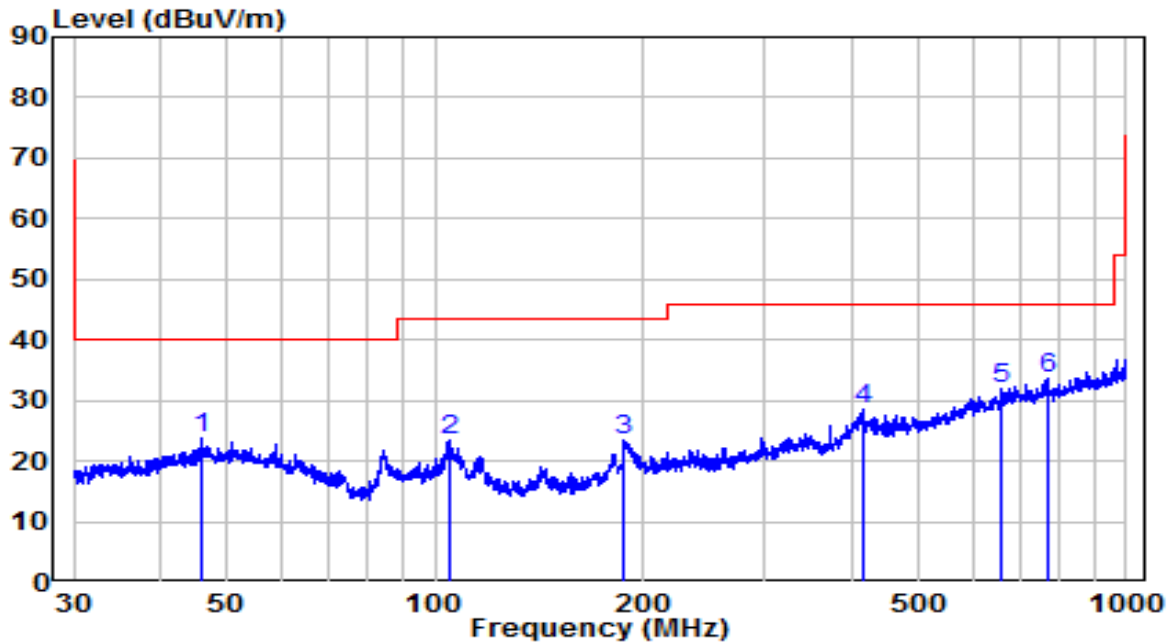

No	Frequency (MHz)	Reading (dBuV)	C.F (dB/m)	Measurement (dBuV/m)	Margin (dB)	Limit (dBuV/m)	Remark (QP/PK/AV)
1	45.936	2.62	21.24	23.86	-16.14	40.00	Peak
2	104.720	5.48	17.96	23.45	-20.05	43.50	Peak
3	187.424	6.07	17.21	23.28	-20.22	43.50	Peak
4	415.450	6.32	22.32	28.63	-17.37	46.00	Peak
5	659.992	5.55	26.22	31.77	-14.23	46.00	Peak
6	* 770.097	6.17	27.52	33.69	-12.31	46.00	Peak

Note:

- " *", means this data is the worst emission level.
- C.F (Correction Factor) = Antenna Factor (dB/m) + Cable Loss (dB).
- Measurement(dBuV/m) = Reading(dBuV) + C.F (Correction Factor).
- The emission levels of other frequencies are very lower than the limit and not show in test report.
- QP measurement was not performed when peak measure level was lower than the QP limit.

EUT	ACCESS POINT (APEX0585)	Date of Test	2021-11-03
Factor	VULB 9162 (30MHz~8GHz) + 6dB Attenuator_2020	Temp. / Humidity	25.1°C /43%
Polarity	Vertical	Site / Test Engineer	AC1 / Jay
Test Mode	Transmit by Zigbee at Channel 2405MHz	Test Voltage	By PoE

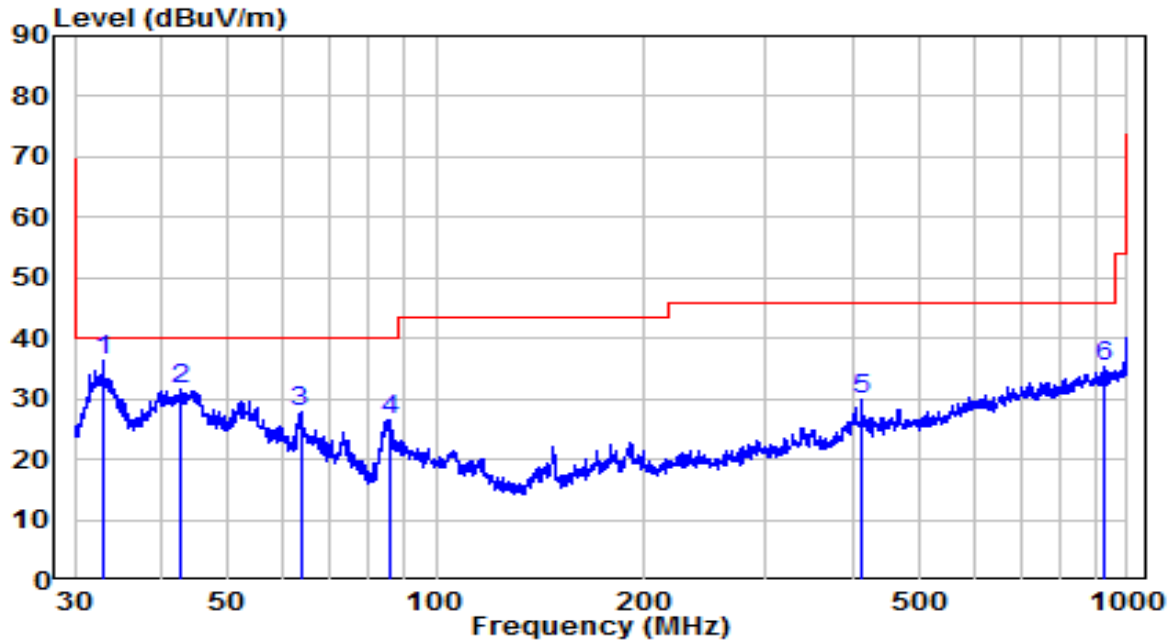

No	Frequency (MHz)	Reading (dBuV)	C.F (dB/m)	Measurement (dBuV/m)	Margin (dB)	Limit (dBuV/m)	Remark (QP/PK/AV)	
1	*	32.979	17.93	18.44	36.37	-3.63	40.00	Peak
2		42.525	10.77	20.85	31.62	-8.38	40.00	Peak
3		63.647	9.60	18.30	27.90	-12.10	40.00	Peak
4		85.448	11.79	14.86	26.65	-13.35	40.00	Peak
5		413.271	7.43	22.29	29.72	-16.28	46.00	Peak
6		922.516	6.25	28.94	35.19	-10.81	46.00	Peak

Note:

1. " *", means this data is the worst emission level.
2. C.F (Correction Factor) = Antenna Factor (dB/m) + Cable Loss (dB).
3. Measurement(dBuV/m) = Reading(dBuV) + C.F (Correction Factor).
4. The emission levels of other frequencies are very lower than the limit and not show in test report.
5. QP measurement was not performed when peak measure level was lower than the QP limit.

EUT	ACCESS POINT (APEX0587)	Date of Test	2021-11-03
Factor	VULB 9162 (30MHz~8GHz) + 6dB Attenuator_2020	Temp. / Humidity	25.1°C /43%
Polarity	Horizontal	Site / Test Engineer	AC1 / Jay
Test Mode	Transmit by Zigbee at Channel 2405MHz	Test Voltage	By PoE

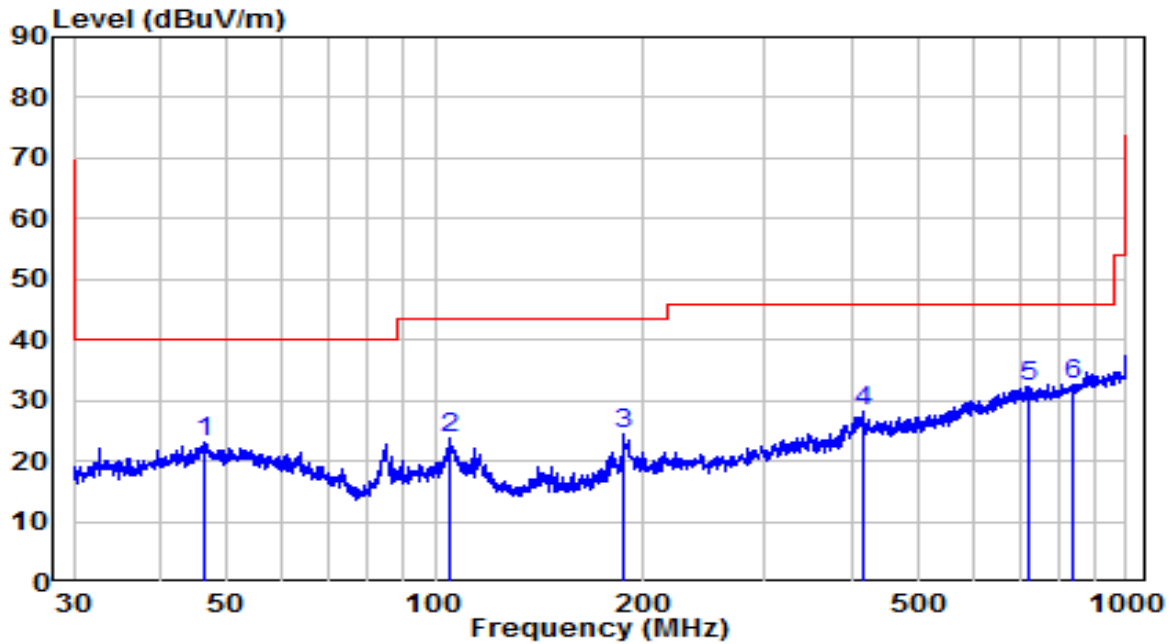

No	Frequency (MHz)	Reading (dBuV)	C.F (dB/m)	Measurement (dBuV/m)	Margin (dB)	Limit (dBuV/m)	Remark (QP/PK/AV)
1	46.340	1.71	21.25	22.96	-17.04	40.00	Peak
2	105.457	5.87	17.93	23.79	-19.71	43.50	Peak
3	187.753	7.06	17.26	24.32	-19.18	43.50	Peak
4	416.910	5.76	22.34	28.09	-17.91	46.00	Peak
5	720.462	5.45	26.99	32.43	-13.57	46.00	Peak
6	* 837.712	4.38	28.38	32.76	-13.24	46.00	Peak

Note:

1. " *", means this data is the worst emission level.
2. C.F (Correction Factor) = Antenna Factor (dB/m) + Cable Loss (dB).
3. Measurement(dBuV/m) = Reading(dBuV) + C.F (Correction Factor).
4. The emission levels of other frequencies are very lower than the limit and not show in test report.
5. QP measurement was not performed when peak measure level was lower than the QP limit.

EUT	ACCESS POINT (APEX0587)	Date of Test	2021-11-03
Factor	VULB 9162 (30MHz~8GHz) + 6dB Attenuator_2020	Temp. / Humidity	25.1°C / 43%
Polarity	Vertical	Site / Test Engineer	AC1 / Jay
Test Mode	Transmit by Zigbee at Channel 2405MHz	Test Voltage	By PoE

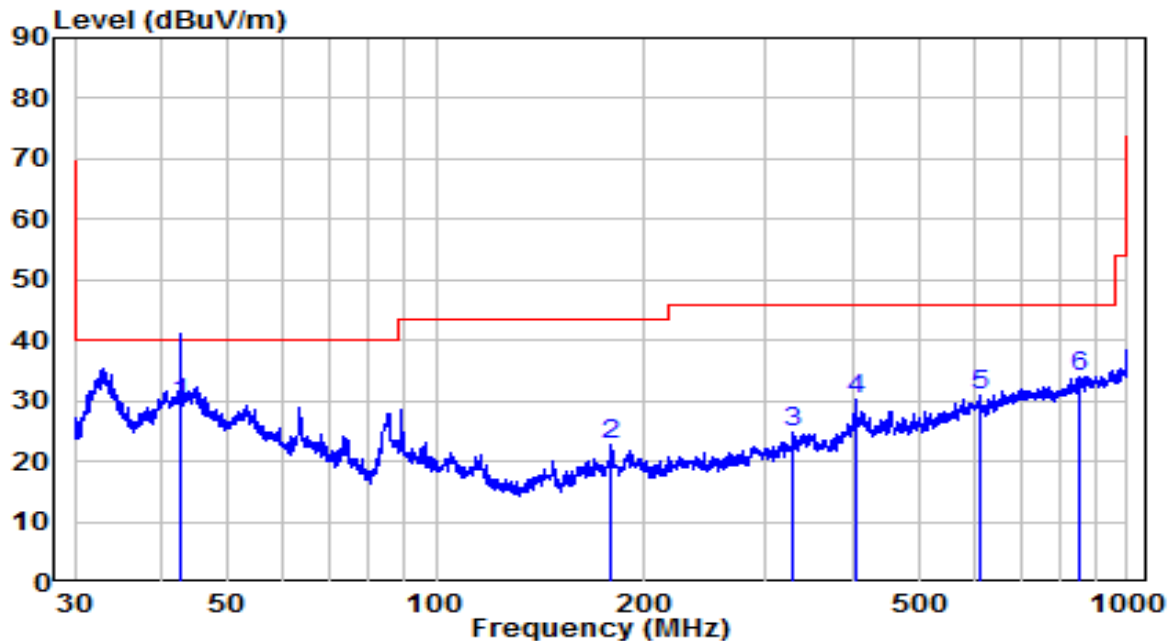

No	Frequency (MHz)	Reading (dBuV)	C.F (dB/m)	Measurement (dBuV/m)	Margin (dB)	Limit (dBuV/m)	Remark (QP/PK/AV)	
1	*	42.675	8.53	20.87	29.40	-10.60	40.00	QP
2		179.386	6.68	16.06	22.74	-20.76	43.50	Peak
3		328.463	3.99	20.71	24.70	-21.30	46.00	Peak
4		406.088	7.92	22.19	30.11	-15.89	46.00	Peak
5		613.138	5.45	25.58	31.03	-14.97	46.00	Peak
6		854.025	5.26	28.62	33.88	-12.12	46.00	Peak

Note:

- "*", means this data is the worst emission level.
- C.F (Correction Factor) = Antenna Factor (dB/m) + Cable Loss (dB).
- Measurement(dBuV/m) = Reading(dBuV) + C.F (Correction Factor).
- The emission levels of other frequencies are very lower than the limit and not show in test report.
- QP measurement was not performed when peak measure level was lower than the QP limit.

EUT	ACCESS POINT (APEX0584)	Date of Test	2021-11-03
Factor	VULB 9162 (30MHz~8GHz) + 6dB Attenuator_2020	Temp. / Humidity	25.1°C /43%
Polarity	Horizontal	Site / Test Engineer	AC1 / Jay
Test Mode	Transmit by Zigbee at Channel 2405MHz	Test Voltage	By PoE

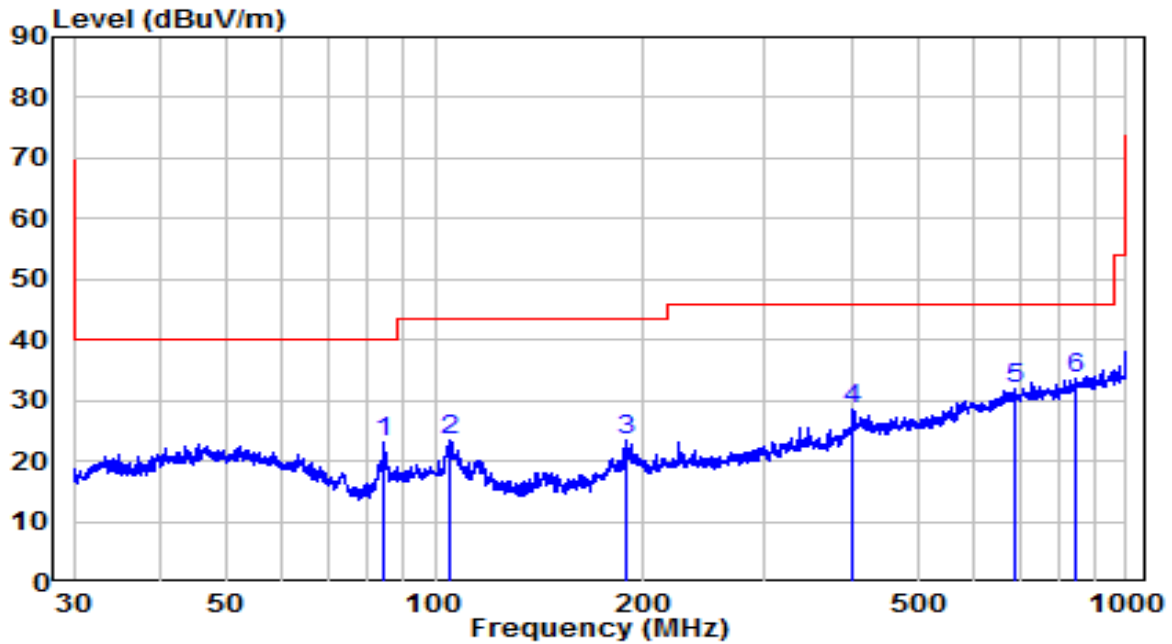

No	Frequency (MHz)	Reading (dBuV)	C.F (dB/m)	Measurement (dBuV/m)	Margin (dB)	Limit (dBuV/m)	Remark (QP/PK/AV)
1	84.258	8.69	14.56	23.26	-16.74	40.00	Peak
2	105.087	5.40	17.95	23.34	-20.16	43.50	Peak
3	189.406	5.94	17.51	23.45	-20.05	43.50	Peak
4	402.544	6.29	22.14	28.42	-17.58	46.00	Peak
5	689.565	5.51	26.57	32.08	-13.92	46.00	Peak
6	* 846.571	4.96	28.54	33.49	-12.51	46.00	Peak

Note:

1. " *", means this data is the worst emission level.
2. C.F (Correction Factor) = Antenna Factor (dB/m) + Cable Loss (dB).
3. Measurement(dBuV/m) = Reading(dBuV) + C.F (Correction Factor).
4. The emission levels of other frequencies are very lower than the limit and not show in test report.
5. QP measurement was not performed when peak measure level was lower than the QP limit.

EUT	ACCESS POINT (APEX0584)	Date of Test	2021-11-03
Factor	VULB 9162 (30MHz~8GHz) + 6dB Attenuator_2020	Temp. / Humidity	25.1°C /43%
Polarity	Vertical	Site / Test Engineer	AC1 / Jay
Test Mode	Transmit by Zigbee at Channel 2405MHz	Test Voltage	By PoE

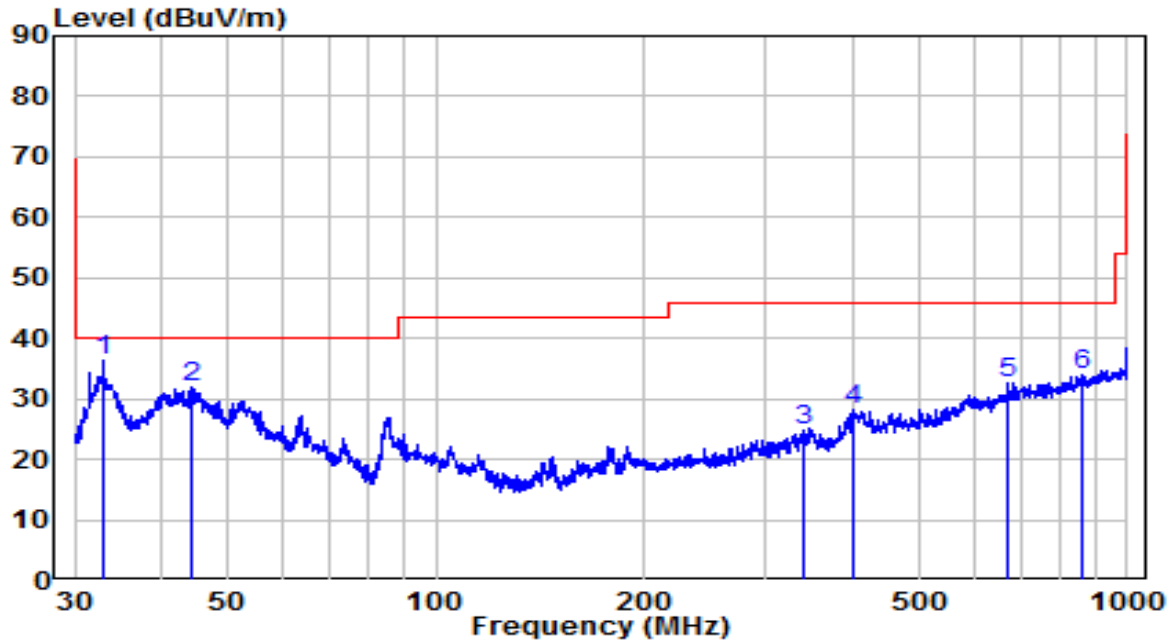

No	Frequency (MHz)	Reading (dBUV)	C.F (dB/m)	Measurement (dBUV/m)	Margin (dB)	Limit (dBUV/m)	Remark (QP/PK/AV)	
1	*	32.979	18.00	18.44	36.44	-3.56	40.00	Peak
2		44.353	10.70	21.11	31.81	-8.19	40.00	Peak
3		338.994	3.85	21.05	24.89	-21.11	46.00	Peak
4		402.544	6.13	22.14	28.26	-17.74	46.00	Peak
5		672.845	6.37	26.37	32.75	-13.25	46.00	Peak
6		863.056	5.30	28.65	33.95	-12.05	46.00	Peak

Note:

1. " *", means this data is the worst emission level.
2. C.F (Correction Factor) = Antenna Factor (dB/m) + Cable Loss (dB).
3. Measurement(dBUV/m) = Reading(dBUV) + C.F (Correction Factor).
4. The emission levels of other frequencies are very lower than the limit and not show in test report.
5. QP measurement was not performed when peak measure level was lower than the QP limit.

The Worst Case Result of Radiated Spurious Emission above 18GHz:
APEX0584

EUT	ASSESS POINT	Date of Test	2022-01-06
Factor	BBHA 9170 (15GHz~40GHz)_2021	Temp. / Humidity	25.1°C/43%
Polarity	Horizontal	Site / Test Engineer	AC1 / Jay Chu
Test Mode	Transmit by Zigbee at Channel 2405MHz	Test Voltage	120V/60Hz

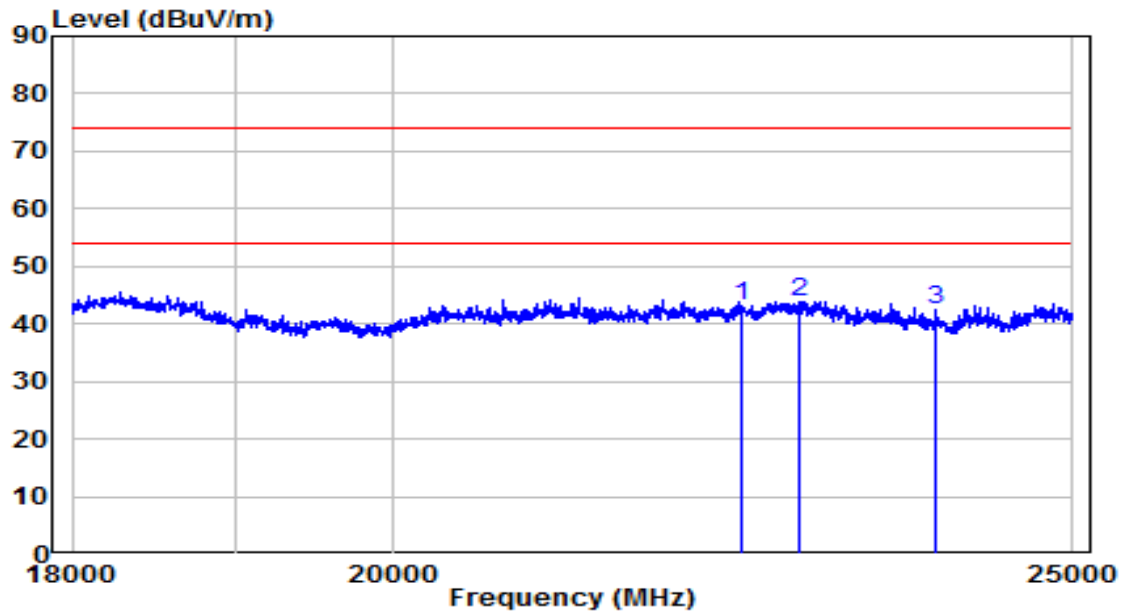

No	Frequency (MHz)	Reading (dB μ V)	C.F (dB/m)	Measurement (dB μ V/m)	Margin (dB)	Limit (dB μ V/m)	Remark (QP/PK/AV)
1	22431.000	39.53	3.74	43.27	-30.73	74.00	Peak
2	* 22858.000	39.95	4.01	43.96	-30.04	74.00	Peak
3	23908.000	38.25	4.04	42.29	-31.71	74.00	Peak

Note:

- "*", means this data is the worst emission level.
- C.F (Correction Factor) = Antenna Factor (dB/m) + Cable Loss (dB) – Pre-amplifier(dB).
- Measurement(dB μ V/m) = Reading(dB μ V) + C.F (Correction Factor).

EUT	ASSESS POINT	Date of Test	2022-01-06
Factor	BBHA 9170 (15GHz~40GHz)_2021	Temp. / Humidity	25.1°C/43%
Polarity	Vertical	Site / Test Engineer	AC1 / Jay Chu
Test Mode	Transmit by Zigbee at Channel 2405MHz	Test Voltage	120V/60Hz

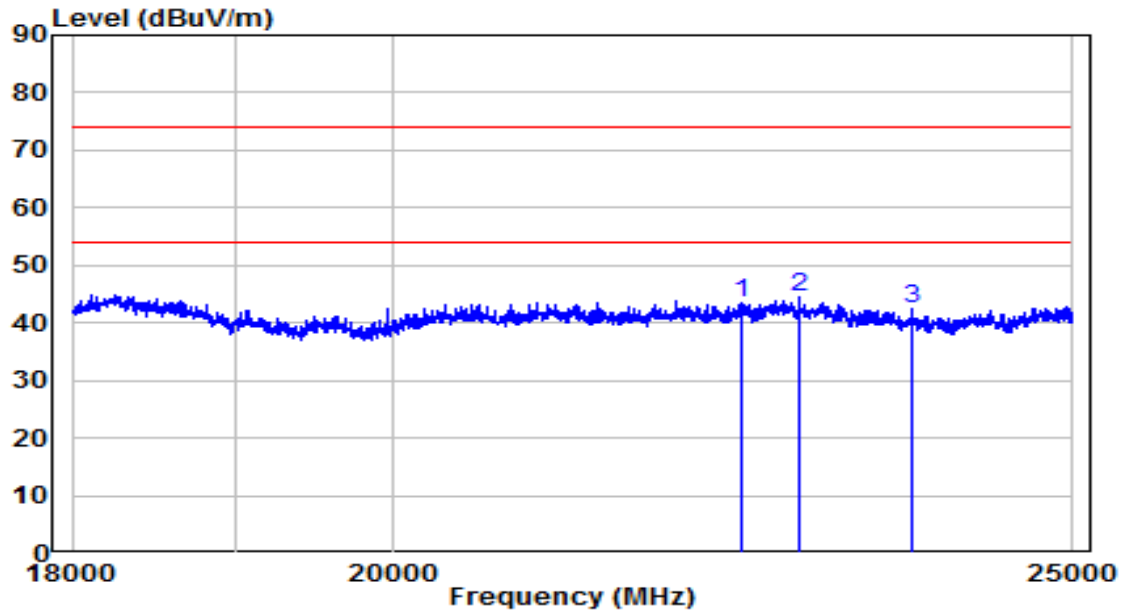

No	Frequency (MHz)	Reading (dB μ V)	C.F (dB/m)	Measurement (dB μ V/m)	Margin (dB)	Limit (dB μ V/m)	Remark (QP/PK/AV)
1	22431.000	39.63	3.74	43.37	-30.63	74.00	Peak
2	* 22851.000	40.45	4.01	44.46	-29.54	74.00	Peak
3	23712.000	38.17	4.12	42.29	-31.71	74.00	Peak

Note:

1. " *", means this data is the worst emission level.
2. C.F (Correction Factor) = Antenna Factor (dB/m) + Cable Loss (dB) – Preamplifier(dB).
3. Measurement(dB μ V/m) = Reading(dB μ V) + C.F (Correction Factor).

APEX0587

EUT	ACCESS POINT	Date of Test	2022-01-06
Factor	BBHA 9170 (15GHz~40GHz)_2021	Temp. / Humidity	25.1°C/43%
Polarity	Horizontal	Site / Test Engineer	AC1 / Jay Chu
Test Mode	Transmit by Zigbee at Channel 2405MHz	Test Voltage	120V/60Hz

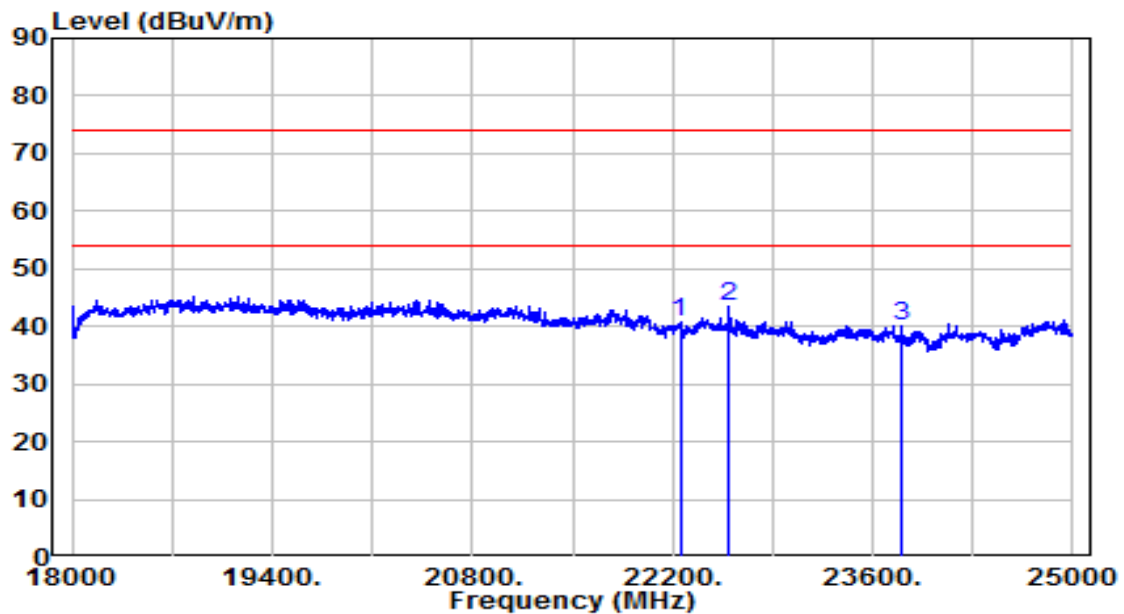

No	Frequency (MHz)	Reading (dB μ V)	C.F (dB/m)	Measurement (dB μ V/m)	Margin (dB)	Limit (dB μ V/m)	Remark (QP/PK/AV)
1	22252.500	37.24	3.60	40.84	-33.16	74.00	Peak
2	* 22599.000	39.57	3.86	43.43	-30.57	74.00	Peak
3	23799.500	36.16	4.08	40.24	-33.76	74.00	Peak

Note:

- " *", means this data is the worst emission level.
- C.F (Correction Factor) = Antenna Factor (dB/m) + Cable Loss (dB) – Preamplifier(dB).
- Measurement(dB μ V/m) = Reading(dB μ V) + C.F (Correction Factor).

EUT	ACCESS POINT	Date of Test	2022-01-06
Factor	BBHA 9170 (15GHz~40GHz)_2021	Temp. / Humidity	25.1°C/43%
Polarity	Vertical	Site / Test Engineer	AC1 / Jay Chu
Test Mode	Transmit by Zigbee at Channel 2405MHz	Test Voltage	120V/60Hz

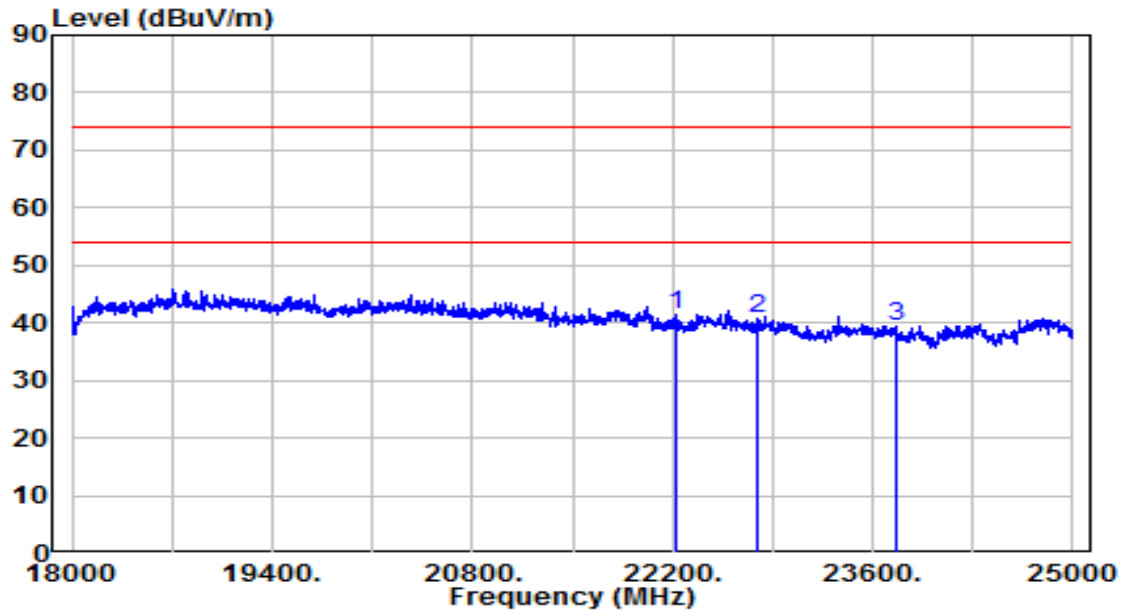

No	Frequency (MHz)	Reading (dB μ V)	C.F (dB/m)	Measurement (dB μ V/m)	Margin (dB)	Limit (dB μ V/m)	Remark (QP/PK/AV)	
1	*	22228.000	37.82	3.58	41.40	-32.60	74.00	Peak
2		22784.500	36.70	3.97	40.67	-33.33	74.00	Peak
3		23757.500	35.26	4.10	39.35	-34.65	74.00	Peak

Note:

1. " *", means this data is the worst emission level.
2. C.F (Correction Factor) = Antenna Factor (dB/m) + Cable Loss (dB) – Preamplifier(dB).
3. Measurement(dB μ V/m) = Reading(dB μ V) + C.F (Correction Factor).

APEX0585

EUT	ACCESS POINT	Date of Test	2022-01-06
Factor	BBHA 9170 (15GHz~40GHz)_2021	Temp. / Humidity	25.1°C/43%
Polarity	Horizontal	Site / Test Engineer	AC2 / Bob Zhang
Test Mode	Transmit by Zigbee at Channel 2405MHz	Test Voltage	120V/60Hz

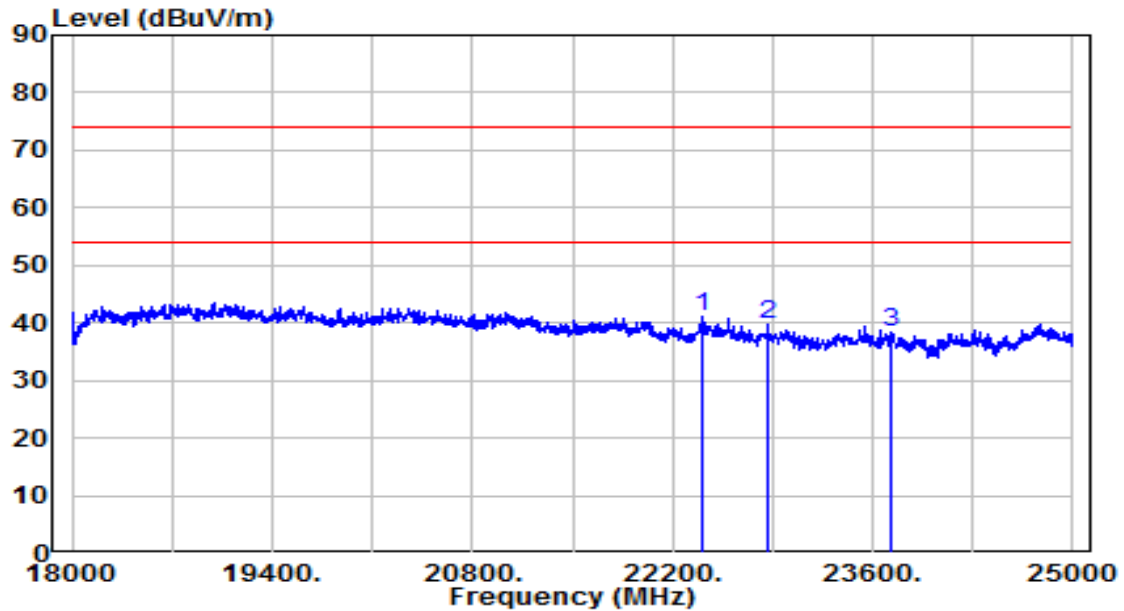

No	Frequency (MHz)	Reading (dB μ V)	C.F (dB/m)	Measurement (dB μ V/m)	Margin (dB)	Limit (dB μ V/m)	Remark (QP/PK/AV)	
1	*	22413.500	37.21	3.73	40.94	-33.06	74.00	Peak
2		22868.500	35.81	4.02	39.83	-34.17	74.00	Peak
3		23726.000	34.27	4.11	38.38	-35.62	74.00	Peak

Note:

1. " *", means this data is the worst emission level.
2. C.F (Correction Factor) = Antenna Factor (dB/m) + Cable Loss (dB) – Preamplifier(dB).
3. Measurement(dB μ V/m) = Reading(dB μ V) + C.F (Correction Factor).

EUT	ACCESS POINT	Date of Test	2022-01-06
Factor	BBHA 9170 (15GHz~40GHz)_2021	Temp. / Humidity	25.1°C/43%
Polarity	Vertical	Site / Test Engineer	AC2 / Bob Zhang
Test Mode	Transmit by Zigbee at Channel 2405MHz	Test Voltage	120V/60Hz

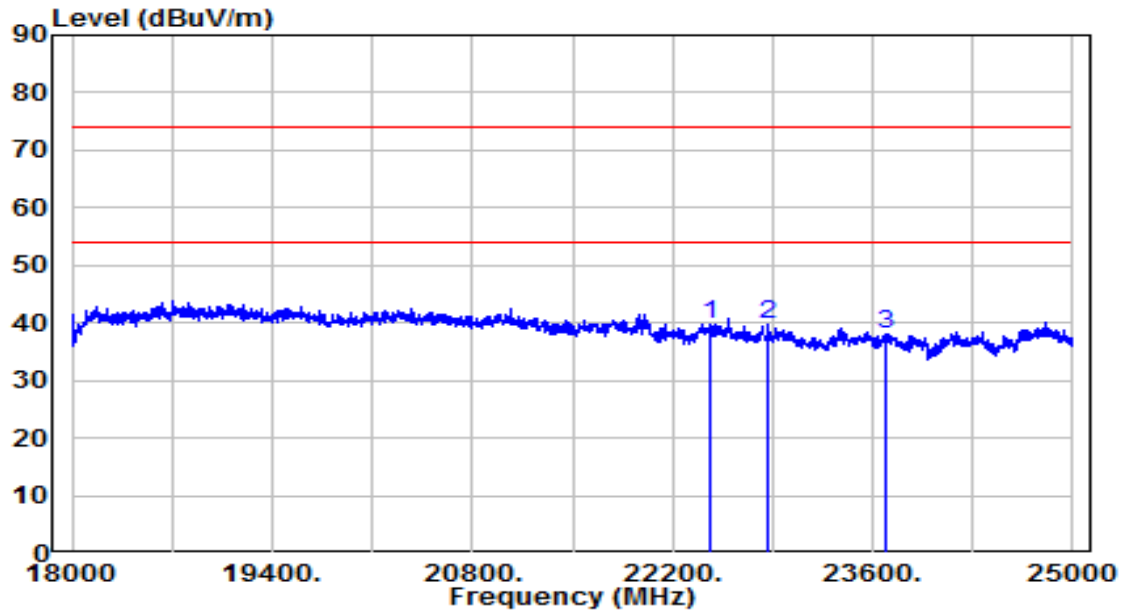

No	Frequency (MHz)	Reading (dB μ V)	C.F (dB/m)	Measurement (dB μ V/m)	Margin (dB)	Limit (dB μ V/m)	Remark (QP/PK/AV)
1	*	36.13	3.76	39.89	-34.11	74.00	Peak
2		35.65	4.02	39.67	-34.33	74.00	Peak
3		33.84	4.13	37.96	-36.04	74.00	Peak

Note:

1. " *", means this data is the worst emission level.
2. C.F (Correction Factor) = Antenna Factor (dB/m) + Cable Loss (dB) – Preamplifier(dB).
3. Measurement(dB μ V/m) = Reading(dB μ V) + C.F (Correction Factor).

7.7. Radiated Restricted Band Edge Measurement

7.7.1. Test Limit

For 15.205 requirement:

Radiated emissions which fall in the restricted bands, as defined in Section 15.205(a) of FCC part 15, must also comply with the radiated emission limits specified in Section 15.209(a).

Frequency (MHz)	Frequency (MHz)	Frequency (MHz)	Frequency (GHz)
0.090 - 0.110	16.42-16.423	399.9 - 410	4.5-5.15
¹ 0.495 - 0.505	16.69475-16.69525	608 - 614	5.35-5.46
2.1735-2.1905	16.80425-16.80475	960 - 1240	7.25-7.75
4.125-4.128	25.5 -25.67	1300 - 1427	8.25 - 8.5
4.17725-4.17775	37.5-38.25	1435-1626.5	9.0-9.2
4.20725-4.20775	73-74.6	1645.5-1646.5	9.3-9.5
6.215-6.218	74.8-75.2	1660 - 1710	10.6-12.7
6.26775-6.26825	108-121.94	1718.8-1722.2	13.25-13.4
6.31175-6.31225	123 - 138	2200 - 2300	14.47-14.5
8.291-8.294	149.9-150.05	2310 - 2390	15.35-16.2
8.362-8.366	156.52475-156.525	2483.5 - 2500	17.7-21.4
8.37625-8.38675	156.7-156.9	2690 - 2900	22.01-23.12
8.41425-8.41475	162.0125-167.17	3260 - 3267	23.6-24.0
12.29-12.293	167.72-173.2	3332 - 3339	31.2-31.8
12.51975-12.52025	240 - 285	3345.8 - 3358	36.43-36.5
12.57675-12.57725	322-335.4	3600 - 4400	(²)
13.36-13.41	--	--	--

All out of band emissions appearing in a restricted band as specified in Section 15.205 of the Title 47CFR must not exceed the limits shown in Table per Section 15.209.

FCC Part 15 Subpart C Paragraph 15.209		
Frequency [MHz]	Field Strength [uV/m]	Measured Distance [Meters]
0.009 - 0.490	2400/F (kHz)	300
0.490 - 1.705	24000/F (kHz)	30
1.705 - 30	30	30
30 - 88	100	3
88 - 216	150	3
216 - 960	200	3
Above 960	500	3

7.7.2. Test Procedure Used

ANSI C63.10-2013 Section 6.3 (General Requirements)

ANSI C63.10-2013 Section 6.6 (Standard test method above 1GHz)

ANSI C63.10-2013 Section 11.13

7.7.3. Test Setting

Peak Field Strength Measurements

1. Analyzer center frequency was set to the frequency of the radiated spurious emission of interest
2. RBW = 1MHz
3. VBW = 3MHz
4. Detector = peak
5. Sweep time = auto couple
6. Trace mode = max hold
7. Trace was allowed to stabilize

Average Field Strength Measurements

1. Average Measurement Level = Peak Measurement Level - $20 * \text{Log}(\text{Duty Cycle}) = -20$
2. Duty Cycle = 10%

7.7.4. Test Setup

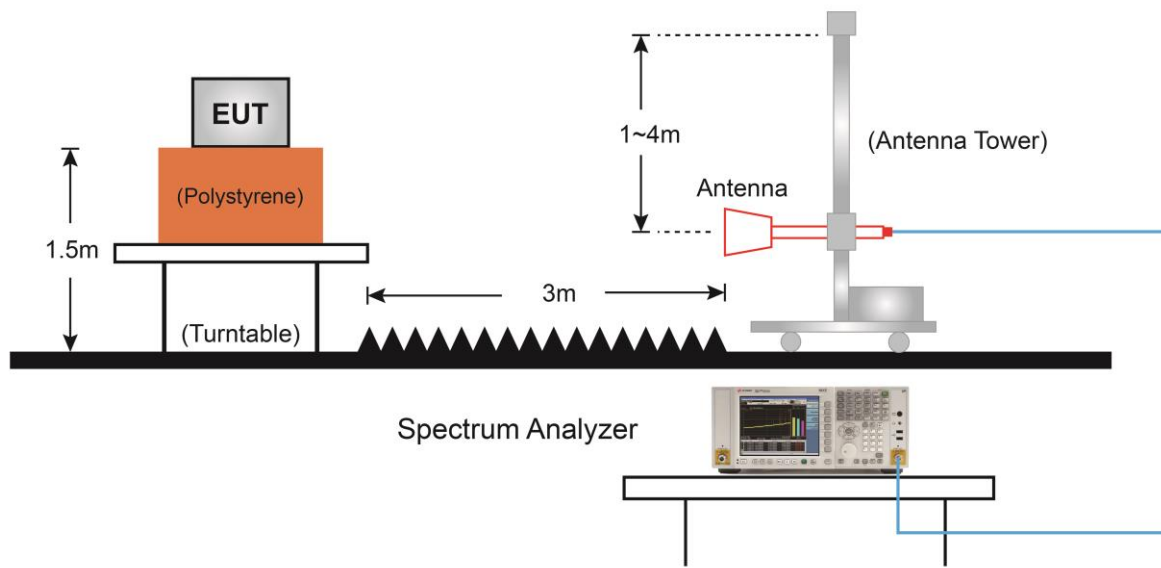

7.7.5. Test Result

APEX0585 Filter 4#

EUT	ASSESS POINT	Date of Test	2021-11-03
Factor	BBHA 9120D (1GHz~18GHz)_2021	Temp. / Humidity	26.2°C/48.6%
Polarity	Horizontal	Site / Test Engineer	AC1 / Jay
Test Mode	Transmit by Zigbee at Channel 2405MHz	Test Voltage	By PoE

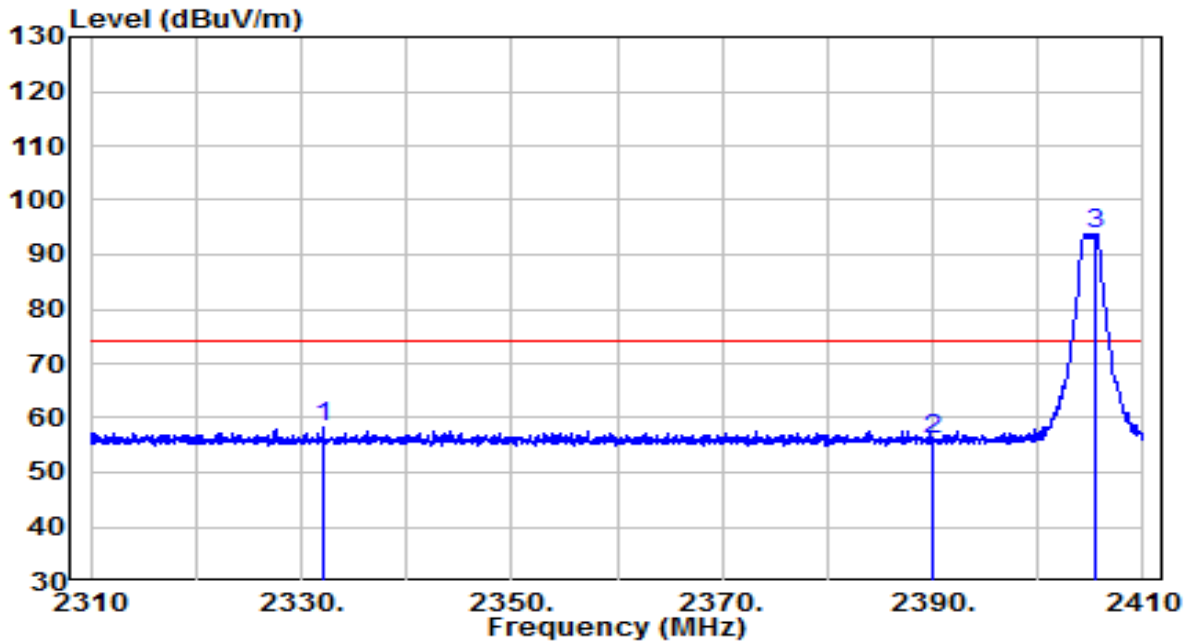

No	Frequency (MHz)	Reading (dBuV)	C.F (dB/m)	Measurement (dBuV/m)	Margin (dB)	Limit (dBuV/m)	Remark (QP/PK/AV)
1	2332.150	26.17	31.98	58.15	-15.85	74.00	Peak
1	2332.150	26.17	31.98	38.15	-15.85	54.00	Average
2	2390.000	23.82	32.22	56.04	-17.96	74.00	Peak
2	2390.000	23.82	32.22	36.04	-17.96	54.00	Average
3	* 2405.450	61.65	32.28	93.94	N/A	N/A	Peak
3	* 2405.450	61.65	32.28	73.94	N/A	N/A	Average

Note:

1. " *", means this data is the worst emission level.
2. C.F (Correction Factor) = Antenna Factor (dB/m)+ Cable Loss (dB)
3. Measurement(dBuV/m) = Reading(dBuV) + C.F (Correction Factor).
4. The emission levels of other frequencies are very lower than the limit and not show in test report.
5. Average Measure Level = Peak Measure Level + Duty Cycle Factor, Duty Cycle Factor= -20dB.

EUT	ASSESS POINT	Date of Test	2021-11-03
Factor	BBHA 9120D (1GHz~18GHz)_2021	Temp. / Humidity	26.2°C/48.6%
Polarity	Vertical	Site / Test Engineer	AC1 / Jay
Test Mode	Transmit by Zigbee at Channel 2405MHz	Test Voltage	By PoE

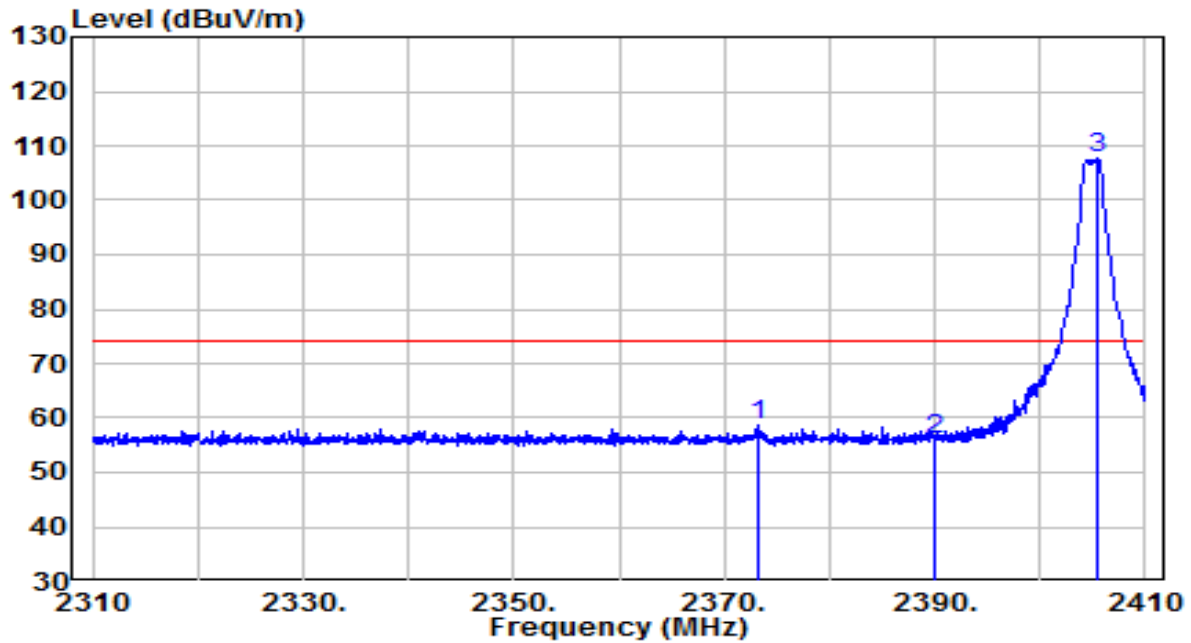

No	Frequency (MHz)	Reading (dBuV)	C.F (dB/m)	Measurement (dBuV/m)	Margin (dB)	Limit (dBuV/m)	Remark (QP/PK/AV)
1	2373.300	26.66	32.15	58.81	-15.19	74.00	Peak
1	2373.300	26.66	32.15	38.81	-15.19	54.00	Average
2	2390.000	23.68	32.22	55.90	-18.10	74.00	Peak
2	2390.000	23.68	32.22	35.90	-18.10	54.00	Average
3	* 2405.500	75.31	32.28	107.59	N/A	N/A	Peak
3	* 2405.500	75.31	32.28	87.59	N/A	N/A	Average

Note:

1. " *", means this data is the worst emission level.
2. C.F (Correction Factor) = Antenna Factor (dB/m)+ Cable Loss (dB)
3. Measurement(dBuV/m) = Reading(dBuV) + C.F (Correction Factor).
4. The emission levels of other frequencies are very lower than the limit and not show in test report.
5. Average Measure Level = Peak Measure Level + Duty Cycle Factor, Duty Cycle Factor= -20dB.

EUT	ASSESS POINT	Date of Test	2021-11-03
Factor	BBHA 9120D (1GHz~18GHz)_2021	Temp. / Humidity	26.2°C/48.6%
Polarity	Horizontal	Site / Test Engineer	AC1 / Jay
Test Mode	Transmit by Zigbee at Channel 2480MHz	Test Voltage	By PoE

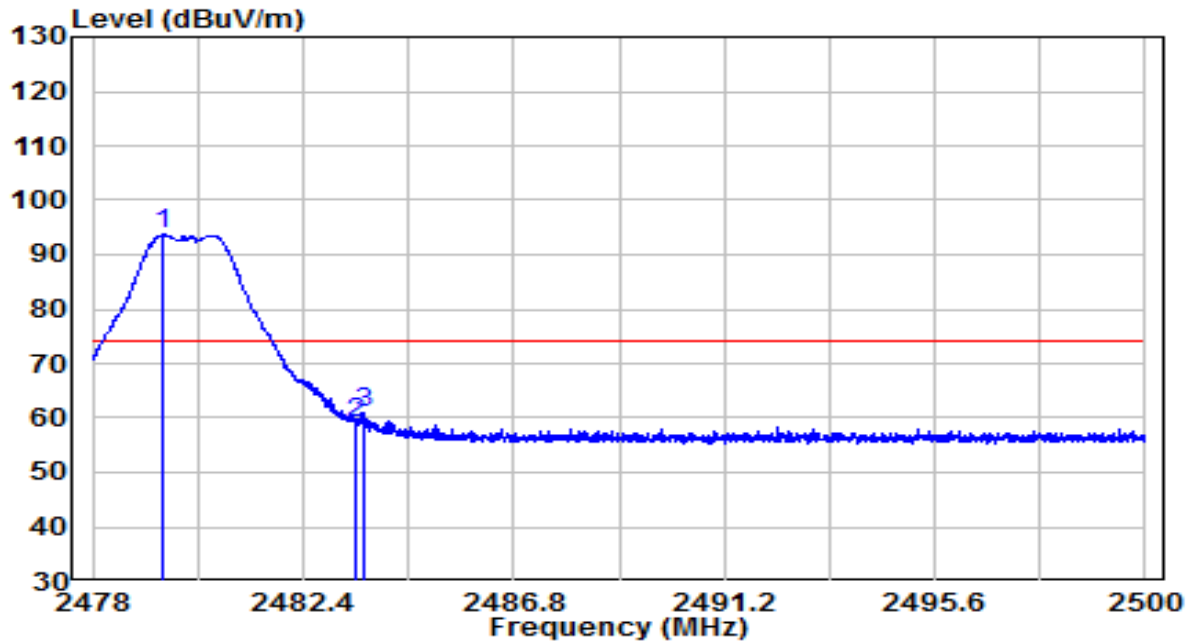

No	Frequency (MHz)	Reading (dBuV)	C.F (dB/m)	Measurement (dBuV/m)	Margin (dB)	Limit (dBuV/m)	Remark (QP/PK/AV)	
1	*	2479.474	61.07	32.59	93.66	N/A	N/A	Peak
1	*	2479.474	61.07	32.59	73.66	N/A	N/A	Average
2		2483.500	26.27	32.61	58.88	-15.12	74.00	Peak
2		2483.500	26.27	32.61	38.88	-15.12	54.00	Average
3		2483.643	28.42	32.61	61.03	-12.97	74.00	Peak
3		2483.643	28.42	32.61	41.03	-12.97	54.00	Average

Note:

1. " *", means this data is the worst emission level.
2. C.F (Correction Factor) = Antenna Factor (dB/m)+ Cable Loss (dB)
3. Measurement(dBuV/m) = Reading(dBuV) + C.F (Correction Factor).
4. The emission levels of other frequencies are very lower than the limit and not show in test report.
5. Average Measure Level = Peak Measure Level + Duty Cycle Factor, Duty Cycle Factor= -20dB.

EUT	ASSESS POINT	Date of Test	2021-11-03
Factor	BBHA 9120D (1GHz~18GHz)_2021	Temp. / Humidity	26.2°C/48.6%
Polarity	Vertical	Site / Test Engineer	AC1 / Jay
Test Mode	Transmit by Zigbee at Channel 2480MHz	Test Voltage	By PoE

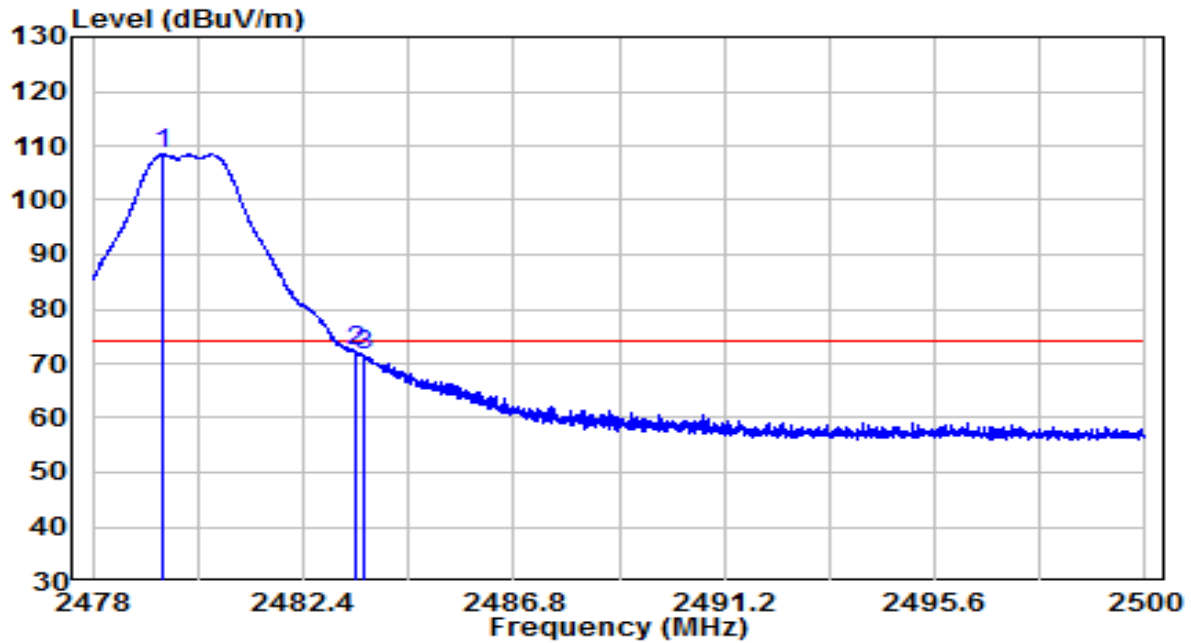

No	Frequency (MHz)	Reading (dBUV)	C.F (dB/m)	Measurement (dBUV/m)	Margin (dB)	Limit (dBUV/m)	Remark (QP/PK/AV)	
1	*	2479.463	75.77	32.59	108.36	N/A	N/A	Peak
1	*	2479.463	75.77	32.59	88.36	N/A	N/A	Average
2		2483.500	39.53	32.61	72.14	-1.86	74.00	Peak
2		2483.500	39.53	32.61	52.14	-1.86	54.00	Average
3		2483.665	39.08	32.61	71.70	-2.30	74.00	Peak
3		2483.665	39.08	32.61	51.70	-2.30	54.00	Average

Note:

- "*", means this data is the worst emission level.
- C.F (Correction Factor) = Antenna Factor (dB/m)+ Cable Loss (dB)
- Measurement(dBUV/m) = Reading(dBUV) + C.F (Correction Factor).
- The emission levels of other frequencies are very lower than the limit and not show in test report.
- Average Measure Level = Peak Measure Level + Duty Cycle Factor, Duty Cycle Factor= -20dB.

APEX0585 Filter 5#

EUT	ASSESS POINT	Date of Test	2021-11-03
Factor	BBHA 9120D (1GHz~18GHz)_2021	Temp. / Humidity	26.2°C/48.6%
Polarity	Horizontal	Site / Test Engineer	AC1 / Jay
Test Mode	Transmit by Zigbee at Channel 2405MHz	Test Voltage	By PoE

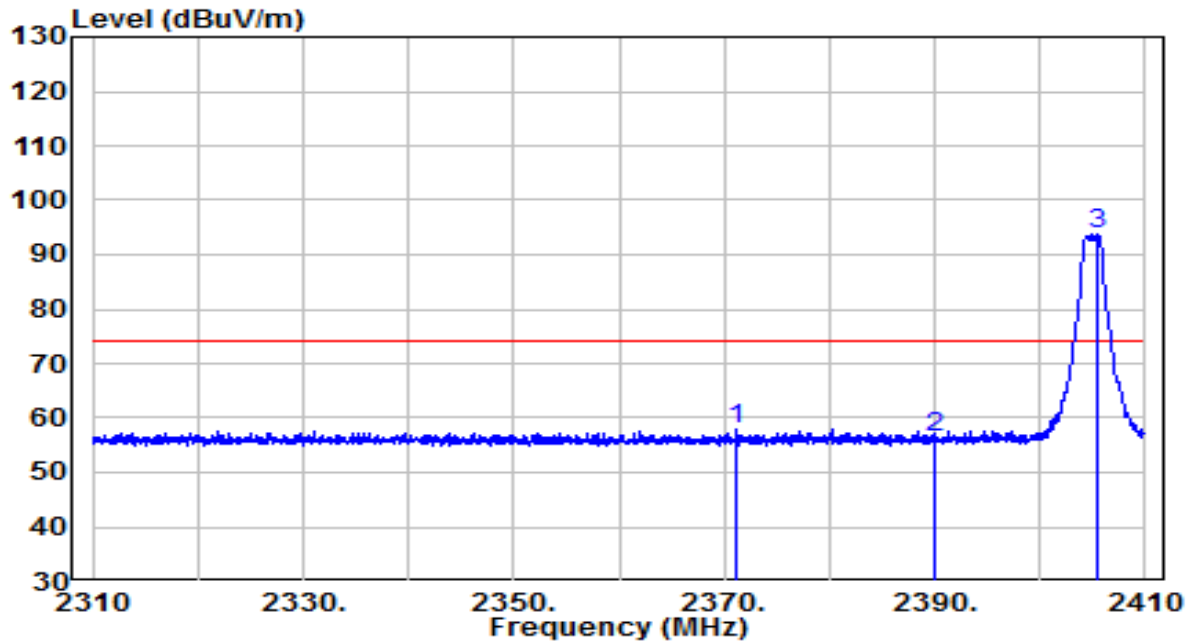

No	Frequency (MHz)	Reading (dBuV)	C.F (dB/m)	Measurement (dBuV/m)	Margin (dB)	Limit (dBuV/m)	Remark (QP/PK/AV)
1	2371.150	25.67	32.14	57.81	-16.19	74.00	Peak
1	2371.150	25.67	32.14	37.81	-16.19	54.00	Average
2	2390.000	24.08	32.22	56.30	-17.70	74.00	Peak
2	2390.000	24.08	32.22	36.30	-17.70	54.00	Average
3	* 2405.500	61.42	32.28	93.70	N/A	N/A	Peak
3	* 2405.500	61.42	32.28	73.70	N/A	N/A	Average

Note:

1. " *", means this data is the worst emission level.
2. C.F (Correction Factor) = Antenna Factor (dB/m)+ Cable Loss (dB)
3. Measurement(dBuV/m) = Reading(dBuV) + C.F (Correction Factor).
4. The emission levels of other frequencies are very lower than the limit and not show in test report.
5. Average Measure Level = Peak Measure Level + Duty Cycle Factor, Duty Cycle Factor= -20dB.

EUT	ASSESS POINT	Date of Test	2021-11-03
Factor	BBHA 9120D (1GHz~18GHz)_2021	Temp. / Humidity	26.2°C/48.6%
Polarity	Vertical	Site / Test Engineer	AC1 / Jay
Test Mode	Transmit by Zigbee at Channel 2405MHz	Test Voltage	By PoE

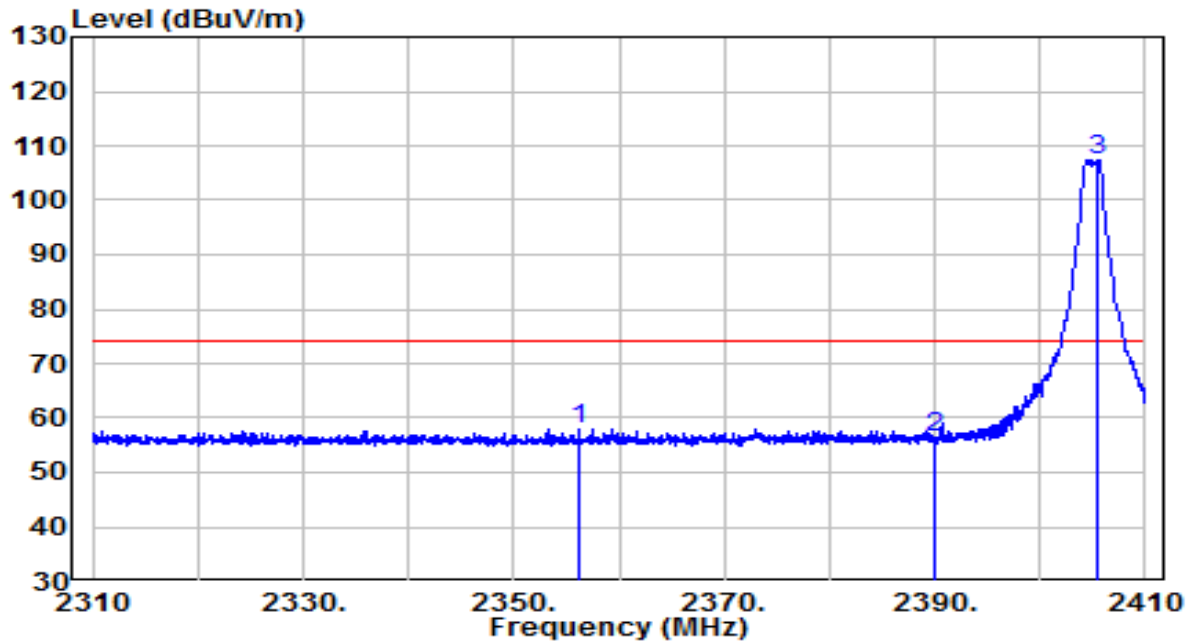

No	Frequency (MHz)	Reading (dBuV)	C.F (dB/m)	Measurement (dBuV/m)	Margin (dB)	Limit (dBuV/m)	Remark (QP/PK/AV)
1	2356.250	25.99	32.08	58.06	-15.94	74.00	Peak
1	2356.250	25.99	32.08	38.06	-15.94	54.00	Average
2	2390.000	24.19	32.22	56.41	-17.59	74.00	Peak
2	2390.000	24.19	32.22	36.41	-17.59	54.00	Average
3 *	2405.500	75.12	32.28	107.40	N/A	N/A	Peak
3 *	2405.500	75.12	32.28	87.40	N/A	N/A	Average

Note:

1. " *", means this data is the worst emission level.
2. C.F (Correction Factor) = Antenna Factor (dB/m)+ Cable Loss (dB)
3. Measurement(dBuV/m) = Reading(dBuV) + C.F (Correction Factor).
4. The emission levels of other frequencies are very lower than the limit and not show in test report.
5. Average Measure Level = Peak Measure Level + Duty Cycle Factor, Duty Cycle Factor= -20dB.

APEX0585 Filter 6#

EUT	ASSESS POINT	Date of Test	2021-11-03
Factor	BBHA 9120D (1GHz~18GHz)_2021	Temp. / Humidity	26.2°C/48.6%
Polarity	Horizontal	Site / Test Engineer	AC1 / Jay
Test Mode	Transmit by Zigbee at Channel 2480MHz	Test Voltage	By PoE

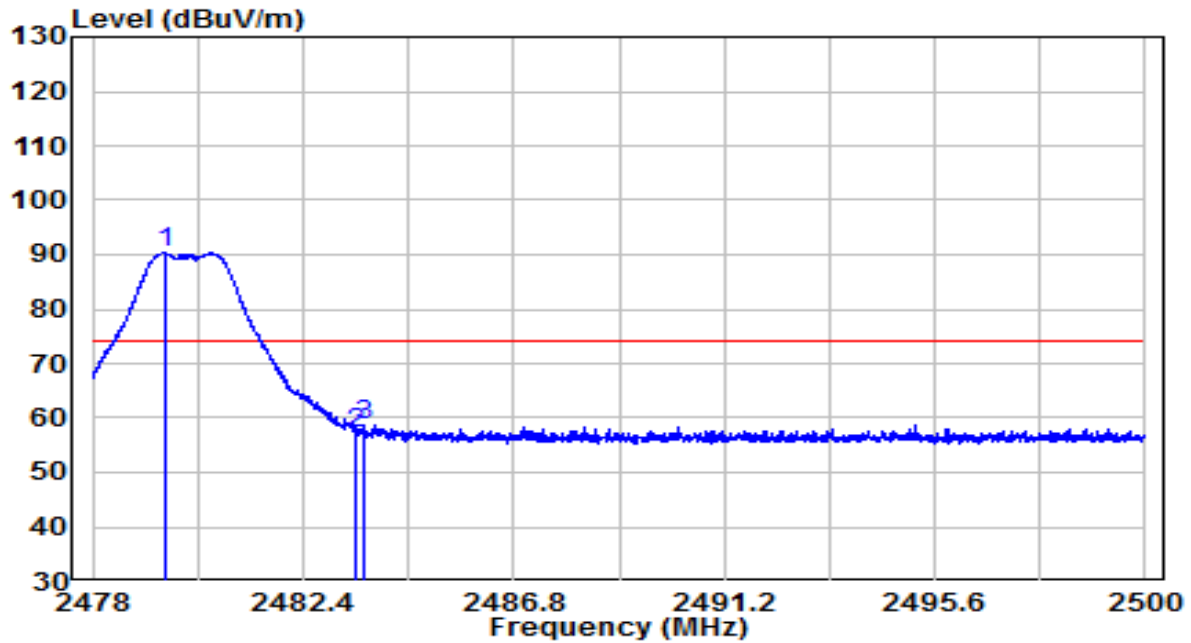

No	Frequency (MHz)	Reading (dBuV)	C.F (dB/m)	Measurement (dBuV/m)	Margin (dB)	Limit (dBuV/m)	Remark (QP/PK/AV)	
1	*	2479.496	57.67	32.59	90.26	N/A	N/A	Peak
1	*	2479.496	57.67	32.59	70.26	N/A	N/A	Average
2		2483.500	24.75	32.61	57.36	-16.64	74.00	Peak
2		2483.500	24.75	32.61	37.36	-16.64	54.00	Average
3		2483.676	26.11	32.61	58.73	-15.27	74.00	Peak
3		2483.676	26.11	32.61	38.73	-15.27	54.00	Average

Note:

1. " *", means this data is the worst emission level.
2. C.F (Correction Factor) = Antenna Factor (dB/m)+ Cable Loss (dB)
3. Measurement(dBuV/m) = Reading(dBuV) + C.F (Correction Factor).
4. The emission levels of other frequencies are very lower than the limit and not show in test report.
5. Average Measure Level = Peak Measure Level + Duty Cycle Factor, Duty Cycle Factor= -20dB.

EUT	ASSESS POINT	Date of Test	2021-11-03
Factor	BBHA 9120D (1GHz~18GHz)_2021	Temp. / Humidity	26.2°C/48.6%
Polarity	Vertical	Site / Test Engineer	AC1 / Jay
Test Mode	Transmit by Zigbee at Channel 2480MHz	Test Voltage	By PoE

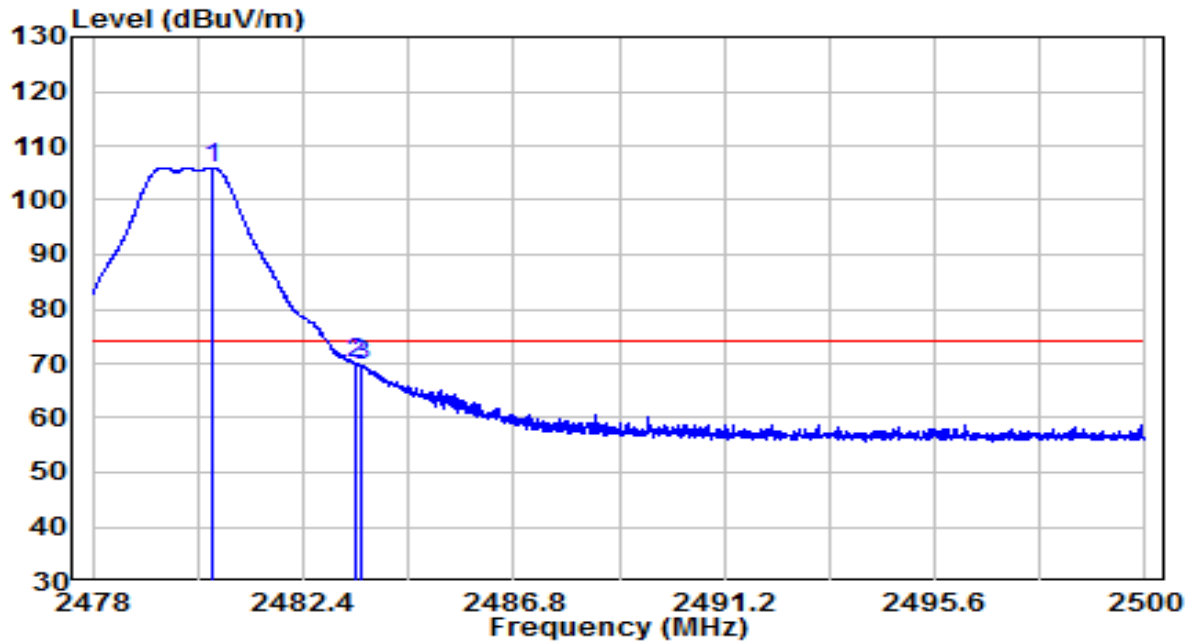

No	Frequency (MHz)	Reading (dBuV)	C.F (dB/m)	Measurement (dBuV/m)	Margin (dB)	Limit (dBuV/m)	Remark (QP/PK/AV)	
1	*	2480.508	73.42	32.60	106.01	N/A	N/A	Peak
1	*	2480.508	73.42	32.60	86.01	N/A	N/A	Average
2		2483.500	37.32	32.61	69.93	-4.07	74.00	Peak
2		2483.500	37.32	32.61	49.93	-4.07	54.00	Average
3		2483.621	37.20	32.61	69.81	-4.19	74.00	Peak
3		2483.621	37.20	32.61	49.81	-4.19	54.00	Average

Note:

- "*", means this data is the worst emission level.
- C.F (Correction Factor) = Antenna Factor (dB/m)+ Cable Loss (dB)
- Measurement(dBuV/m) = Reading(dBuV) + C.F (Correction Factor).
- The emission levels of other frequencies are very lower than the limit and not show in test report.
- Average Measure Level = Peak Measure Level + Duty Cycle Factor, Duty Cycle Factor= -20dB.

APEX0587 Filter 4#

EUT	ASSESS POINT	Date of Test	2021-11-03
Factor	BBHA 9120D (1GHz~18GHz)_2021	Temp. / Humidity	26°C/48%
Polarity	Horizontal	Site / Test Engineer	AC1 / Jay
Test Mode	Transmit by Zigbee at Channel 2405MHz	Test Voltage	By PoE

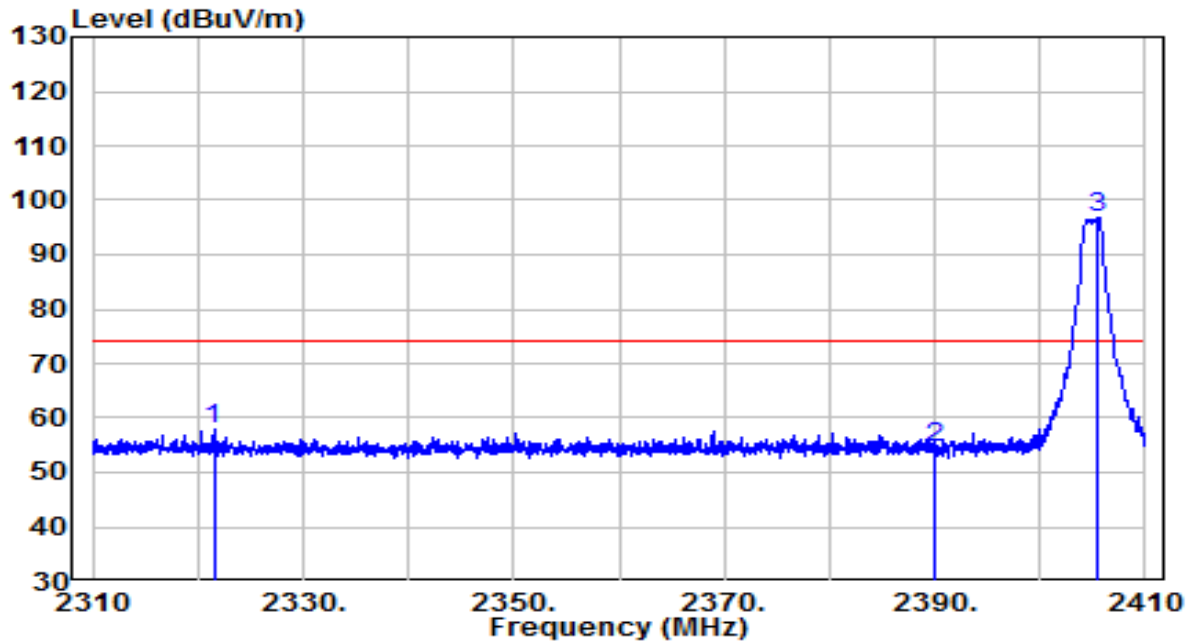

No	Frequency (MHz)	Reading (dBuV)	C.F (dB/m)	Measurement (dBuV/m)	Margin (dB)	Limit (dBuV/m)	Remark (QP/PK/AV)
1	2321.500	26.05	31.93	57.98	-16.02	74.00	Peak
1	2321.500	26.05	31.93	37.98	-16.02	54.00	Average
2	2390.000	22.39	32.22	54.60	-19.40	74.00	Peak
2	2390.000	22.39	32.22	34.60	-19.40	54.00	Average
3	* 2405.500	64.45	32.28	96.74	N/A	N/A	Peak
3	* 2405.500	64.45	32.28	76.74	N/A	N/A	Average

Note:

1. " *", means this data is the worst emission level.
2. C.F (Correction Factor) = Antenna Factor (dB/m)+ Cable Loss (dB)
3. Measurement(dBuV/m) = Reading(dBuV) + C.F (Correction Factor).
4. The emission levels of other frequencies are very lower than the limit and not show in test report.
5. Average Measure Level = Peak Measure Level + Duty Cycle Factor, Duty Cycle Factor= -20dB.

EUT	ASSESS POINT	Date of Test	2021-11-03
Factor	BBHA 9120D (1GHz~18GHz)_2021	Temp. / Humidity	26°C/48%
Polarity	Vertical	Site / Test Engineer	AC1 / Jay
Test Mode	Transmit by Zigbee at Channel 2405MHz	Test Voltage	By PoE

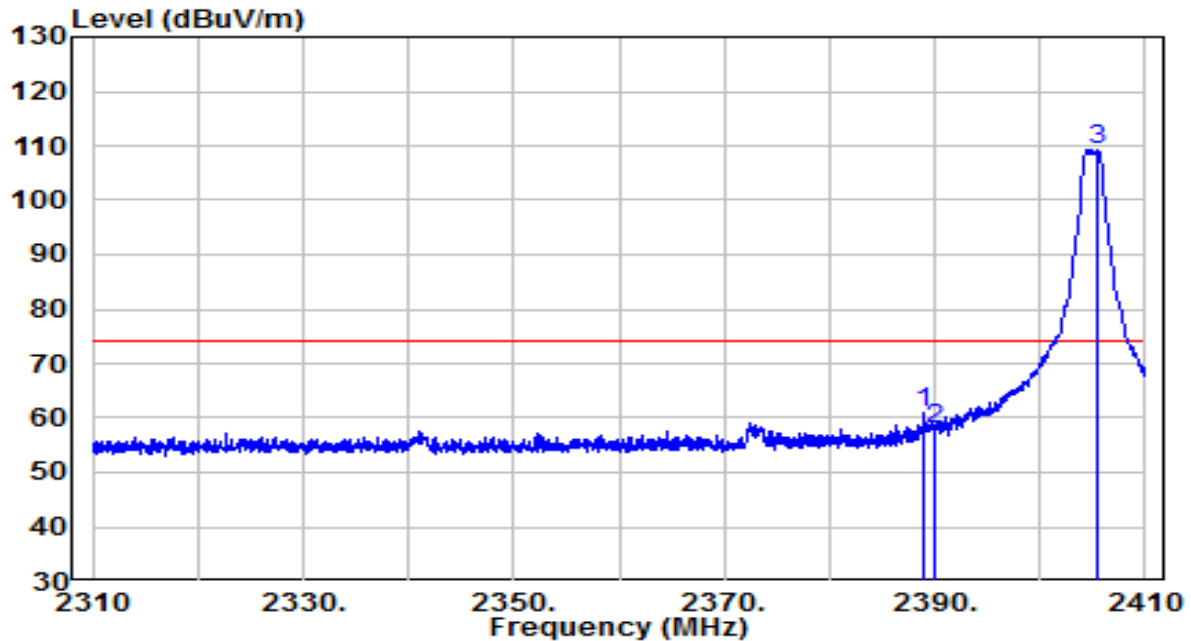

No	Frequency (MHz)	Reading (dBuV)	C.F (dB/m)	Measurement (dBuV/m)	Margin (dB)	Limit (dBuV/m)	Remark (QP/PK/AV)
1	2389.000	28.83	32.21	61.04	-12.96	74.00	Peak
1	2389.000	28.83	32.21	41.04	-12.96	54.00	Average
2	2390.000	25.79	32.22	58.01	-15.99	74.00	Peak
2	2390.000	25.79	32.22	38.01	-15.99	54.00	Average
3	* 2405.500	76.90	32.28	109.18	N/A	N/A	Peak
3	* 2405.500	76.90	32.28	89.18	N/A	N/A	Average

Note:

1. " *", means this data is the worst emission level.
2. C.F (Correction Factor) = Antenna Factor (dB/m)+ Cable Loss (dB)
3. Measurement(dBuV/m) = Reading(dBuV) + C.F (Correction Factor).
4. The emission levels of other frequencies are very lower than the limit and not show in test report.
5. Average Measure Level = Peak Measure Level + Duty Cycle Factor, Duty Cycle Factor= -20dB.

EUT	ASSESS POINT	Date of Test	2021-11-03
Factor	BBHA 9120D (1GHz~18GHz)_2021	Temp. / Humidity	26°C/48%
Polarity	Horizontal	Site / Test Engineer	AC1 / Jay
Test Mode	Transmit by Zigbee at Channel 2480MHz	Test Voltage	By PoE

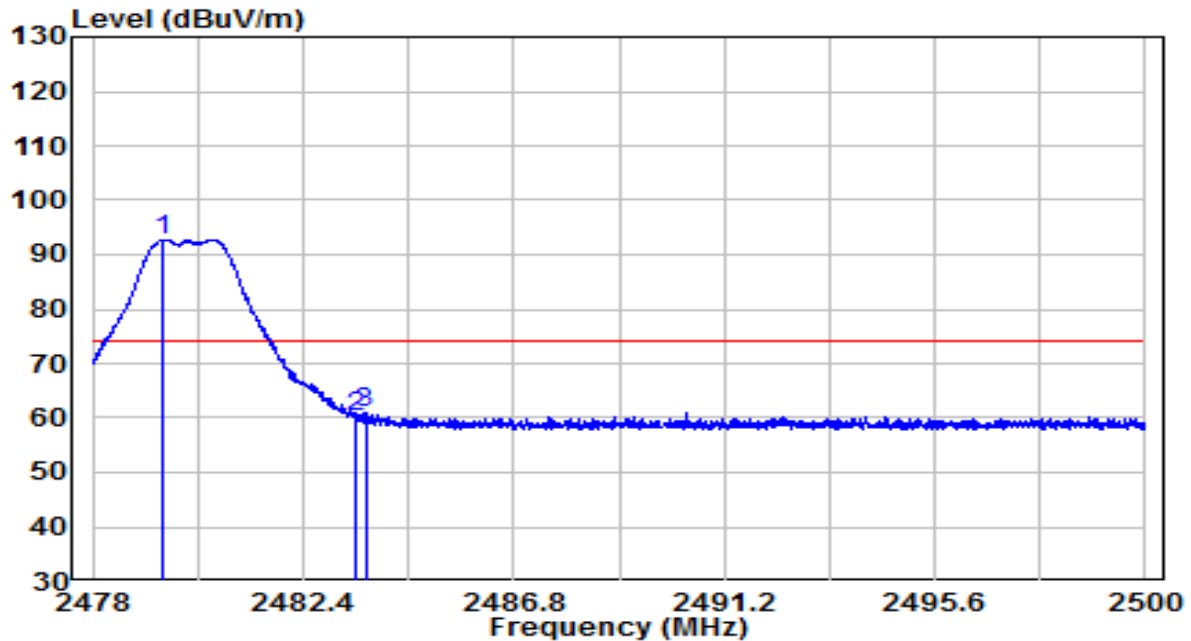

No	Frequency (MHz)	Reading (dBuV)	C.F (dB/m)	Measurement (dBuV/m)	Margin (dB)	Limit (dBuV/m)	Remark (QP/PK/AV)
1	* 2479.463	60.16	32.59	92.75	N/A	N/A	Peak
1	* 2479.463	60.16	32.59	72.75	N/A	N/A	Average
2	2483.500	27.63	32.61	60.24	-13.76	74.00	Peak
2	2483.500	27.63	32.61	40.24	-13.76	54.00	Average
3	2483.698	28.36	32.61	60.97	-13.03	74.00	Peak
3	2483.698	28.36	32.61	40.97	-13.03	54.00	Average

Note:

1. " *", means this data is the worst emission level.
2. C.F (Correction Factor) = Antenna Factor (dB/m)+ Cable Loss (dB)
3. Measurement(dBuV/m) = Reading(dBuV) + C.F (Correction Factor).
4. The emission levels of other frequencies are very lower than the limit and not show in test report.
5. Average Measure Level = Peak Measure Level + Duty Cycle Factor, Duty Cycle Factor= -20dB.

EUT	ASSESS POINT	Date of Test	2021-11-03
Factor	BBHA 9120D (1GHz~18GHz)_2021	Temp. / Humidity	26°C/48%
Polarity	Vertical	Site / Test Engineer	AC1 / Jay
Test Mode	Transmit by Zigbee at Channel 2480MHz	Test Voltage	By PoE

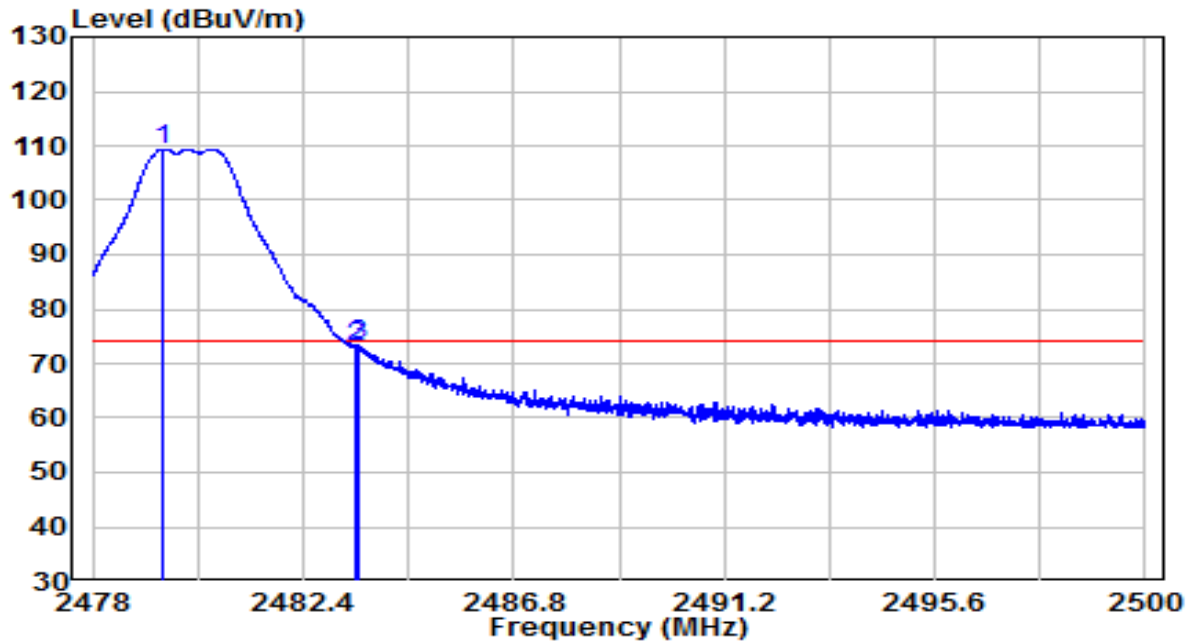

No	Frequency (MHz)	Reading (dBuV)	C.F (dB/m)	Measurement (dBuV/m)	Margin (dB)	Limit (dBuV/m)	Remark (QP/PK/AV)
1	* 2479.474	76.78	32.59	109.38	N/A	N/A	Peak
1	* 2479.474	76.78	32.59	89.38	N/A	N/A	Average
2	2483.500	40.32	32.61	72.93	-1.07	74.00	Peak
2	2483.500	40.32	32.61	52.93	-1.07	54.00	Average
3	2483.533	40.96	32.61	73.57	-0.43	74.00	Peak
3	2483.533	40.96	32.61	53.57	-0.43	54.00	Average

Note:

1. " *", means this data is the worst emission level.
2. C.F (Correction Factor) = Antenna Factor (dB/m)+ Cable Loss (dB)
3. Measurement(dBuV/m) = Reading(dBuV) + C.F (Correction Factor).
4. The emission levels of other frequencies are very lower than the limit and not show in test report.
5. Average Measure Level = Peak Measure Level + Duty Cycle Factor, Duty Cycle Factor= -20dB.

APEX0587 Filter 5#

EUT	ASSESS POINT	Date of Test	2021-11-03
Factor	BBHA 9120D (1GHz~18GHz)_2021	Temp. / Humidity	26°C/48%
Polarity	Horizontal	Site / Test Engineer	AC1 / Jay
Test Mode	Transmit by Zigbee at Channel 2405MHz	Test Voltage	By PoE

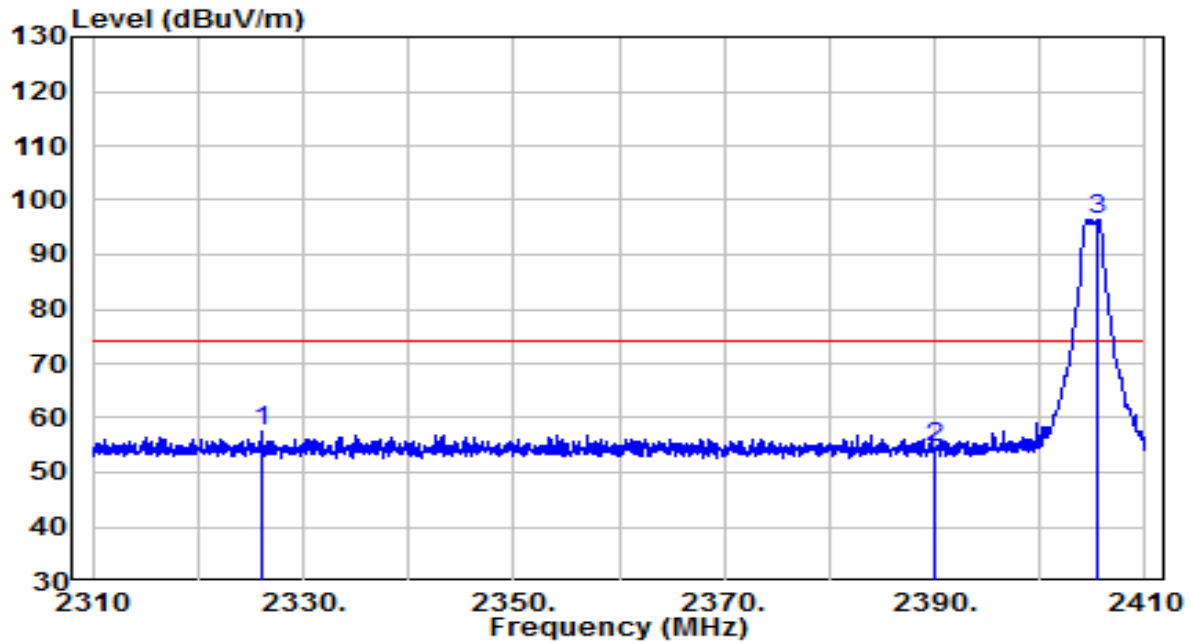

No	Frequency (MHz)	Reading (dBuV)	C.F (dB/m)	Measurement (dBuV/m)	Margin (dB)	Limit (dBuV/m)	Remark (QP/PK/AV)
1	2326.050	25.70	31.95	57.65	-16.35	74.00	Peak
1	2326.050	25.70	31.95	37.65	-16.35	54.00	Average
2	2390.000	22.38	32.22	54.60	-19.40	74.00	Peak
2	2390.000	22.38	32.22	34.60	-19.40	54.00	Average
3	* 2405.500	64.24	32.28	96.52	N/A	N/A	Peak
3	* 2405.500	64.24	32.28	76.52	N/A	N/A	Average

Note:

1. " *", means this data is the worst emission level.
2. C.F (Correction Factor) = Antenna Factor (dB/m)+ Cable Loss (dB)
3. Measurement(dBuV/m) = Reading(dBuV) + C.F (Correction Factor).
4. The emission levels of other frequencies are very lower than the limit and not show in test report.
5. Average Measure Level = Peak Measure Level + Duty Cycle Factor, Duty Cycle Factor= -20dB.

EUT	ASSESS POINT	Date of Test	2021-11-03
Factor	BBHA 9120D (1GHz~18GHz)_2021	Temp. / Humidity	26°C/48%
Polarity	Vertical	Site / Test Engineer	AC1 / Jay
Test Mode	Transmit by Zigbee at Channel 2405MHz	Test Voltage	By PoE

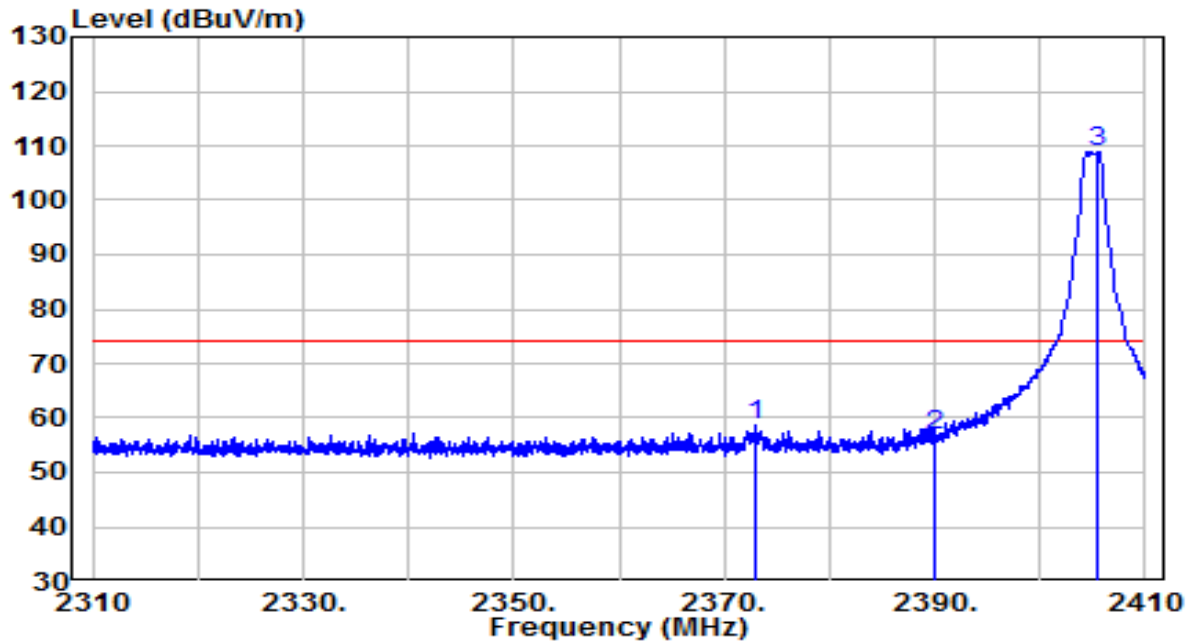

No	Frequency (MHz)	Reading (dBuV)	C.F (dB/m)	Measurement (dBuV/m)	Margin (dB)	Limit (dBuV/m)	Remark (QP/PK/AV)
1	2372.950	26.36	32.15	58.50	-15.50	74.00	Peak
1	2372.950	26.36	32.15	38.50	-15.50	54.00	Average
2	2390.000	24.74	32.22	56.96	-17.04	74.00	Peak
2	2390.000	24.74	32.22	36.96	-17.04	54.00	Average
3	* 2405.500	76.66	32.28	88.94	N/A	N/A	Peak
3	* 2405.500	76.66	32.28	88.94	N/A	N/A	Average

Note:

1. " *", means this data is the worst emission level.
2. C.F (Correction Factor) = Antenna Factor (dB/m)+ Cable Loss (dB)
3. Measurement(dBuV/m) = Reading(dBuV) + C.F (Correction Factor).
4. The emission levels of other frequencies are very lower than the limit and not show in test report.
5. Average Measure Level = Peak Measure Level + Duty Cycle Factor, Duty Cycle Factor= -20dB.

APEX0587 Filter 6#

EUT	ASSESS POINT	Date of Test	2021-11-03
Factor	BBHA 9120D (1GHz~18GHz)_2021	Temp. / Humidity	26°C/48%
Polarity	Horizontal	Site / Test Engineer	AC1 / Jay
Test Mode	Transmit by Zigbee at Channel 2480MHz	Test Voltage	By PoE

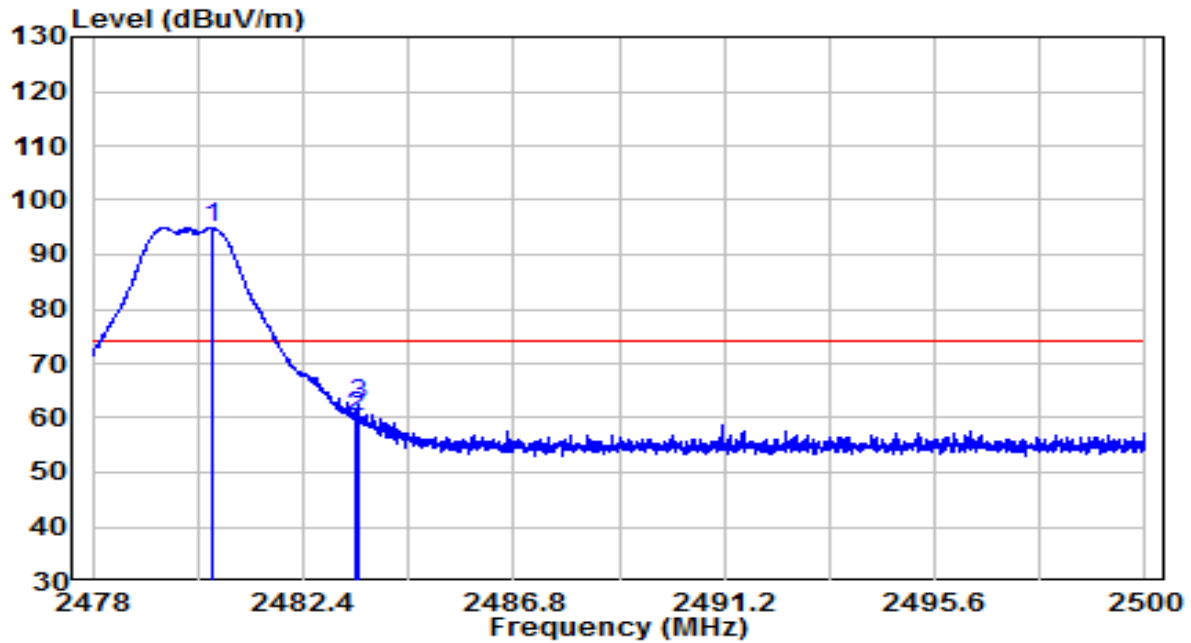

No	Frequency (MHz)	Reading (dBuV)	C.F (dB/m)	Measurement (dBuV/m)	Margin (dB)	Limit (dBuV/m)	Remark (QP/PK/AV)	
1	*	2480.497	62.31	32.60	94.90	N/A	N/A	Peak
1	*	2480.497	62.31	32.60	74.90	N/A	N/A	Average
2		2483.500	27.53	32.61	60.14	-13.86	74.00	Peak
2		2483.500	27.53	32.61	40.14	-13.86	54.00	Average
3		2483.533	29.76	32.61	62.37	-11.63	74.00	Peak
3		2483.533	29.76	32.61	42.37	-11.63	54.00	Average

Note:

- "*", means this data is the worst emission level.
- C.F (Correction Factor) = Antenna Factor (dB/m)+ Cable Loss (dB)
- Measurement(dBuV/m) = Reading(dBuV) + C.F (Correction Factor).
- The emission levels of other frequencies are very lower than the limit and not show in test report.
- Average Measure Level = Peak Measure Level + Duty Cycle Factor, Duty Cycle Factor= -20dB.

EUT	ASSESS POINT	Date of Test	2021-11-03
Factor	BBHA 9120D (1GHz~18GHz)_2021	Temp. / Humidity	26°C/48%
Polarity	Vertical	Site / Test Engineer	AC1 / Jay
Test Mode	Transmit by Zigbee at Channel 2480MHz	Test Voltage	By PoE

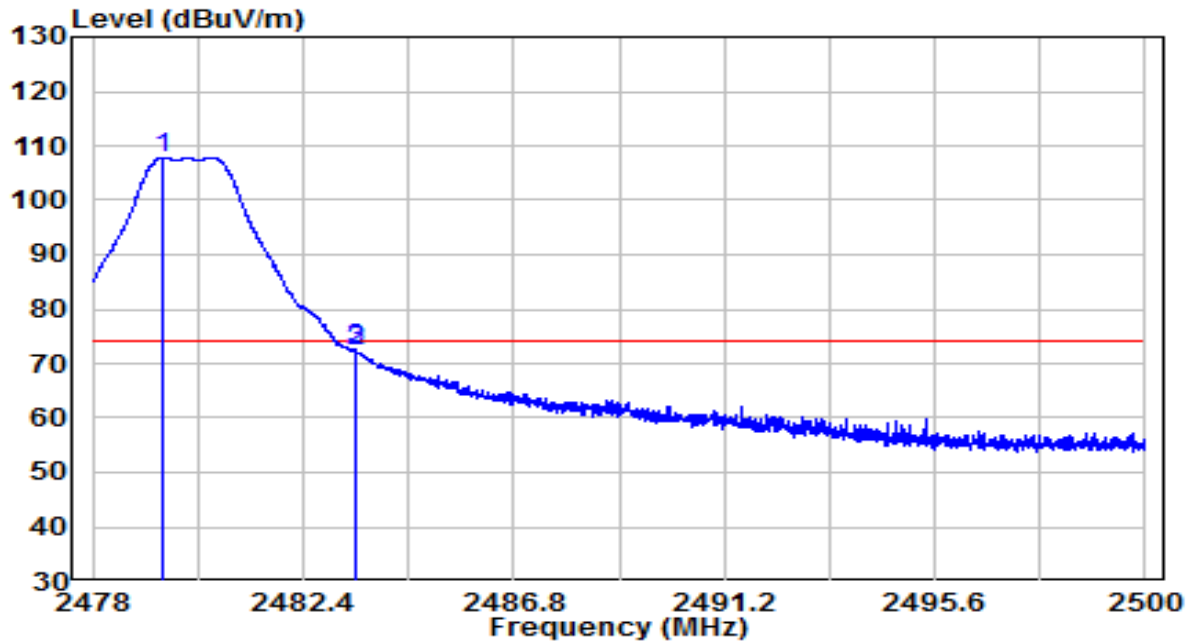

No	Frequency (MHz)	Reading (dBuV)	C.F (dB/m)	Measurement (dBuV/m)	Margin (dB)	Limit (dBuV/m)	Remark (QP/PK/AV)	
1	*	2479.463	75.33	32.59	107.92	N/A	N/A	Peak
1	*	2479.463	75.33	32.59	87.92	N/A	N/A	Average
2		2483.500	39.78	32.61	72.39	-1.61	74.00	Peak
2		2483.500	39.78	32.61	52.39	-1.61	54.00	Average
3		2483.522	39.91	32.61	72.52	-1.48	74.00	Peak
3		2483.522	39.91	32.61	52.52	-1.48	54.00	Average

Note:

1. " *", means this data is the worst emission level.
2. C.F (Correction Factor) = Antenna Factor (dB/m)+ Cable Loss (dB)
3. Measurement(dBuV/m) = Reading(dBuV) + C.F (Correction Factor).
4. The emission levels of other frequencies are very lower than the limit and not show in test report.
5. Average Measure Level = Peak Measure Level + Duty Cycle Factor, Duty Cycle Factor= -20dB.

APEX0584 Filter 4#

EUT	ASSESS POINT	Date of Test	2021-11-03
Factor	BBHA 9120D (1GHz~18GHz)_2021	Temp. / Humidity	25.6°C/45%
Polarity	Horizontal	Site / Test Engineer	AC1 / Jay
Test Mode	Transmit by Zigbee at Channel 2405MHz	Test Voltage	By PoE

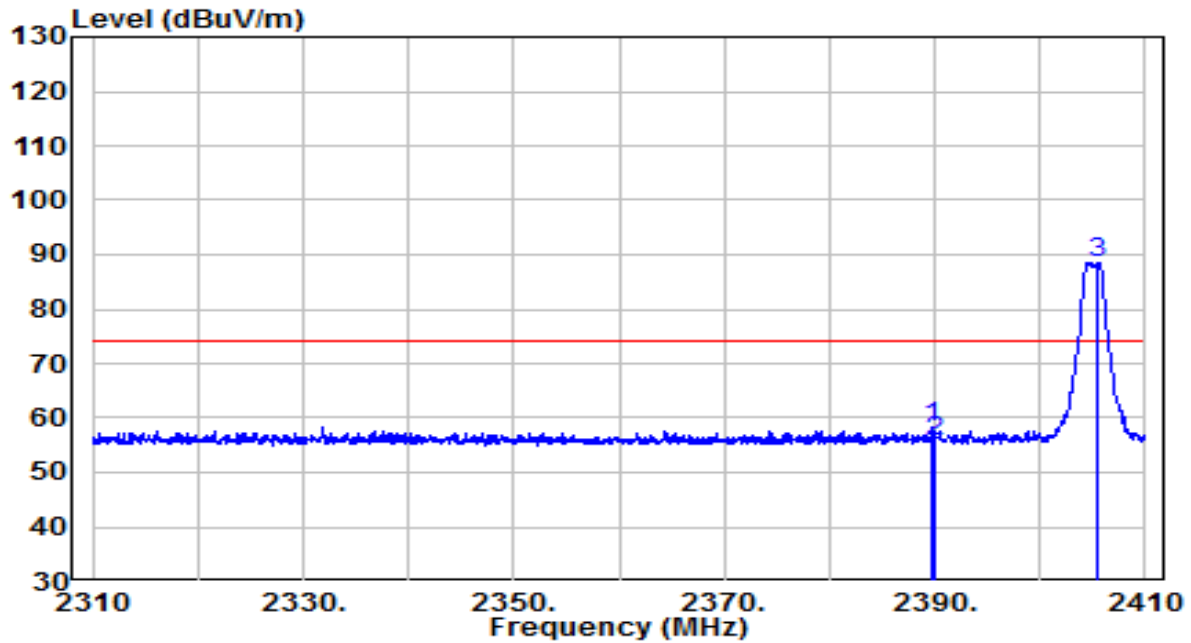

No	Frequency (MHz)	Reading (dBuV)	C.F (dB/m)	Measurement (dBuV/m)	Margin (dB)	Limit (dBuV/m)	Remark (QP/PK/AV)
1	2389.800	26.19	32.22	58.40	-15.60	74.00	Peak
1	2389.800	26.19	32.22	38.40	-15.60	54.00	Average
2	2390.000	23.38	32.22	55.60	-18.40	74.00	Peak
2	2390.000	23.38	32.22	35.60	-18.40	54.00	Average
3 *	2405.550	56.35	32.28	88.63	N/A	N/A	Peak
3 *	2405.550	56.35	32.28	68.63	N/A	N/A	Average

Note:

1. " *", means this data is the worst emission level.
2. C.F (Correction Factor) = Antenna Factor (dB/m)+ Cable Loss (dB)
3. Measurement(dBuV/m) = Reading(dBuV) + C.F (Correction Factor).
4. The emission levels of other frequencies are very lower than the limit and not show in test report.
5. Average Measure Level = Peak Measure Level + Duty Cycle Factor, Duty Cycle Factor= -20dB.

EUT	ASSESS POINT	Date of Test	2021-11-03
Factor	BBHA 9120D (1GHz~18GHz)_2021	Temp. / Humidity	25.6°C/45%
Polarity	Vertical	Site / Test Engineer	AC1 / Jay
Test Mode	Transmit by Zigbee at Channel 2405MHz	Test Voltage	By PoE

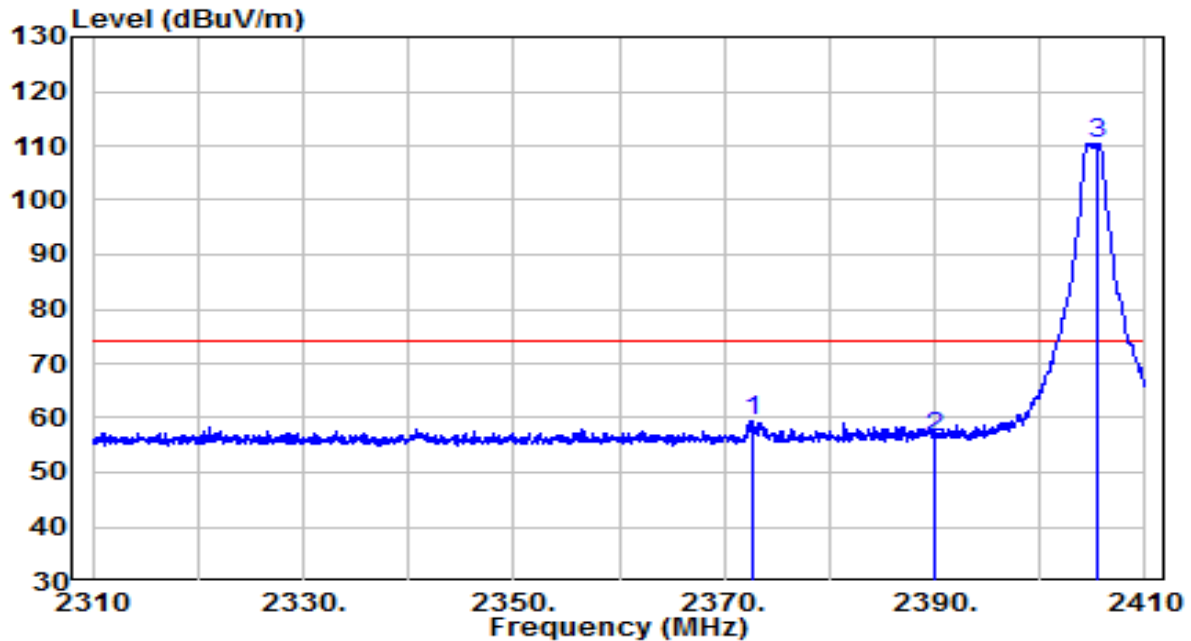

No	Frequency (MHz)	Reading (dBuV)	C.F (dB/m)	Measurement (dBuV/m)	Margin (dB)	Limit (dBuV/m)	Remark (QP/PK/AV)
1	2372.600	27.35	32.14	59.49	-14.51	74.00	Peak
1	2372.600	27.35	32.14	39.49	-14.51	54.00	Average
2	2390.000	24.12	32.22	56.34	-17.66	74.00	Peak
2	2390.000	24.12	32.22	36.34	-17.66	54.00	Average
3	* 2405.550	78.11	32.28	110.39	N/A	N/A	Peak
3	* 2405.550	78.11	32.28	90.39	N/A	N/A	Average

Note:

1. " *", means this data is the worst emission level.
2. C.F (Correction Factor) = Antenna Factor (dB/m)+ Cable Loss (dB)
3. Measurement(dBuV/m) = Reading(dBuV) + C.F (Correction Factor).
4. The emission levels of other frequencies are very lower than the limit and not show in test report.
5. Average Measure Level = Peak Measure Level + Duty Cycle Factor, Duty Cycle Factor= -20dB.

EUT	ASSESS POINT	Date of Test	2021-11-03
Factor	BBHA 9120D (1GHz~18GHz)_2021	Temp. / Humidity	25.6°C/45%
Polarity	Horizontal	Site / Test Engineer	AC1 / Jay
Test Mode	Transmit by Zigbee at Channel 2480MHz	Test Voltage	By PoE

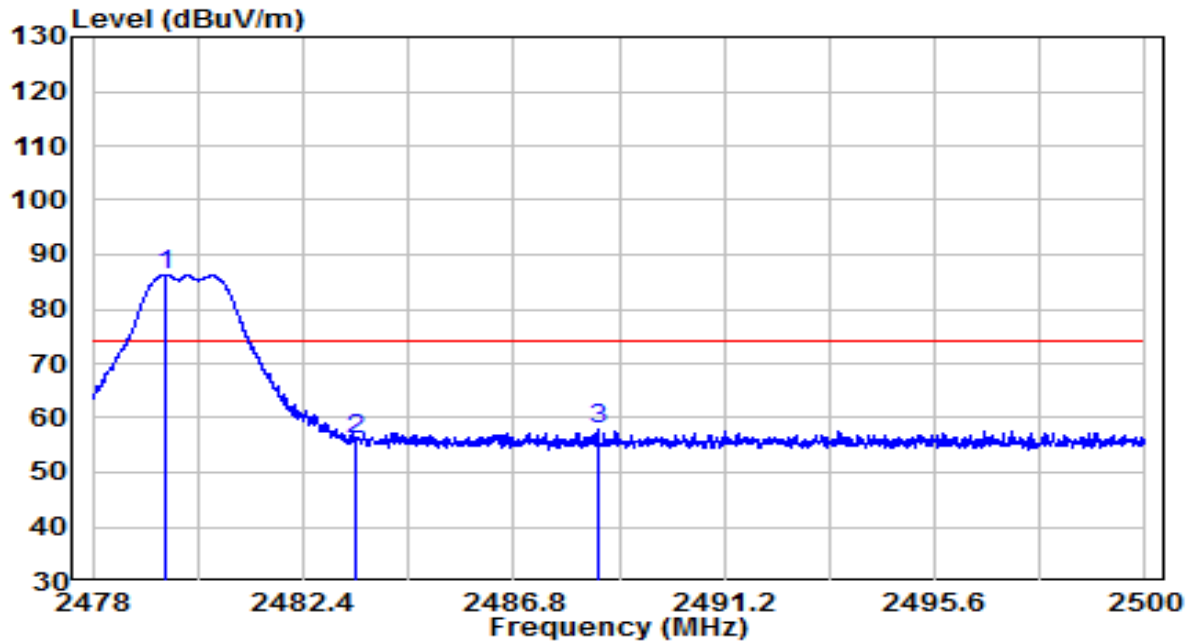

No	Frequency (MHz)	Reading (dBuV)	C.F (dB/m)	Measurement (dBuV/m)	Margin (dB)	Limit (dBuV/m)	Remark (QP/PK/AV)	
1	*	2479.507	53.79	32.59	86.39	N/A	N/A	Peak
1	*	2479.507	53.79	32.59	66.39	N/A	N/A	Average
2		2483.500	23.49	32.61	56.10	-17.90	74.00	Peak
2		2483.500	23.49	32.61	36.10	-17.90	54.00	Average
3		2488.571	25.27	32.63	57.90	-16.10	74.00	Peak
3		2488.571	25.27	32.63	37.90	-16.10	54.00	Average

Note:

1. " *", means this data is the worst emission level.
2. C.F (Correction Factor) = Antenna Factor (dB/m)+ Cable Loss (dB)
3. Measurement(dBuV/m) = Reading(dBuV) + C.F (Correction Factor).
4. The emission levels of other frequencies are very lower than the limit and not show in test report.
5. Average Measure Level = Peak Measure Level + Duty Cycle Factor, Duty Cycle Factor= -20dB.

EUT	ASSESS POINT	Date of Test	2021-11-03
Factor	BBHA 9120D (1GHz~18GHz)_2021	Temp. / Humidity	25.6°C/45%
Polarity	Vertical	Site / Test Engineer	AC1 / Jay
Test Mode	Transmit by Zigbee at Channel 2480MHz	Test Voltage	By PoE

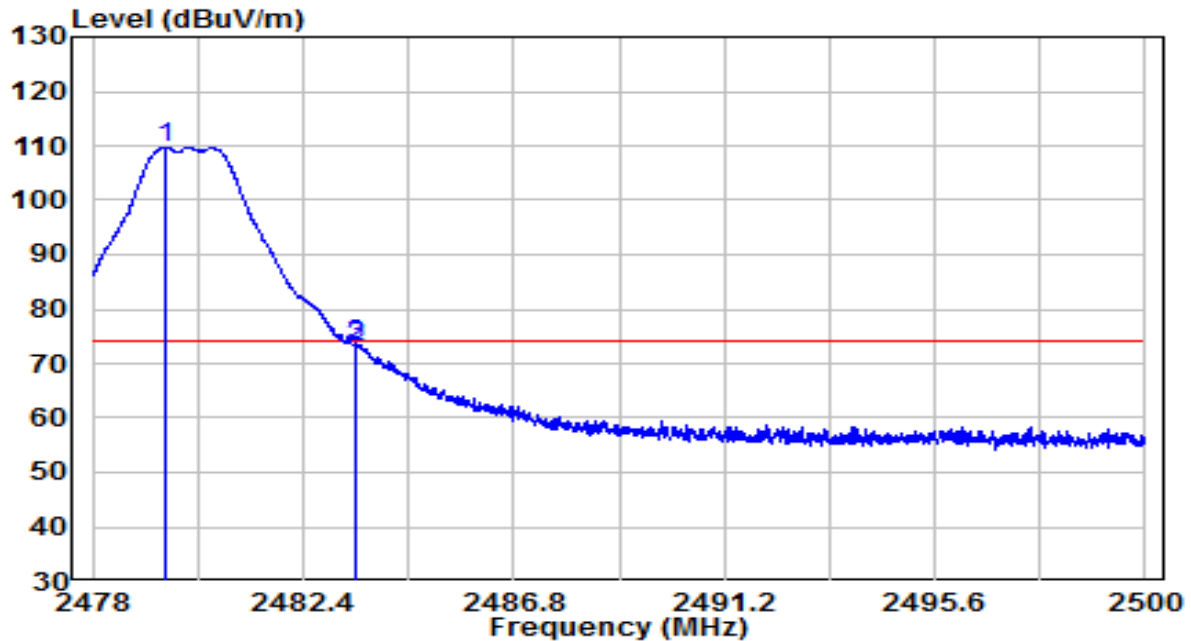

No	Frequency (MHz)	Reading (dBuV)	C.F (dB/m)	Measurement (dBuV/m)	Margin (dB)	Limit (dBuV/m)	Remark (QP/PK/AV)
1	* 2479.507	77.03	32.59	109.62	N/A	N/A	Peak
1	* 2479.507	77.03	32.59	89.62	N/A	N/A	Average
2	2483.500	40.57	32.61	73.18	-0.82	74.00	Peak
2	2483.500	40.57	32.61	53.18	-0.82	54.00	Average
3	2483.522	40.95	32.61	73.56	-0.44	74.00	Peak
3	2483.522	40.95	32.61	53.56	-0.44	54.00	Average

Note:

1. " *", means this data is the worst emission level.
2. C.F (Correction Factor) = Antenna Factor (dB/m)+ Cable Loss (dB)
3. Measurement(dBuV/m) = Reading(dBuV) + C.F (Correction Factor).
4. The emission levels of other frequencies are very lower than the limit and not show in test report.
5. Average Measure Level = Peak Measure Level + Duty Cycle Factor, Duty Cycle Factor= -20dB.

APEX0584 Filter 5#

EUT	ASSESS POINT	Date of Test	2021-11-05
Factor	BBHA 9120D (1GHz~18GHz)_2021	Temp. / Humidity	25.6°C/45%
Polarity	Horizontal	Site / Test Engineer	AC1 / Jay
Test Mode	Transmit by Zigbee at Channel 2405MHz	Test Voltage	By PoE

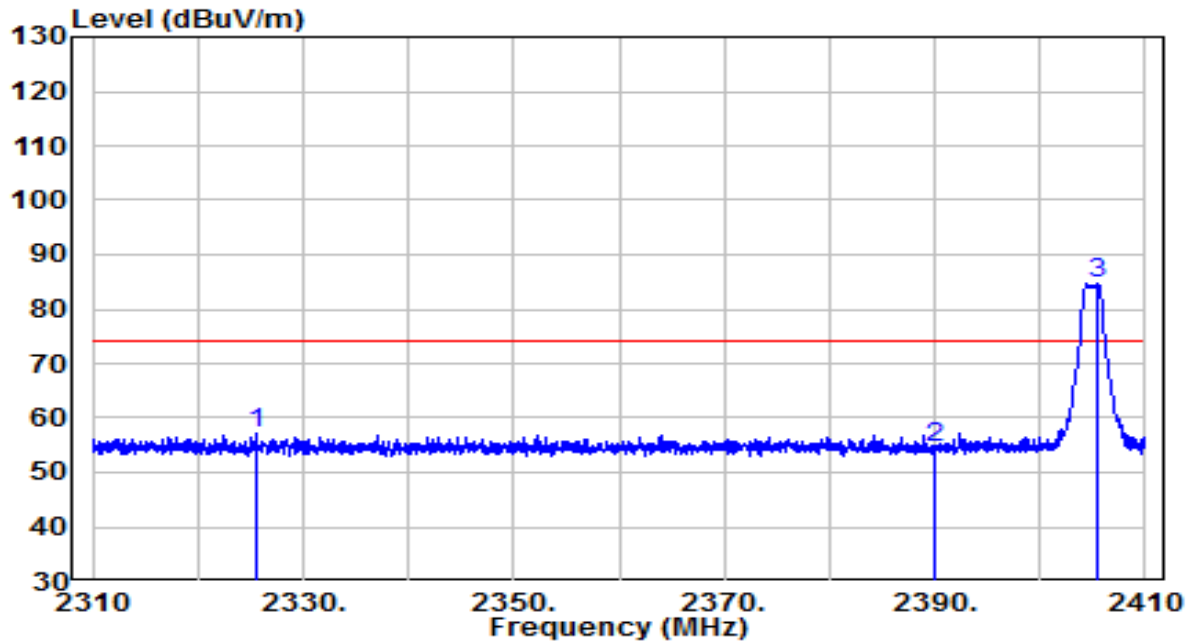

No	Frequency (MHz)	Reading (dBuV)	C.F (dB/m)	Measurement (dBuV/m)	Margin (dB)	Limit (dBuV/m)	Remark (QP/PK/AV)
1	2325.550	25.25	31.95	57.20	-16.80	74.00	Peak
1	2325.550	25.25	31.95	37.20	-16.80	54.00	Average
2	2390.000	22.43	32.22	54.64	-19.36	74.00	Peak
2	2390.000	22.43	32.22	34.64	-19.36	54.00	Average
3	* 2405.450	52.46	32.28	84.74	N/A	N/A	Peak
3	* 2405.450	52.46	32.28	64.74	N/A	N/A	Average

Note:

1. " *", means this data is the worst emission level.
2. C.F (Correction Factor) = Antenna Factor (dB/m)+ Cable Loss (dB)
3. Measurement(dBuV/m) = Reading(dBuV) + C.F (Correction Factor).
4. The emission levels of other frequencies are very lower than the limit and not show in test report.
5. Average Measure Level = Peak Measure Level + Duty Cycle Factor, Duty Cycle Factor= -20dB.

EUT	ASSESS POINT	Date of Test	2021-11-05
Factor	BBHA 9120D (1GHz~18GHz)_2021	Temp. / Humidity	25.6°C/45%
Polarity	Vertical	Site / Test Engineer	AC1 / Jay
Test Mode	Transmit by Zigbee at Channel 2405MHz	Test Voltage	By PoE

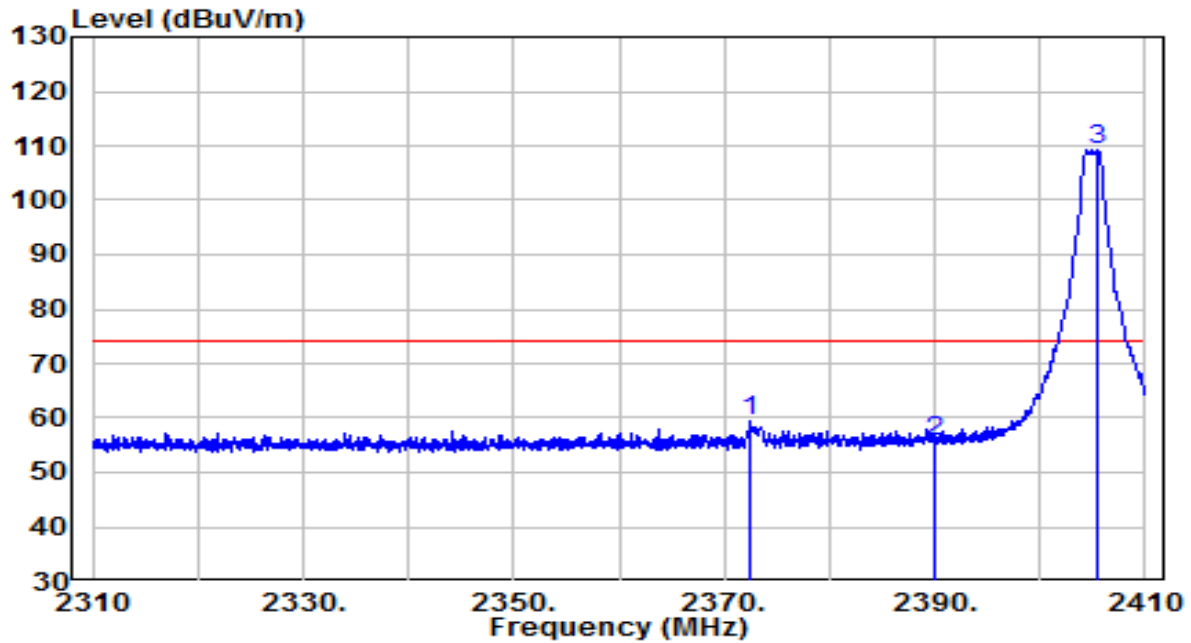

No	Frequency (MHz)	Reading (dBuV)	C.F (dB/m)	Measurement (dBuV/m)	Margin (dB)	Limit (dBuV/m)	Remark (QP/PK/AV)
1	2372.400	27.37	32.14	59.51	-14.49	74.00	Peak
1	2372.400	27.37	32.14	39.51	-14.49	54.00	Average
2	2390.000	23.31	32.22	55.52	-18.48	74.00	Peak
2	2390.000	23.31	32.22	35.52	-18.48	54.00	Average
3 *	2405.500	76.87	32.28	109.16	N/A	N/A	Peak
3 *	2405.500	76.87	32.28	89.16	N/A	N/A	Average

Note:

1. " *", means this data is the worst emission level.
2. C.F (Correction Factor) = Antenna Factor (dB/m)+ Cable Loss (dB)
3. Measurement(dBuV/m) = Reading(dBuV) + C.F (Correction Factor).
4. The emission levels of other frequencies are very lower than the limit and not show in test report.
5. Average Measure Level = Peak Measure Level + Duty Cycle Factor, Duty Cycle Factor= -20dB.

APEX0584 Filter 6#

EUT	ASSESS POINT	Date of Test	2021-11-05
Factor	BBHA 9120D (1GHz~18GHz)_2021	Temp. / Humidity	25.6°C/45%
Polarity	Horizontal	Site / Test Engineer	AC1 / Jay
Test Mode	Transmit by Zigbee at Channel 2480MHz	Test Voltage	By PoE

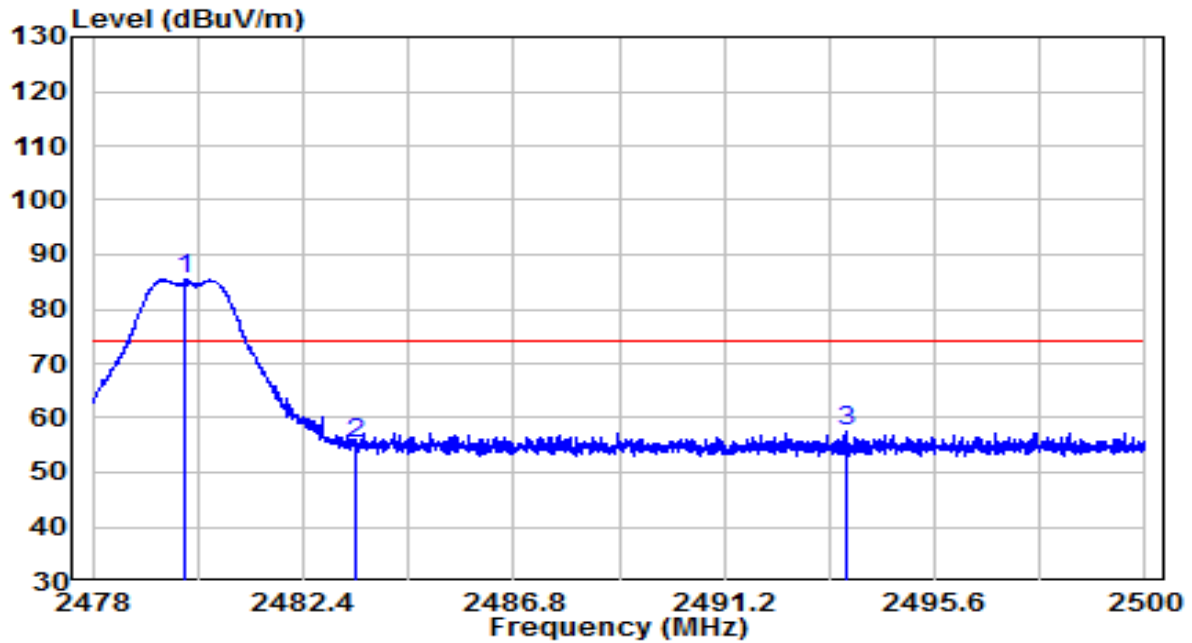

No	Frequency (MHz)	Reading (dBuV)	C.F (dB/m)	Measurement (dBuV/m)	Margin (dB)	Limit (dBuV/m)	Remark (QP/PK/AV)	
1	*	2479.936	52.78	32.60	85.37	N/A	N/A	Peak
1	*	2479.936	52.78	32.60	65.37	N/A	N/A	Average
2		2483.500	22.69	32.61	55.30	-18.70	74.00	Peak
2		2483.500	22.69	32.61	35.30	-18.70	54.00	Average
3		2493.730	24.80	32.65	57.46	-16.54	74.00	Peak
3		2493.730	24.80	32.65	37.46	-16.54	54.00	Average

Note:

1. " *", means this data is the worst emission level.
2. C.F (Correction Factor) = Antenna Factor (dB/m)+ Cable Loss (dB)
3. Measurement(dBuV/m) = Reading(dBuV) + C.F (Correction Factor).
4. The emission levels of other frequencies are very lower than the limit and not show in test report.
5. Average Measure Level = Peak Measure Level + Duty Cycle Factor, Duty Cycle Factor= -20dB.

EUT	ASSESS POINT	Date of Test	2021-11-05
Factor	BBHA 9120D (1GHz~18GHz)_2021	Temp. / Humidity	25.6°C/45%
Polarity	Vertical	Site / Test Engineer	AC1 / Jay
Test Mode	Transmit by Zigbee at Channel 2480MHz	Test Voltage	By PoE

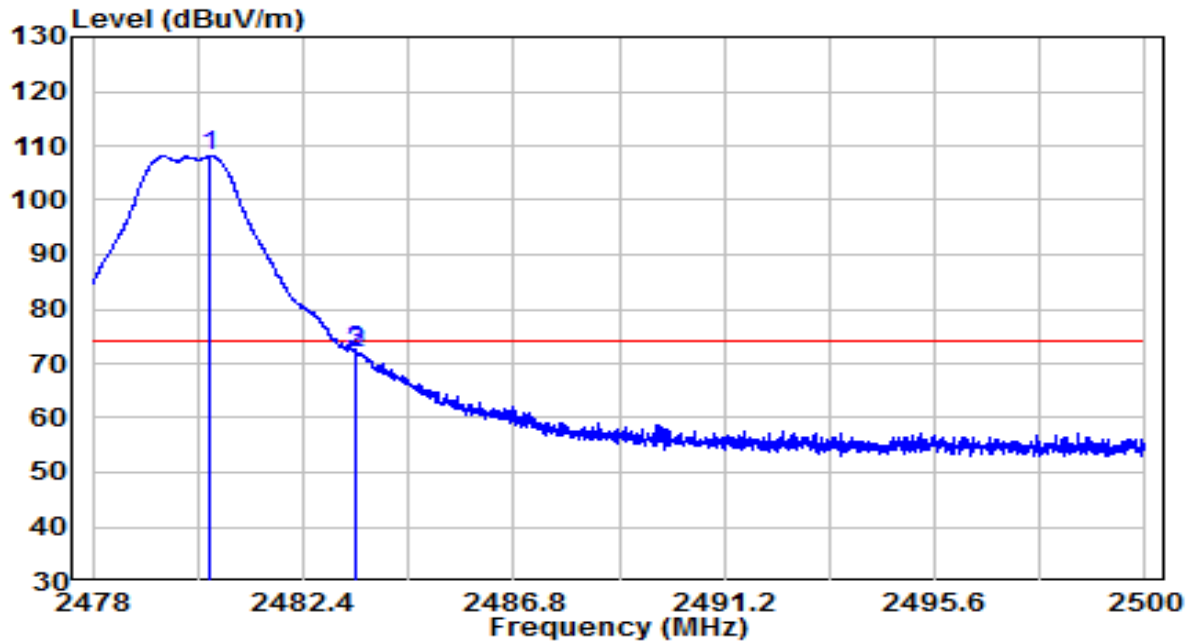

No	Frequency (MHz)	Reading (dBuV)	C.F (dB/m)	Measurement (dBuV/m)	Margin (dB)	Limit (dBuV/m)	Remark (QP/PK/AV)
1	* 2480.464	75.43	32.60	108.03	N/A	N/A	Peak
1	* 2480.464	75.43	32.60	88.03	N/A	N/A	Average
2	2483.500	39.16	32.61	71.77	-2.23	74.00	Peak
2	2483.500	39.16	32.61	51.77	-2.23	54.00	Average
3	2483.511	39.50	32.61	72.11	-1.89	74.00	Peak
3	2483.511	39.50	32.61	52.11	-1.89	54.00	Average

Note:

1. " *", means this data is the worst emission level.
2. C.F (Correction Factor) = Antenna Factor (dB/m)+ Cable Loss (dB)
3. Measurement(dBuV/m) = Reading(dBuV) + C.F (Correction Factor).
4. The emission levels of other frequencies are very lower than the limit and not show in test report.
5. Average Measure Level = Peak Measure Level + Duty Cycle Factor, Duty Cycle Factor= -20dB.

7.8. AC Conducted Emissions Measurement

7.8.1. Test Limit

FCC Part 15 Subpart C Paragraph 15.207 Limits		
Frequency (MHz)	QP (dBuV)	AV (dBuV)
0.15 - 0.50	66 - 56	56 - 46
0.50 - 5.0	56	46
5.0 - 30	60	50

Note 1: The lower limit shall apply at the transition frequencies.

Note 2: The limit decreases linearly with the logarithm of the frequency in the range 0.15MHz to 0.5MHz.

7.8.2. Test Setup

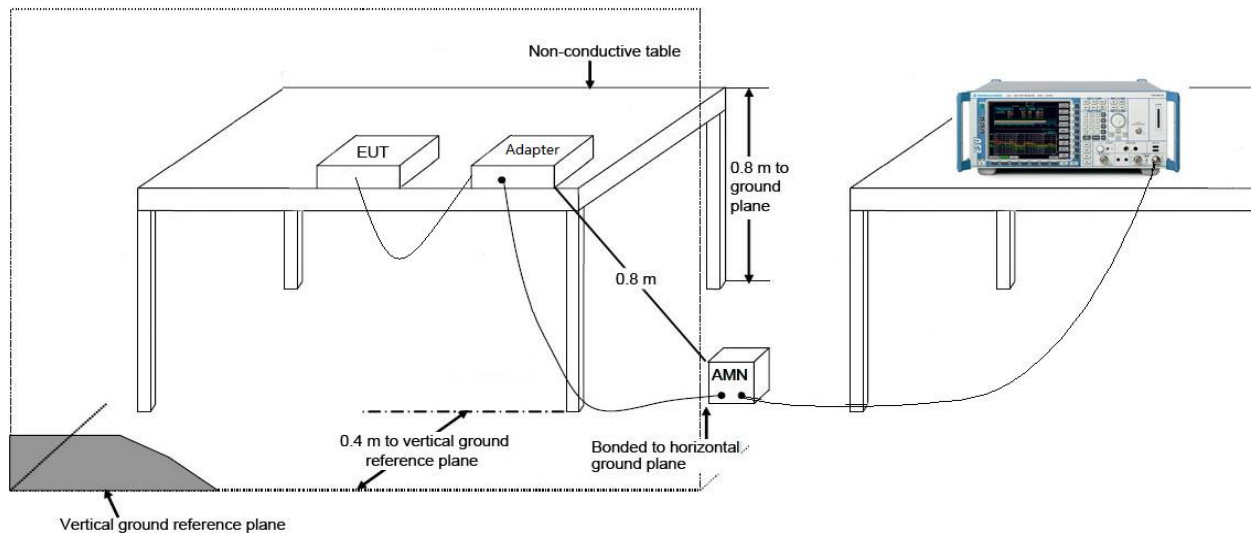

7.8.3. Test Result

EUT	ASSESS POINT (APEX0587)	Date of Test	2021-11-05
Factor	CE_ENV216-L1 (Filter OFF) _2021	Temp. / Humidity	25.2°C /47%
Polarity	Line1	Site / Test Engineer	SR2 / Eric Lin
Test Mode	Transmit by Zigbee at Channel 2405MHz	Test Voltage	120V / 60Hz

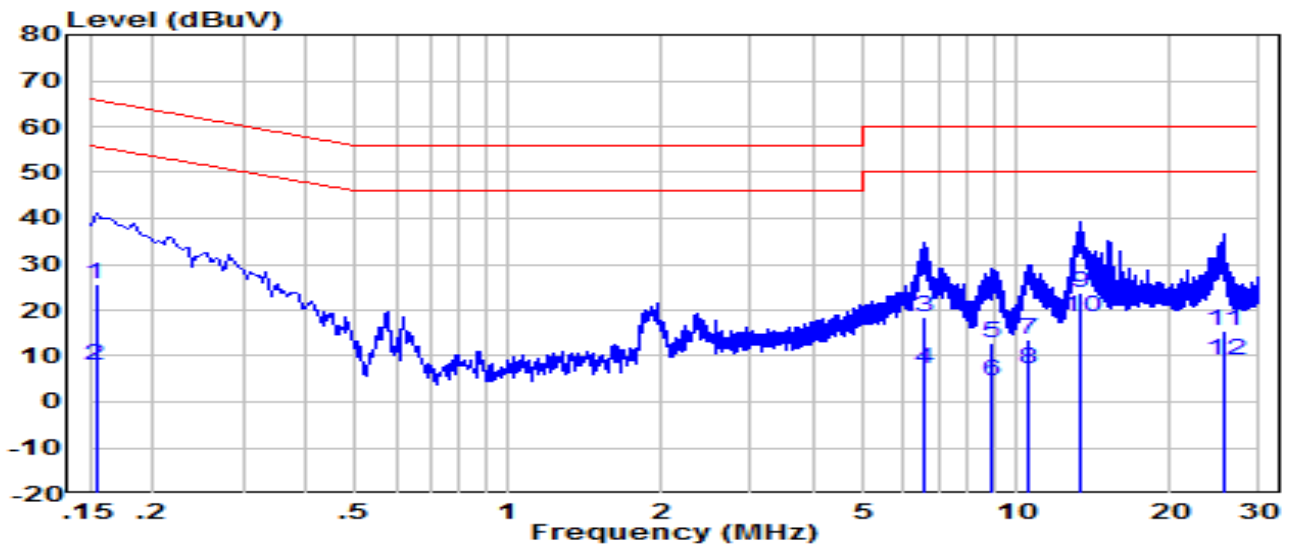

No	Frequency (MHz)	Reading (dBuV)	C.F (dB)	Measurement (dBuV)	Margin (dB)	Limit (dBuV)	Remark (QP/PK/AV)
1	0.154	16.09	9.61	25.70	-40.08	65.78	QP
2	0.154	-1.81	9.61	7.80	-47.98	55.78	Average
3	6.590	8.72	9.78	18.50	-41.50	60.00	QP
4	6.590	-2.48	9.78	7.30	-42.70	50.00	Average
5	8.930	3.06	9.84	12.90	-47.10	60.00	QP
6	8.930	-5.44	9.84	4.40	-45.60	50.00	Average
7	10.600	3.82	9.88	13.70	-46.30	60.00	QP
8	10.600	-2.78	9.88	7.10	-42.90	50.00	Average
9	13.290	14.00	9.90	23.90	-36.10	60.00	QP
10	* 13.290	8.60	9.90	18.50	-31.50	50.00	Average
11	25.480	5.29	10.01	15.30	-44.70	60.00	QP
12	25.480	-0.81	10.01	9.20	-40.80	50.00	Average

Note:

1. " *", means this data is the worst emission level.
2. C.F (Correction Factor) = LISN Factor (dB)+ Cable Loss (dB).
3. Measurement(dBuV) = Reading(dBuV) + C.F (Correction Factor).

EUT	ASSESS POINT (APEX0587)	Date of Test	2021-11-05
Factor	CE_ENV216-N (Filter OFF) _2021	Temp. / Humidity	25.2°C /47%
Polarity	Neutral	Site / Test Engineer	SR2 / Eric Lin
Test Mode	Transmit by Zigbee at Channel 2405MHz	Test Voltage	120V / 60Hz

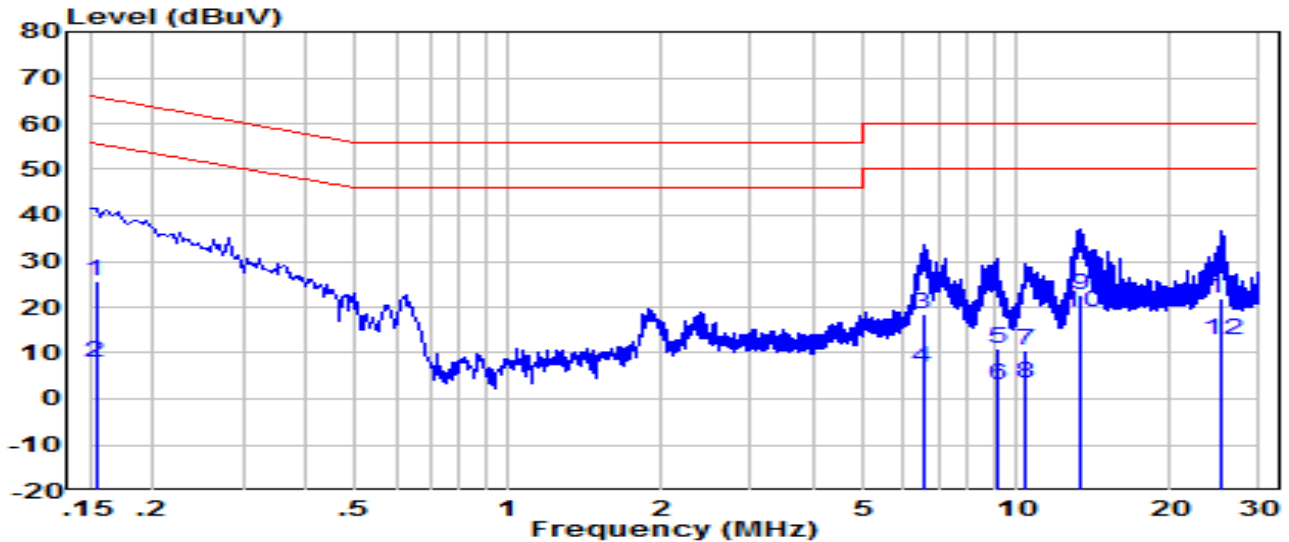

No	Frequency (MHz)	Reading (dBuV)	C.F (dB)	Measurement (dBuV)	Margin (dB)	Limit (dBuV)	Remark (QP/PK/AV)
1	0.154	15.98	9.62	25.60	-40.18	65.78	QP
2	0.154	-1.72	9.62	7.90	-47.88	55.78	Average
3	6.530	8.81	9.79	18.60	-41.40	60.00	QP
4	6.530	-2.89	9.79	6.90	-43.10	50.00	Average
5	9.120	1.03	9.87	10.90	-49.10	60.00	QP
6	9.120	-6.67	9.87	3.20	-46.80	50.00	Average
7	10.460	0.80	9.90	10.70	-49.30	60.00	QP
8	10.460	-6.40	9.90	3.50	-46.50	50.00	Average
9	13.390	12.86	9.94	22.80	-37.20	60.00	QP
10	* 13.390	8.96	9.94	18.90	-31.10	50.00	Average
11	25.360	11.69	10.11	21.80	-38.20	60.00	QP
12	25.360	2.69	10.11	12.80	-37.20	50.00	Average

Note:

1. " *", means this data is the worst emission level.
2. C.F (Correction Factor) = LISN Factor (dB)+ Cable Loss (dB).
3. Measurement(dBuV) = Reading(dBuV) + C.F (Correction Factor).

8. CONCLUSION

The data collected relate only the item(s) tested and show that the unit is compliance with Part 15C of the FCC Rules.

————— The End —————

Appendix A - Test Setup Photograph

Refer to "2105TW0005-Test setup photo" file.

Appendix B - EUT Photograph

Refer to "2105TW0005-EUT photo" file.