



DATE: 30 January 2017

**I.T.L. (PRODUCT TESTING) LTD.
IC/FCC Radio Test Report**

for

Cardo Systems, Inc.

Equipment under test:

**Bluetooth Communication System
for Motorcycles**

**scala rider FREECOM2
scala rider FREECOM4*
(2.4GHz Bluetooth Standard/EDR)**

*See customer's declaration on page 6

Tested by: _____
A. Yizhak

Approved by: _____
M. Zohar

This report must not be reproduced, except in full, without the written permission of I.T.L. (Product Testing) Ltd.
This report relates only to items tested.



Measurement/Technical Report for Cardo Systems, Inc.

Bluetooth Communication System for Motorcycles

scala rider FREECOM2

FCC ID: Q95ER22

IC: 4668A-ER22

This report concerns:	Original Grant:	X
	Class I Change:	
	Class II Change:	

Equipment type: DSS Part 15 Spread Spectrum Transmitter

Limits used: FCC Part 15, Sub-part C, Section 15.247
RSS 247, Issue 1: 2015
RSS Gen, Issue 4: 2014

Measurement procedures used are FCC Public Notice DA-00-705 and ANSI C63.10: 2013.

Application for Certification
prepared by:
R. Pinchuck
ITL (Product Testing) Ltd.
1 Bat Sheva Street
Lod 7116002
Israel
e-mail Rpinchuck@itl.co.il

Applicant for this device:
(different from "prepared by")
Avi Moato
Cardo Systems Inc.
1204 Parkway View Drive
Pittsburgh, Pennsylvania, USA, 15205
Tel: +972-3-7353111
Fax: +972-3-5623360
Email: moato@cardosystems.com



TABLE OF CONTENTS

1.	GENERAL INFORMATION	5
1.1	Administrative Information	5
1.2	List of Accreditations	7
1.3	Product Description	8
1.4	Test Methodology	8
1.5	Test Facility	8
1.6	Measurement Uncertainty	9
2.	SYSTEM TEST CONFIGURATION	10
2.1	Justification	10
2.2	EUT Exercise Software	10
2.3	Special Accessories	10
2.4	Equipment Modifications	10
2.5	Configuration of Tested System	11
3.	CONDUCTED & RADIATED MEASUREMENT TEST SET-UP PHOTOS	12
4.	CONDUCTED EMISSION FROM AC MAINS	15
4.1	Test Specification	15
4.2	Test Procedure	15
4.3	Test Limit	15
4.4	Test Results	16
4.5	Test Equipment Used; Conducted Emission	21
5.	20DB MINIMUM BANDWIDTH	22
5.1	Test Specification	22
5.2	Test Procedure	22
5.3	Test Limit	22
5.4	Test Results	22
5.5	Test Equipment Used, 20 dB Minimum Bandwidth	26
6.	26DB MINIMUM BANDWIDTH	27
6.1	Test Specification	27
6.2	Test Procedure	27
6.3	Test Limit	27
6.4	Test Results	27
6.5	Test Equipment Used, 26 dB Minimum Bandwidth	31
7.	NUMBER OF HOPPING FREQUENCIES	32
7.1	Test Specification	32
7.2	Test Procedure	32
7.3	Test Limit	32
7.4	Test Results	32
7.5	Test Equipment Used, Number of Hopping Frequencies	41
8.	CHANNEL FREQUENCY SEPARATION	42
8.1	Test Specification	42
8.2	Test Procedure	42
8.3	Test Limit	42
8.4	Test Results	42
8.5	Test Equipment Used, Channel Frequency Separation Test	44
9.	PEAK OUTPUT POWER	45
9.1	Test Specification	45
9.2	Test Procedure	45
9.3	Test Limit	45
9.4	Test Results	45
9.5	Test Equipment Used, Radiated Maximum Power Output	49



10.	DWELL TIME ON EACH CHANNEL	50
10.1	Test Specification	50
10.2	Test Procedure	50
10.3	Test Limit	50
10.4	Test Results	50
10.5	Test Equipment Used, Dwell Time on Each Channel	53
11.	BAND EDGE	54
11.1	Test Specification	54
11.2	Test Procedure	54
11.3	Test Limit	54
11.4	Test Results	54
11.5	Test Equipment Used, Band Edge Spectrum	59
12.	EMISSIONS IN NON-RESTRICTED FREQUENCY BANDS	60
12.1	Test Specification	60
12.2	Test Procedure	60
12.3	Test Limit	60
12.4	Test Results	60
12.5	Test Equipment Used, Emissions in Non-Restricted Frequency Bands	63
13.	EMISSIONS IN RESTRICTED FREQUENCY BANDS	64
13.1	Test Specification	64
13.2	Test Procedure	64
13.3	Test Limit	65
13.4	Test Results	65
13.5	Field Strength Calculation	68
13.6	Test Equipment Used, Emissions in Restricted Frequency Bands	69
14.	AVG. FACTOR CALCULATION	70
14.1	Test Equipment Used, Average Factor	72
15.	ANTENNA GAIN/INFORMATION	73
16.	R.F EXPOSURE/SAFETY	74
17.	APPENDIX A - CORRECTION FACTORS	76
17.1	Correction factors for CABLE from EMI receiver	76
17.2	Correction factor for RF CABLE for Semi Anechoic Chamber	77
17.3	Correction factors for Low Loss CABLE	78
17.4	Correction factors for ACTIVE LOOP ANTENNA	79
17.5	Correction factors for Biconical Antenna	80
17.6	Correction factors for Log Periodic Antenna	81
17.7	Correction factors for Horn ANTENNA	82



1. General Information

1.1 Administrative Information

Manufacturer: Cardo Systems, Inc.

Manufacturer's Address: 1204 Parkway View Drive
Pittsburgh, Pennsylvania, 15205
USA
Tel: +972-3-735-3111
Fax: +972-3-562-3360

Manufacturer's Representative: Avi Moato

Equipment Under Test (E.U.T): Bluetooth Communication System for
Motorcycles f

Product Marketing Name (PMN): scala rider FREECOM2
scala rider FREECOM4*

Equipment Serial No.: Not designated

HVIN: 1

Date of Receipt of E.U.T: November 1, 2016

Start of Test: November 2, 2016

End of Test: November 21, 2016

Test Laboratory Location: I.T.L (Product Testing) Ltd.
1 Batsheva St.,
Lod
ISRAEL 7120101

Test Specifications: FCC Part 15, Subpart C, Section 15.247
RSS 247, Issue 1: 2015
RSS Gen, Issue 4: 2014

*See customer's Declaration on following page.



DECLARATION

Date: December 25, 2016

I HEREBY DECLARE THE FOLLOWING REGARDING THE BELOW MODELS:

- 1) **PMN: Scala Rider Freecom2**
- 2) **PMN: Scala Rider Freecom4**

1. **The above models are identical physically, mechanically and electronically except for the below differences which are controlled by software.**
2. **Number of simultaneously connected devices:**
Freecom2 – Rider device + one (1) device;
Freecom4 - - Rider device +three (3) devices
3. **Feature Voice Menu:**
Only the Freecom4 has this feature.

Please relate to them (from a RADIO point of view) as the same product.

Thank you,

Avi Moato

Director of R&D

Cardo Systems, Inc.
1204 Parkway View Drive
Pittsburgh, PA 15205

Cardo Systems, Inc.
1204 Parkway View Drive
Pittsburgh, PA 15205 USA
www.cardosystems.com
Tel: +1 (412) 788.4533
Fax: +1 (412) 788.0270
✉ support@cardosystems.com



1.2 **List of Accreditations**

The EMC laboratory of I.T.L. is accredited by the following bodies:

1. The American Association for Laboratory Accreditation (A2LA) (U.S.A.), Certificate No. 1152.01.
2. The Federal Communications Commission (FCC) (U.S.A.), FCC Designation No. IL1005.
3. The Israel Ministry of the Environment (Israel), Registration No. 1104/01.
4. The Voluntary Control Council for Interference by Information Technology Equipment (VCCI) (Japan), Registration Numbers: C-3006, R-2729, T-1877, G-2245.
5. Industry Canada (Canada), IC File No.: 46405-4025; Site Nos. IC 4025A-1, IC 4025A-2.

I.T.L. Product Testing Ltd. is accredited by the American Association for Laboratory Accreditation (A2LA) and the results shown in this test report have been determined in accordance with I.T.L.'s terms of accreditation unless stated otherwise in the report.



1.3 **Product Description**

This product is a class 1 Bluetooth headset, Bluetooth intercom for motorbikes.

- Audio streaming via devices supporting Bluetooth Stereo A2DP and AVRCP profiles, Music Sharing: Rider and Passenger can enjoy the same stereo music (via A2DP)
- Built-in FM Radio with 6 station presets and automatic tuning

PMN:	scala rider FREECOM2 scala rider FREECOM4
Working voltage	Li Polymer battery 600mA 4.2V
Mode of operation	Transmitter
Modulation	Bluetooth Ver. 3.0, EDR class 1
Assigned Frequency Range	2400-2483.5MHz
Operating Frequency Range	2402-2480MHz
Transmit power	~18dBm
Antenna Gain	-2dBi

1.4 **Test Methodology**

Radiated testing was performed according to the procedures in FCC Public Notice DA 00-705 and ANSI C63.10: 2013. Radiated testing was performed at an antenna to EUT distance of 3 meters.

1.5 **Test Facility**

Emissions tests were performed at I.T.L.'s testing facility in Lod, Israel. I.T.L.'s EMC Laboratory is accredited by A2LA, certificate No. 1152.01 and its FCC Designation Number is IL1005.



1.6 **Measurement Uncertainty**

Conducted Emission

Conducted Emission (CISPR 11, EN 55011, CISPR 22, EN 55022, ANSI C63.4)
0.15 – 30 MHz:

Expanded Uncertainty (95% Confidence, K=2):

± 3.6 dB

Radiated Emission

Radiated Emission (CISPR 11, EN 55011, CISPR 22, EN 55022, ANSI C63.4)
for open site 30-1000MHz:

Expanded Uncertainty (95% Confidence, K=2):

± 4.96 dB



2. System Test Configuration

2.1 Justification

Exploratory emission testing was performed in 3 orthogonal polarities to determine the “worst case” polarity for full testing.

According to below results the worst case was the X axis.

Frequency	X				Y				Z			
	Field Strength	2 rd H	3 th H	Band Edge	Field Strength	2 rd H	3 th H	Band Edge	Field Strength	2 rd H	3 th H	Band Edge
	(dBuV/m)	(dBuV/m)	(dBuV/m)	(dBuV/m)	(dBuV/m)	(dBuV/m)	(dBuV/m)	(dBuV/m)	(dBuV/m)	(dBuV/m)	(dBuV/m)	(dBuV/m)
2402.0	101.83	62.2	69.2	51.9	98.43	66.1	68.8	51.9	97.07	61.9	64.5	51.9
2441.0	102.8	62.6	57.9	-	99.88	66.2	64.5	-	97.98	62.8	59.2	-
2480.0	101.14	65.4	62.3	49.7	98.37	58.7	67.7	49.7	98.19	62.8	66.6	50.1

Figure 1. Screening Results

The E.U.T. was evaluated when transmitting at the Low (2402MHz), Mid (2441MHz) and High (2480MHz) channels in the installation position.

All tests, other than spurious radiated emissions, were performed conducted.

2.2 EUT Exercise Software

No special exercise software was used.

2.3 Special Accessories

No special accessories were needed in order to achieve compliance.

2.4 Equipment Modifications

No modifications were needed in order to achieve compliance.

2.5 Configuration of Tested System

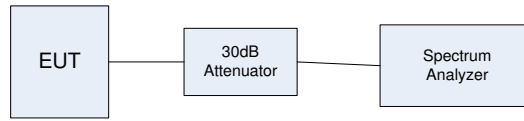

Figure 2. Configuration of Tested System – Conducted Emission on Antenna Ports

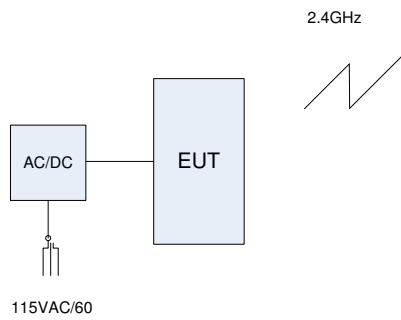

Figure 3. Configuration of Tested System – Conducted Emission on AC Line

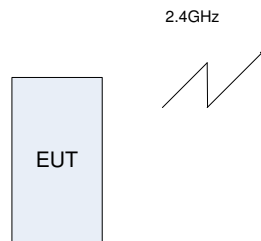

Figure 4. Configuration of Tested System – Radiated Emission

3. Conducted & Radiated Measurement Test Set-Up Photos

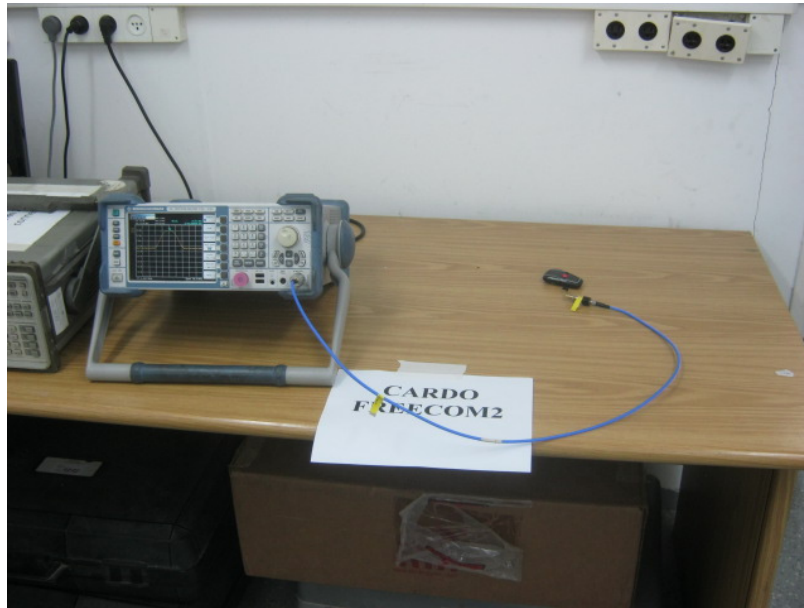

Figure 5. Conducted Emission From Antenna Ports Test Set-Up



Figure 6. Conducted Emission From AC Mains Test

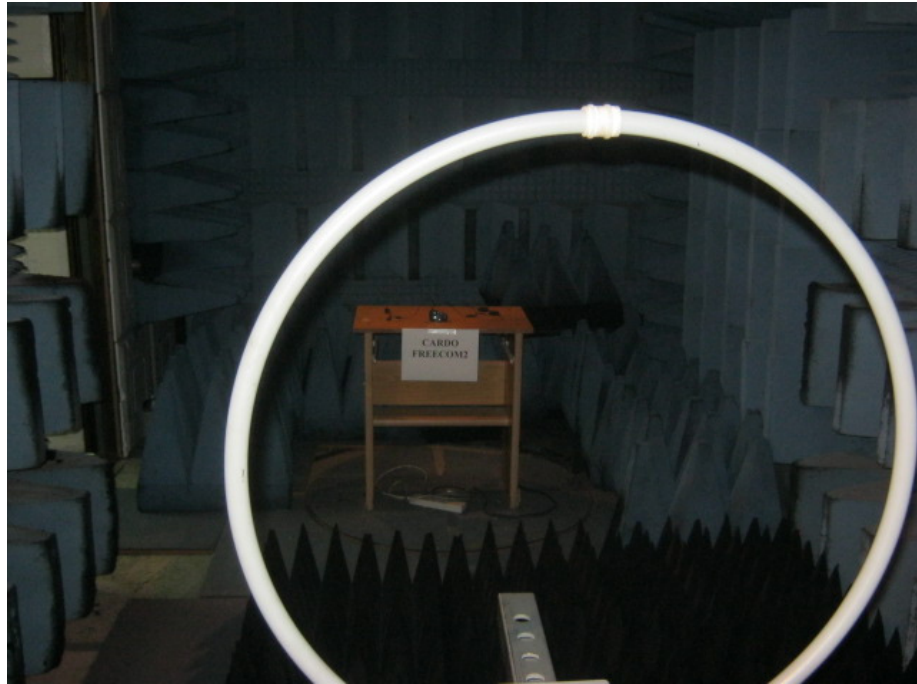

Figure 7. Radiated Emission Test

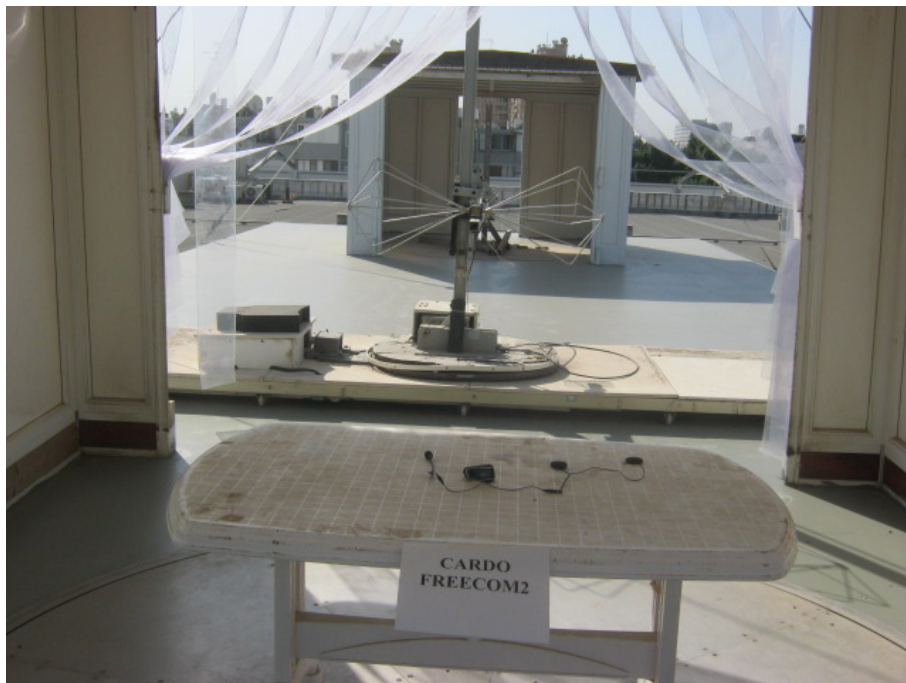

Figure 8. Radiated Emission Test

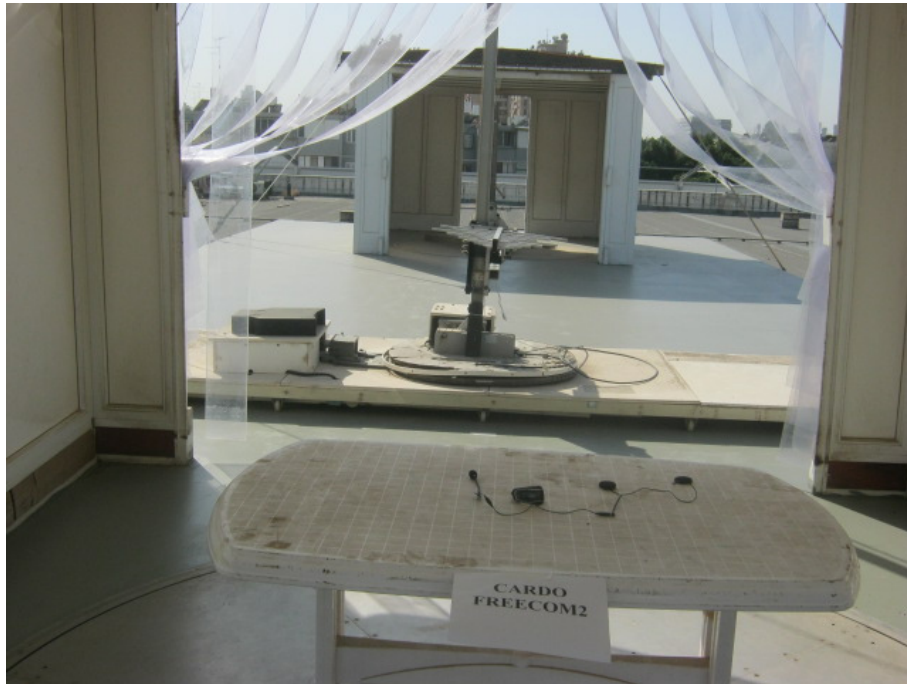

Figure 9. Radiated Emission Test



Figure 10. Radiated Emission Test



4. Conducted Emission From AC Mains

4.1 Test Specification

FCC Part 15, Subpart C, Section 15.207
RSS Gen, Issue 4, Clause 8.8

4.2 Test Procedure

(Temperature (24°C)/ Humidity (40%RH))

The E.U.T operation mode and test setup are as described in Section 2 of this report. In order to minimize background noise interference, the conducted emission testing was performed inside a shielded room, with the E.U.T placed on a 0.8 meter high wooden table, 0.4 meter from the room's vertical wall. In the case of a floor-standing E.U.T., it was placed on the horizontal ground plane.

The E.U.T was powered from 115 V AC / 60 Hz via 50 Ohm / 50 μ Hn Line Impedance Stabilization Network (LISN) on the phase and neutral lines. The LISN's were grounded to the shielded room ground plane (floor), and were kept at least 0.8 meters from the nearest boundary of the E.U.T

The center of the E.U.T.'s AC cable was folded back and forth, in order to form a bundle less than 0.40 meters and a total cable length of 1 meter.

The effect of varying the position of the cables was investigated to find the configuration that produces maximum emission. The configuration tested is shown in the photograph, *Figure 6. Conducted Emission From AC Mains.*

The emission voltages at the LISN's outputs were measured using a computerized receiver, complying with CISPR 16 requirements. The specification limits are loaded to the receiver and are displayed on the receiver's spectrum display.

The E.U.T was evaluated in TX operation mode

A frequency scan between 0.15 and 30 MHz was performed at 9 kHz I.F. band width, using peak detection.

The spectral components having the highest level on each line were measured using a quasi-peak and average detector.

4.3 Test Limit

Frequency of emission (MHz)	Conducted limit (dB μ V)	
	Quasi-peak	Average
0.15-0.5	66 to 56*	56 to 46*
0.5-5	56	46
5-30	60	50

* Decreases with the logarithm of the frequency.



4.4 **Test Results**

JUDGEMENT: Passed by 28.64 dB

The margin between the emission levels and the specification limit is, in the worst case, 29.31 dB for the phase line at 0.298 MHz and 28.64 dB at 27.62 MHz for the neutral line.

The EUT met the F.C.C. Part 15, Subpart C and RSS Gen, Issue 4, Clause 8.8 specification requirements.

The details of the highest emissions are given in *Figure 11* to *Figure 14*.



Conducted Emission

E.U.T Description Bluetooth Communication
System for Motorcycles
Type scala rider FREECOM2
Serial Number: Not designated

Specification: FCC Part 15, Subpart C
Lead: Phase
Detectors: : Peak, Quasi-peak, Average
Power Operation AC/DC adapter

EDIT PEAK LIST (Final Measurement Results)				
Trace1:		CE22BQP		
Trace2:		CE22BAP		
Trace3:		---		
	TRACE	FREQUENCY	LEVEL dBµV	DELTA LIMIT dB
2	Average	222 kHz	12.33	-40.41
1	Quasi Peak	238 kHz	25.45	-36.71
1	Quasi Peak	298 kHz	30.98	-29.31
2	Average	298 kHz	14.23	-36.06
1	Quasi Peak	454 kHz	25.61	-31.18
2	Average	574 kHz	10.37	-35.62
2	Average	774 kHz	9.50	-36.49
1	Quasi Peak	1.166 MHz	21.71	-34.28
1	Quasi Peak	1.478 MHz	23.37	-32.62
2	Average	1.546 MHz	11.53	-34.46
1	Quasi Peak	2.358 MHz	22.41	-33.58
2	Average	3.062 MHz	9.08	-36.91
1	Quasi Peak	3.65 MHz	16.35	-39.64
2	Average	3.97 MHz	5.57	-40.42
1	Quasi Peak	7.638 MHz	14.19	-45.81
2	Average	10.326 MHz	6.34	-43.65
1	Quasi Peak	10.822 MHz	13.75	-46.25
2	Average	16.534 MHz	6.74	-43.25
2	Average	22.598 MHz	12.61	-37.38
1	Quasi Peak	27.574 MHz	17.99	-42.00

Date: 21.NOV.2016 15:43:14

Figure 11. Detectors: Peak, Quasi-peak, Average

Note: QP Delta/Av Delta refers to the test results obtained minus specified requirement; thus a positive number indicates failure, and a negative result indicates that the product passes the test.



Conducted Emission

E.U.T Description Bluetooth Communication System for Motorcycles
Type scala rider FREECOM2
Serial Number: Not designated

Specification: FCC Part 15, Subpart C
Lead: Phase
Detectors: Peak, Quasi-peak, Average
Power Operation AC/DC adapter

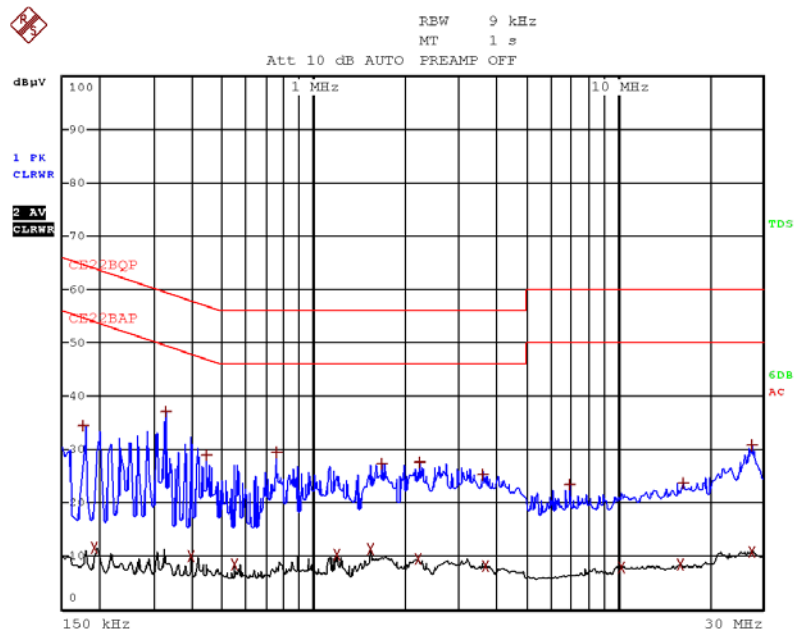

Date: 21.NOV.2016 15:50:34

Figure 12. Detectors: Peak, Quasi-peak, Average



Conducted Emission

E.U.T Description: Bluetooth Communication System for Motorcycles
 Type: scala rider FREECOM2
 Serial Number: Not designated

Specification: FCC Part 15, Subpart C
 Lead: Neutral
 Detectors: Peak, Quasi-peak, Average
 Power Operation: AC/DC adapter

EDIT PEAK LIST (Final Measurement Results)			
TRACE	FREQUENCY	LEVEL dBμV	DELTA LIMIT dB
Trace1:	CE22BQP		
Trace2:	CE22BAP		
Trace3:	---		
2 Average	198 kHz	13.17	-40.52
1 Quasi Peak	250 kHz	20.85	-40.90
1 Quasi Peak	322 kHz	24.08	-35.57
2 Average	330 kHz	17.00	-32.44
1 Quasi Peak	438 kHz	21.78	-35.31
2 Average	734 kHz	11.33	-34.67
1 Quasi Peak	890 kHz	18.29	-37.71
2 Average	890 kHz	10.27	-35.72
1 Quasi Peak	1.422 MHz	14.53	-41.46
2 Average	1.546 MHz	10.44	-35.55
2 Average	3.122 MHz	9.99	-36.00
1 Quasi Peak	3.474 MHz	18.84	-37.15
1 Quasi Peak	3.61 MHz	18.93	-37.06
2 Average	3.61 MHz	8.79	-37.20
2 Average	9.418 MHz	7.65	-42.34
1 Quasi Peak	9.966 MHz	15.39	-44.60
1 Quasi Peak	15.53 MHz	18.31	-41.68
2 Average	17.474 MHz	9.19	-40.81
1 Quasi Peak	27.622 MHz	31.35	-28.64
2 Average	27.834 MHz	19.34	-30.66

Date: 21.NOV.2016 15:58:01

Figure 13. Detectors: Peak, Quasi-peak, Average

Note: QP Delta/Av Delta refers to the test results obtained minus specified requirement; thus a positive number indicates failure, and a negative result indicates that the product passes the test.



Conducted Emission

E.U.T Description Bluetooth Communication System for Motorcycles
Type scala rider FREECOM2
Serial Number: Not designated

Specification: FCC Part 15, Subpart C
Lead: Neutral
Detectors: Peak, Quasi-peak, Average
Power Operation AC/DC adapter

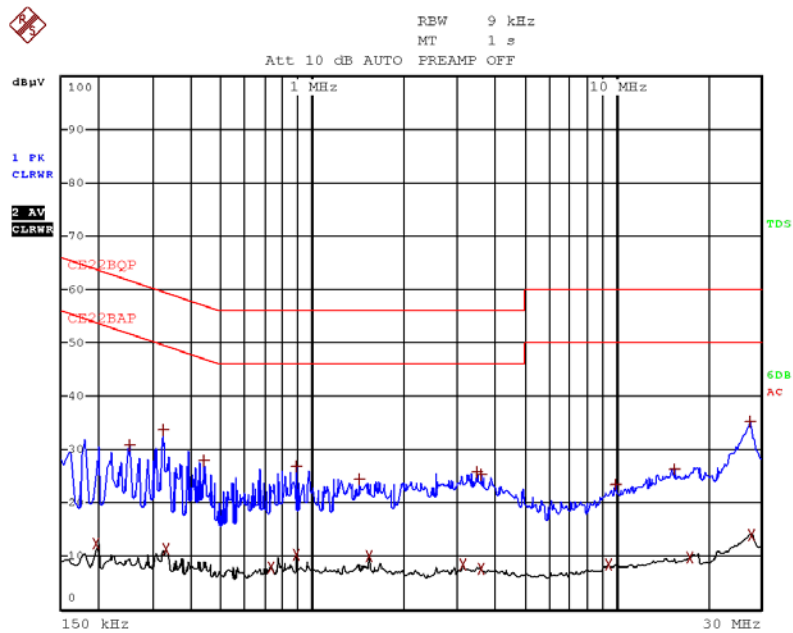

Date: 21.NOV.2016 15:56:28

Figure 14 Detectors: Peak, Quasi-peak, Average



4.5 Test Equipment Used; Conducted Emission

Instrument	Manufacturer	Model	Serial No.	Last Calibration Date	Next Calibration Due
LISN	Fischer	FCC-LISN-25A	127	June 23, 2016	June 23, 2017
Transient Limiter	HP	11947A	3107A03041	June 15, 2016	June 15, 2017
EMI Receiver	Rohde & Schwarz	ESCI7	100724	February 29, 2016	March 1, 2017
Low Loss Cable	Huber Suhner	-	705A009301 EIM	May 30, 2016	May 30, 2017

Figure 15 Test Equipment Used



5. 20dB Minimum Bandwidth

5.1 Test Specification

F.C.C. Part 15, Subpart C, Section 15.247(a)(1)
RSS 247, Issue 1, Section 5.1(1)

5.2 Test Procedure

(Temperature (23°C)/ Humidity (41%RH))

The E.U.T. antenna terminal was connected to the Spectrum Analyzer through an external attenuator and an appropriate coaxial cable .The transmitter unit operated with normal modulation. The spectrum analyzer was set to the following parameters:

Span = ~ 2 to 3 times the 20 dB bandwidth, centered on a hopping channel RBW \geq 1% of the 20 dB bandwidth

Detector Function: Peak, Trace: Maximum Hold.

The E.U.T. was tested at Low, Mid and High channels.

5.3 Test Limit

N/A

5.4 Test Results

Operation Frequency (MHz)	Modulation	Bandwidth Reading (MHz)
2402	Standard	1.118
2441	Standard	1.138
2480	Standard	1.118
2402	EDR	1.377
2441	EDR	1.389
2480	EDR	1.389

Figure 16 Test Results

JUDGEMENT: Passed

For additional information see *Figure 17* to *Figure 22*.

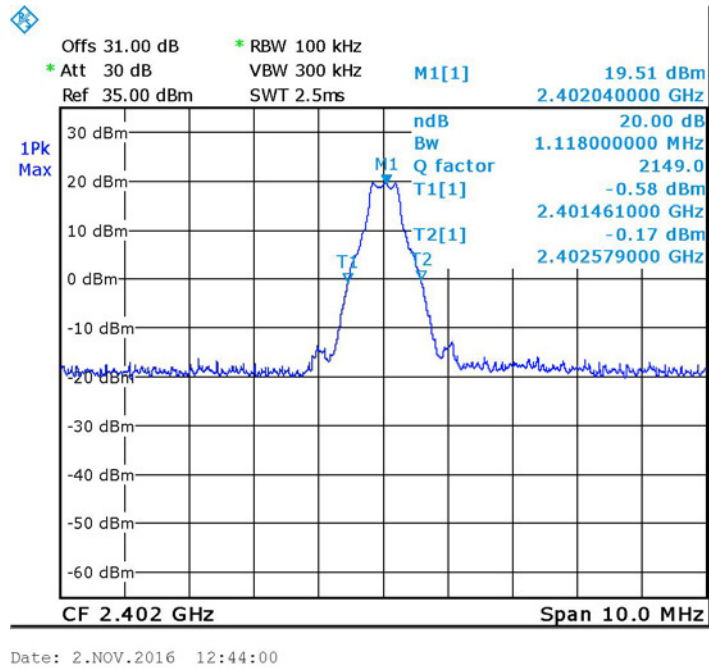

Figure 17. —2402 MHz – Low Standard Modulation

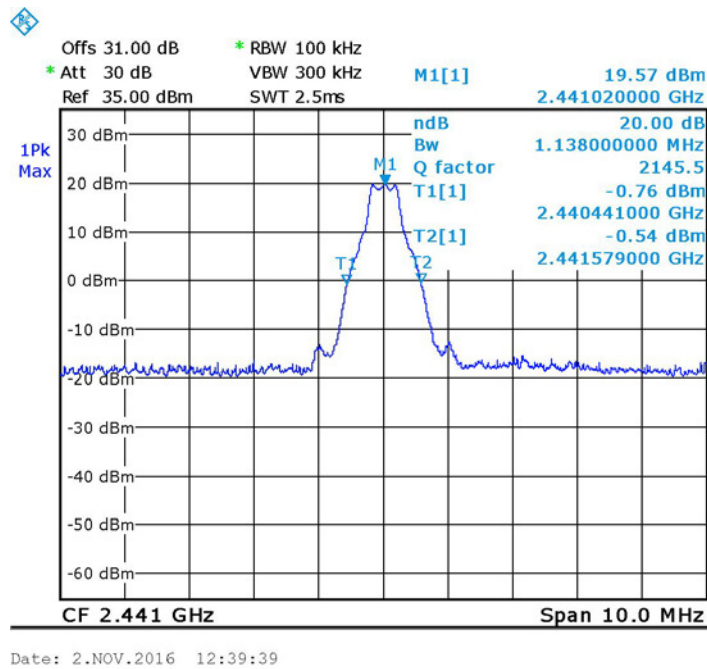
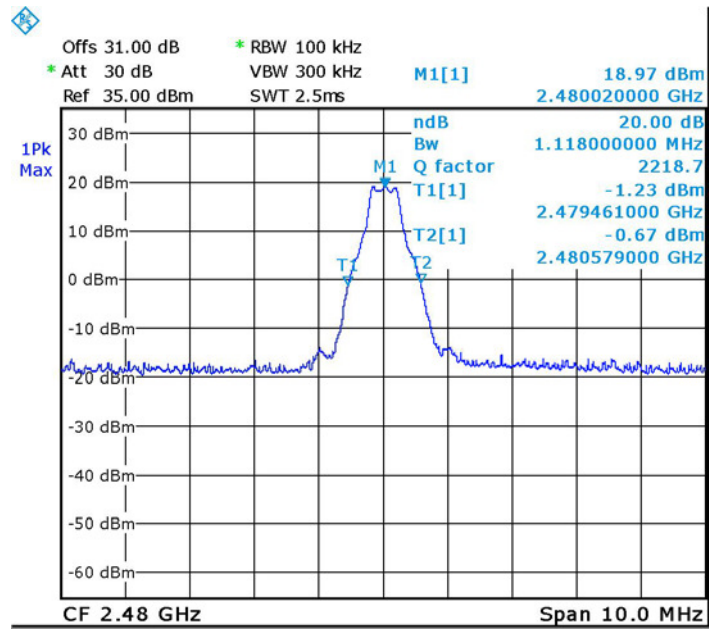
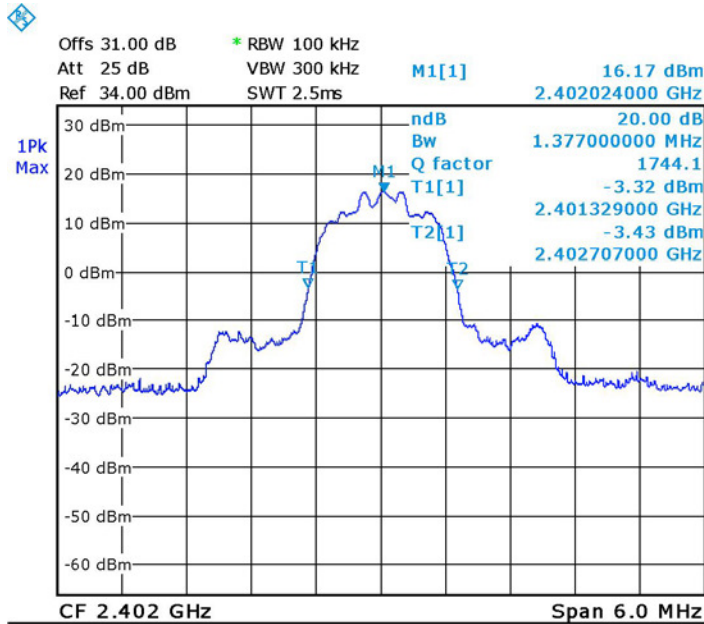

Figure 18. 2441 MHz - Mid Standard Modulation



Date: 2.NOV.2016 12:26:33

Figure 19. 2480- High Standard Modulation



Date: 6.NOV.2016 16:35:26

Figure 20. —2402 MHz – Low EDR Modulation

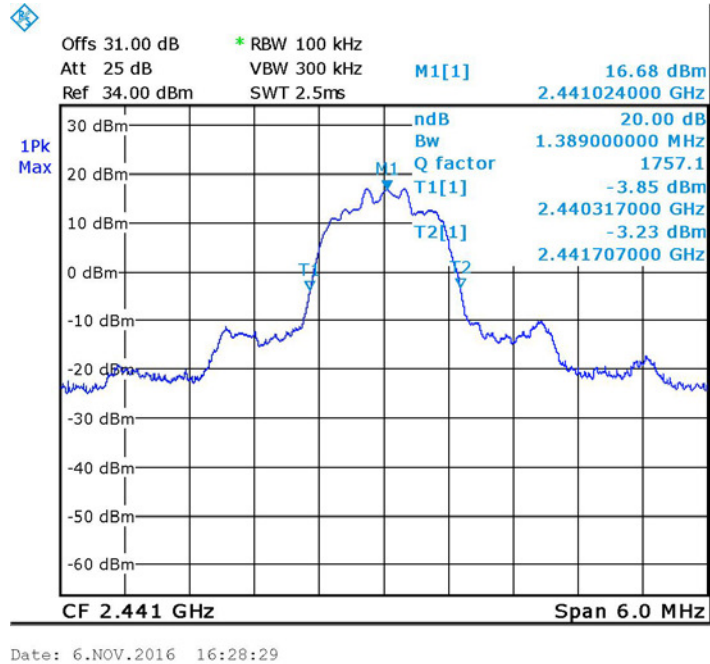

Figure 21. 2441 MHz - Mid EDR Modulation

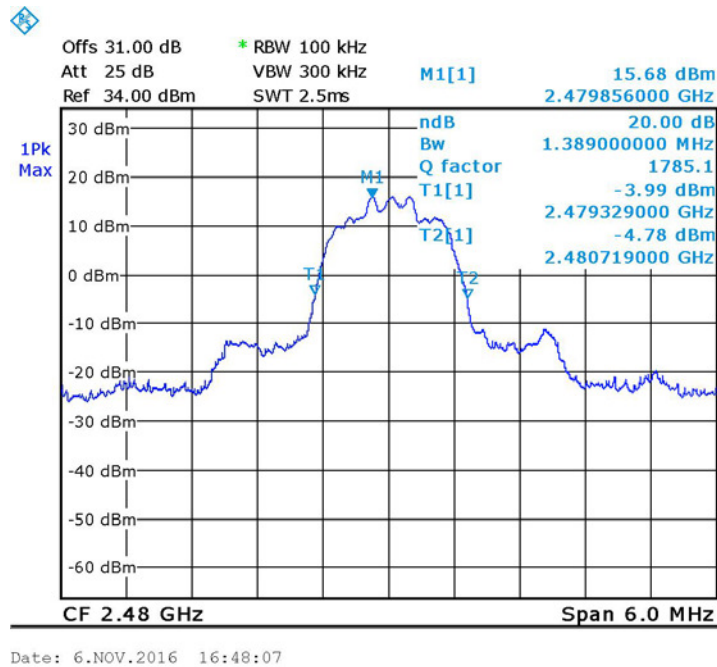

Figure 22. 2480- High EDR Modulation



5.5 Test Equipment Used, 20 dB Minimum Bandwidth

Instrument	Manufacturer	Model	Serial Number	Last Calibration Date	Next Calibration Due
Spectrum Analyzer	Rodhe & Schwarz	FSL6	100194	February 29, 2016	March 1, 2017
30dB Attenuator	Bird	8304-N30DB	533	June 1, 2016	June 1, 2017

Figure 23 Test Equipment Used



6. 26dB Minimum Bandwidth

6.1 Test Specification

F.C.C. Part 15, Subpart C: section 15.247(a)
RSS Gen, Issue 4: 2014, Section 6.6

6.2 Test Procedure

(Temperature (24°C)/ Humidity (41%RH))

The E.U.T. antenna terminal was connected to the Spectrum Analyzer through an external attenuator and an appropriate coaxial cable .The transmitter unit operated with normal modulation. The spectrum analyzer was set to the following parameters:

Span = ~ 2 to 3 times the 20 dB bandwidth, centered on a hopping channel RBW \geq 1% of the 20 dB bandwidth

Detector Function: Peak, Trace: Maximum Hold.

The E.U.T. was tested at Low, Mid and High channels.

6.3 Test Limit

N/A

6.4 Test Results

Operation Frequency (MHz)	Modulation	Bandwidth Reading (MHz)
2402	Standard	1.317
2441	Standard	1.317
2480	Standard	1.317
2402	EDR	1.485
2441	EDR	1.485
2480	EDR	1.497

Figure 24 Test Results

JUDGEMENT: Passed

For additional information see *Figure 25 to Figure 30*.

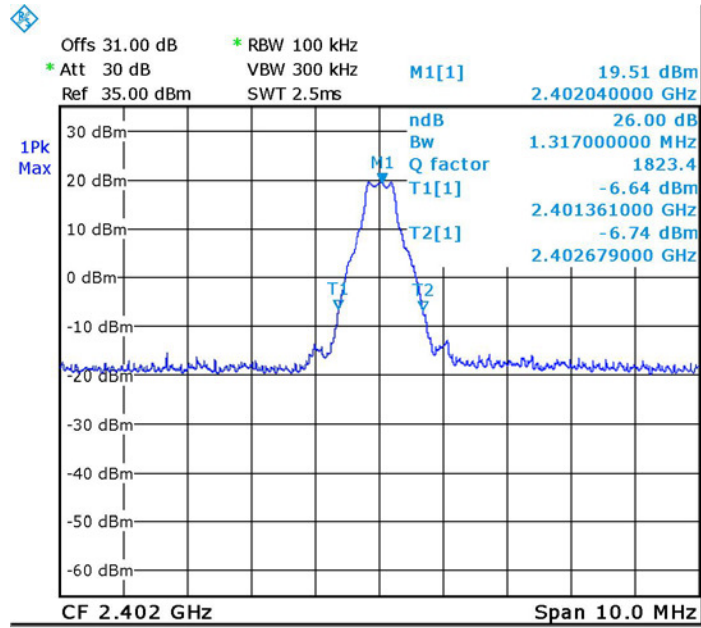

Date: 2.NOV.2016 12:45:10

Figure 25. —2402 MHz - Low Standard Modulation

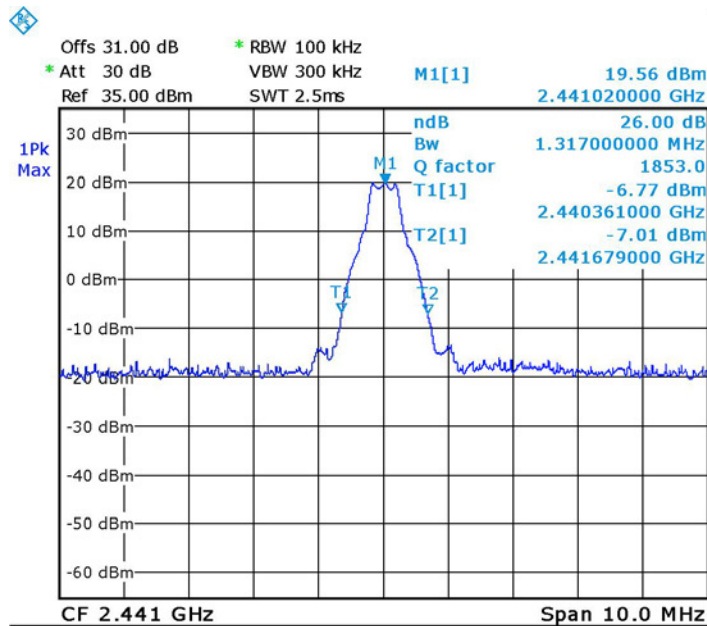

Date: 2.NOV.2016 12:33:09

Figure 26. 2441 MHz - Mid Standard Modulation

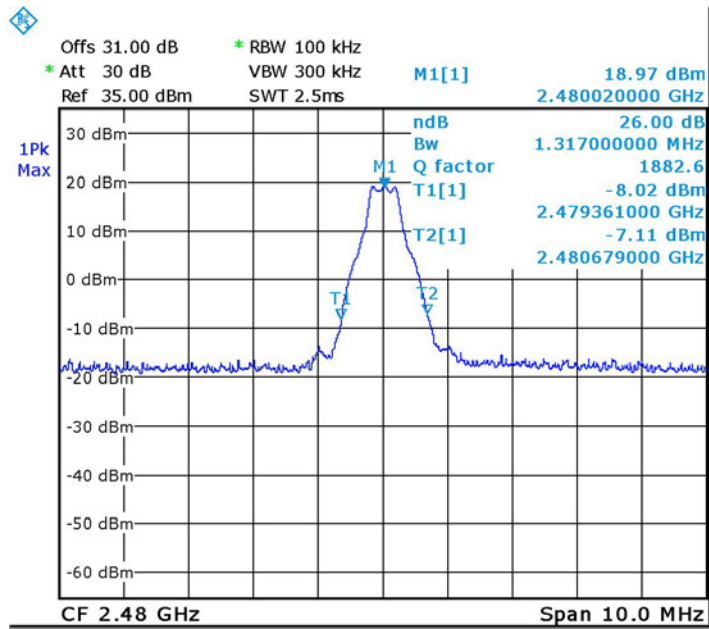

Date: 2.NOV.2016 12:29:09

Figure 27. 2480- High Standard Modulation

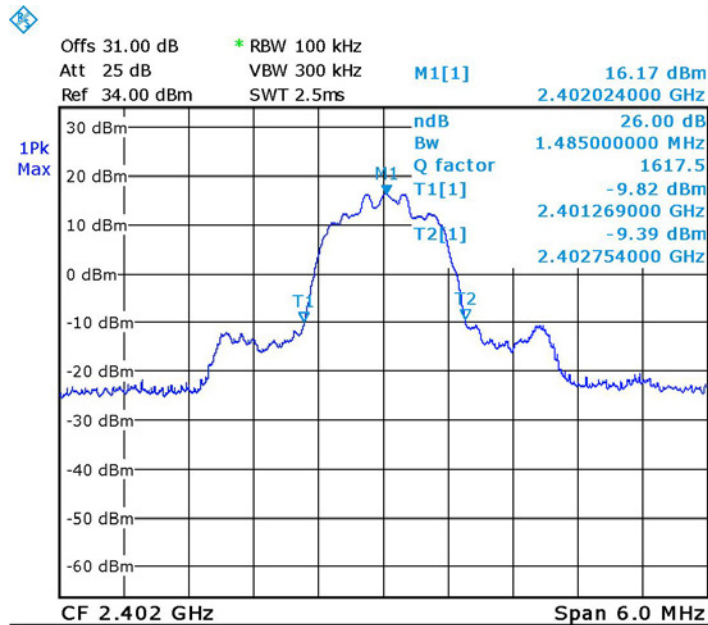

Date: 6.NOV.2016 16:36:14

Figure 28. —2402 MHz - Low EDR Modulation

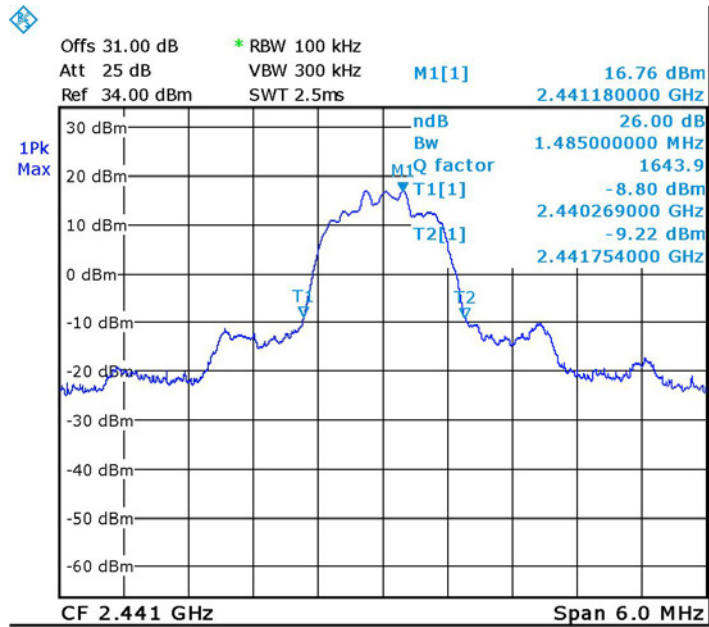

Date: 6.NOV.2016 16:29:54

Figure 29. 2441 MHz - Mid EDR Modulation

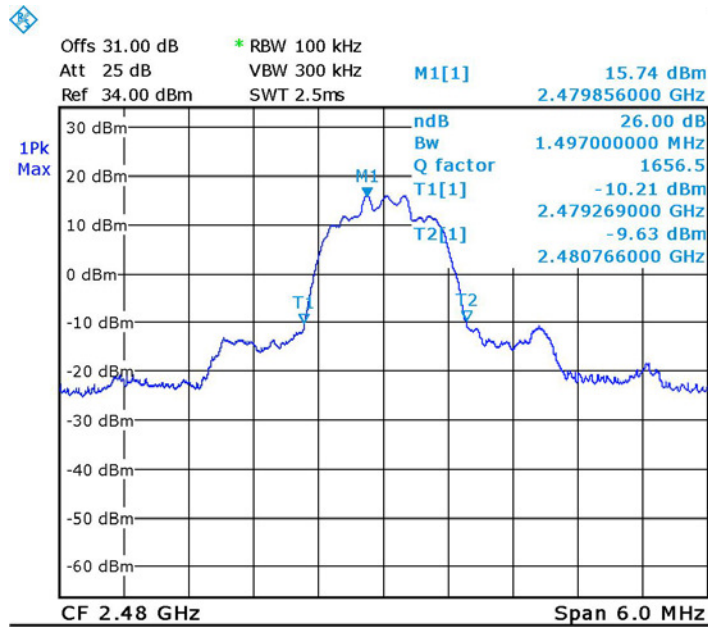

Date: 6.NOV.2016 16:55:56

Figure 30. 2480- High EDR Modulation



6.5 Test Equipment Used, 26 dB Minimum Bandwidth

Instrument	Manufacturer	Model	Serial Number	Last Calibration Date	Next Calibration Due
Spectrum Analyzer	Rodhe & Schwarz	FSL6	100194	February 29, 2016	March 1, 2017
30dB Attenuator	Bird	8304-N30DB	533	June 1, 2016	June 1, 2017

Figure 31 Test Equipment Used



7. Number of Hopping Frequencies

7.1 Test Specification

F.C.C. Part 15, Subpart C, Section 15.247(a)(1)(iii)
RSS 247, Issue 1, Section 5.1(4)

7.2 Test Procedure

(Temperature (23°C)/ Humidity (41%RH))

The E.U.T. antenna terminal was connected to the Spectrum Analyzer through an external attenuator and an appropriate coaxial cable.

The E.U.T. was set to hopping mode.

The spectrum analyzer was set to the following parameters:

Band of Operation: 2400M-2483.5 MHz

RBW: 30 kHz, VBW: 100 kHz

Detector Function: Peak, Trace: Maximum Hold

7.3 Test Limit

Frequency hopping systems in the 2400-2483.5 MHz band shall use at least 15 channels.

7.4 Test Results

Number of Hopping Frequencies	Specification
79	≥ 75

Figure 32 Test Results

JUDGEMENT: Passed

For additional information see *Figure 33* to *Figure 40*.



Number of Hopping Frequencies

E.U.T Description Bluetooth Communication System
for Motorcycles
Type scala rider FREECOM2
Serial Number: Not designated

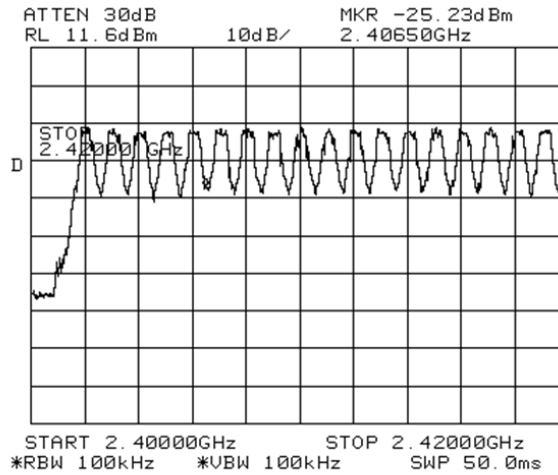

Figure 33. Number of Channels Standard Modulation



Number of Hopping Frequencies

E.U.T Description	Bluetooth Communication System for Motorcycles
Type	scala rider FREECOM2
Serial Number:	Not designated

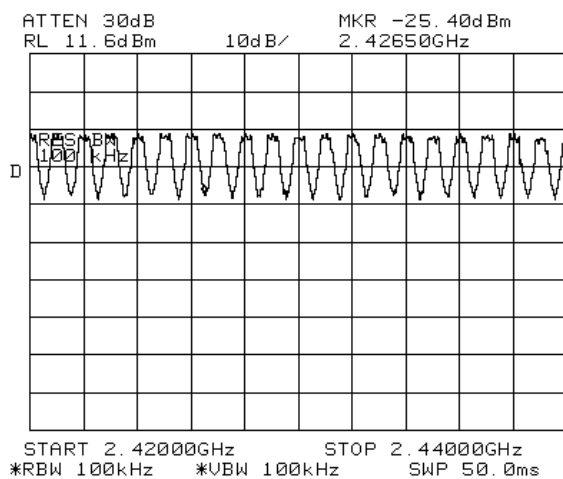

Figure 34. Number of Channels Standard Modulation



Number of Hopping Frequencies

E.U.T Description Bluetooth Communication System
for Motorcycles
Type scala rider FREECOM2
Serial Number: Not designated

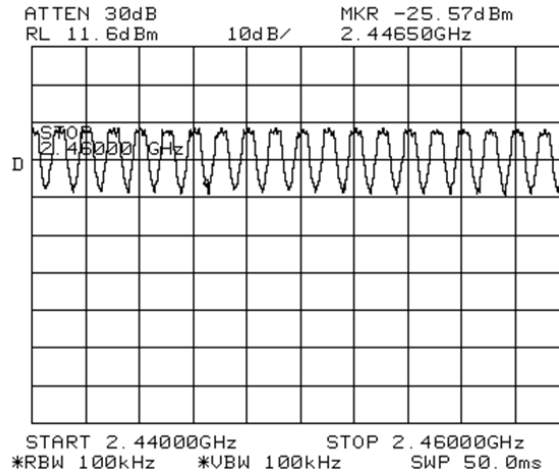

Figure 35. Number of Channels Standard Modulation



Number of Hopping Frequencies

E.U.T Description Bluetooth Communication System
for Motorcycles
Type scala rider FREECOM2
Serial Number: Not designated

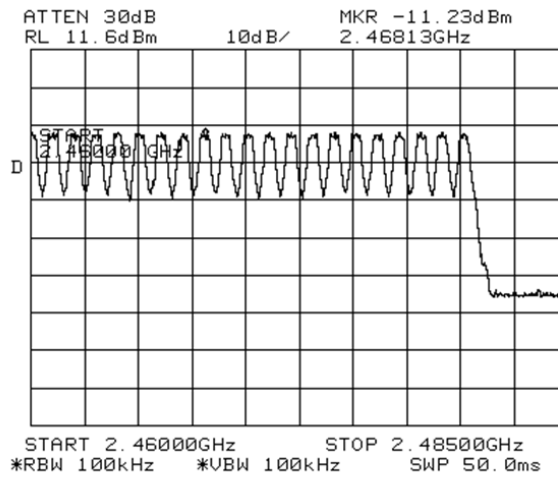

Figure 36. Number of Channels Standard Modulation



Number of Hopping Frequencies

E.U.T Description Bluetooth Communication System
for Motorcycles
Type scala rider FREECOM2
Serial Number: Not designated

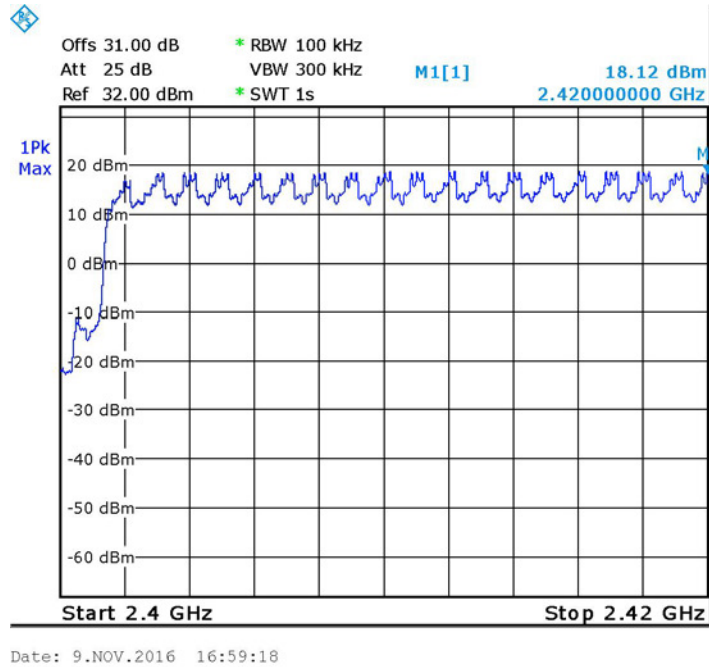

Figure 37. Number of Channels EDR Modulation



Number of Hopping Frequencies

E.U.T Description Bluetooth Communication System
for Motorcycles
Type scala rider FREECOM2
Serial Number: Not designated

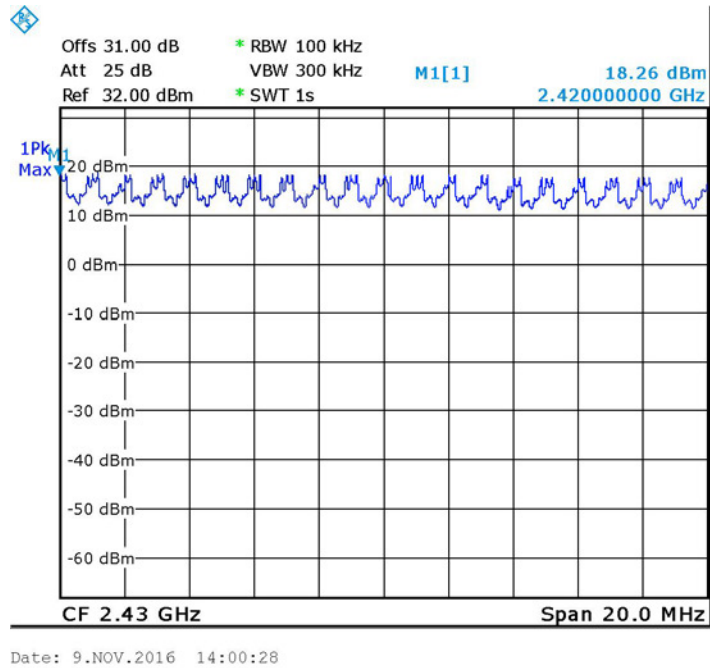
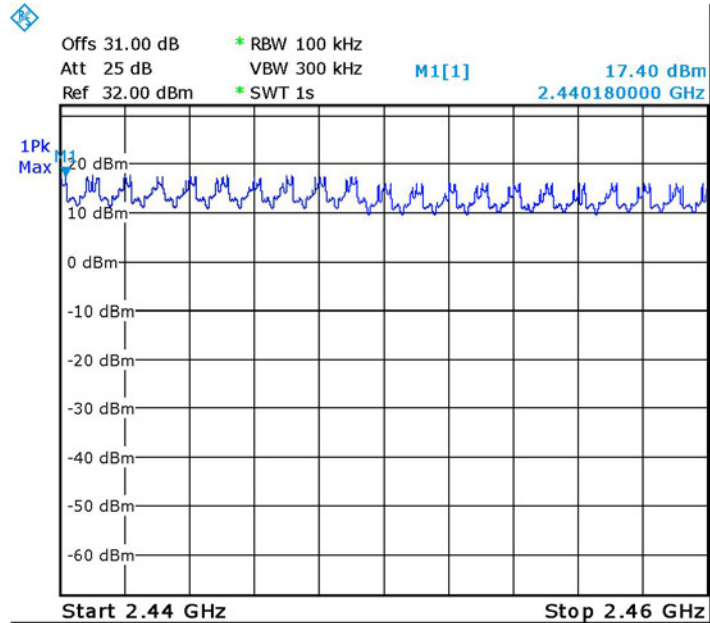

Figure 38. Number of Channels EDR Modulation



Number of Hopping Frequencies

E.U.T Description Bluetooth Communication System
for Motorcycles
Type scala rider FREECOM2
Serial Number: Not designated



Date: 9.NOV.2016 14:23:56

Figure 39. Number of Channels EDR Modulation



Number of Hopping Frequencies

E.U.T Description Bluetooth Communication System
for Motorcycles
Type scala rider FREECOM2
Serial Number: Not designated

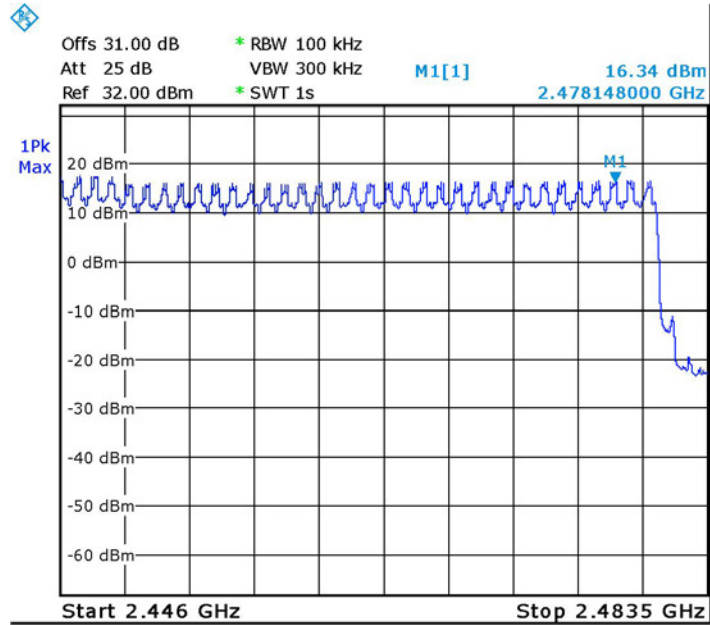

Date: 9.NOV.2016 15:23:33

Figure 40. Number of Channels EDR Modulation



7.5 Test Equipment Used, Number of Hopping Frequencies

Instrument	Manufacturer	Model	Serial Number	Last Calibration Date	Next Calibration Due
Spectrum Analyzer	Rodhe & Schwarz	FSL6	100194	February 29, 2016	March 1, 2017
Spectrum Analyzer	HP	8564E	3442A00275	February 29, 2016	March 10, 2017
30dB Attenuator	Bird	8304-N30DB	533	June 1, 2016	June 1, 2017

Figure 41 Test Equipment Used



8. Channel Frequency Separation

8.1 Test Specification

FCC Part 15, Subpart C, Section 15.247(a) (1)

RSS 247, Issue 1, Section 5.1(2)

8.2 Test Procedure

(Temperature (25°C)/ Humidity (42%RH))

The E.U.T. antenna terminal was connected to the Spectrum Analyzer through an external attenuator and an appropriate coaxial cable.

The E.U.T. was set to hopping mode.

The spectrum analyzer was set to the following parameters:

Span = wide enough to capture two adjacent channels, RBW \geq 1% of the span

Detector Function: Peak, Trace: Maximum Hold.

8.3 Test Limit

Frequency hopping systems shall have hopping channel carrier frequencies separated by a minimum of 25 kHz or the 20 dB bandwidth of the hopping channel, whichever is greater. Alternatively, frequency hopping systems operating in the 2400-2483.5 MHz band may have hopping channel carrier frequencies that are separated by 25 kHz or two-thirds of the 20 dB bandwidth of the hopping channel, whichever is greater, provided the systems operate with an output power no greater than 125 mW.

8.4 Test Results

Channel Frequency Separation	Specification	Modulation	Margin
(MHz)	(MHz)		(kHz)
1.010	>0.745	Standard	-251.3
1.038	>0.926	EDR	-112.0

Figure 42 Test Results

JUDGEMENT: Passed by 112.0 kHz

For additional information see *Figure 43* and *Figure 44*.



Channel Frequency Separation

E.U.T Description Bluetooth Communication System for Motorcycles
Type scala rider FREECOM2
Serial Number: Not designated

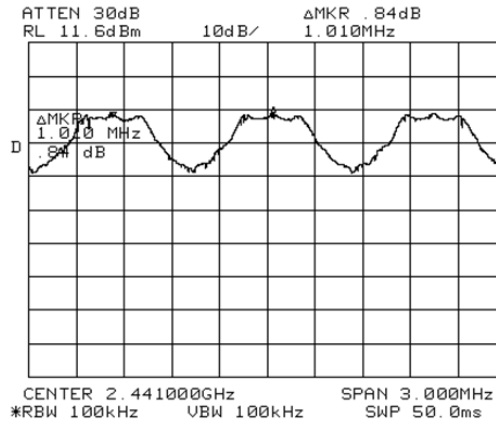

Figure 43. Channel Frequency Separation Standard Modulation

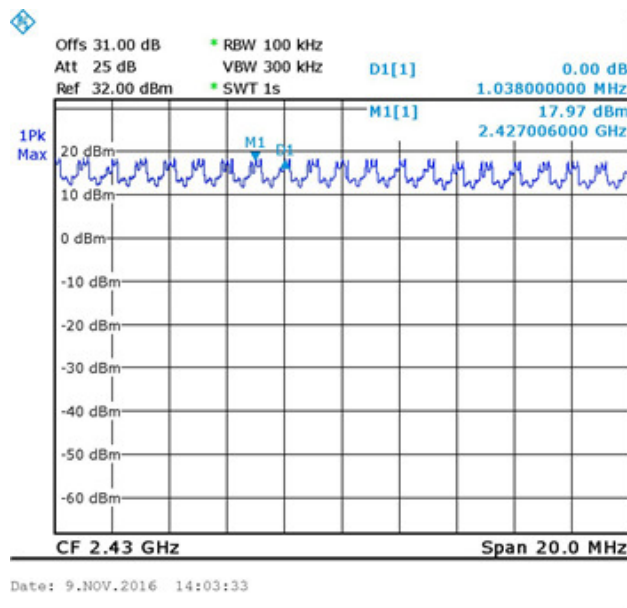

Figure 44. Channel Frequency Separation EDR Modulation



8.5 Test Equipment Used, Channel Frequency Separation Test

Instrument	Manufacturer	Model	Serial Number	Last Calibration Date	Next Calibration Due
Spectrum Analyzer	Rodhe & Schwarz	FSL6	100194	February 29, 2016	March 1, 2017
Spectrum Analyzer	HP	8564E	3442A00275	February 29, 2016	March 10, 2017
30dB Attenuator	Bird	8304-N30DB	533	June 1, 2016	June 1, 2017

Figure 45 Test Equipment Used



9. Peak Output Power

9.1 Test Specification

F.C.C. Part 15, Subpart C, Section 15.247(b)(1)
RSS 247, Issue 1, Section 5.4(2)

9.2 Test Procedure

(Temperature (23°C)/ Humidity (40%RH))

The E.U.T. antenna terminal was connected to the Spectrum Analyzer through an external attenuator and an appropriate coaxial cable (total loss= 30.5dB).

The spectrum analyzer was set to the following parameters:

Span = ~5 times the 20 dB bandwidth, centered on a hopping channel RBW \geq of the 20 dB bandwidth of the emission being measured

Detector Function: Peak, Trace: Maximum Hold.

The E.U.T. was tested at the low (2402MHz), mid (2441MHz) and high (2480MHz) channels with modulation.

9.3 Test Limit

The maximum peak conducted output power of the intentional radiator shall not exceed the following:

For frequency hopping systems operating in the 2400-2483.5 MHz band employing at least 75 non-overlapping hopping channels: 1 watt.

For all other frequency hopping systems in the 2400-2483.5 MHz band: 0.125 W
(The limits above applies to antenna gain until 6dBi).

9.4 Test Results

Operation Frequency	Modulation	Power (dBm)	Power (mW)	Specification (mW)	Margin (mW)
(MHz)		(dBm)	(mW)	(mW)	(mW)
2402	Standard	19.95	98.86	125.00	26.14
2441	Standard	19.99	99.77	125.00	25.23
2480	Standard	19.54	89.95	125.00	35.05
2402	EDR	18.14	65.16	125.00	59.84
2441	EDR	18.33	68.08	125.00	56.92
2480	EDR	17.52	56.49	125.00	68.51

Figure 46 Radiated Power Output Test Results

JUDGEMENT: Passed by 25.23mW

For additional information see *Figure 47* to *Figure 52*.



Peak Output Power

E.U.T Description Bluetooth Communication System for Motorcycles
Type scala rider FREECOM2
Serial Number: Not designated

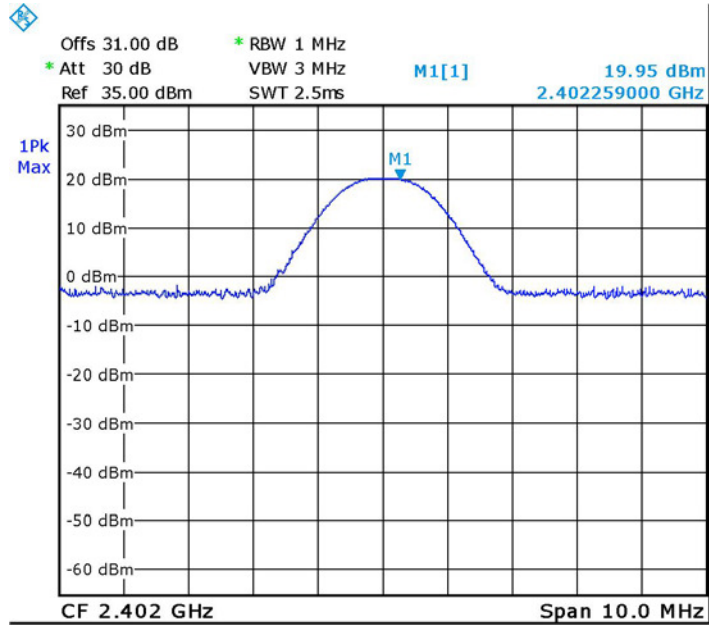

Date: 2.NOV.2016 12:07:50

Figure 47 — 2402 MHz - Low Standard Modulation

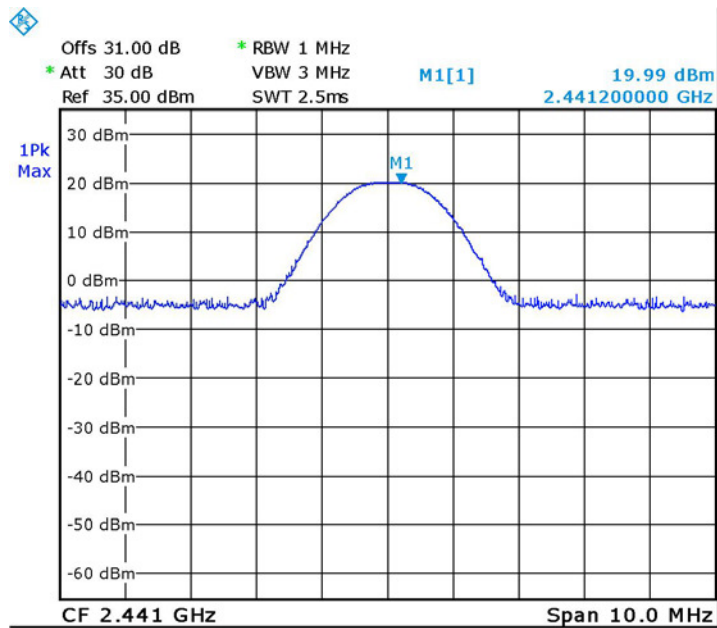

Date: 2.NOV.2016 12:11:20

Figure 48 — 2441 - Mid Standard Modulation



Peak Output Power

E.U.T Description Bluetooth Communication System for Motorcycles
Type scala rider FREECOM2
Serial Number: Not designated

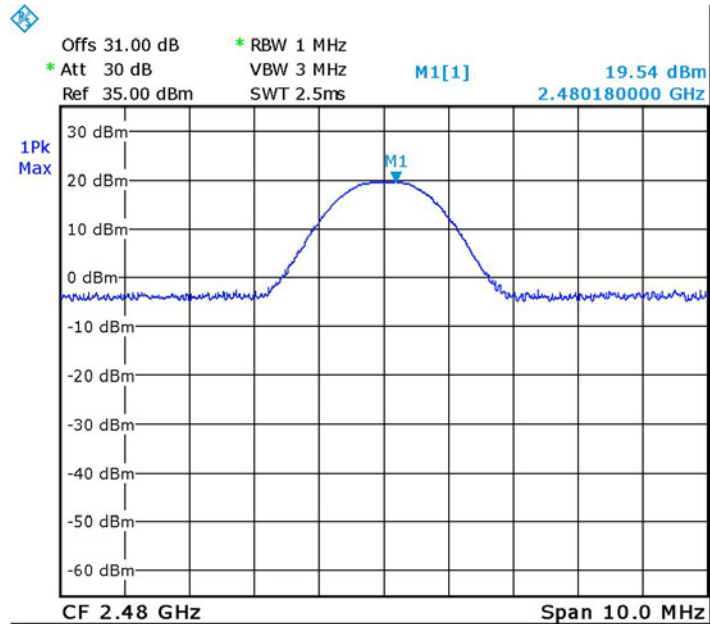

Date: 2.NOV.2016 12:18:42

Figure 49 — 2480MHz - High Standard Modulation

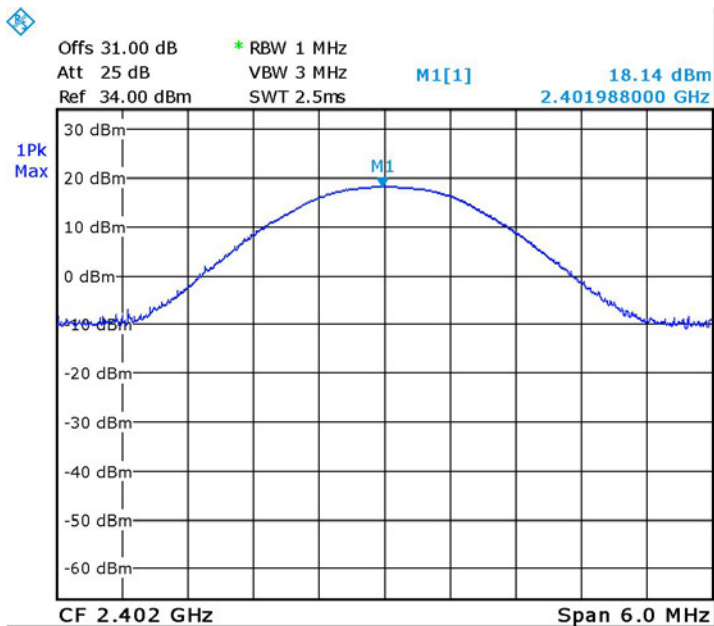

Date: 6.NOV.2016 16:39:35

Figure 50 — 2402 MHz - Low EDR Modulation



Peak Output Power

E.U.T Description Bluetooth Communication System for Motorcycles
Type scala rider FREECOM2
Serial Number: Not designated

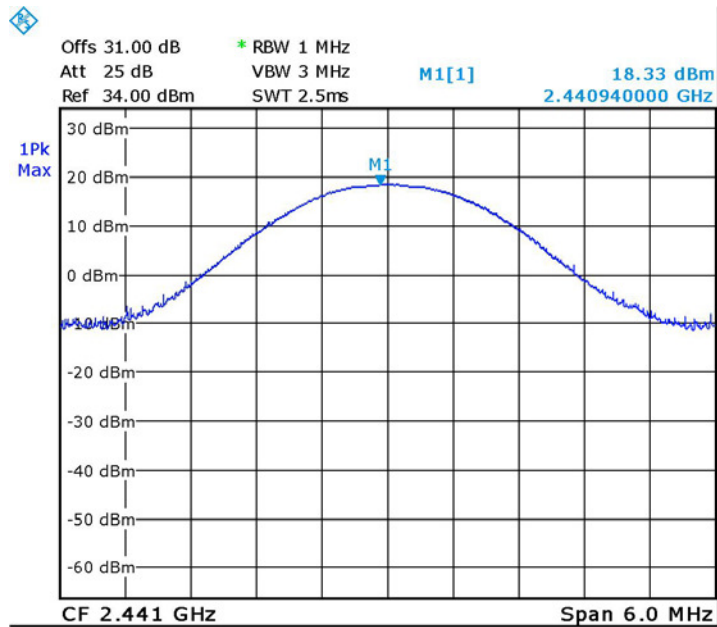

Date: 6.NOV.2016 16:32:31

Figure 51 — 2441 - Mid EDR Modulation

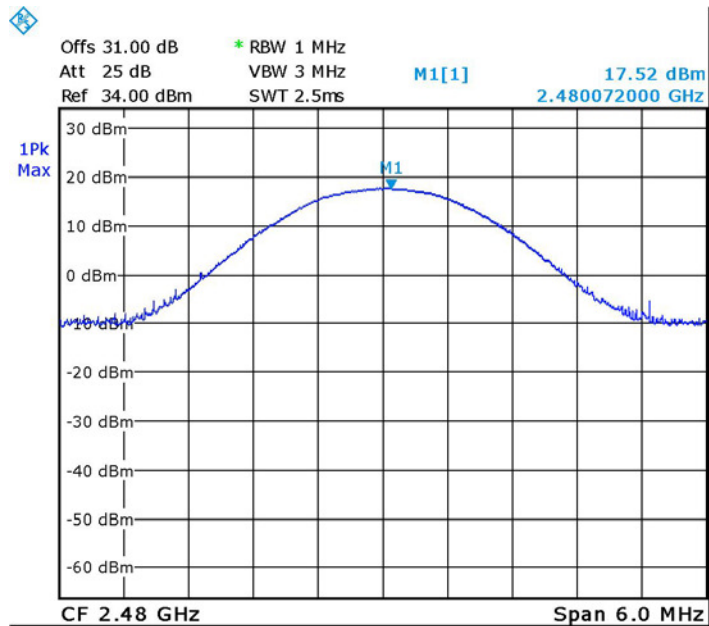

Date: 6.NOV.2016 17:00:03

Figure 52 — 2480MHz - High EDR Modulation



9.5 Test Equipment Used, Radiated Maximum Power Output

Instrument	Manufacturer	Model	Serial Number	Last Calibration Date	Next Calibration Due
Spectrum Analyzer	Rodhe & Schwarz	FSL6	100194	February 29, 2016	March 1, 2017
30dB Attenuator	Bird	8304-N30DB	533	June 1, 2016	June 1, 2017

Figure 53 Test Equipment Used



10. Dwell Time on Each Channel

10.1 Test Specification

FCC Part 15, Subpart C, Section 15.247(a)(1)(iii)
RSS-247, Issue 1, Section 5.1(4)

10.2 Test Procedure

(Temperature (°25C)/ Humidity (40%RH))

The E.U.T. antenna terminal was connected to the Spectrum Analyzer through an external attenuator and an appropriate coaxial cable.

The spectrum analyzer was set to the following parameters:

Span = zero span, centered on a hopping channel, RBW \geq 1MHz

Detector Function: Peak, Trace: Maximum Hold.

10.3 Test Limit

The average time of occupancy on any channel shall not be greater than 0.4 seconds within a period of 0.4 seconds multiplied by the number of hopping channels employed.

10.4 Test Results

JUDGEMENT: Passed

The E.U.T met the requirements of the FCC Part 15, Section 15.247(a)(1)(iii) and RSS-247, Issue 1, Section 5.1(4).

Additional information of the results is given in *Figure 54* to *Figure 57*.

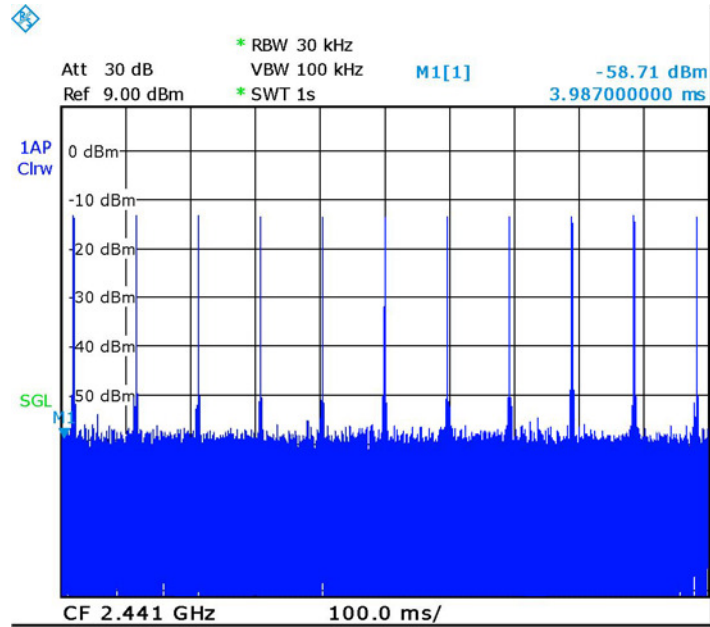

Date: 6.NOV.2016 11:41:51

Figure 54 — Number of bursts in 1 sec = 11 standard modulation

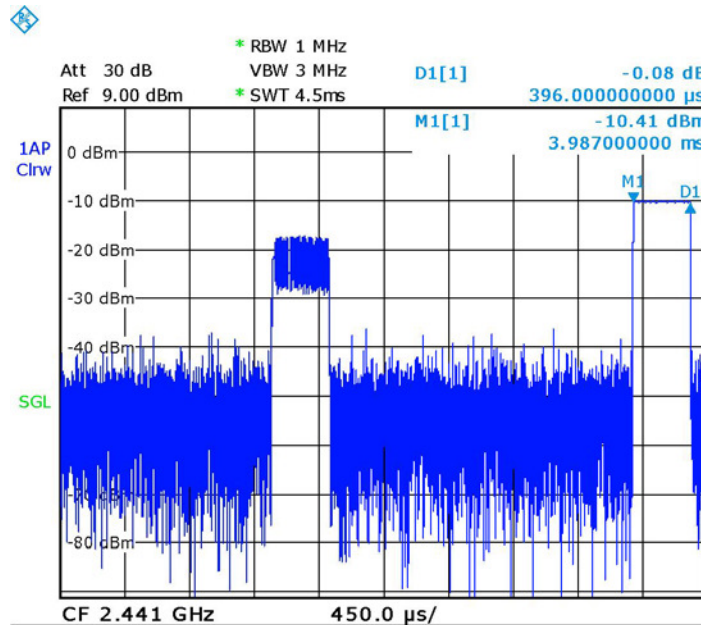

Date: 6.NOV.2016 11:29:42

Figure 55 — Burst Duration = .396mS standard modulation
DWELL TIME = $0.396m * 11 * 31.6 = 137.65msec = 0.14s < 0.4s$

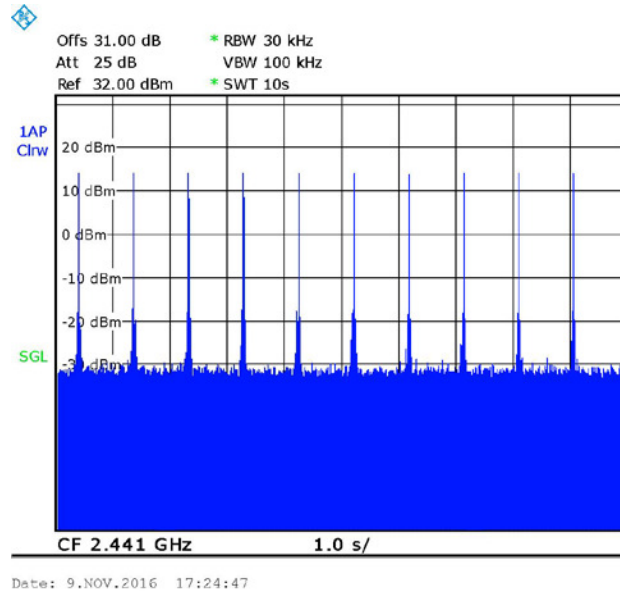

Figure 56 — Number of Bursts in 10 sec=10 EDR modulation

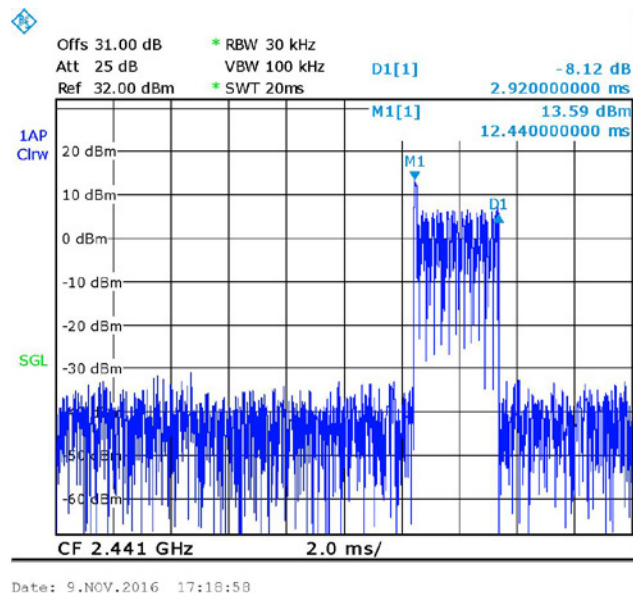

Figure 57 — Burst Duration =2.92ms EDR modulation

$$\text{DWELL TIME} = 2.92\text{m} * 1 * 31.6 = 92.27\text{msec} = 0.09 < 0.4\text{s}$$



10.5 Test Equipment Used, Dwell Time on Each Channel

Instrument	Manufacturer	Model	Serial Number	Last Calibration Date	Next Calibration Due
Spectrum Analyzer	HP	8564E	3442A00275	February 29, 2016	March 1, 2017
30dB Attenuator	Bird	8304-N30DB	533	June 1, 2016	June 1, 2017

Figure 58 Test Equipment Used

11. Band Edge

11.1 Test Specification

FCC Part 15, Subpart C, Section 15.247(d)

RSS-247, Issue 1, Section 5.5

11.2 Test Procedure

(Temperature (23°C)/ Humidity (41%RH))

The E.U.T. antenna terminal was connected to the Spectrum Analyzer through an external attenuator and an appropriate coaxial cable.

The transmitter unit operated in 2 modes: hopping enabled and hopping disabled.

The RBW was set to 100 kHz.

The EMI receiver was adjusted to the transmission channel at the maximum level.

The display line was set to 20 dBc and the EMC analyzer was set to the band edge frequencies.

The E.U.T. was tested at the lower and the upper channels.

11.3 Test Limit

In any 100 kHz bandwidth outside the frequency band in which the spread spectrum or digitally modulated intentional radiator is operating, the radio frequency power that is produced by the intentional radiator shall be at least 20dB below that in the 100 kHz bandwidth within the band that contains the highest level of the desired power.

11.4 Test Results

Mode	Operation Frequency (MHz)	Modulation Type	Band Edge Frequency (MHz)	Spectrum Level (dBm)	Limit (dBm)	Margin (dB)
Hopping	Low	Standard	2399.78	-18.36	-0.5	-17.9
	High	Standard	2483.51	-20.35	-0.5	-19.9
Non-Hopping	Low	Standard	2400.	-18.64	-0.5	-18.1
	High	Standard	2483.5	-19.90	-0.5	-19.4
Hopping	Low	EDR	2400.0	-23.17	-2.69	-20.5
	High	EDR	2483.52	-23.50	-4.0	-19.5
Non-Hopping	Low	EDR	2399.77	-22.84	-1.86	-21.0
	High	EDR	2483.5	-24.22	-2.48	-21.7

Figure 59 Band Edge Test Results

JUDGEMENT: Passed by 17.9 dB

For additional information see *Figure 60 to Figure 67.*

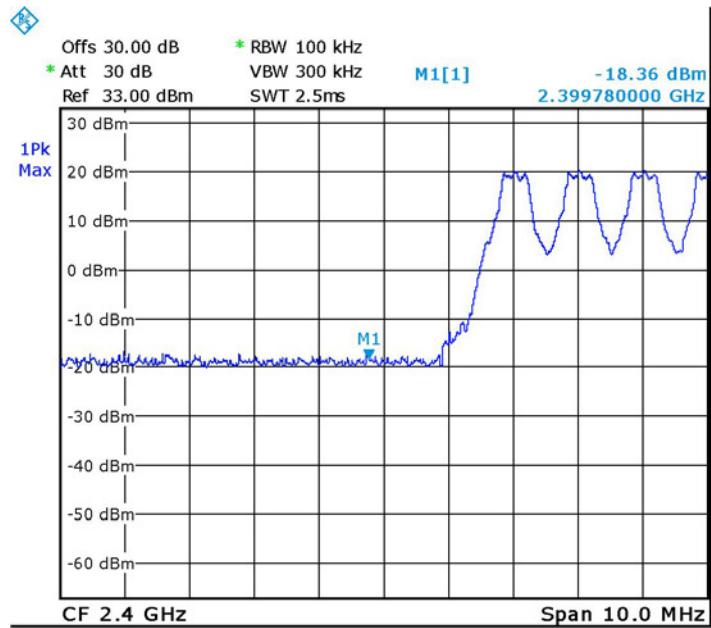

Date: 6.NOV.2016 12:55:59

Figure 60 — Hopping - Low Standard Modulation

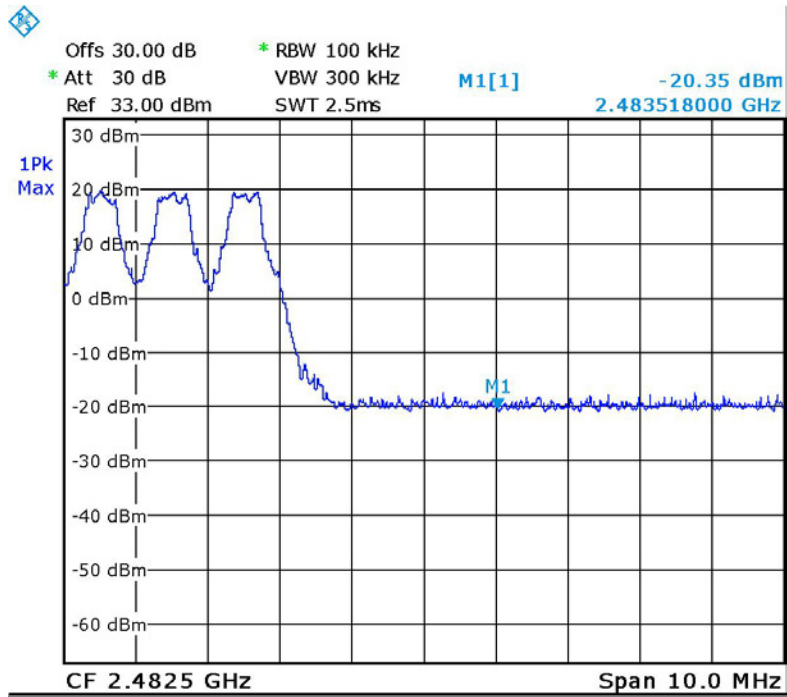

Date: 6.NOV.2016 12:47:24

Figure 61 — Hopping - High Standard Modulation

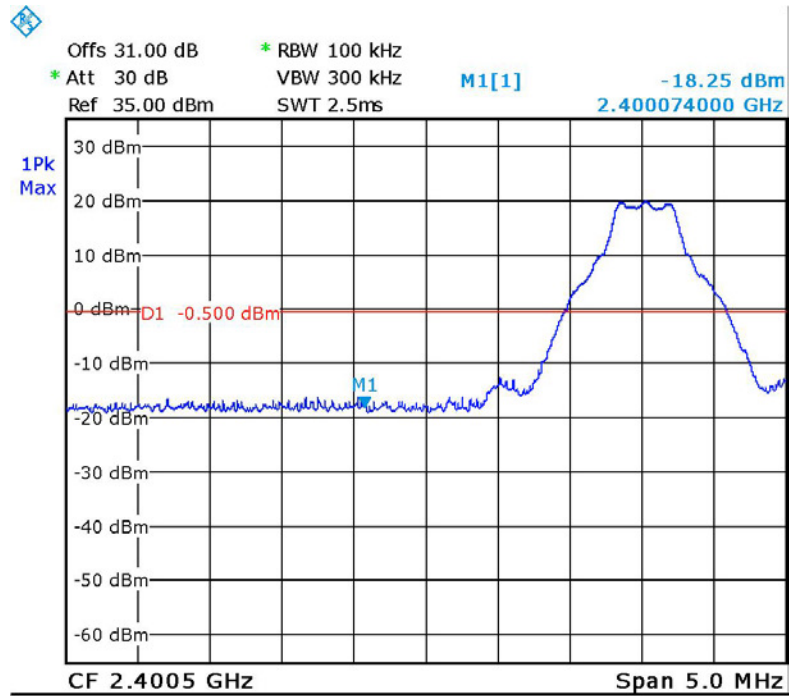

Date: 2.NOV.2016 13:04:31

Figure 62 — Non-Hopping - Low Standard Modulation

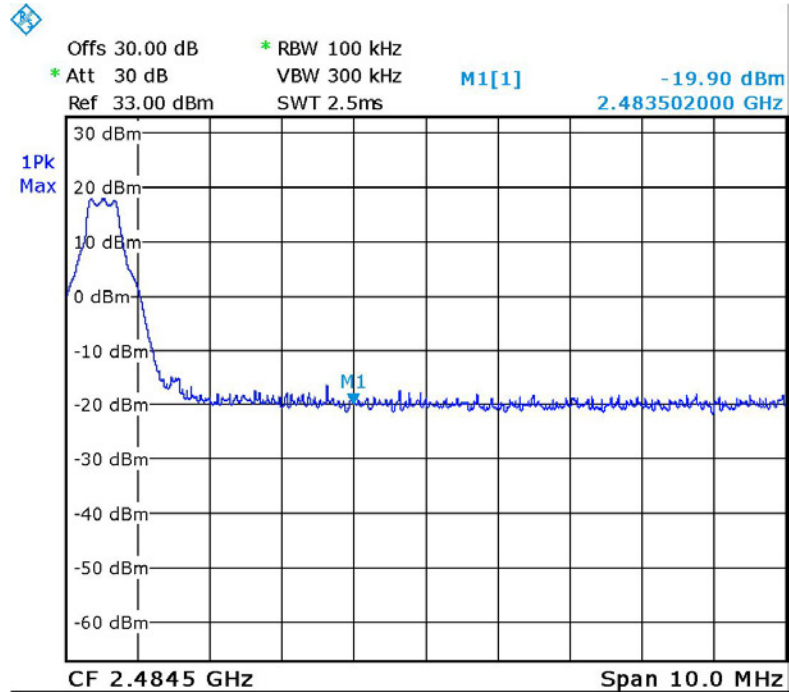

Date: 6.NOV.2016 13:02:51

Figure 63 — Non-Hopping – High Standard Modulation

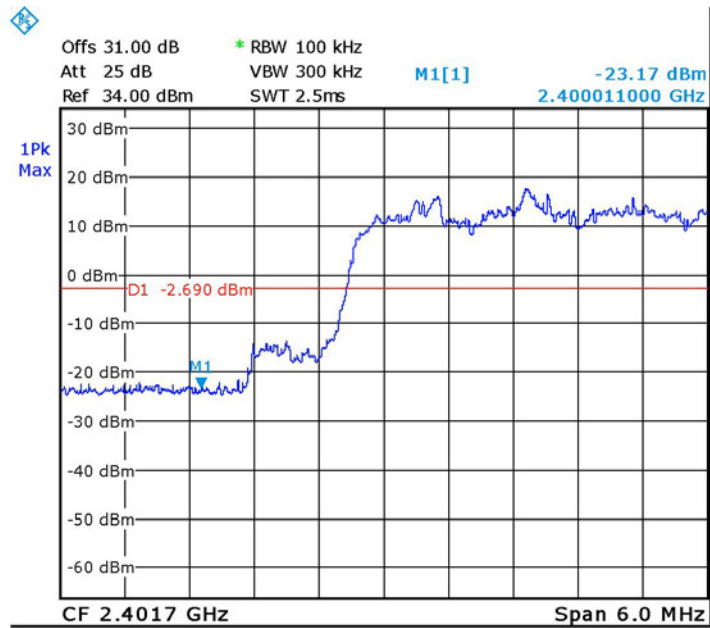

Date: 6.NOV.2016 17:27:52

Figure 64 — Hopping - Low EDR Modulation

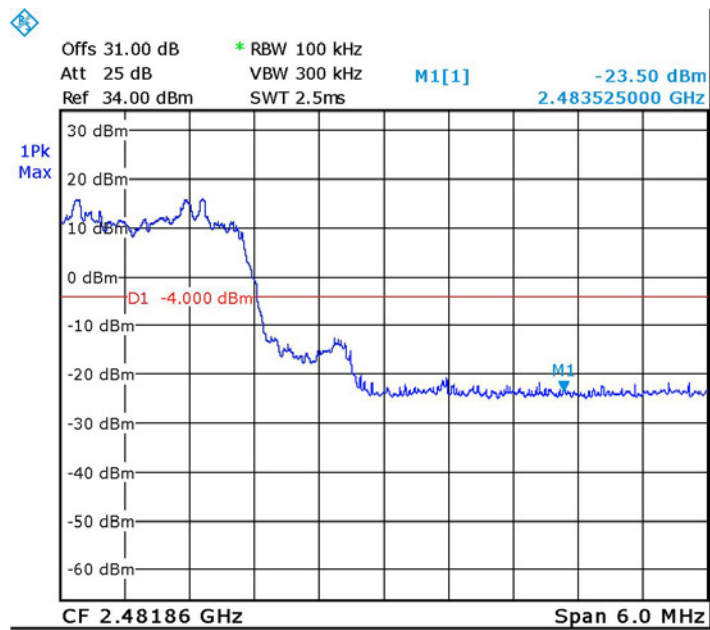

Date: 6.NOV.2016 17:38:39

Figure 65 — Hopping - High EDR Modulation

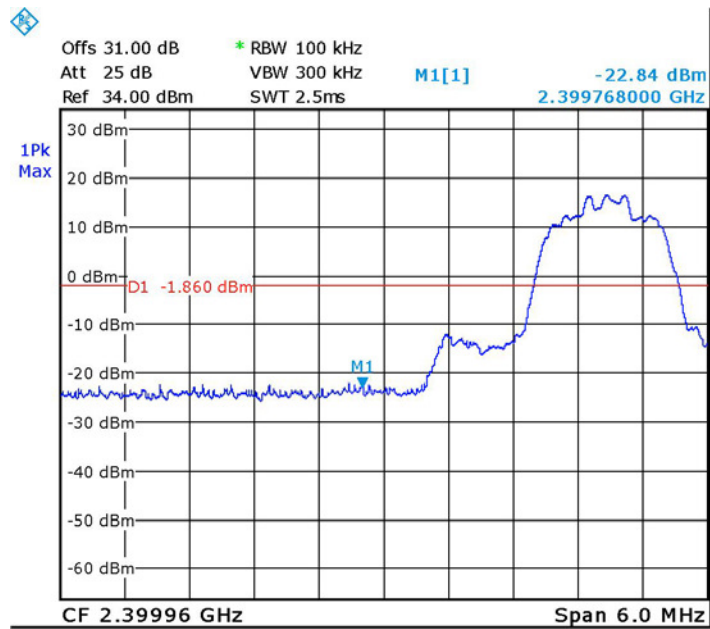

Date: 6.NOV.2016 16:45:37

Figure 66 — Non-Hopping - Low EDR Modulation

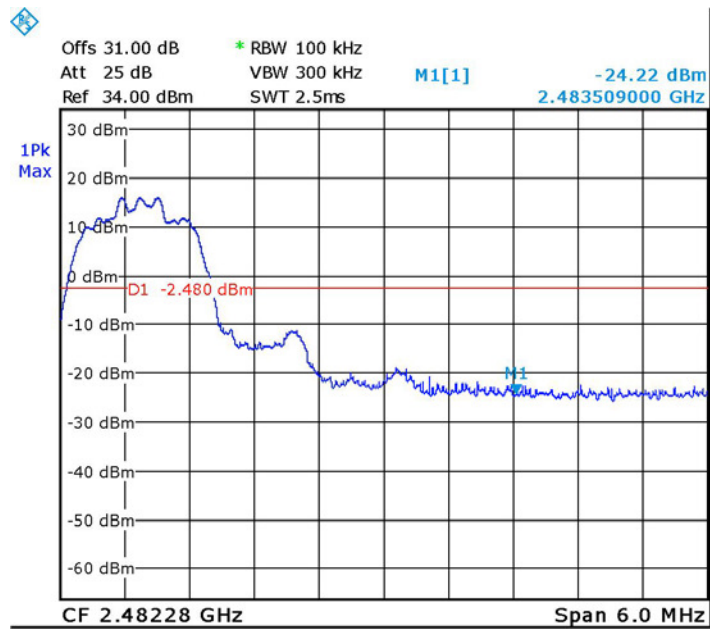

Date: 6.NOV.2016 17:04:47

Figure 67 — Non-Hopping – High EDR Modulation



11.5 Test Equipment Used, Band Edge Spectrum

Instrument	Manufacturer	Model	Serial Number	Last Calibration Date	Next Calibration Due
Spectrum Analyzer	Rodhe & Schwarz	FSL6	100194	February 29, 2016	March 1, 2017
30dB Attenuator	Bird	8304-N30DB	533	June 1, 2016	June 1, 2017

Figure 68 Test Equipment Used



12. Emissions in Non-Restricted Frequency Bands

12.1 Test Specification

FCC Part 15, Subpart C, Section 247(d)
RSS 247, Issue 1, Section 5.5

12.2 Test Procedure

(Temperature (24°C)/ Humidity (41%RH))

The E.U.T. antenna terminal was connected to the Spectrum Analyzer through an external attenuator and an appropriate coaxial cable.

The frequency range 0.009-25,000.0 MHz was scanned to find other emissions that don't fall in the restricted band.

RBW was set to 100 kHz, detector set to max peak and trace to "max hold".

The E.U.T. was operated at the following frequencies: Low (2402 MHz), Mid (2441 MHz) and High (2480 MHz).

These frequencies were measured using a peak detector.

12.3 Test Limit

In any 100 kHz bandwidth outside the frequency band in which the spread spectrum or digitally modulated intentional radiator is operating, the radio frequency power that is produced by the intentional radiator shall be at least 20 dB below that in the 100 kHz bandwidth within the band that contains the highest level of the desired power.

12.4 Test Results

JUDGEMENT: Passed

The EUT met the requirements of the F.C.C. Part 15, Subpart C, Section 247 (d) and RSS 247, Issue 1, Section 5.5 specification.

For additional information see *Figure 69* to *Figure 74*.

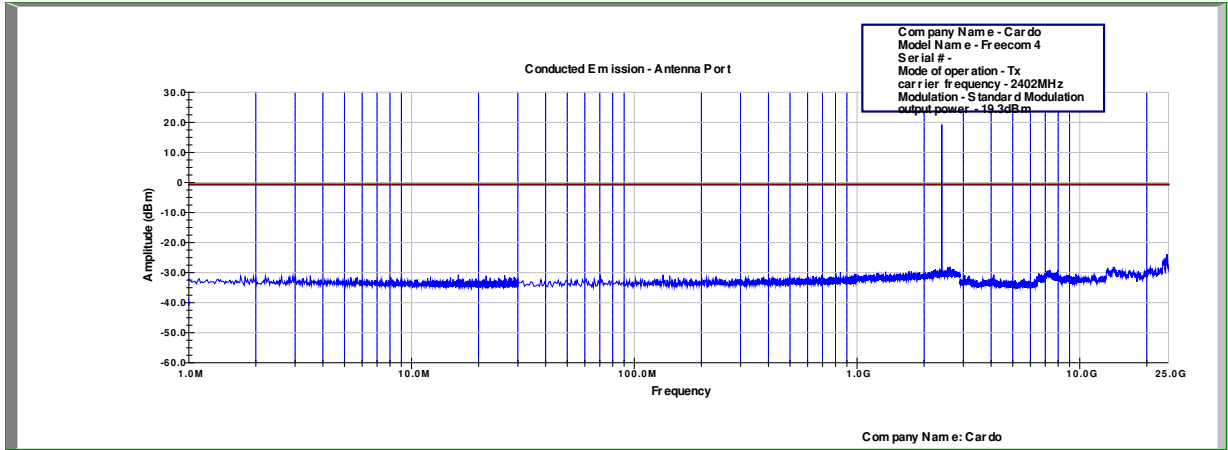

Figure 69 Conducted Spurious Emission – 2402 MHz Standard modulation

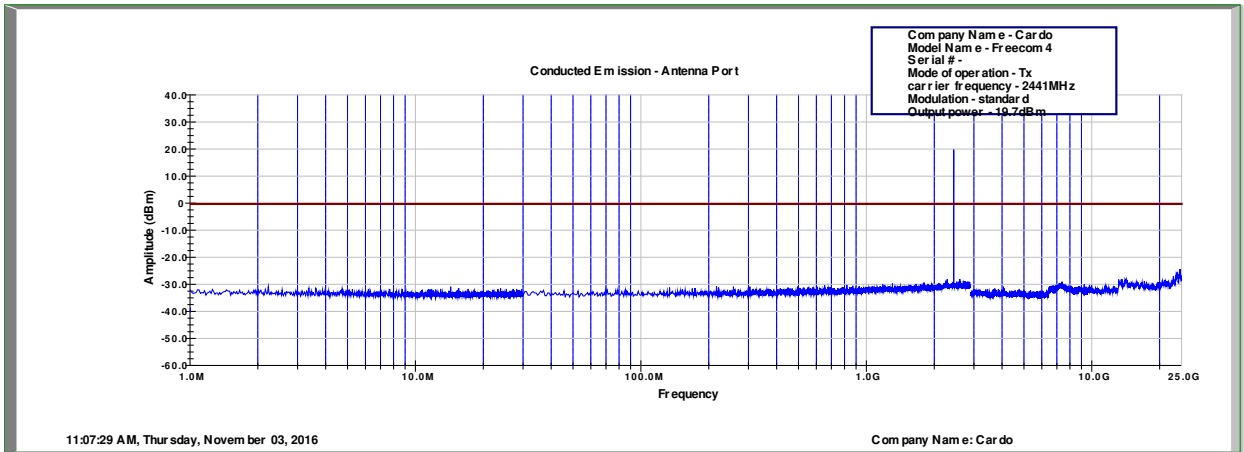

Figure 70 Conducted Spurious Emission - 2441 MHz Standard modulation

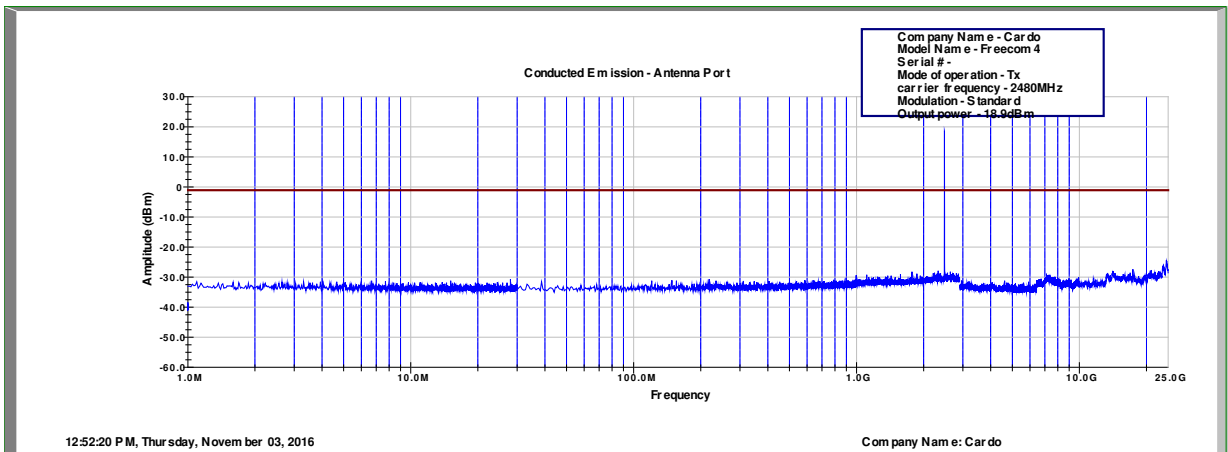

Figure 71 Conducted Spurious Emission – 2480 MHz Standard modulation

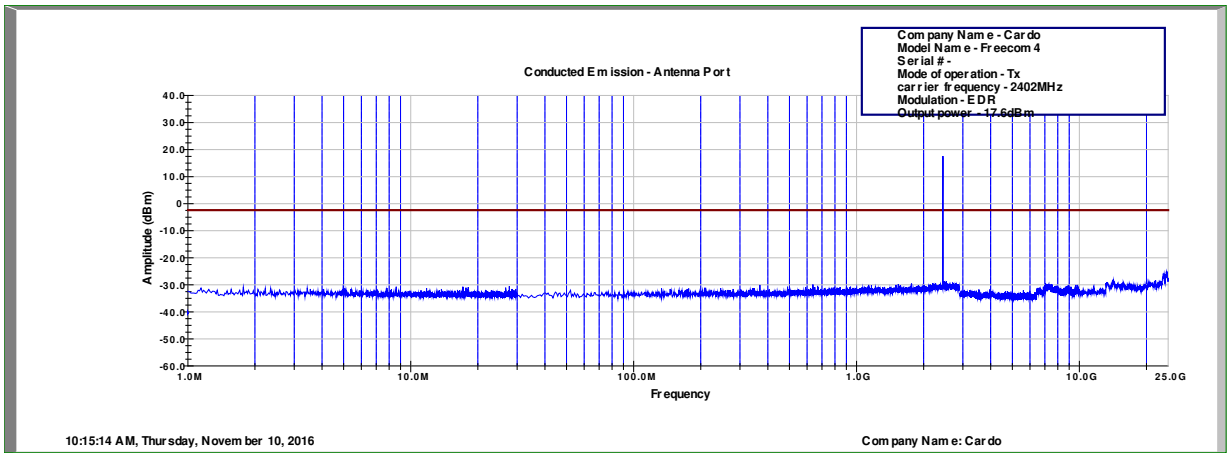

Figure 72 Conducted Spurious Emission – 2402 MHz EDR modulation

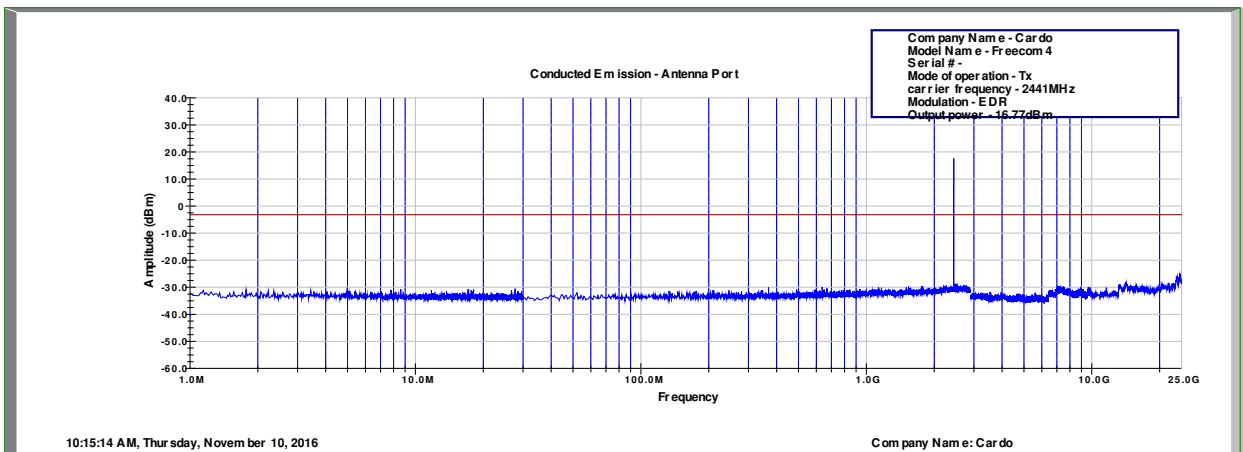

Figure 73 Conducted Spurious Emission - 2441 MHz EDR modulation

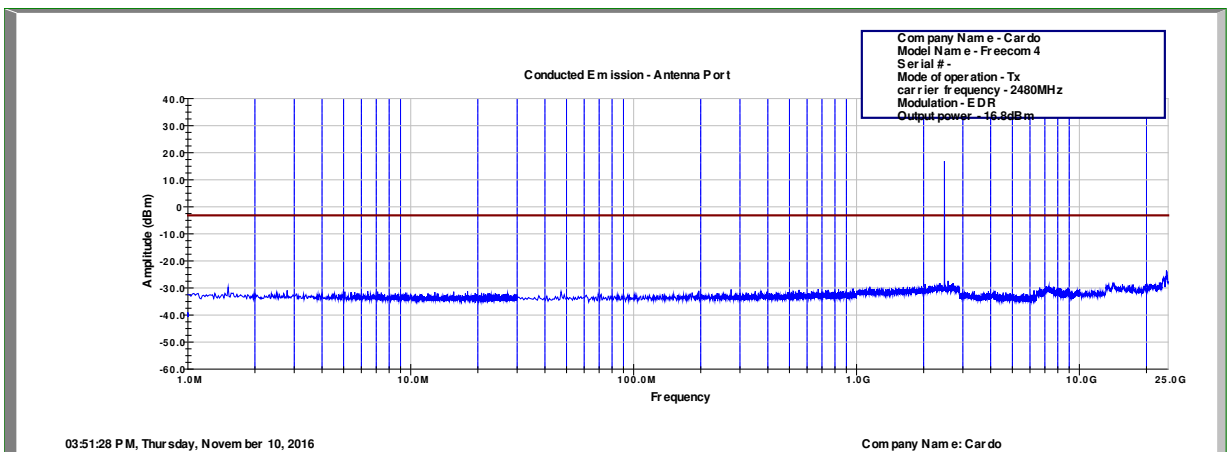

Figure 74 Conducted Spurious Emission – 2480 MHz EDR modulation



12.5 Test Equipment Used, Emissions in Non-Restricted Frequency Bands

Instrument	Manufacturer	Model	Serial Number	Last Calibration Date	Next Calibration Due
Spectrum Analyzer	Rodhe & Schwarz	FSL6	100194	February 29, 2016	March 1, 2017
30dB Attenuator	Bird	8304-N30DB	533	June 1, 2016	June 1, 2017

Figure 75 Test Equipment Used



13. Emissions in Restricted Frequency Bands

13.1 Test Specification

FCC, Part 15, Subpart C, Sections 247(d), 15.205, 15.209
RSS Gen, Issue 4: 2014 Section 8.9, 8.10

13.2 Test Procedure

(Temperature (23°C)/ Humidity (41%RH))

For measurements between 0.009MHz-30MHz:

The E.U.T was tested inside the shielded room at a distance of 3 meters and the E.U.T was placed on a non-metallic table, 1.5 meters above the ground. The frequency range 0.009MHz-30MHz was scanned. The readings were maximized by the turntable azimuth between 0-360°, and the antenna polarization. The emissions were measured at a distance of 3 meters.

For measurements between 30.0MHz-1.0GHz:

A preliminary measurement to characterize the E.U.T was performed inside the shielded room at a distance of 3 meters, using peak detection mode and broadband antennas. The preliminary measurements produced a list of the highest emissions. The E.U.T was then transferred to the open site, and placed on a remote-controlled turntable. The E.U.T was placed on a non-metallic table, 0.8 meters above the ground. The frequency range 30.0MHz -1.0GHz was scanned and the list of the highest emissions was verified and updated accordingly. The readings were maximized by adjusting the antenna height between 1-4 meters, the turntable azimuth between 0-360°, and the antenna polarization. The emissions were measured at a distance of 3 meters.

For measurements between 1.0GHz-25.0GHz:

The E.U.T was tested inside the shielded room at a distance of 3 meters and the E.U.T was placed on a non-metallic table, 1.5 meters above the ground. The frequency range 1.0GHz -25.0GHz was scanned. The readings were maximized by the turntable azimuth between 0-360°, and the antenna polarization. The emissions were measured at a distance of 3 meters.

The E.U.T. was operated at the low, mid and high channels. (2402, 2441, 2480 MHz).

The levels of the emissions within the frequency ranges of the restricted bands (Section 15.205 of FCC Part 15) were compared to the limits of the table in Section 15.209 (a), General Requirements.



13.3 Test Limit

Radiated emissions which fall in the restricted bands, as defined in §15.205(a), must also comply with the radiated emission limits specified in §15.209(a) (see §15.205(c))

Frequency (MHz)	Field strength (microvolts/meter)	Measurement distance (meters)	Field strength* (dBµV/m)	Field strength* (dBµV/m)@3m
0.009-0.490	2400/F(kHz)	300	48.5-13.8	128.5-73.8
0.490-1.705	24000/F(kHz)	30	33.8-23.0	73.8-63.0
1.705-30.0	30	30	29.5	69.5
30-88	100	3	40.0	40.0
88-216	150	3	43.5	43.5
216-960	200	3	46.0	46.0
Above 960	500	3	54.0	54.0

*The emission limits shown in the above table are based on measurements employing a CISPR quasi-peak detector except for the frequency bands 9-90 kHz, 110-490 kHz and above 1000 MHz. Radiated emission limits in these three bands are based on measurements employing an average detector. For average radiated emission measurements above 1000 MHz, there is also a limit corresponding to 20 dB above the indicated values in the table is specified when measuring with peak detector function.

13.4 Test Results

JUDGEMENT: Passed

The EUT met the requirements of the F.C.C. Part 15, Subpart C 209 specification.

For additional information see *Figure 76* and *Figure 77*.



Radiated Emission

E.U.T Description Bluetooth Communication System for Motorcycles
Type scala rider FREECOM2
Serial Number: Not designated

Specification: FCC, Part 15, Subpart C

Antenna Polarization: Horizontal/Vertical Frequency range: 9 kHz to 25.0 GHz
Test Distance: 3 meters Detector: Peak

Operation Frequency (MHz)	Freq. (MHz)	Polarity (H/V)	Peak Reading (dB μ V/m)			Peak Limit (dB μ V/m)	Peak Margin (dB)
			X axis	Y axis	Z axis		
2402.0	2390.0	H	51.9	51.9	51.9	74.0	-22.1
2402.0	2390.0	V	52.2	52.2	52.2	74.0	-21.8
2402.0	4804.0	H	62.2	66.1	61.9	74.0	-7.9
2402.0	4804.0	V	66.4	64.9	59.6	74.0	-7.6
2402.0	7206.0	H	69.2	68.8	64.5	74.0	-4.8
2402.0	7206.0	V	60.5	66.6	61.1	74.0	-7.4
2402.0	9608.0	H	67.7	65.9	63.8	74.0	-6.4
2402.0	9608.0	V	61.3	68.1	57.9	74.0	-5.9
2402.0	12010.0	H	42.9	41.4	45.2	74.0	-28.8
2402.0	12010.0	V	42.9	41.4	33.3	74.0	-31.1
2441.0	4882.0	H	62.6	66.2	59.3	74.0	-7.8
2441.0	4882.0	V	65.9	62.0	62.8	74.0	-8.1
2441.0	7323.0	H	64.9	64.5	59.2	74.0	-9.1
2441.0	7323.0	V	57.9	64.0	60.8	74.0	-10.0
2480.0	4960.3	H	62.3	66.0	59.0	74.0	-8.0
2480.0	4960.0	V	65.4	58.7	62.8	74.0	-8.6
2480.0	7439.2	H	63.8	61.7	57.9	74.0	-10.2
2480.0	7439.4	V	59.2	60.3	59.6	74.0	-13.7
2480.0	9920.0	H	67.8	66.0	60.6	74.0	-6.2
2480.0	9920.0	V	62.3	67.4	66.4	74.0	-6.6
2480.0	2483.5	H	49.7	49.7	49.7	74.0	-24.3
2480.0	2483.5	V	50.1	50.1	50.1	74.0	-23.9

Figure 76. Radiated Emission, Detector: Peak

Margin refers to the test results obtained minus specified requirement; thus a positive number indicates failure, and a negative result indicates that the product passes the test.

“Peak Reading” includes correction factor.

“Correction Factor” = Antenna Factor + Cable Loss- Low Noise Amplifier Gain



Radiated Emission

E.U.T Description Bluetooth Communication System for Motorcycles
Type scala rider FREECOM2
Serial Number: Not designated

Specification: FCC, Part 15, Subpart C

Antenna Polarization: Horizontal/Vertical
Test Distance: 3 meters

Frequency range: 9 kHz to 25.0 GHz
Detector: Average

Operation Frequency (MHz)	Freq. (MHz)	Polarity (H/V)	Average Reading (dB μ V/m)			Average Limit (dB μ V/m)	Average Margin (dB)
			X axis	Y axis	Z axis		
2402.0	2390.0	H	39.8	39.8	39.8	54.0	-14.2
2402.0	2390.0	V	39.6	39.6	39.6	54.0	-14.4
2402.0	4804.0	H	50.0	52.1	47.8	54.0	-1.9
2402.0	4804.0	V	51.27	50.9	47.8	54.0	-2.73
2402.0	7206.0	H	52.3	51.3	49.7	54.0	-1.7
2402.0	7206.0	V	47.1	51.1	48.9	54.0	-2.9
2402.0	9608.0	H	51.2	49.9	47.6	54.0	-2.8
2402.0	9608.0	V	45.9	51.9	45.2	54.0	-2.1
2402.0	12010.0	H	30.0	27.7	40.9	54.0	-13.1
2402.0	12010.0	V	30.0	27.7	27.0	54.0	-24.0
2441.0	4882.0	H	49.9	52.7	46.6	54.0	-1.3
2441.0	4882.0	V	53.0	48.9	50.1	54.0	-1.0
2441.0	7323.0	H	48.9	44.4	43.7	54.0	-5.1
2441.0	7323.0	V	43.3	48.0	44.7	54.0	-6.0
2480.0	4960.3	H	49.7	52.2	45.6	54.0	-1.8
2480.0	4960.0	V	52.3	45.3	49.7	54.0	-1.7
2480.0	7440.0	H	48.9	47.0	43.7	54.0	-5.1
2480.0	7440.0	V	45.0	45.7	45.8	54.0	-8.2
2480.0	9920.0	H	52.1	50.1	44.8	54.0	-1.9
2480.0	9920.0	V	46.2	51.8	50.3	54.0	-2.2
2480.0	2483.5	H	38.7	38.7	38.7	54.0	-15.3
2480.0	2483.5	V	38.7	38.7	38.7	54.0	-15.3

Figure 77. Radiated Emission, Detector: Average

Notes:

Margin refers to the test results obtained minus specified requirement; thus a positive number indicates failure, and a negative result indicates that the product passes the test.

“Avg Reading” includes Avg factor.



13.5 **Field Strength Calculation**

The field strength is calculated directly by the EMI Receiver software, and a "Correction Factors" data disk, using the following equation:

$$[\text{dB}\mu\text{v/m}] \text{ FS} = \text{RA} + \text{AF} + \text{CF}$$

- FS: Field Strength [dB μ v/m]
- RA: Receiver Amplitude [dB μ v]
- AF: Receiving Antenna Correction Factor [dB/m]
- CF: Cable Attenuation Factor [dB]

Example: FS = 30.7 dB μ V (RA) + 14.0 dB (AF) + 0.9 dB (CF) = 45.6 dB μ V

No external pre-amplifiers are used.



13.6 Test Equipment Used, Emissions in Restricted Frequency Bands

Instrument	Manufacturer	Model	Serial Number	Last Calibration Date	Next Calibration Due
EMI Receiver	R&S	ESCI7	100724	February 29, 2016	March 1, 2017
Spectrum Analyzer	HP	8592L	3826A01204	March 13, 2016	March 13, 2017
EMI Receiver	HP	8542E	3906A00276	March 3, 2016	March 3, 2017
RF Filter section	HP	85420E	3705A00248	March 3, 2016	March 3, 2017
Horn Antenna	ETS	3115	29845	May 19, 2015	May 19, 2018
Log Periodic Antenna	EMCO	3146	9505-4081	April 23, 2016	April 23, 2017
Biconical Antenna	EMCO	3110B	9912-3337	March 24, 2016	March 24, 2018
Active Loop Antenna	EMCO	6502	9506-2950	November 4, 2015	November 30, 2016
Low Noise Amplifier	DBS MICROWAVE	LNA-DBS-0411N313	013	August 8, 2016	August 8, 2017
Low Noise Amplifier	Sophia Wireless	LNA 28-B	232	August 8, 2016	August 8, 2017
Semi Anechoic Civil Chamber	ETS	S81	SL 11643	N/A	N/A
Antenna Mast	ETS	2070-2	9608-1497	N/A	N/A
Turntable	ETS	2087	-	N/A	N/A
Mast & Table Controller	ETS/EMCO	2090	9608-1456	N/A	N/A

Figure 78 Test Equipment Used

14. Avg. Factor Calculation

1. Pulse period = 1msec (worst scenario)
2. Pulse duration = 1 msec (worst scenario)
3. Burst duration of Standard modulation =.396msec
4. Burst duration of EDR modulation =2.92msec

$$5. \text{ Average Factor} = 20 \log \left[\frac{\text{Pulse duration}}{\text{Pulse period}} \times \frac{\text{burst duration}}{100\text{msec}} \times \text{Num of burst within 100msec} \right]$$

$$\text{Average Factor} = 20 \log \left[1 * \frac{.369}{100} * 2 \right] = -42.6\text{dB} \text{ for Standard modulation}$$

$$\text{Average Factor} = 20 * \log \left[\frac{2.92}{100} * 1 \right] = -30.69\text{dB} \text{ for EDR modulation}$$

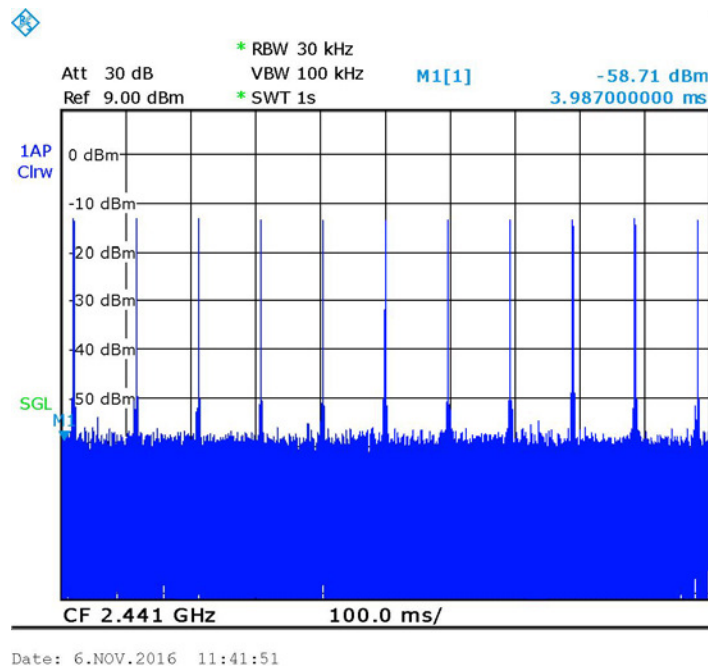

Figure 79 — Number of Bursts in 100m sec=2 standard modulation

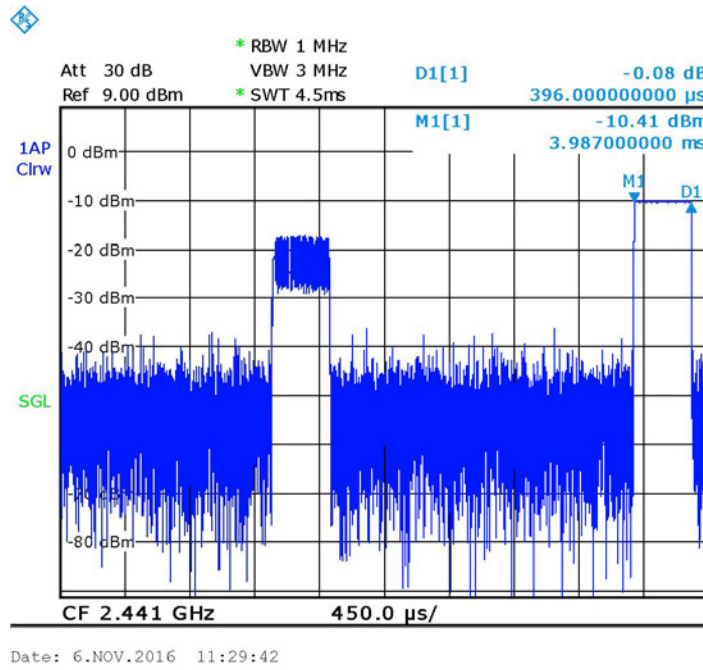

Figure 80 — Burst Duration =.396mS standard modulation

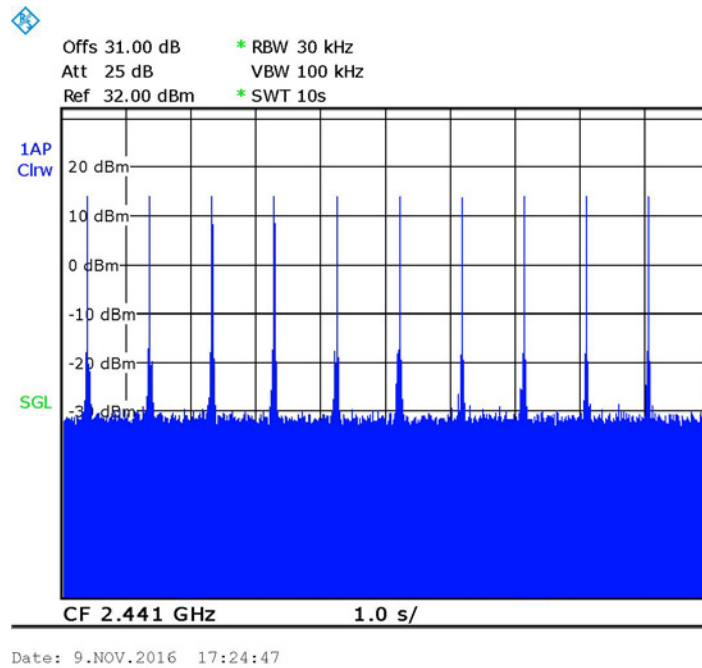

Figure 81 — Number of Bursts in 10 sec=10 EDR modulation

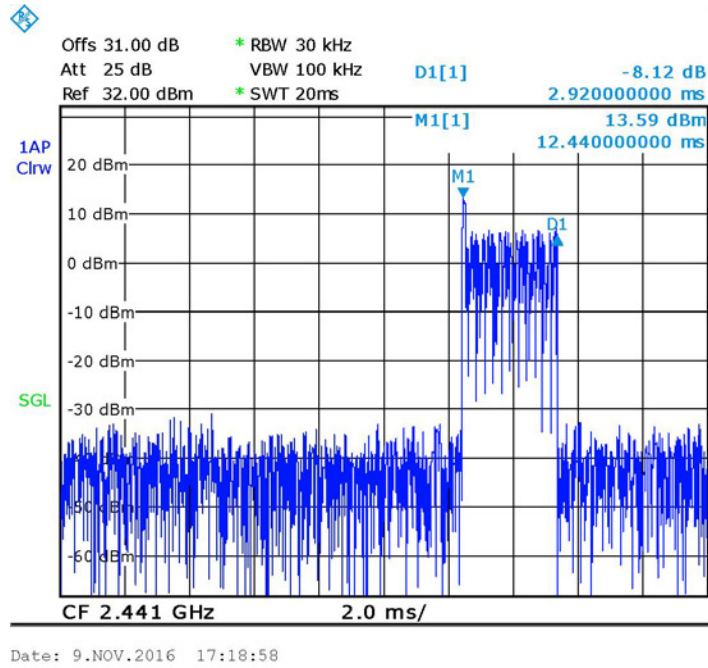

Figure 82 — Burst Duration =2.92ms EDR modulation

14.1 Test Equipment Used, Average Factor

Instrument	Manufacturer	Model	Serial Number	Last Calibration Date	Next Calibration Due
Spectrum Analyzer	Rodhe & Schwarz	FSL6	100194	February 29, 2016	March 1, 2017
30dB Attenuator	Bird	8304-N30DB	533	June 1, 2016	June 1, 2017

Figure 83 Test Equipment Used



15. Antenna Gain/Information

The antenna gain is -2.0 dBi, integral.



16. R.F Exposure/Safety

The typical placement of the E.U.T. is on a motorcycle helmet. The typical distance between the E.U.T. and the user is 4cm. See photo on following page.

SAR Testing Exclusion Based on Section 4.3.1 and Appendix A of KDB447498 D01 V05 and RSS 102, Issue 5, Section 2.5.2 Requirements

For FCC

Section 4.3.1 and Appendix A of KDB447498 D01 V05 was used as the guidance as follows:

Peak power output (standard) = 19.99 dBm=99.8mW.

Taking into account the -42.6dB AVG factor (page 70)

peak power = 19.99- 42.6= -22.61dBm =0.0055mW

$[(\text{max. power of channel, including tune-up tolerance, mW})/(\text{min. test separation distance, mm})] * [\sqrt{f(\text{GHz})}]$

=0.005/40 * 1.55=0.0002 this value is less than 3.0 for 1-g SAR and ≤ 7.5 for 10-g extremity SAR.

The SAR measurement is not necessary

For IC

(a) For IC per Table 1 of RSS 102 Issue 5, SAR exemption based on IC limit of 173.0mW at a separation distance of 40mm= 4.0cm at 2450 MHz.

EUT power transmission is 19.99 dBm= 99.8mW.

Taking into account the -42.6dB AVG factor (page 70)

peak power = 19.99- 42.6 =-22.61dBm =0.0055mW

This is below the 173.0mW SAR exemption limits.

See next page for photos.

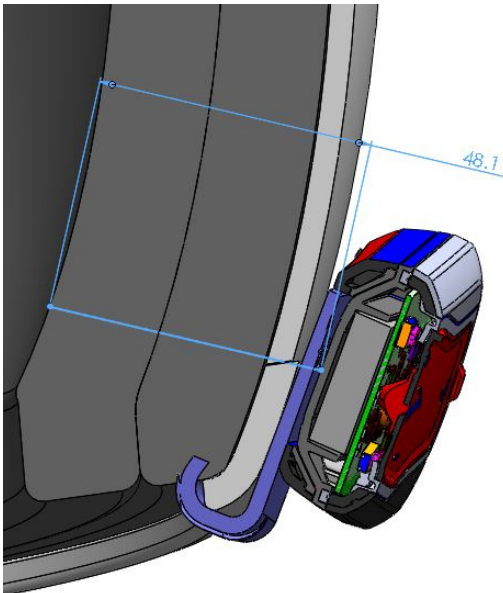
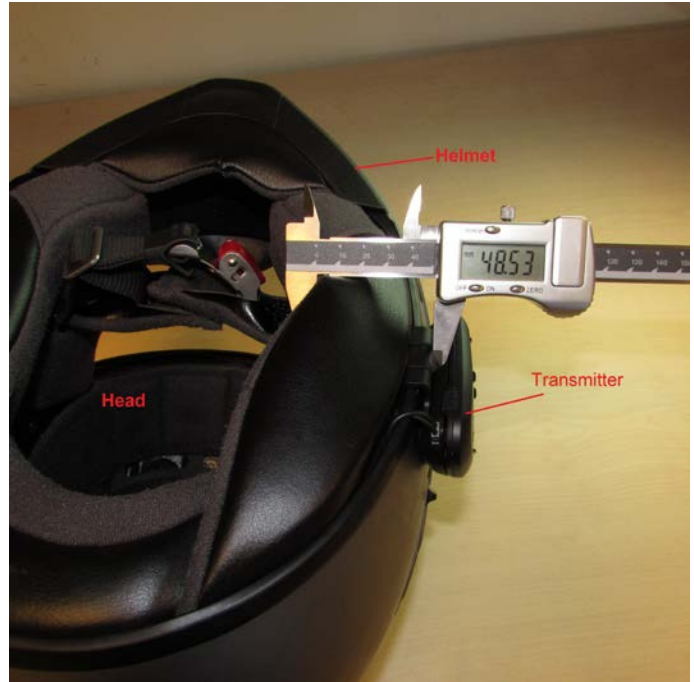



APPENDIX A - CORRECTION FACTORS

16.1

**Correction factors for
CABLE from EMI receiver
to test antenna
at 3 meter range.**

Frequency (MHz)	Cable Loss (dB)
0.010	0.4
0.015	0.2
0.020	0.2
0.030	0.3
0.050	0.3
0.075	0.3
0.100	0.2
0.150	0.2
0.200	0.3
0.500	0.4
1.00	0.4
1.50	0.5
2.00	0.5
5.00	0.6
10.00	0.8
15.00	0.9
20.00	0.8

Frequency (MHz)	Cable Loss (dB)
50.00	1.2
100.00	0.7
150.00	2.1
200.00	2.3
300.00	2.9
500.00	3.8
750.00	4.8
1000.00	5.4
1500.00	6.7
2000.00	9.0
2500.00	9.4
3000.00	9.9
3500.00	10.2
4000.00	11.2
4500.00	12.1
5000.00	13.1
5500.00	13.5
6000.00	14.5

NOTES:

- 1. The cable type is SPUMA400 RF-11N(X2) and 39m long*
- 2. The cable is manufactured by Huber + Suhner*



16.2 Correction factor for RF CABLE for Semi Anechoic Chamber

FREQ (MHz)	LOSS (dB)
1000.0	1.5
2000.0	2.1
3000.0	2.7
4000.0	3.1
5000.0	3.5
6000.0	4.1
7000.0	4.6
8000.0	4.9
9000.0	5.7
10000.0	5.7
11000.0	6.1
12000.0	6.1
13000.0	6.2
14000.0	6.7
15000.0	7.4
16000.0	7.5
17000.0	7.9
18000.0	8.1
19000.0	8.8
20000.0	9.1

NOTES:

- 1. The cable is manufactured by Commscope*
- 2. The cable type is 0623 WBC-400, serial # G020132 and 10m long*
- 3. ITL # 1841*



16.3 Correction factors for Low Loss CABLE

Huber Suner #1696

Serial No. 705A009301 EIM

FREQ (MHz)	INPUT (dBm)	OUTPUT (dBm)	LOSS (dB)
1000.0	-10	-10.7	0.7
2000.0	-10	-10.7	0.7
3000.0	-10	-10.6	0.6
4000.0	-10	-10.5	0.5
5000.0	-10	-10.7	0.7
6000.0	-10	-10.8	0.8
7000.0	-10	-10.8	0.8
8000.0	-10	-11.0	1.0
9000.0	-10	-10.5	0.5
10000.0	-10	-10.3	0.3
11000.0	-10	-10.5	0.5
12000.0	-10	-11.3	1.3
13000.0	-10	-11.6	1.6
14000.0	-10	-11.8	1.8
15000.0	-10	-11.0	1.0
16000.0	-10	-10.6	0.6
17000.0	-10	-12.0	2.0
18000.0	-10	-11.6	1.6



16.4 Correction factors for ACTIVE LOOP ANTENNA

**Model 6502
S/N 9506-2950**

f(MHz)	MAF(dBs/m)	AF(dB/m)
0.01	-33.1	18.4
0.02	-37.2	14.3
0.03	-38.2	13.3
0.05	-39.8	11.7
0.1	-40.1	11.4
0.2	-40.3	11.2
0.3	-40.3	11.2
0.5	-40.3	11.2
0.7	-40.3	11.2
1	-40.1	11.4
2	-40	11.5
3	-40	11.5
4	-40.1	11.4
5	-40.2	11.3
6	-40.4	11.1
7	-40.4	11.1
8	-40.4	11.1
9	-40.5	11
10	-40.5	11
20	-41.5	10
30	-43.5	8



16.5 Correction factors for Biconical Antenna
EMCO, Model 3110B,
Serial #9912-3337

Frequency [MHz]	AF [dB/m]
30.0	14.18
35.0	13.95
40.0	12.84
45.0	11.23
50.0	11.10
60.0	10.39
70.0	9.34
80.0	9.02
90.0	9.31
100.0	8.95
120.0	11.53
140.0	12.20
160.0	12.56
180.0	13.49
200.0	15.27



16.6 Correction factors for Log Periodic Antenna
EMCO, Model 3146,
Serial #9505-4081

Frequency [MHz]	AF [dB/m]
200.0	11.47
250.0	12.06
300.0	14.77
400.0	15.77
500.0	18.01
600.0	18.84
700.0	20.93
800.0	21.27
900.0	22.44
1000.0	24.10



16.7 **Correction factors for Horn ANTENNA.**

Model: 3115

Antenna serial number: 29845

3 meter range

f(GHz)	AF(dB/m)	GA(dB)
0.75	25	3
1G	23.5	7
1.5G	26	8
2G	29	7
2.5G	27.5	10
3G	30	10
3.5G	31.5	10
4G	32.5	9.5
4.5G	32.5	10.5
5G	33	10.5
5.5G	35	10.5
6G	36.5	9.5
6.5G	36.5	10
7G	37.5	10
7.5G	37.5	10
8G	37.5	11
8.5G	38	11
9G	37.5	11.5
9.5G	38	11.5
10G	38.5	11.5
10.5G	38.5	12
11G	38.5	12.5
11.5G	38.5	13
12G	38	13.5
12.5G	38.5	13
13G	40	12
13.5G	41	12
14G	40	13
14.5G	39	14
15G	38	15.5
15.5G	37.5	16
16G	37.5	16
16.5G	39	15
17G	40	15
17.5G	42	13.5
18G	42.5	13