



Saflok RT/RT Plus

Installation instructions

PK3720-T - 2022 - 06

EN

dormakaba 

Table of Contents

Saflok RT/RT Plus

ASM, ESM, ASM Auto Deadbolt Mortises & Cylindrical Models 2³/₈" and 2³/₄" Backset

Stand Alone (79S), Ambiance RX Ready (79R), Ambiance RX (79Z,Y,Q), and Escape Return (79N) Models

03	1. Introduction and Disclaimers
04	2. Checklist and Exploded Views
04	2.1. Parts and Tools List
06	2.2. ASM/ESM
07	2.3. Autodeadbolt ASM Inside Trim Assembly
08	3. Installation of Standard ASM or ESM Models
08	3.1. Check the Mortise Handing
09	3.2. Install the Strike
10	3.3. Install the Mortise
11	3.4. Install the Outside Housing & Inside Trim Assembly without key override
12	3.5. Reversing the Outside Lever
13	4. Installing the Mechanical Override Model
	Appendices
	A. Mortise Models
21	A.1. Reversing the Mortise Handing
21	A.1.1. Reversible ASM
24	A.1.2. Reversible ESM
26	A.2. Additional Steps for Autodeadbolt ASM
27	A.3. Additional Steps for ASM Office
27	A.4. Additional Steps for ASM/ESM Storeroom
28	B. Cylindrical Models
28	B.1. Installing Cylindrical Models
28	B.1. Install the Strike
28	B.2. Install the Latch
29	B.3. Install the Cylindrical Unit
30	B.4. Inside Trim Assembly
31	B.5. Install Outside Housing & Trim Assembly
33	C. Escape Return Model (79N)
33	C.1. ASM/ESM & ADB Inside trim assembly for 79N
33	C.2. Installation of extension spring on inside trim assembly
34	Installation Guide Lexicon

Note: This installation Guide is for Saflok RT and RT Plus lock. Images of the lock may vary depending on installed options.

1 Introduction and Disclaimers

IMPORTANT

Please read and follow all directions carefully.

Target Audience

These instructions are designed for use by maintenance professionals or lock installers who are familiar with common safety practices and competent to perform the steps described. Kaba is not responsible for damage or malfunction due to incorrect installation however arising.

Definition of Terms

In these instructions, the term ASM refers to American Standard Mortise, and ESM refers to European Slim Mortise, and ADB refers to Autodeadbolt Mortise.

Technical Assistance

For technical assistance, call: 1 800 999 6213

IMPORTANT

Carefully inspect windows, doorframe, door, etc. to ensure that the recommended procedures will not cause damage. dormakaba standard warranty does not cover damages caused by installation.

For all mortise models the gap between the mortise front plate and the strike must not exceed $\frac{1}{4}$ "

IMPORTANT

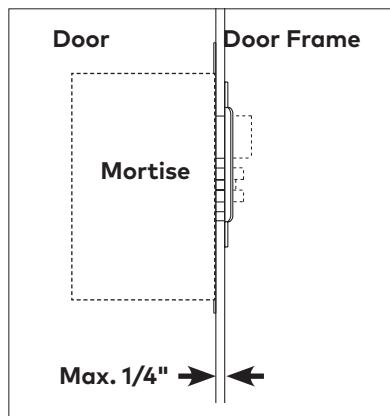

⚠ CAUTION

Wear safety glasses when making the holes.

2 Checklist and Exploded Views

2.1 Parts and Tools List

Each lockset includes:

(A) Outside lever handle

(or)

Parts for Mechanical override model only:

(A1) Outside lever handle

(B1) Outside housing

(C1) Cylinder plug

(D1) Cylinder

(E1) Cylinder cap

(E2) Instruction sheet "How to attach lever on lock"

(B) Outside housing

(C) Battery holder with 3 AA Alkaline batteries

(D) Mortise (ASM only shipped assembled with face plate (P) and 2 x 8-32 x 1/4" screws (D12))

(or)

Parts for cylindrical models (see illustrations in appendix B):

- cylindrical latch (see Section B.2)

- cylindrical unit assembled with one pair of screws & 3 spacers

- four (4) other pairs of screws & three (3) spacers in hardware bag

- additional extension spring

- storeroom function locking screw and nut

(E) Inside trim assembly, details depend on lock model (see 2.2, 2.3, 2.4)

(N) Outdoor gasket included in cylindrical latch locks only.

Order separately for locks with mortise. ESSENTIAL FOR OUTDOOR INSTALLATIONS

P/N: 033-512017-1

2 Checklist continued

Parts inside hardware bag:

- (C1) 1x Cylinder plug (for K model only)
- (E1) 1x Cylinder cap (for K model only)
- (F) 1x Thumbturn (hex) spindle
- (G) 1x Square spindle
- (H) 1x Torx-head screw
- (I) 3x Mounting screws (10-24, 1/8 Hex Head) or (12-24, 1/8" Hex Head for recent models only)
- (J) 2x Machined screws (12-24X 1/2" Philips) & 2 wood screws (#12 X 1" Philips)
- (K) 1x Strike kit (screws, strike and ASM or Cylindrical dustbox)
- (L) 1x Extension spring
- (M) 1x Parts required to control thumbturn motion for (ASM and ESM Storeroom, ASM Office See appendix A3 & A4)
- (S) 3x Spacers
- (Y) 4x Pairs of Flat Head Screws 10-24 (for cylindrical only, see appendix B door thickness table)
- (Z) 3x Spacers (for cylindrical only, see appendix B door thickness table)

Tools Required:

- Safety glasses
- 1/2" (13mm) chisel
- 1/8" (3mm) drill bit
- 1/4" (6.5mm) drill bit (ESM only)
- 1/2" (13mm) drill bit
- 3/4" (22mm) drill bit or hole saw
- 1" (25.4mm) drill bit or hole saw
- Drill
- Awl or center punch
- 2 1/8" (54mm) hole saw (Cylindrical Only)
- Hammer Rubber mallet
- Small flat screwdriver
- Torx screwdriver (T-15) (760 Series)
- Phillips screwdriver (#2)
- Fine steel file
- Mortising machine
- Router
- Mortise face plate router template
- Adjustable square
- Tape measure
- Pencil
- Tape
- Installation Jig (Recommended)
- Lock Template
- Cleaning supplies (drop cloth, vacuum)
- 1/8" Allen Key
- 5/64" Allen Key

IMPORTANT

For doors more than 2 1/2" thick up to 3 3/4", order the appropriate hardware bag to receive the correct length of spindles and mounting screws. Part# 062-512868-XXX; (XXX = choice of finish).

For outdoor installations, order gasket 033-512017-1. Gasket comes standard with cylindrical locks and ultra finish locks.

2 Exploded Views

2.2 ASM/ESM (For Cylindrical, see Appendix B)

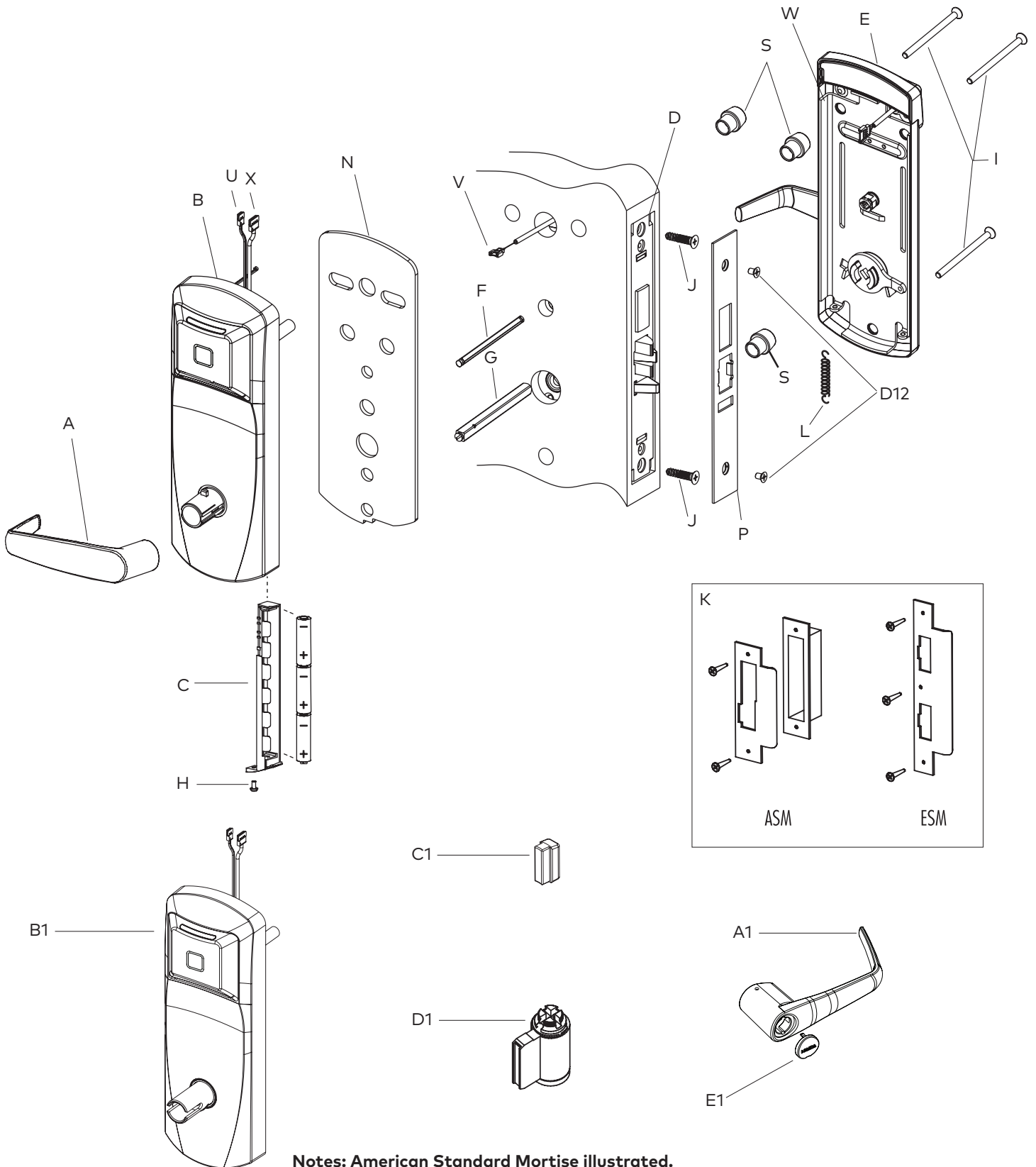

2 Exploded Views

2.3 Autodeadbolt ASM Inside Trim Assembly

NOTE:

The inside trim assembly (E) for autodeadbolt models includes the parts (E3, E4, E5, E17) shown, assembled at the factory.

For ASM Office and ASM/ESM Store-room models, only some of the parts (E) are used. See instructions in Appendix A.

Parts (E3, E4, E5, E17) also available separately (kit #O62-510484-K) to convert the standard lock to Autodeadbolt ASM, ASM Office or ASM/ESM Storeroom functions.

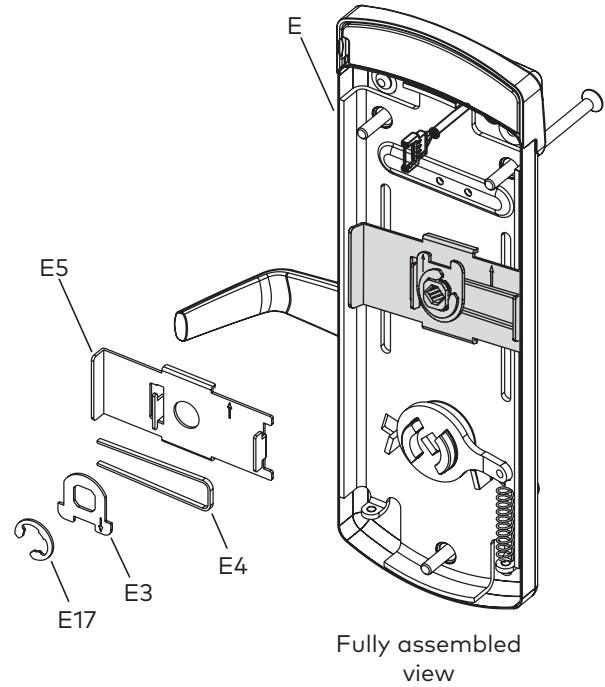

3 Installation of Standard ASM or ESM Models

(for cylindrical see Appendix B)

3.1 Check the Mortise Handing

Compare the mortise with the diagram below. If the mortise is the correct handing for the door, continue with step 3.2.

IMPORTANT

Refer to Appendix A.1 to change the handing of a field-reversible mortise.

ASM

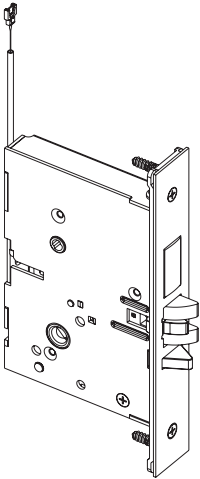

For LH (left hand) and RHR (right hand reverse)

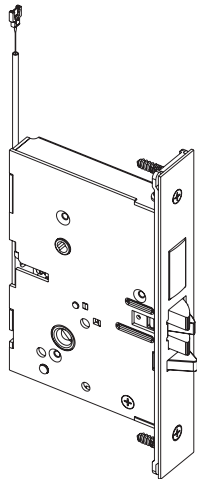

For RH (right hand) and LHR (left hand reverse)

ESM

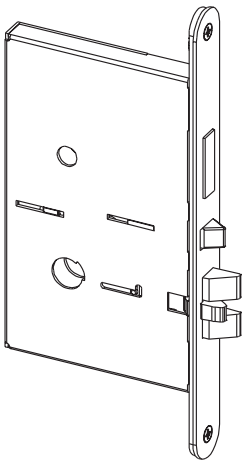

For LH (left hand) and RHR (right hand reverse)

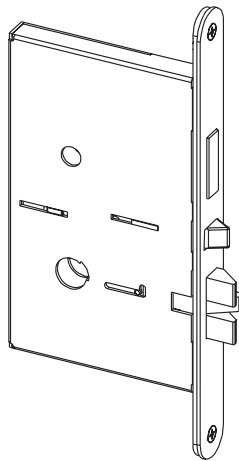

For RH (right hand) and LHR (left hand reverse)

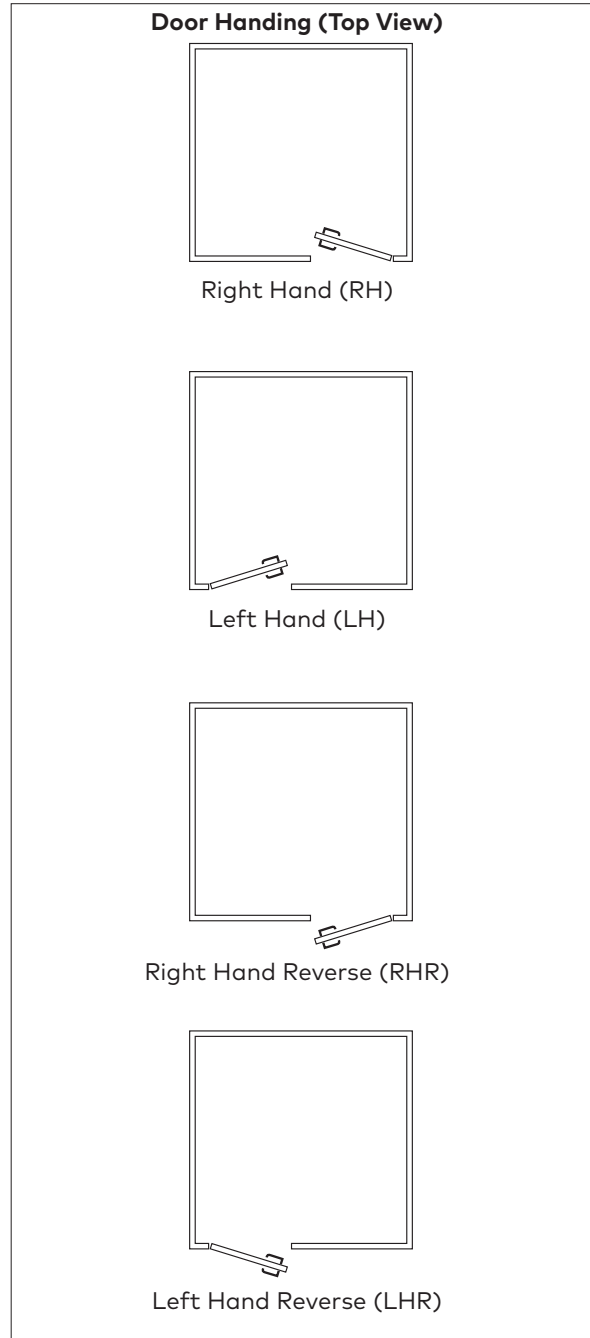

	dormakaba Canada Inc. 7301 Decarie Blvd. Montreal Quebec Canada H4P 2G7
	0432-CPR-00072-06.01 22
	EN 12209: 2003/AC:2005 3M510G4H010
	None
ESM MORTISE	
	dormakaba Canada Inc. 7301 Decarie Blvd. Montreal Quebec Canada H4P 2G7
	0432-CPR-00072-06.01 22
	EN 12209: 2003/AC:2005 3M510G4H010
	None
ASM MORTISE	

3 Installation of Standard ASM or ESM Models

(for cylindrical see Appendix B)

3.2 Install the Strike

1. Align the paper template on the door frame at the desired handle height (↔), and along the vertical center line of the mortise (CL), which is also the center line of the door edge, allowing for any bumpers on the door frame.

IMPORTANT

Respect applicable building codes regarding handle height.

Note that the centerline of an ESM mortise does NOT pass through the screw holes on the strike.

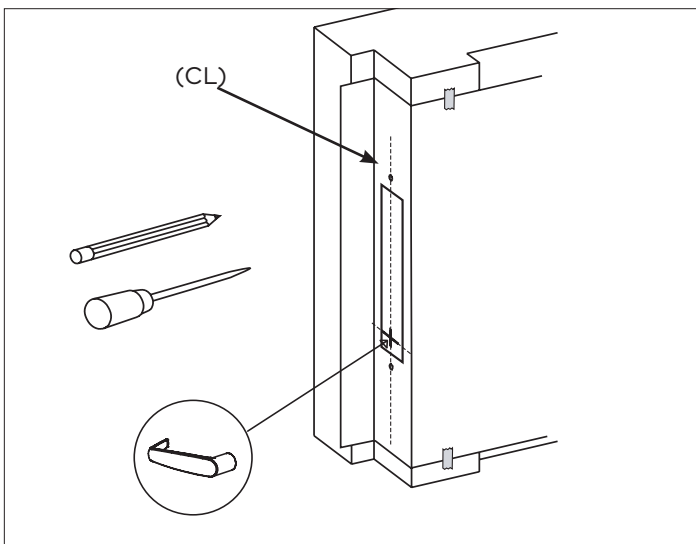

2. Mark the locations of the dust box cutout and mounting screws for the strike.
3. Create the dust box pocket and chisel out the strike contour in the door frame, and drill the pilot holes for the mounting screws (dimensions and depths marked on template).

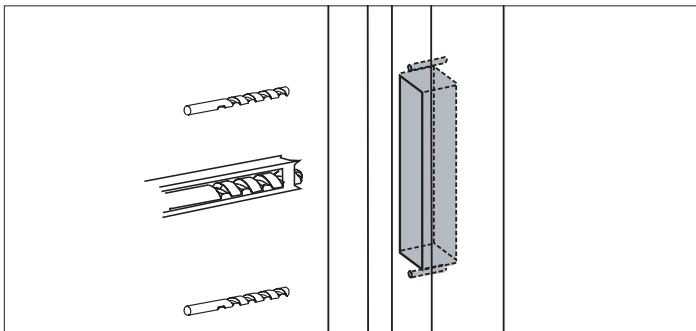

4. Position the strike against the door frame and align it with the mounting screw holes. Trace the outline of the strike.

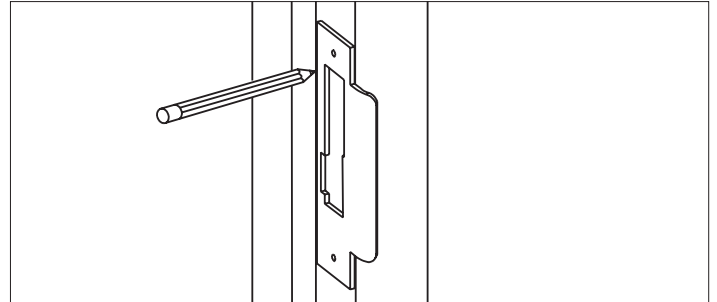

5. Remove material from within the strike outline so that the strike will be flush with the door frame.

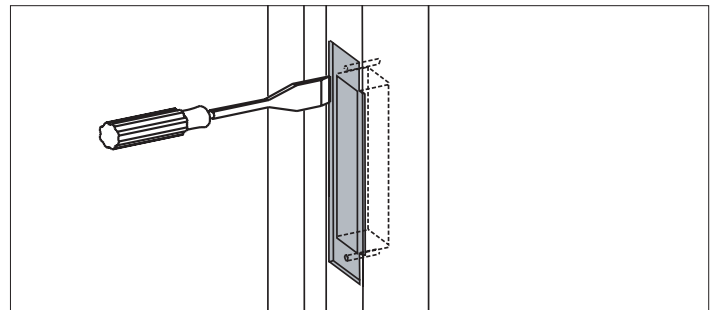

6. For ASM, install the dust box (optional for wood door frames, required for metal door frames), and check the strike handing on the template. For ASM and ESM install the strike using the screws provided. Use wood screws for wood frames and machined screws for steel frames.

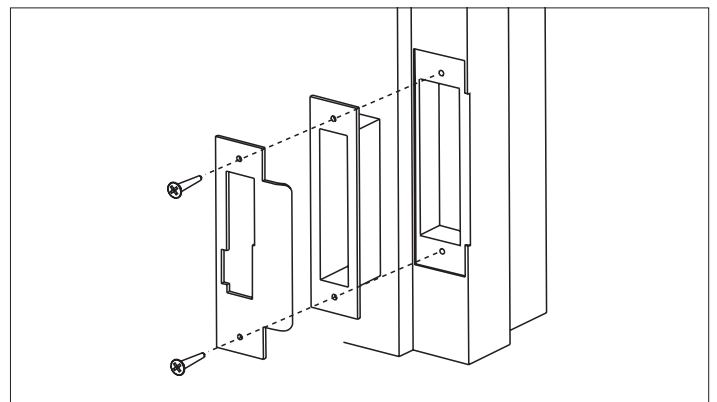

IMPORTANT

When strike is installed on wood frames under one inch thick, wood screws supplied are not adequate. use screws of efficient length to engage the structural stud behind the frame. Use only the strike and dust box supplied. Use of non-approved parts may void the warranty.

3 Installation of Standard ASM or ESM Models

(for cylindrical see Appendix B)

3.3 Install the Mortise (for cylindrical, see Appendix B)

IMPORTANT

If using the installation jig to prepare the door, refer to the instructions provided with the jig, then proceed with step 4 below.

1. Mark the handle () height on the edge of the door, as determined directly from the strike.

For ASM, the axis of rotation of the handle is level with the bottom lip of the strike.

For ESM, the axis of rotation of the handle is 1/4" above the bottom lip of the strike.

2. Align the template along the vertical center line of the mortise (CL) at the desired handle height, and tape it to the door. Mark all holes and cutouts for the mortise in the edge of the door and remove the template.

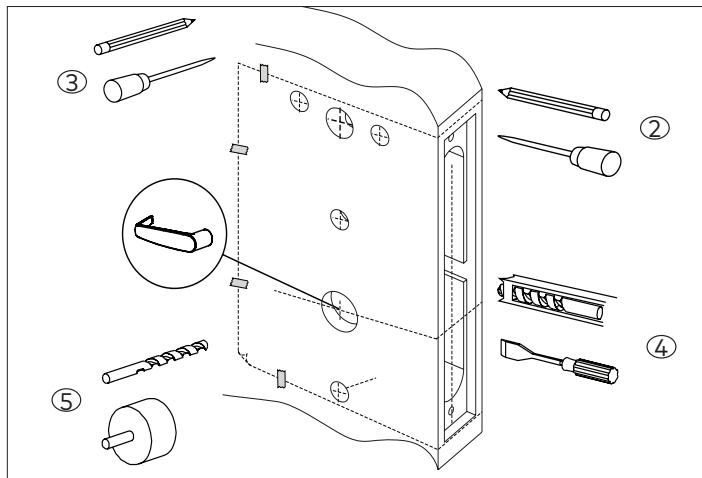
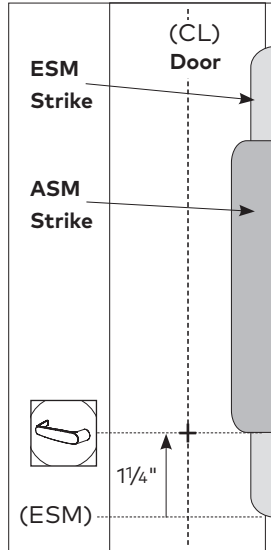

3. Locate the two sets of vertical fold lines on the template allowing you to adjust the positioning of the template depending on the bevel of the door.

If the door has no bevel, fold the template along the solid lines. Align the fold with the edge of the door and mark the holes for the lock. Repeat on the other side of the door.

If the door has a 3° bevel, fold and align the dashed line marked "H" on the template with the higher-beveled edge of the door and mark the lock holes on that side of the door. Repeat on the side with the lower-beveled edge using the dashed line marked "L". Remove the template.

4. Prepare the cut-outs for the mortise in the edge of the door using a mortising machine, router and chisel (for dimensions, refer to template).

Ensure clearance is provided for moving latch parts as indicated on the template.

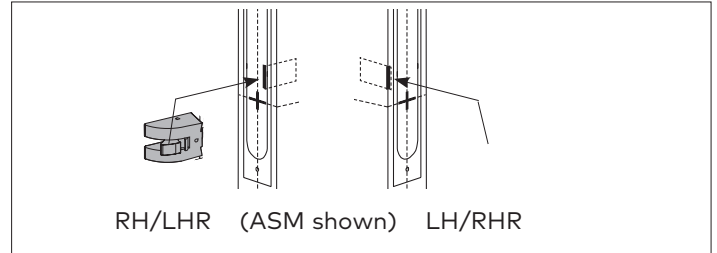

5. Drill the holes in the sides of the door (for dimensions, refer to template).

Drill from both sides of the door to prevent unsightly damage.

6. For ASM only, check the bevel of the mortise. If adjustment is required, loosen bevel screws (R) and adjust mortise front plate angle to match the bevel of the door. Retighten screws.

For models 79R, 79Z, 79Y, 79Q slide the ajar switch cable of the mortise (V) through the hole at the top of the mortise pocket. The cable must go through the outside of the door for connection in the next step.

Install the mortise with 2 screws (J). Use wood screws for wood doors and machined screws for steel doors.

Install mortise faceplate (P) with the two 8-32 x 1/4" screws provided (D12).

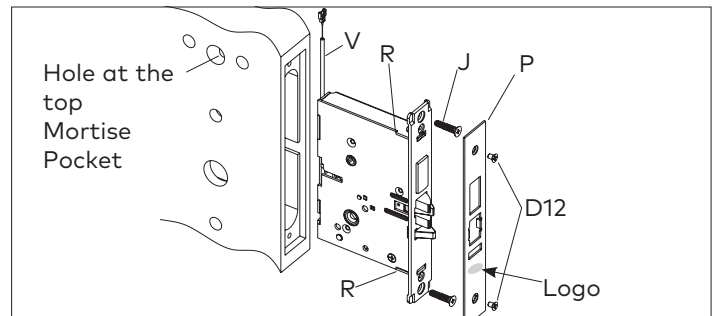

IMPORTANT

The ESM faceplate must be installed so you can read the logo (see arrow in figure above right-side-up for proper operation.)

3 Installation of Standard ASM or ESM Models

(for cylindrical see Appendix B)

3.4 Install the Outside Housing and Inside Trim Assembly Without Key Override (for locks with mechanical key override please refer to section 4).

A- For Mortise

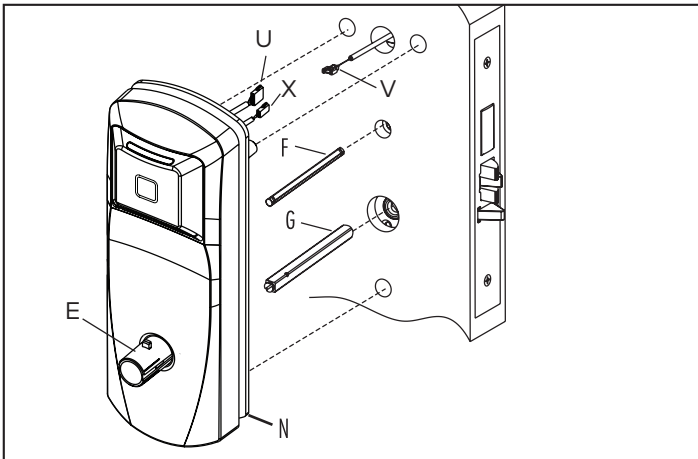

1. Install the gasket (N) (if required) on the outside housing prior to assembly, aligning the notch in the gasket with the battery compartment. See page 4 for gasket information.

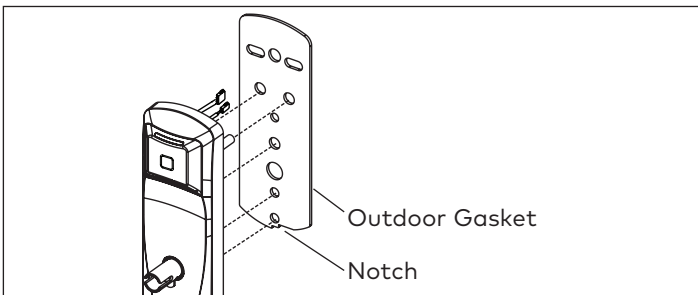

2. Insert the slotted end of the square spindle (G) into the outside lever hub until it locks, at an angle of 45°. (The spindle can be removed by pulling on it, if oriented incorrectly.)

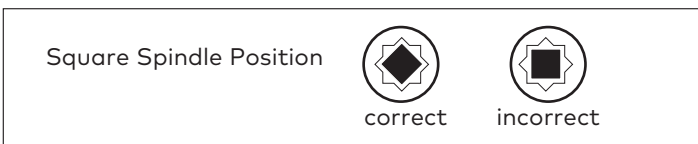

3. Insert the thumbturn spindle (F) in the upper hub of the outside housing. (It will clip in place.)

IMPORTANT

If installing the lock with mortise outdoors, order the proper gasket (See page 4).

For doors more than 2 1/2" thick, order the appropriate hardware bag to receive the correct length of spindles and mounting screws. (See page 4)

4. Place the outside housing on the door so that the spindles engage the hubs on the mortise.

For models 79N see appendix C

For models 79R, 79Z, 79Y, 79Q slide the 2 spindles (F & G) onto the hub of the mortise but leave a gap between the door and the back of the lock. Connect the ajar cable from the housing (U) to the ajar switch cable of the mortise (V). Push the lock to the face of the door ensuring that the cable connection (U) to (V) remains in the door hole, and that the cable for the outside housing antenna (X) protrudes through the hole to the inside of the door.

CAUTION

Ensure no cables are pinched on assembly.

5. On the inside trim assembly turn the lever to the correct horizontal rest position for the handing of the door. Install the tension spring (L) between the handle (E6) and the post (E7).

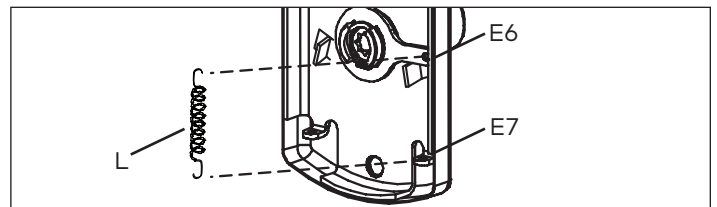

6. Place the grommets (E14) as shown on the image of the inside trim (E). Use screws (E15) and the flat washers (E16) and fasten to the RFID module (E13) to the inside trim assembly (E).

IMPORTANT

Apply only for models 79Z, 79Y, 79Q. Normally assembled at the factory

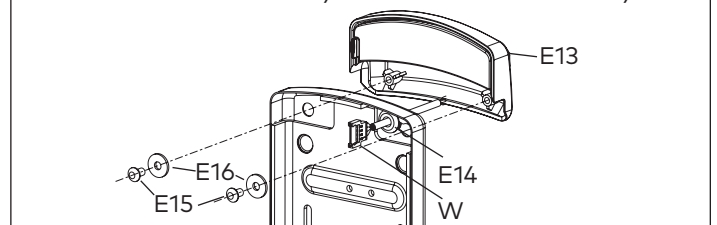

IMPORTANT

For Autodeadbolt ASM, ASM Office and ASM/ESM Store-room models, refer to Appendix A.2, A.3, A.4 at this point.

7. Put the thumbturn (T) in a vertical position. Place 3 spacers (S) on the door (for recent models only) and place the inside trim assembly on the door so that the upper and lower spindles (F) and (G) engage the thumbturn and the inside lever.

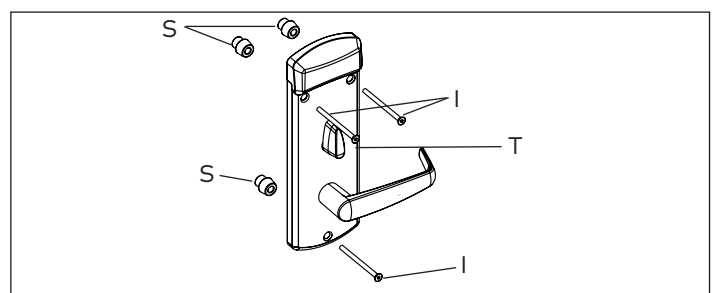

3 Installation of Standard ASM or ESM Models

(for cylindrical see Appendix B)

For models 79Z, 79Y, 79Q connect the outside housing antenna cable (X) to the inside trim antenna cable (W). For the 79R model leave the outside housing antenna cable (X) in the door hole.

⚠ CAUTION

Ensure no cables are pinched on assembly.

Fasten to the outside housing using the three 1/8" hex drive mounting screws (I). Install the screws without tightening. Verify the inside lever and thumbturn operates smoothly. If not move the inside and outside housings slightly. Then tighten the screws.

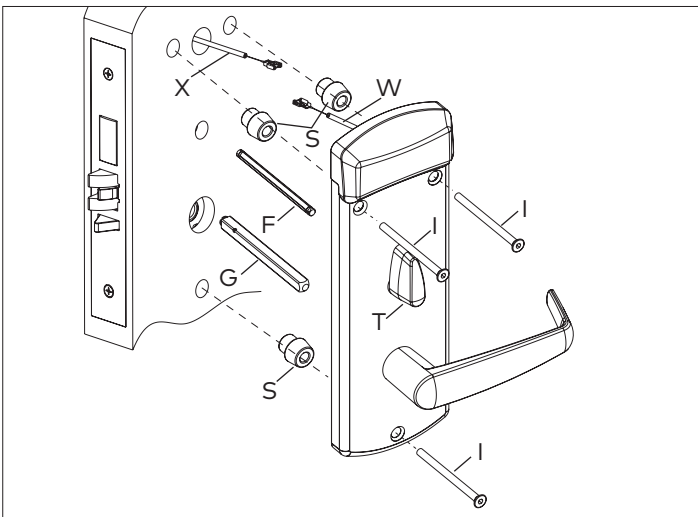

8. Assemble the lever on the outside housing, in the horizontal rest position appropriate to the handing of the door. Simply push the lever onto the tube until it clicks in place. If more force is required, use a rubber mallet. Test the attachment of the handle by pulling smartly on it. (For locks with mechanical override, see section 4 p.12)

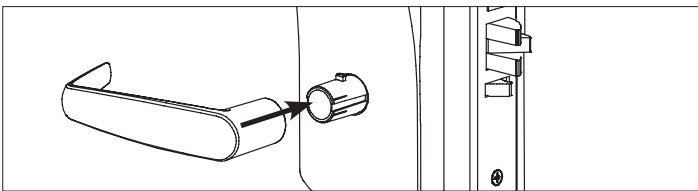

9. Three AA Alkaline batteries should already be installed in the battery holder (C). Insert the battery holder into the outside housing and secure it using the 6-32 x 5/16" (7.9mm) Torx drive screw (H).

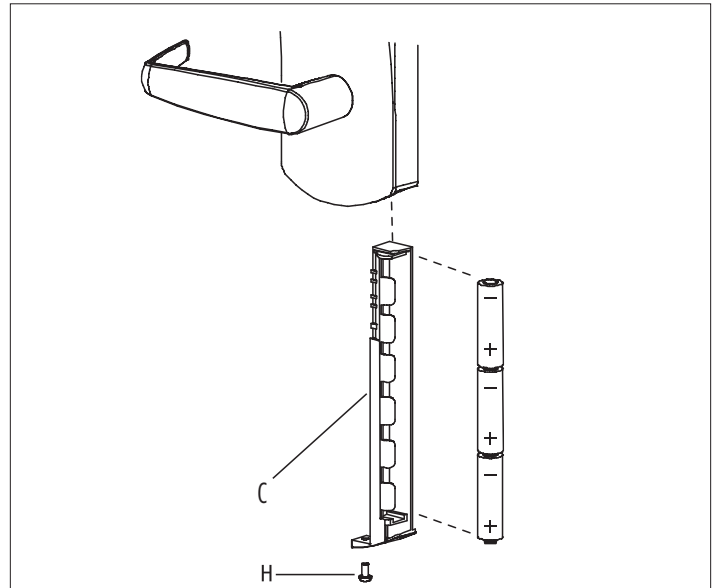

3.5 Reversing the Outside Lever (for series without Mechanical Override)

The lever is field reversible. If the handing is incorrect, insert a small pick or flat screwdriver in the hole in the hub as shown. Gently pry back the spring clip inside the hub, and remove the handle.

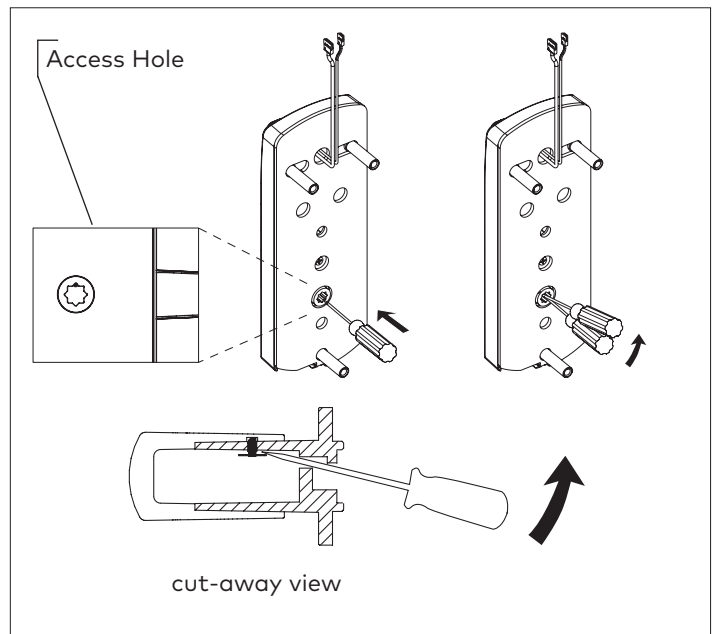

IMPORTANT

If the lock makes a continuous buzzing noise or the red LED lights continuously, reset the electronics by removing the battery holder for ten seconds then reinsert it.

4 Installation of Mechanical Override Model

4.1 Parts and Tools List

Tools Required:

Cylinder (D1, provided with lock) or equivalent

(M1) Small flat screwdriver (less than 1/8")

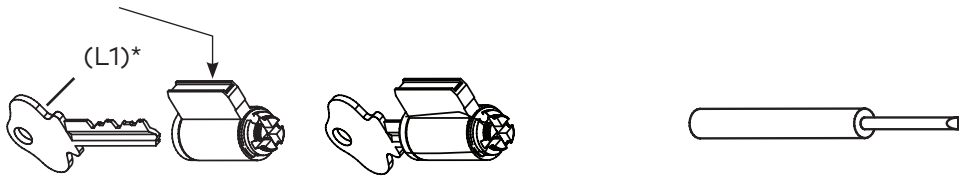

* for recodable cylinder key #1 should be used as L1. See section 11 for more information.

Diagram of lock:

- | | | |
|---------------------------|-----------------------|------------------------------|
| (A1) Outside Lever handle | (F1) Inside drive hub | (K1) Override shaft |
| (B1) Outside housing | (G1) Nylon washer | (O1) Set screw cylinder plug |
| (C1) Cylinder plug | (H1) Spring washer | |
| (D1) Cylinder | (I1) Drive tube | |
| (E1) Cap | (J1) Lever catch | |

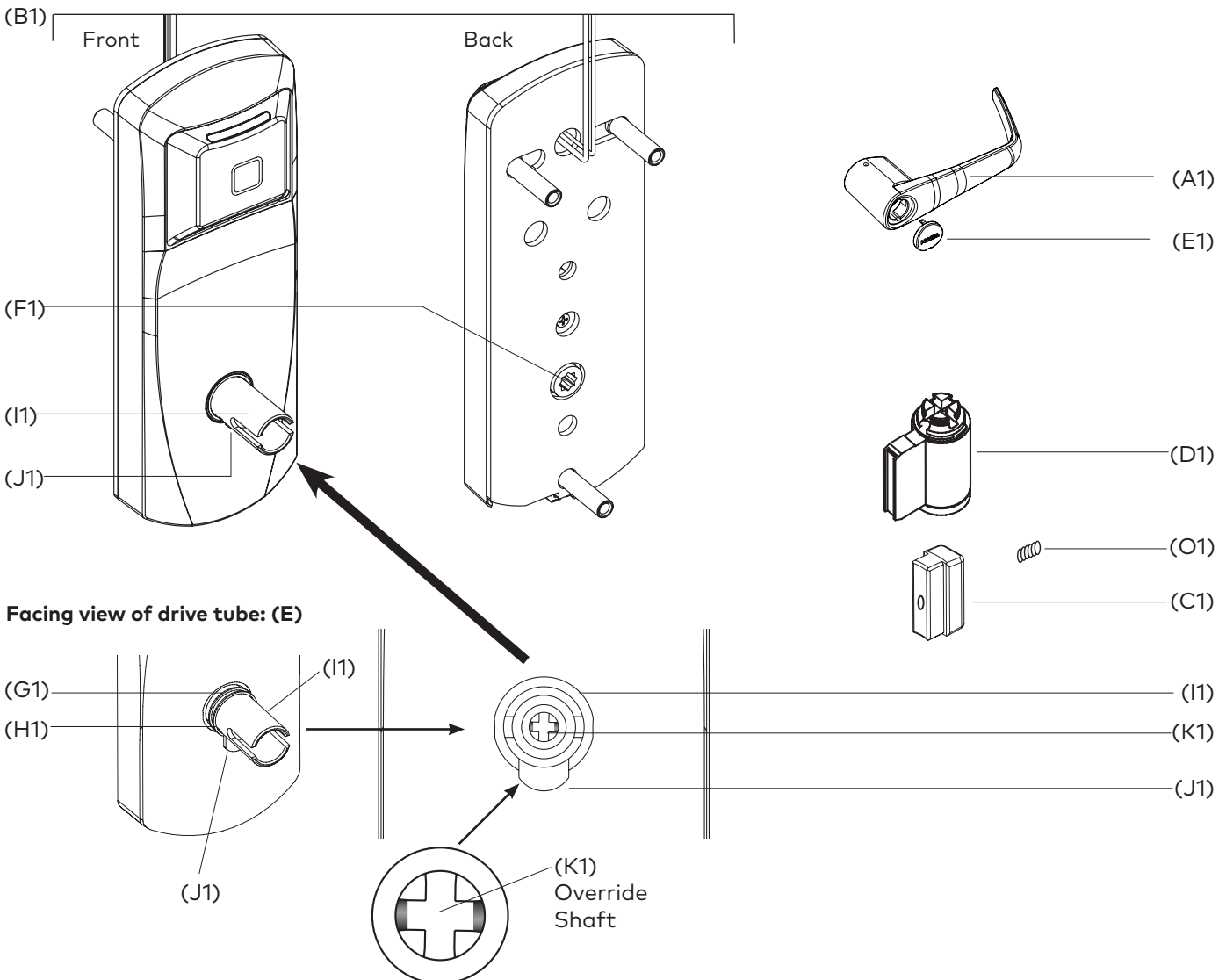

4 Installation of Mechanical Override Model

Upon unpacking, the lock housing with mechanical override should look like the diagram below with:

- (N1) The small indents on the cross of the override shaft in line horizontally
- (G1) The nylon washer and the spring washer on the drive tube (I1)
- (J1) The lever catch in the out position
- (D1) Cylinder

IMPORTANT

Important: Assemble the lever, cylinder and lock components before affixing the entire unit to the door.

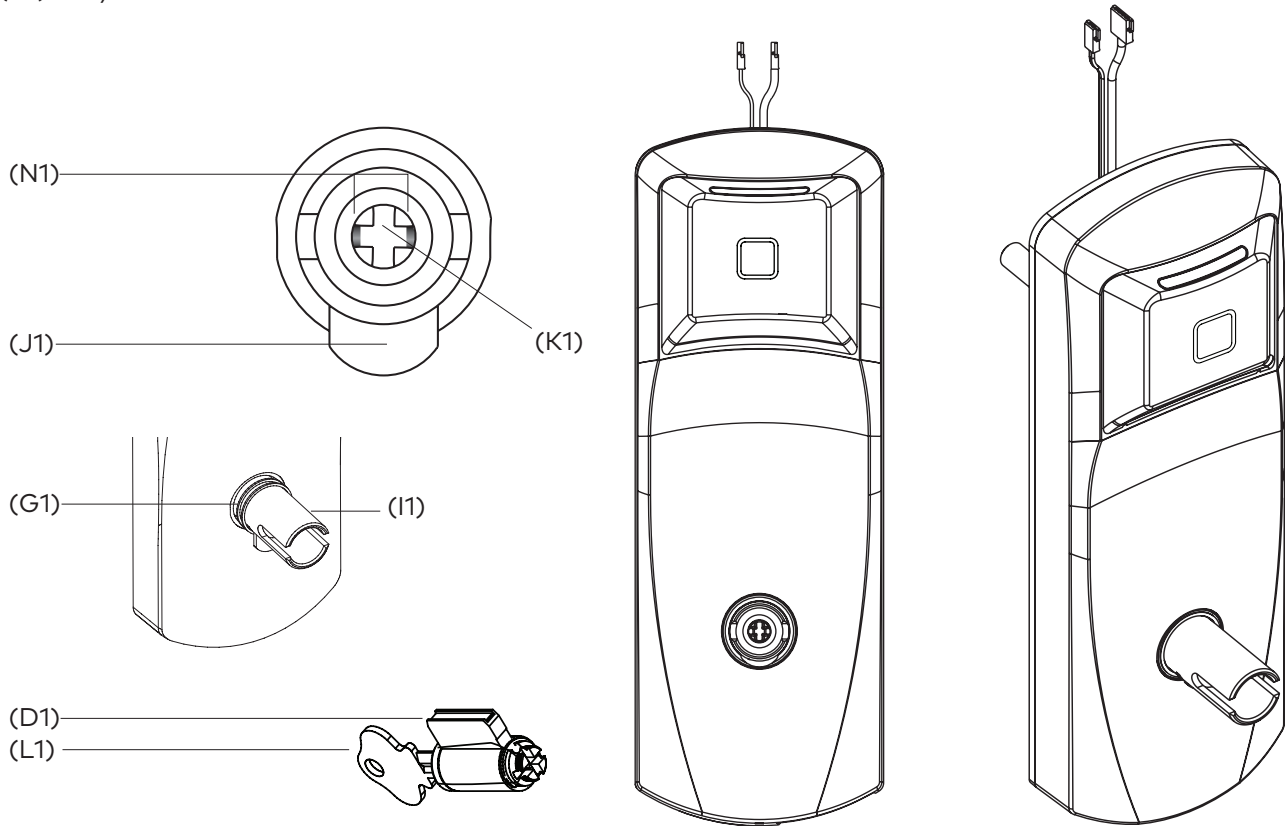

4.2 Preparing the outside housing for the installation of the lever handle

1. Insert the cylinder (D1) to be used as a tool, or an equivalent tool, to rotate the override shaft (K1) and turn it clockwise until it stops so that the two small indents (N1) on the cross are now vertically in line. (Fig.1)
2. Push in the lever catch (J1) firmly. (see Fig. 2) to be flush with drive tube diameter

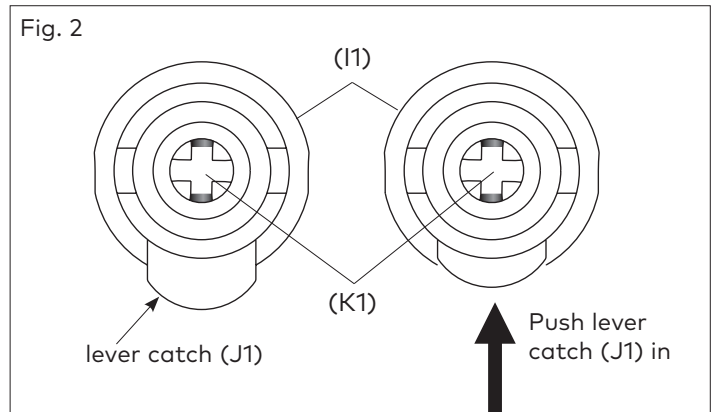
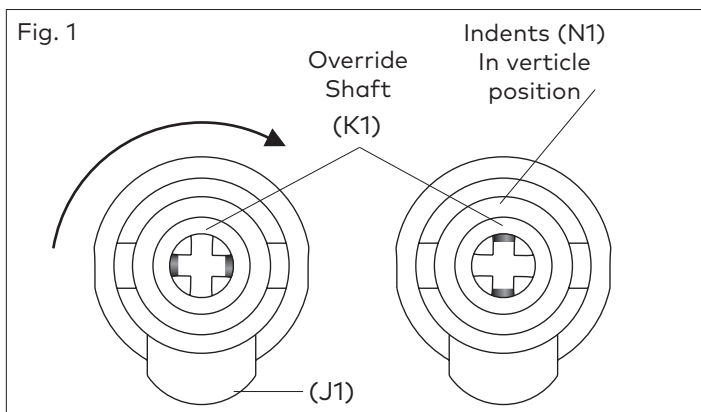

4 Installation of Mechanical Override Model

4.3 Preparing the lever handle and cylinder for installation

3. Insert the cylinder (D1) without key (L1) into the lever handle (A1) (see Fig.3)

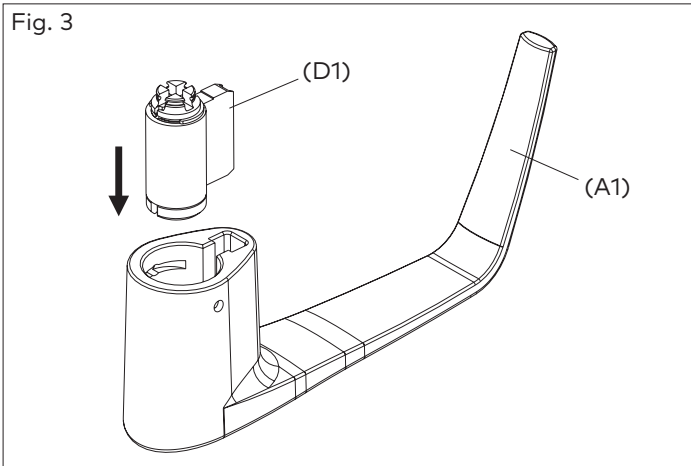

4. Put the cylinder plug (C1) into the lever (A1) (see Fig.4)

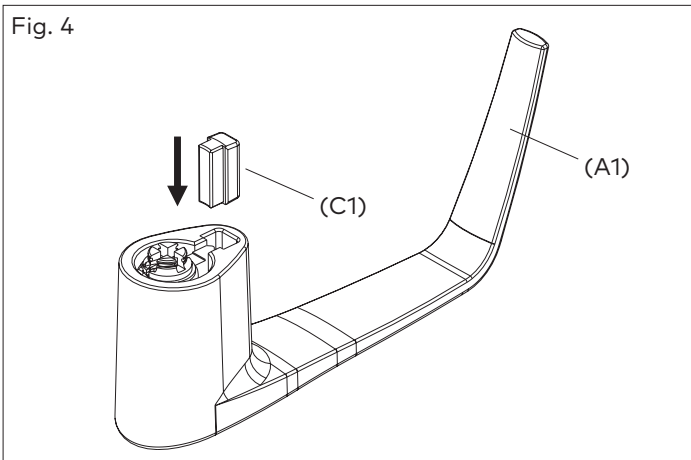

5. Insert key (L1) into cylinder (D1). Hold plug (C1) in position. (See Fig. 5).

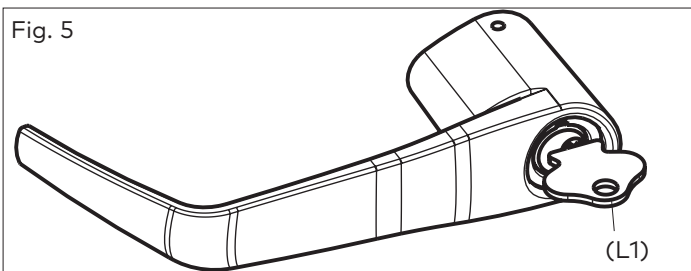

4.4 Steps to attach the lever handle to the lock housing

***NOTE: the position of the key is very important**

6. Right-handed Lever handle: Turn the key (L1) approximately 100° clockwise so that it is in the vertical position and the recess entry for key is in the top position. (See Fig. 6)

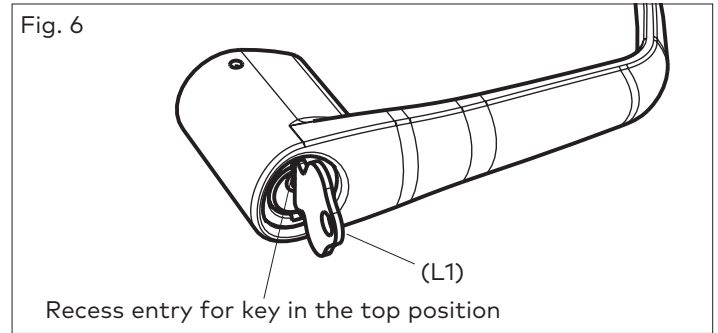

Left-handed lever handle: Turn the key (L1) approximately to 100° clockwise so that it is in the vertical position and the recess entry for key is in the bottom position. (See Fig. 7)

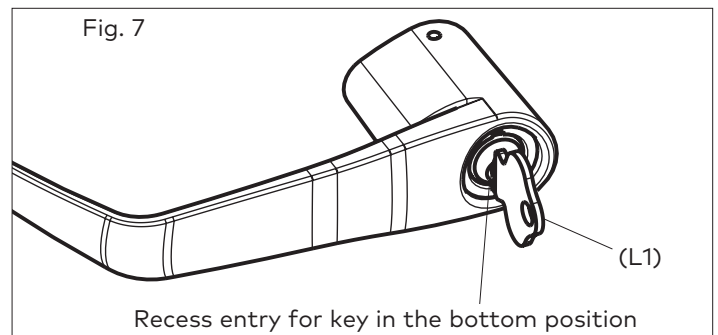

IMPORTANT

The key (L1) and the recess entry for key must be in the positions shown in Figs 6 & 7 before placing the lever handle on the housing or the lever and the override mechanism will not work

Troubleshooting:

If you have assembled the lever and housing with the key (L1) in the wrong position, the key (L1) will get stuck. To remove the key (L1), turn it so that it is in the vertical position and insert a small flat screwdriver (M1) (see page 17) into the hole under the lever handle to push Lever Catch (J1) in (Fig.2). Remove lever, remove key. If it is still stuck, turn the key 90° clockwise to the horizontal position and push the Lever Catch (J1) in again with the small screwdriver (M1). Remove key (L1).

⚠ CAUTION

If the lever is not assembled with the key in the position shown in Fig. 6 & Fig. 7, the inside mechanism of the lock could be damaged if the lever is rotated and forced.

4 Installation of Mechanical Override Model

4.5 Attaching the Lever Handle to the Lock (with the key as shown in Fig. 6 & Fig. 7)

7. Fit the lever handle (A1) onto the drive tube (I1). It should rest approximately 1/8" from the body of the housing. If not, wiggle and jiggle key (L1) to align cylinder (D1) with override shaft (K1) (See Fig. 8)

If the lever catch (J1) can't be pushed close to the housing, it is probably not pushed in. Push it in. (see fig 2 page 13)

If the lever catch (J1) is stuck, the override shaft (K1) is in the wrong position. (see fig 2 page 13) The two small indents (N1) on the cross of the override shaft (K1) must be vertically aligned as in fig 2 page 13

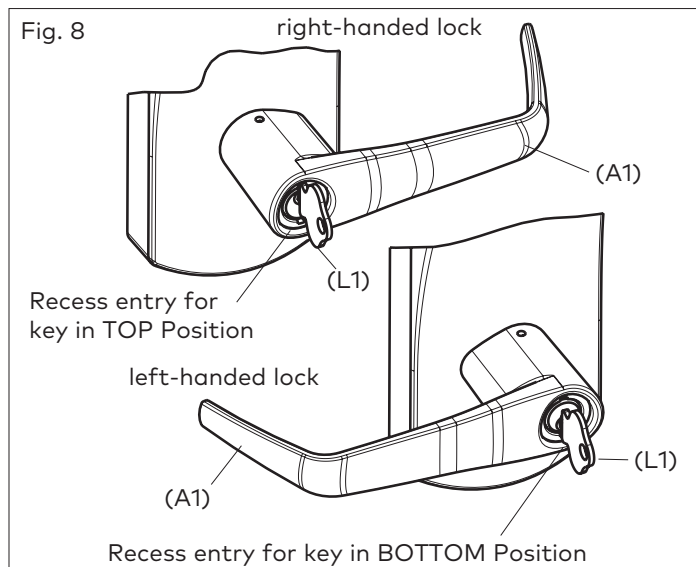

8. Press the lever (A1) firmly against the housing while turning the key (L1) counterclockwise (**this applies to both right-handed and left-handed locks**) until it is in the horizontal position. (Fig. 9)

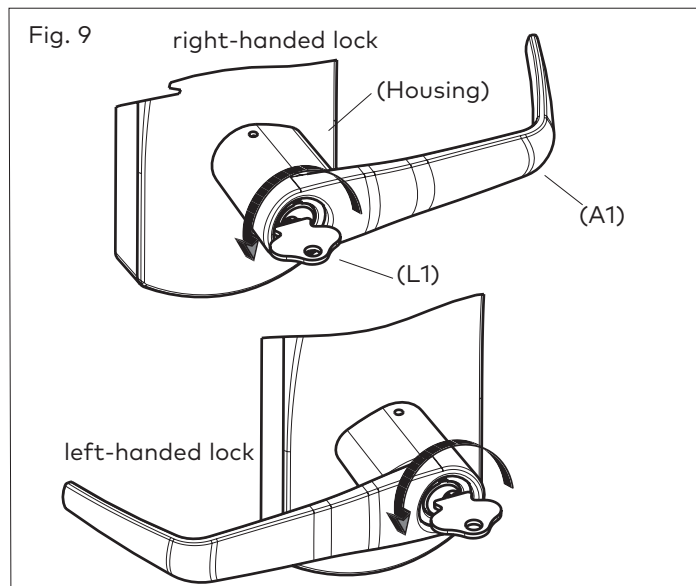

IMPORTANT

If it is not possible to turn the key (L1) counter-clockwise to complete this step, the spring washer (H1, see page 12) may be too tense:

Hit the lever carefully with a rubber mallet to loosen the spring washer (H1). (you may want to cover the lever handle (A1) with a cloth or other material to protect the finish of the metal)

9. Remove the key (L1). The lock will look as shown in Fig.10.

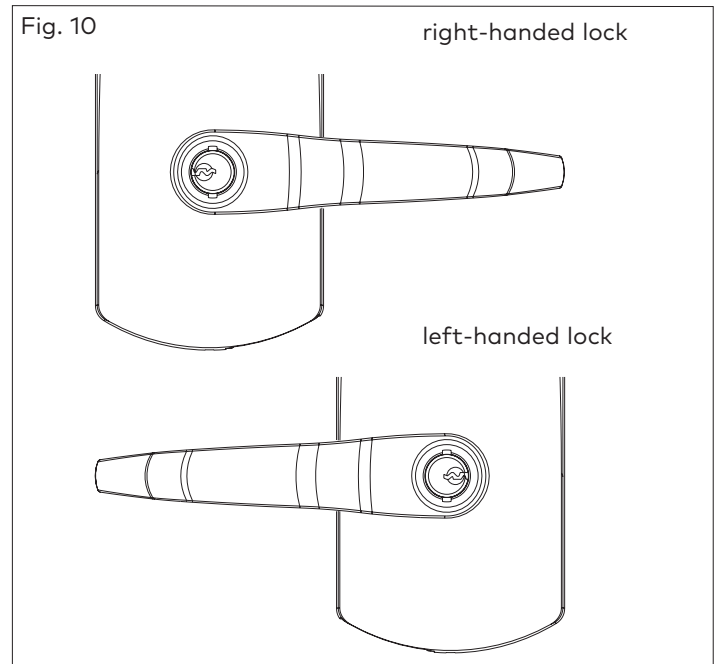

Gently check the rotation of the lever handle (A1). It should easily rotate approximately 45°.

Troubleshooting:

Right-handed Lock: Turn the lever handle (A1) clockwise without forcing it. If it stops at approximately 15°, it was not assembled correctly as shown in step 6 (Fig. 6 & 7). **Do not try to force it to turn.** Release the lever handle (A1). Insert the small screwdriver (M1, page 16) into the small hole on the underside of the lever handle (A1) and push in the lever catch (J1) see page 13. Re-do steps 2, 3, 4 & 5.

Left-handed Lock: Turn the lever handle (A1) counter-clockwise without forcing. If it stops at approximately 15°, it was not assembled correctly as shown in step 6 (Fig. 6 & 7). **Do not try to force it to turn.** Release the lever handle (A1). Insert the small screwdriver (M1, page 16) into the small hole on the underside of the lever handle (A1) and push in the lever catch (J1) see page 13. Re-do steps 2, 3, 4 & 5.

4 Installation of Mechanical Override Model

4.6 Verify the attachment of the lever handle

IMPORTANT

Very Important: To verify that the lever handle has been correctly attached to the housing:

10. Remove key (L1)
11. Insert a small flat screwdriver (tool M1, page 12) into the hole on the underside of the lever handle (A1) and push in the lever catch (J1) as per fig 11.
12. Pull on the lever handle (A1).

You should not be able to remove the lever handle (A1). If it comes off of the housing, you did not assemble the lock correctly. Return to steps 2, 3, 4 & 5 and make sure that the lever (A1) looks like Fig. 10 and repeat this verification process. (Step 10)

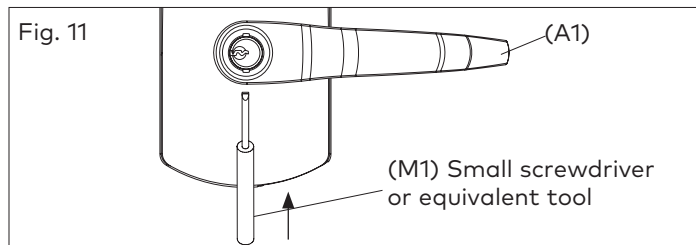

4.7 Adjust the lever feel

13. If applicable, to reduce the lever play, using the 5/64 allen key (P1), tighten the set screw (O1) while pushing the lever against the front housing. Make sure the lever rotates properly after tightening the set screw (O1). See fig 12.

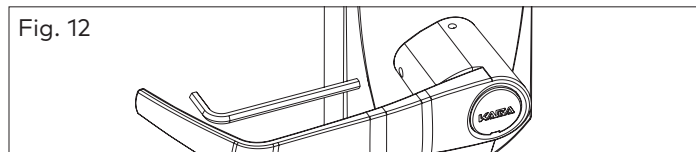

4.8 Test the movement of the lever handle (remove the key (L1) in cylinder (D1))

14. Turn the handle (A1) clockwise (for a right-handed lock) or counter-clockwise (for a left-handed lock)
15. Release the handle (A1) slowly. It should return freely to its horizontal position. (Fig.13)

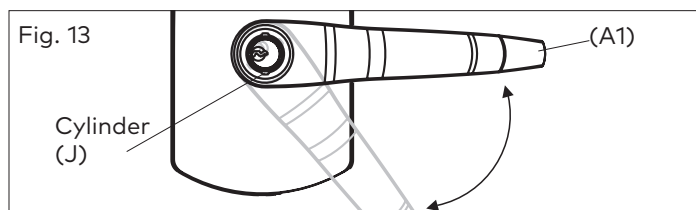

16. If the handle (A1) doesn't easily return to its original position, the spring washer (H1) (page 12) is probably too tight. Use a rubber mallet to hit the lever (A1) carefully against the housing to reduce the tension of the spring

washer (H1), until the handle (A1) moves freely back to its horizontal position when turned slowly.

4.9 Test the mechanical override function

IMPORTANT

This test can only be performed when the lock is not affixed to the door.

17. Without using the key (L1), turn the lever handle (A1) clockwise (for Right-handed locks) or counter-clockwise (for Left-handed locks). The inside drive hub (F1) should not rotate when the handle (A1) turns. (Fig. 14)

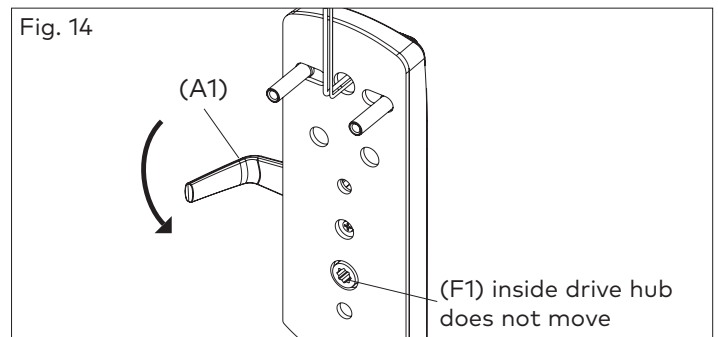

18. With the lever handle (A1) in the horizontal position, insert the key (L1) into the cylinder (D1) and turn it clockwise until it stops. (This applies to both Right and Left-handed locks, see Fig.15)

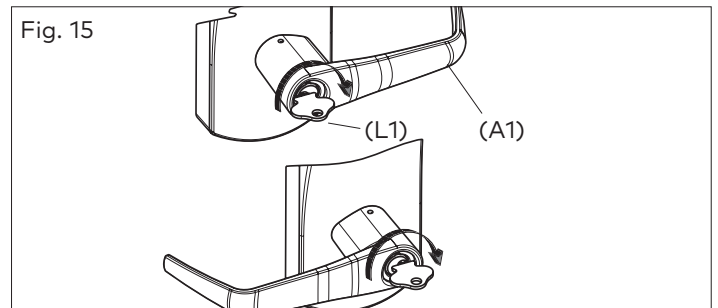

19. Hold the key (L1) in stopped position (should be a bit more than vertical) and turn the lever handle (A1) clockwise (for Right-handed locks) or counter-clockwise (for Left-handed locks). The inside drive hub (F1) should rotate in the same direction as the lever handle (A1) when it is turned. (Fig. 16)

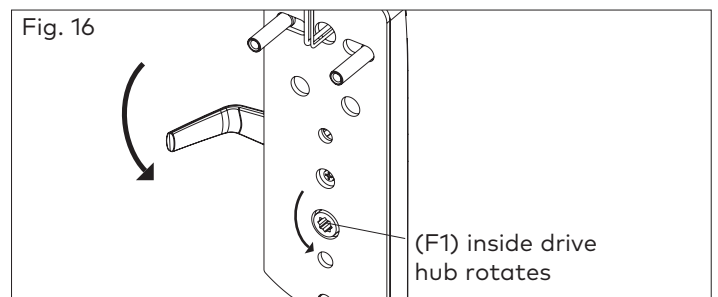

4 Installation of Mechanical Override Model

Test the Mechanical Override Function (continued)

IMPORTANT

Verify the functionality of the mechanical override after the lock is installed on the door: (Door must be opened)

20. With the door open, insert key (L1) in cylinder (D1) and turn it clockwise **until it stops**.
21. Hold the key (L1) in stopped position (should be a bit more than vertical) and turn the lever handle (A1) (clockwise for right-handed and counter-clockwise for left-handed locks). **The latch must retract**.
22. Extend deadbolt and repeat the above operation (turn key (L1) clockwise until it stops), latch and deadbolt must retract completely.

4.10 Cover the keyhole & cylinder with the cap

23. The cap (E1) has a small groove on one edge (to allow ease of removal) this should be facing down. Insert bottom snap of cap (E1), in handle hole below the cylinder (D1). With a small screwdriver, push the top snap of the cap down while pushing the cap (E1) into place to cover the keyhole (Fig. 17)

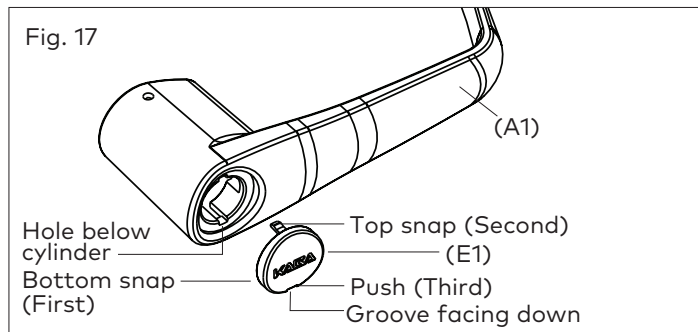

24. To remove the cap (E1), insert a small flat screwdriver into the groove and gently pry the cap off, being careful not to damage it. (You may want to cover the bottom of the lever to protect the finish from being scratched through the process of removing the cap). (Fig.18)

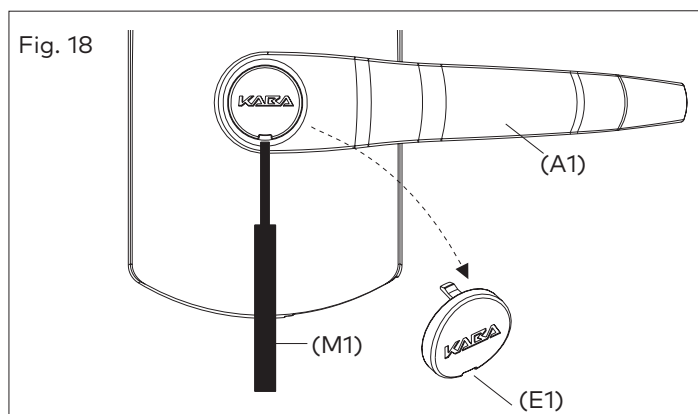

4.11 How to change lock cylinders

25. Loosen the set screw (O1) to free the lever using Allen Key (P1) (Approx. 1/4 turn). See fig 12 page 16
26. Remove the cap (E1) from the lever handle (A1) (see step 24, Fig. 18).
27. Insert key (L1).
28. Turn the key (L1) clockwise until it stops.
29. Release key (L1).
30. Use a small flat screwdriver to push in the lever catch (J1) through the small hole underneath the lever handle (A1) (Fig. 19).

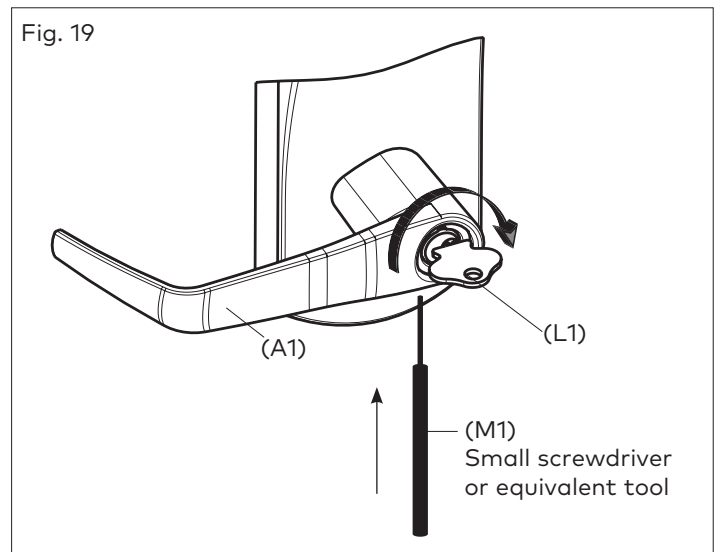

31. Pull the lever handle (A1) off of the lock housing (be careful not to lose the cylinder plug (C1)).
32. Replace the old cylinder with the new one in the lever handle (A1). Only the same kind of cylinder with 2 grooves in a cross in the end of the cylinder plug, could be used on the locks. (Fig. 20)

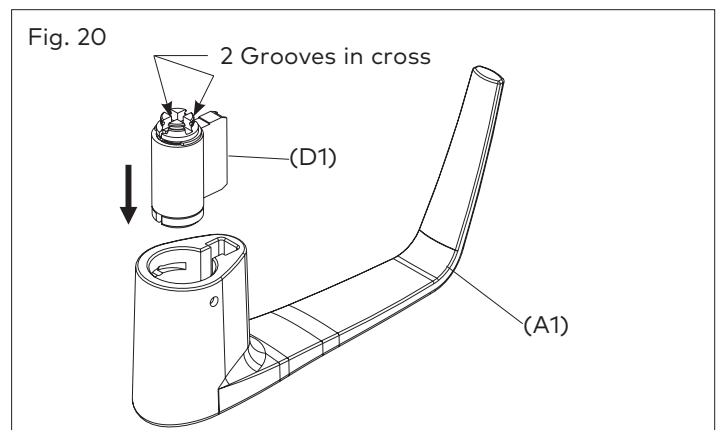

4 Installation of Mechanical Override Model

How to change lock cylinders (continued)

33. Re-insert the cylinder plug (C1) (Fig. 21)

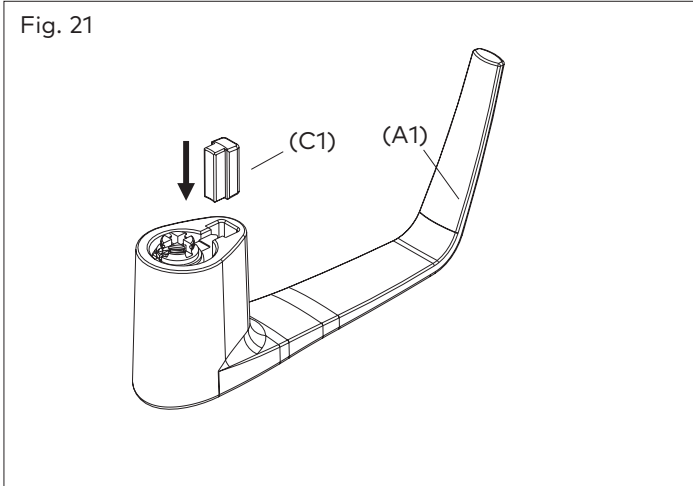

34. While holding the cylinder (D1) and plug (C1) in place, insert the key (L1) (see Fig. 22)

35. Turn the key (L1) approximately 100° clockwise

36. Repeat the steps 1 to 9 to attach the lever handle (A1) to the lock housing. (see Fig. 22)

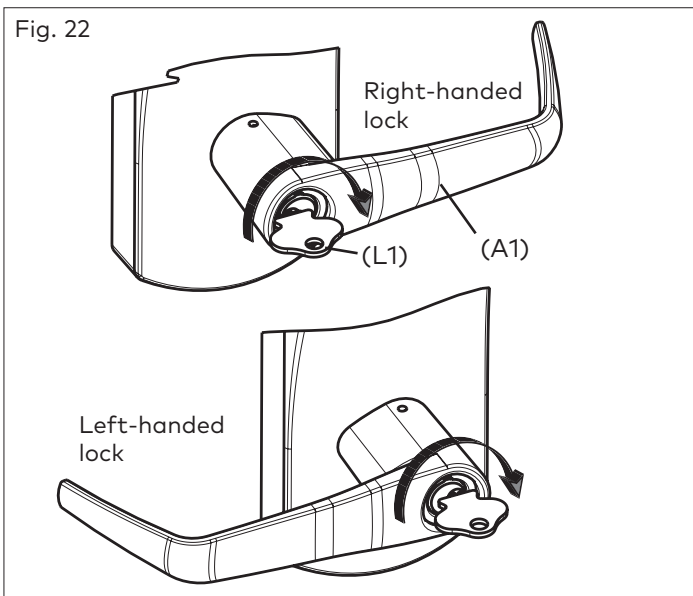

IMPORTANT

The Key Override itself does not retract the latch or dead-bolt. Do not use too much force when turning the key as this may damage the unit. To retract the latch, turn the key clockwise until it stops, and turn the lever handle (A1). See page 15

⚠ WARNING

The lever handle must stay in the horizontal position when turning the key (do not try to turn the key while turning the handle) or the override mechanism will not work.

IMPORTANT

Always keep the door open while installing and verifying the functionality of the lock with the keycard or key override. Do not close the door until you are certain that you have installed the unit correctly.

4 Installation of Mechanical Override Model

4.12 The Recodable Cylinder with 3 different keys

IMPORTANT

Read the following instructions before using any of the 3 keys supplied

The recodable cylinder can be operated with three different keys. The keys are numbered 1, 2 & 3, and each key is labeled and supplied in a separate plastic bag. It is very important to use them in order.

*** Always read the label instructions on the label before using a key.**

CAUTION

The use of key #2 automatically cancels the function of key #1, and the use of key #3 automatically cancels both keys #1 and #2.

If key #3 is used first, it will immediately make keys #1 and #2 unusable.

Once a key is cancelled, it can't be reactivated unless the cylinder itself is re-pinned.

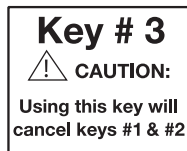
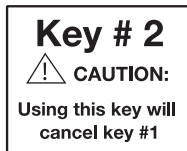
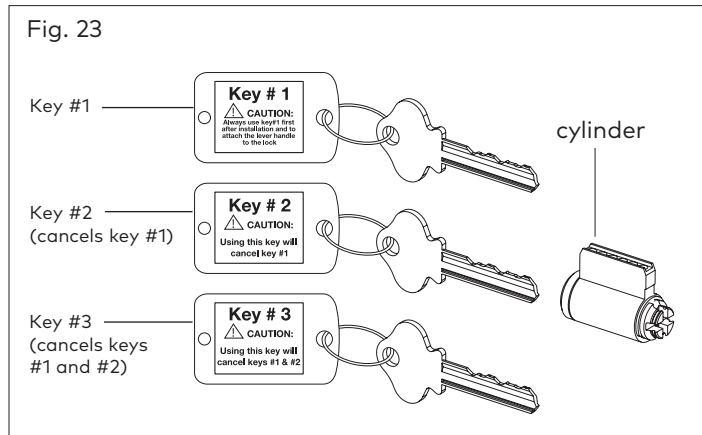

How to change lock combination from key #1 to key #2:

37. Insert key #2 into cylinder.
38. Turn the key clockwise until it stops (see Fig. 24) for both left-handed and right-handed locks.

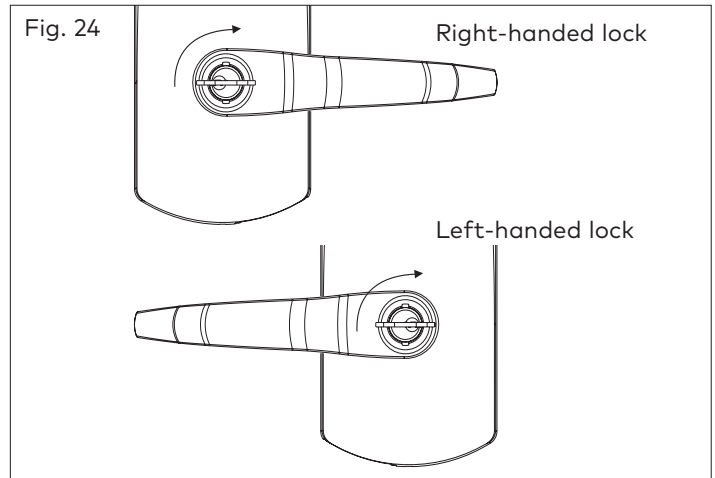

39. Turn the key back counter-clockwise until it is in the horizontal position.

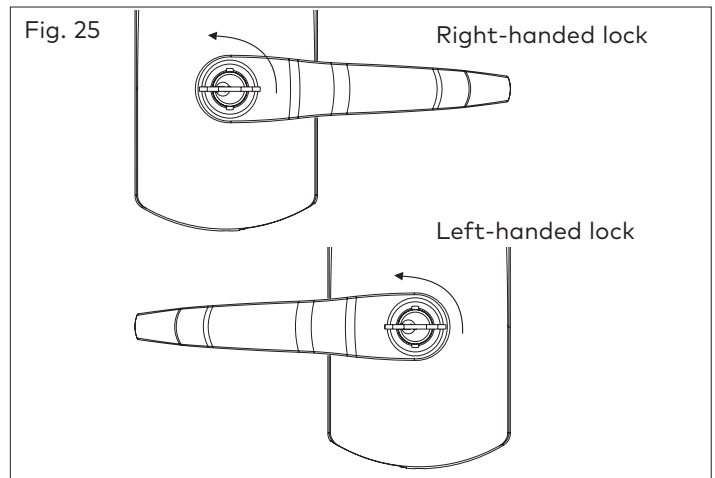

40. Remove the key.
- Now the lock should work with key #2, and key #1 has been cancelled.

***Test: Try to use key #1 in the lock. It should no longer work.**

How to change lock combination from key #2 to key #3

41. Insert key #3 into cylinder.
 42. Turn the key clockwise until it stops.
 43. Turn the key back counter-clockwise until it is in the horizontal position.
 44. Remove the key.
- Now the lock should work with key #3, and key #2 has been cancelled.

***Test: Try to use key #2 in the lock. It should no longer work.**

APPENDIX A.1 Reversing the Mortise Handing on ASM 1 1/4" Face Plate Only

A.1.1 Reversible ASM

1. Place the mortise on a flat surface.
2. Partially extend the deadbolt:

For normal ASM, rotate hub (D4) using a screwdriver, until the deadbolt (D5) extends approximately 1/4".

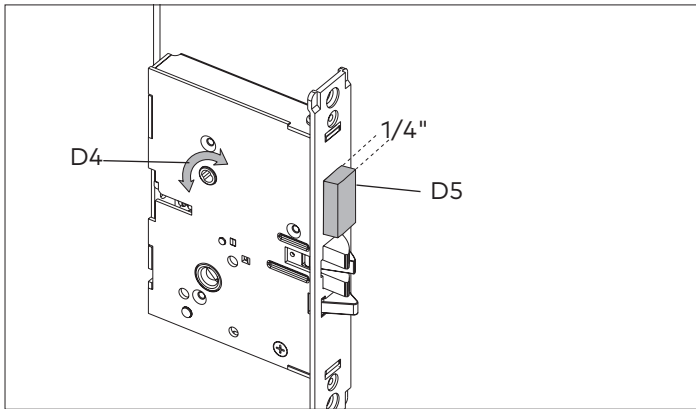

Proceed to step 3.

For Autodeadbolt ASM, rotate hub (D4) until the deadbolt (D5) is fully retracted. The deadbolt will extend approx. 1/16" from the mortise case.

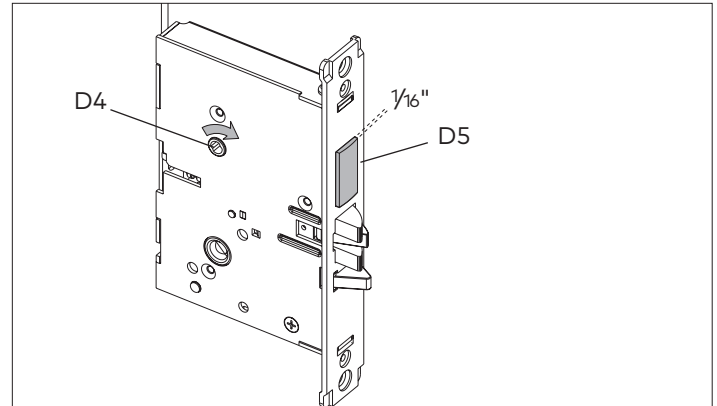

Hold the deadbolt (D5) gently. Press and release the auxiliary latch (D6). You should feel the deadbolt trigger and begin to extend under the force of the spring.

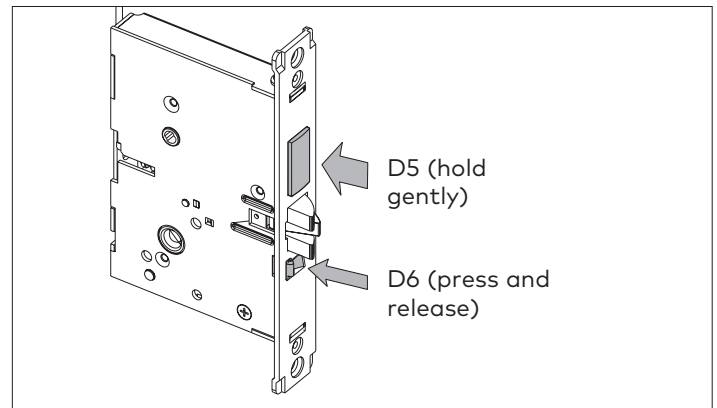

Release the deadbolt (D5) gently. It should extend to approximately 5/16" and stop. If the deadbolt extends past this point, gently press it in until it locks at a protrusion of approximately 5/16" or start step 2 again.

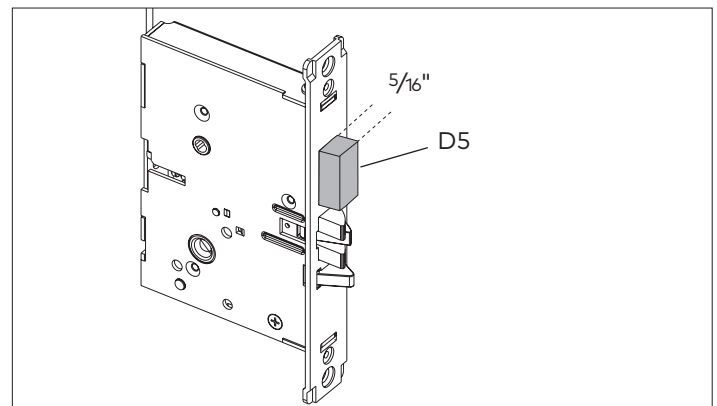

APPENDIX A.1 Reversing the Mortise Handing on ASM 1 1/4" Face Plate Only

A.1.1 Reversible ASM (continued)

3. Push in the latch bolt (D7) to the middle of its stroke, and hold it there.

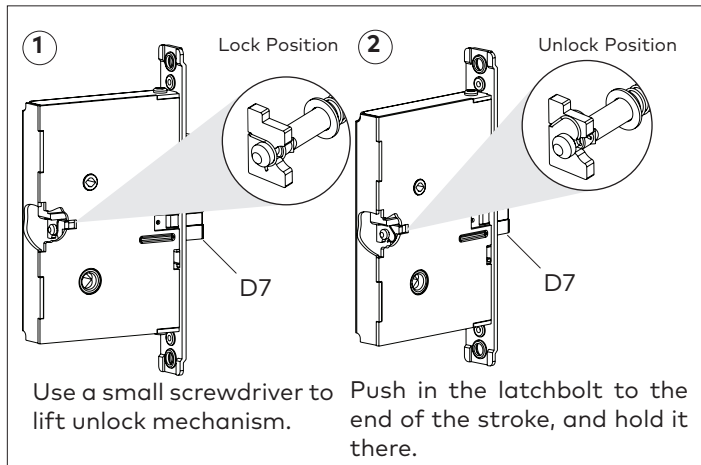

4. Hold the latch (D7) inside the mortise, and insert the tailpiece retaining tool (D8, part #027-510382 available separately) so that the tailpiece (D10) will not drop inside the mortise case. Hold the tool and the latch with one hand, and slide up the tailpiece using a small screwdriver.

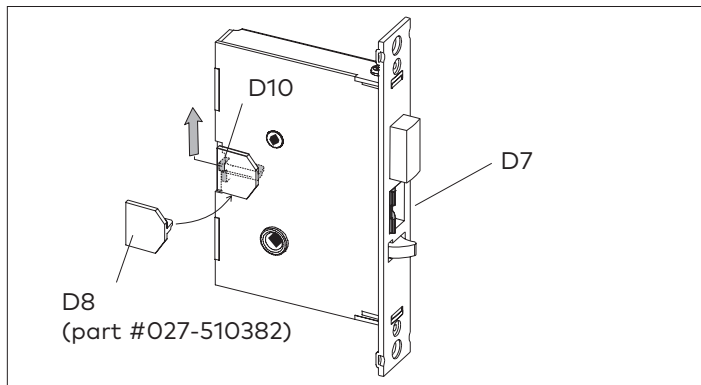

5. Continue to hold the retaining tool (D8). Release the latch bolt (D7) and keep the anti-friction latch (D9) toward the flat side of the latch bolt so that the bolt extends fully.

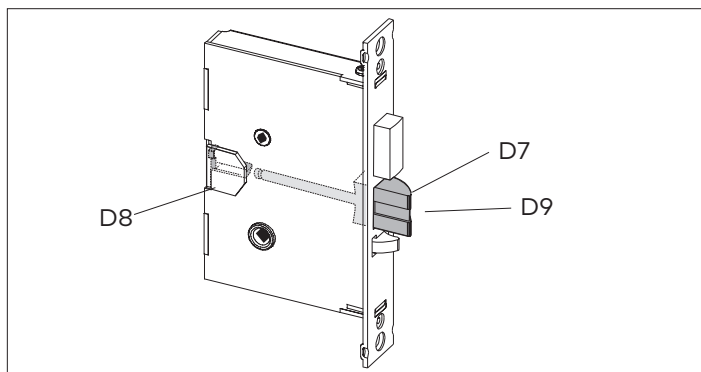

6. Pull out the latch bolt (D7), until it just clears the front plate. (Note: If you remove the bolt completely, you must turn it 90° to re-insert it.)

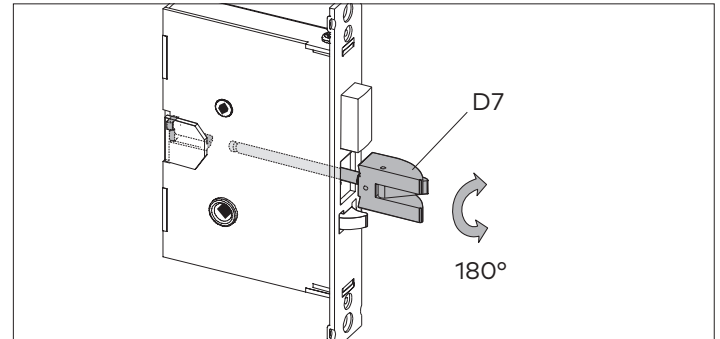

7. Rotate the latch bolt (D7) 180°. Re-insert it to the end of its stroke.

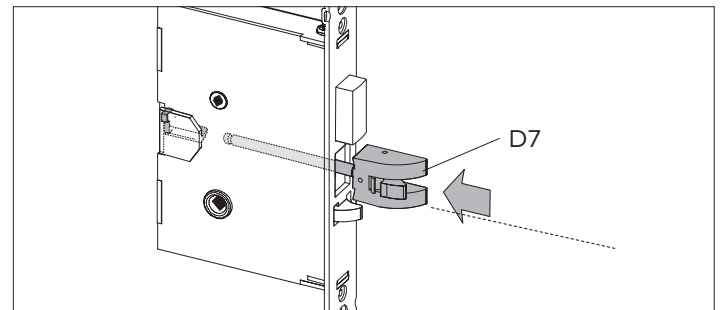

8. Holding the retaining tool (D8) in place, re-engage tailpiece (D10) with the latch bolt (D7). There may be some play required to align the parts. Remove the tool (D8).

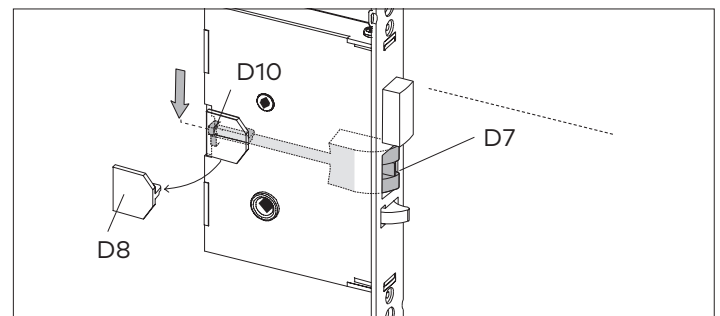

9. Release the latch to the middle of the stroke and hold it there. Use a small screwdriver to push the lock mechanism back to the locked position.

IMPORTANT

The lock mechanism has to be horizontal on the locked position

APPENDIX A.1 Reversing the Mortise Handing on ASM 1 1/4" Face Plate Only

10. Release the latch bolt (D7). Position the latch bolt so that the bottom tooth of the anti-friction latch (D9) remains inside the mortise case as shown.

2. If deadbolt is projected, retract the deadbolt (D5) as shown by turning the hub (D4) with a small screwdriver, then push in the latch bolt (D7) to the end of its stroke.

IMPORTANT

If the tooth of (D9) is outside the mortise, you will not be able to re-assemble the faceplate on the mortise.

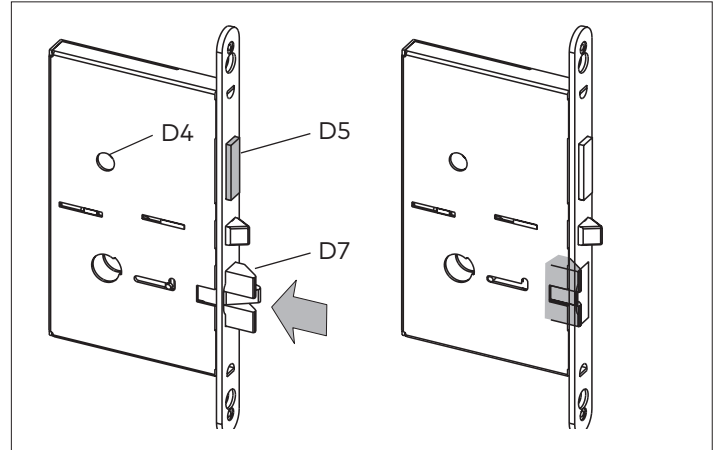
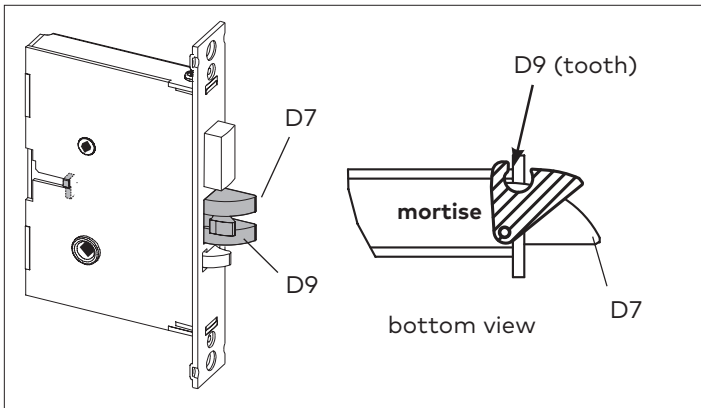

3. Release the latch bolt, and guide anti-friction latch (D9) against the flat side of the latch bolt so that it will slide out of the mortise beyond its normal throw.

A.1.2 Reversible ESM

1. Remove the mortise faceplate, and place the mortise on a flat surface for the following steps.

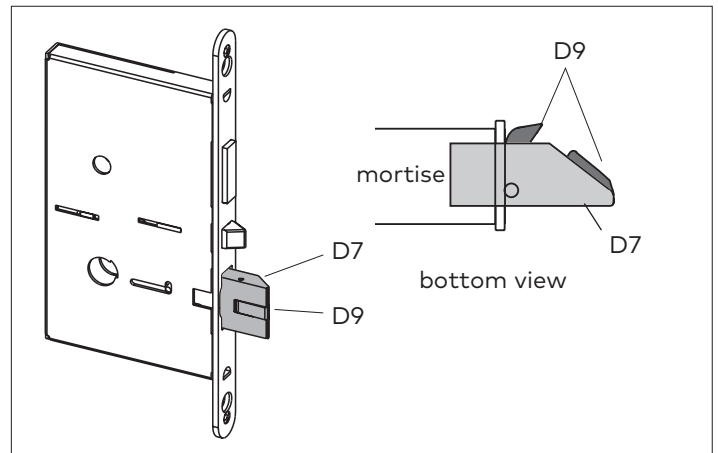
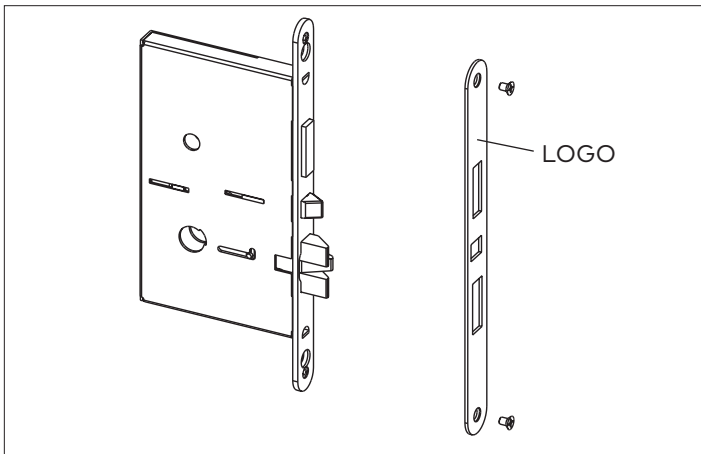

APPENDIX A.1 Reversing the Mortise Handing on ASM 1 1/4" Face Plate Only

4. Using a small screwdriver, slide up the locking pin (D11). Pull out and remove the latch bolt (D7), rotate it 180°, and reattach it.

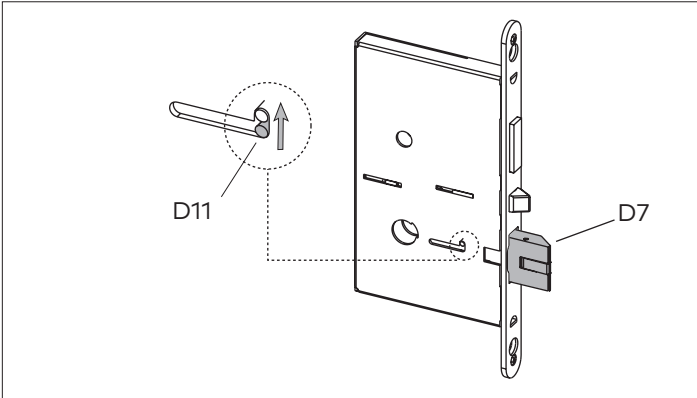

6. Push in the latch bolt (D7) to the end of its stroke.

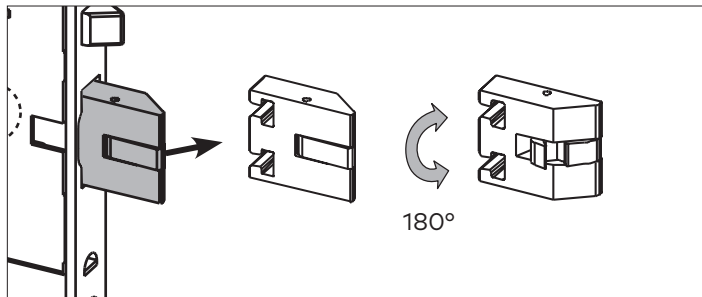
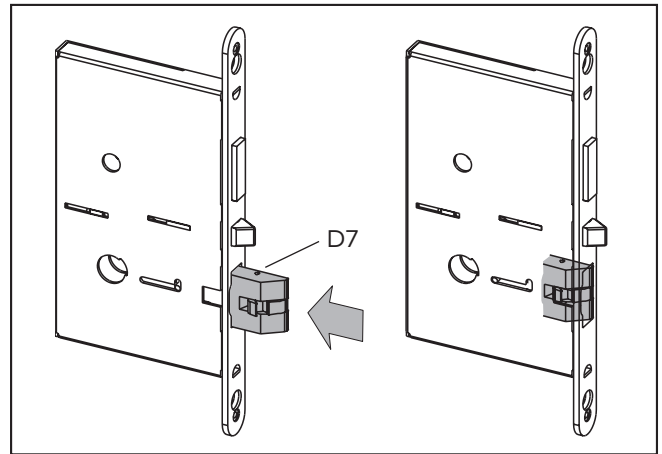

5. Re-insert the rotated latch bolt (D7) until it stops. Push down the locking pin (D11) to lock the latch bolt in the mortise.

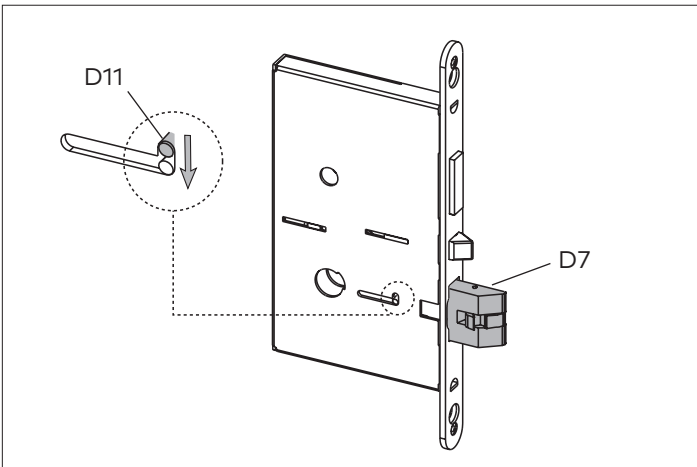

7. Release the latch bolt (D7) while positioning the anti-friction latch (D9) so that it will remain inside the mortise. Ensure the bottom tooth of the anti-friction latch (D9) remains inside the mortise case as shown.

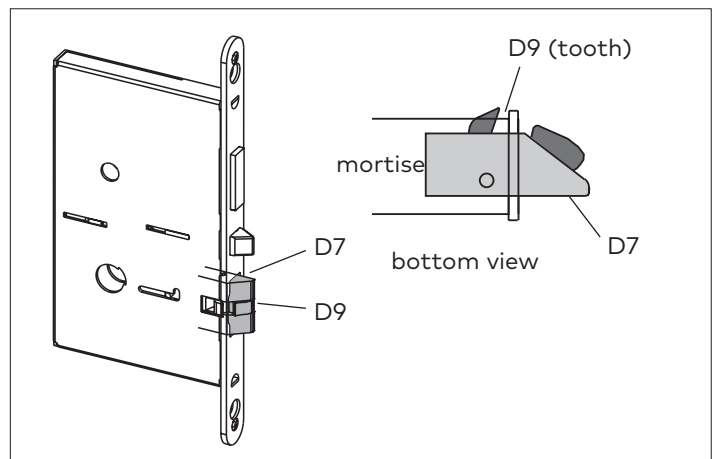

IMPORTANT

If the bottom tooth of (D9) is outside the mortise, you will NOT be able to re-assemble the face plate on the mortise.

The ESM face plate must be installed so you can read the logo.

APPENDIX A.2 Additional steps for Autodeadbolt ASM

Do the following **INSTEAD OF** page 10, step 6:

5. If not already installed at the factory, **put the thumbturn in the vertical position and install all four (4) parts (E)** as shown, on the inside trim assembly.

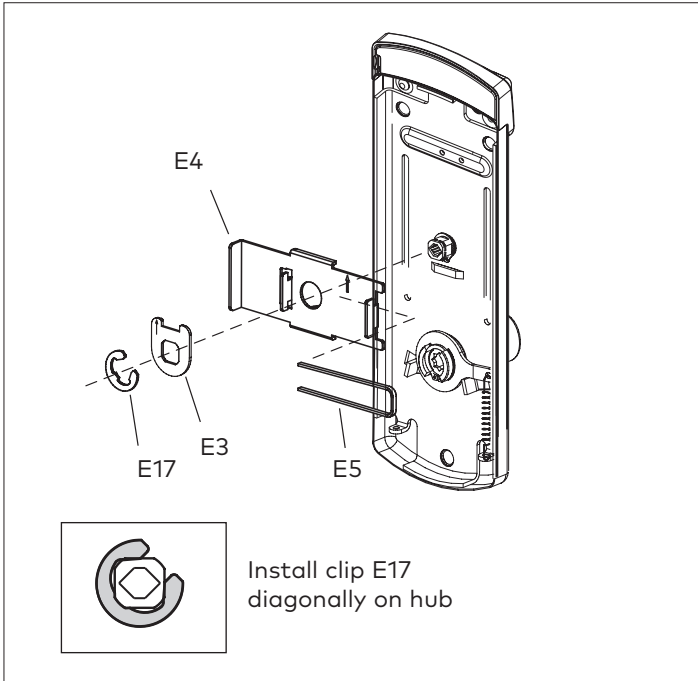

Turn the thumbturn all the way to the right for a RH installation (arrow on E3 points UP), or all the way to the left for a LH installation (arrow on E3 points DOWN). The thumbturn should stop in the vertical position, and the stopper cam (E3) will be in the position illustrated below.

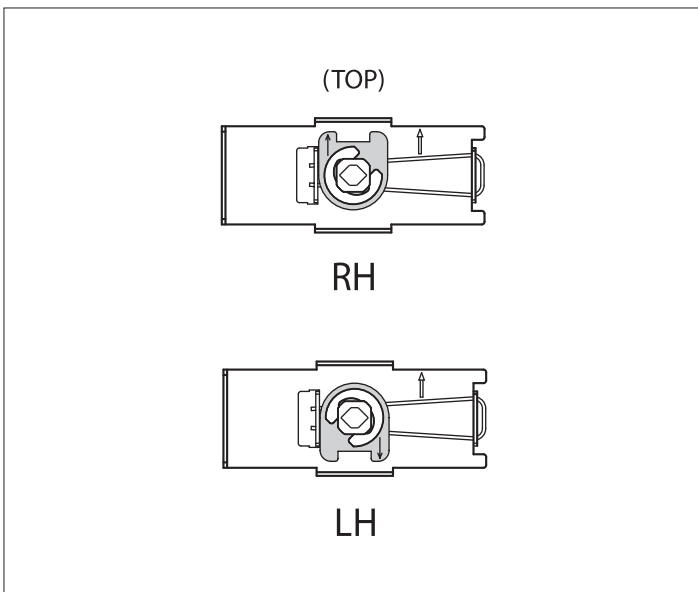

Place the 3 spacers (S) on the door. Place the inside trim assembly on the door so that the upper and lower spindles (F) and (G) engage the thumbturn and the inside lever. Fasten to the outside housing using the three 1/8" hex head mounting screws (I).

If applicable apply the privacy thumbturn sticker as shown. If in doubt as to the direction of the arrow, press the auxiliary latch (D6) to extend the deadbolt, and verify in which direction to rotate the thumbturn to reach the horizontal (privacy) position.

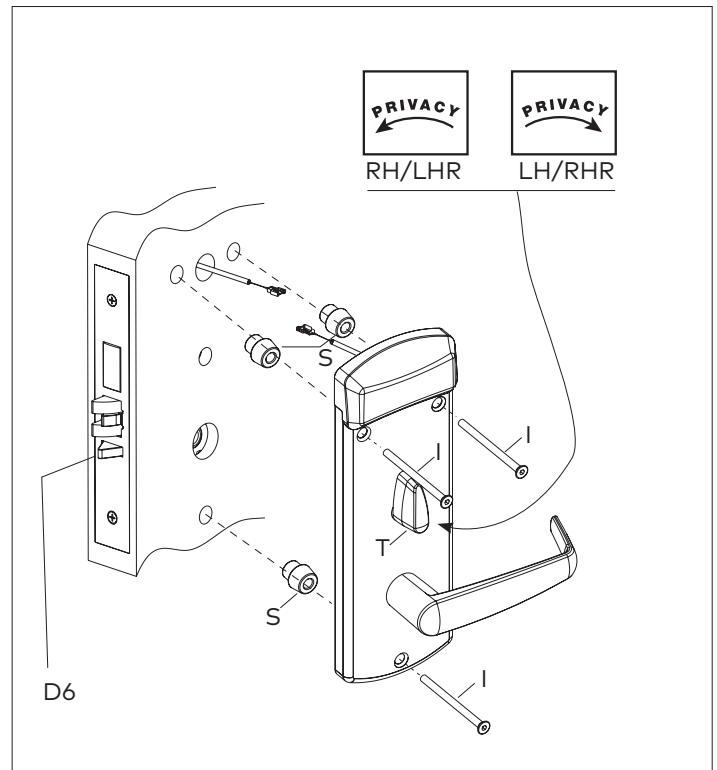

APPENDIX A.3 Additional steps for ASM Office

Do the following **BEFORE** placing the inside trim assembly on the door (page 10, step 7):

Install only parts (E4 and E5) as shown, on the inside trim assembly.

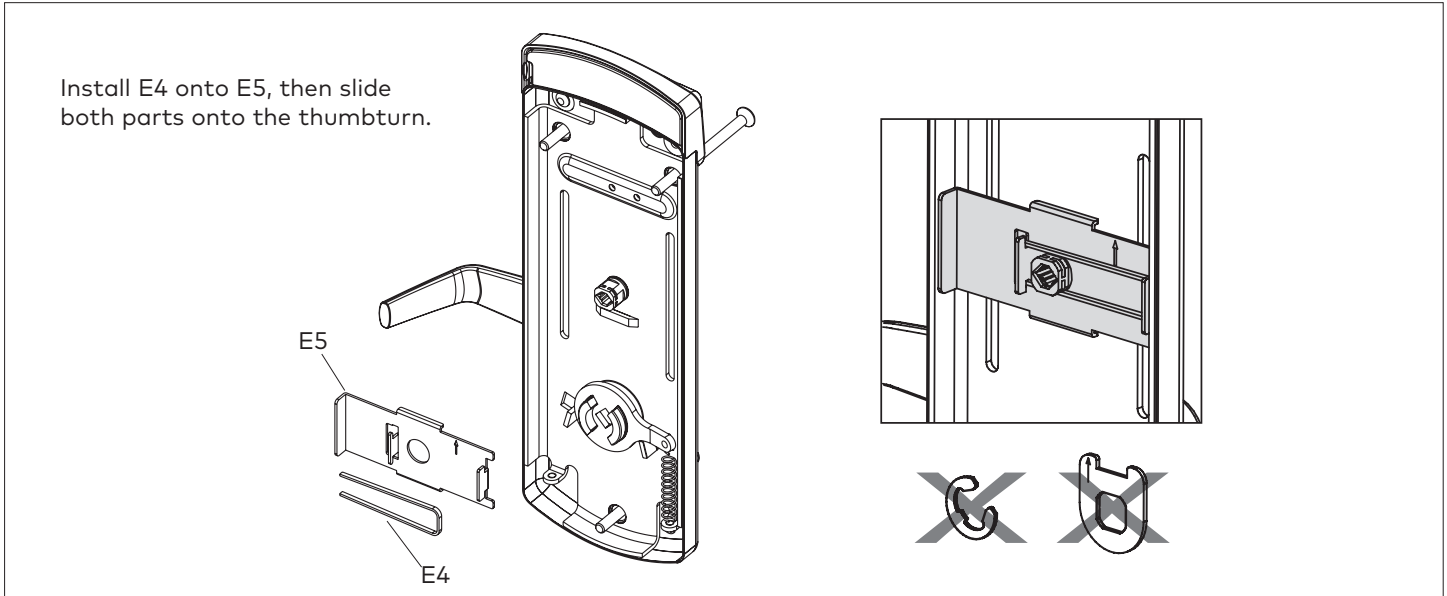

APPENDIX A.4 Additional steps for ASM/ESM Storeroom

Do the following **BEFORE** placing the inside trim assembly on the door (page 10, step 7):

Put the thumbturn in the vertical position and install only parts (E17, E3 and E5) as shown, on the inside trim assembly. The notch on the stopper cam (E3) must engage the tab on the plate (E5), so that the thumbturn is locked in the vertical position.

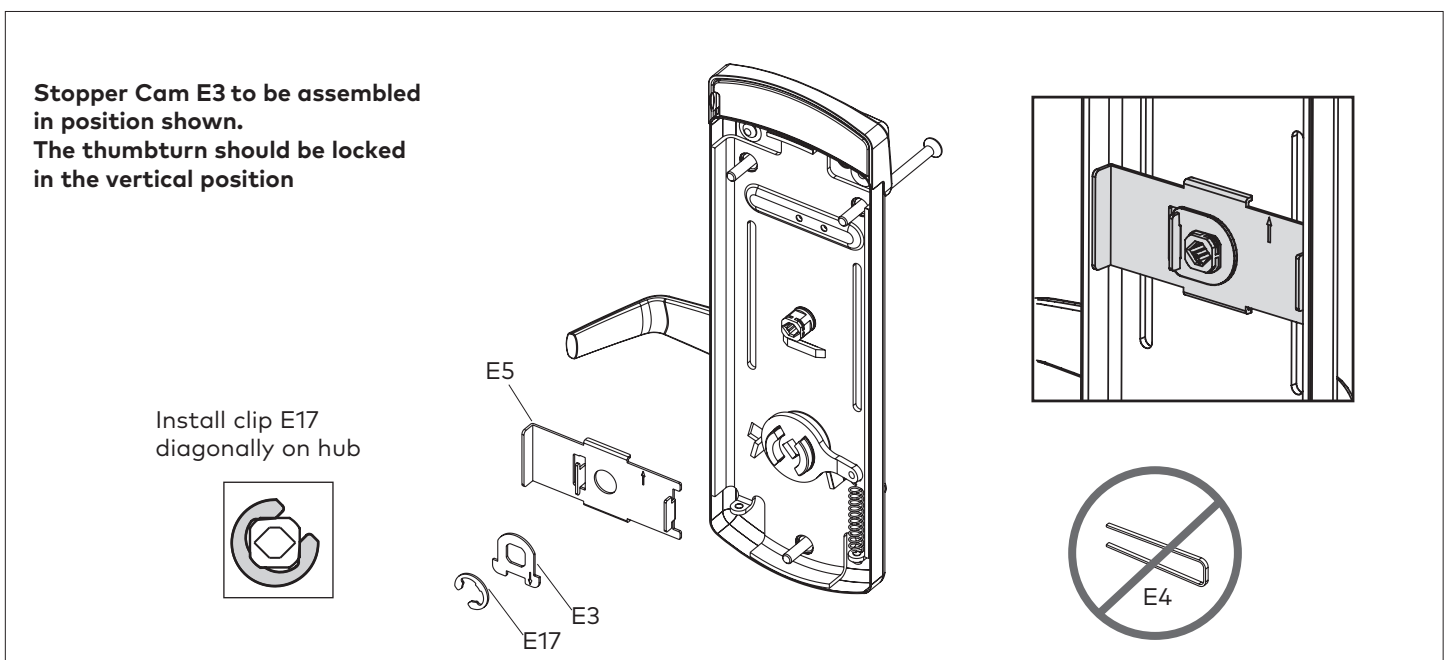

APPENDIX B Installing Cylindrical Models 2³/₈" & 2³/₄" Backset

B.1 Install the Strike

Follow the same steps as for a mortise model strike (see page 8, all steps in section 3.2). Note that the handle height is aligned with the center of the strike.

IMPORTANT

For cylindrical latch models, ensure the dead-locking pin will stop against the strike when the door is closed (see figure). An incorrect installation that permits the pin to slip inside the strike may result in a total lockout and will void the warranty of the complete lock mechanism.

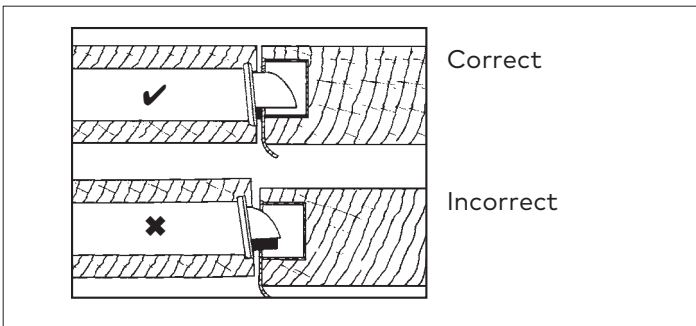

B.2 Install the Latch

Follow the instructions on page 9, all steps in section 3.3.

Note that for cylindrical models, the axis of rotation of the handle is level with the center of the strike. Mark this height on the edge of the door in step 1 on page 8.

IMPORTANT

Respect applicable building codes regarding handle height.

1. Drill the hole for the latch, and chisel out clearance for the latch plate according to the template.
2. Drill the holes for the cylindrical unit, thumbturn spindle, and lock mounting screws. Refer to template for dimensions and depths.

IMPORTANT

Drill from both sides of the door to prevent unsightly damage.

3. Install the latch (O) using 1" Phillips mounting screws. Position the deadlocking pin (Q) opposite to the closing direction as shown.

4. Install strike and strike dust box.

IMPORTANT

Use only the strike and strike box supplied. The use of non-approved parts will result in a functionality problem and may void the warranty.

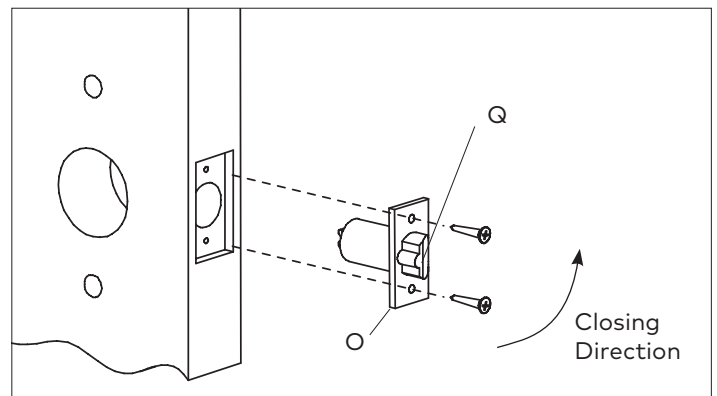
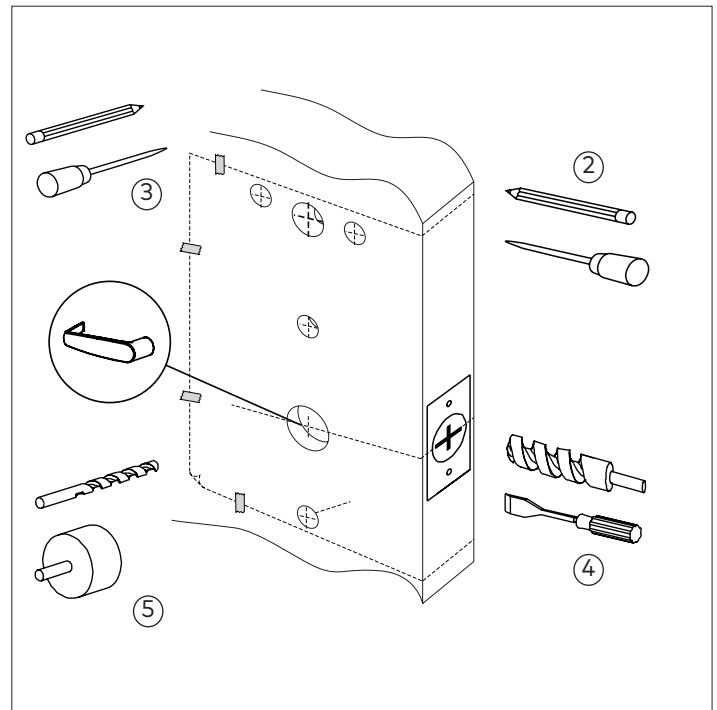
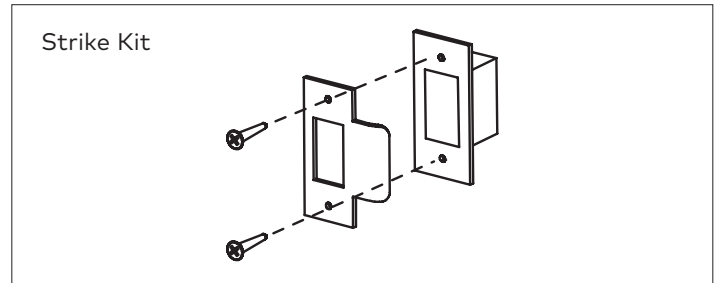

APPENDIX B Installing Cylindrical Models 2³/₈" & 2³/₄" Backset

B.3 Install the Cylindrical Unit

The lock is factory shipped with spacers for doors of 1 ³/₄" thickness. For doors of other thicknesses remove the two screws (06 of fig. 2) and as per table 1 install the required components (06), (07) and (08) as indicated.

IMPORTANT

It is very important to assemble the spacers in position shown.

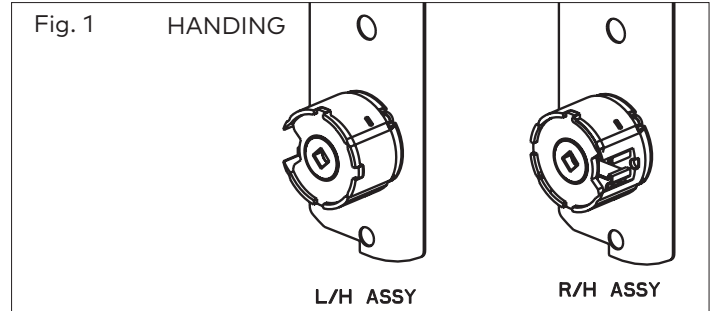

1. Lock with 2 DIFFERENT SPACERS (see fig. 2) The cylindrical Unit and Attachement Plate assembly is shipped assembled in the factory for 1 ³/₄" door thickness (44mm) with 2 "07" spacers, 1 "08" spacer and 2 "06" ⁵/₈" LG (see fig.4) flat head screws.

Door Thickness	Spacer 07	Spacer 08	Screw 06
1-3/8" (35mm) to 1-9/16" (40mm)	2	-	3/8 (10mm)
1-5/8" (41mm) to 1-11/16" (43mm)	1	1	1/2 (13mm)
1-3/4" (44mm) to 1-13/16" (46mm)	2	1	5/8 (16mm)
1-7/8" (48mm) to 1-15/16" (49mm)	-	2	5/8 (16mm)
2" (51mm) to 2-1/16" (52.5mm)	1	2	3/4 (19mm)
2-1/8" (54mm) to 2-3/16" (56mm)	2	2	3/4 (19mm)
2-1/4" (57mm) to 2-5/16" (59mm)	-	3	7/8 (22mm)
2-3/8" (60mm) to 2-1/2" (64mm)	1	3	7/8 (22mm)

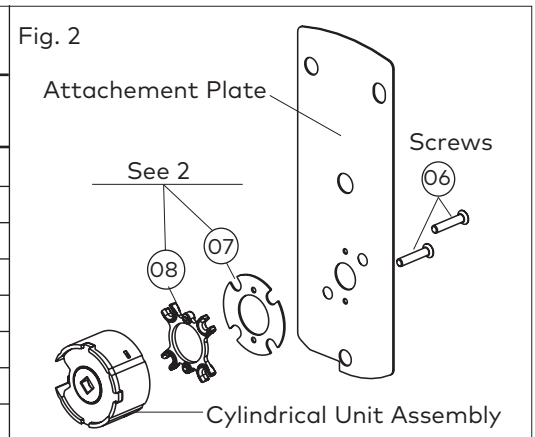
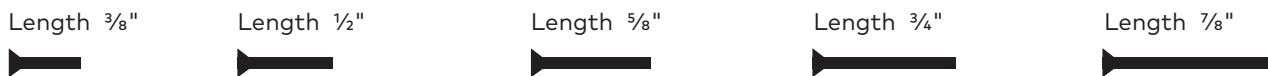

Fig. 3

Screw Length (Full Scale)



APPENDIX B Installing Cylindrical Models 2³/₈" & 2³/₄" Backset

B.3 Install the Cylindrical Unit (con't)

2. Insert the cylindrical unit from the outside of the door towards the inside, so that it engages the latch as shown. This operation is to be done at B.5 step 4.

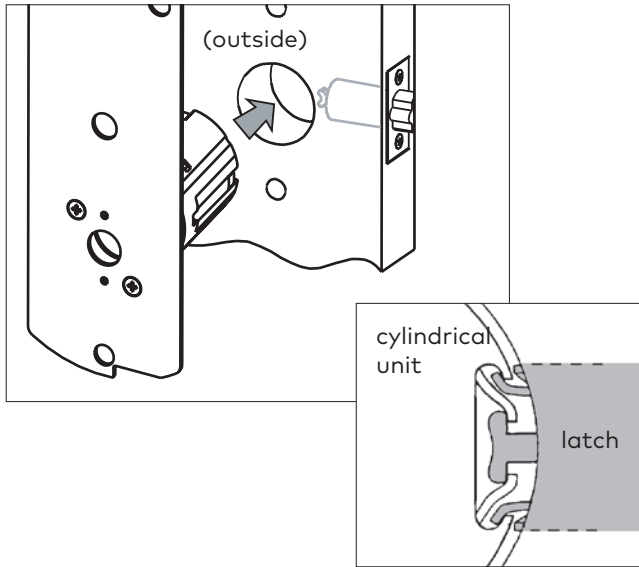

Put the thumbturn in the vertical position so that the arrow on the disc (E11) points UP.

If installing as a Storeroom function lock, lift the plate (E12) until the hole in the plate is aligned with the hole in the disc (E11), and fasten the disc and the plate securely together with the screw (E10) and lock washer (E9) provided. **The screw head MUST touch the surface of the disc for correct assembly.**

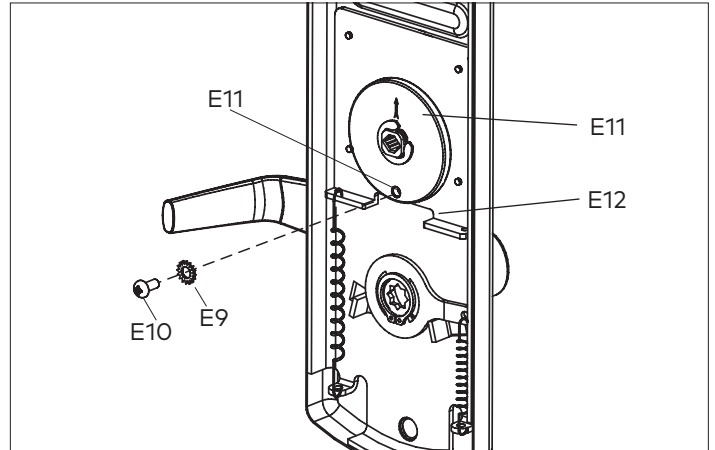

B.4 Inside Trim Assembly for Cylindrical

The inside trim assembly for cylindrical models includes parts assembled at the factory to control the motion of the thumbturn. An additional spring (E8) and locking screw (E10), packed separately, is added for storeroom applications (no privacy).

Do the following **BEFORE** placing the inside trim assembly on the door (page 10, step 7):

Install the additional tension spring (E8) between the plate (E12) and the post (E7), on the side opposite the lever handle spring installed in the last step.

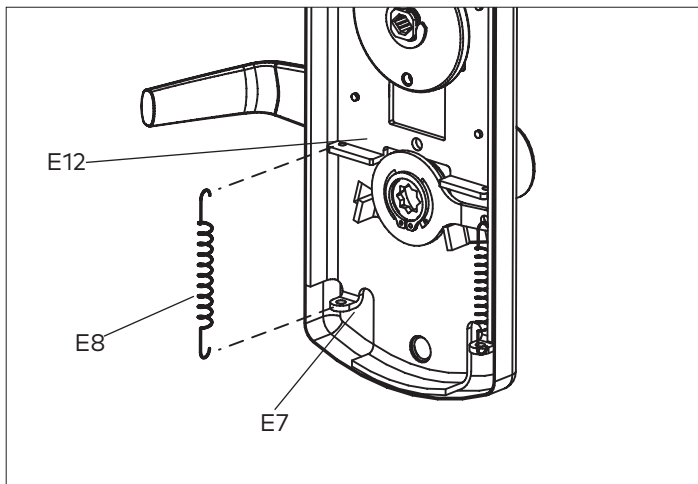

APPENDIX B Installing Cylindrical Models 2³/₈" & 2³/₄" Backset

B.5 Install Outside Housing and Trim Assembly for Cylindrical

1. Insert the slotted end of the square spindle (G) into the outside lever hub until it locks, at an angle of 45°. (The spindle can be removed by pulling on it, if oriented incorrectly.)

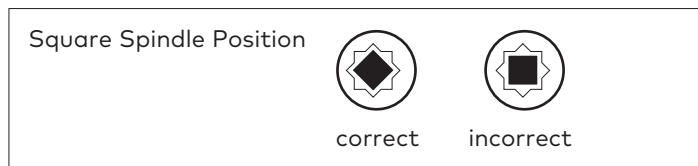

2. Insert the thumbturn spindle (F) in the upper hub of the outside housing. (It will clip in place.)

3. Assemble the gasket onto the outside housing. Assemble the cylindrical plate assembly onto the outside housing.

4. Place the outside housing on the door so that spindle (F) engages the thumbturn hole and spindle (G).

For models 79Z, 79Y, 79Q connect the cable (X) to the cable (W - not shown).

For model 79R leave the cable (X) in the door.

Make sure both cables are not pinched between the inside trim and outside lock on the face of the door. Engage hub of cylindrical unit. The cylindrical unit will engage the latch as shown in step 2 of B.3 (page 29).

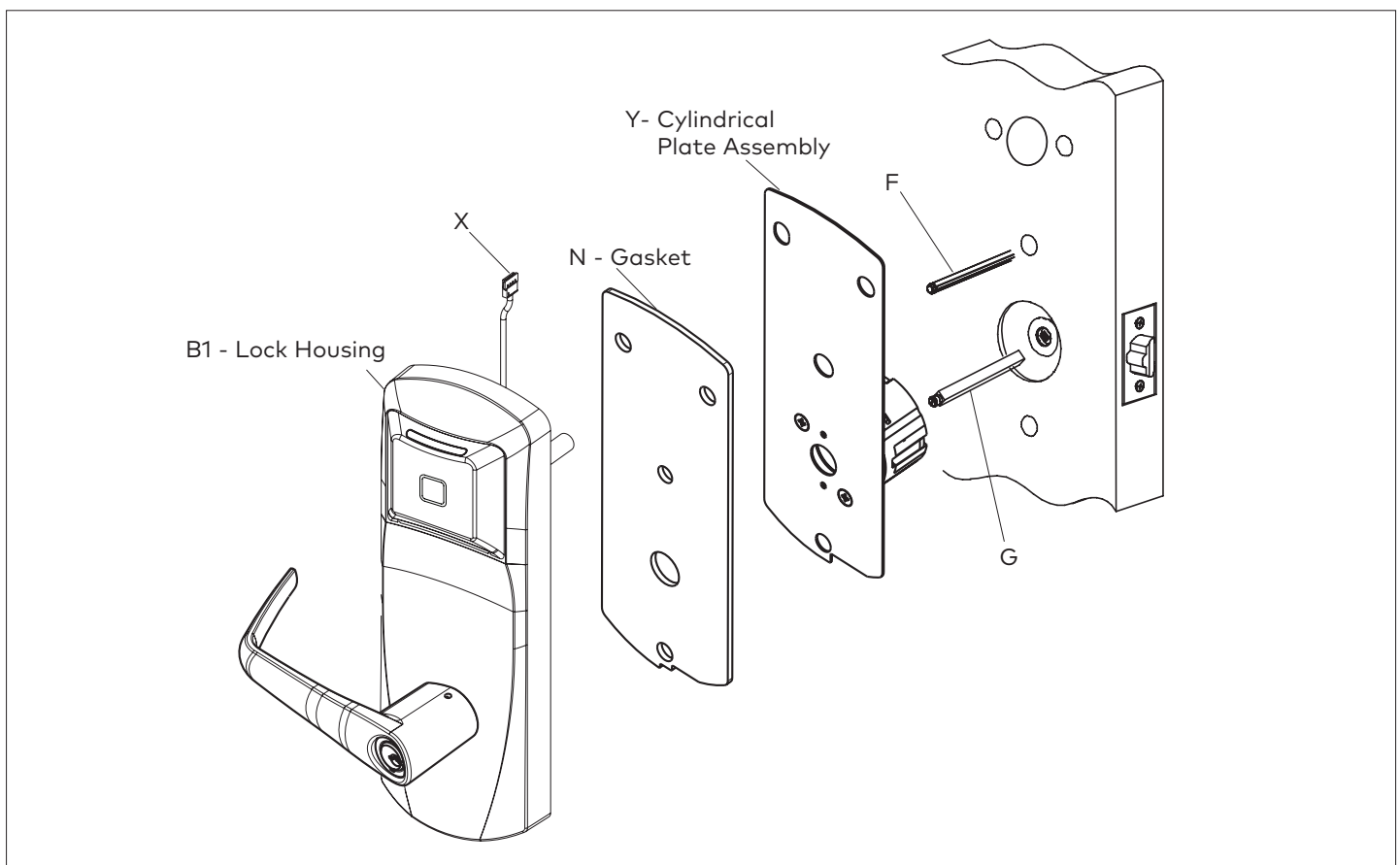

APPENDIX B Installing Cylindrical Models 2³/₈" & 2³/₄" Backset

5. Put the thumbturn (T) in a vertical position. Assemble the 3 spacers (S) on the door (for recent models only). Place the inside trim assembly on the door so that the upper and lower spindles (F) and (G) engage the thumbturn and the inside lever. Fasten to the outside housing using the three 1/8" hex drive mounting screws (I). Install the screws without tightening. Verify that the inside lever and thumbturn operates smoothly. If not, move the inside and outside housings slightly, then tighten the screws.

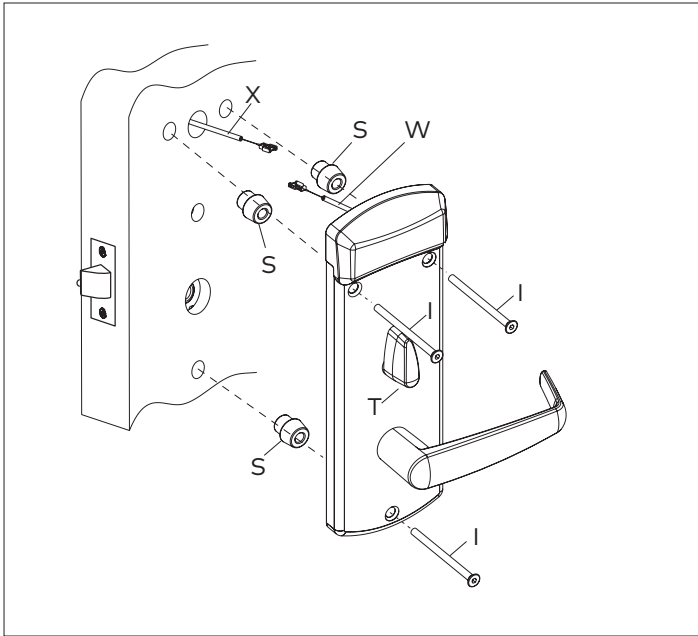

6. Three AA Alkaline batteries should already be installed in the battery holder (C). Insert the battery holder into the outside housing and secure it using the 6-32 x 5/16" (7.9mm) Torx drive screw (H).

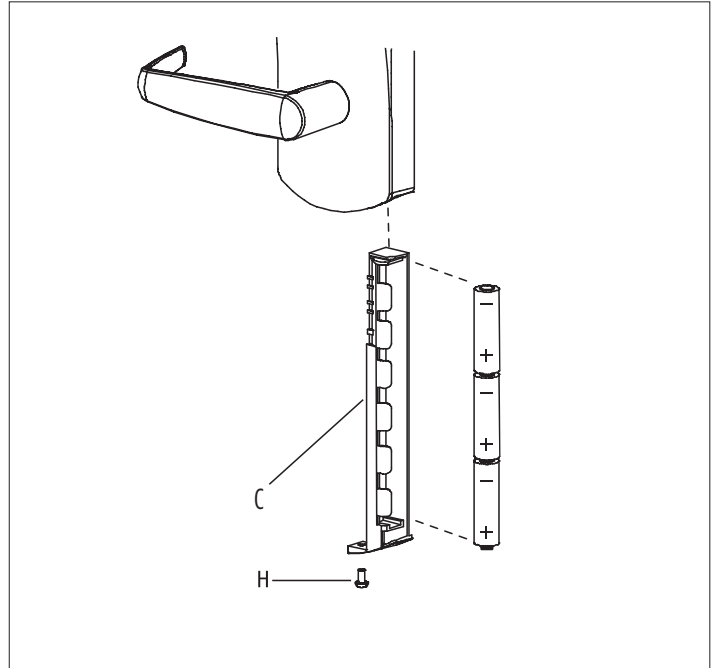

7. Testing the cylindrical lock: Follow all steps of page 16 but extension and retraction will be for latch only.

IMPORTANT

If the lock makes a continuous buzzing noise or the red LED lights continuously, reset the electronics by removing the battery holder for ten seconds, then reinsert it.

APPENDIX C Escape Return Model (79N)

C.1 ASM, ESM & ADB Inside trim assembly for 79N.

Note: 79N models are only for sale in Europe, where building codes allow. Use with mortise only.

Note: The inside trim assembly (E) for ASM/ESM and ADB on 79N models includes the part (E3) as shown below. The position of the stopper (E3) is very important.

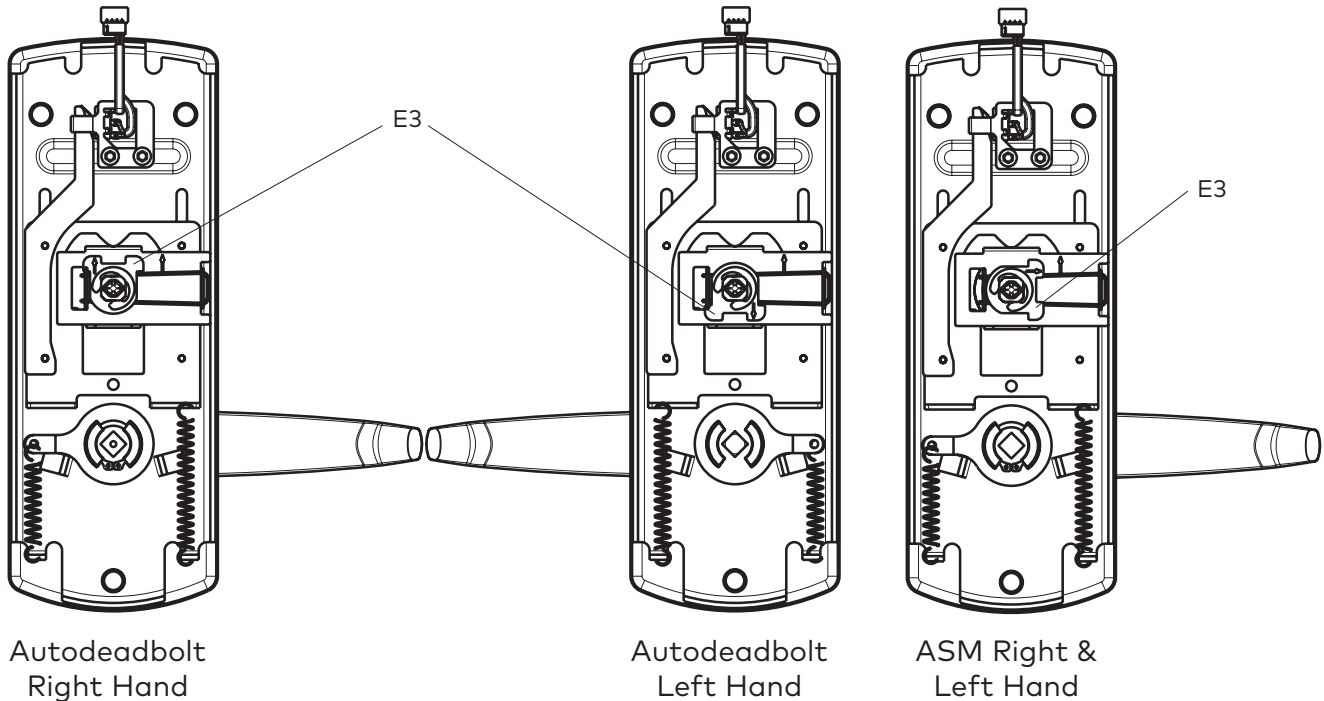

C.2 Installation of extension spring on inside trim.

1. On the inside trim assembly turn the lever to the correct horizontal rest position for the handing of the door. install the extension spring (L) between the handle (E6) and post (E7).

2. Install the additional tension spring (E8) between the plate (E12) and the post (E7), on the side opposite the lever handle spring installed in the last step.

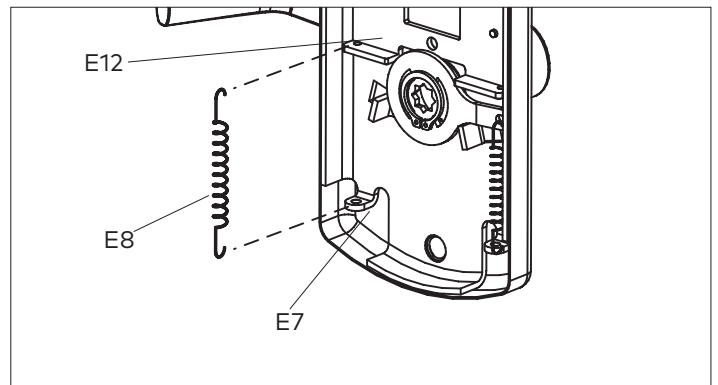
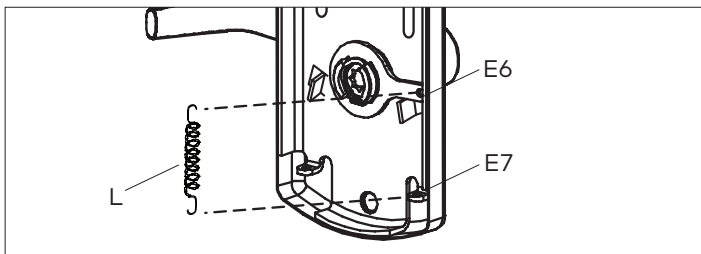

Installation Guide Lexicon

Letters for E MODEL

A	Outside lever E
B	Outside housing
C	Battery assembly
D	Mortise assembly
E	Inside trim assembly
F	Turn knob spindle
G	Square spindle
H	Torx head screw
I	3 Mounting screws
J	Machine screw 12-24x½ or 2 wood screws
K	Strike kit
L	Extension spring
M	Part required to control thumbturn motion
N	Outdoor gasket
O	Cylindrical latch and hardware
P	Face plate
Q	Latch deadlocking pin
R	Mortise 2 screws for bevel
S	3 Spacers
T	Turn knob inside trim
U	Cable ajar outside housing
V	Cable mortise ajar switch
W	Cable antenna inside trim
X	Cable antenna outside housing
Y	Cylindrical plate assembly

Letters for K MODEL

A1	Outside lever K
B1	Outside housing K
C1	Cylinder plug
D1	Cylinder
E1	Cylinder cap
E2	Instruction sheet attach lever on lock
F1	Inside drive hub
G1	Nylon washer
H1	Spring washer
I1	Drive tube
J1	Lever catch
K1	Override shaft
L1	Key
M1	Small flat screwdriver
N1	Small indent cross override shaft
O1	Set screw cylinder plug
P1	Allen Key 5/64"

Letters for inside trim

E3	Stopper
E4	Spring turn knob
E5	Turn knob plate
E6	Inside trim lever handle plate
E7	Inside plate tab to hook spring
E8	Pusher return spring
E9	Washer 6 star
E10	Screw 6-32
E11	Plate turn knob (disc)
E12	Pusher assy (plate)
E13	RFID Module
E14	Cable grommet
E15	Machine Screw # 6 x 5/16
E16	Flat washer # 6
E17	Retaining clip

Letters for mortise component

D2	Screw mortise
D3	Lock washer
D4	Dead bolt hub
D5	Dead bolt
D6	Auxiliary bolt
D7	Latch bolt
D8	Reversible tool
D9	Anti friction latch
D10	Latch bolt pusher
D11	ESM reversible pin
D12	Face Plate screw

Note for RT Plus series customers:

ISED non-interference disclaimer

This device contains license-exempt transmitter(s)/ receiver(s) that comply with Innovation, Science and Economic Development Canada's license-exempt RSS(s). Operation is subject to the following two conditions:

- 1) This device may not cause interference.
- 2) This device must accept any interference, including interference that may cause undesired operation of the device.

L'émetteur/récepteur exempt de licence contenu dans le présent appareil est conforme aux CNR d'Innovation, Sciences et Développement économique Canada applicables aux appareils radio exempts de licence. L'exploitation est autorisée aux deux conditions suivantes :

- 1) L'appareil ne doit pas produire de brouillage;
- 2) L'appareil doit accepter tout brouillage radioélectrique subi, même si le brouillage est susceptible d'en compromettre le fonctionnement.

RF Exposure statement

This equipment complies with ISED RSS-102 radiation exposure limits set forth for an uncontrolled environment. This equipment should be installed and operated with minimum distance 20 cm (7.6 inches) between the radiator and any part of your body. This transmitter must not be co-located or operating in conjunction with any other antenna or transmitter.

Pour se conformer aux exigences de conformité ISED RSS-102 RF exposition, une distance de séparation d'au moins 20 cm doit être maintenue entre l'antenne de cet appareil et toutes les personnes. Lanceurs ou ne peuvent pas coexister cette antenne ou capteurs avec d'autres.

FCC Compliance Statement

For class B

This equipment has been tested and found to comply with the limits for a **Class B** digital device, pursuant to part 15 of the FCC Rules. These limits are designed to provide reasonable protection against harmful interference in a residential installation. This equipment generates, uses, and can radiate radio frequency energy and, if not installed and used in accordance with the instructions, may cause harmful interference to radio communications. However, there is no guarantee that interference will not occur in a particular installation. If this equipment does cause harmful interference to radio or television reception, which can be determined by turning the equipment off and on, the user is encouraged to try to correct the interference by one or more of the following measures:

- Reorient or relocate the receiving antenna.
- Increase the separation between the equipment and receiver.
- Connect the equipment into an outlet on a circuit different from that to which the receiver is connected.
- Consult the dealer or an experienced radio/TV technician for help.

This device complies with Part 15 of the FCC Rules. Operation is subject to the following two conditions:

- 1) this device may not cause harmful interference, and
- 2) this device must accept any interference received, including interference that may cause undesired operation. Please note that changes or modifications not expressly approved by the party responsible for compliance could void the user's authority to operate the equipment.

RF Exposure Statement

This equipment complies with FCC radiation exposure limits set forth for an uncontrolled environment. This transmitter must not be co-located or operating in conjunction with any other antenna or transmitter. In order to avoid the possibility of exceeding the FCC radio frequency exposure limits, this equipment should be installed and operated with minimum distance 20 cm (7.8 inches) between the antenna and your body during normal operation. Users must follow the specific operating instructions for satisfying RF exposure compliance.

dormakaba USA Inc.
Customer services & support
1.800.999.6213 / + 1.248.837.3700

General information:
dormakaba.us
Online consumable orders:
www.saflokstore.com
To access all of our easy steps, please
visit our support website:
www.dormakabalodgingsupport.com